



جامعة قطر
QATAR UNIVERSITY

Qatar University Research Magazine

Issue no 13 - May 2020

QU Research and COVID-19 Pandemic

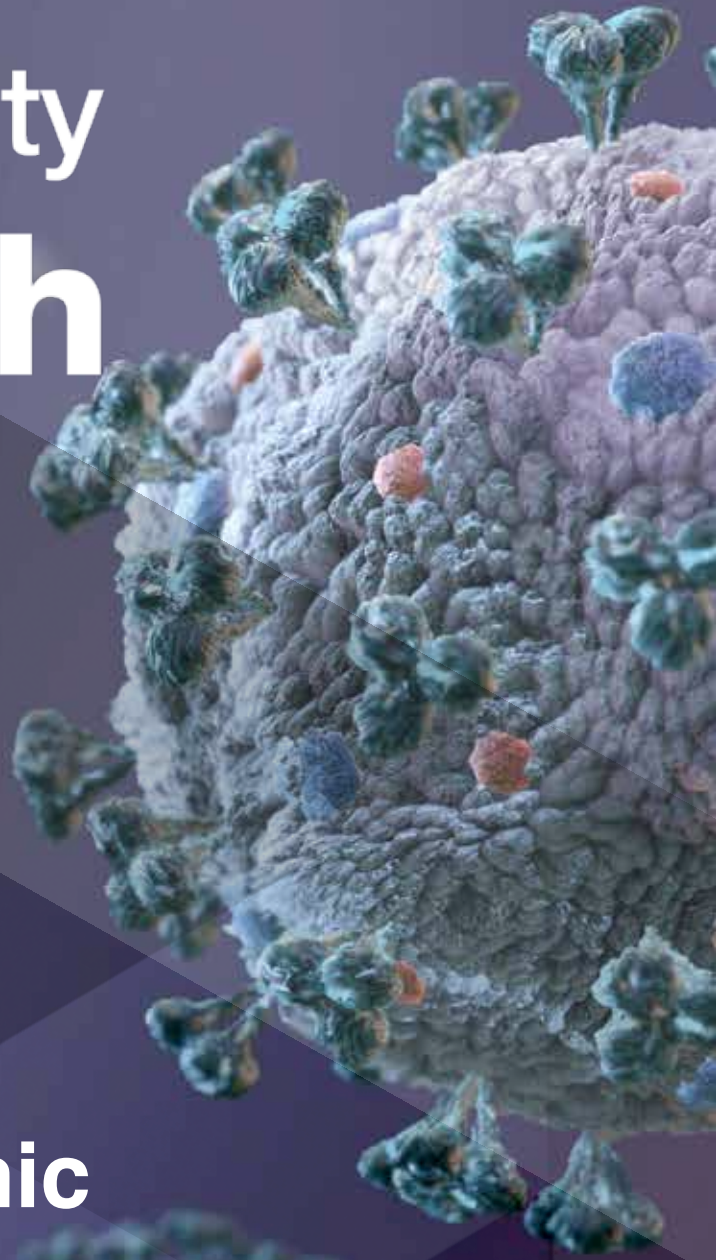

ENRICH YOUR LIFE WITH KNOWLEDGE
Follow our journey
Subscribe to Qatar University Research Magazine for Free



Scan the QR code with your mobile phone to
subscribe to our magazine, or visit us online at:

www.qu.edu.qa/research/publications/issues

Research and Innovation address Emergency Events A Workable Model in the COVID-19 Pandemic

Dear Readers,

This Issue of Qatar University Research Magazine is published under exceptional conditions brought by Coronavirus COVID-19, which is a widespread global pandemic that can only be countered by scientific research. Therefore, we have exerted every effort to meet research requirements and drive it towards further progress and innovation. This pandemic has proved the priority of supporting research and studies that address emergency events and protect human life and health, and contribute to disseminating knowledge and achieving community sustainable economic and social development.

Coronavirus has raised red flags. Researchers and scientists have taken the necessary actions to confront it at all levels. In response to this challenge, QU's Research and Graduate Studies Sector has announced an emergency scholarship, which constitutes part of the international research efforts exerted to deal with COVID-19. This rapid response initiative supports scientific research and contributes to raising awareness and securing adequate protection, as well as highlighting the role the University plays in addressing and facing global concerns originating from this virus.

Colleges and research centers, including the Biomedical Research Center, which is licensed and qualified to conduct virology research, go all out to study the reality of this virus and prevent it from spreading. Researchers and specialists hold meetings through e-platforms in the form of a series of seminars and conferences with a view to discuss the University's activities and research

initiatives developed to confront the Coronavirus pandemic. The "COVID-19: Challenges and Attitudes" Conference and "Post-Coronavirus Knowledge-based Economy" Seminar were held in order to improve the great efforts exerted by the State of Qatar in this area. Moreover, the Social and Economic Survey Research Institute has conducted surveys to receive feedback from Qatari citizens and expatriates regarding Coronavirus to measure the extent of their awareness of COVID-19 seriousness and inform the respective authorities to consider those when setting up precautionary plans.

We have published this Issue under exceptional conditions and wanted the cover to reflect the current research challenges. In this Issue, the College of Law sheds light on laws and regulations related to Bitcoin currencies, and the implementation of green buildings project in the State of Qatar. The Health Cluster has shared with us the most salient research findings and achievements, inclusive of the first research paper of the College of Dental Medicine. Also, a new classification method to predict therapeutic responses to new drugs from the College of Medicine, a new discovery of the most common homocysteine syndrome in Qatar, and a cardiac rehabilitation program from the College of Health Sciences.

In this Issue, Qatar University researchers enshrine the sustainability culture, as the Qatar Transportation and Traffic Safety Center participates in creating a culture of sustainable transport. The Center for Advanced Materials



presents smart solutions for the sustainability of seawater desalination. The College of Pharmacy provides a quick overview of the sustainability of the drug policy.

College of Sharia and Islamic Studies and College of Business and Economics also shared the achievements of their students with us. In addition, we bring out how to activate the mechanism of joint supervision and dual degrees with the Universities of Alberta and McGill for Graduate Students in Canada, not to mention the opening of the Aquatic Research Center, an expansion of the Research and Graduate Studies Sector.

In this case, it is a great pleasure to congratulate the inventors for the eminent success that QU realized at the 12th International Invention Fair of the Middle East, held in Kuwait, last February.

Finally, in this Issue, you will come across information, reports, and several dialogues concluded by the active participation of many Qatar University constituents and sectors.

Best wishes of success and safety for all.

Prof. Mariam Al-Maadeed
Vice President for Research
and Graduate Studies
Qatar University



Qatar University Research Magazine is a publication issued by the Research & Graduate Studies Sector at Qatar University

Issue no 13, May 2020

General Supervision
Prof. Mariam Al-Maadeed

Editor-in-Chief
Amani Ahmad Othman

Editors
Noora Ahmed Al-Fardi

Design
Gasan Al bateeri

Text Review
Prof. Sultan Muhesen
Atef Shafiq Mohammed

Revision & Proofreading
Qatar University Press

News	4
QU Shines at the 12 th IIFME in Kuwait; Wins Four Medals	4
Implementing Joint Supervision Scheme and Degrees for Graduate Students at Qatar University (QU)	8
Qatar University's Partnership with the Ministry of Municipality and Environment: The Opening of the Aquatic Research Center	9
Published by Qatar University Press: A Book "Television News Report" by Department of Mass Communication of the College of Arts and Sciences ...	11
Research Achievements	12
A New Discovery by a Qatar University Scientific Team for the Functional Structure of the Most Prevalent Genetic Mutation in Qatar	12
Environment and Health Interaction: A Multidisciplinary Approach Towards Understanding the Impact of Cadmium on Cardiovascular System	14
Predicting Clinical Responses to New Potential Drugs: A New Classification Method	16
Discovery of the Genetic Predisposition to Super Athletic Performance ...	18
Environmentally Powered WSN for Air Quality Monitoring	20
Students Achievements	22
A Comparative Jurisprudential (Fiqh) Study: Women's Rights and Qatar's Family Law	22
Mobile Government Services and Resident Satisfaction: Evaluation of Kahramaa Mobile Services in Qatar	24
Interviews	27
Interview with a Student: Mashael Al-Badr PhD Student	27
Interview with Researcher: Prof. Ayman Saleh - College of Sharia and Islamic Studies	28
A Story of a Center: Gulf Studies Center, College of Arts and Sciences- Qatar University	30
Research Issues	34
Achieving Green Building in Qatar Through Legal and Fiscal Tools	34
Rotavirus Epidemiology and Vaccine Effectiveness in Qatar: Ongoing Challenges	37
Environmental Restoration Solutions: The Mushroom Forest Artificial Reef	38
Sustainability Pharmaceutical Policy for Qatar: A Quick Insight	41
Resin Bonded Bridges in Patients with Hypodontia: Clinical Performance Over a 7-year Observation Period	44

Research Articles

46

Our Role towards Creating a Sustainable Mobility Culture in Qatar: The Case for Electric Cars	46
Control of Heart Diseases: Cardiac Rehabilitation Program	48
Water Control in Oil and Gas Wells: Novel Polymeric Gels	50
Smart Solutions for Sustainable Seawater Desalination: Nanoscience-based Electrochemical Technologies	52

Reports

55

QU College of Law Organizes Annual Conference 2020 on the Topic 'Law and Media'	55
Qatar University's Graduate Studies Office Welcomes Students on the Orientation Day for Spring 2020 Semester	57
tad Boot Camp 2020	58
Center for Advanced Materials Organizes Seminar on New High-Performance Poles for Water Desalination Using Electricity: Emerging Water Treatment Technology	60
QU Celebrates International Day for Women and Girls in Science 2020	62
"Towards a New Gulf Security System: Abandoning the Zero-Sum Approaches" Conference at Qatar University	65
International Conference: Islamic Economics and the Question of Development: Critical and Innovative Analyses	68
"Philosophy, as a Bridge Among Cultures" The Second International Symposium of the Philosophy Program, Department of Humanities, College of Arts and Sciences	70
Ninth Awareness Workshop for Undergraduate Students on Agreements on Weapons of Mass Destruction	72
Qatar University Press Participation in the 30 th Doha International Book Fair and the 5 th Istanbul Fellowship Program	73

Issue File

76

On the Emerging Coronavirus (COVID-19), which invaded the Entire World and pushed it towards a Global Red Alert, we Spoke to Dr. Asmaa Al Thani	77
How could artificial intelligence aid in the fight against coronavirus? Interview with Dr. Hadi Yassine Manager of Research Projects at the Biomedical Research Center	79
(SESRI) - (QU) Conducts Survey on Coronavirus (COVID-19)	82
COVID19 Serology Screening ELISA Test and Potential Vaccine Candidate Development	86
e-Health at Qatar University and COVID19	89
Qatar University continues academic activities despite COVID-19 challenges	92
Qatar University Emergency Response Grant (ERG)	94

The Research and Graduate Studies Office acknowledges the contributions made in support of publishing this issue. Editorial contributions are also welcomed on the following email: vrpgs.eco@qu.edu.qa

All rights reserved. No part of this magazine may be reproduced, stored in a retrieval system, or transmitted in any form or by any means without prior written permission from the Research & Graduate Studies Office at Qatar University.

All statements and opinions herein reflect the view points of the authors only and do not reflect the opinion of the Research & Graduate Studies Office at Qatar University.



QU Shines at the 12th IIFME in Kuwait; Wins Four Medals

Qatar University (QU) strives to realize its objectives related to distinction in scientific research and adopting leading and innovative approaches that correspond to the needs and future aspirations of the community. Four inventors from QU have reflected this distinction when they each won medals: a gold one, two silvers and a bronze medal at the 12th IIFME - International Invention Fair of the Middle East, held in the State of Kuwait on 16-19 February 2020.

QU is extremely proud of such a great achievement and highly appreciates the efforts made by the inventors for the sake of scientific progress and for honorably representing QU in international conventions and forums, asserting the University's status as Qatar's leading center of excellence with its highly specialized human resource.

The First Prize-Winning Invention with Honors (Gold)



Innovative Marine Clutch



Dr. Ibrahim Al-Maslamani

The invention: Marine Clutch.

Inventor's name: Dr. Ibrahim Al-Maslamani, Advisor at the Office of Vice President for Research and Graduate Studies at Qatar University.

About the Invention:

This invention can generally act as an ancillary to fishing apparatus. More specifically, it is a fishing cage retrieval device, designed to reduce or eliminate environmental damage to the seafloor. The device includes two sled-type structures, spaced apart, for guidance along the seafloor, while minimizing the damage to it.



The Second Prize-Winning Invention (Silver)

The invention: Measurement Method for detecting the defective antenna elements in massive MIMO Antenna Arrays.

Inventor's name: Dr. Ridha Hamila, Professor in Electrical Engineering at Qatar University.

About the Invention:

This invention relates to multiple-input and multiple-output (MIMO) antenna arrays that will be adopted for 5G Network. It provides a

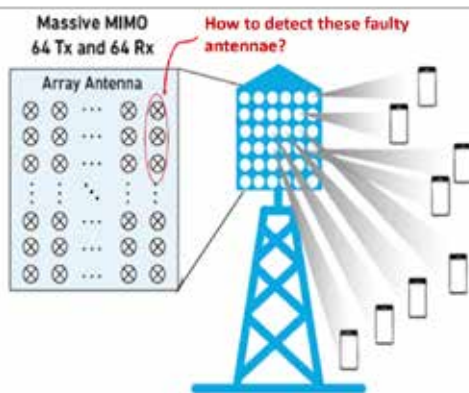

Figure shows faulty antenna elements in a massive MIMO antenna arrays

method for detecting antenna elements in MIMO antenna arrays. The method is based on compressive sensing techniques and coherence analysis of the measurement matrix, namely, the average coherence and worst-case coherence metrics, which are jointly used to determine the best method to collect the measurements.



Dr. Ridha Hamila



The Third Prize-Winning Invention (Silver)



LED turned ON



Mohammad Meraj

The invention: linear regulated dimmable light emitting iodide (LED) driver for a direct current (DC) grid connected LED string.

Inventor's name: Mohammad Meraj, PhD student in electrical engineering at Qatar University is a representative of his research team led by Dr. Atif Iqbal, and his colleagues, Syed Rahman and Lazhar ben-Brahim.

About the Invention:

This invention relates to power supplies. It is a linear regulated dimmable light emitting iodide (LED) driver for a direct current (DC) grid connected LED string. It also provides a linear regulated dimmable LED driver that avoids the use of inductors and other large and expensive electronic components, while avoiding EMI and other issues associated with pulse-width modulation (PWM) dimmers.



The Fourth Prize-Winning Invention (Bronze)



Two prototypes of Electronic Chest Drain Monitor (ECDM)



Dr. Nasser Al-Emadi

The invention: Electronic Chest Drain Monitor (ECDM)

Inventor's name: Dr. Nasser Al-Emadi, Head of the Department of Electrical Engineering at Qatar University, on behalf of the late, Dr. Moheiddine Benammar.

About the Invention:

The invention relates to medical devices and systems and provides a method of and apparatus for monitoring the volume and rate of blood and air draining from a patient that provides an objective, computer-controlled, real-time, air drainage data sensing/display/digital recording system, that facilitates and enables remote monitoring of a patient.





The award of the GCC Patent Office to promote innovation and invention

The winning inventors were honored by HE Minister of Culture and Sports Mr. Salah bin Ghanem Al-Ali, for their merit and honorable representation of the State of Qatar. Winners and their representatives were cordially invited by QU President Dr. Hassan bin Rashid Al-Derham to be honored at the University. Dr. Ibrahim Al-Maslamani was honored for winning a gold medal with honors in addition



Dr. Ibrahim Al-Maslamani winner of first place of the award of the GCC Patent Office to promote innovation and invention

for bagging the first place at the Gulf Cooperation Council (GCC) Patent Office Awards and for supporting innovation and invention, granted to inventors from the GCC States. Similarly, Dr. Ridha Hamila and student Mohammad Meraj were honored

for winning silver medals. Finally, Dr. Nasser Al-Emadi was honored on behalf of the late Dr. Moheiddine Benammar for winning a bronze medal. The late inventor's family was invited to attend the honoring ceremony by Dr. Hassan Al-Derham.



President of Qatar University Dr. Hassan Al-Derham honoring the inventors

Implementing Joint Supervision Scheme and Degrees for Graduate Students at Qatar University (QU)



From right to left: Prof. Feras Alali, Prof. Neal Davies (Dean of Faculty of Pharmacy, University of Alberta), Prof. Ayman El-Kadi (Associate Dean of Research and Graduate Studies, Faculty of Pharmacy, University of Alberta), Prof. Ahmed Elzatahry and Prof. Ala-Eddin Al-Moustafa.

Qatar University (QU) offers a joint research Doctorate in Health Sciences at the College of Medicine, College of Health Sciences and College of Pharmacy. The university cooperates with a number of medical institutions and organizations within Qatar, such as Hamad Medical Corporation (HMC), being the clinical institution of research application, Ministry of Public Health (MOPH) and Primary Health Care Corporation (PHCC). Additionally, it has concluded cooperation agreements with Sidra Medical and Research Center, Qatar Foundation for Education (QF) and Aspetar Hospital. Similarly, QU extends its services through cooperation with other institutions outside Qatar for the purpose of enriching the medical research community and providing an educational environment, which promotes student engagement in their studies as well as involvement in extra-curricular experiences and experiments. In light of the aforementioned, and for developing the Graduate Programs, a delegation from QU visited the University of Alberta and McGill University in Canada from 24–28 November, 2019, to initiate steps for the

implementation of the concluded agreements with these two universities as well as to propose Joint Supervision Programs, which will enable the students to qualify for receiving joint degrees from the two universities.

The QU delegation was headed by Dr. Ahmed Elzatahry, Dean of Graduate Studies, Dr. Feras Alali, Director of Research and Graduate Studies at Qatar University's Health Cluster, and Dr. Ala-Eddin Al Moustafa, Professor of Cancer Science at the College of Medicine. The delegation discussed the implementation of agreements related to the Joint Supervision and Joint Degrees initiative for graduate students, specifically the research doctorate students at Qatar University's Health Cluster, concerning Medicine, Pharmacy and Health Sciences.

QU, University of Alberta and McGill University have agreed upon the following:
Appoint a principal supervisor from each university for every student, in relation to the joint supervision scheme.

Scheme of conducting research for Doctoral Theses.

Scheme of determining and grading curriculums.

Scheme of applying for joint research projects to support students' theses.

In light of what has been agreed upon, these partnerships enable students to join universities and make use of the possibilities offered by the partner university and go through different experiences related to the field of their studies.

It is expected that, the joint supervision and joint degrees scheme will contribute to enhancing the quality of doctoral research outputs, as well as promoting efforts for resolving issues related to the community. The Office of Graduate Studies is keen to explore new opportunities and innovative ways to improve services and support provided for students, in addition to its commitment of facilitating research activities and interests of researchers and distinguished students.

It is worth noting that, the aforementioned agreements are concluded for the purpose of realizing one of the most significant strategic objectives of the sector of research and graduate studies within QU 's strategic plan, which is building diverse research partnerships with prestigious global universities in various fields, in addition to building national competencies and arming them with distinguished scientific and academic experiences. Also, cooperating with community and industry stakeholders to develop talents and encourage innovation and entrepreneurship within graduate students in order to support sustainability and knowledge economy.

Qatar University's Partnership with the Ministry of Municipality and Environment: The Opening of the Aquatic Research Center

Qatar University (QU) continues to expand its research projects, fostering its relations with ministries and corporations within and outside the State of Qatar, in order to develop the Qatari economy and sustain the sources of income on which the country relies upon. QU supports research areas that are consistent with the national research priorities of the country and thereby meeting the needs of society.

The Aquatic Research Center in Ras Al-Matbakh, inaugurated on January 25, 2020, is one of the largest projects in the national strategy programs, focused on the development of the fisheries sector, fish farming and marine environment research. In addition to development and economic objectives, Qatar University's partnership with the Ministry of Municipality and Environment (MME) is aimed at establishing an integrated project, both from the research and development, and production aspects, where the center will be equipped with the latest laboratories and equipment to serve this project. The implementation of the project at the Aquatic Research Center is aimed at sufficiently securing food for the population and taking the country towards achieving self-sufficiency and food security. The center will also enable the country to increase the local fish production and help



HE the Former Prime Minister together with (QU) and (MME) researchers and invitees in the opening ceremony

in achieving food security by providing small amounts of fish that can be used by the private sector to establish aquaculture farms in the country.

The center supports various research institutions in the State of Qatar, by establishing a place specializing in scientific studies and research, related to marine science and fish farming. In addition, experiments are conducted on specific local marine species that are economically viable cultures in Qatar. The experiments use modern fish farming systems that are highly efficient and most suitable for use in the environmental and climatic conditions of the Arabian Gulf region. Training of national cadres and capacity building in the field of fish farming is one of



HE Former Prime Minister Sheikh Abdullah bin Nasser opening the Center

the most important objectives to be achieved by the center.

The Aquatic Research Center is based on the cultivation of economically viable species that have a distinct market demand in Qatar, especially the species of black finned sea-bream, marbled spinefoot, silver sea-bream and local shrimp.

The building of the Aquatic Research Center is divided into two parts:

The Administrative Building and Scientific Laboratories: This part of the center consists of 28 administrative offices and two meeting rooms, in addition to 7 specialized scientific laboratories, including laboratories of physical and chemical measurements. It also includes a laboratory for the study of fish parasites and bacteria, and analysis of fish feed ingredients and others. The focus of this facility will be to conduct marine environmental research and experiments.

Fish farming: This part of the center consists of a fish hatchery, a nursery unit, a fish-fattening unit, a phytoplankton and zooplankton production unit, a quarantine unit, and water laboratories for fish farming experiments. The focus of this facility would be the application

of modern fish-farming systems and supporting sufficient fishery stock in the country.

The expected production capacity of the Aquatic Research Center:

The Aquatic Research Center expects that the annual production capacity of fish in the fish hatchery unit may reach about 2 million larvae per year during four hatching seasons, and the center's production may reach 10 million larvae per year at the production stage. In the fish nursery unit, it is expected to produce 2 million fingerlings weighing 2 grams annually. As for the first fattening unit, its production is expected to reach 1.5 million fingerlings

weighing 10 grams per year, and the final fattening unit will reach the production level of 8 tons of fish with a weight of 250 grams annually. With regard to the annual production capacity of shrimp, the shrimp larvae culture unit is expected to reach 2 million larvae per year during four hatching seasons at the trial stage and up to 10 million larvae at the production stage. The production of shrimp incubation unit is expected to be 1.6 million young shrimps, weighing 2 grams annually, and the final fattening unit that contains earthen ponds may reach 6 tons of shrimps with weight of 25 grams annually.

It is worth mentioning that the establishment of the Aquatic Research Center comes within the framework of Qatar National Vision 2030 and the state's plans to promote fisheries and aquaculture. Marine conservation of natural resources, conservation of endangered species where all conditions are provided for their development, will also be of significance to this collaboration. Qatar University is one of the leading institutions in the country, taking forward the research for preservation of marine wealth, thereby preserving the national wealth of the country.



HE the Former Prime Minister touring the Center's departments

Published by Qatar University Press:
A Book “Television News Report”
 by Department of Mass
 Communication of the College
 of Arts and Sciences



“Television News Report”



Dr. Fayeza Shaheen, Assistant Professor in the Department of Mass Communication, College of Arts and Sciences - Qatar University

A Book was published by Qatar University Press entitled, “Television news report: types, importance, components, language and standards” by the author, Dr. Fayeza Shaheen, Assistant Professor in the Department of Mass Communication, College of Arts and Sciences - Qatar University. Qatar University Press organized a book signing ceremony at the Doha International Book Fair during January this year, which was attended by a large group of professors, students and audience.

The 550 page book mainly relies on mainly relies on German scientific references. The book consists of ten different topics that talk about the elements of the partial news report such as text, image and sound, and its

structural elements from titles, information introduction, audio excerpts, etc., and its technical elements of photography, lighting and drawing up the appropriate image plan. The book also addresses the dilemmas of understanding news report, and about the relationship of its media reality with the real reality, as well as the methods of linking the news report and other forms of news presentation in the newsletter from simple news and news interviews.

The book contains a scientific comparison between “the objective news report” and “the compositional report”, which is used in the compositional language as an expression tool, so the writer extracted from this comparison fourteen differences, all of which were in favor of

the objective news report. At the end of the book, eighteen innovative artistic templates help in preparing news report in its various forms and topics. This book is unique because of the fact that it contains about 90 news reports that are full-text and images, either in whole or in part, borrowed from different television stations, and Al-Jazeera News channel stood for the lion’s share of them.

The main objective of this book is to transform Al-Jazeera Media School into an academic school based on solid scientific foundations, and to develop an academic course bearing the name of Qatar University, which is suitable to be a course for media students in all Arab universities and institutes that teach Media.



A New Discovery by a Qatar University Scientific Team for the Functional Structure of the Most Prevalent Genetic Mutation in Qatar

Dr. Gheyath Khaled Nasrallah
Associate Professor of
Biomedical Sciences, College
of Health Sciences - Qatar
University

“Homocystinuria” is a rare inborn error-inherited metabolic disorder that results from deficiency of an enzyme called cystathionine beta-synthase (CBS). This enzyme is important for degradation of the excess amount of a dietary essential amino acid found in dietary protein, known as methionine. In normal people, methionine is degraded to intermediate toxic metabolites known as homocysteine. The body then gets rid of the excess amount of homocysteine by the CBS enzyme, which further breaks down homocysteine to a non-toxic amino acid known as cysteine. However, for a person with homocystinuria, this process cannot complete due to defect in the CBS enzyme activity. Consequently, this leads to a huge accumulation of the homocysteine

in blood and urine. Accumulation of homocysteine in the blood causes major complications including cognitive and physical developmental delays and can lead to severe complications such as mental retardation, physical deformation and death. Patients with homocystinuria require daily medication, a special diet and ongoing treatment from a specialist physician and therapeutic nutritionist who may recommend a special diet and supplements. The most common form of the disease is thought to affect around 1 in 200,000 people worldwide. However, Qatar has one of the world’s highest incidence rates. This high frequency is primarily attributed to a single founder Qatari mutation, p.R336C (c.1006C>T) in the CBS gene, a missense mutation resulting from replacing arginine (R or Arg) with cysteine (C or Cys), causing a severe vitamin B6 non-responsive phenotype (El-Said et al., 2006). One of the most severe homocystinuria phenotypes is the one found in Qatar due to the p.R336C mutation, which has been shown to be non-responsive to pharmaceutical therapeutic approaches. Dr. Gheyath Khalid Nasrallah from the Department of Biomedical Sciences, College of Health Sciences, and Biomedical Research Center in Qatar

University (QU) is leading a national priority project aiming to characterize the structure-function relationship of the p.R336C mutation and CBS enzyme activity and to find a potential therapeutic agent that can correct the defect in the CBS enzyme activity caused by the p.R336C-CBS mutation. To achieve this goal Dr. Nasrallah's team employed three functional models: In silico (computational model), Δ CBS yeast, CRISPR/Cas9 p.R336C knock-in HEK293T kidney and HepG2 liver cell lines, and the mouse model. This project was conducted in collaboration with a group of scientists from Sidra Medical and Research Center, Imperial College London, Hamad Medical Corporation and Fox Chase Cancer Center, Philadelphia, USA. The research conducted was recently published in the journal "Human Mutation" under the title "In silico and in vivo models for Qatari-specific classical homocystinuria as basis for development of novel therapies." Using in silico computational protein modeling and molecular dynamics simulations, the team was able to solve the structure and the position p.R336C in the CBS protein, suggesting that the p.R336C mutation induces severe conformational changes that leads to incorrect folding and assembly of this protein to form functional tetramer. These changes might lead to early degradation of the CBS enzyme making it inactive. Indeed, this assumption was confirmed by four models: the yeast, the human HEK293T kidney HepG2 liver cells and the mouse model carrying the exact same p.R336C mutation. The team showed that the p.R336C mutation had a more profound effect not only on the amount of CBS enzyme made by the cells, but also the structural stability and activity, where the proper assembly and formation of a functional tetrameric form of CBS was missing or degraded. Recent studies suggest that chemical chaperon (low molecular weight molecules) therapies are an emerging novel concept for protein-misfolding diseases. In

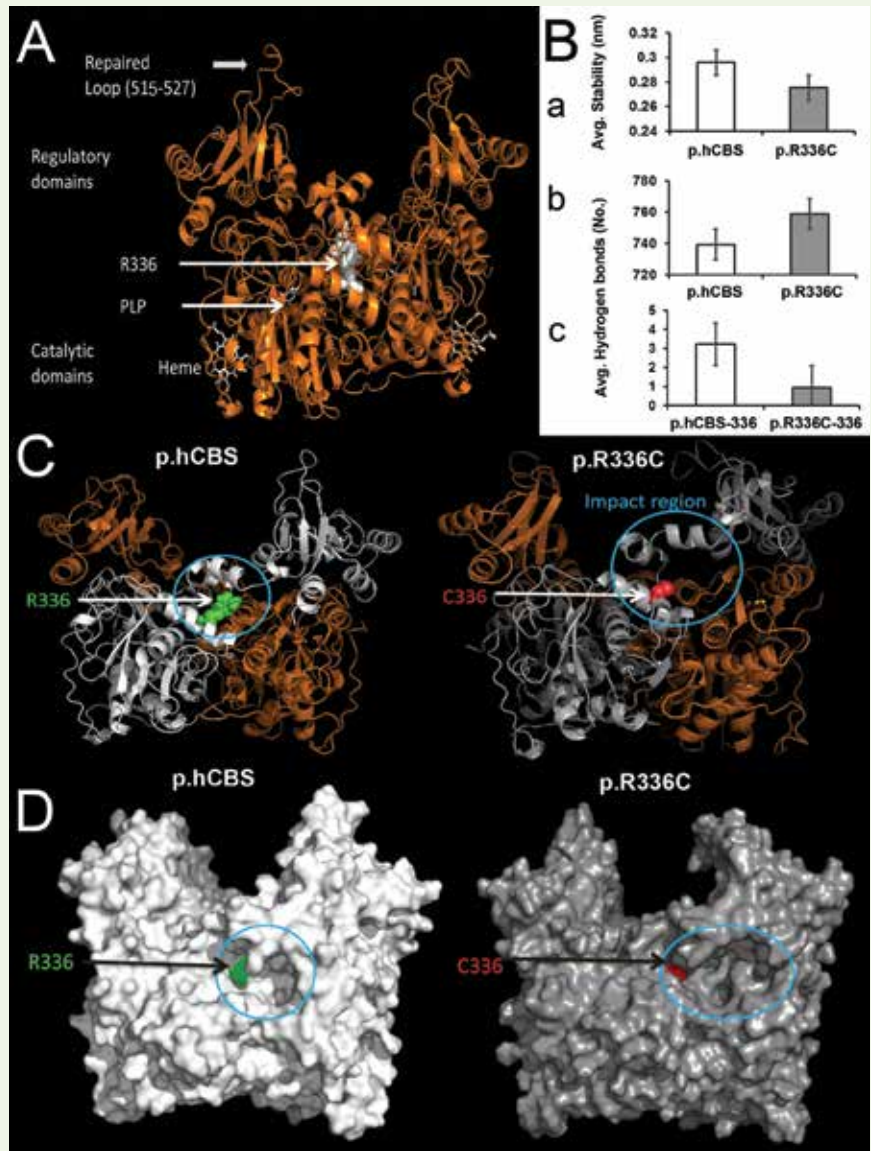

A Silico model for the human CBS protein and the R336C mutant

this study, the chemical chaperone approach was applied in tissue cell culture models by using many different chemical chaperons. With the exception of one promising compound called betaine, many other chemical chaperones failed to correct the misfolding and conformation defect in the CBS enzyme caused by the p.R336C CBS. Interestingly, betaine restored the stability and tetrameric conformation of CBS, but not its activity. The team suggested that in combination with other potential chemical agents, betaine could be a promising therapeutic target for the p.R336C CBS Qatari Mutation. This article was published in scientific and

global journals, which are the Journal of Inherited Metabolic Disease: Analysis of the Qatari R336C cystathionine β -synthase protein in mice and Journal of Inherited Metabolic Disease: Natural history, with clinical, biochemical, and molecular characterization of classical homocystinuria in the Qatari population. For more details read the report "A Scientist From Qu And His Team Characterized The Structure-Function Relationship Of The Cbs Enzyme Activity With The P.R336c Qatari Mutation Causing The Metabolic Disorder "Homocystinuria", at: shorturl.at/krs46.

Environment and Health Interaction: A Multidisciplinary Approach Towards Understanding the Impact of Cadmium on Cardiovascular System

**Dr. Hamda Abdulla Al-Naemi, Director of Laboratory Animal Research Center (LARC)
– Qatar University**

Human interactions with their natural and man-made environment are diverse, strong and continuous. Moreover, these interactions potentially have a profound impact on human health and wellbeing. The quality of what we inhale, or consume has an influence on our vital biological systems and eventually on our overall health. Ever increasing human industrial and urbanization activities contribute to detrimental environmental pollutions of various kinds, and among them heavy metals play a major role in manifesting environmental toxicity on living organisms. Heavy metals find their way into the soil, air, water and food chains where they exert potential risk to human health. Consumption of food contaminated with heavy metals leads to various bio-toxic effects that have serious consequences on health. Cadmium is one of the naturally occurring heavy metals used in Nickel-Cadmium battery industry, pigment production, synthesizing chemical stabilizers, metallic coatings, manufacturing Phosphate fertilizers and alloys. Cadmium has a potential of high rate of transfer from soil, or water to plants and animals to reach human food chain. Given the non-



State of the art technology used in Animal Lab that provides precise control for the experiment condition

dietary source of Cadmium such as industrial smokes and smoking habits on individual basis it is hard to calculate the daily consumption of cadmium. In addition, as per the chemical nature, Cadmium is a bio-accumulative metal that can stay in organs and tissues for more than two decades. Scientific results have shown that cadmium accumulates in various organs such as liver, kidney, lungs, heart, skeletal muscle, bones and brain. Recent research findings reiterate that Cadmium has been listed as an independent risk factor for

cardiovascular diseases. Dr. Hamda Al Naemi, the Director of Laboratory Animal Research Center (LARC) has a fascinating research interest of understanding the environmental impact on human health. Dr. Al Naemi took several academic research training and scholarly endeavors to understand the intriguing mechanism driving the toxicity of Cadmium as one of the environmental pollutants that impacts human health. Capitalizing on her educational background skills and training

received from both science and medical schools from overseas Dr. Al Naemi established a research group to study Cadmium toxicity in LARC (specific Pathogen Free SPF Facility) at Qatar University. The research led by her group adopted a multidisciplinary approach, using toxicology, physiology, molecular biology, epidemiology and analytical chemistry to investigate the impact of selected environmental risk factors on human health. She has successfully trained a team of researchers and students focused on research objectives using several research techniques and multiple bioassays to investigate the impact of chronic (long-term) exposure of Cadmium on the cardiovascular system. Using the state-of-the art Laboratory Animal Research Center (LARC) at Qatar University, Dr. Al Naemi and her group could embark an array of in-vivo studies to test the Cadmium toxicity at the cellular level in rodent models. Building human resources by developing trained researchers and enabling cutting edge analytical capability through infrastructure building are of great value for enriching the expertise and making significant contribution to the knowledge of environmental pollution.

Current research efforts are focused on evaluating the effect of low (dose) quantity consumption of Cadmium for a long period as a chronic setting. The research team is working on establishing several research objectives on this chronic setting to answer questions on the effect of Cadmium on major blood vessels (aorta) and the heart muscle. The Institutional Animal Care and Use Committee (IACUC) approved the study protocol and the study includes two groups of laboratory rats, one control group and the other is the experimental group where the animals are exposed daily to a small dose of Cadmium equivalent to 15mg of Cd/kg body weight. The Cadmium



Research Assistant, Sandra, conducting sample analysis at the lab

is mixed in drinking water in the form of Cadmium Chloride and given for 10 weeks followed by a four weeks of recovery period with drinking water without Cadmium. Tissue and blood samples are collected at different time points throughout the study period. This is an ongoing research study and some of the earlier results from this study have already been published in scientific meetings, and peer reviewed international journals. More results of this study are being prepared for publication while others are still at the lab for more analysis. Recently, one of our scientific findings well received and recognized by the scientific community, was published in a reputed journal, "Environmental Science and Pollution Research", with generous support from Qatar National Library. In summary, the study shows that long exposure of low doses of Cadmium has impact on aorta structure and function. Endothelial cell layer is a primary target for Cadmium toxicity as it alters the normal vasodilation process. Our research data provides evidence that the bioavailability of the Nitric Oxide (NO), the primary vasodilator, is impaired. NO plays an essential role in the regulation of blood pressure. The study shows that levels of Endogenous Endothelial Nitric Oxide Synthase (eNOs) inhibitor; Asymmetric Dimethyl

Arginine (ADMA) has gone through gradual increase to reach higher levels after 10 weeks of Cadmium exposure. ADMA competes with eNOS on the same substrate L-arginine and this leads to Endothelial dysfunction. Although Blood Pressure (BP) values increased after Cadmium treatment but this increment is not statistically significant when compared to similar values collected from the control group. The study suggests a role of ADMA in Endothelial dysfunction and the eventual potential increase in blood pressure. The research team continues this study to investigate and to explore using ADMA as a diagnostic tool to improve assessment of cardiovascular risk. Interestingly the histopathological analysis of aorta samples shows early signs of atherosclerosis and disruption of the integrity of Endothelial layer. The research study was supported by a fund from National Capacity Program to Dr. Hamda Al Naemi and her graduate student Ms. Sandra Concepcion Das with laboratory support by Dr. Muralitharan and Dr Kavitha. Studying the effect of Cadmium on the heart muscle proteins are still an ongoing research from the same team that also involves two undergraduate Qatari students from the department of biological and environmental sciences.

Predicting Clinical Responses to New Potential Drugs: **A New Classification Method**

Dr. Karim Nagi

Assistant Professor of Pharmacology, College of Medicine - Qatar University



Dr. Karim Nagi

A state-of-the-art research conducted by a faculty member of the College of Medicine (CMED) at Qatar University (QU) in collaboration with researchers from the University of Montreal, Canada and scientists from Pfizer Inc.,

an American multinational pharmaceutical corporation, allowed the development of a new method that could help in identifying more effective drugs with fewer side effects. Researchers hope their findings, published in the journal Nature

Communications, could be used to speed up the lengthy process of drug discovery.

Drug discovery is the process by which new therapeutic drugs are identified. It starts by screening large amounts of chemical compounds, known

as chemical libraries, for the purpose of finding a new molecule or 'ligand' that could regulate (stimulate or inhibit) in cells a specific target protein or 'receptor' involved in a particular disease. Once accomplished, ligands selected from these screens are tested in animal models of a particular disease to guarantee a high level of safety and medicinal efficacy, before studies are carried out to clinical trials and tested on human subjects.

QU Assistant Professor of Pharmacology at CMED, Dr. Karim Nagi commented by saying that, "Unfortunately, it is very unlikely that a ligand selected from the early cellular screening runs will develop into a therapeutic drug. This poor success rate in clinical trials is caused by either a lack of clinical efficacy or the development of undesirable side effects produced by those ligands when tested on human subjects, therefore making drug discovery a lengthy, challenging, and expensive process." He added, "To address that issue, we have developed a new classification method that could predict the clinical responses of ligands very early in the drug discovery process and using simple cellular responses."

Our understanding of how receptors produce their actions has significantly evolved over the past few years. Once activated by ligands, those small target proteins undergo ligand-specific conformational changes, and then act as signaling hubs that integrate a multitude of signaling cascades into cellular responses. Researchers of this study took advantage of this signaling diversity by identifying signaling pathways that should be specifically activated or

avoided to promote desired clinical responses and avoid side effects.

To further access this knowledge and apply it to drug discovery, researchers also designed a new strategy that was able to classify ligands according to similarities in multidimensional signaling profiles and to associate the resulting ligand categories with the frequency of undesired events reported in the FDA's pharmacovigilance database.

Furthermore, by using this classification method to group drugs with known clinical effects and new compounds selected from the early cellular screening runs, it would be possible to infer the clinical activities of new ligands by associating specific in vitro signaling profiles to clinically relevant responses. "Our main goal was finding a way to categorize a large number of drug candidates based on similarities in their effectiveness in triggering a multiplicity of cellular responses that help identify the therapeutic action of new compounds," said Prof. Graciela Pineyro, co-senior author of the study and a researcher at the University of Montreal.

It is important to note that this new classification method was developed by using opioid ligands (which are compounds that act by binding to opioid receptors to produce brain effects that suppress pain and increase feelings of pleasure) as prototypes. Although opioids have been successfully used to treat moderate to severe pain for decades, these last few years have seen an incredible increase in opioid prescriptions that unfortunately led to opioid misuse, abuse and deaths due to overdose.

In the United States alone, opioid prescriptions tripled from 76 million to 219 million prescriptions from 1991 to 2011. In parallel with this increase and over the same time-period, opioid-related deaths also nearly tripled. This significant increase in the use of opioids has now reached a crisis level and the risks of opioid use and misuse continue to receive global attention. Therefore, the need to develop new opioid medications that can produce analgesia with fewer side effects, like tolerance and dependence that lead to opioid overdose and death, is a request by worldwide federal governments that recognize this serious threat.

Researchers of this study accepted to undertake that challenge and have contributed to achieve several milestones in fulfilling that request. Dr. Karim Nagi said, "This discovery is expected to greatly improve the screening process of not only new opioid analgesics, but also of new drug candidates for all diseases by predicting those more effective and better-tolerated ligands."

Prof. Michel Bouvier, co-senior author of the study and a Principal Investigator of Molecular Pharmacology and Chief Executive Officer of the University of Montreal's Institute for Research in Immunology and Cancer said, "Thanks to our findings, we can now classify a large number of compounds while taking a multitude of cellular signals into account. The wealth of comparisons this provides increases this classification's predictive value for clinical responses. We think we can help patients by speeding up the drug discovery process so clinical trials can start earlier."



Discovery of the Genetic Predisposition to Super Athletic Performance

The superior performance of elite athletes has been historically considered an outcome of a special talent shaped by intensive training. The talent is now believed to be a product of additive genetic components predisposing the athlete to endurance or power trainability under the control of strong environmental cues including exercise and nutrition. The Kenyan runners who have won most distance running events in the past two decades, are vibrant examples of gene-

Dr. Mohamed Elrayess,
Research Assistant
Professor, Biomedical
Research Center- Qatar
University



The two Kenyan runners

environment interactions looking at their strict running exercises at high altitudes since childhood and yet to be determined unique genetic predisposition.

Despite this belief, identifying the genetic predisposition of super athletic performance has been rather elusive, hindered by the complex phenotype of physical performance, small effect size of the genetic components and the small study size as elite athletes are a very unique group. The sample size is a common constraint in all genome wide association studies (GWAS). Large sample sizes in tens or hundreds of thousands may be required to identify genetic differences explaining complex phenotypes such as diabetes or cardiovascular disease due to the multifactorial nature of its phenotypes. Therefore, in order to study a sufficient number of elite athletes who are few in number, an international collaboration is required.

At the Biomedical Research Center at Qatar University, we worked in close collaboration with anti-doping laboratories in Qatar and Italy to conduct the largest genetic study to date among elite athletes to overcome the issue of small sample size. Then we took a new approach to overcome



Dr. Mohamed Elrayess

challenges related to small effect size by focusing on the association between genetic variants and metabolites that offer intermediate phenotypes with a much larger effect size. We also focused on endurance sports to overcome the problem of the complex phenotype.

Our findings were very impressive. We identified, for the first time, significant associations between genetic variants and metabolites involved in physical performance in the elite endurance athletes that were not identified before in the general population (Figure 1). Among these, we identified an association between a genetic variant in an enzyme (Hydroxysteroid sulfotransferase,

SULT2A) that plays a crucial role in steroid function and testosterone precursor that is enriched in endurance athletes (Figure 2). The importance of this discovery lies in that athletes of all sports may produce similar amounts of steroids, but some of them may have better use of the produced steroid because they have this genetic variant.

This discovery is very important because for the first time there is tangible evidence of a genetic predisposition to an enzyme that gives an edge to elite endurance athletes, especially as it is linked to steroid function that is of great importance for muscle building and metabolism.

Our findings will help in deeper understanding of the molecular mechanisms underlying superior athletic performance. They can be used for screening potential athletic candidates with a significant commercial potential. They can also be used in designing future doping tests as they explain the natural predisposition to higher endogenous steroids for example. The integration of OMICS technologies is the future research tool for deciphering complex diseases and phenotypes as it gives a holistic view needed to understand such complexity.

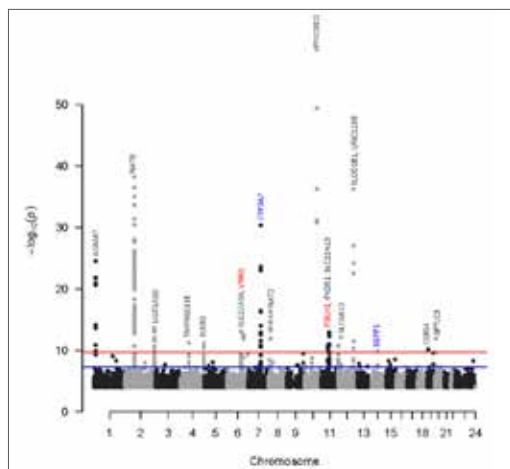

Figure 1. Manhattan plot for genetically-influenced metabolites associated with elite athletic performance.

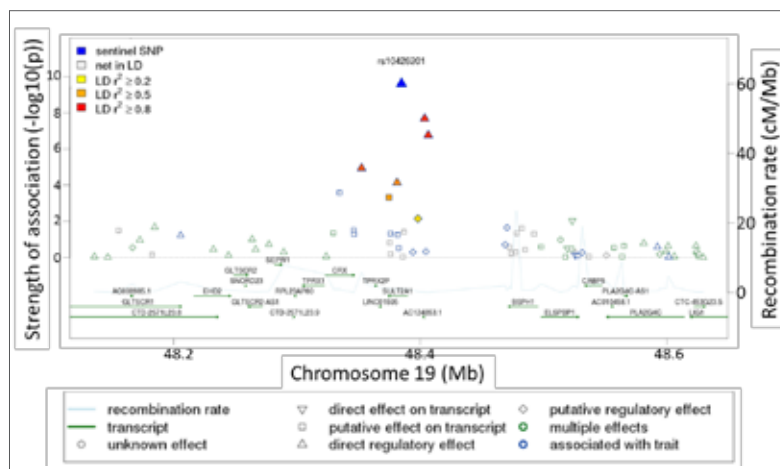

Figure 2. Regional association plot for the novel locus SULT2A1 in association with testosterone precursor (Androstenediol (3alpha, 17alpha) monosulfate).

Environmentally Powered WSN for Air Quality Monitoring

Dr. Farid Touati

**Professor of Electrical Engineering, College
of Engineering – Qatar University**

**[US Patent No.: US10, 429,367
B2, Date of Patent: Oct 1, 2019]**

This work aims at remedying a carry-over weakness in indoor/outdoor air quality (AQ) studies, which are conducted using expensive portable data loggers that allow just short-term and localized snap shots rather than a more conclusive long-term monitoring. The link between poor AQ and several health diseases has been confirmed in different studies. The need to have satisfactory air pollutants monitoring systems that can improve reliability and data availability in places where traditional monitoring methods are difficult to establish, has led to the design of numerous autonomous systems able to check indoor and outdoor air qualities.

Capillary wireless sensor networks dedicated to AQ monitoring have provided essential information on hazardous air conditions, generating early warnings to prevent danger situation for human health. The arising problem connected to capillary networks is the adoption of environmental energy as a primary and/or unique energy source instead of the replacement of hundreds or even thousands of batteries on a regular basis that leads to high costs and practical problems of device management. This work presents a multi-



Dr. Farid Touati

parametric sensor node for AQ monitoring, able to work without battery or human intervention, harvesting energy from the surrounding environment for perpetual operation. A complete autonomous system has been designed; and tested in lab, and under indoor and outdoor environment in Doha and Italy (Technology Readiness Level 5/6; TRL5/6).

TECHNOLOGY OVERVIEW

The technology is a wireless, multi-parameter environmental quality monitoring and diagnostics device that does not require batteries or grid power. The maintenance-free device can monitor in real-time a variety of AQ pollutants such as carbon monoxide (CO), nitrogen dioxide (NO₂), nitrogen monoxide (NO), chlorine (Cl₂), and hydrogen sulfide (H₂S). It can also monitor environmental conditions like humidity, temperature, and

barometric pressure. The battery-less device is powered by multiple renewable energy harvesting sources including radio frequency (RF), indoor and outdoor photovoltaic cells, thermoelectric, and piezoelectric devices.

The proven environmental quality-monitoring device is modular and scalable, such that many devices can be networked together in a cloud-based service platform. The GPS module enables sending data from multiple networked devices at different locations simultaneously. Real-time AQ data is collected and sent to an open-data platform that stores and provides open access to the data. Urban pollution mapping is enabled by integration of this system into a municipality, facilitating AQ monitoring and alerts, fostering a better quality of life. An example of measurement campaign in Doha is shown in Figure

1.ABOUT THE TECHNOLOGY

How it works?

The general structure of the system (i.e. SERENO) is depicted in Figure 2. It has been developed with the aim to reveal the air pollutants adopting low-cost and low-power design in indoor and outdoor scenarios. Different examples of chemical gas transducers can be found in the market. Each gas transducer has different operation principle,

size, accuracy and power consumption. With the use of electrochemical technology, these sensors feature both small size and fast response time.



Figure 1. An example of measurement campaign in a traffic jam in Doha (Qatar).

Nevertheless, electrochemical sensors offer several advantages for systems that measure the concentration of different toxic gases. They operate with very small currents, making them appropriate for self-powered wireless nodes. All the sensing elements are gas tailored and show resolutions around one part per million (ppm) meeting International Standards in air monitoring arena (e.g. WHO).

The integration of numerous sensors (i.e., gas sensors, barometric pressure sensor, humidity sensor and temperature sensor) and the wireless data transmission into a single sensing board has led to practical problems, especially in terms of energy consumption and energy management. To provide an autonomous source of energy for SERENO, one can consider scavenging energy from the environment with the aim to

increase the battery longevity-energy stored (rechargeable mode) or go battery-less (set-and-forget scenario). The sources of energy that have been identified and can operate together in concurrent energy recovering functionalities are as follows:

A vibration energy harvester.

Six high-performance thermoelectric generators (TEGs).

One RF power source at 900 MHz.

One indoor thin-film amorphous silicon solar cell.

Technology Benefits

Maintenance-free operation: system operates in a set-and-forget mode.

Self-Powered: environmental energy harvesting means no batteries or grid power required for operation.

Efficient: individual components have low power requirements.

Modular design: can be modified readily.

Scalable: system can grow from a single device to thousands of networked devices.

Robust: proven to be operational in harsh environments like the summers of Doha.

Aesthetic Design: public spaces will not be disrupted by system's shape.

APPLICATIONS

All the applications below are operable in an IoT-based AQ index service (Figure 3).

Indoor/outdoor AQ monitoring by municipalities, government agencies (e.g., National Weather Service), etc.

Fossil fuel power plants.

Industrial facilities.

Networked cloud-based systems with multiple data collection devices.

Transportation movement and management.



Figure 3. Mobile applications of SERENO

DEVELOPMENT STATUS

Researchers have successfully fabricated this technology and conducted pre-commercialization testing in a laboratory, and then the outdoor environment in Doha and Italy for extended periods raising it to TRL5/6 (technology readiness level 5/6).

PATENT PROTECTION

This technology is protected under the US Patent No.: US10, 429, 367 B2, Date of Patent: Oct1, 2019.

LICENSING OPPORTUNITIES

Qatar Foundation is offering this technology for license. For more info about this

Technology, please contact technologies@qf.org.qa.

ACKNOWLEDGMENT

This publication was made possible by NPRP grant # 6-203-2-086 from the Qatar National Research Fund (a member of Qatar Foundation). The statements made herein are solely the responsibility of the author.



Figure 2. 3D view of SERENO (PCB top view) where the 6 (version 1, left side) or 4 (version 2, right side) gas sensors are shown. Version 2 features a local display.



A Comparative Jurisprudential (Fiqh) Study: **Women's Rights and Qatar's Family Law**

**Wadha Nasser Al-Hajri, Amal
Abdul Rahman Abdullah,
Sara Saad Al-Otaibi, Qumza
Saeed Al-Marri, Maryam Ali
Al-Senaid**

**Graduate Research for
Undergraduate Study,
Fiqh and its Foundations
Department,**

**College of Sharia and Islamic
Studies - Qatar University**

Allah says in His Glorious Book
(The Quran)

[And of His signs is that He
created for you from yourselves
mates that you may find tranquility
in them; and He placed between
you affection and mercy. Indeed
in that are signs for a people who
give thought] [Surat Al-Room (The
Romans): Ayah 21]

Allah - Glory be to Him - has
legalized marriage and made it
a custom among people ever
since the beginning of creation.
Allah Almighty has described
it as a "heavy covenant" for
its importance and the great
benefits it entails such as
protection of chastity, keeping
offspring, protection of society
from dissolution and tightening
of family ties, and strengthening
the bonds of love and affection
between relatives. Sharia,

however, has tied the fulfilment of the purposes of marriage to the commitment of the spouses to their responsibilities and duties imposed on them.

This research focuses on the subject of marital obedience and its provisions in Islamic Fiqh. Then that which is concluded from the research and scientific induction is compared to the Qatari Family Law issued in 2006.

In the fall of 2019, a group of female students from the College of Sharia and Islamic Studies undertook a comparative Fiqh study on the topic of marital obedience in Islam. This is one of the issues that occupies a large space in Qatari society given that religion and culture attach great importance to the obedience and respect of a woman towards her husband. The research followed several scientific approaches, the most prominent of which are the comparative and analytical approaches. The work team consisted of five students from the Department of Fiqh and its Fundamentals, namely: Amal Abdul Rahman Abdullah, Sara Saad Al-Otaibi, Qumza Saeed Al-Marri, Maryam Ali Al-Senaid and Wadhi Nasser Al-Hajri. The research was conducted under the supervision of Dr. Marouf Bara and the Head of the Fiqh and its Foundations Department, Prof. Dr. Saleh Al-Zanki.

The research is divided into eight themes: the discussion starts in the first and second themes with an introduction about the concept of obedience, its divisions and rulings. Then the position of women in Islamic legislation is explained and compared to what was before Islam in the third theme. In the fourth, fifth and sixth themes, the rights of spouses and the limits of obedience are reviewed. In the seventh theme, the issue of conflict of due obedience is discussed. Then the implications of the wife's non-compliance with marital obedience to her husband

in Islamic Fiqh and the Qatari Family Law are discussed in the eighth theme. Furthermore, the preparation of the research took approximately three months.

The study deals with the provisions of "marital obedience" from the perspective of the four schools of Islamic Fiqh approved by the Sunnis, and comparing them with the texts mentioned on these issues in the Qatari Family Law of 2006. The researchers faced some difficulties, perhaps the most important of which are the limited timeline for completing the study, and the lack of previous studies addressing the subject in relation to the legal aspect.

The importance of the research lies in tackling many of the problems raised about the topic of marital obedience, explaining its truth and its limits, and how to implement it in a legitimate manner. This is in addition to clarifying the conditions and controls for marital obedience and the Sharia provisions related to it, and reviewing the opinions of the four Fiqh schools in that regard. The research also discusses the provisions related to the conflict of due obedience, such as obedience to parents and obedience to the husband, with obedience to Allah - Glory be to Him - and clarification of the Sharia effects of non-compliance with the command of Allah, and then comparing that with the Qatari Family Law of 2006.

The research also aims at explaining the position of women in Islam, responding to some suspicions related to the rights of Muslim women, and explaining how Islamic legislation honors and preserves her freedom and rights. The research further points that what Orientalists claim is that marital obedience is a law of enslavement is far from being true. Rather, obedience is a principle based on justice, established with restrictions and conditions for the husband and the wife to preserve their rights to

enhance the spirit of affection and intimacy between the spouses and contribute to the success and continuity of this bond.

At the end of this research, the researchers obtain several results, the most important of which are:

Marital obedience is purely a matter of Sharia, as keeping to it is a matter of obedience to Allah first before it is to the husband. However, the consensus of the Islamic jurists has determined that there is no obedience to a creature in the disobedience to the Creator. Thus, marital obedience has been mandated to preserve the rights and protect the family system.

Scholars agree that it is obligatory to obey the guardians, the parents and the husband. They, however, differ in the manner of such obedience in two directions: the first is that it is obligatory, and the second is that their obedience is obligatory only in relation to their rights, which was reported by Ibn Taymiyyah, Ibn Najim and others.

On the issue of conflict of obedience, the researchers suggest that the majority of Islamic jurists give priority to obedience to Allah - glorified and exalted may He be - over obedience to the husband. Likewise, the students outbalance the view of the majority of Islamic jurists in the matter of conflict of obedience due to the husband with that to the parents, in that obedience to the husband has priority over that due to the parents since it is derived from his ward ship.

Finally, the researchers concluded that the Qatari Family Law 2006 derives most of its texts from provisions of Sharia. Thus, its articles are in accordance with the Sharia, especially in matters related to marital rights and the implications of the wife's disobedience.

Mobile Government Services and Resident Satisfaction: Evaluation of Kahramaa Mobile Services in Qatar

Students: Mohammed Adel Al Najjar, Assem Alabdelqader, MBA Program,
College of Business and Economics - Qatar University

Supervised by: Prof. Emad Ahmed Abu-Shanab, Professor of Information
Systems, College of Business and Economics – Qatar University



Qatar General Electricity and Water Corporation (Kahramaa)

Introduction:

Recent studies indicated that smartphone penetration in many countries has reached unprecedented levels, while mobile technology prices continue to decrease. Such trend makes these platforms more accessible to lower-income people. Faced with this new reality, some policymakers believe that e-government websites are no longer sufficient and should be supported by mobile applications. More and more citizens can use IT tools

to voice their concerns about the issues they deem important to the public. It is important to note that the ever-growing popularity of mobile technology changed the approach that most governments are taking for the delivery of public services.

Governments are evaluating the efficiency and effectiveness of mobile technology when adopting it for offering public services. Mobile technology is an important channel for reaching citizens, but it should satisfy business concepts like any

other IT venture. New initiatives related to smart cities made mobile technology, Internet of things (IoT) and artificial intelligence (AI) important tools for the success of such ventures. Mobile technology can add much value to the efforts government pursue to attract citizens to be active in public participation and to benefit from public services. Based on this direction, this paper will explore Qatari citizens' perceptions regarding mobile technology use for public services. Such direction offers insights to government leaders on the latest trends in mobile government offerings and the strategies that better serve and engage citizens, their own employees, and other businesses in the country.

This study will focus on Qatar General Electricity and Water Corporation (Kahramaa) mobile application as one of predominant citizen-oriented apps used in Qatar. This in-depth evaluation of mobile services will investigate the major predictors of citizens' satisfaction in m-government. This study takes a stand that mobile technology's effectiveness and efficiency are major predictors that influence customers' satisfaction towards



Mohammed Adel Al Najjar - Student



Assem Alabdelqader - Student



Prof. Emad Ahmed Abu-Shanab

m-services. Finally, six predictors are explored to predict the efficiency and effectiveness of such technology.

The following section will explore the literature related to the assumed research model to better understand the constructs and their relation to the ultimate dependent variable. Section three will describe the research method. Section four will describe the data analysis and its discussion. Finally, our conclusions and future work are stated at the end.

Research method:

This study explored one of the major mobile government applications that serves the residents in Qatar. The application under consideration is Qatar General Electricity & Water Corporation Kahramaa mobile services (KMA). The research tried to answer few questions pertaining to the level of satisfaction of Qatari population towards Kahramaa mobile services. The research team pursued an answer for the following research question:

What are the major factors influencing the satisfaction of users with KMA services?

The previous literature review explored the m-government application in Qatar with an

aim to link it to the existing literature related to efficiency and effectiveness. The majority of research focused on the adoption theories and the attitude side. This study will integrate two major models related to system usability to explore the major factors influencing users' satisfaction. Shackel (1991) focused on engineering usability, and the relativity of its concept. The author provided four major features of usability and they are effectiveness, learnability, flexibility and attitude. On the other hand, the Nielsen Model (1993) considered usability as a major attribute that affects the adoption of a system or application. The researchers provided support for five features of usability and they are learnability, efficiency, memorability and accuracy. The researchers decomposed the acceptability into practical and social adoption.

Our focus in this study revolves around the efficiency and effectiveness of applications and how they will influence satisfaction. This study tried to carefully inspect the m-government characteristics and the related literature to efficiency and effectiveness to come up with suitable features of both. In addition, we need to be careful not to include similar

dimensions when adopting (integrating) two models. The proposed research model depicts our proposition in this regard.

Our investigation concluded to six factors that were reported in the literature and would influence the efficiency and effectiveness of m-government. Effectiveness is about doing the right things, which includes doing transactions in an accurate, reliable and usable fashion. On the other hand, being efficient is about doing things the right way, which includes having m-government services available, accessible and in a timely manner. Saying that, we depicted our conceptualization in the following research model (Figure1).

Data analysis

Research Instrument

This study utilized previously used items for measuring the research variables, where a survey instrument was built to test the model and research hypotheses. The instrument utilized a 5-point Likert scale with 1 representing a total disagreement and 5 representing a total agreement. Based on such scale, a mean value between 1 and 2.33 represents a low perception of the item, a mean between 2.33 and

3.66 represents a moderate agreement with the statement, and a mean between 3.6 and 5 represents a total agreement. The instrument included three

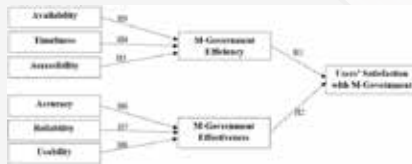

Figure 1. Proposed research model



Figure 2. The path model

sections; the first introduced the research topic and the conditions of research and sampling process (voluntary and random sampling).

Results shown in Figure 2 indicate significant influence of usability and accuracy on m-government effectiveness (beta values are 0.322 and 0.316, respectively). The significance of the beta values is supported by two t values (3.889 and 2.898, respectively). Finally, two variables failed to be significant predictors of efficiency and effectiveness (Accessibility and reliability). The coefficient of determination for the prediction of efficiency of m-government is 0.411 (which means that availability and timeliness explain 41.1% of the variance in efficiency). In addition, the coefficient of determination for the prediction of effectiveness of m-government is 0.617 (which means that usability and

accuracy explain 61.7% of the variance in effectiveness).

The ultimate dependent variable in the research model is users' satisfaction in m-government (reflecting KMA use). The estimated contributions of both effectiveness and efficiency of m-government is significant with beta values equal to 0.398 and 0.456 respectively. The significance of the beta values is supported by two t values (2.479 and 3.583 for both effectiveness and efficiency respectively). Both variables contributed by 65.8% of the variance in users' satisfaction when using m-applications. Kahramaa need to improve their mobile application concerning its availability, timeliness, accuracy and usability to render effectiveness and efficiency. Such layer of improvement will improve users' satisfaction. On the other hand, reliability and accessibility are not significant factors, where users indicated less importance of special needs issues and the reliability of the website. Even though the company works with a service that is crucial to Qatari residents, the users focus revolved around

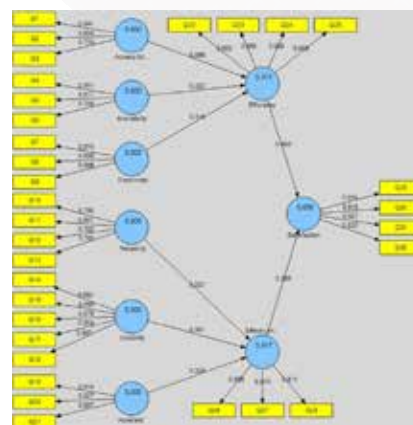

Figure 3. The bootstrapping technique results (preliminary model)

the first four constructs. Both efficiency and effectiveness were significant factors in predicting users' satisfaction.

Conclusion:

This study tried to identify the factors influencing users' satisfaction with m-services in Qatar represented by Kahramaa mobile application (KMA). The literature review conducted identified few factors that would be of great influence on users' satisfaction and are all related to the application features. The proposed research model included eight hypotheses, where it assumed that accessibility, timeliness, and availability are significant predictors of m-government efficiency. In addition, accuracy, reliability, and usability, are significant predictors of m-government effectiveness. Finally, m-government effectiveness and efficiency are major predictors of users' satisfaction. Results indicated high perceptions of all variables included in the model, and specifically satisfaction. Such result demonstrates that Qatari residents are satisfied with the service provided by Kahramaa through its mobile app. Results also supported the bivariate correlations of all variables, but when testing the overall model, two variables failed to support the dependent.

This study is the first to explore system features on a Qatari mobile application and specifically KMA. The study yielded significant results and supported the proposed research model except two variables. This study provided valuable insights to researchers and practitioners on the diverse dimensions formulating each variable. In addition, it provided public officials with a new foundation on the factors influencing users' satisfaction. For more details on International Journal of Electronic Government Research, Volume 15 • Issue 2 • April-June 2019, visit: <https://orcid.org/0000-0002-2826-883X>.

Interview with a Student:

Mashaal Al-Badr PhD Student

We reserved these pages for the community of graduate students. We are going to learn about the excellent academic environment provided by Qatar University for its students, and discover students' individual capabilities. We welcome in this issue Mashaal Al-Badr, a PhD student in Biological Sciences Program.

Will you please introduce yourself? And tell us about the reasons behind choosing this field of specialty?

My name is Mashaal Ali Al-Badr, I got a bachelor's degree in Biological Science with minor in Biomedical Sciences in 2007. I got a master's degree in Laboratory Management in 2018. Currently, I am a PhD student in my first year of Biological and Environmental Science. I worked at the criminal laboratory of the Ministry of Interior in the Department of Criminal Biology until I became an accredited expert in the field of biology and DNA profiling before Qatari courts. After that, I shifted my career to the research field and I joined Biomedical Research Center in 2018. My research work has become a new passion in my life and I chose the department, which I graduated from, because I love this field so much.

What is the theme of your research?

The theme of my research can be summarized as using Nano Particles in treating Pulmonary Artery Hypertension Disease. I obtained a funding grant from Qatar National Research Fund (QNRF) for this research.

How would your study contribute to research in its scientific field?

Using Nano Particles Technology in the treatment of diseases is one



Mashaal Al-Badr

the challenges faced by a great number of researchers in this field because of its infinitesimal size, as well as lack of knowledge on the extent of its toxicity and the reaction of the immune system towards it being foreign bodies. There are other challenges as they are one of the modern fields whose details have not been studied yet. This is what I am trying to overcome in my research and study.

Tell us about your work at the Biomedical Research Centre (BRC), and is it at the core of your specialty?

There are many similarities between my field of specialty and my work. I have been working on medical researches using Zebrafish at BRC. However, my study may oblige me to use another animal model to study Pulmonary Artery Hypertension disease which may enrich my research knowledge.

Do you see yourself in the future to be amongst the leaders in your field?

I see myself - by Allah's will - as a distinguished Qatari scientist specializing in using Nano Particles Technology in the medical field. I beseech Allah to guide me to succeed in that, as this path is full of challenges, which I have to overcome.

What is your assessment of the availability of scientific references and resources at the library of Qatar University that would boost scientific research?

Qatar University's library is one of the well-established libraries. It is rich with scientific resources. Furthermore, it provides students with many printed and electronic references for free. Moreover, student support services at the library are excellent and prompt.

How can Qatar University attract more students based on your experience?

I think that the university has already attracted many students either from Qatar or beyond, and that is because the university is keen to raise its international ranking and it succeeded in that regard through offering scholarships and research funds. These efforts helped increase the number of graduate students enrolled in the University.

What does Qatar University offer graduate students to prepare them for the future as leaders and scientists?

All potential resources provided by the largest and prestigious universities around the world are available at Qatar University. Here we find the best academic staff and research funding, so we get quality education and application. There is no doubt that field training and internal and external interims provided by the University contribute to the development of students' scientific personality.

What do you suggest to improve the program?

I wish to see the program accredited by a world accreditation entity, because it is one of the best and most significant programs.

Interview with Researcher: Prof. Ayman Saleh - College of Sharia and Islamic Studies

Dr. Ayman Saleh, would you please introduce yourself?

Well, I am Professor of Islamic Jurisprudence and its Foundations at the College of Sharia at Qatar University. I got a PhD from the University of Jordan in 2001 and was placed in the first class at the university level. Furthermore, I was awarded the prize of Engineer Walid Barakat for Academic Excellence. I have worked for a number of Arab and foreign universities.

Tell us about your experience of joining College of Sharia at Qatar University?

I joined Qatar University in autumn, 2012 as an Associate Professor. I was promoted to the rank of Professor last year (2019). In addition to teaching, I am currently working as Graduate Studies Coordinator in the Department of Islamic Jurisprudence and its Foundations.

How does the College of Sharia and Islamic Studies depend on research activities as a way to transfer knowledge to students? What are your research interests? Would you please tell us about your latest projects and research publications?

The message of the College of Sharia and its programs view qualitative research as a main task of the College. This is reflected in the structure, teaching methods, and evaluation of these programs. Full courses, whether at the undergraduate or graduate level, have been tailored in order to teach students, the research methods skills, in addition to making “research” an essential element in the student’s evaluation in all graduate courses and many of the



Prof. Ayman Saleh

undergraduate courses as well.

As for my research interests, I focus on the Science of Islamic Jurisprudence (Usul Al-Fiqh) and its applications, especially in the field of family and transactions in Islamic jurisprudence.

My last research is a rigorous fundamentalist study of a research problem in justifying Sharia rulings, which has a great impact on the contemporary Islamic jurisprudence issues. A series of referred research has been completed from this project, the most recent of which was issued in March 2020 on the benefits of “Sharia” judgments. Qatar University Press will issue an important book, which addresses an aspect of fundamentalist causes in the field of family Islamic jurisprudence. This book will be published under the title: Applying DNA Profiling for the Establishment and Negation of Paternity and Disclose Its Fallouts: New Islamic Jurisprudence Perspectives.

What is the importance of your book “Pedigree examination by DNA Testing” for research

process, especially for students researching in this field?

The importance of the book arises from three things:

1. The importance of its subject related to DNA Testing and its impact on the issues of the child’s attribution to his father. Today, Muslims need clear and authoritative answers to the position of Islamic law in this field, especially with the widespread use of people to this testing, which is available locally or via the Internet at relatively inexpensive prices.

2. The importance of the book’s theory, which stipulates that it is necessary to apply the results of this testing in cases of negation of paternity issues on a large scale. However, the family laws do not follow this rule in most Arab countries, and there is no fatwa issued by Muslim scholar-jurists “Fuqahā.”

3. The book was unique in its approach at dealing and establishing the origin of the issue through linking it to the issues of justification rules, especially the topic of Wise Reasoning.

What is the position of the book theme in the context of contemporary Islamic jurisprudence references?

Applying DNA profiling for the establishment and negation of paternity, has preoccupied Muslim scholar-jurists-“Fuqahā” in the modern age. Various conferences and symposiums were held, jurisprudential forums were convened, dozens of abridged and detailed research papers were written, and scientific theses were registered in order to study and discuss the issue.

It can be said that these studies reflect a near consensus about the permissibility of the application of DNA profiling in the determination of paternity, in principle. However, they differ on the scale and extent of this application. These studies could be divided into three general categories; based on their position:

First, the 'broad' position, which supports the broadest application of the DNA profiling to prove or negate paternity. They even, in cases of conflict, give DNA profiling priority over "Al Firâsh", "established paternity of married husband and wife" as the basis of paternity, and regard it as obviating "Al-Li'aan", "sworn allegation of adultery committed by one's spouse" in negation of paternity.

Second, the 'narrow' position, which supports the application of DNA footprint only in the special cases of suspicion of or dispute over paternity, by analogical reasoning "Qiyas" to "Al-Qiyâfah", "the studied ability of some (particularly the ancient Arabs) to discern genealogical affinity by examining, observing, and comparing bodily features; tracking the resemblance between father and son". For this category of studies, DNA testing does not go beyond the effect of "AL-Qiyâfah" in establishing or negating paternity. This is the position adopted by the majority of studies. Most of the legislations and jurisprudence in Arab countries support this position.

Third, the 'intermediate' position, which argues that DNA testing has priority over all traditional modes of Paternity Determination in Islamic Law, "Sharî'ah", except for "Al Firâsh". However, the scholars have different positions with regard to Al-Li'aan as the basis for the negation of paternity. Some "Fuqahâ" give it priority over "Al-Li'aan", and thus make it the first basis for the negation of paternity; thereby preventing the husband from negating priority by "Al-Li'aan". For others, DNA testing is used only to prevent the husband from negating paternity by means of "Al-Li'aan"; without viewing DNA profiling as the sole basis

for the negation of paternity (i.e. to be applied solely without "Al-Li'aan"). A third group of "Fuqahâ" approve the use of DNA testing as a supporting proof just to assure the husband and prompt him to voluntarily renounce the decision to negate paternity by means of "Al-Li'aan".

The book supports the 'broad' position about the application of DNA profiling in the establishment and negation of paternity. This study stands out from previous studies of this position because of its approach, characterization, and the way it establishes the origins; as well as the counter arguments it presents in response to the objections of the advocates of differing views. Not to mention its modernity; approaching new relevant topics that were not studied before in these mentioned studies or elsewhere.

What are the most important research questions that will be answered in the book?

This study answers some of the important lingering questions of the present-day on that issue. In-depth studies have not addressed the majority of these questions; including:

Is the application of DNA Profiling in paternity testing legitimate, in case of manifestly established paternity according to "Al Firâsh" or otherwise?

To what extent should DNA testing affect the authority of other modes of paternity determination; namely "Al Firâsh", Testimony and Acknowledgement of paternity?

What is the characterization of paternity order according to the Principles of Islamic Jurisprudence? What is the position of the Principles of Islamic Jurisprudence with respect to DNA profiling?

What are the grounds for granting DNA testing the status of definitive presumptions, despite the possibility of error that may occur in this connection?

Are the conditions for the application of "Al-Li'aan" still applicable in our days? To what extent could the discovery of DNA

testing be effective in obviating the justification for the resort to "Al-Li'aan" for the purpose of negation of paternity?

Is the Ruler entitled to establish a general regulation for paternity verification?

Is it lawful for the examiner to reveal to the examined person the results of his/her paternity/filiation DNA analysis, especially when these results are shown accidentally rather than deliberately?

Is it possible to study the book in universities?

The book is a good model for dealing with the contemporary Islamic jurisprudence (Fiqh) issues through linking them to the jurisprudential principles that could be built upon, and this style of close linking is not common in studying contemporary Islamic jurisprudence issues that focus mostly on the sub-fundamental rather than the fundamentalist side. Hence, there is a sort of importance of including the book in the references of graduate courses that deal with approaches to study contemporary Islamic jurisprudence (Fiqh) issues. In addition to the above, the book can be an important reference in family Islamic jurisprudence (Fiqh) courses and its contemporary issues.

What are the benefits of the book to the society?

It is hoped that legal professionals and decision-makers in the field of family legislation in various Arab and Islamic countries will read the book and benefit from the recommendations it reached - supported by deep arguments, which if adopted, will change many articles of the family laws in the field of paternity.

What are your future research plans?

I will complete research on some issues that are still considered problematic in the field Justification of Rulings. I am going to introduce practical applications of these issues such as we did with the issue of application of DNA Profiling in Paternity Testing.

A Story of a Center: Gulf Studies Center, College of Arts and Sciences- Qatar University

Dr. Mahjoob Zweiri, Director of the Gulf Studies Center, tells us about the Center in the following interview.

Dr. Zweiri, tell us about the Center's mission and vision?

With regard to the Gulf Studies Center's vision and mission, the Center is an academic research unit affiliated to the College of Arts and Sciences. Its vision is that the Center be distinguished in scientific research and education in the field of Gulf studies, whether locally, regionally or internationally. The Center also seeks to be the preferred choice for researchers, experts and graduate students working in the field of Gulf Studies locally, regionally, and internationally. Of course, the Center aims to stimulate the development of education and scientific research in political, economic and social issues related to the Gulf region. This is as well as providing innovative academic research; to enhance interdisciplinary studies, on the Gulf issues and enhancing the regional studies within the subject of interdisciplinary research. The Center also aims to participate in a wide range of research activities with local, regional and international partners. This mission, vision and goals of the Center must naturally represent the real motivation and the real incentive behind everything it does, whether it is in the subject of its studies



Dr. Mahjoob Zweiri

or the topic of its activities. The importance of what the Center does in terms of producing knowledge either by research or the graduate studies program is not hidden. In conclusion, The Center aims to produce knowledge on this important region and its importance increases in that it provides knowledge from within the region, which is not customary as studies of this region are done elsewhere. The GSC comes essentially from within the Gulf region but from Qatar.

What is the Center's organizational structure, and what are its research attempts?

The Center focuses on three important research areas that may be considered as a section. The first area is politics and security of the Gulf. The second is energy and economies of the

Gulf, and the third addresses culture and society of the Gulf region. These three areas form the core and the basis of research and studies whether produced by faculty members or through conferences, workshops and seminars as well as theses produced by graduate students. Master's students, for example, have produced about 55 master's theses, which mostly deal with these research areas, including politics and security in the Gulf, energy and economics, and cultural and societal issues. Of course, these research endeavors are part of the contribution to the production of knowledge related to the significant Gulf region. It becomes increasingly important to know that this knowledge production mostly comes in English as the graduate program is offered in English. Moreover, some studies are translated into English especially those produced in Arabic. Naturally, some studies are produced in Arabic but it could be said that production in English is more important in the sense it gives QU more visibility not only locally but globally as well.

Does the Center cooperate with external research institutions and agencies, and to what extent are they fruitful?

The Center has cooperation ties inside Qatar and beyond. Internally, we cooperate with Ministry of Foreign Affairs and other entities such as Al-Jazeera



Part of the center's activities: The 4th Annual International Conference of the GSC "Geopolitics of the Gulf Energy: Responding to New and Old Challenges"

Network, Doha Institute for Graduate Studies, Georgetown University and Northwestern University in the Education City as well as College of Social and Human Sciences at Hamad Bin Khalifa University. Internationally, we cooperate with the Royal Institute "Chatham House", the Center for Advanced Arab Studies in Georgetown, Durham University, and with other research centers in France, Spain and Germany. We also have cooperation with Singapore, China and Japan. There is close cooperation with the Waseda University in Japan and with the Beijing University in China. These relations help organize events and hosting of professors and researchers, whether in Qatar or in the organizing countries. This cooperation often results in joint research projects, such as joint papers with the Institute for Middle Eastern Studies located at the National University of Singapore, and has also resulted in a plan to write a book on the history of Qatar in Chinese, in cooperation with the University of Beijing, as well as with Waseda University. There is now a plan to hold an international conference on the Gulf and the Middle East after a decade has passed since the Arab Spring incident. We confirm that relations with institutions and Centers benefit us internationally in various ways, namely the global presence as well as the contribution of our researchers

and the benefit of our students from these studies, as well as achieving the international presence in the international academic scene. The Gulf Studies Center is the only Center in the world that actually has a graduate program that grants master's and PhD degrees in Gulf studies. Thus, the affiliative and healthy relationship between the Center's research areas and the disciplines of the academic program make relationships with its external counterparts more distinctive.

What are the distinctive features of the GSC?

The Gulf Studies Center enjoys many distinctive features. First, it is a Research Center based on a graduate program. In other words, we are the only Research Center in the field of humanities and social sciences that is based on a graduate program in both the master's and the PhD. Both degrees belong to the same research area. Therefore, there is a robust academic knowledge production according to the highest standards through the academic program. There is another research production carried out by expert researchers in the Center. Another distinctive feature of the Center is that, it is the only entity that addresses regional and interdisciplinary studies. The Gulf studies are carried out based on a criteria focusing on the Gulf region based on geography and geopolitics. Other studies are also

carried out within the concept of interdisciplinary studies. Therefore, studies are done from multiple dimensions: historical, economic, social, security, and anthropology. They are not based on a single epistemic branch, but rather on multi-knowledge, multi-dimensional and multi-angled aspects. Production of knowledge here is proportional and sometimes exceeds the production of traditional knowledge today that does not belong to one specialized field. In other words, it is not possible to understand a specific event and a specific phenomenon in the Gulf region only through one specialized branch such as sociology, history or politics. It is necessary to look at the rest of the fields of knowledge. The program provides this because the nature of academic courses and curricula gives this comprehensive academic dimension in understanding the phenomena, events and developments from multiple dimensions. As such, they are deeper, more credible and accurate in reading and analyzing events and developments. This is an important distinctive point for the Gulf Studies Center. Another point of distinction is that it exists in the Gulf, in the State of Qatar. A State, which is active in the field of international politics and the field of regional politics. The State of Qatar represents a model whether it is related to interest in education, or in achieving global



Part of the center's activities: Symposium on Yemen's changes and their effects on the Gulf Region, organized by the Gulf Studies Center

security and stability, and it plays a fundamental role in the topic of diplomacy and mediation in the world to resolve disputes. These dimensions increase the importance of the Gulf Studies Center and its presence in the State of Qatar. Furthermore, what increases its importance is its international diversity. We have more than 24 nationalities of students and researchers who work in the Center and this makes it more global. What distinguishes the Gulf Studies Center as well is the cultural diversity, which makes it an important space for ideas and their discussion within an academic environment that respects academic freedom.

Have your programs received accreditation from external agencies, how was that achieved, and how important are they?

The Gulf Studies Program does not need academic accreditation, as it is part of a state university. Of course, at the beginning, our academic programs underwent an international reviewing process by professors from institutions and universities of a high level. They are also subject to follow-up every four years and a review of the plan. There is close

monitoring and follow-up to the issue of quality, whether it is in the decisions, the academic process or the quality of the theses that are subject to external review. This makes the quality a basic criterion for the knowledge produced by the Gulf Studies Center. Maintaining quality and observing international standards and periodic review and benefiting from review by renowned professors and universities ensure high quality in academic work or in the academic output presented by students who graduate from the program.

Has the Center published any books? In what fields?

Research areas and most of the studies in the Center focus on the so-called (monograph), which are long articles found on the Center's website published by researchers at the Center or specialized professors/ scholars. These relate to various studies, including Qatar's relations with Mexico, with Japan, issues related to the Gulf crisis, the issues of Iran's relationship with the Gulf, the United States and various studies. Presently, we are in the process of documenting a book on the Gulf crisis, 2017. It will be published by a well-

known publishing house, which is "Springer". It will be published late 2020, titled (Gulf Crisis 2017: An Interdisciplinary Study). The book contains 18 chapters on the crisis in all its social, economic, security, political and economic dimensions. We also have books to be released soon, addressing the political economy of the Gulf region, a book on Iranian foreign policy and another book on the contemporary State of Qatar (state and society). Of course, there are other books in the pipeline during the next four years. The Center will produce about 8 to 12 books on the Gulf region in the fields of politics, economics and social issues. Of course, not to mention the production that faculty members contribute in scientific journals or chapters in books, which are in fact, large in number. We are proud that our students produce theses published by recognized publishing houses such as (Palgrave) and others. Talking about publishing, it must be noted that we now have a series under the title of "Gulf Studies" with Springer Publishing House, which will publish studies related to the field of Gulf Studies. There is an agreement between the Gulf Studies Center at Qatar

University and Springer, which is a well-known publishing house with a global presence, so this series of Gulf Studies will also increase the international status of the Gulf Studies Center.

How do you assess students' engagements in scientific research?

The participation of students, of course, is very important because our students are graduate students and therefore they produce theses. Before they graduate, they are required to submit researches. These are the graduation requirements, whether they are master's or PhD theses. Thus, our students have many achievements in studies and research either independently or in collaboration with their professors. We mainly focus on this. Of course, we also encourage them to publish their theses if there are opportunities to do so. Therefore, their presence is very important in the subject of scientific research, because as I said, our primary goal is to produce knowledge. Professors and students cannot only do production of knowledge. They have very good ideas, new visions, and therefore, there is an attempt to benefit from these experiences through their effective participation.

Does the Center participate in external conferences and seminars, how do these participations contribute to achieving the goals of the Center?

External events, conferences, and seminars are an essential part of the Center's work. These events aim first to create a space for discussion among many experts and professors in areas related to Gulf studies. The center organizes an annual conference, and this year it will be the fifth in row. Every year, the conference takes a different dimension. Sometimes, it focuses on social issues, sometimes on political issues and may extend

to economic and energy issues. The fourth annual conference was on the topic of energy and economics in the Gulf. As for the fifth conference, which will be held in late 2020, it will cover external societies in the twenty-first century. It is an international conference where we usually receive tens of participations from which we choose the best. The annual conference proceedings are usually published in a book. We also hold one-day workshops focused on specific issues. These also take place periodically, whether on campus, in cooperation with other departments at the university or even in cooperation with institutions within the State of Qatar. We are always keen to render important seminars, either in the context of knowledge production or in the context of policymaking. Therefore, we work with respective institutions in the government to meet their needs in some issues that concern them such as issues related to the Gulf, in terms of security, politics, economics, etc. We work with relevant institutions on these seminars, whether open or closed, to discuss issues of primary concern to the State of Qatar. Experts and specialists discuss these issues and try to recommend useful policies that help decision-makers develop perceptions on how to tackle such issues. We have short events, which host specialists in the Gulf. These are internal seminars that we hold to maximize the experience of students by giving them the opportunity to listen to experts in the Gulf region, whether from inside or outside the region. Our researchers also participate in conferences outside Qatar in international and global forums. This would also enhance the Center's global visibility as well as that of Qatar University at large. We believe that these conferences enhance our role as a Center and as a University

in producing knowledge related to the Gulf region. We also see that our presence in conferences abroad also enhances such participation, rendering us an active contributor to the issue of producing knowledge regarding the Gulf region. The main objectives of the Center focus on the topic of knowledge production, enhancing the presence in the international community and the international academic scene. This is only strengthened through events and conferences. Finally, it is worth noting that the Gulf Studies Center in its academic programs and research sector remains a landmark in the field of social and human sciences at Qatar University as it focuses on one research area linked to an academic program. This is the only Center in the world playing such a role, and this in itself is a point of excellence in the field of soft power projection for the State of Qatar.

Do your graduates hold important positions in Qatar?

We have many students working in institutions within the State of Qatar, specialized in foreign policy, diplomacy, the economic sector, as well as the media. There are many students pursuing their doctorate degree in the same field.

What is the Center's role in realizing the Qatar National Vision 2030?

The Center's vision, goals, and targets are a reflection of the University's vision, which is consistent with the Qatar National Vision 2030. We focus on excellence in sectors such as knowledge-based economy by providing world-class education that serves the local community and contributes to human knowledge, especially knowledge related to the Gulf region. The Gulf Studies Center also contributes to enhancing human capacities by graduating Qatari students specialized in the field of Gulf Studies.



Achieving Green Building in Qatar Through Legal and Fiscal Tools

Dr. Jon Mark Truby
Director of the Center for
Law and Development,
College of Law- Qatar
University

Dr. Aaron Richard Harmon
Clinical Assistant Professor
of Law, College of Law –
Qatar University

Problem

As the world's highest per capita consumer of water and emitter of CO₂, Qatar is seeking to promote sustainable development as it grows. It is also a state with a deep interest in mitigating the effects of climate change, given the severe and irreversible changes that would make life in Qatar unlivable if temperatures exceed those specified in the Paris Agreement.

With inefficient buildings being an overwhelmingly large contributing factor to a nation's emissions levels (40% in the EU), targeting this contributor with law and policy measures is a relatively effective way to mitigate climate change over time.

Importance

The paper demonstrates how Qatar can achieve the triple benefit of lower emissions, reduced energy costs, and increased energy independence through law and policy reforms.

Green construction has been mandated for certain developmental projects by regulations in the 2014 Qatar Construction Specifications.

Sustainability and conservation of natural resources has been identified as instrumental to national security in guiding documents such as Qatar National Vision 2030 and the Qatar National Development Strategy.

Legal issues related to biodiversity in water in Qatar are also under-researched, and called for in both the Qatar National Development Strategy (QNDS) and the Qatar National Research Strategy.

Solutions

The paper demonstrates progress made and recommends reforms to ensure appropriate measures are in place to incentivize a wide-scale program of green fiscal reform in the existing homes and new homes.

High performance green buildings consume less energy and water and use resources more efficiently. As a result, they also reduce CO₂ emissions. LEED® certified buildings consume between 10% and 25% less energy and 11% less water and emit 34% lower greenhouse gases than similar conventional buildings. As a result, LEED® buildings have led to a reduction of 34% of total U.S. CO₂ emissions.

Qatar was one of the first countries in the Middle East to establish a Green Building Council chapter to promote



Dr. Jon Mark Truby

LEED® certified projects and education. It has also independently developed one of the region's premiere green building certification systems, the Qatar Sustainability Assessment System (which later became the Gulf Sustainability Assessment System and is now the Global Green Sustainability Assessment System, or GSAS).

Significantly, Qatar has hardwired green building into the latest iteration of the Qatar Construction Specifications (QCS), and has mandated achievement of certain sustainability benchmarks in all new government construction projects. Some large development projects have voluntarily incorporated green building technologies, most notable being the Lusail City projects, Qatar Rail (metro), the World Cup 2022 stadiums, the Ashghal projects (schools & mosques), and the new port and navy base.

Qatar has also been making

inroads into developing the residential green building market. In 2012 the Qatar Green Building Council developed the region's first Passive House Experiment, in partnership with Qatar General Electricity & Water Corporation (Kahramaa) and Barwa Real Estate Company, supported by engineers from Texas A&M University at Qatar (TAMUQ). Villa with sustainability features was developed next to a villa utilizing conventional construction features. Two similar families were moved into each villa. The operating expenses and resource construction of each villa were monitored. During the winter, the passive house generated surplus electricity, which was fed back into the electricity grid.

Findings and recommendations

Improvements can be factored into the Nationally Determined Contributions in Qatar's Paris Agreement assessment report.

There are institutional and market-based obstacles towards voluntary adoption of higher standards for residential development projects. Leverage mechanisms and incentives that exist in other markets do not exist (or not to the same extent) in Qatar. In the absence of government mandates, the challenge presented to policymakers is how to create incentives for developers and other stakeholders downstream to incorporate high performance features into residential construction projects.

Solution 1 - Variable Landlord Fee: Since landlords of privately rented accommodations are charged a fee upon the registration of a tenancy agreement, it would be prudent as highlighted above to make the fee variable based upon the proven energy performance of the property. The existence of this fee means that landlords are already required to pay a form of property tax, and are subject to punishment for illegal letting without registration. It is recommended that a property inspection takes place by an authorized Ministerial department, prior to the tenancy registration in order to assess and verify a property's energy performance rating. This official evaluation would be submitted at the time of registration, with premiums charged for less energy efficient properties and discounts for more energy efficient properties. The fees should increase over time for less efficient properties. These measures would go far towards encouraging retrofit by landlords by making it less



Dr. Aaron Richard Harmon

cost effective to rent out low efficiency properties.

Solution 2 - Subsidy reform: This may work more effectively in the short term to ensure costs are a concern when deciding on building design and consumption. The energy performance certificate method adopted by the UK would be possible to replicate for existing buildings and upon property sales, with a requirement for an increasingly high level of performance.

Solution 3: LEED® certification for new buildings would perhaps be the most suitable for Qatar given that they offer a tested, straightforward, achievable, and non-market-based means of rapidly improving new buildings. It is also vital that existing building stocks be upgraded to adapt to similar standards for achieving overall reductions. For new builds, a top-down

mandatory approach would be the most effective approach to ensure total compliance.

Solution 4: Finally, a commitment towards the World Green Building Council's Advancing Net Zero commitment would be advisable to reach best practices.

Achievements

The article was published from researchers at the Centre for Law and Development at the College of Law, Qatar University. The research was conducted and published by Dr. Jon Truby, Associate Professor of Law and Director of the Centre for Law & Development, College of Law, Qatar University, and Dr. Aaron Harmon, Clinical Assistant Professor and Affiliate Researcher, Centre for Law & Development, College of Law, Qatar University. The article was published in the Journal of Sustainable Development.

Rotavirus Epidemiology and Vaccine Effectiveness in Qatar: Ongoing Challenges

Dr. Shilu Mathew

Research Associate, Biomedical Research Center – Qatar University

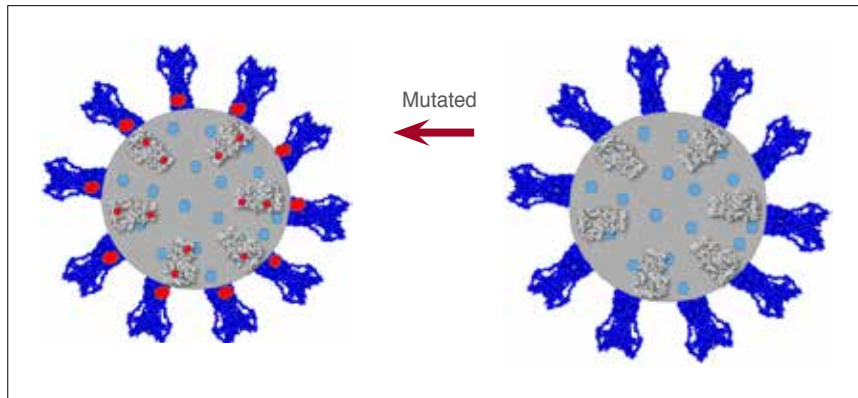

Qatar rotavirus strain (G1P[8])

Rotarix® vaccine strain (G1P[8])



Dr. Shilu Mathew

Rotavirus is a common cause of acute gastroenteritis (AGE) in children worldwide, for which a vaccine is available. The vaccine is provided in Qatar according to the recommendations of the World Health Organization's (WHO) vaccine schedule. In Qatar, Rotavirus vaccine-Rotarix® (GlaxoSmithKline, Brentford, United Kingdom) vaccination is used, which is given at second and fourth month. However, vaccine use and efficacy have not been evaluated in the country.

Dr. Hadi Yassine (Associate Professor of Infectious Disease Unit) from the Biomedical Research Center (BRC), Qatar University (QU) and in collaboration with colleagues Dr. Khalid Al Ansari (Medical Director of HMC's Pediatric Emergency Services) and Dr. Hassan Zaraket (Assistant Professor, American University of Beirut, Lebanon) received an NPRP from QNRF in 2015.

The proposal of the study is to understand the burden of viral gastroenteritis and effectiveness of Rotavirus vaccine in young children in Qatar. In this case, Dr. Yassine and his team member Dr. Shilu Mathew (Research Associate at BRC, QU) evaluated this study in the Qatari community and provide an important addition to this literature with an analysis of Rotarix® vaccine effectiveness and Rotavirus infection among children in Doha, Qatar between 2015 to 2019.

Among the Rotavirus-infected cases, 59.3% had been vaccinated but were still infected. The percentage of reduction of Rotavirus disease in the vaccinated group to the unvaccinated group was only 25%. Interestingly, the common G1P[8] strains constituting the majority of human Rotavirus infection were predominant in most age groups. Comparisons of antigenic domains revealed

80% of G1P [8] strains from Qatar had mutations compared to the G1 and P[8] strains contained in the currently licensed Rotavirus vaccines Rotarix®. 80% (n=8) of the G1 genotype specimens harbored three amino acid substitutions (N94S, S123N, and M217T) in 7-1a and 7-2b antigenic sites in comparison to the Rotarix vaccine. The P[8] strains with G4 and G9 counterparts showed the highest degree of variation among all specimens with known G genotype. These viruses had 15 and 13 substitutions in their VP4 antigenic epitopes when compared with the P[8] component of the Rotarix vaccines.

This study suggests genetic variability in the virus strain to escape the vaccine-derived immune response. It also identified the wide diversity of emerging strains circulating Rotavirus genotypes in Qatar.

Environmental Restoration Solutions: The Mushroom Forest Artificial Reef

Dr. Bruno Welter Giraldes

Research Assistant Professor, Environmental Science Center- Qatar University

The problem:

In the actual Anthropocene epoch, the marine environments are under intense pressure. Presenting overlapped threatened histories, those marine ecosystems have been dropping their biological functionality until a total environmental collapse, with higher intensity in the marine zones close to urban centers. It is an anthropogenic impact that is directly affecting the economy and the wellbeing of the society besides the reduction of fish stock, the collapse of the marine ecosystems, and the destruction of the natural beauty of seascapes and landscapes in coastal areas. That directly affects food security, human wellbeing and tourism in those regions. Indeed, the necessity to improve the fish stock and the beauty of the marine areas around urban centers is a modern problem raised by the society worldwide. It is an environmental problem where the society expects to derive the solution from the scientific community and research centers.

One of the most common solutions presented by scientists and governments for the environmental restoration are artificial reefs. However, a number of artificial reefs have been failing due to



Dr. Bruno Welter Giraldes

several reasons, such as the lack of hydrodynamic or their large sizes that complicates deployment. That results in some being buried by the sediment due to excessive weight or wrong shapes, which increase the retention of sand; and some are just trashes dumped in the water, causing chemical contamination of the environment. In light of what has been said, environmentally friendly artificial reefs that avoid the sedimentation remain absent as an alternative for the restoration of the biological

functionality of threatened marine ecosystems.

Experiments for the development of solutions

Addressing those concerns cited above Dr. Bruno Welter Giraldes as a representative scientist from the Environmental Science Center at Qatar University, decided to work on the scientific development of a new product. The concept was to create innovative applied science for the restoration of the threatened ecosystem in Qatar Marine Zone. Following the modern concepts of scientific development of new products, the new idea started by using the biomimicry concept.

Biomimicry is the imitation of the models, systems, and elements of nature for solving complex human problems, where nature presents technological solutions for engineering problems. In this case, there is need of biomimicry of a natural model with high hydrodynamics, large base to avoid sinking in the sand, with a substrate closer to light for corals and algae growing, and a special material for settlement and growing of good species (coral, oysters, algae etc.) with vertical structures to attract fish shoals. Ideally, a beautiful structure that creates several “houses” for different components of marine biodiversity and at the

same time attracts tourists for underwater activities.

After several comparisons of nature models searching for a shape that achieves the requested aims, the biomimicry of this study was selected. The biomimicry was based on the imitation of the natural coral reef shape of Abrolhos, in Brazil (South America), where corals grow vertically forming columns, which spread out laterally as it gets closer to surface, forming a mushroom shape. A natural coral reef structure with high habitat heterogeneity that is responsible for housing the highest diversity of species among the coastal marine ecosystem in the South Atlantic Ocean.

Another selected biomimicry was based on the material of skeletons of Scleractinia corals, with high porosity, permeability and high bacterial assimilation. It is a natural material with higher settlement rate of the good species (corals, algae, sponge, oyster etc.) and not only barnacles and worm-reefs, the biofouling species commonly recorded in artificial reefs. The concept was designing a special concrete material trying to biomimic the micro-porosities of the corals' skeleton to be used on the top of the mushroom, the ideal area for growing marine species that do photosynthesis. The first concept of the Mushroom Artificial Reefs (Figure 1), is designed with a top made with probiotic concrete material, a vertical column and a large base.

The last biomimicry concept used in this new technology was a nature model that creates a mobility among the structures of the mushrooms. That is because single unities of mushroom might sink in soft sediment or topple in inclined sea bottom.

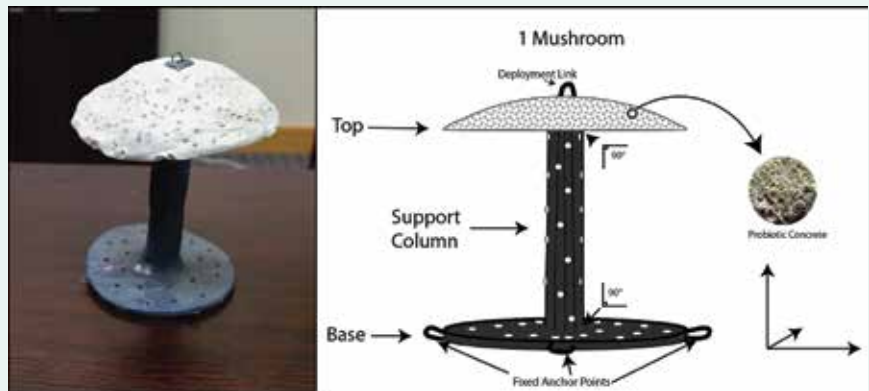

Figure 1. A top made from probiotic concrete, a vertical column and a large base

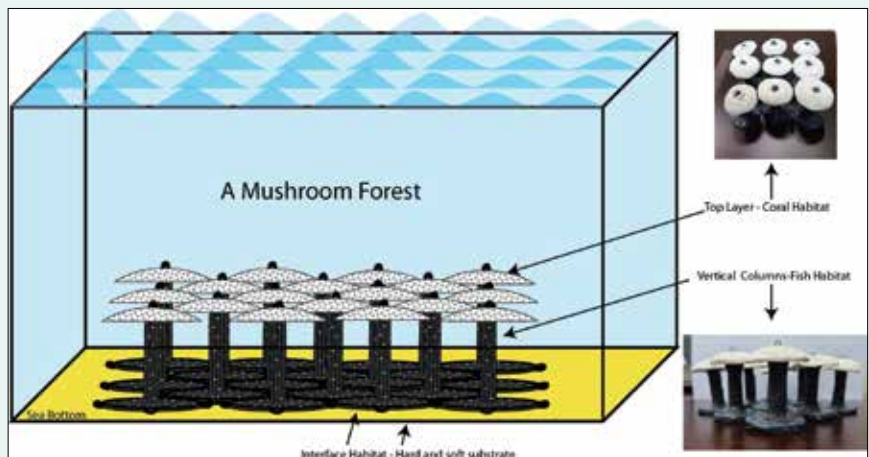

Figure 2. The Mushroom Forest Artificial Reef (MFAR)

The solution was biomimicry of the fluid mosaic model of the cell membrane, connecting the bases of several mushrooms and addressing to the structure a fluid movement accordingly with the sea bottom feature. This large base also supports in reducing the relation weight versus basal area, transforming heavy structures in a fluid mosaic to lay lightly in the sand, fitting in bowed sea feature and avoiding sink in the sand, a solution that also biomimic the Abrolhos reefs, formed by several mushrooms connected. Finally resulting in the shape of the Mushroom Forest Artificial Reef (Figure 2), with several unities connected in the base.

The Mushroom Forest Artificial Reef (MFAR) forms 3 main habitats (Figure 2), (1) The top

layer, (2) the vertical columns and (3) the interface between the base and the soft bottom substrate, totaling important vertical and horizontal habitats, and consequently increasing the habitat heterogeneity (type of houses) and consequently increasing the diversity of species and associated fish stock.

The top layer is made with live artificial rock, aiming to present an ideal substrate for colonial benthic coverage (corals, sponges and algae). Those tops are calcium carbonate enriched and have high porosity coping the coral reef substrate, a microenvironment for the microorganism's balance. The top layer keeps a good hard substrate away from the soft sediment, reducing



First experiments at the University of Queensland in Australia

the deleterious effects of sedimentation over corals (when sands moved by water bury and kill corals). The top layer is bringing a good hard substrate closer to a more illuminated area, allowing increase in the amount of artificial rocks (coral houses) available for the benthic species, highlighting that the great majority of the fish stock in the Qatar Marine Zone is in shallow water associated to benthic ecosystem. In other

words, the top layer of the MFAR will increase the number of available houses because the benthic species will have new good houses to grow in threatened marine zones.

The vertical columns are the habitat for the shoals of small and big fish species. It is well recorded, that vertical habitats observed in shipwrecks are very functional and attract a large amount of fish species worldwide and in Qatar. The Interface Habitat is the main habitat for vagile invertebrates. It is a habitat, recorded with higher diversity of small invertebrates that circulates between the soft substrate and hard substrate; the main food resource for several reef fishes. It forms a biodiversity of Polychaeta, crabs, shrimps and echinoderms, commonly the main food for several fish species.

The entire biomimicry concept allows the scientific description of the new technology and the claim of patent to secure the Intellectual Property Rights. Indeed, the patent of the MFAR was claimed in 2018 and just recently in the late 2019, it was awarded for the Environmental Science Center at Qatar University.

Following the scientific

development steps, after the creation of the concept it is necessary to increase the Technological Readiness Level of the new technology with experiments in laboratory. The research partner in this study Prof. Tom Baldock performed the first experiments in the coastal engineer laboratory in the Queensland University. Scaled prototypes were built and deployed in a layer of soft sediment (sand) in a wave pool and in a flume pool (water current) to evaluate the hydrodynamic, the stability of the structure and the behavior of the sediment around the MFAR. All predicted results speculated in the biomimicry stage occurred successfully. The hydrodynamic shape washed the sediment out and was not covered and the structure remained stable when under strong water currents.

Now in 2020, the artificial reefs in a real scale will be produced by the partner funding company “Smeet Precast and General Contracting Company” and they will be deployed for experiments in a real marine environment. This new technology is being developed here in Qatar and hopefully it will be ready soon for commercial use.



A model for artificial coral reefs



Sustainability Pharmaceutical Policy for Qatar: **A Quick Insight**

Introduction

One of the reasons for extensive regulation of the pharmaceutical sector in most countries is to protect the public. A country's ability to manage the challenges related to public health is greatly dependent on effective and efficient pharmaceutical management and policy.

Pharmaceutical policy deals with the development, supply and use of medicines in the health system. Health systems in developing countries often have difficulty achieving the goals set in their pharmaceutical policies as they neglect cost-effective strategies when managing, distributing and using medicines. It is inexcusable when there is a shortage of essential medicines, irrational use of medicines and

Dr. Mohamed Izham Mohamed Ibrahim
Professor of Social & Administrative
Pharmacy & Head of Research & Graduate
Studies,
College of Pharmacy, QU Health – Qatar
University



Dr. Mohamed Izham Mohamed Ibrahim

money is spent on non-essential, non-cost-effective and low-quality medicines. These actions come at a high cost, waste resources, and fail to prevent morbidity and mortality. A challenge for developing countries is to find effective pharmaceutical strategies that are sustainable. Unless this happens, these countries will continue to face problems with infectious diseases and struggle with the increased economic burden of chronic diseases. Good health and wellness significantly contribute to the economic and social development of a country.

Why pharmaceutical policy?

Pharmaceutical policy ensures access and appropriate use of quality and cost-effective medicines is part of a functioning health system. A good policy will improve availability, affordability, acceptability and rational use of essential medicines through

good governance and effective management practice in the pharmaceutical sector.

What is a sustainable system and sustainability of a healthcare system? A sustainable health and care system is achieved by delivering high quality care and improved public health without exhausting natural resources or causing severe ecological damage. This is slightly broader (but more health care specific) and involves working across the health system and partners to provide health care that deliver on the triple bottom line i.e. simultaneous financial, social and environmental return on investment. It includes adapting how we deliver services, health promotion, more prevention, corporate social responsibility and developing more sustainable models of care.

Why sustainable policy? The main features of a sustainable

policy are to strengthen social capability (i.e. education and technical competence) and human development programs without affecting the future ability of developing and availing resources. A sustainable policy refers to the integration of goals and activities of a policy with sustainable development. It includes incorporating sustainable practices in hospitals and healthcare facilities that are good for the people, and good for the nation.

Pharmaceutical sector scenario in Qatar

Qatar is the world's highest per capita income non-OECD country as well as having the highest per capita health expenditure in the region. The development of the pharmaceutical market is shaped by the decision of the Ministry of Public Health (MoPH) formerly known as Supreme Council of Health (SCH) to abolish government controls over the pricing of medicines and to allow more importing agents and suppliers in the country and has resulted in the adoption of an open market system. The Pharmacy and Drug Control Department (PDCD) manages, implements and regulates pharmaceutical policy, law and practice in the country. Imported medicines account for 97% of the pharmaceutical market. The multinational pharmaceutical companies have been successful in the Qatari market due to people's high brand consciousness for both prescription and OTC (over-the-counter) medicines. There is low interest among multinational manufacturers to set up manufacturing plants in the country due to the small market size. Instead, the country prefers to import medicines primarily from USA, UK or other European countries and others from the MENA and Asian countries.

The domestic drug production is still small and must gradually gain momentum to expand in order to reduce dependence on imported medicines. It will not be sustainable if the present situation continues. The Qatari government favors increasing local production and it promotes the use of generic medicines. There is no policy on generic medicines bioequivalent (it simply means the property wherein two drugs with identical active ingredients or two different dosage forms of the same drug possess similar bioavailability and produce the same effect at the site of physiological activity). The government tends to purchase branded products; however, the share of the generic drug market is increasing. Increased production domestically, coupled with foreign investment and consumption of generics are expected to support the market's evolution. Implementing a pro-generic policy by promoting generic medicines as a substitute and educating physicians, pharmacists and patients about the benefits of generics would be useful. High prices of medicines especially in the private sector are still considered unaffordable for the lowest-income strata. Except for the Qatari public sector, medicine prices, availability, and affordability are falling short from targets. Key policy decisions should be implemented to improve access to medicines. There must be further initiative to ensure availability and affordability of medicines for the general population.

Despite the increased life expectancy of the Qatari population, many people suffer from non-communicable diseases (NCDs) such as diabetes, cancer and heart disease. The pharmacy practice in Qatar has rapidly advanced

in recent years due to a number of national initiatives that have included accreditation programs of healthcare services. To improve efficiency and access and to decrease dependence on hospitals for filling prescriptions, the strategy also promotes a community pharmacy network supported by appropriate policy and processes. Unlike in other countries, there is no independent professional pharmacy association that controls the pharmaceutical practice and represents or promotes the profession of pharmacy in Qatar. Practicing pharmacists felt that the regulatory procedures for the procurement, storage, marketing, and pricing of medications are acceptable and they appeared to be satisfied with the processes associated with dispensing medications in retail settings, public clinics, and public hospital outpatient pharmacies.

In terms of quality of medicines, due to poor management and lack of control, developing countries are exposed to counterfeit, illegitimate and low-quality medicines. Poor-quality medicines either brand or generic are those that do not meet acceptable standards. Thumbs up to Qatar! Studies conducted in Qatar prior to and during the Gulf crisis indicated that the generics as well as the brand product of metformin hydrochloride, a prescription drug used to treat type II diabetes meet the USP requirements and can be considered interchangeable with the chosen innovator brand (Glucophage®). Another study was to run quality control testing for the multisource atorvastatin calcium tablets, an anti-cholesterol agent. The finding indicates that the products successfully achieved in vitro bioequivalence requirements and therefore, can be effectively prescribed interchangeably

with the branded reference of atorvastatin (i.e Lipitor®).

A situational analysis was conducted to assess the pharmacovigilance system in the country. The findings indicated that the overall performance of the country needs to be improved following a system-based approach. It is recommended to: improve PV prioritization in the regulatory, practice and academic agendas; establish effective PV structures, especially PV specific legislation and PV center; target efforts to improve and coordinate PV between national stakeholders; and build the national PV system capacity to meet the minimum requirements of WHO.

What is next?

Qatar desires to manage and develop an integrated healthcare system according to world-class standards in order to improve the health of Qatar's population. Achieving Sustainable Development Goal – Good Health and Well-being, should be a major global goal for the Qatar pharmaceutical sector. A sustainable pharmaceutical sector will continue to provide high value to public health, and at the same time save resources for future Qatari generations. To ensure sustainable access to medicines, the pharmaceutical sector needs to be strategic, which can only be achieved with responsible and effective pharmacy leaders. To ensure that Qatar has a quality pharmaceutical system, that is accessible and affordable; reformation is needed to get the maximum return for every Qatari riyal spent. It needs a quality and effective pharmaceutical policy in place. The government must establish the National Medicine Security Strategy as part of a sustainable pharmaceutical policy initiative.

Resin Bonded Bridges in Patients with Hypodontia: Clinical Performance Over a 7-year Observation Period

Dr. Lamyia Anweigi,

Assistant Professor of Prosthodontics, College of Dental Medicine-Qatar University

With my area of research, being the Clinical evaluation of the treatment provided to patients with congenital missing teeth (Hypodontia), and to assess their quality of life using mixed methods (qualitative and quantitative research).

The first academic staff appointed at the first Dental school in Qatar, College of Dental Medicine, I am honored to represent Qatar University's first affiliation from the College of Dental Medicine.

Hypodontia or congenitally missing teeth (CMT) is a condition where one or more teeth are developmentally absent and may be present with varying degrees of severity. Hypodontia is associated with characteristic morphological changes in the teeth, alveolar volume deficiencies, and skeletal jaw mal-relationships. Management may be complex, involving several dental specialties, ideally working as a close-knit team. Improved diagnostic and treatment technologies continue to evolve, ever widening the management opportunities for these patients. Hypodontia, is costly dental anomaly. The management options for patients with Hypodontia range from no treatment and accepting the space, to orthodontically



Dr. Lamyia Anweigi

closing, or opening the space and maintaining or redistributing spaces for replacement. The management is influenced by the patient's choice, age and expectations. Other factors are the type of occlusion, level of malocclusion, aesthetic requirements, the presence of any soft tissue defects, and the psychological status of the patient.

The treatment of patients with congenitally missing teeth or Hypodontia requires a multidisciplinary team approach to provide the best functional,

phonetic and aesthetic outcome. Resin bonded bridges (RBBs) are considered a conservative option in the management of Hypodontia. The data related to RBB survival that have been previously reported may not accurately reflect the situation in patients with Hypodontia.

The current study is "Resin bonded bridges in patients with Hypodontia: Clinical performance over a 7-year observation period." This study aims to analyze the survival of resin-bonded bridges provided to patients with Hypodontia at the Department of Restorative Dentistry, University Dental School and Hospital Cork, Ireland. It was also to determine the factors that may influence the survival of RBBs in patients with Hypodontia. The study protocol was reviewed and approved by the Clinical Research Ethics Committee of the Cork Teaching Hospitals, Republic of Ireland. Patients with congenitally missing teeth who received resin-bonded bridges were contacted and invited to participate in the study. A full clinical information and examination was carried out and the data recorded. The patients' were satisfied with the overall treatment using Analogue Scale (VAS).

Importance and main findings of the study:

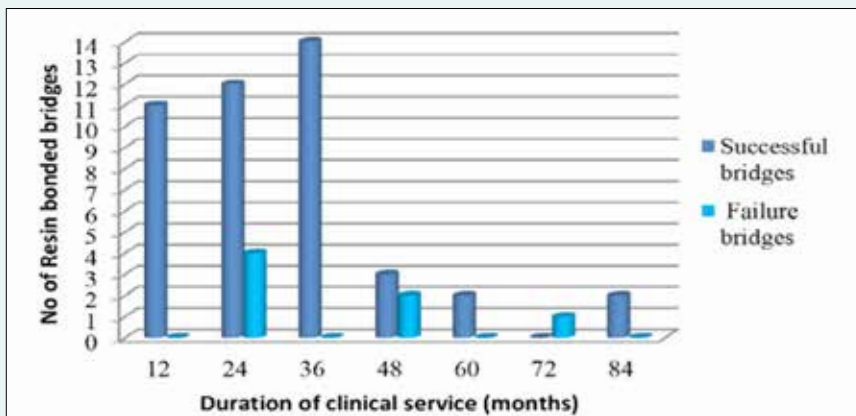

Figure 1. The length of clinical service of the

The success rate in the current study was 86% (Figure 1).

The age and gender, location, occlusal factors and para functional activity have no influence on the survival of resin-bonded bridges in the current study. Orthodontic tooth movement is prone to relapse, adversely affecting resin-bonded bridge survival. It recommended extending the orthodontic retention period after orthodontic treatment for space retention

stability. Post-orthodontic retention is hugely beneficial since it prevents relapse of the abutment teeth. Rubber dam use during the bonding procedure has a detrimental effect on performance. Success seems to increase if tooth preparation was per-formed as surface area for retention is increased. Generally, there was a high level of satisfaction with resin-bonded bridges (Table 1).

This study also considered resin-

bonded bridges as an adequate treatment option for replacing congenitally missing teeth.

In conclusion, a resin-bonded bridgework provides a reliable and minimally invasive solution for replacing missing teeth in young patients with Hypodontia. A higher percentage of patients with Hypodontia expressed satisfaction with resin-bonded bridges.

The article is available on:

<https://www.sciencedirect.com/science/article/pii/S101390521930481X>

illustrative pictures:



Congenitally missing lateral incisors.



Ridge preparation at the pontic site; the central incisors and canines built up using composite resin to improve dimensions.



Resin-bonded bridges in-situ replacing the lateral incisors.

Person who insertd bridge				
Length of the clinical service for successful bridges (months)	Staff	Undergraduate students	Postgraduate students	Total
12	2	9	0	11
24	5	7	0	12
36	2	10	2	14
48	0	3	0	3
60	0	0	2	2
84	0	2	0	2
Total	9	31	4	44
Length of the clinical service for failed bridges (months)	Staff	Undergraduate students	Postgraduate students	Total
24	3	1	0	4
48	0	2	0	2
72	0	1	0	1
Total	0	4	0	7

Table 1. Operator experience and resin-bonded bridge survival



Our Role towards Creating a Sustainable Mobility Culture in Qatar: **The Case for Electric Cars**

Dr. Nuri Onat
Research Assistant
Professor, Qatar
Transportation and Traffic
Safety Center,
College of Engineering –
Qatar University

The development of “Smart, Environmental Friendly, and Integrated Transport” has been a major challenge in the world. Many countries are investing in future transportation technologies including autonomous (driverless), alternative fuel options such as electric cars, and more efficient mobility services such as shared mobility. Achieving a sustainable transportation culture requires cutting-edge education practices and public awareness about the impacts of people’s choice of transportation mode. As individuals, our preferences and the way we live puts a burden on others’ and future generations’ shoulders such as climate change, human health

impacts stemming from harmful air pollutant emissions. In this regard, the role of universities is crucially important due to their major role in transforming the society they exist in. For example, universities around the world have been developing their sustainability programs to achieve a sustainability culture, allowing future generations to raise awareness and becoming future game-changers. Considering that, Qatar University (QU) is the nation's largest and the most prominent institution with a high number of young residents. QU plays a pivotal role in transforming the Qatari society towards achieving a sustainable transportation culture in Qatar. In this regard, our center, Qatar Transportation and Traffic Safety Center (QTTSC) in conjunction with the College of Engineering, is working on multiple research projects about the future of mobility in Qatar. For instance, a pilot demonstration project for electric vehicles is developed to serve the University's role in transforming the society towards sustainable practices in Transportation. This project aims to create awareness about the environmental impacts of transportation in Qatar University campus and to reveal potential benefits of offering alternative transportation modes and technologies (electric cars and electric busses), towards achieving green transportation in the QU campus. Research shows that electric cars are useful alternatives in terms of reducing greenhouse gas emissions and air pollution in cities. On the other hand, it is also important to note that the benefits of electric vehicles highly depend on local (regional) characteristics such as how we are generating electricity, how the climate conditions and its influence on fuel consumption



Dr. Nuri Onat

in cars are, and how the driving behavior is. These factors will determine the potential benefits we can get from the adoption of electric cars. Our preliminary research shows that electric cars can significantly be helpful for reducing air pollution and can relatively reduce the greenhouse gas emissions contributing to the global climate change.

The demonstration project, first, proposes to establish a pilot demonstration in the Qatar University campus by introducing electric sedan vehicles (two Nissan Leafs), electric busses, and solar-powered charging stations to serve the students an alternative transportation option within the campus. Initially, two sedan electric cars will serve as shuttle service from/to the Qatar University Metro Station. This will increase the awareness within the campus and will pave the way for wider applications through research and dissemination activities. The project will bring together talent and expertise from the automotive industry, government, and academia. A consortium including Qatar

University and Marubeni Corporation (the funder of the project), are realizing the electric vehicle demonstration project within multiple phases.

Some of the major obstacles towards the widespread adoption of electric vehicles are the high cost of development and parts, including batteries, electric motors, and supporting infrastructure. Furthermore, the efficiency of electric motors and batteries under harsh weather conditions (extreme heat) requires further research and tests. From a research perspective, the researchers from QTTSC will investigate these aspects and produce technical reports and publications focusing on these issues. In addition, the research team from Qatar University will analyze the potential socio-economic (life cycle cost, human health, etc.) and environmental benefits (reduction in carbon emissions, air pollution, energy use, and efficiency, etc.) of electric cars. Revealing the real benefits of the project will support a mind-shift and perception of electrified transportation in the general public, increase the potential to receive more incentives/ support from local and national authorities, and open up new investment opportunities on a wider scale. The quantification of the socio-economic and environmental impacts of the demo will produce scalable findings and provide a macro-level assessment at a national scale in addition to a micro-level assessment of the demo. For example, in further phases, wider applications, such as the use of electric busses in World Cup 2022, and beyond. These research efforts at QTTSC align with the Qatar National Vision 2030 for social, economic, and environmental development.

Control of Heart Diseases: Cardiac Rehabilitation Program

Dr. Karam Turk-Adawi

Assistant Professor of Public Health, College of Health Sciences – Qatar University



Dr. Karam Turk-Adawi

The current study “Cardiac Rehabilitation Availability and Density around the Globe” stemmed from the Global Cardiac Rehabilitation (CR) Program Survey undertaken by the International Council of Cardiovascular Prevention and Rehabilitation (ICCPR), in response to calls by international organizations including the World Health Organization (WHO), for implementation of preventive strategies to reduce the growing burden of cardiovascular disease. The protocol of the study was endorsed by several international organizations, including the World Heart Federation. The Global CR Program Survey took place over 3 years with a global collaborative team of 60 investigators and other collaborators. From Qatar

University, Dr. Karam Turk-Adawi, Assistant Professor of Public Health/Qatar University, has been an active collaborator in this global initiative (<http://globalcardiacrehab.com/global-cr-program-survey/>). The findings of this global study were covered extensively by international and local media, as well as featured in a commentary by experts in the *EClinicalMedicine/Lancet*.

It is well documented that cardiovascular diseases (CVDs) are among the leading burdens of death and disability globally. In 2015, there were 423 million CVD cases around the world. This number is expected to increase dramatically in the absence of effective interventions. Clearly, there is great need for

secondary prevention strategies to mitigate the reduced quality and quantity of life in patients with CVDs. Cardiac rehabilitation (CR) is a chronic disease management model of care delivering secondary prevention in a cost-effective manner. It is shown that participation in CR reduces cardiovascular morbidity and mortality by 20%, and significantly reduces risk factors, improves health-related quality of life, and promotes a healthy lifestyle. However, CR is underutilized globally; almost 50% of patients diagnosed with CVD do not enroll in this beneficial program. There is an association between availability of programs and utilization. Previous literature suggests that 60% of the countries worldwide do not have CR programs, but there has been no primary study, which could ascertain the countries where CR exists (i.e. availability).

This study is aimed to establish CR availability, capacity and density. As applicable, these were described country wise, World Health Organization regions, and globally. For data collection, 203 countries were considered; an extensive strategy was used, outlined in the article, to identify countries with CR and programs within countries. National and international CR and cardiology societies were also contacted to solicit collaboration. Data from the

Global Burden of Disease Study were used to estimate the number of patients who would be eligible for CR in a given year (i.e., need).

Importance and main findings of the study:

This is the first-ever cardiac rehabilitation audit and survey quantifying the capacity of cardiac rehabilitation services in relation to the need in every country for patients with heart diseases.

The study revealed that cardiac rehab was available in only half (54.7%) of the 203 countries of the world. Across the WHO regions, CR availability was highest in Europe, with 80.7% of the countries, and lowest in Africa with 17.0% of the countries, where CVD mortality is expected to witness the highest increase among WHO regions in the next decade. The Eastern Mediterranean Region (EMR) showed a trend similar to that of the globe, with 54.5% countries implementing CR, while the region is anticipated to witness the second greatest increase in CVD mortality in the next decade. Availability of CR programs was reported country wise. Noticeably, CR is often non-existent in countries with the most pressing

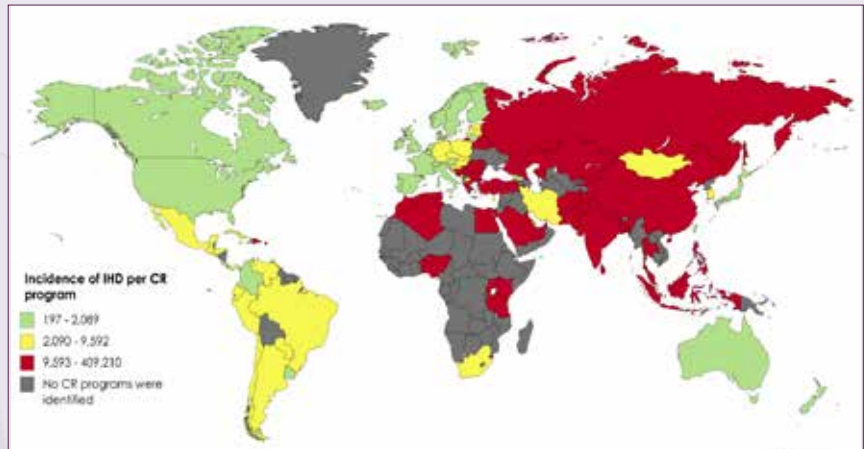

Figure 1. Ischemic heart disease incidence by number of cardiac rehabilitation programs in a country

need, where there is high incidence of ischemic heart disease (IHD) and low resources. For example, Ukraine does not have any program while it has the highest estimated IHD incidence with more than 0.5 million cases annually (Figure 1).

The striking finding is that only one in 12 heart attack victims globally can receive rehabilitation to prevent another event, and programs that do exist can only serve 1.65 million patients each year. This means that over 18 million patients in need for CR will be left out of this life-saving program. In the Eastern Mediterranean Region, approximately 2.1 million more

rehab spots are needed every year to treat patients newly diagnosed with heart disease.

In Qatar, there is only one cardiac rehab program; therefore, we have only one spot for every 37 heart patients that need it. There is a need to expand cardiac rehabilitation services to treat 6,811 more patients every year.

The reason for insufficient CR spots could be attributed to lack of financial resources, which was the most reported barrier to greater CR delivery, followed by lack of patient referral.

In conclusion, the current CR availability and capacity cannot meet the global service needs. Advocacy for greater implementation and capacity is needed. Offering alternative and affordable models such as home-based and community-based programs, proven as effective as outpatient CR program, could increase the capacity of existing CR programs, especially in low and middle-income countries. Additionally, governments should support public funding and use of technology to increase the number of patients each program can treat.

The article is available at: [https://www.thelancet.com/journals/eclinm/article/PIIS2589-5370\(19\)30100-2/fulltext](https://www.thelancet.com/journals/eclinm/article/PIIS2589-5370(19)30100-2/fulltext).



Cardiac Rehabilitation Program in Heart Hospital in Qatar

Water Control in Oil and Gas Wells: Novel Polymeric Gels

Dr. Ibelwaleed Ali Hussein

Research Professor, College of Engineering, Qatar University



Dr. Ibelwaleed Ali Hussein

Introduction

High water production is one of the main challenges in the oil and gas industry. On average, three barrels of water are produced with each barrel of oil daily worldwide which in cumulative comprise more than 300 million barrels of water per day. Accordingly, this huge amount of water escalates the treatment of cost at surface facilities resulting in spending of 40 billion USD annually by oil companies to treat the produced water from oil and gas wells. Therefore, excess water production raises oil production expenses because of the additional load on surface facilities to handle the produced water. Furthermore, unwanted produced water decreases oil production, causes corrosion of tubings and equipment and causes scale development which interrupts production from oil and gas.

Causes of high water cut

High oil well production rates especially when pumps are used can eventually end up with increasing water production with time because water bypasses oil in the formation. Wettability alteration from water-wet to oil-wet after downhole chemical treatments makes the water phase free to move in the porous media which alters the mobility conditions and hence increases water production. Leakage of water behind the casing or tubing

because of cement failure and tubular corrosion or erosion is another possible source of excess water. Figure 1 illustrates examples of near-wellbore water sources.

Moreover, reservoir formations are heterogeneous with high contrast in permeability and complex network of fracture systems. Heterogeneity of sandstone and carbonate reservoirs complicates the water production issues since water tends to move inside the matrix/fracture system which hinders the efficiency of near-wellbore shut-off techniques. Figure 2 reveals reservoir formations featured with natural fractures and high permeability zones.

Water control methods

Conventional treatment of water control involves remedial squeezing of cement. However, cementing operations take long durations for the cement to harden. Add to that, cementing is efficient to plug near-wellbore water zones and cannot be applied for in-depth control. Mechanical methods such as packers and bridge plugs are

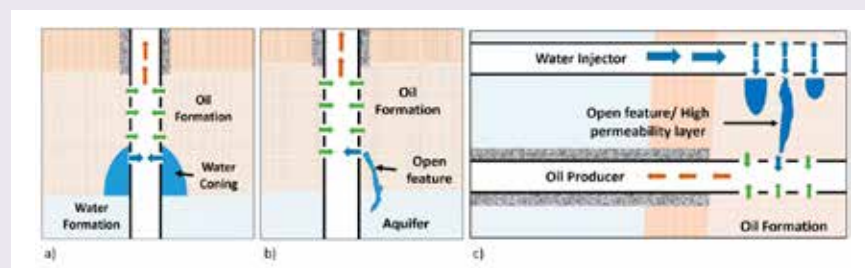

Figure 1. Examples of excess water sources: a) water coning due to high production rate, b) open fracture, and c) water channeling due to cement failure (Taha & Amani, 2019).

installed inside the wellbore to seal off the water zones near the wellbore. Smart completion techniques such as inflow control valve (ICV) have been recently used to control water flow. Nevertheless, the high cost of smart mechanical valves, as well as long waiting time for cement hardening, restrain the applicability of such systems for near-wellbore water shut-off. Moreover, in some cases such as wettability alteration of the porous media and profile changing; in-depth water control is more effective. Chemical formulations such as polymeric solutions and emulsions reveal high competency in sealing water shut-off zones. Thus, crosslinked polymers are useful for in-depth water control in heterogeneous formations such as naturally fractured reservoirs, vuggy carbonate zones and highly contrasted permeability sandstones.

Among the many types of polymers/crosslinkers systems that have been applied in water control; polyacrylamides are the most used type of polymers because of their preferred properties as well as a reasonable cost for field applications. Based on the type of crosslinker used to develop the gel, crosslinked polymers can be classified into organic and inorganic. The common types of organic crosslinkers are polyethyleneimine (PEI) and chitosan, whereas, inorganic crosslinkers include chromium, zirconium and aluminum. Organic crosslinkers are preferred for high-temperature applications (> 90°C) while the inorganic crosslinkers are suitable for low-temperature ranges (El-karsani et al., 2014; SPE-163100-PA). Moreover, the crosslinking mechanism of organic and inorganic crosslinkers with PAM is different. High gel strength can be obtained by crosslinking PAM with organic or inorganic

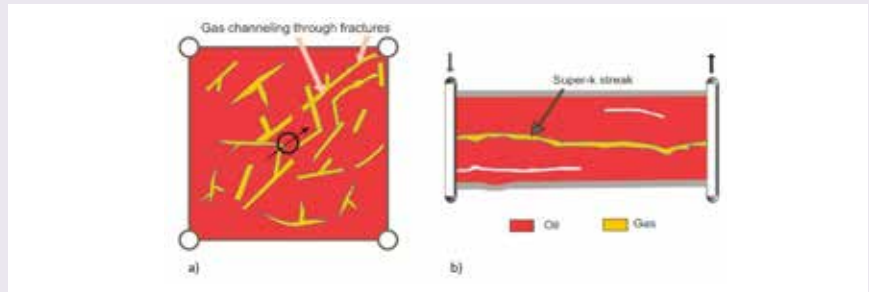

Figure 2. Heterogeneous reservoir formations: a) naturally fractured, and b) high permeability streak

crosslinkers. However, the produced gel can be further reinforced by using additives such as nanosilica to deal with some cases such as sealing fractures. The use of different sizes of nanosilica provides more strength to the gel as well as thermal stability without any side effects on the gelation kinetics.

Advancement in the research shows the development of micro-gels and emulsified gels to modify the relative permeability of the formation and hence change the rock surface to water-wet favorable conditions. The main advantage of such types is their ability to penetrate deep in the reservoir, thus, control the water cut in the early stage. Moreover, emulsified gels allow selective plugging of water phase without affecting oil production under controllable gelation time. Organoclay has been introduced recently (USPO#9,951,593, 2018) as low cost and environmentally friendly emulsifier with polymeric gels. It has a high surface area, controllable separation time depending on composition, ability to withstand high salinity, which is about 5 times the salinity of Gulf seawater, and high temperatures (120°C).

The research group of Prof. Ibelwaleed Hussein has about 15 years of experience in developing polymeric crosslinked formulations for conformance control applications in oil and gas reservoirs. Novel polymeric solutions, which are economically

and technically competitive to conventional formulations, have been patented and registered at the United States patent office (USPO#9,951,593, 2018; USPO#10,351,756, 2019 & USPO#62/880,845, 2019). These developed novel polymeric gels have been successfully applied in the Gulf fields to mitigate water production (Al-Muntasheri et al., 2010; SPE 129848).

Recently, the research group of Prof. Hussein at the Gas Processing Center at Qatar University in collaboration with Oklahoma University has successfully developed reinforced polymeric gel for conformance control applications at high reservoir temperature (130°C) which are suitable for Qatari gas reservoirs.

This project is supported by Qatar National Research Fund (QNRF) under National Priorities Research Program (NPRP) (project NO. 10-0125-170240). A patent application has been requested in US patent office (USPO#62/880,845, 2019). Moreover, a local company has shown interest in commercializing these products for the oil and gas sector in Qatar, which aligns with QP Tawteen program.

References

Taha, A., & Amani, M. (2019). Overview of Water Shutoff Operations in Oil and Gas Wells; Chemical and Mechanical Solutions. *ChemEngineering*, 3(2), 51. <https://doi.org/10.3390/chemengineering3020051>

Smart Solutions for Sustainable Seawater Desalination:

Nanoscience-based Electrochemical Technologies

Dr. Aboubakr Moustafa Abdullah

Research Associate Professor, Center for Advanced Materials - Qatar University



Dr. Aboubakr Moustafa Abdullah

Water is the essential natural resource on planet earth for all human activities, ranging from health to energy production. However, ensuring reliable access to clean water is the most significant global

challenge of this century, owing to the continual growth in the world's population, economic development, and global climate change, which all are a surge of threats that could exacerbate water scarcity globally.

This is because only 0.014 % of the water on earth is fresh and accessible, whereas 97 % is saline, and the rest is inaccessible. Alarming, more than 884 million people have no access to clean water, and 1.8 million children die every year because of water problems. The United Nations reported that, in 2030, water resources would not be adequate to meet 60 % of the world's need. Seawater desalination is amongst the practical roadmaps for human needs. As a paradigm, Qatar and Gulf countries (GCCs) are getting more than 90% of their potable water from seawater desalination processes. Thus they will direct more than 80 % of their oil and gas income for the water desalination in the coming 20 years. Reverse osmosis (RO), nanofiltration (NF), and thermal multi-stage distillation (MSF) are the currently-used water desalination technologies. However, its complex operation, significant-energy consumption, high cost, membrane fouling, and inevitable pollution block their utilization in sustainable future societies. Unlike the aforementioned ones, the capacitive deionization (CDI)

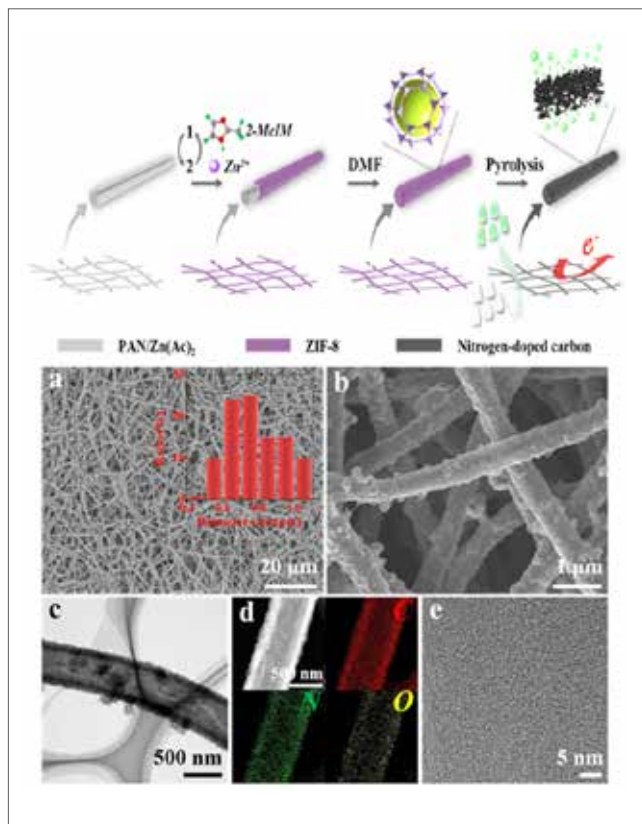

Figure 1. Schematic shows the fabrication process of MOF-derived NCTs. (a, b) field-emission scanning electron microscopy, (c) TEM, (d) EDS elemental mapping, and (e) HRTEM images for NCTs. The inset of (a) is the diameter size distribution of NCTs.¹

is a highly efficient, scalable, environmentally-benign, and cost-effective desalination technique. It works at room temperature and an applied voltage < 1.8 V. The CDI process is driven by the electrical double layer, where Na^+ and Cl^- ions are adsorbed on the cathode and anode, respectively. Various porous carbon-based materials such as activated carbon, graphene, and metal-organic framework, are the most active electrodes for the CDI, due to their great surface area and stability, but their complicated manufacturing process, inferior capacitance effect, and low specific surface area preclude their utilization over seawater. Accordingly, novel electrode materials with a great salt adsorption capacity,

lower electrical resistivity, and efficient ion storage capability, are an urgent need for CDI seawater. Nanoscience could overshoot these fences and offer leapfrogging avenues in sustainable CDI. Regardless of the origin of the term "Nano" which means "dwarf" in the old Greek, nanoscience bridges the past, present, and future. Ancient Egyptians used nanotechnology in cosmetics and mummies' disinfection. Also, they used modified clays for water purification and preservation. On the other side, Romans used it for ornamentation purposes. Nanotechnology has been employed in multi-functional processes to enable simultaneous multi-tasks, e.g., water disinfection, purification,

and desalination.

Recently, in 2020, we have developed novel porous spatial interconnected metal-organic framework (MOF) derived nitrogen-doped porous carbon tubes (denoted as NCTs) as efficient nanoelectrodes for the CDI process.¹ This MOF is prepared by the electrospinning of polyacrylonitrile (PAN) / Zinc acetate ($\text{Zn}(\text{Ac})_2$) into one-dimensional nanofibers, and by using them as a template for the controlled growth of basolite Z1200 (ZIF-8) nanocrystals. Later, we can selectively dissolve the template and follow this step by two consecutive annealing ones under the nitrogen atmosphere (Figure 1). The field-emission scanning electron microscopy (FESEM) image showed the

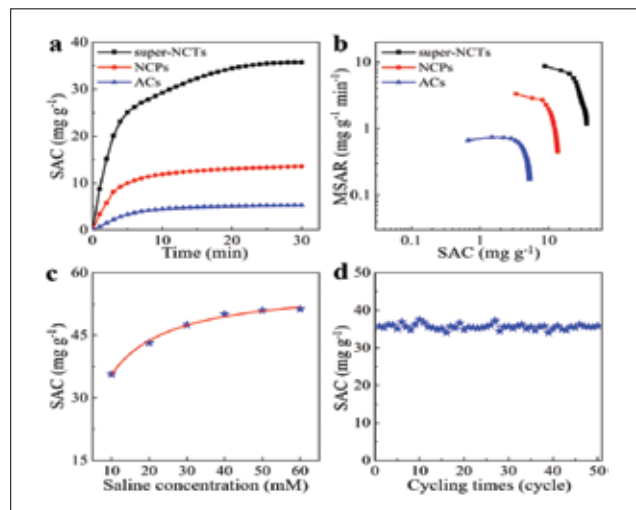

Figure 2. (a) SAC variations and (b) CDI Ragone plots of NCTs, NCPs, and ACs, (c) SAC value vs. saline concentration and (d) cycling desalination performance of NCTs.¹

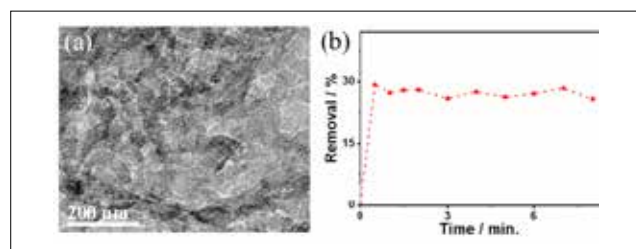

Figure 3. (a) TEM image of N-CN-M nanostructured electrode and (b) its CDI performance for removal of NaCl from seawater versus time

formation of well-defined one-dimensional NCTs assembled in a three-dimensional continuous network-like structure composed of interconnected carbon tubes with an average diameter of 700 nm (Figure 1a-b). The Transmission electron microscopy (TEM) image showed that the as-formed one-dimensional NCTs have porous nanotube structures (Figure 1c). The Energy-dispersive X-ray spectrometry (EDS) element mapping analysis revealed the homogenous distribution of C, N, and O inside and outside the nanotubes (Figure 1D). The High-resolution TEM (HRTEM) displayed the amorphous carbon microstructure (Figure 1e).

The CDI performance of the as-obtained porous one-dimensional NCTs was tested in an aqueous solution of NaCl (10 mM) under an applied voltage of 1.2 V relative to N-doped carbon particles (denoted as NCPs) and commercially activated carbons (denoted as ACs) (Figure 2). Interestingly enough, the salt adsorption capacity (SAC) of typically prepared porous one-dimensional NCTs (35.7 mg g^{-1}) was significantly higher than that of NCPs (14.5 mg g^{-1}) and ACs (5.5), by more than 2.4 and 6.4 times, respectively (Figure 2a). This is owing to the porous one-dimensional structure and the greater surface area of the porous one-dimensional NCTs ($1323.5 \text{ m}^2 \text{ g}^{-1}$), compared to the NCPs ($735.5 \text{ m}^2 \text{ g}^{-1}$) as well as the presence of multiple pores. Meanwhile, the mean salt adsorption rate (MSAR) and SAC of the one-dimensional NCTs were also significantly higher than that of the NCPs and ACs, as shown by the upper-shift and more-right area in the CDI Ragone plots of (Figure 2b). Additionally, the porous one-dimensional NCTs showed

a great CDI performance in different concentrations of NaCl solutions ranging from 10 mM to 60 mM (Figure 2c).

The simulated CDI performance made by the Langmuir isotherm model along with the experiment of CDI measured in 10 mM NaCl on porous one-dimensional NCTs exhibited the efficient cycling stability with insignificant capacity fading (Figure 2d). These results displayed excellent lifetime and viability of porous one-dimensional NCTs for practical application. Intriguingly enough, the obtained CDI performance of porous one-dimensional NCTs was superior to the previously reported carbon-based electrodes, including MOF-derived carbons, carbon nanotubes, graphene, mesostructured carbons, carbon spheres, and ACs under the same reaction conditions because of its porous one-dimensional nanotube structure with a great surface area that makes it more accessible for the ion adsorption and reduces the diffusion distance for the ions.

In 2020, we provided a groundbreaking research based on "atomic-doping" for transcending the activity, stability, surface area, conductivity, and active sites shortcomings.² This substantial concept is not only beyond the nanoscience but also endow the performance of existing materials as well as promoting the development of new materials and processes. In particular, we used a one-pot polymerization method followed by a carbonization step under a nitrogen atmosphere to synthesize atomically-doped nitrogen-enriched carbonaceous multi-dimensional nanostructures (denoted as N-CNs-M). Distinct from the

traditionally carbonaceous materials, our newly developed material possesses multi-dimensional nanostructures with meso-, micro-, and macropores (Figure 3a), with controllable, accessible surface area and tunable atomic dopants of any metal and/or non-metal atoms. This is along with the outstanding electrical conductivity, impressive photo-properties, enriched electron density, abundant active sites, and prompt diffusion rate. Intriguingly enough, for the first time in the world, the as-developed N-CNs-M nanostructures were used as active and durable electrodes for the CDI of seawater instead of brackish water as elsewhere, typical for a CDI process. Our results displayed and showed the successful removal of nearly 30 % of NaCl from the seawater within only 30 sec, under an applied voltage of 1 V, at room temperature, and in one-step without using any commercial additives (Figure 3b). As our N-CNs-M material is photoactive, the solar light was found to enhance the CDI performance of N-CNs-M electrodes by at least 1.5 times. Additionally, our concept is viable for numerous naturally abundant and inexpensive carbon-based precursors that can easily allow the scalable use of CDI for seawater desalination in the coming ages for a sustainable future.

References

1. Xu, X., Yang, T., Zhang, Q., Xia, W., Ding, Z., Eid, K., Abdullah, A. M., Hossain, M. S. A., Zhang, S & Tang, J (2020). Chemical Engineering Journal, 124493.
2. Kamel, E., Mostafa, H. S., & Aboubakr, M. A (2020). US Patent, 16/745,533.



QU College of Law Organizes Annual Conference 2020 on the Topic ‘Law and Media’

Organizer: College of Law, sponsored by Dr. Thani Bin Ali Al-Thani Law Firm

Date: 27-28 January 2020

Venue: Ibn Khaldoon Hall - Qatar University

The College of Law at Qatar University has always taken the approach of an active contributor

in submitting proposals and opinions to improve and develop laws and legislative systems in the country according to the community needs. The College of Law chose the topic, “Law and Media” for its 2020, International Conference with the participation of College professors and scholars from law colleges worldwide. Office of Dr. Sheikh Thani Bin Ali Al Thani Law Firm sponsored the Conference.

The relationship between media and law is a strong one based on the principle of complementarity and mutual influence, as the media plays a leading role in promoting justice, raising



Dr. Muna Al Marzouqi, Associate Dean for Research & Graduate Studies at College of Law honors participants in the 'Law and Media Conference'

awareness of public rights and duties, addressing issues affecting the community's safety and security, and enhancing the principle of dialogue.

Given the need to research the dimensions of the legal organization of media activities in general, this conference was held to:

Shed light on the legal foundations that govern legal activities, and the challenges facing the traditional and modern media sector represented in social media and address them legally.

Focus on the media developments that occur due to the technological revolution and dealing with them legally.

Provide a fertile ground for constructive discussion, purposeful and insightful research, exchange of ideas and experiences in various legal and media issues to limit any negative impacts that may occur to the society.

Conference Recommendations:

Study the need to develop special criminal legislation to encounter misinformation.

Legislator is advised to follow the same approach adopted in strengthening media freedom when drafting changes in the new media law.

Amendment of the Qatari Consumer Protection Law No. 8 of 2008 by adding a text stating



Dr. Shaker Mezoughi, Professor of Civil Law at College of Law – Qatar University

that the advertiser is primarily responsible for the crime of false advertising even if the advertiser is a moral person.

There is a need to issue an integrated law as a substitute for Law No. 1 of 2012 on the Regulation and Control of the Placement of Advertising and focus on the substance of the ads.

Consider the French experience and study the extent of its application in Qatar in terms of the financial penalty that the advertiser who commits a harmful act, has to pay if there is no contract between the advertiser and the consumer.

Study the possibility of adding a legal text stating that the responsibility of the advertiser and the advertising agency is based on the assumed error.

Considering recent legislative experiences in the field of copyright across digital media platforms such as the European Directive No. 790 of 2019 on copyright and related rights.

The necessity of establishing specialized bodies to combat violation of electronic publishing rights over the internet in a manner that does not violate basic rights and freedoms.

Study the need to establish a judiciary system specialized in media and press issues.

Include journalism and media crimes in the respective curricula.

Emphasizing the importance of Arab regional and international cooperation in the field of combating cross-border crimes of modern means of communication, and the need for closer cooperation in research and investigation phases and control of evidence to counter this criminal phenomenon.

Qatar University's Graduate Studies Office Welcomes Students on the Orientation Day for Spring 2020 Semester



Ghada Al-Kuwari, Assistant Dean for Student Affairs at Graduate Studies Office in the Orientation Day for the newly admitted graduate students, Spring 2020

Organizer: Graduate Studies Office

Date: 11 January 2020

Venue: Research Complex - Qatar University

On Saturday, January 11, 2020, the Graduate Studies Office under the Office of Vice President for Research and Graduate Studies at Qatar University conducted an Orientation Day for the newly admitted graduate students, for Spring 2020 in the Research Complex (H10). The event saw the presence of different college representatives; welcoming 70 newly admitted students into the program.

The event started with a welcome speech from the Dean of Graduate Studies, Dr. Ahmed Elzatahry. He spoke about the nature of the study during the postgraduate stage while comparing it with the undergraduate stage of learning. There was a quick presentation introducing the Office of Graduate Studies and its different departments, and the

type of services that it provides to students.

The members of the Student Affairs team of the Office also presented a brief summary of the nature of their work and the services that they provide to graduate students. Ms. Ghada Al-Kuwari, Assistant Dean for Student Affairs at the Office of Graduate Studies, made a presentation that included a guide to the website of the Postgraduate Office available on the official Qatar University website, followed by a detailed explanation of some important policies that students must

consider during their studies at the University. She also drew the students' attention to the services provided by the Student Services Department such as copying, printing, providing the University ID cards, as well as an overview of how to obtain textbooks in both paper and electronic forms. In addition, students were briefed about the Institutional Review Board (IRB), which deals with research ethics, and the types of approvals that must be obtained by students before starting their thesis. The event also included a captivating speech by Ms. Mounia Zidani, Senior Graduate Writing Specialist where she spoke about the services provided, such as workshops for writing a university thesis, how to use the SPSS program and benefit from it in research questionnaires. She also spoke about tadTalks and tad Bootcamp events organized by the Learning Support Unit, which are conducted regularly under her supervision. The event concluded with a discussion session, during which all student queries were answered by the Dean and Assistant Deans of the Postgraduate Studies Office.



Newly admitted GS registering for the Orientation Day - Spring 2020

tad Boot Camp 2020



Engineering GS at tad Bootcamp 2020

Organizer: Graduate Studies Office

Date: 27-29 January 2020

Venue: Research Complex - Qatar University

The tad Boot Camp is organized by Learning Support in the Office of Graduate Studies under the Vice President for Research and Graduate Studies. The third annual tad Boot Camp was held on January 27-29th, 2020 in the Research Complex at Qatar University. The boot camp is part of the tadMatters™ brand, which encapsulates the various events and support centered on the development of academic writing

at the graduate level, particularly regarding thesis and dissertation research. tadMatters™ includes tadWorks (graduate workshops, trainings, seminars, etc. provided from admission to graduation to develop academic writing and research skills), tadDays (a collaboration event with stakeholders and industry to inform Graduate students of available scholarships, internships, and other sources of research funding), tad Boot Camp (an intensive thesis/ dissertation writing event centralizing campus-wide support in one convenient location), and tadTalks™ (an international grad student event showcasing various perspectives

on the graduate research experience).

The primary aim of the tad Boot Camp, with a tagline 'environment matters', is to enable students to make substantial process in thesis/ dissertation writing in a supportive, distraction-free environment and to be part of a community of like-minded graduate students. This year, the tad Boot Camp provided 12 hours of academic writing and research support over a three-day period. Bringing in nearly 250 graduate students from 9 colleges, the boot camp invited teams from Writing Support in the Office of Graduate Studies, QU Library, Statistical

Consulting Unit (SCU), Social and Economic Survey Institute (SESRI) as well as nearly 30 experienced faculty researchers from all disciplines to work with graduate students at different stages of the thesis/dissertation writing process. Professor Mariam Al-Maadeed, the Vice President for Research and Graduate Studies, said of the event, “It is one of our signature events focused on supporting graduate students and their research, and we look forward to growing the event each year based on the feedback from participants and attendees”. The Dean of Graduate Studies, Dr. Ahmed Elzatahry, added that “attendance to this year’s boot camp nearly doubled that of last year, which is a strong indicator that graduate students are inheriting value from the event”. The Assistant Dean for Learning Support in the Office of Graduate Studies, Dr. Mary Newsome, initiated the tad Boot Camp at Qatar University in 2018 out of a growing demand for Graduate students to have a “good start”



Part of the tad Bootcamp activities for graduate students from the Law program

on their written thesis early in the semester. She added, “the boot camp helps graduate students get words on a page, which is often one of the biggest obstacles to transitioning from an approved thesis proposal to a thesis first draft”.

Graduate students who participate in all three days of the boot camp are eligible to apply for the tad Boot Camp Award, which is in recognition of high-caliber graduate research that

demonstrates a strong potential for publication to a high-impact factor journal. Ultimately, the tad Boot Camp Award is a reflection of the quality of research that can be produced when students take full advantage of the resources and services available to support graduate research at Qatar University. The award is presented by the Vice President for Research and Graduate Studies at the Annual Research Forum.



College of Education Masters Students at tad Bootcamp 2020 “How to Find a Thesis Topic”

Center for Advanced Materials Organizes Seminar on New High-Performance Poles for Water Desalination Using Electricity: Emerging Water Treatment Technology

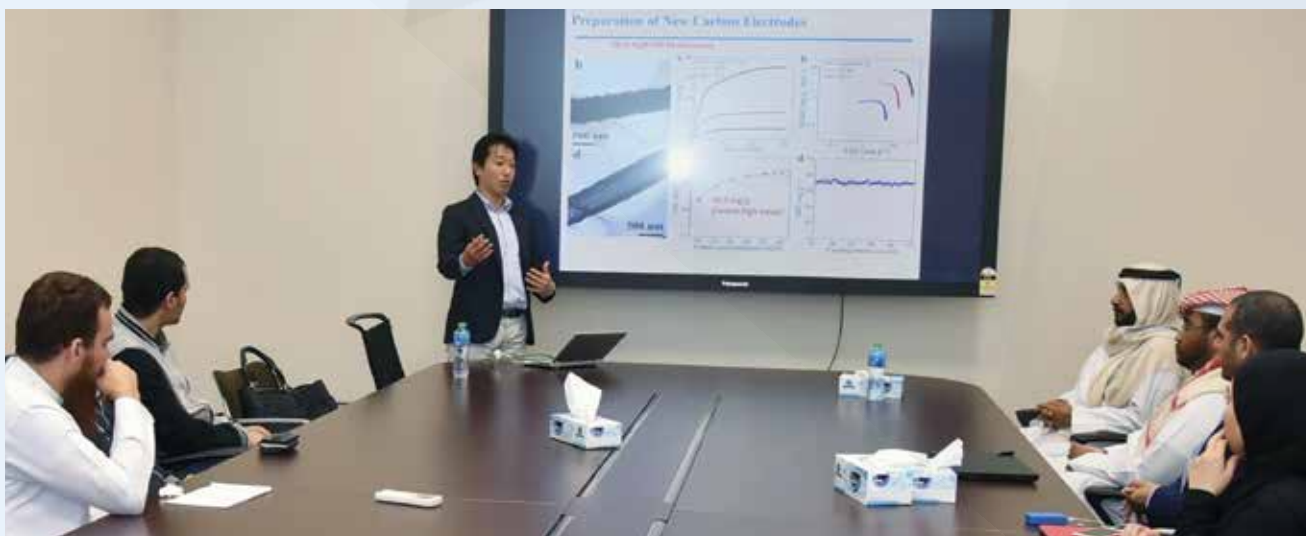

Seminar on emerging water treatment technology at the Advanced Materials Center

Organizer: Center for Advanced Materials

Date: January 19, 2020

Venue: Research Complex-Qatar University

On January 19, 2020, the Center for Advanced Materials held a seminar at the Research Complex titled Engineered Nanoporous Materials for Various Applications and New High-Performance Poles for Water Desalination Using Electricity: Emerging Water Treatment Technology.

The seminar hosted three researchers from University of Queensland, Australia, and the National Institute of Materials Science in Japan. The delegation was led by Professor

Yosuke Yamauchi, a professor at the National Institute of Materials Science in Japan and the Department of Chemical Engineering at the University of Queensland, Australia, who is Thomson Reuters' Highly Cited Researcher in Chemistry and Catalysis for the last three years. He was selected as one of Australia's Top 40 Researchers, in addition to receiving The Young Scientists' Award by the Ministry of Education, Culture, Sports, Science and Technology, Japan, in 2013 and The Chemical Society of Japan Award for Young Chemists in 2014. Professor Yamauchi, 39 years old, has about nine hundred published scientific papers and lectures. His H-index

impact is almost 100, and the i10-index has exceeded 500, which indicates the importance of his researches in the field, as can also be seen from the number of quotations which were reported for his research and which exceeded thirty-seven thousand scientific quotes.

The seminar was held under the patronage of Dr. Nasser Alnuaimi, Director of the Center for Advanced Materials, and in the presence of Professor Yamauchi and his team consisting of Dr. Muhammad Shahriar Al-Hossain, lecturer at the University of Queensland and a member of the University's Student Cooperation Committee, as well as Dr. Xingtao Xu,

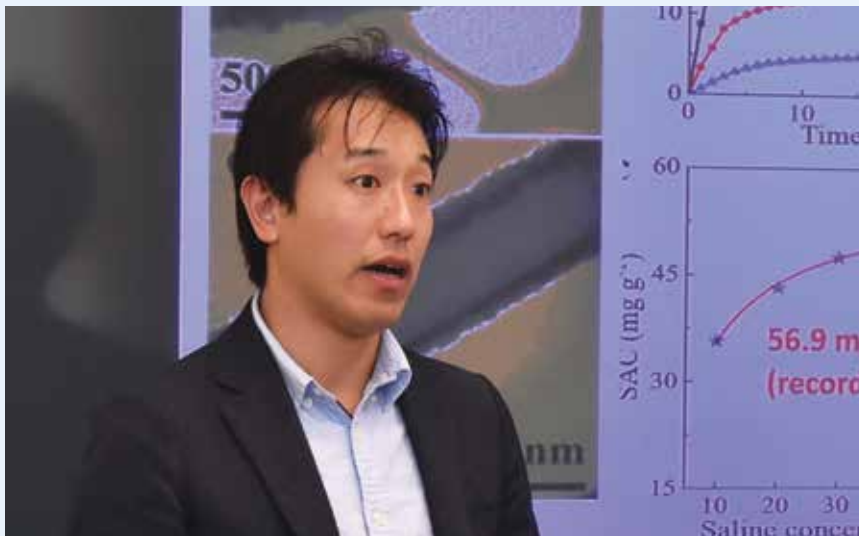

Professor Yosuke Yamauchi, a professor at the National Institute of Materials Science in Japan and the Department of Chemical Engineering at the University of Queensland, Australia



Dr. Nasser Alnuaimi, Director of the Center for Advanced Materials-Qatar University

a specialist in sea water desalination using modified poles with modern nanomaterials with a high surface area and ability to bind to dissolved ions of seawater salts; and many researchers from Qatar University at the Center for Advanced Materials and some specialists in the same industry in the State of Qatar.

Professor Yamauchi gave his presentation, focusing his academic speech on the new nanoporous materials and its applications in energy and environment. After the seminar ended, Professor Yamauchi and Dr. Xu participated in a discussion with researchers at Qatar University and devoted mainly to presenting the latest developments achieved by their research groups in Japan and Australia in Water Desalination, with electrochemical capacitors and addressing the economics of this emerging industry.

Professor Yamauchi expressed his willingness to cooperate with the State of Qatar in providing new materials that he developed, which he described as more effective and efficient in terms of performance and expenditures than water desalination technologies

currently existing in Qatar. His speech included cooperation in anti-corrosion of materials in the oil and gas sector by providing modern types of long-life and anti-corrosion coatings, as well as reducing the proportion of carbon dioxide emitted in Qatar and converting it into useful fuels that can be used as another source of energy, as well as looking for better ways to conserve food using some natural ways to maintain original quality without any artificial agents.

The discussion pointed to the participation in various projects with goals and programs proposed by the QNRF as

well as internal projects at Qatar University that include international cooperation and joint funding.

Prof. Yamauchi also discussed future academic and research cooperation with Dr. Ahmed Elzatahry, Dean for Graduate Studies at Qatar University, as well as with Dr. Nasser Al-Nuaimi and Dr. Shahriar Al Hossain with a view to help students receive training at modern research facilities at the University of Queensland, in addition to obtaining a dual degree from both universities, and spending one year of study in Qatar and one year in the University of Queensland.

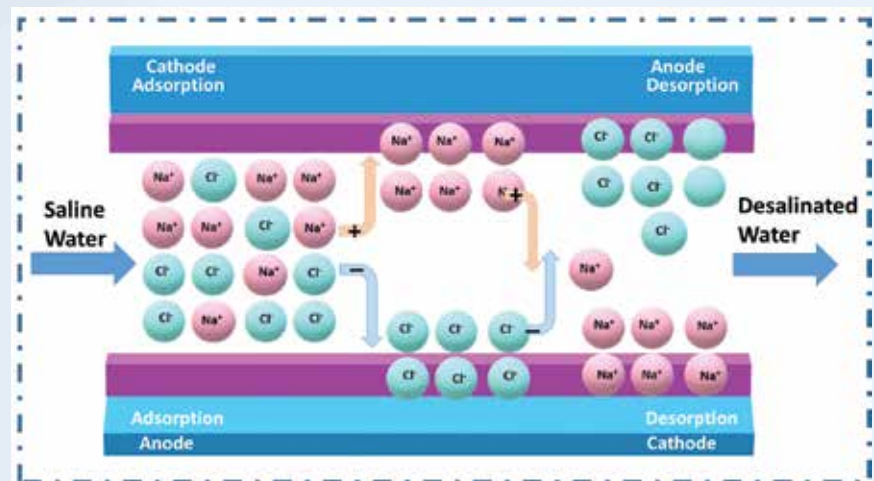

Schematic for water desalination mechanism using the capacitive deionization technique

QU Celebrates International Day for Women and Girls in Science 2020



From right to left: Manal Mansour, PhD student at Qatar University, Dr. Anna Paolini, Director of UNESCO's Doha Office, Dr. Hassan Al-Derham President of Qatar University, HE Dr. Hamda Al-Sulaiti, Secretary-General of the Qatar National Commission for Education, Culture and Science, Prof. Mariam Al-Maadeed, Vice President for Research and Graduate Studies at Qatar University, Dr. Mohammed Alsafran, Director of the Central Labs Unit at Qatar University, Dr. Ibrahim Al-Maslmani, Advisor at Vice President for Research and Graduate Studies Office at Qatar University

Organizer: Qatar University (QU), in cooperation with the UNESCO Office for the Gulf States and Yemen and the Qatar National Commission for Education, Culture and Science

Date: 12 February 2020

Venue: Research Complex - Qatar University

Empowering women and girls to participate in all scientific fields has made them an active element that contributes towards achieving progress in innovation and creativity in both Arab and Western worlds. In this regard, and with a view to encouraging women, the UN General Assembly has adopted a resolution by which it declared 11 February of every year an International Day for

Women and Girls in Science. Qatar University, as a recognized educational edifice, comprises of a unique and distinguished group of women in the field of science and innovation, whether they are students or researchers. Qatari women have accomplished outstanding successes, such as patents and discoveries, honoring the State of Qatar and enhancing the country's image on various international forums.

In advancing the UN sustainable development goals (SDGs) and towards the fulfilment of Qatar National Vision 2030, Qatar University celebrated the International Day for Women and Girls in Science 2020 on Wednesday, 12 February 2020, for the purpose of empowering and motivating current and future

generations of girls to confront and cope with modern scientific challenges. This celebration was organized in collaboration with the UNESCO Office for the Gulf States and Yemen represented by the UNESCO Office in Doha, in addition to the Qatar National Commission for Education, Culture and Science. The event witnessed the presence of HE Dr. Hassan Al-Derham, Qatar University President, HE Dr. Hamda Al-Sulaiti, Secretary-General of the Qatar National Commission for Education, Culture and Science, and Prof. Dr. Mariam Al-Maadeed, VP for Research and Graduate Studies, besides a group of male and female researchers interested in the field of science, and a number of students of Rawda Bint Jassim Independent Secondary



Honoring Dr. Anna Paolini, Director of UNESCO's Doha Office

School for Girls, Rawdat Rashed Independent Primary-Preparatory-Secondary School for Girls and Zubaida Independent Secondary School for Girls.

The celebration saw encouraging words from many key speakers. Dr. Anna Paolini, Director of UNESCO's Doha Office, gave a speech in which she said that the percentage of female researchers in STEM areas is constantly increasing. She emphasized the importance in holding such annual events in cooperation with Qatar University in order to share female researchers' experiences, exchange expertise on research experiments, identify challenges and the ways to solve them and attract more researchers interested in science.

HE Dr. Hamda Al-Sulaiti, Secretary-General of the Qatar National Commission for Education, Culture and Science, spoke about the State of Qatar's role in supporting women and girls in the fields of science. She said, "the State of Qatar attaches significant attention and gives great support to improve the position of Qatari women in the field of science and scientific research, consolidate the bases of constructive scientific thinking. That is by providing a variety of

specialized programmes and scholarships for studying the most recent technological advances, being familiar with the best emerging scientific developments, along with allocating scientific awards to the most salient research projects for female students. That is besides the organizing and hosting of various major international conferences and initiatives to spread scientific culture among girls."

Prof. Mariam Al-Ali Al-Maadeed, Vice President of Qatar University for Research and Graduate Studies, stressed in her speech on the fact that the State of Qatar

supports Qatari women which is reflected in their equal stature with men according to numerous laws, legislations, plans and strategies in the country. It also provides them with work opportunities and leadership positions allowing them to play an outstanding role in achieving Qatar's National Vision 2030. Furthermore, Qatar pays particular and extensive attention to women and girls based on QU's experience where female students stand for 76% of the total student count. Moreover, the percentage of participation of girls and female staff members in scientific research and undergraduate and postgraduate studies is continuously increasing each year. Dr. Mariam said, "in addition, QU activities reach out to include schools through various programs, such as Al-Bairaq and Tamkeen. These prominent and purposeful programmes aim at qualifying and developing national skills and encouraging students to pursue their careers in scientific specializations and participate in research and innovation".

Agenda of the ceremony included an invitation extended to a distinguished Qatari woman in the field of science. Dr. Bothina Al-Mulla, a gynecologist and obstetrician at Sidra Medical and Research Center and Hamad



Honoring HE Dr. Hamda Al-Sulaiti, Secretary-General of the Qatar National Commission for Education, Culture and Science

Medical Corporation, was invited to participate in the ceremony. Dr. Buthaina Al-Mulla delivered a speech titled “Al Dana”, where she emphasized the role that Qatari women play in the society in general, and in the field of science in particular, pointing out that women have become an example to be followed in the field of medicine. They work hard and persistently to overcome difficulties and challenges encountered by them in general, demonstrating that ambition and knowledge are measureless, and dreams have turned into reality through perseverance, diligence, and taking hold of opportunities. It is worth mentioning that Dr. Buthaina received distinct awards, including the Scientific Excellence Award in 2012 under the patronage of the HE Sheikh Tamim bin Hamad Al-Thani, and the title of Ideal Personality for the year 2012 from Weill Cornell Medical College, not to mention Excellence in Community Service Award in 2011.

A presentation on Al-Bairaq Program was also given and was presented by the Center for Advanced Materials, Qatar University. Al-Bairaq program is a unique education project. This program allows Qatari high school students to work in teams

with prominent scientists on scientific topics at the level of Qatar University. Its importance lies in building human capabilities and a knowledge-based society. Two students, Amna Al-Jumaili from Qatar University and Munira Al-Shahwani from Al-Khor School also gave a presentation about their participation in this program and its significance in developing students’ research skills and improving and increasing theoretical knowledge with practical experience in various laboratories by using different techniques.

Another Presentation on the Empower Generations Consortium Project of the College of Health Sciences and Biomedical Research Center at Qatar University was given. The Empower Generations Consortium project, which was approved by the Ministry of Education and Higher Education in the State of Qatar as a key initiative for building national capacities in the field of life sciences and health sciences, aims at reaching an accurate understanding of sciences and how they are used to serve people, particularly in the health sector. The project also introduced a research presentation titled, “The Effect of Ginger and Turmeric Roots on Breast and

Lung Carcinoma Cells”.

Finally a Panel discussion of female students from Qatar University titled “Empowering Future Generations of Girls in the Field of Science” was held which concluded Qatar University’s celebration of International Day for Women and Girls in Science 2020. Where the panel discussion was moderated by Fatma Al-Maadeed who is a Master’s student majoring in Materials Science and Technology at the College of Arts and Sciences. The panel comprised of the following students: Manal Mansour-a PhD student at the College of Engineering majoring in Engineering Management; and Balsam Rizeq-a PhD student at the College of Arts and Sciences majoring in Cellular and Molecular Biology/ Cancer Research; Mina Shokrallah- a Master’s student at the College of Engineering majoring in Engineering Management; Hanan Al-Keldi-an undergraduate student from the College of Health Sciences majoring in Nutrition; and Sara Thiab an undergraduate student from College of Pharmacy.

The students panel discussion started with a short account about the academic and professional life of the participants and their aspirations in the fields of Science, Technology, Engineering and Mathematics (STEM). Sharing opinions on the current challenges women and girls face in the community, and the best ways of encountering them. Personal and international achievements made by a group of creative women in the field of science in various areas and at different levels. Motivating female students, in particular high school students to be familiar with the available fields of study, and how to choose an academic specialization, set goals and priorities, manage time and achieve a balance between work, knowledge and family.



A panel discussion of female students from Qatar University titled “Empowering Future Generations of Girls in the Field of Science”

“Towards a New Gulf Security System: Abandoning the Zero-Sum Approaches” Conference at Qatar University

Organizer: The Gulf Studies Center at Qatar University, in cooperation with Al-Jazeera Center for Studies

Date: 19-20 January 2020

Venue: Ibn Khaldoun Hall - Qatar University

Recently, interest in the Gulf security, its location and role in the international and global system has started to become clear and prominent, in addition to the increasing studies and research touching on the security of the Arab Gulf Region. However, the most interesting thing about these studies is that they are coming from outside the region and mainly reflect the perception and understanding of people from outside about the region and its security system. In other words, what is written about the Gulf’s security system is done based on the perceptions of these external actors in relation to the region’s affairs and security. Therefore, on 19-20 January 2020, and in cooperation with Al-Jazeera Center for Studies, QU’s Gulf Studies Center co-organized a conference entitled: “Towards a New Gulf Security System: Abandoning the Zero-Sum Approaches”, with the participation of about 25 analysts, researchers, academics and others in political sectors around the Gulf region and the Arab world; in addition to participants from Iran, Turkey, the United



Dr. Hassan Al-Derham, President of Qatar University, during the opening session of the Conference

States, and Europe.

In his opening remarks, the President of Qatar University Dr. Hassan Al-Derham, welcomed researchers and politicians from Qatar and beyond, stressed the importance of in-depth discussions on issues that contribute to increasing knowledge as well as studying and analyzing regional and international developments. Dr. Mukhtar Al-Mukhtar Khalil, Director of Al-Jazeera Center for Studies, stated that the conference aims to analyze the problem of Gulf security, explore new approaches that take into account the interests of relevant parties and provide practical solutions to the issues of this region. Director of the GSC Dr. Mahjoob Al-Zwairi, explained that

the reason that drives the majority of studies to investigate the role of these external perceptions about the region’s security system emanates from the vital role the region plays as well as its significance as a source of oil and gas energy. This, in addition to the great potential the region has, most prominently, controlling the Strait of Hormuz, which is one of the most important oil and gas portals for the world; and it is here, that the political importance of the region for world powers arises.

The conference discussed the security issue in the Gulf region, defining its contexts, current threats and exploring new security approaches to address those threats. It also discussed economic security, supply lines,



A group photo of researchers in one of the Conference sessions

and other respective issues. The conference hosted seven research sessions over two days, in which a number of major issues were discussed, which are as follows:

The Gulf system and its position in the international and global economic system.

Conventional and non-conventional security threats in the Gulf.

Economic safety and supply lines.

Security arrangements in the Gulf region: history and patterns.

The Gulf and the Iranian-American conflict.

Turkey and the Gulf Security: Perceptions and Policies.

Towards a new Gulf security system.

Economic and political significance of the Arabian Gulf region has made it the focus of attention, interest and ambitions of the world's leading countries over the past decades. Such interest has worked to merge local affairs of the region with the global ones, which has contributed to creating the state of tension and insecurity as a dominating force for decades. It is the same reason the region's economic, political and social capabilities and resources have been generally depleting. It should be mentioned that when talking about the Gulf security system, which falls under the

umbrella of the GCC States, the surrounding geopolitics, mainly including that of Iraq, Yemen and Iran, would be the main target. Events happening with in countries surrounding the region as well as their security cannot be ignored, mainly due to the proximity and closeness of these countries to each other, making it easier for any political tension to be reflected on neighboring countries.

The Most Prominent Challenges for Gulf Security System can be summed up as follows:

During the past three decades, the Arabian Gulf region witnessed many threats and challenges that still exist and are developing and expanding. They played an important role in the region's state of political instability throughout this period. Perhaps one of the most important of these challenges relates to the inability to identify the source of threat or to distinguish enemies from allies. In other words the inability to determine whether the source of threat is external or from regional or non-regional countries.

The second challenge facing the Arabian Gulf region lies in the political stability of the region and the surrounding area, which can be clarified by looking at the political events and successive occurrences happening in the region. At the beginning, Arab

nationalist ideas posed a threat to the security of region's countries, and then came the Islamic Revolution in Iran, which posed a threat that is directly related to the internal political landscape of the Gulf region.

Emergence of non-governmental or non-international actors in the region as new players, such as the armed militias has become an important factor in affecting stability of the region's security. These groups usually represent the extended arms of specific countries and they would be used to achieve certain goals. The Popular Congregation Forces in Iraq and Hezbollah in Lebanon, among others, are examples of such groups. However, these groups at times have posed a security threat to their own countries and to countries of the region in general.

The fourth challenge is related to the ability to achieve and maintain internal harmony in light of rapid political, economic and social changes taking place in the world. For example, preserving national identity is challenging in light of openness to the world as well as technological openness. Development of knowledge and easier access to information are other examples of this type of challenge.

Lastly, this research conference is a significant contribution from Qatar University with regards to clarifying the status of the Gulf security situation during one of the most difficult periods of geopolitical conflict in the Gulf region. The academics, experts, and politicians who participated in the conference presented a vision for the future of the region, as well as solutions that help decision makers when designing policies that define the future, including the following:

Stressing that Gulf security is a concept produced from the

outside and not from the inside, through Western political and media circles and is related to the other's vision of the region's stability. This concept really needs an internal review that relates to how the region perceives its security and stability, i.e. how security and stability issues are being regarded in the Gulf region.

Economic stability is related to many issues such as oil and gas sales, food security, and cyber security, as well as the network of international relations and alliances that includes important players other than Western countries who have major roles in the region, like Iran and Turkey, when it comes to the Gulf's security.

Focusing on the changes taking place in the world, the change in the balance of power, the decline of the American role in the region and in other places around the world, as well as the decline in what the United States is doing in terms of its unwillingness to lead the scene in many issues, and allowing other players to play this role instead; their impact on the security and stability of the Gulf region and would such actions prompt the emergence of other



Dr. Shafiq Al-Ghabra, Professor of Political Science, Kuwait University

players who might be interested in the Gulf? Such as China and Russia.

The Gulf security issue still needs to be understood, given variables such as: population, economic and technological changes, as well as information flow, knowledge openness, changing concepts of security and stability. Here we talk about changing science and theories, a change in the roles of international players and so on, leading to the necessity of continuous review and the need for a different awareness to deal with security

challenges.

The conference made it clear that security is achieved only through collective security. Should the regions around the Gulf be unstable, this would be reflected on the Gulf States. Therefore, as stability is a requirement for all, so must be the cooperation for security.

Conclusion:

To conclude, it is worth noting that the internal security of the Gulf States is worth being concerned about. It is important for the State to maintain security from within, in order to proceed with achieving regional security. It should also be noted that the State, while playing its role in providing security from within, might establish alliances from abroad as security umbrellas that help it in carrying out such a role. In addition, the idea of State stability is a prerequisite when talking about providing a Gulf security system, as this security system cannot be provided without countries enjoying a state of stability. Moreover, there is an urgent need to maintain a collective Gulf security system that provides at least a minimum level of security for all, which may mitigate security and political tension in the region.



Dr. Muhammad Al-Musfir, Professor of International Affairs, College of Arts and Sciences Qatar University

International Conference: Islamic Economics and the Question of Development: Critical and Innovative Analyses

Organizer : Ibn Khaldoun Center for Humanities & Social Sciences and College of Business and Economics at QU, in cooperation with University of Oxford

Date: 8-9 February 2020

Venue: Research Complex – Qatar University

In cooperation with the University of Oxford and College of Business and Economics at Qatar University (QU), Ibn Khaldoun Center for Humanities and Social Sciences organized an international conference on the 8th and 9th of February 2020, entitled “Islamic Economics and the Question of Development: Critical and Innovative Analyses”, at the Research Complex Building (H10) at QU. Seventeen researchers participated in the conference, where they presented their scientific research through which they discussed the three themes of the conference, namely: Contemporary Islamic Financial Markets.

Contemporary applications of Waqf (endowment) and Zakat (alms).

Islamic Banking and Insurance.

This conference was held within Ibn Khaldoun Center’s strategic domains of “renewal and bridging”. It also highlighted the criticism and innovation aspects of Islamic economy in its various branches. The conference was opened with a speech from Professor Mariam Al-Ali Al-Maadeed, Vice President for Research and Graduate Studies, in which she said: “Emerging realities have created new duties which put Islamic economy in the face of many challenges, including politics, governance, production, consumption and others. Hence,



Opening session of the International Conference ‘Islamic Economics and the Question of Development’

the issue of innovation in Islamic economy becomes an urgent matter that assigns researchers and legislators the task of creating a modern system which understands the present reality and anticipates the future in a manner where economic and intellectual aspects are integrated while religious and ethical values are preserved for all people.” Dr. Al-Maadeed also noted that QU places scientific research at the top of its priorities and that this conference is a quantitative step to achieve visions and research that respond to emerging requirements and support the role of Islamic economics in the process of development and transition towards knowledge economy, justice and prosperity.

Dr. Al-Maadeed concluded by thanking both the participants and attendees, wishing the conference with overall success.

Then, it was time for the opening session, which was a scientific debate entitled: “Islamic banks: are they applying or circumventing Islam?” The session was chaired by Dr. Nayef bin Nahar, Director of Ibn Khaldoun Center for Humanities and Social Sciences at QU. Prof. Dr. Ali Mohiuddin Al Qaradaghi, Prof. Dr. Ayman

Ali Saleh, Dr. Sultan Ibrahim Al-Hashimi and Dr. Hamid Al-Hamoud Al-Ajlan all participated in the session, where each spoke his mind about the issue of Islamic banking. Questions were posed, such as: Is there such a thing as an Islamic Economy? Assuming its presence, does it serve society and the State or not? What are the problems of Islamic banking, whether at the level of theory or application? Is all the talk about Islamic banks in terms of development and economic prosperity true or not?

After that the conference sessions began. The first session was on critical and innovative studies in financial markets, while the second session was an interactive session on Quranic basis for Islamic economics. The third session was on critical and innovative studies in Zakat and Waqf. The fourth session was on innovation in Islamic banking and insurance, and the fifth session on critical studies in Islamic banking. The final session was an open discussion on ways to develop Islamic economics. It was chaired by Dr. Nayef bin Nahar, and a large number of professors and doctors, interested in Islamic economics participated therein.

They discussed many problems that Islamic economy suffers from, including: conversion of variables to constants by some researchers; absence of clear criteria in many services, tools and transactions; the problem of stereotyping, i.e. a researcher is not able to deviate from the pattern existing in the scientific research field; the attempt to combine contradictions, that is to say, to start from Western intellect, then drag Islam to cope with it; exaggerated simulation of western products; not turning scientific proposals into applicable laws and regulations that would be binding to concerned authorities... etc. The participants also offered solutions for such problems from their own perspectives. The issues raised by the participants were well received by the attendees during the sessions and they asked many questions about them. At the end of the conference, researchers arrived at a group of conclusions and recommendations, most notably: Raise community awareness on the importance and role of science Waqf in disseminating and developing science through introducing community to leading international experiences in scientific fields and through informing people that science Waqf is one of the most important ways to ensure and maintain the educational process, especially with the decline in financial resources during times of crises and economic turmoil. Establishment of specialized institutions to invest Waqf funds for the purpose of ensuring capital preservation and appropriate financial returns. Such utilization of Waqf funds, allowed some universities, such as Harvard University and others, to achieve first grades in global rankings because of the quality of their educational outcomes. Directing Waqf conferences and research to new research areas, such as the Waqf's relationship with the economy, urbanization, politics and other sciences and areas that open new horizons for Waqf.

Zakat has a great ability to

influence economic activities, i.e. the real Gross Domestic Product, which means that Zakat can be used as a significant tool to stimulate economic growth and reduce inequality in the distribution of income and wealth, as well as the gap between the rich and poor. Sukuk holders' current beneficial ownership of assets is not compatible with ownership in accordance with the principles of Islamic Sharia, as it limits Sukuk holders' right to asset disposal. Green Sukuk is a great area of investment and can contribute to financing sustainable projects on a large scale. It forms a link between two geographically distinct markets: Muslim investors market and conventional investors market. While such green Sukuk are important, they lack Islamic Jurisprudence foundation and the credibility of their recent editions is marred, which prevents Green Sukuk from developing in desired manner and speed.

Rules related to gold and silver must be renewed in our modern times, as people have stopped dealing in them, especially as they are marred with usury, "Riba", however, their value is a matter of custom, and custom changes with times and places.

Incorporation of smart contracts into the platform of Islamic financial market enhances the use of financial technology and facilitates spreading Islamic finance in the world. Therefore, the process of creating a smart Islamic financial market has become an urgent necessity for the Islamic world because it ensures access of the largest number of subscribers to formal financial products in an easy manner and at a lower cost. Hence, monetary and financial policies must be developed to be more open to technology and Islamic regional cooperation must be supported to facilitate the movement of funds and investments, especially in financial markets.

Proposals to develop Islamic banks must be on two parallel tracks; the first is a short and medium-term track, while the

second is a long-term and strategic one.

Upon studying the failure factors of their counterparts in conventional banks, evaluating the investment companies of some Islamic banks with financial investments and correcting their deviation, it is required to establish Islamic banks specialized in real and direct investment, such as agricultural, real estate and industrial banks, which are based on direct financing or partnership with others.

Governance must be applied in Islamic banks in accordance with an Islamic approach, so that accurate reports can be prepared on the banks' activities and Islamic nature and so that Islamic banks' risk can be dealt with. Additionally, the role of Central Bank must be activated in order to increase awareness of banks and financial reports users in respect to the significance of disclosing risks and its role in reducing information asymmetry, as well as in relation to preparation of a separate report on these risks to be as a complement to financial reports. Blockchain is a revolutionary technology in a world of value exchanging. It is characterized by placing trust and authority in a decentralized network instead of central networks and agencies, which is an opportunity for the sector of Islamic finance and banking to redraw and reshape its position in global financial system. Smart contracts allow risk reduction and ensure a comprehensive and transparent decentralized financial system, which enhances the establishment of the Islamic values of fairness and transparency and solves the problem of transactions risk. Areas of blockchain technology application expand to include almost all the services provided by Islamic banks, therefore it is necessary to work hard, in cooperation with establishments and institutes specialized in financial technology, to develop Islamic financial products based on this technology and to improve legislative infrastructure and regulation.

“Philosophy, as a Bridge Among Cultures” The Second International Symposium of the Philosophy Program, Department of Humanities, College of Arts and Sciences

Organizer: Department of Humanities, Philosophy Program-College of Arts and Sciences - QU

Date: 13 November 2019

Venue: Library Building - Qatar University

On the World Philosophy Day, and in participation with the United Nations Educational, Scientific and Cultural Organization - UNESCO, the Department of Humanities (Philosophy Program) at the College of Arts and Sciences at Qatar University, in its annual celebration of the World Philosophy Day, held the second international symposium entitled, “Philosophy as a Bridge Among Cultures.”. Every culture, as a way of life, needs philosophy. We contribute to every culture with ideas, beliefs, attitudes, expectations, and practices that help us find the best way to live, that is, to live according to culture in its true sense. Since philosophy offers different and multiple perspectives that philosophers have presented, both ancient and modern, that help us understand the world together, philosophy is the bridge through which different and multiple cultures communicate.

The International Symposium was held on 13 November 2019, in the Library Building, Hall 117,



Participants in the Second International Symposium of the Philosophy Program, Department of Humanities, College of Arts and Sciences

at Qatar University. Some of the philosophers were invited to talk about the role of philosophy in dissolving differences and disputes cultures and calling for acceptance of cultural pluralism. The philosophers who attended were: the Tunisian philosopher Prof. Dr. Mohamed Mahjoub, a distinguished Professor of Higher Education, professor of philosophy at the University of Tunis Al-Manar, and the founder of the Tunisian School of Phenomenology and Hermeneutics, Prof. Khanjar Hamyeh, a full-time professor of modern and contemporary philosophy at the Lebanese University, and Prof. Dr. Mohamed Abattouy, Professor of history and philosophy of science at the University of Mohammed V in Rabat, who is currently a

researcher at the Doha based Arab Centre for Research and Policy Studies, and member of the academic team compiling the Doha Historical Dictionary of Arabic Language lead by the Arab Research Centre.

Philosophy was and is still the crown that a person puts on his/her head to become worthy of his/her humanity. Since philosophy is the mother of arts and sciences, the Dean of the College of Arts and Sciences, Professor Dr. Ibrahim Al-Kaabi inaugurated the symposium. In his opening remarks, he stressed the need for a knowledge-based society. This has become an urgent need in our time, especially after the changes and transformations that happen every day in the world around us. Perhaps the most important and most prominent of these

changes and transformations is the transcendence of the knowledge society beyond narrow and closed specializations, and the call for a transdisciplinary knowledge or interdisciplinary-knowledge, that is based on pluralism, diversity and renewed dialogue between knowledge and cultures. The Head of the Humanities Department, Dr. Maryam Al Hammadi, also delivered a speech welcoming the guests of the Second International Symposium of the Philosophy Program. She focused on the importance of philosophy and its ability to transcend the different boundaries of knowledge, and to organize open and pluralistic dialogues in the relationship between society and knowledge. She added that the importance of this symposium lies in stimulating ideas and upholding the question and critical function that philosophy performs alongside other humanities and social sciences. As UNESCO attaches great importance to philosophy, because its comprehensive mission is consistent with the mission of philosophy, which always aspires towards a holistic view, Dr. Anna Polini, Director of the UNESCO Regional Office for the Arab Gulf States and Yemen in Doha, shared a speech delivered on her behalf by Miss Donia Abdel-Wahid, Head of the Natural Sciences Sector and supervisor of the UNESCO Social Sciences and Humanities Program. Furthermore, in the confirmation of the cultural role of Qatar, which emphasizes communication peoples and cultures, Miss Kulthom Abdul Rahman, representative of Qatar's Ministry of Culture and Sports, cultural affairs specialist and cultural researcher, gave a speech on: "Qatar and Intercultural communication." She pointed to the role played by the State of Qatar represented by the Ministry of Culture in building bridges among peoples and different cultures.



Dr. Khaled Qutb, Professor of Modern Philosophy, College of Arts and Sciences at Qatar University

The symposium was moderated by Prof. Dr Khaled Qutb, Professor of Philosophy, Department of Humanities, Curator and Executive Director of the symposium. He emphasized that the goal of celebrating World Philosophy Day is:

- Holding meetings philosophers in various countries to allow communication and the dissemination and exchange of ideas among them.
- Highlighting the value of philosophy and the need to advance its teaching so that a critical, contemplative, questioning and independent philosophical mind is always present in our lives.
- Understanding the world and promoting the values of tolerance and peace. If wars are first born in the people's minds, we must first build the strongholds of peace in these minds. This can only be done in the presence of philosophy as a systematic, and rational way of thinking.

Prof. Dr. Muhammad Mahjoub presented a paper titled, "Is Philosophy a Bridge for Cultures?" citing a brief definition of culture based on the logic of privacy. Then it moves to inquire through specific examples about the extent to which philosophy can be a possibility for dialogue in this context: What is important in this question is, of course, the determination of the perspective

with which philosophy can be a bridge for dialogue among civilizations.

In his paper titled, "Philosophy as a Bridge between Cultures" Prof. Dr. Khanjar Hameya focused on the need for a pattern of contemplation in the world. This pattern must be built and evaluated upon a firm confirmation of the urgent need for dialogue, at the peak of a liberal emission of privacies, and in light of diversity based on multiple sources and origins.

Prof. Dr. Mohamed Abattouy in his paper titled, "Acculturation in Islamic civilization as a lever for tolerance in the classical phase", focused on the role played by Arab sciences in spreading a culture of tolerance between science and cultures through translations and localization of foreign sciences within the Islamic environment.

The symposium passed a set of recommendations, including:

- Encouraging inter-research, studies that address contemporary intellectual and cultural issues at the regional and international levels, so that the role of philosophy becomes central to these research and studies.
- Encouraging female students whose minor at Qatar University in Philosophy, to pursue their graduate studies and overcome the difficulties that prevent this from being achieved.
- Raising the awareness of the Gulf public opinion about the importance of philosophy in developing rational, critical and creative thinking.
- Encouraging the Ministry of Education and Higher Education and research centers in the State of Qatar to include Philosophy in their curricula and conduct educational workshops for educators on the importance of philosophy in building mental capabilities and developing critical thinking among students.

Ninth Awareness Workshop for Undergraduate Students on Agreements on Weapons of Mass Destruction



Dr. Hassan Al-Derham, President of Qatar University, Brig. Gen. (Air) Hassan Saleh Al-Nesf, NCPW Chairman, Prof. Mariam Al-Maadeed, Vice President for Research and Graduate Studies, and a number of dignitaries, researchers and students during the Workshop

Organizer:
The National Committee for the Prohibition of Weapons (NCPW) - Ministry of Defense

Date: 27 January 2020

Venue: Higher Administration Building, Qatar University

Qatar University pays great attention to its students, promotes positive social participation, and helps organize workshops needed by University students and community. To that end, and under the patronage of His Excellency Dr. Khalid bin Mohamed Al-Attiyah, Deputy Prime Minister and Minister of State for Defense Affairs and Qatar University hosted on Monday 27 January 2020, the 9th Awareness Workshop for Undergraduate Students on “Agreements on Weapons of Mass Destruction,” in cooperation with the National Committee for the Prohibition of Weapons (NCPW). The workshop was held in the Conference Hall at the Admin Building in the presence of Dr.

Hassan bin Rashid Al-Derham, President of Qatar University, Brig. Gen. (Air) Hassan Saleh Al-Nesf, NCPW Chairman, Professor Mariam Al-Maadeed, Vice President for Research and Graduate Studies, and a number of dignitaries, researchers and students.

The 9th workshop comes within the framework of the NCPW’s continuation of its program for university students to promote community awareness of international agreements on WMD as one of the tasks entrusted to the Committee pursuant to the seventh paragraph of Article IV of the Council of Ministers Resolution No. (26) of the year 2004, amended by Resolution No. (45) of the year 2007.

It is noteworthy that the Committee had held the second, third, fifth and seventh workshops at Qatar University as well.

The Workshop was opened with a speech by the NCPW

Chairman, Brig. Gen. (Air) Hassan Saleh Al-Nesf. In his speech, he stressed on the necessity of such workshops to enhance integration and interaction with specialized institutions to communicate messages to society, through increasing horizons of communication with university and high school students, and directing them towards areas of disarmament of WMD and internationally prohibited weapons. “We work with Qatar University to expand and develop horizons of joint cooperation to serve the country, contribute to the implementation of the Qatar National Vision 2030, and to highlight the role of the State of Qatar in promoting international peace and security,” Brig. Hassan said.

Dr. Hassan bin Rashid Al-Derham, President of Qatar University, stressed on the importance of cooperation and complementarity between the university and the

NCPW to educate the community on the major dangers of nuclear, chemical and biological weapons of mass destruction. He also emphasized the role of Qatar University in educating students about peace and security programs in various educational and research track courses. His Excellency stressed on the importance of this workshop as a valuable opportunity in which specialists and students from various institutions and universities engage in discussions and constructive dialogue sessions that enhance mutual cooperation.

Attendees were diverse and exceeded 100 comprising students from several universities such as Qatar University, Weill Cornell University, North Atlantic College, Community College and Ras Laffan Emergency College, in addition to professionals from various State institutions.

The workshop agenda included several lectures on the WMD agreements including a lecture entitled “The NCPW Goals and Achievements”, delivered by Cpt. Abdulaziz Hamdan Al-Ahmad – NCPW Secretary, based on the Committee’s vision in affirming and the role of the State of Qatar in maintaining international peace and security, and the societal and institutional preparedness for this. He further touched on the importance of awareness-raising programs in the community development and the student sector. Furthermore, Dr. Jamila Al-Ajmi - from Hamad Medical Corporation delivered a lecture entitled “**Biological Weapons Convention**”. She stated that this agreement relates to the prohibition on the development, production and stockpiling of bacteriological (biological) and toxin weapons and the destruction of these weapons. The agreement focuses on three main pillars: biological disarmament, and offering aid when a state party is at risk, and encouraging international cooperation for the peaceful use of bacteriological agents.



The NCPW Chairman, Brig. Gen. (Air) Hassan Saleh Al-Nesf.

The awareness workshop agenda also included a lecture titled “**Chemical Weapons Convention**” delivered by Professor Silwan Kamal – a Radiation Expert at the NCPW. This is a multilateral agreement that prohibits chemical weapons and requires their destruction during a specific time frame, and focuses on non-proliferation, that is, the use of chemicals in activities other than those prohibited, complete disarmament of chemical weapons, offering assistance and protection, and finally international cooperation. Mr. Wael Al-Assad – NCPW Adviser also gave a lecture entitled “**Nuclear Weapons Treaties**”, during which he made it clear that the Nuclear Non-Proliferation Treaty is based on preventing the spread of nuclear weapons, denuclearizing, and encouraging peaceful uses of nuclear energy. Moreover, Mr. Wael touched on nuclear arms-related agreements including: Nuclear Non-Proliferation Treaty, to which Qatar acceded in 1989. Qatar also signed the Safeguards Agreement and the Small Quantities Protocol in January 2009.

Comprehensive Nuclear Test Ban Treaty, which prohibits all kinds of nuclear tests and explosions anywhere in the world, has established an international monitoring system that allows on-

site inspections of questionable events.

Towards the end, an open discussion began between students, members and experts of the NCPW about the efforts and achievements of the State of Qatar in the field of WMD agreements, as the state established the Doha Regional Center for training on agreements related to WMD, which is the first of its kind. The Center’s goals are focused on providing capacity-building and institutional strengthening programs to implement international obligations in the areas of security and non-proliferation. Issues related to the agreements mentioned in the workshop were also discussed.

At the end of the workshop, Brig. Gen. (Air) Hassan Saleh Al-Nesf and Professor Mariam Al-Maadeed honored a group of Qatar University students who participated in an advanced training workshop on chemical analysis in the laboratories of the Organization for the Prohibition of Chemical Weapons in the Netherlands. Students were trained on how to deal with special chemical samples according to international standards set by the organization. Those students are: Noor Zaidan and Munira Al-Qahtani from the Central Laboratory Unit, Thoraya Al-Yafei and Munira Al-Mansoori from the Environmental Sciences Center.



Dr. Hassan bin Rashid Al-Derham, President of Qatar University

Qatar University Press Participation in the 30th Doha International Book Fair and the 5th Istanbul Fellowship Program

Doha International Book Fair

Date: 9-18 January 2020

The Doha International Book Fair is one of the oldest and largest international book fairs held in the region. It is considerably popular worldwide due to high demand from the Arab, Gulf and foreign countries.

The first Doha International Book Fair exhibition was held in 1972 under the supervision of Dar Al-Kutub Al-Qatariya (Old National Library). After its launch, the event has been held every two years. It became an annual event since 2002. The Fair has gained an international reputation after attracting a number of the largest and prestigious publishing houses in the world. In the first edition, the number of the participating publishing houses was 20. It increased to 335 publishers, representing 31 countries, coming altogether on an area of 29,000 square meters.



Visit of Qatar University President Dr. Hassan Al-Derham to Qatar University Press at the University booth at the exhibition

Since 2010, the Doha International Book Fair selected various countries as its “Guests of Honor”, starting from the United States to Russia, Turkey, Iran, Japan, Brazil and Germany. France was the Guest of Honor of the 30th edition of the Doha International Book Fair.

Many cultural events are also held on the sidelines of the Fair. They include seminars, lectures, workshops, etc. The Fair was

held at the Doha Exhibition and Convention Center.

The Role of QU Press

This year, QU Press participated for the first time in the Doha International Book Fair launching its first batch of publications. The Press’s participation came within the QU booth. The latter included a corner for displaying, marketing, and selling QU Press’s publications. The participation was successful in terms of marketing and sales.

Events and Activities

Two discussion sessions were held in the cultural salon of the Fair with the authors of the books of “Assemblies of light in pondering the Holy Qur’an and its interpretation through a new scientific educational method” and the “Non-verbal communication in the Qatari culture”. Signing ceremonies of QU Press books were also organized within the QU booth.



Prof. Mariam Al-Maadeed attending a discussion session on the “Gesture and Reference” book published by Qatar University Press

Doha Fellowship Program for Publishers

This year, QU Press became a member in the Publishers Association, which is affiliated with the Ministry of Culture and Sports. The Press also joined the Doha Fellowship Program for Publishers, which is the first of its kind in the region to sell and buy copyrights and translations. The Program also includes meetings and exchange opportunities between several local and international publishing houses.

About Istanbul Fellowship Program

The Istanbul Fellowship Program was launched in 2016 by the Turkish Press and Publishers Copyright & Licensing Society (TBYM), which is the largest professional organization of publishers in Turkey. This program aims to ease the bilateral cooperation between Turkish and foreign publishers, and make Istanbul an exchange market for copyright, publishing and translation.

Then, the second and third editions of the Istanbul Fellowship Program were held. Both editions were successful at the local and international levels. They attracted public and international academic presses. Both editions were co-organized by the Turkish Ministry of Culture and Tourism, Istanbul Metropolitan Municipality (IMM), and TBYM.

The 5th Istanbul Fellowship Program

Date: March 3-5, 2020

The 5th edition featured the bronze membership of Qatar University Press (QU Press). The program also featured the gathering of more than 10 academic presses and Qatar presses.

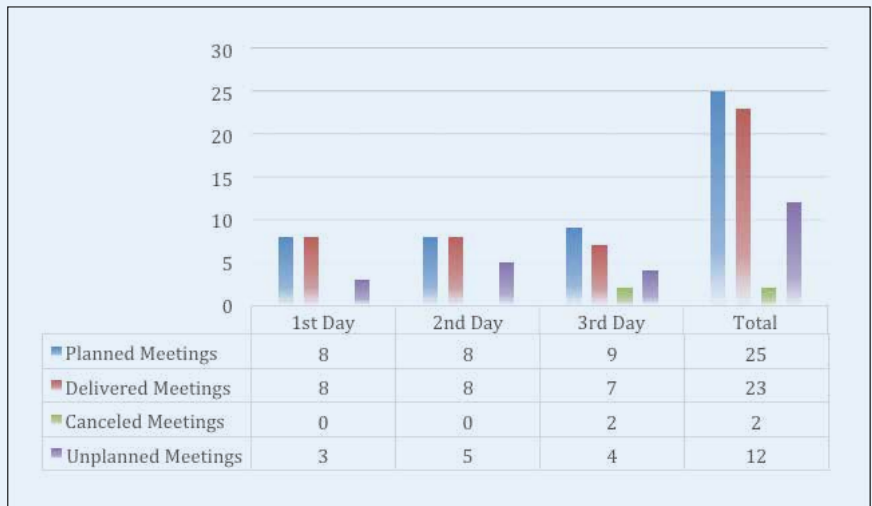

Figure 1. Meetings statistics of Istanbul Fellowship Program

What does the program provide?

The applications submitted to the Istanbul Fellowship Program were evaluated by TBYM Assessment Board in November 2019. The successful applicants were provided with three different support packages: Golden Support Package, Silver Support Package, and the Bronze Support Package.

Participation Benefits

- Introducing QU Press among the international presses and sectors of the participating countries.
- Meeting and exchanging experiences with international academic presses.
- Exchanging publishing and translation rights. The exchange

opportunities have been discussed during the 3-day meetings that were held on the sidelines of the Program.

- Opportunity for initiating contracts and expansion with external distribution points. In this regard, meetings were held with many distributors from inside and outside Turkey.
- Identifying several printing companies, which will contribute to facilitate the printing of QU Press future projects.
- Attracting and meeting many international presses without any prior appointment.
- Attending the workshops, which were organized during the days of the Program. These workshops were focused on the importance of the Press participation in international events and the importance of buying and selling multilingual publishing and translation rights.

Meetings

A meeting was held with several international presses from 11 countries including Turkey, Malaysia, Russia, the United States of America, the United Kingdom, Ethiopia, Zambia, Greece, France, Pakistan and The Islamic Republic of Iran (Figure 1).



Part of the 5th Istanbul Fellowship Program

QU Research and COVID-19 Pandemic

Qatar University stands side by side with all research and health institutions in the State of Qatar to address the threat of the emerging Coronavirus (COVID-19). The University has made a set of precautionary decisions to protect the safety of its employees. At the same time, efforts are made to support research and researchers in colleges and the research sector to develop methodologies and the outputs of scientific research, and to enhance effective participation with all state institutions in order to protect the Qatari society.

On the Emerging Coronavirus COVID-19, which invaded the Entire World and pushed it towards a Global Red Alert, we spoke to

Dr. Asmaa Al Thani, Director of Biomedical Research Center at Qatar University

Dr. Asma is distinguished academically and administratively and has held many positions at Qatar University and specialized in the study of medical virology from the University of London. She is currently Director of the Center for Biomedical Research, Board Vice Chairperson of the Qatar Biobank for Medical Research, and Chairperson of the Qatar Genome Program Committee, members of the Qatar Foundation.

We took to her the following queries:

Dr. Asmaa, would you please brief us about the emerging Coronavirus (COVID-19) pandemic?

The emerging Coronavirus (COVID-19) is an extension of the Coronavirus family of animal origin that has the ability to cause multiple mutations that gives it the ability to infect humans. Previously, the matter was limited to the SARS syndrome in 2003 and the MERS syndrome in 2012. The spread of infection at that time between animals and humans was limited, but now with COVID-19 this has varied due to the very rapid spread of the virus between humans in a manner similar to the rapid spread of measles in some societies.

How does this virus evolve? What are the factors that help in its development?

Viruses appear year after year due to their ability to adapt to the surrounding conditions and cause mutations in which they attack the human immune system, which therefore cannot recognize the viruses in their new form. Therefore, antibodies that our bodies have formed against the previous virus lose their importance.

Among the environmental factors that provoke and increase viruses are increasing population density, climate changes, ease of movement and travel, and the habits of some peoples in coexisting with animals or living near them, in addition to not

adhering to the rules of hygiene, especially during cooking and storing foods.

What is the reason for the rapid spread of the COVID-19 virus?

Viruses spread by causing mutations in the receiving area of the target cell in a person, and try to infect more than one cell in the human body, such as the cells of the respiratory system, eye cells, and the digestive system. Some viruses have this ability, which makes them more prevalent among people in society such as the COVID-19. Others are limited such as SARS.

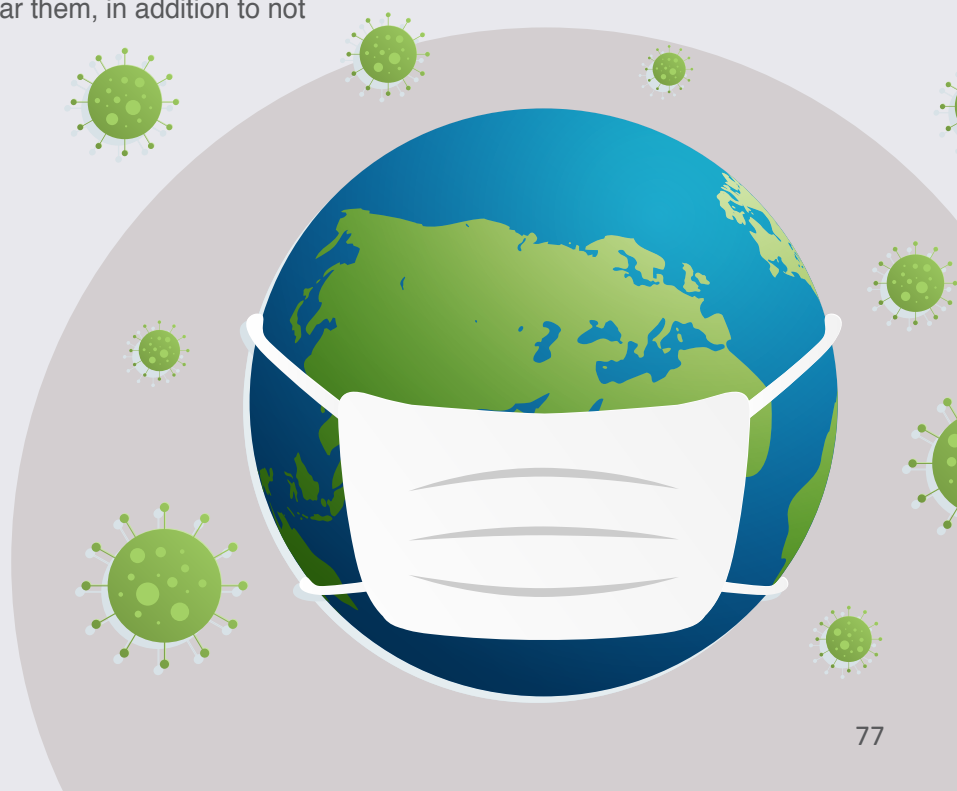



Photo showing Biosafety Level-3 (BSL-S)

In your opinion, is it the fear and panic felt towards COVID-19 virus that is dominating the world apposite?

Being moderate in tackling this subject, without excessiveness on the one side or negligence on the other, is the right course to take. Excess fear and panic directly affects a person’s immunity, and negatively affects his productivity, especially if this person is a leading figure at his work or his family. He is required to be a positive model, especially as the statistics declared to date by the World Health Organization reveal that the cure rate is high, between 85-95%.

What is the role of the Center for Biomedical Research under the current conditions?

The Center for Biomedical and Medical Research contains a laboratory that corresponds to the third level of biosafety of BSL-3 laboratories that provide safety factors when dealing or treating infectious, self or foreign factors that are transmitted by inhalation and can cause serious illness. This includes the emerging COVID-19 virus. For that reason, the Center researchers, under the current conditions, in cooperation with researchers from inside and outside the University are conducting several researches and studies on emerging viruses, including a “detailed study of cases infected with COVID-2019.”

This is carried out in cooperation with the Faculty of Medicine at Qatar University and the Ministry of Public Health – Qatar. The Center has also conducted a study on “the use of digital simulation technology to test the ability of some inhibitors to stop the COVID-19 being connected to cellular receptors.”

Shall we expect soon in the future a treatment or vaccine for the emerging Coronavirus (COVID-19)?

There are several attempts happening now, some of which have started laboratory and clinical experiments after obtaining the approval of the Food and Drug Authority in the United States of America. Thus, they register shorter time in devising the vaccination (only two months) compared to the 20-month SARS vaccination. Since viruses multiply in cells, they use many of the same mechanisms that our cells use. It has been thus difficult to find drugs that target the virus while not causing harm to the cell too.

Are global efforts to fight COVID-19 feasible?

Each country’s experience differs from the others, in my opinion. To date China is a typical example in containing the crisis as it has huge industrial capabilities, in addition to the experience of South Korea and Singapore, which are good models. They

have relied on reducing social communication to reduce transmission and number of patients who may need intensive care at the same time. We are also witnessing America’s experience of engaging the private sector to take part of the responsibility. As for the British experience, it is a bold one that adopts the theory of injuring 60% of society to raise its immunity.

Being an expert in this science, what are the precautions against infection with this virus?

Our references in this matter should be WHO recommendations and guidelines. Their application, however, in countries and being committed to them vary from one country to the other, as many of them depend on human behaviors such as washing hands with soap and water well, or having some capabilities such as avoiding crowds and human density in small places.

How can we reassure the Qatari community? What do you recommend?

The State of Qatar is considered one of the most flexible and proactive countries in dealing with this pandemic in general. For example, it is at the forefront of countries that sought to obtain the examination quickly and in sufficient quantity, which is reflected in the large number of examinations that have been conducted so far, that exceeds many countries. For example, the number of deaths in some countries, such as Italy, gives a clear indication that the number of examinations was insufficient.

It is enough for the people to be reassured that the Supreme Committee for Crisis Management for Combating COVID-19 is carrying out its tasks under the guidance of good leadership. May God protect everyone and protect our dear homeland.

How could artificial intelligence aid in the fight against coronavirus?

Interview with Dr. Hadi Yassine Manager of Research Projects at the Biomedical Research Center

A research paper was issued by the Journal of Experts Review of Anti-Infection Therapy, and was published on March 29, 2020. It included an interview conducted by the Editor, namely Felicity Paul with Dr. Hadi Yassin, Manager of Research Projects, Associate Professor of Infectious Diseases at the Center for Biomedical Research at Qatar University and Dr. Zubair Shah, Assistant Professor, Department of Information and Communications Technology, College of Science and Engineering, Hamad Bin Khalifa University, Qatar. The title of the paper reads: "How could artificial intelligence aid in the fight against coronavirus?".

Here we highlight Dr. Hadi Yassin's opinion over the questions posed in the research paper, funded through the Qatar University Grant # QUCG-BRC-20 / 21-1.

Do you believe that artificial intelligence (AI) is the key to a cure for the Coronavirus?

Artificial intelligence (AI) is one of the means or avenues to understand the virus and develop preventative and

control measures. This includes but is not limited to the usage of mathematical modeling to understand virus transmission, structural biology to determine virus structure and develop vaccines, computational biology to understand virus evolution, as well as docking studies to screen for drugs and inhibitors.

What is in-silico screening, and why is it particularly important in the case of Coronavirus outbreak?

Screening for anti-viral drugs can be done using one of the two main methods: Either using an in vitro system (cell culture) to robotically screen for thousands



of compounds that can inhibit virus growth; or utilizing a solved viral protein structure and specific computer programs to screen for drugs that can bind the viral proteins (typically an active domain) and potentially inhibit the virus replication. Still, predicted anti-viral drugs must be tested *in vitro* and *in vivo* before testing them in clinical trials.

How can techniques such as artificial intelligence and in-silico screening be applied to vaccine development for COVID-19?

A vaccine can be developed using different approaches, one of which is structure-based vaccine

development. Previously, scientists used to grow the virus in cell culture or animals, then chemically inactivate it and used it as vaccine. Such treatment could alter the nature of the virus, which might induce wrong antibody responses and could

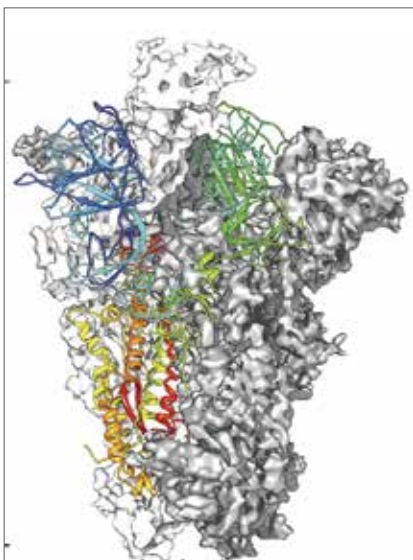

The outer protein of the Coronavirus used to develop a vaccine

source : <https://science.sciencemag.org/content/sci/367/6483/1260.full.pdf>

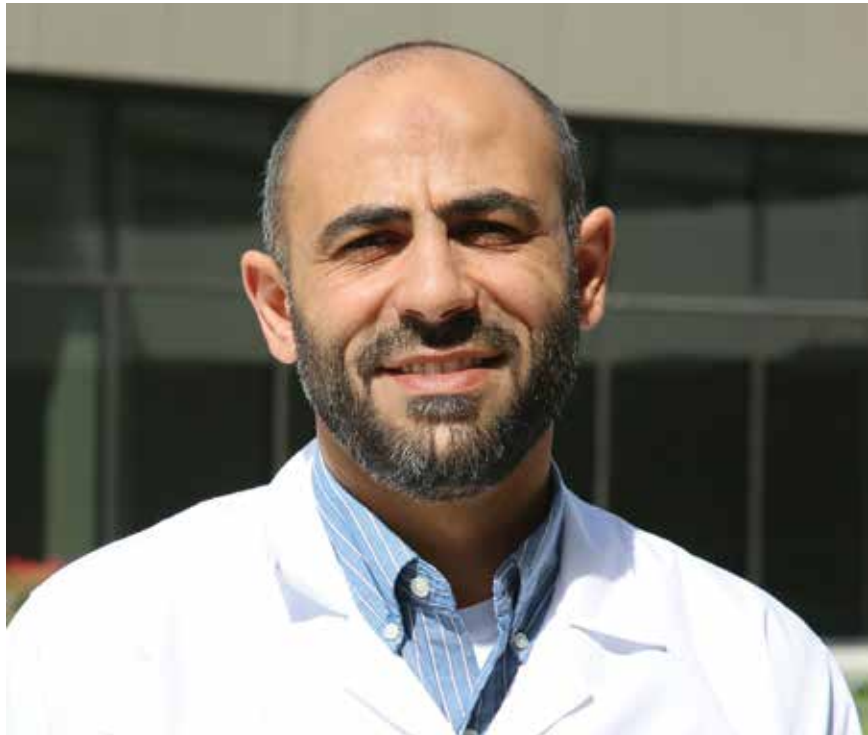

Dr. Hadi Yassin

cause more harm than good. To induce appropriate immune responses, i.e. antibodies that can neutralize the virus, we must first understand the target of these antibodies on the virus. This could be partially achieved by understanding the structure of the viral proteins, typically the surface ones that are used by the virus to bind and infect cells. Solved structures will reveal the characteristics of the antigenic sites and functional domains on the surface of glycoproteins (spike protein in case of coronaviruses). Such information could help in designing a stable protein (or a protein subunit), which could then be mounted on a specific platform (nanoparticles) to be used as a vaccine.

How has monitoring and surveillance of disease outbreaks changed in recent years, and what does this

mean for disease modeling?

According to some reports, more than 50% of emerging or reemerging infectious diseases are of zoonotic origin; i.e. transmitted to humans from animals, either directly or through intermediate hosts. This includes avian influenza, SARS/MERS/SARS-2 Coronaviruses, Nipah virus and many others. Such pathogens are now being investigated using what we call “one health approach”; i.e. at the human-animal environment interphase. Accordingly, viruses are surveyed and studied in their natural hosts, whether in birds in the cases of influenza viruses, or in bats in case of Coronaviruses. These viruses might not be 100% identical to those isolated from humans, however, sequence analysis can help in identifying factors that contribute to virus transmission from one host to another. For

example, you can compare the sequence of the virus in human to that in a bat to determine the differences in certain functional sites (e.g. receptor binding domain, protease cleavage sites and others) that could influence virus transmission.

What is the relevance of artificial intelligence and big data analytics in situations such as the recent Coronavirus outbreak, and how can they help us prepare for future viral outbreaks?

It is proposed that every 100 years, a major pandemic will occur and claim the lives of thousands if not millions. In 1918, a major influenza pandemic (Spanish flu) resulted in the death of about 50 million people globally. Now, we are facing another pandemic with the SARS-2 Coronavirus. Can these pandemics be predicted? Maybe! Predicting when such a 'zoonotic' disease will initiate an outbreak remains challenging; however, some studies suggests that A.I. could play a role in this regard. Using mathematical modeling, researchers were able recently to pinpoint, with 90% accuracy, the rodent species that are known to carry pathogens that can transmit to humans. A more complex algorithm may be used to predict the underlying dynamics of virus evolution and immune response to viral changes. For example, computation biology has been used to study HIV evolution in single patients, as well as the parallel evolvement of antibody responses to the virus in the elite controllers: 'are a group of people living with HIV who spontaneously control HIV viral load below the limit of detection for long periods of time

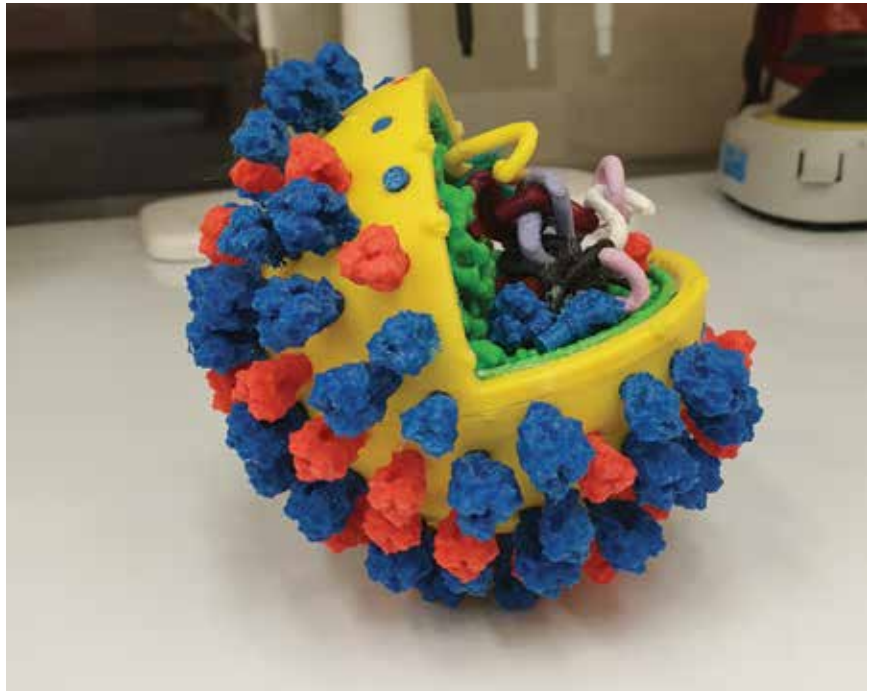

Three-dimensional model of a virus that infects the respiratory system

in the absence of antiretroviral therapy'.

How has social media influenced the recent Coronavirus outbreak, and can it be used to benefit public health?

Social media is a double-edged sword. Still, international organizations (the WHO and others), local institutions (ministries) and individual scientists have been trying their best to deliver the correct information.

What are some of the downsides of using artificial intelligence and what are some of the challenges around data protection?

For the most part, A.I. findings must be validated in the lab as well as in animals. Furthermore, whatever works in animals will not necessarily work in humans. Accordingly, vaccines and drugs are initially tested

(Expert Review of Anti-infective Therapy 3) in mice followed by none-human primates before testing in humans. In humans, drugs and vaccines are tested in different phases of clinical trial to evaluate safety, immunogenicity and efficacy.

What do you think the next decade holds for the use of artificial intelligence in your research fields?

It is hard to answer this question at this point. In my lab, we focus mostly on wet lab work more than A.I. Still, we do use A.I. in various fields, including, virus evolution (influenza and Coronaviruses), docking studies to find anti-viral drugs, and modeling of mutations that can influence vaccine efficacy (e.g. rotavirus). This field is still very much in its infancy in the State of Qatar, and we need to do a lot in terms of capacity building before we can achieve high levels of performance.

(SESRI) - (QU) Conducts Survey on Coronavirus (COVID-19)



Prof. Hassan Al-Sayed
Director of Social and Economic Survey
Research Institute - Qatar University

The Social and Economic Survey Research Institute (SESRI), a social scientific survey research initiative of Qatar University, surveyed 2,131 individuals, including Qatari nationals, white-collar and blue-collar expatriates about the Coronavirus (COVID-19) outbreak. The survey started on 12 March until 14 March 2020.

The survey is based on a nationally representative sample interviewed by telephone in ten different languages. SESRI interviewers collected answers in the short survey that revealed both Qataris and resident expatriates to be very aware of the Coronavirus (COVID-19) and concerned about its possible impact.

The Coronavirus (Covid-19) Quick Poll

The majority of Qatari nationals, white-collar and blue-collar expatriates are well aware of the Coronavirus.

Overall, the vast majority of Qatari nationals, white-collar and blue-collar expatriates are well aware of the Coronavirus (COVID-19). Moreover, 97% of Qatari nationals, 94% of white-collar and 87% of blue-collar workers said they have heard or read some or a lot about the Coronavirus outbreak. Qatari nationals (84%) and white-collar expatriate workers (79%) were more likely to say that they have heard or read a lot about the Coronavirus as compared to blue-collar expatriate workers (56%). The respondents were given the following questions to answer (Figure1).

Television, Twitter, Facebook, and word of mouth are the most frequently mentioned main sources of information about the Coronavirus pandemic. For



During data collection in SESRI's Call Center

How much, if anything, have you heard or read about the recent Coronavirus outbreak?

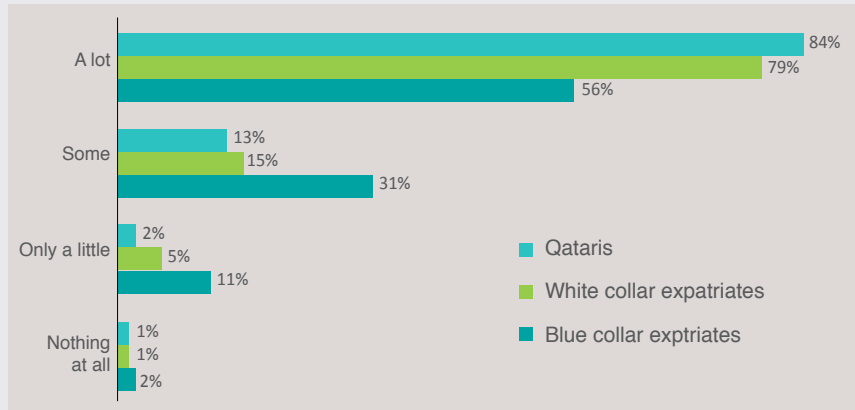

Figure 1. Results of a survey on the extent of knowledge of citizens and residents of the Coronavirus

Qataris, television (31%) and Twitter (18%)

are the most mentioned main sources of information, while for white-collar expatriates, television (23%) and Facebook (20%) are the main sources of information. Facebook (31%)

and word of mouth (23%) are mentioned as the main sources of information about the Coronavirus outbreak for blue-collar expatriates. Other sources of information for respondents include other social media platforms, newspapers, and the

Ministry of Public Health (MOPH) (Figure 2).

The majority of Qatari nationals, white-collar and blue-collar expatriates are concerned about the negative impacts of the Coronavirus.

Qatari nationals (62%), white-collar (71%) and blue-collar expatriates (74%) in large numbers said they are either very or somewhat concerned that the Coronavirus will have a negative impact on the economy of Qatar. Blue-collar expatriates (46%) are significantly more likely to be very concerned, as compared to white-collar expatriates (36%) and Qatari nationals (28%). Overall, Qataris are least likely to be concerned about the negative impact of the Coronavirus on the economy of Qatar (Figure 3).

All respondents were asked about their level of concern about a possible widespread

What is the main source of your knowledge about the Coronavirus?

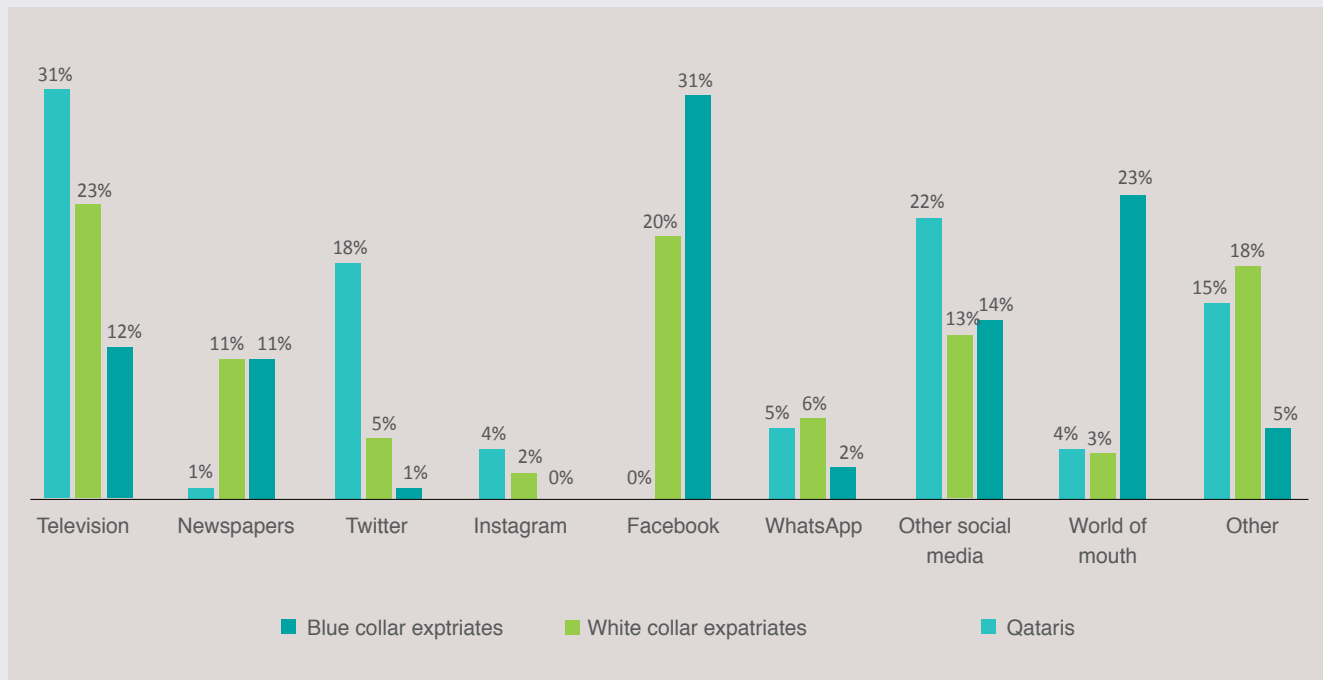

Figure 2. Results of a survey of sources of information on the Coronavirus

outbreak of the Coronavirus in Qatar. Nearly two-thirds of all respondents reported being somewhat or very concerned (62% for Qataris; 65% for white-collar expatriates; and 68% for blue-collar expatriates). Once again, blue-collar expatriates (40%) were more likely to be very concerned as compared to Qataris (31%) and white-collar workers (33%) (Figure 4).

With regard to the respondents' level of concern about themselves or someone in their family falling sick due the Coronavirus, all groups expressed concerns (76% of Qataris, 73% of white-collar expatriates, and 67% of blue-collar expatriates). Overall, Qatari nationals (76%) were more likely to be somewhat or very concerned in comparison to blue-collar expatriates (67%) (Figure 5).

In general, women reported higher levels of concern about a possible widespread outbreak of the Coronavirus in Qatar, and even more so about the possibility that they or their family members might contract the virus. Similarly, younger respondents were more likely to be concerned about the negative impact of the Coronavirus on the economy of Qatar, its widespread outbreak, and the possibility of themselves or their family members contracting the virus.

While blue-collar expatriates said they know less about Coronavirus, they expressed more concern about its effects on the economy and about the potential for an outbreak. This suggests that their lack of access/exposure to information may be driving their concern, and that providing more accurate information might reduce their

How concerned, if at all, are you that the Coronavirus will have a negative impact on the economy of Qatar?

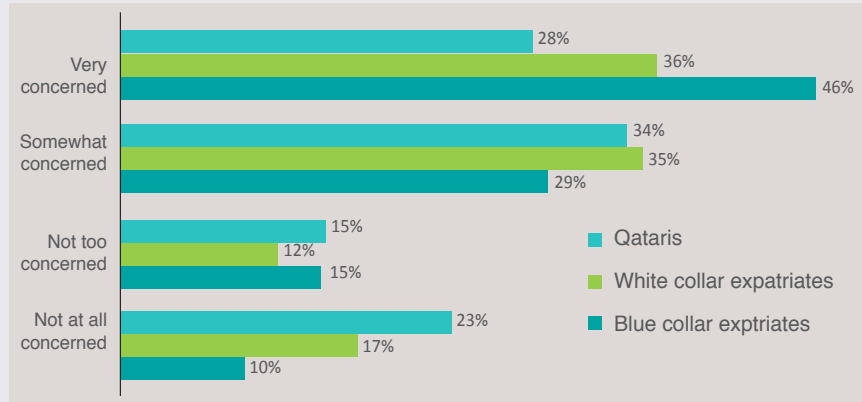

Figure 3. Results of a survey of the extent of concern regarding the negative impacts of the Coronavirus on Qatar's economy

level of worry.

Washing hands regularly and using hand sanitizers are the most mentioned precautionary measures taken by all respondents to protect themselves and their families against the Coronavirus.

While all groups of respondents mentioned washing hands regularly and using hand sanitizers, blue-collar workers

were more likely to mention washing hands regularly as a precautionary measure (84%), as compared to white-collar workers (76%) and Qataris (67%). However, blue-collar workers (46%) were least likely to report using hand sanitizers as a precautionary measure (vs 68% for Qataris and 62% for white-collar expatriates). This is, presumably, because they have less access to hand sanitizers.

How concerned, if at all, are you that there will be a widespread outbreak of the Coronavirus in Qatar?

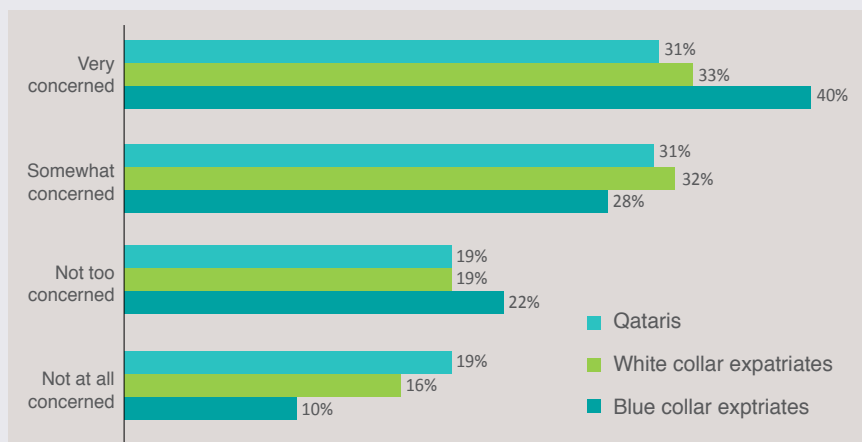

Figure 4. Results of a survey of the extent of concern about the possibility of Coronavirus spread in the State of Qatar

About half of Qataris (49%) and white-collar expatriates (54%) and slightly less than half blue-collar expatriates (42%) also mentioned avoiding public places such as malls, mosques, and shopping centers. Similarly, 50% of Qataris, 40% of white-collar and 39% of blue-collar expatriates said they avoid public gatherings including majlis, weddings, funerals, and friday prayers. Interestingly, nearly two-thirds of blue-collar expatriates (66%) said they use protective masks as compared to 29% of white-collar expatriates and 13% of Qataris. Blue-collar expatriates, due to the nature of their living and workplace environment, are more likely to interact with crowds of people. Other precautionary measures implemented by the respondents include avoiding handshakes, kissing on the forehead, nose, and cheeks.

Acknowledgement by Prof. Hassan Al-Sayed, SESRI Director

Prof. Hassan Al-Sayed, Director of the Social and Economic Survey Research

Institute (SESRI) highlighted the importance of this survey at this particular point of time. The survey identifies the extent of awareness about the Coronavirus (COVID-19) and precautionary measures taken by Qatar’s citizens and residents. Prof. Hassan added, “Surveys of this kind inform policy and decision-makers about the public’s feedback and this helps in mitigating this pandemic.” He expressed thanks to all those who participated in the survey, which was conducted through the Institute’s Call Center.

The Social and Economic Survey Research Institute (SESRI), a social scientific survey research initiative of Qatar University, was established in October 2008 with enthusiastic support from the leadership of Qatar University. SESRI’s mission is to provide sound and reliable data to guide policy formulation, priority-setting, and evidence-based planning in the social and economic sectors.

The Institute’s research

agenda spans a wide range of substantive areas of importance to Qatari society, including labor and employment, modernization and shifts in social values, education, health, family structure, and the impact of social and traditional media. At the same time, SESRI works to place results from Qatar into a wider context through participation in regional and international survey projects, including the widely utilized World Values Survey.

The Institute has assembled a highly qualified staff with diverse research interests, a wealth of professional experiences, and, above all, a shared vision and commitment to the importance of conducting high quality survey research that serves people. Indeed, the core values guiding our work are independence, public service, cooperation with existing research initiatives, and transfer of knowledge and skills to build the capacity of the next generation of young Qatari social science researchers.

SESRI conducted this Coronavirus Poll via telephone with 2,131 respondents including Qatari nationals (726), resident white-collar (750) and blue-collar expatriates (655) aged 18 years and older. The survey was fielded between Thursday March 12 to Saturday March 14, 2020, with a response rate of 50.7 percent and a maximum sampling error of +/- 3.2 percentage points. The calculation of this sampling error takes into account the design effects. The final dataset was weighted to adjust for probability of selection and non-response. SESRI thanks everyone who participated to ensure that public opinion would be fairly represented.

How concerned, if at all, are you that you or someone in your family will get sick from the Coronavirus?

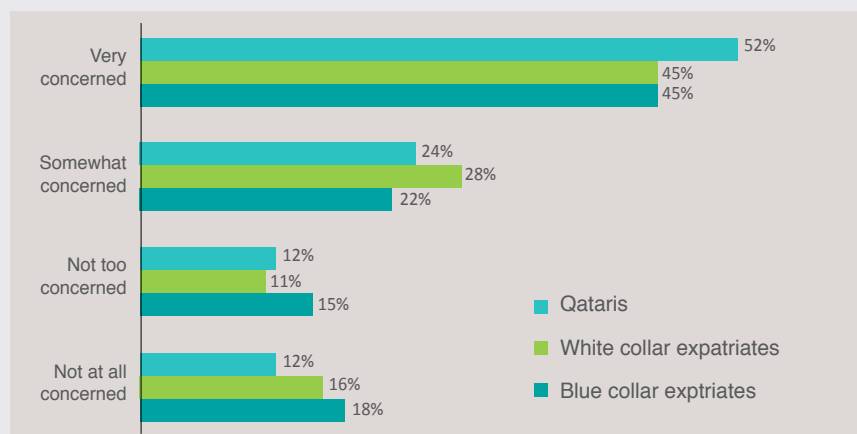

Figure 5. Results of a survey on the extent of concern about you or any of your family members catching the Coronavirus

COVID-19 Serology Screening ELISA Test and Potential Vaccine Candidate Development

Dr. Susu Zughaier

Associate Professor of Microbiology and Immunology,
College of Medicine - Qatar University



Dr. Susu Zughaier

About the project, Dr. Susu says:

This project is in collaboration with my colleague Dr. Michail Nomikos and BRC research team (Dr. Hadi Yassine, Dr. Asmaa Al-Thani and Dr. Gheyath Nasrallah), Computer Sciences (Dr. Sumaya Al-Maadeed and Dr. Muhammad Chowdhury), and our collaborator Dr. Ali Ait Hussain at Hamad General Hospital.

The ongoing COVID-19 pandemic requires rapid diagnostic test to detect infection with SARS-CoV2. Serological test detects antibody response and seroconversion of infected patients or asymptomatic subjects, who are exposed to the virus. Upon exposure to infection, human body produces specific antibodies that prevent virus from adhering or infecting other

host cells. Serology test should help in detecting seroconversion of COVID-19 patients, which is very helpful in determining the level of neutralizing antibodies. Identifying subjects with high neutralizing antibodies will be essential in preparing convalescent serum therapeutics. To do this test we will use a bacterial expression system to produce SARS-CoV2 RBD as recombinant protein in vitro, which will be used as the capture antigen for the serology ELISA to detect and quantitate patients' serum titers of anti-SARS-CoV2 specific antibodies.

Furthermore, RBD protein has been shown to be immunogenic and to induce potent neutralizing antibodies, thus it can be considered as a promising vaccination option. We will use the human in vitro MIMIC system to assess the immunogenicity of the RBD antigen with the proper antigen presentation and optimal adaptive immune responses. RBD vaccine antigen formulation can be prepared using nanotechnology



Prof. Serhiy Souchelnyskyi

microparticle to encapsulate the antigen and deliver it using dissolvable microneedle skin patch.

The main goal of the proposed study is to expedite the development of an in-house rapid serology test for COVID-19 that could be used to screen subjects when needed at HMC, PHCC and the community in Qatar in situations of emergency and crisis. The prototype is serology diagnostic test based on ELISA method. This diagnostic serology is part of capacity building at QU and that aims to develop rapid diagnostic serological test to screen for COVID-19 infection in case of supply chain shortage.

“I do have considerable expertise in developing nano-vaccines delivered by skin-patch dissolvable microneedles”, says Dr. Susu. “Therefore developing a nanotechnology based vaccine formulation against COVID-19 would serve as enabling a platform to build cutting-edge research as part of

capacity building at QU.”

Prof. Serhiy Souchelnyskyi, College of Medicine, QU

Project #1: COVID-19 and Cancer: Unveiling links by Omics.

About the project, Dr. Serhiy says:

This project is to elucidate how COVID-19 may affect cancer in a patient who got infected with the virus. This is of importance for the assistance of clinicians in helping cancer patients infected with COVID-19.

When a cancer patient is infected, the virus influences how doctors may treat the patient. For example, some treatments would be postponed, and some modified, novel treatments may be added. “My project is to unveil markers

helping doctors to take the right decision,” says Dr. Serhiy.

The goal of the project is to identify markers which would help a doctor to select the right treatment for a cancer patient infected with COVID-19.

‘Currently, I have already performed a collection of data and a systemic analysis. Cancer-relevant regulatory mechanisms have been identified. More than 70 markers have been selected. Now, these markers have to be validated with different research methods. The validation step is crucial to ensure the robustness (quality) of the markers. I expect that at the end we may have 10-20 markers, as a panel. This panel will be then taken for clinical trials.

In this project, I use approaches developed in Cancer in the Space Project and Technologies at the QU Proteomics Core facility and QUSearch platform,’ Dr Serhiy adds.

Collaborators: National Center for Cancer Care and Research, Interim Translational Research Institute of Hamad Medical Corporation, and Hamad bin Khalifa University; all in Doha, Qatar. International: Karolinska Institute, Stockholm, Uppsala University, Oranta Cancer Diagnostics AB, Uppsala, Sweden; Lviv National Medical University, Institute of Cell Biology, Institute for Space Research, Lviv, and Pustomy Regional Hospital, Ukraine; ICE Cube Space Application Services, Noordwijk (European Space Agency), EU.

Project #2: Development of COVID-19 detection kit, based on PCR.

To develop a PCR-based kit for the detection of COVID-19 is a very practical work to do. I have developed many tests for cancer patients, and the same technology was used for the virus detection kit.

The test has been developed. It can detect COVID-19 and discriminate it from MERS and SARS, by using model systems. MERS and SARS are very similar viruses but are not as dangerous as COVID-19.

Currently, the test is being prepared for clinical testing, with patients. This should be done at hospitals certified for working with live viruses. In addition, this is what is currently under discussion, e.g. implementation of the kit in the clinical practice.

There are many commercial kits available these days. One can ask why to develop another one. To have in-house technologies needed for the development of such kits allows timely and efficient response with testing of mutated versions of the virus.

There are reports that COVID-19 has different forms, from 2 to 5, with different severity of the symptoms/

disease. If one has a test kit technology in-house, one can help doctors and patients much better and faster.

The current goal is to transfer the kit into clinical laboratories.

Collaborators: as this is a very technical project, the main collaboration was done with Oranta Cancer Diagnostics AB and Pustomy Regional Hospital, Oncology Department, Ukraine. To transfer the kit to a clinical laboratory, we hope to attract interest at Hamad Medical Corporation (HMC), and in Qatar in general. The government reacted forcefully and in time, as we can see, all required resources are provided, including kits for detection.

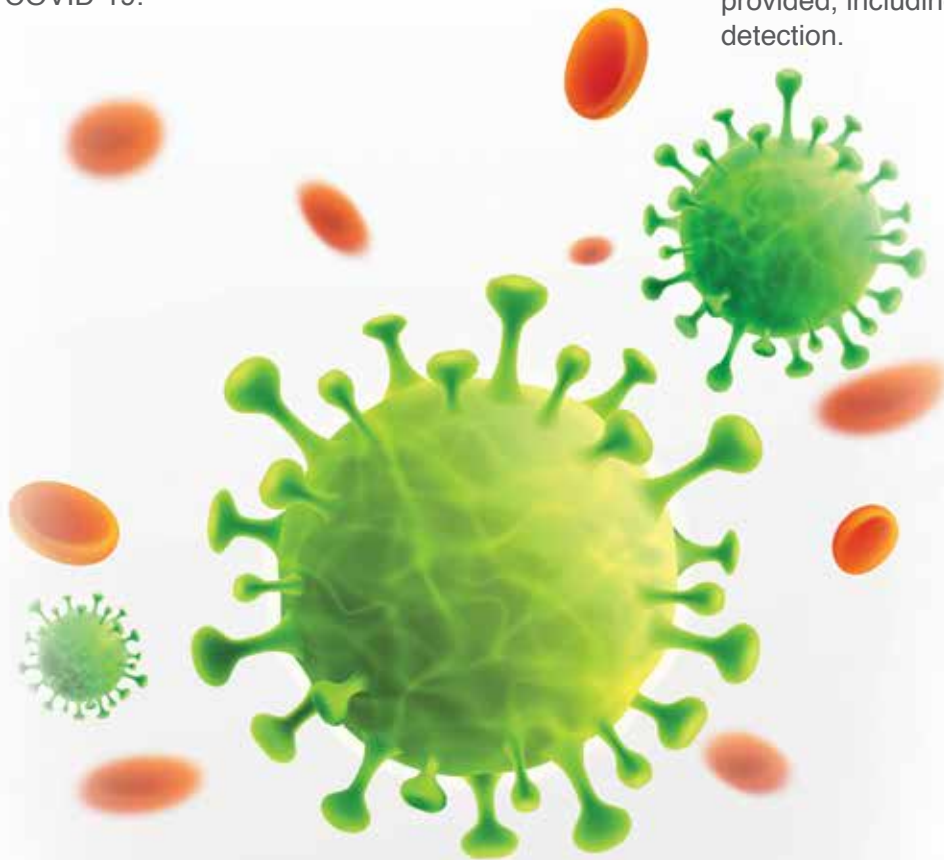

e-Health at Qatar University and COVID-19

Prof. Tamer Khattab

Professor of Electrical Engineering, College of Engineering-Qatar University



Prof. Tamer Khattab



The research on e-Health has been ongoing at Qatar University for more than 7 years now, relying on internal University funding, external funding through the national priorities program funded by Qatar National Research Fund (QNRF) and via partnership with Hamad Medical Corporation and Al-Ahli Hospital. Most of the research has focused on two main streams: (i) remote health monitoring and (ii) digital health systems. While research on remote health monitoring has focused on increasing energy consumption efficiency, enhancing communication performance

and security; research on digital health systems has focused on connected medical records, artificial intelligence based diagnostics and simulation based medical training.

With the onset of the COVID-19 pandemic, research efforts worldwide and at Qatar University, including the e-Health research, have shifted focus to providing solutions to fight the pandemic. Relying on their previous expertise and impactful outcomes, e-Health researchers at Qatar University have directed their attention to the COVID-19 pandemic-related

research activities. The relevance between e-Health and COVID-19 stems mainly from the fact that remote health monitoring and artificial intelligence based diagnostics provide key solutions to the problem of overload on the health system due to surge in number of cases requiring medical attention because of the rapid infection rate of COVID-19.

As part of the contribution to the fight against COVID-19, e-Health research teams at Qatar University have already started many initiatives. Some examples are:

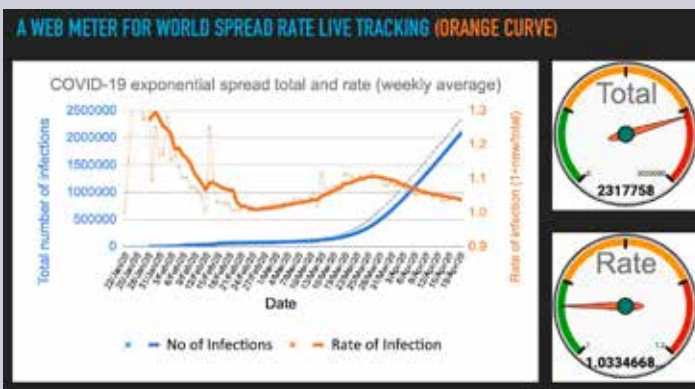

Figure 1. A simple COVID19 webpage

1 - A simple COVID-19 webpage, which enables tracking the total number of confirmed cases and the infection spread rate worldwide and in Qatar using official data from Ministry of Public Health. The page also provides simple key information on how to interpret the statistics and some information on major worldwide progress on treatment/ vaccination activities (Figure 1).

2 - A web-based prediction system for pandemic focal geolocations, that collects simple survey data from users to predict focal point of infection spread and inform this to the medical authorities to prepare for optimal locations of field hospitals and field tests.

3 - The first COVID-19 Arabic Twitter dataset, is established through analyzing Arabic tweets

that mention COVID-19 and groups them according to time and location categories as well as applying more advanced data analytics. Some of the interesting findings were the relation between time of the first tweets about COVID-19 from a certain city/country and time of the official announcement of first case of COVID-19 in the same city/country. This provides another key resource for data to support decision-making (Figure 2).

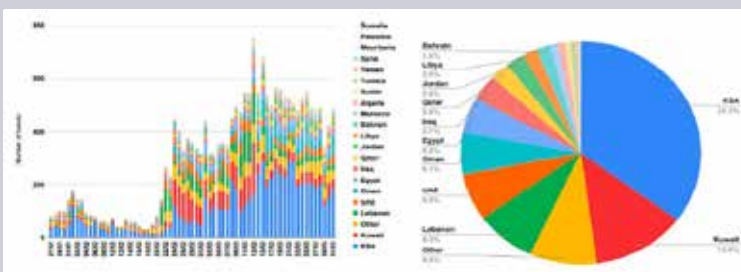

Figure 2. The first COVID19 Arabic Twitter dataset

4- A simulator for extracorporeal membrane oxygenation (ECMO), which is used to train medical and nursing staff to attach the ECMO to the body of the patient in the right way without having to try on an actual patient. The

process itself is very delicate and requires several training sessions before the medical staff can master it. The process is needed to save lives of COVID-19 3rd stage patients (Figure 3).

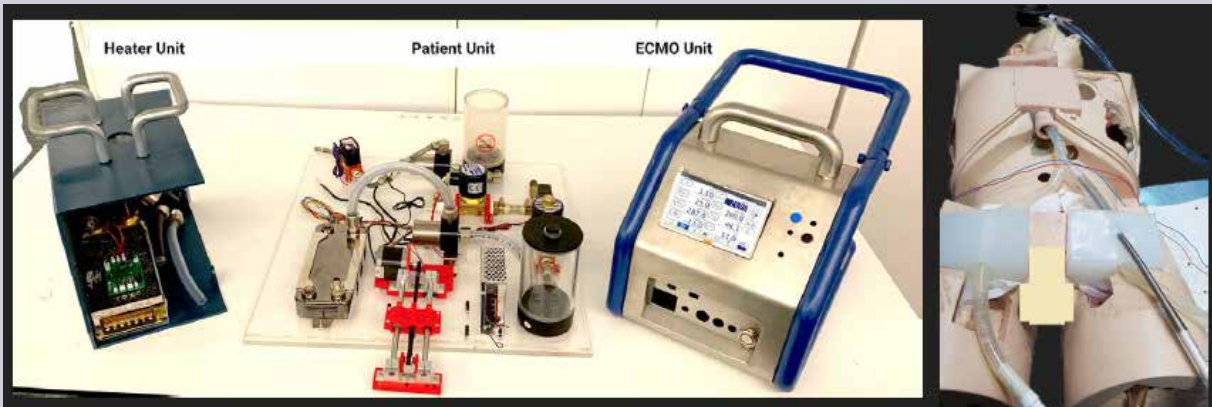
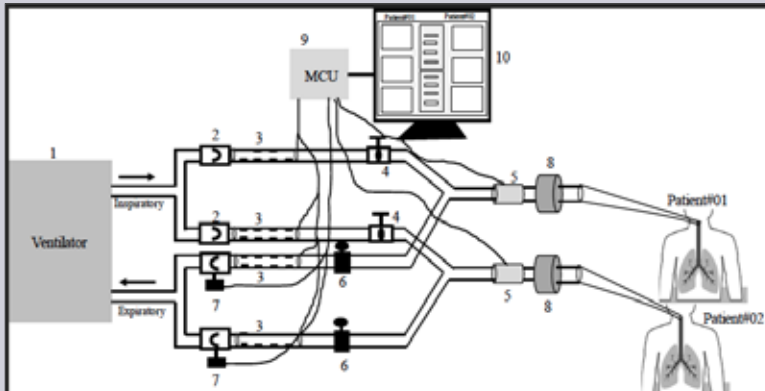

Figure 3. A simulator for extracorporeal membrane oxygenation (ECMO)



5- Dynamic ventilator circuitry divider, used to enable sharing of the same ventilator main device between multiple patients, which guarantees protection against infection as well as efficient delivery of oxygen as per the need for each individual. This reduces the number of required ventilators per certain number of patients. The device has been developed as a joint effort between Qatar University and Hamad Hospital (Figure 4).

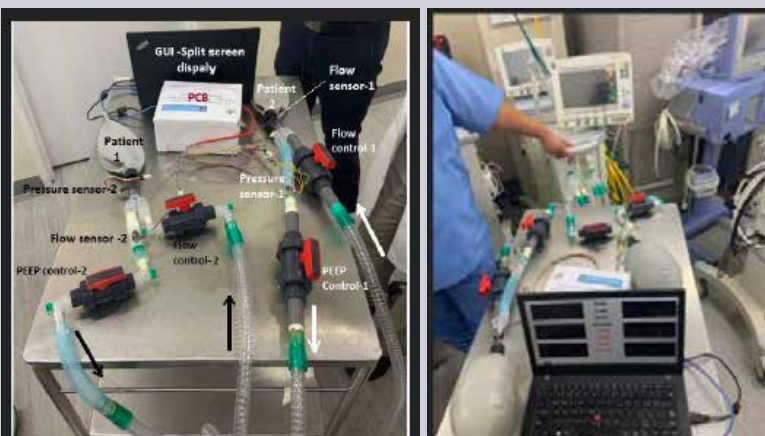

Figure 4. Dynamic ventilator circuitry divider

Qatar University continues academic activities despite COVID-19 challenges

Distance Learning and Working

Through its website, Qatar University has provided sources of distance learning for the continuation of the education process for its students, remote work e-programs and training workshops for its employees. It also uses the best evaluation practices in the distance learning and work environment during the COVID-19 pandemic in order to maintain the safety of students and employees. The Office of the Vice President for Research and Graduate Studies has conducted extensive training workshops for e-work, especially through the Microsoft Team program for its staff, to enhance their capabilities and ensure the effectiveness of

remote work and compliance with the instructions of the Supreme Committee for Crisis Management in Qatar.

Electronic Seminars and Conferences

Qatar University uses online platforms to hold distance seminars and conferences, including the “COVID-19: Challenges & Perspectives” Conference on the Webex platform, which was held by the Research and Graduate Sector on Sunday, April 19, 2020, with the participation of elite experts and researchers from various disciplines. The conference featured a number of specialized

sessions bringing together experts from Qatar University and beyond. A number of important issues were addressed including challenges of the COVID-19 testing; the community’s knowledge about the pandemic; role of social distancing in limiting its spread, e-health, in addition to the impact of Coronavirus on the economy, and recommendations and directions to overcome this crisis with the least possible losses. The Research Sector also started a series of direct dialogue interviews via Live Instagram with a number of experts at Qatar University, the first of which was a dialogue on post-Corona knowledge-based economy on April 20, 2020.

On Sunday, April 26, 2020, the Office of Innovation and Intellectual Property in the Research and Graduate Studies





Sector presented an e-seminar titled “Intellectual Property, Innovation and Overcoming the Novel COVID-19 Crisis” attended by a number of specialized experts from Qatar University, the Ministry of Commerce and Industry and the Qatar Science Club. During the seminar, participants discussed the role of the IP rights in enabling scientific research in the face of crisis, the role of Department of IP Protection in the country to counter the Corona pandemic and the facilities provided to businesses in Qatar. This was in addition to a discussion session on developing and producing national innovations to overcome

the COVID-19 crisis.

Discussion of Master’s and Doctoral Theses

On Wednesday April 22, 2020, a scientific thesis for a master’s degree in civil engineering was defended through the e-learning platform using visual communication technology via the WebEx Productivity Tools at the Center for Advanced Materials (CAM), Qatar University. The graduate student Mohamed Rabie, from the Department of Civil Engineering defended his thesis under the supervision of Dr. Mohammad R. Irshidat (Advisor) from CAM and Dr. Nasser Al-Nuaimi (Co-Advisor), Director of

CAM. The thesis was entitled: “Factors Influencing the Mechanical Properties of Geopolymer Mortar made of Fly Ash.”

The thesis committee consisted of Dr. Mohammad R. Irshidat’ (Supervisor and Chairman), Dr. Wael Alnahhal (internal examiner) from Civil Engineering Department and Dr. Faris Matakah (external examiner) from Civil Engineering Department at Yarmouk University, Jordan and Dr. Mohamad Hassan (college representative) from CAM.

After deliberation, the head of the committee, Dr. Mohammad R. Irshidat, announced that the student passed the requirements for the master’s degree provided that he takes into consideration the comments brought up by the members of the thesis committee.

The Director of CAM, Dr. Nasser Al-Nuaimi said that the center, implementing the directives of the University administration to keep moving forward with the research process in these difficult and exceptional circumstances, is providing all the necessary means and procedures required for the continuation of research and academic activities taken into consideration the precautionary measures followed by Ministry of Public Health to prevent the spread of the novel coronavirus.



Qatar University Emergency Response Grant (ERG)

In response to the current conditions brought about by the emerging Coronavirus (COVID-19), the Research Support Office of the Vice President's Office for Research and Graduate Studies launches the Qatar University's ERG.

The Qatar University's Emergency Response Grant (ERG) is a new grant dedicated to emergency conditions. It supports new and early investigations that form the basis for further advanced research. This grant follows a short timeline to accelerate the launch of funded projects due to the critical nature of the conditions.

In view of the possible exceptional consequences of the current emergency conditions, and based on Qatar University's keenness about the health and safety of society, the University is committed to working with faculty and researchers to contribute to research related to these conditions. Qatar University's ERG for the emerging Coronavirus (COVID-19) is part of an international research effort to deal with the virus, and support the speed of rapid scientific research initiatives.

The ERG announced on April 5, 2020, aims to create research teams dedicated to

this type of virus, studying it from different perspectives, such as the incubation period, stages, shapes, and strains, and contribute to promoting awareness and appropriate protection plans, in addition to shedding light on the role of Qatar University in addressing emerging global concerns.

The grant supports several research tracks, which are basic molecular research, clinical research, social behavioral research, epidemiology, infectious diseases, public health, and e-health. The funded proposals related to each track are expected to be announced at the end of this month. The grant period will be one year with a budget of 150,000 Qatari riyals for each track (one or more projects will be funded from each track). A semi-annual report on the progress of the funded project must be submitted to the Research Support Office for evaluation.

It is worth mentioning that the research team for each proposal will consist of faculty members, researchers, and graduate students from colleges and research centers at Qatar University. Researchers from the State of Qatar who are not affiliated with the University can participate in the research proposals if necessary.

