

CONSTRUCTION AND EVALUATION OF INFECTIOUS cDNA
CLONES AND ANALYSIS OF PACKAGING DETERMINANTS OF
SOYBEAN DWARF VIRUS

BY

THANUJA THEKKE VEETIL

DISSERTATION

Submitted in partial fulfillment of the requirements
for the degree of Doctor of Philosophy in Natural Resources and Environmental Sciences
in the Graduate College of the
University of Illinois at Urbana-Champaign, 2010

Urbana, Illinois

Doctoral Committee:

Professor Glen L. Hartman, Chair
Associate Professor Leslie L. Domier, Director of Research
Professor Schuyler S. Korban
Associate Professor Kris N. Lambert

CONSTRUCTION AND EVALUATION OF INFECTIOUS cDNA CLONES AND ANALYSIS OF PACKAGING DETERMINANTS OF *SOYBEAN DWARF VIRUS*

ABSTRACT

Soybean dwarf virus (SbDV) is a phloem-limited, aphid-transmitted luteovirus that causes dwarfing of soybean plants. In the present study, infectious clones of two dwarfing isolates of SbDV were constructed, and methods for *Agrobacterium*-mediated inoculation of plants were standardized and used to introduce them into fava bean, *Nicotiana benthamiana*, 'Puget' pea and red clover plants. SbDV virions purified from *N. benthamiana* leaves infiltrated with either of these cDNA clones encapsidated genomic RNA (gRNA), but small subgenomic RNA (SsgRNA) was encapsidated by only one isolate and hence its packaging was isolate specific. Site-specific, deletion and domain-exchange mutagenesis indicated that, open reading frames (ORFs) 1, 2, 4, and 5 and interacting stem-loop structures in the 5' and 3' untranslated regions (UTRs) were required for replication of SbDV gRNA and that sequences in the 3' UTR were involved in isolate-specific encapsidation of SbDV SsgRNA. Preferential *trans*-encapsidation of non-replicating mutant gRNAs and large subgenomic RNA (LsgRNA) by coat protein provided by replicating wild-type virus suggested that encapsidation of SbDV gRNA is replication independent, and that two interacting signals located in ORFs 1 and 5 differentially regulate encapsidation of SbDV gRNA and LsgRNA. The present study also showed that soybean aphids (*Aphis glycines*) can vector SbDV, that the readthrough protein (RTP), a minor structural protein involved in specificity of aphid transmission, is much more diverse than the major coat protein among Midwestern SbDV isolates, and that no mutations occurred in the RTP as a result of aphid transmission of SbDV from red clover into soybean plants.

Dedicated to
My
Family

ACKNOWLEDGEMENTS

I am most heartily grateful to my research supervisor, Dr. Leslie L. Domier for his invaluable guidance, constant encouragement, and assistance offered to me throughout my research. He was always accessible and willing to offer help or advice whenever I needed. He is an enthusiastic scientist and a great mentor, and also had remarkable patience to my research inquiries. I believe my discussions with him on research topics instilled in me scientific curiosity which furthered my attempt to be a better researcher.

I am thankful to Dr. Glen L. Hartman, academic advisor, for his willingness to take me as a student, and advices and suggestions given to me throughout my program. I gratefully acknowledge my dissertation committee members, Drs. Cleora J. D'Arcy, Donald P. Briskin, Kris N. Lambert, and Schuyler S. Korban, for their suggestions to improve the quality of my research inquiry and dissertation. Ms. Nancy K. McCoppin provided effectual and timely assistance throughout my research which especially helped me accomplish much in shorter time, and I am thankful to her. It is my pleasure to thank Ms. Melissa Spoula for assisting me in my project work.

I would like to thank the United State Department of Agriculture, Agricultural Research Service, and North Central Soybean Research Program for funding my research projects. The partial financial assistance provided by Dr. Pradeep Khanna during the first year of my study provided me an opportunity to pursue graduate studies, and I gratefully acknowledge him. I also offer my thankfulness to all of those who supported me in many respects during the completion of the doctoral study and the research project.

I am forever beholden to my parents whose affection and sacrifices were always a source of inspiration to achieve my goals in life. Lastly but most importantly I acknowledge the loving support given by my husband, Jeb, my best counselor, without whose encouragement and help this degree would not have been possible. This chapter of my life in the University of Illinois was a wonderful opportunity to know many good people, meet great scientists, and visit several beautiful places across the United States.

TABLE OF CONTENTS

List of Tables		vi
List of Figures		vii
Chapter 1	<i>Soybean dwarf virus</i>	1
	References.....	6
Chapter 2	Sequence diversity of readthrough proteins and aphid transmission of <i>Soybean dwarf virus</i> isolates from the Midwestern United States	14
	Abstract.....	14
	Introduction.....	14
	Materials and methods.....	17
	Results.....	20
	Discussion.....	22
	References.....	24
Chapter 3	Construction and evaluation of infectivity and transmissibility of full-length cDNA clones of <i>Soybean dwarf virus</i>	32
	Abstract.....	32
	Introduction.....	32
	Materials and methods.....	34
	Results.....	41
	Discussion.....	43
	References.....	45
Chapter 4	Strain-specific packaging of <i>Soybean dwarf virus</i> small subgenomic RNA.....	58
	Abstract.....	58
	Introduction.....	58
	Materials and methods.....	60
	Results.....	65
	Discussion.....	68
	References.....	72
Chapter 5	Role of replication, long-distance RNA-RNA interactions and coding sequences in encapsidation of <i>Soybean dwarf virus</i>	82
	Abstract.....	82
	Introduction.....	83
	Materials and methods.....	86
	Results.....	94
	Discussion.....	99
	References.....	104
Summary.....		119

LIST OF TABLES

No.	Title	Page No.
2.1.	Changes in amino acid residues in readthrough domains of Midwestern <i>Soybean dwarf virus</i> isolates.....	28
2.2.	Sequences of oligonucleotide primers used to determine nucleotide sequences of regions encoding <i>Soybean dwarf virus</i> readthrough proteins	29
2.3.	Transmission of <i>Soybean dwarf virus</i> isolate CIAg1 by <i>Aphis glycines</i>	29
3.1.	Inoculation of plants with full-length <i>Soybean dwarf virus</i> (SbDV) cDNA clones by leaf infiltration of <i>Agrobacterium tumefaciens</i>	49
3.2.	Petiole, stem, and vein injection of <i>Agrobacterium tumefaciens</i> transformed with <i>Soybean dwarf virus</i> (SbDV) cDNA clones	49
3.3.	Nodal injection of <i>Agrobacterium rhizogenes</i> transformed with <i>Soybean dwarf virus</i> (SbDV) cDNA clones	50
3.4.	Vacuum infiltration of <i>Agrobacterium tumefaciens</i> transformed with <i>Soybean dwarf virus</i> (SbDV) cDNA clones	50
3.5.	Effects on <i>Soybean dwarf virus</i> (SbDV) infection of soil drenching of <i>Agrobacterium tumefaciens</i> and <i>Agrobacterium rhizogenes</i> harboring SbDV cDNA clones.....	51
3.6.	Effects on <i>Soybean dwarf virus</i> (SbDV) infection of overnight soaking of sprouted seeds with <i>Agrobacterium tumefaciens</i> and <i>Agrobacterium rhizogenes</i> harboring SbDV cDNA clones.....	51
3.7.	Aphid transmission of <i>Soybean dwarf virus</i> (SbDV) by membrane feeding of virus purified from tissues agroinfiltrated with SbDV cDNA clones	52
3.8.	Aphid transmission of <i>Soybean dwarf virus</i> (SbDV) from plants systemically infected by agroinjection with a cDNA clone of the CIIL2 isolate.....	52
3.9.	Differences in amino sequences of readthrough proteins of red clover (CIIL2) and soybean (W4) isolates of <i>Soybean dwarf virus</i>	53
4.1.	Differences in readthrough domain amino acid sequences in <i>Soybean dwarf virus</i> isolate W4 compared to CIIL2 and CIAg2 isolates	75
4.2.	Differences in nucleotide sequences of 3' untranslated regions (UTRs) in <i>Soybean dwarf virus</i> isolate W4 compared to CIIL2 and CIAg2 isolates	75
5.1.	Primer sequences and polymerase chain reaction (PCR) conditions used for the construction of open reading frame deletion (Δ ORF) mutants of <i>Soybean dwarf virus</i>	108
5.2.	Primer sequences and polymerase chain reaction (PCR) conditions used to detect encapsidation of <i>Soybean dwarf virus</i> (SbDV) RNAs extracted from virions purified from <i>Nicotiana benthamiana</i> tissues co-infiltrated with wild-type virus and mutants of SbDV	109
5.3.	Detection of <i>Soybean dwarf virus</i> (SbDV) infections by DAS-ELISA in <i>Nicotiana benthamiana</i> leaves agroinfiltrated with SbDV mutants.....	110

LIST OF FIGURES

No.	Title	Page No.
1.1.	Symptoms induced by <i>Soybean dwarf virus</i> (SbDV) in soybean	11
1.2.	Transmission of <i>Soybean dwarf virus</i> (SbDV)	12
1.3.	Organization and expression of <i>Soybean dwarf virus</i> (SbDV) genomic RNA.....	13
2.1	Genomic map and sequencing strategy for <i>Soybean dwarf virus</i> readthrough protein (RTP) encoding regions	30
2.2	Phylogenetic analysis of <i>Soybean dwarf virus</i> (SbDV) isolates collected from clover and soybean from Illinois and Wisconsin from 2003 through 2007.....	31
3.1	The cDNA cloning site derived from the plasmid pHST40	54
3.2	Synthesis and cloning of full-length copies of <i>Soybean dwarf virus</i> (SbDV) genomic RNAs	55
3.3	Confirmation of the presence of intact full-length clones of <i>Soybean dwarf virus</i> (SbDV) in <i>Escherichia coli</i> and <i>Agrobacterium tumefaciens</i>	56
3.4	Reverse transcription polymerase chain reaction (RT-PCR) products from systemic leaves of <i>Nicotiana benthamiana</i> plants agroinjected with full-length clones of <i>Soybean dwarf virus</i> isolate CIIL2	57
4.1	Northern blot and DAS-ELISA on sucrose-gradient fractions of purified <i>Soybean dwarf virus</i> virions from <i>Nicotiana benthamiana</i> tissues agroinfiltrated with isolate CIIL2.....	76
4.2	Encapsidated RNA content in virions of <i>Soybean dwarf virus</i> (SbDV) isolates CIAgt2 and W4.....	77
4.3	RNase sensitivity assay on <i>Soybean dwarf virus</i> (SbDV) virions and virion derived RNAs.....	78
4.4	RNA crosslinking analyses on <i>Soybean dwarf virus</i> virions	79
4.5	Nucleotide sequences of products of RNA ligase-mediated rapid amplification of cDNA ends (RLM-RACE) of encapsidated small RNAs from <i>Soybean dwarf virus</i>	80
4.6	Predicted structure of small subgenomic RNA (SsgRNA) of CIIL2 isolate of <i>Soybean dwarf virus</i>	81
5.1	Long-distance interactions in the expression of <i>Barley yellow dwarf virus</i> (BYDV) translation and replication	111
5.2	Diagrammatic representation of construction of open reading frame deletion (Δ ORF) mutants in full-length clones of <i>Soybean dwarf virus</i> isolate W4	112
5.3	The stem-loop structures in the 5'-and 3'-untranslated regions (UTRs) of <i>Soybean dwarf virus</i> predicted to be involved in long-distance interaction.....	113
5.4	Effect of open reading frame (ORF) deletions on replication of <i>Soybean dwarf virus</i> (SbDV).....	114
5.5	Northern blots on total RNAs extracted from <i>Nicotiana benthamiana</i> agroinfiltrated with untranslated region (UTR) mutants of <i>Soybean dwarf virus</i> (SbDV).....	115

5.6	Effects of open reading frame deletion (Δ ORF) mutations on the trans-encapsidation of mutant <i>Soybean dwarf virus</i> (SbDV) RNAs.....	116
5.7	Effect of replacement of readthrough domain and 3' untranslated region (UTR) sequences of <i>Soybean dwarf virus</i> (SbDV) isolate W4 with that of CIIL2 isolate on encapsidation of small subgenomic RNA (SsgRNA).....	117
5.8	Effects of mutations in the functional domain of replicase enzyme on replication and encapsidation of <i>Soybean dwarf virus</i> (SbDV) RNAs.....	118

CHAPTER 1

SOYBEAN DWARF VIRUS

Soybean dwarf was first identified as a disease of soybean causing severe yield losses in Japan in 1952 (Tamada, 1975). When incidence is high, *Soybean dwarf virus* (SbDV), the virus causing the disease is virulent enough to cause 50% crop loss in endemic areas of Japan (Tamada and Kojima, 1977). After its first report in Japan, different strains of SbDV were detected in many other countries including Australia, Ethiopia, Germany, Iran, Iraq, New Zealand, Nigeria, Syria, Tasmania, Tunisia and US (Kellock, 1971; Wilson and Close, 1973; Ashby and Kyriakou, 1982; Rossel and Thottapilly, 1982; Johnstone *et al.*, 1984; Makkouk *et al.*, 1997; Nair *et al.*, 2003; Abraham *et al.*, 2007; Makkouk and Kumari, 2009).

Host range and symptoms

Soybean dwarf virus belongs to the genus *Luteovirus* in the family *Luteoviridae* that includes two other genera *Polerovirus* and *Enamovirus*. The virus has a wide host range that includes mainly legumes. The major overwintering hosts of this luteovirus include white and red clover. Based on host ranges and symptoms, two strains, yellowing and dwarfing, were identified in soybean plants in Japan. The yellowing strains (YS and YP) are reported to primarily infect white clover (*Trifolium repens* L.), while dwarfing strains (DS and DP) primarily infect red clover (*T. pratense* L.) (Tamada, 1970; Damsteegt *et al.*, 1990). The dwarfing strains of SbDV cause pronounced stunting in soybean with shortened internodes and brittle curled leaves (Tamada, 1975) (Figure 1.1). On the other hand, yellowing strains cause severe interveinal chlorosis, rugosity and thickening of leaves. Both strains reduce the development of pods and ultimately result in economic loss depending upon the severity and time of infection.

SbDV in the United States

Soybean dwarf is not a serious disease of soybean in the US. Similar to Japan, clovers are considered the main weed legume harboring SbDV, which are widespread in the US., however,

infections of soybean by SbDV are rare. Soybean dwarf was first reported in Virginia in 2000 (Fayad *et al.*, 2000), and subsequently in Wisconsin in 2004 (Phibbs *et al.*, 2004) and in Illinois in 2006 (Thekkeveetil *et al.*, 2007). In the Midwest, about 50% of red clover plants are infected with SbDV, while less than 0.1% of soybean plants are SbDV-infected.

Transmission of SbDV

SbDV is transmitted persistently by aphids in a circulative and nonpropagative manner and efficiently transmitted only by colonizing aphids. Aphids feeding long enough to penetrate the phloem tissue can acquire and transmit the virus throughout their life times. In the aphid, SbDV particles pass into the alimentary canal from the stylet and then to the haemocoel from the hindgut (Figure 1.2). Subsequently, virus particles bind to and are transported across cells of accessory salivary gland and pass into the salivary duct to be expelled into the phloem tissue of a new plant during feeding (Gildow, 1999). The two barriers for SbDV in aphid vectors are hind gut and accessory salivary gland and the mechanisms for specificity of SbDV transmission were identified as receptor mediated endo- and exocytosis of the virions at these two barriers (Gildow *et al.*, 2000). Luteovirids do not infect or replicate in their aphid vectors (Gray and Gildow, 2003).

The SbDV-D and -Y strains reported from Japan are specifically transmitted by foxglove aphid, *Aulacorthum solani* (Kaltenbach) (DS and YS) and *Acyrtosiphon pisum* (Harris) (DP and YP) (Terauchi *et al.*, 2001). Endemic strains of SbDV isolated from legumes in the US are transmitted by *Aphis craccivora*, *A. pisum* and the green peach aphid, *Myzus persicae* (Damsteegt *et al.*, 1999). Japanese biotypes of *A. solani* are efficient vectors that readily colonize soybean, while the US biotypes do not colonize though they were shown to transmit SbDV-D and -Y isolates less efficiently than Japanese biotypes (Damsteegt and Hewings, 1986).

Isolates of SbDV from New Zealand and Australia were transmitted either by *A. solani* or *A. pisum*, but not by both (Damsteegt *et al.*, 1999). The clover aphid, *Nearctaphis bakeri* (Cowen), also efficiently transmits both Japanese and North American dwarfing isolates of SbDV (Honda, *et al.*, 1999; Harrison *et al.*, 2005). *Aphis glycines* Matsumura is the only aphid species that

colonizes soybean in North America. It has been reported to transmit *Indonesian soybean dwarf virus*, which causes symptoms similar to SbDV in soybean and is thought to be a member of the *Luteoviridae*, but is serologically distinct from SbDV (Iwaki *et al.*, 1980). Two studies have reported rare transmission of Japanese (Honda, 2001) and US isolates of SbDV (Damsteegt *et al.*, 2005) by *A. glycines*, while others have found no transmission of SbDV by *A. glycines* (Tamada *et al.*, 1969; Tamada, 1975; Harrison *et al.*, 2005; Wang *et al.*, 2006).

The presence of the soybean aphid (*A. glycines*), which also colonizes red clover, was first reported in the US in 2000 (Hartman *et al.*, 2001). Appearance of soybean dwarf in the Midwest along with the infestation of soybean fields with *A. glycines*, a potential vector of SbDV, and widespread distribution of SbDV-infected red clover necessitates an understanding of the sequence diversity of SbDV isolates in the region and transmission efficacy of *A. glycines* as a vector of SbDV. Currently there are no reports available on the sequence diversity of North American SbDV isolates from red clover, its overwintering host, and soybean plants or mutations that might occur in the SbDV genome when it infects soybean plants. The proposed study addressed these aspects on dwarfing strains of Midwestern isolates of SbDV.

Genome structure

The SbDV genome is organized into five open reading frames (ORFs) and three untranslated regions (UTRs), but lacks a polyadenylate sequence at the 3' end, and a 7-methyl GTP cap or genome-linked protein at the 5' end (Rathjen *et al.*, 1994; Terauchi *et al.*, 2001) (Figure 1.3). ORFs1 and 2 encode replication-related proteins and ORF4 putatively encodes the viral movement protein. ORFs3 and 5 are separated by an in-frame termination codon and encode 22 kiloDalton (kDa) coat protein (CP), the major capsid protein, and 65-88 kDa readthrough protein (RTP), the minor capsid protein. The ORF5 is expressed as a result of translational suppression of the CP UAG termination codon at the end of ORF3 to give a protein product of ORF5 fused to the C-terminal end of CP (Veidt *et al.*, 1988; Tacke *et al.*, 1990; Dinesh-Kumar *et al.*, 1992). The carboxy terminal extension of this RTP is referred to as the readthrough domain (RTD), which has a substantially conserved N-terminal half and a less conserved C-terminal half (Mayo and

Ziegler-Graff, 1996). The RTP is believed to be anchored in capsids via CP with the RTD protruding from the virion surface (Cheng *et al.*, 1994; Brault *et al.*, 1995).

Expression of viral genome

After the initial deposition into phloem cells by aphid vectors, luteovirus particles undergo disassembly (uncoating of protective CP) and release ssRNA into the cytoplasm. These RNAs are translated and express early gene products such as viral replicase. Viral replicase initiates replication from the 3' end of the genome, producing complimentary or minus strands from which positive-strand genomic and subgenomic (sg) RNAs are produced. SgRNAs are 5' truncated RNAs with the same 3' termini as that of the genomic RNAs. SgRNAs express the late genes such as CP, RTP and putative movement protein (D'Arcy and Domier, 2000). The viral RNAs and CPs are then assembled into infectious virions (packaging or encapsidation) and transported through plasmodesmata of the phloem cells to cause systemic infections.

Development of infectious cDNA clones is an important reverse genetic tool to study the functions of viral genes and understand the biology of the virus. Various methods have been developed in luteovirids to transmit viruses into plants without aphid vectors. The current study aimed to develop infectious clones of SbDV and an agroinfection or biolistic method to introduce them into plants.

Genome packaging or encapsidation is a highly specific process in which viral RNAs are distinguished from other cellular RNAs for assembly into virus particles. The major factors influencing packaging are packaging signals, structure of RNA and physical size of the virion (Rao, 2006). Very few studies have been conducted on the encapsidation of positive-strand RNA viruses and packaging signals have been reported in different parts of the viral genome. In potexviruses, the packaging signal is located at the 5' UTR (Sit *et al.*, 1994; Lee *et al.*, 1998), while in *Brome mosaic virus*, a tRNA-like structure located in the 3' UTR was involved in packaging (Choi *et al.*, 2002). In *Turnip crinkle virus* (Qu and Morris, 1997) and bromoviruses (Vriend *et al.*, 1986; Sacher and Ahlquist, 1989; Fox, 1994; Zhao *et al.*, 1995), the encapsidation signal was identified at the 3' and 5' ends of CP coding region respectively.

Replication of viral RNAs and their encapsidation are important processes in RNA viruses and both require specific interaction of *cis*-acting sequences and viral encoded proteins. Replication of single-stranded, positive-sense RNA viruses involves specific interactions between viral replication complexes and their cognate RNA templates, while encapsidation requires recognition of viral RNAs by the structural proteins. Protein-protein interaction and sequence-dependent and sequence-independent protein-RNA and RNA-RNA interactions play crucial roles in precise assembly and packaging of viral genomes (Rao, 2006).

In luteovirus, other than ORFs that encode replication related proteins, all other coding regions are dispensable for viral replication, although deletion of the CP-encoding region reduced the efficiency of viral replication (Sacher and Ahlquist, 1989; Reutenauer *et al.*, 1993; Mohan *et al.*, 1995). In other viruses like *Beet necrotic yellow vein virus* (BNYVV), RTP is necessary for efficient virus assembly (Schmitt, *et al.*, 1992), while in luteoviruses like *Barley yellow dwarf virus* (BYDV) (Filichkin *et al.*, 1994) and *Beet western yellows virus* (BWYV) (Reutenauer *et al.*, 1993), mutants lacking RTP or ORF5 sequences were shown to form virus particles. Also, stem-loop structures near the 3' end of the viral genome can interact with stem-loop structures in the 5' UTR and this RNA-RNA interaction is essential in translation, replication (Miller and White, 2006) and packaging (Rao, 2006) of plant viruses.

Few studies have investigated the roles of viral genes and UTRs in the replication and packaging of luteovirids and there have been none reported for SbDV. In BYDV-PAV, another closely related luteovirus, only genomic RNAs are packaged into virions, (Mohan *et al.*, 1995) which suggested that the region upstream of the initiation of transcription for sgRNAs have a crucial role in packaging. In the present study, encapsidated RNA content of SbDV virions and the involvement of coding regions and UTRs in the replication and packaging of the virus are investigated with the reverse genetic system developed through the agroinfection of the infectious clones of SbDV. Information on the viral components involved in these crucial steps in the viral life cycle will help the thorough understanding of the biology of the virus.

OBJECTIVES

1. Analyze the amino acid sequence diversity of RTP of SbDV isolates from red clover and soybean and study the adaptational mutations in the RTP of SbDV in response to its movement from red clover to soybean.
2. Study the transmission potential of *A. glycines* as a vector of SbDV.
3. Construct infectious full-length cDNA clones of SbDV and develop an agroinfection or biolistic method to introduce SbDV clones into plants.
4. Study the encapsidated RNA content of SbDV virions.
5. Analyze the involvement of coding regions and interacting stem-loops in the 5' and 3' UTRs in replication and packaging of SbDV.

REFERENCES

- Abraham, A.D., Menzel, W. and Vetten, H.J. 2007. First report of *Soybean dwarf virus* (Genus *Luteovirus*) infecting faba bean and clover in Germany. *Plant Dis.* 91:1059.
- Ashby, J.W. and Kyriakou, A. 1982. Purification and properties of subterranean clover red leaf virus. *N. Z. J. Agric. Res.* 25:607-612.
- Brault, V., Van den Heuvel, J. F., Verbeek, M., Ziegler-Graff, V., Reutenauer, A., Herrbach, E., Garaud, J. C., Guilley, H., Richards, K. and Jonard, G. 1995. Aphid transmission of beet western yellows luteovirus requires the minor capsid read-through protein P74. *EMBO J.* 14:650-659.
- Cheng, S.L., Domier, L.L. and D'Arcy, C.J. 1994. Detection of the readthrough protein of barley yellow dwarf virus. *Virology* 230:323-334.
- Choi, Y.G., Dreher, T.W. and Rao, A.L.N. 2002. tRNA elements mediate the assembly of an icosahedral RNA virus. *Proc. Natl. Acad. Sci. USA* 99:655-660.
- Damsteegt, V. D., Stone, A. L., Russo, A. J., Luster, D. G., Gildow, F. E. and Smith, O. P. 1999. Identification, characterization, and relatedness of luteovirus isolates from forage legumes. *Phytopathology* 89:374-379.
- Damsteegt, V. D., Stone, A., Schneider, W., Sherman, D., Gildow, F. and Luster, D. 2005. The soybean aphid, *Aphis glycines*, a new vector of endemic dwarfing and yellowing isolates of soybean dwarf luteovirus. *Phytopathology* 95:S22.

- Damsteegt, V.D. and Hewings, A.D. 1986. Comparative transmission of soybean dwarf virus by three geographically diverse populations of *Aulacorthum* (= *Acyrtosiphon*) *solani*. *Ann. Appl. Biol.* 109:453-463.
- Damsteegt, V.D., Hewings, A.D. and Sinsermann, A.B. 1990. Soybean dwarf virus: experimental host range, soybean germplasm reactions and assessment of potential threat to US soybean production. *Plant Dis.* 74:992-995.
- D'Arcy, C.J. and L.L. Domier. 2000. Barley yellow dwarf. *The Plant Health Instructor*. DOI: 10.1094/PHI-I-2000-1103-01.
- Dinesh Kumar, S.P., Brault, V. and Miller, W.A. 1992. Precise mapping and *in vitro* translation of a trifunctional subgenomic RNA of barley yellow dwarf virus. *Virology* 187:711-722.
- Fayad, A., Tolin, S.A. and Baldwin, M. 2000. Natural infection of soybean with a soybean dwarf-like virus in Virginia. *Phytopathology* 90:S132.
- Filichkin, S.A., Lister, R.M., McGrath, P.F. and Young, M.J. 1994. *In vivo* expression and mutational analysis of the barley yellow dwarf virus readthrough gene. *Virology* 205:290-299.
- Fox, J.M. 1994. RNA-protein interactions in icosahedral virus assembly. *Semin. Virol.* 5:51-60.
- Gildow, F. E. 1999. Luteovirus transmission and mechanisms regulating vector specificity. *The Luteoviridae* (Eds. Smith, H.G. and barker, H), CAB international, Wallingford, p. 88-112.
- Gildow, F. E., Damsteegt, V. D., Stone, A. L., Smith, O. P. and Gray, S. M. 2000. Virus-vector cell interactions regulating transmission specificity of soybean dwarf luteoviruses. *J. Phytopathol.* 148:333-342.
- Gray, S. and Gildow, F. E. 2003. Luteovirus-aphid interactions. *Annu. Rev. Phytopathol.* 41:539-566.
- Harrison, B., Steinlage, T.A., Domier, L.L. and D'Arcy, C.J. 2005. Incidence of *Soybean dwarf virus* and identification of potential vectors in Illinois. *Plant Dis.* 89:28-32.
- Hartman, G.L., Domier, L.L., Wax, L.M., Helm, C.G., Onstad, D.W., Shaw, J.T., Solter, L.F., Voegtlin, D.J., D'Arcy, C.J., Gray, M.E., Steffy, K.L., Isard, S.A. and Orwick, P.L. 2001. Occurrence and distribution of *Aphis glycines* on soybeans in Illinois in 2000 and its potential control. *Plant Health Prog.* doi: 10. 1094/PHP-2001-0205-01-HN
- Honda, K. 2001. Aphids and their transmission of viruses on soybeans in Japan. *Agrochemicals Japan* 79:2-7.

- Honda, K., Kanematsu, S. and Mikoshiya, Y. 1999. Dwarfing strain of soybean dwarf luteovirus transmitted by *Nearctaphis bakeri* and *Acyrtosiphon pisum*. *Ann. Phytopathol. Soc. Jap.* 65:387.
- Iwaki, M., Roechan, M., Hibino, H., Tochihara, H. and Tantera, D. M. 1980. A persistent aphid borne virus of soybean, Indonesian soybean dwarf virus, transmitted by *Aphis glycines*. *Plant Dis.* 64:1027-1030.
- Johnstone, G.R., Liu, H. and Duffus, J.E. 1984. First report of subterranean clover red leaf virus in the western hemisphere. *Phytopathology* 74:795.
- Kellock, A.W. 1971. Red leaf virus- A newly recognized virus disease of subterranean clover. (*T. subterraneum* L.). *Aust. J. Agric. Res.* 22:615-624.
- Lee, Y.S., Lin, B. Y., Hsu, Y.H., Chang, B.Y. and Lin, N.S. 1998. Subgenomic RNAs of bamboo mosaic potexvirus-V isolate are packaged into virions. *J. Gen. Virol.* 79:182-1832.
- Makkouk, K.M., Damsteegt, V.D., Johnstone, G.R., Katul, G.R., Lesemann, D.E. and Kumari, S.G. 1997. Identification and some properties of soybean dwarf luteovirus affecting lentil in Syria. *Phytopathol. Mediterr.* 36:135-144.
- Makkouk, K.M. and Kumari, S.G. 2009. Epidemiology and integrated management of persistently transmitted aphid-borne viruses of legume and cereal crops in West Asia and North Africa. *Virus Res.* 141:209-218.
- Mayo, M.A. and Ziegler-Graff, V. 1996. Molecular biology of luteoviruses. *Adv. Virus Res.* 46:413-460.
- Miller, W.A. and White, K.A. 2006. Long distance RNA-RNA interactions in plant virus gene expression and replication. *Annu. Rev. Phytopathol.* 44:19.1-19.21.
- Mohan, B.R., Dinesh-Kumar, S.P. and Miller, W.A. 1995. Genes and cis-acting sequences involved in replication of barley yellow dwarf virus-PAV RNA. *Virology* 212:186-195.
- Nair, A., Karray, R.H., Kumari, S.G. and Makkouk, K.M. 2003. A survey of viruses affecting faba bean (*Vicia faba*) in Tunisia includes first record of soybean dwarf virus. *Plant Dis.* 87:1151.
- Phibbs, A., Barta, A. and Domier L.L. 2004. First report of *Soybean dwarf virus* on soybean in Wisconsin. *Plant Dis.* 88:1285.
- Qu, F. and Morris, T.J. 1997. Encapsidation of turnip crinkle virus is defined by a specific packaging signal and RNA size. *J. Virol.* 71:1428-1435.

- Rathjen, J.P., Karageorgos, L.E., Habili, N., Waterhouse, P.M. and Symons, R.H. 1994. Soybean dwarf luteovirus contains the third variant genome type in the luteovirus group. *Virology* 198:671-679.
- Rao, A.L.N. 2006. Genome packaging by spherical plant RNA viruses. *Annu. Rev. Phytopathol.* 44:61-87.
- Reutenauer, A., Ziegler-Graff, V., Lot, H., Scheidecker, D., Guilley, H., Richards, K. and Jonard, G. 1993. Identification of beet western yellows luteovirus genes implicated in viral replication and particle morphogenesis. *Virology* 195:692-699.
- Rossel, H.W. and Thottappilly, G. 1982. Soybean dwarf, a potentially disastrous virus disease of soybean in Nigeria. *International Institute of Tropical Agricultural Research Briefs* 3:3-5.
- Sacher, R. and Ahlquist, P. 1989. Effects of deletions in the N-terminal basic arm of brome mosaic virus coat protein on RNA packaging and systemic infection. *J. Virol.* 63: 4545-4552.
- Schmitt, C., Balmori, E., Jonard, G., Richards, K.E. and Guilley, H. 1992. *In vitro* mutagenesis of biologically active transcripts of beet necrotic yellow vein virus RNA 2: Evidence that a domain of the 75-kDa readthrough protein is important for efficient virus assembly. *Proc. Natl. Acad. Sci.* 89:5715-5719.
- Sit, T. L., Leclerc, D. and Abouhaidar, M. G. 1994. The minimal 5' sequence for *in vitro* initiation of papaya mosaic potexvirus assembly. *Virology* 199:238-242.
- Tacke, E., Pruffer, D., Salamini, F. and Rohde, W. 1990. Characterization of a potato leaf roll luteovirus subgenomic RNA: Differential expression by internal translation initiation and UAG suppression. *J. Gen. Virol.* 71:2265-2272.
- Tamada, T. 1970. Aphid transmission and host range of soybean dwarf virus. *Ann. Phytopathol. Soc. Japan* 36:266-274.
- Tamada, T. 1975. Studies on the soybean dwarf disease. Bulletin No.25 Hokkaido Prefectural Agricultural Experiment Stations, Hokkaido, Japan.
- Tamada, T. and Kojima, M. 1977. Soybean dwarf virus. Common Wealth Mycological Institute and Association of Applied Biologists Descriptions of plant viruses no. 179, p.4
- Tamada, T., Goto, K., Chiba, I. and Suwa, T. 1969. Soybean dwarf, a new virus disease. *Ann. Phytopathol. Soc. Japan* 35:282-285.
- Terauchi, H., Kanematsu, S., Honda, K., Mikoshiba, Y., Ishiguro, K. and Hidaka, S. 2001. Comparison of complete nucleotide sequences of genomic RNAs of four *Soybean dwarf virus* strains that differ in their vector specificity and symptom production. *Arch. Virol.* 146:1885-1898.

- Thekkeveetil, T., Hobbs, H.A., Wang, Y., Kridelbaugh, D., Donnelly, J., Hartman, G.L. and Domier, L.L. 2007. First report of *Soybean dwarf virus* in soybean in northern Illinois. *Plant Dis.* 91:1686.
- Veidt, I., Lot, H., Leiser, M., Scheidecker, D., Guilley, H., Richards, K. and Jonard, G. 1988. Nucleotide sequence of beet western yellows virus RNA. *Nucleic Acids Res.* 16:9917-9932.
- Vriend, G., Verduin, B.J. and Hemminga, M.A. 1986. Role of the N-terminal part of the coat protein in the assembly of cowpea chlorotic mottle virus. A 500 MHz proton nuclear magnetic resonance study and structural calculations. *J. Mol. Biol.* 191:453-460.
- Wang, R.Y., Kritzman, A., Hershman, D.E. and Ghabrial, S.A. 2006. *Aphis glycines* as a vector of persistently and nonpersistently transmitted viruses and potential risks for soybean and other crops. *Plant Dis.* 90:920-926.
- Wilson, J. and Close, R.C. 1973. Subterranean clover red leaf virus and other legume viruses in Canterbury. *N. Z. J. Agric. Res.* 16:305-310.
- Zhao, X., Fox, J.M., Olson, N.H., Baker, T.S. and Young, M.J. 1995. *In vitro* assembly of cowpea chlorotic mottle virus from coat protein expressed in *Escherichia coli* and *in vitro*-transcribed viral cDNA. *Virology* 207:486-494.

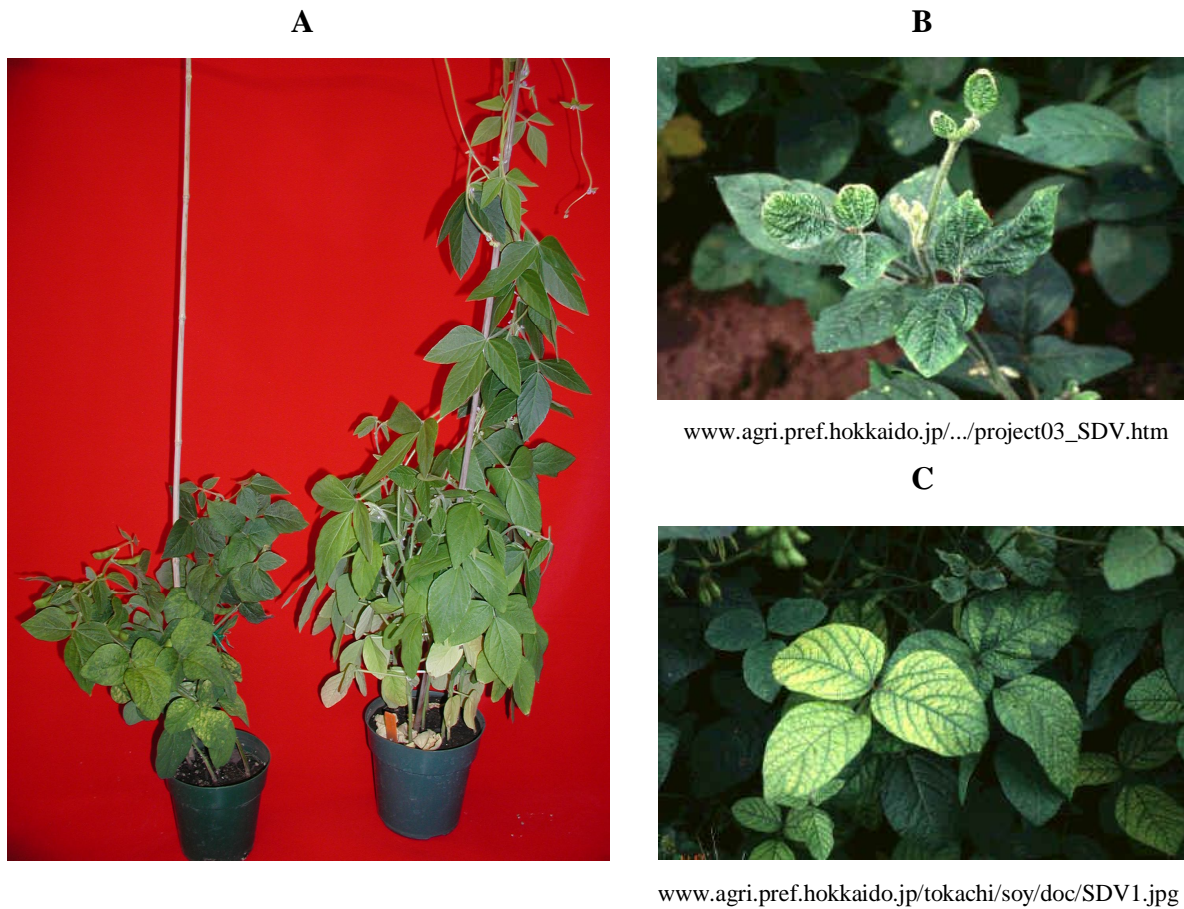
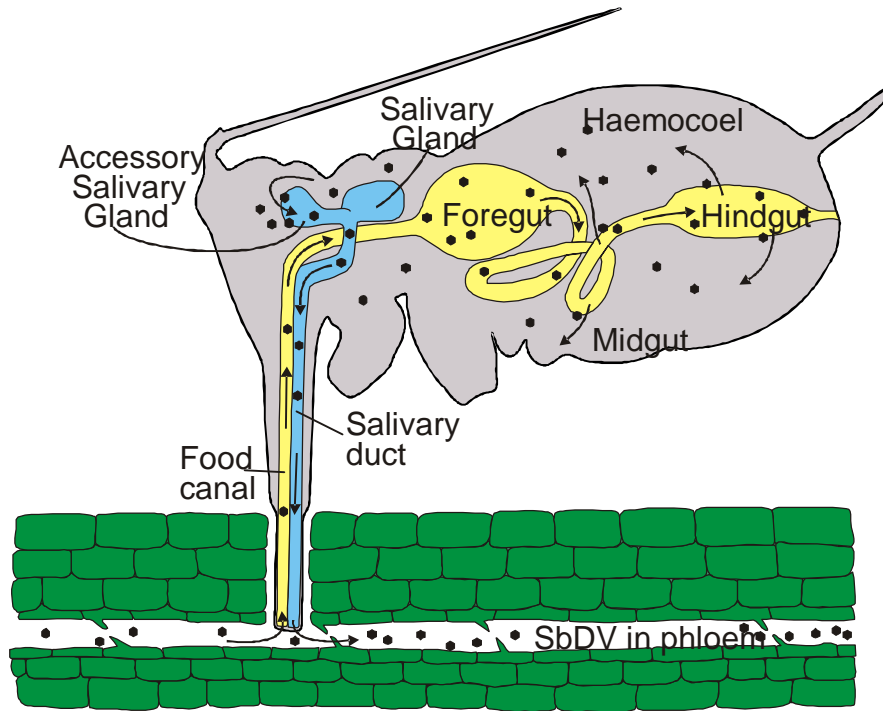

Figure 1.1. Symptoms induced by *Soybean dwarf virus* (SbDV) in soybean. **(A)** The dwarfing strains of SbDV (SbDV-D) cause pronounced stunting in soybean with shortened internodes. **(B)** SbDV-D infected leaves are dark green, brittle and curled. **(C)** Yellowing strains cause severe interveinal chlorosis, rugosity and thickening of leaves.



(Courtesy L.L. Domier)

Figure 1.2. Transmission of *Soybean dwarf virus* (SbDV). SbDV is transmitted persistently by colonizing aphids in a circulative and nonpropagative manner. Aphids feeding long enough to penetrate the phloem tissue can acquire and transmit the virus throughout their lifetimes. In the aphid, SbDV particles pass into the alimentary canal from the stylet and then to the haemocoel from the hindgut. Subsequently, virus particles bind to and are transported across cells of accessory salivary gland and pass into the salivary duct to be expelled into the phloem tissue of a new plant during feeding. Virus particles are transported across membranes in the hind gut and accessory salivary gland by receptor mediated endo- and exocytosis, which imparts strain specificity of SbDV transmission. SbDV does not replicate within its aphid vectors.

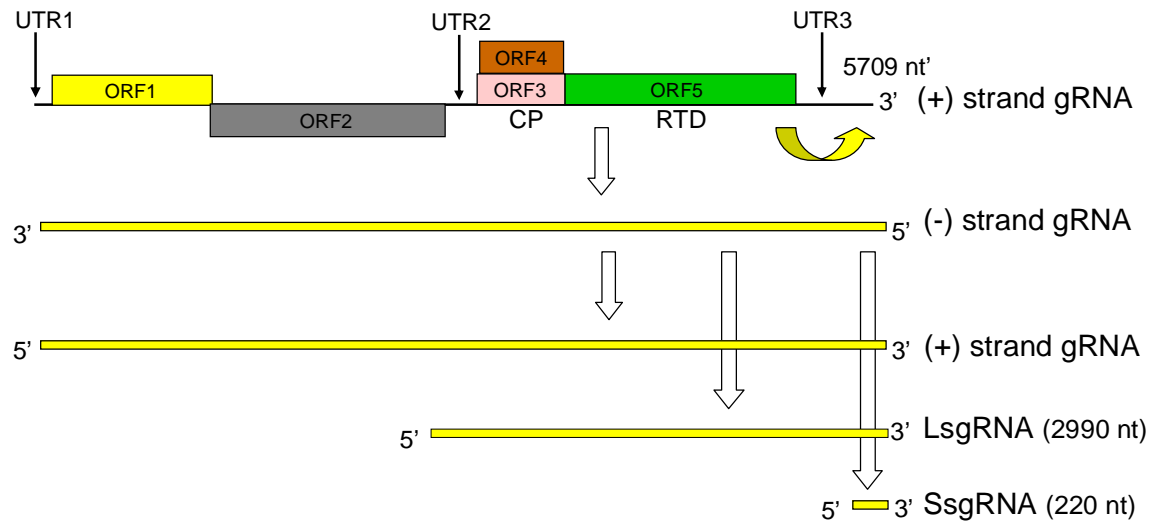

Figure 1.3. Organization and expression of *Soybean dwarf virus* (SbDV) genomic RNA. The SbDV genome is organized into five open reading frames (ORFs) and three untranslated regions (UTRs), but lacks a polyadenylate sequence at the 3' end, and a 7-methyl GTP cap or genome-linked protein at the 5' end. ORFs1 and 2 encode replication-related proteins and ORF4 putatively encodes the viral movement protein. ORFs3 and 5 are separated by an in-frame termination codon and encode the 22 kiloDalton (kDa) major coat protein (CP) and the 65-88 kDa readthrough protein (RTP), the minor capsid protein. The ORF5 is expressed as a result of translational suppression of the CP UAG termination codon at the end of ORF3 to give a protein product of ORF5 fused to the C-terminal end of CP. The carboxy terminal extension of this RTP is referred to as the readthrough domain (RTD). SbDV replicates from a minus-strand RNA transcribed by viral polymerases from the genomic RNA (gRNA). From this minus-strand RNA, plus-strand gRNA and two subgenomic RNAs are transcribed. The large subgenomic RNA (LsgRNA) expresses ORFs3, 4 and 5. The small subgenomic RNA (SsgRNA) does not contain an ORF and its function is unknown.

CHAPTER 2

SEQUENCE DIVERSITY OF READTHROUGH PROTEINS AND APHID TRANSMISSION OF *SOYBEAN DWARF VIRUS* ISOLATES FROM THE MIDWESTERN UNITED STATES

ABSTRACT

Soybean dwarf virus (SbDV), a member of the family *Luteoviridae*, is phloem-limited and persistently transmitted by colonizing aphids in a circulative and nonpropagative manner. The readthrough protein (RTP), a minor component of viral capsids, is composed of the coat protein (CP) with a C-terminal extension known as the readthrough domain (RTD). The RTD is reported to have a significant role in specificity of aphid transmission of luteovirids. In this study, the amino acid sequence diversity of RTPs of 24 dwarfing isolates of SbDV from Wisconsin and Illinois was analyzed. Among these isolates, the nucleotide sequence identity ranged from 95 to 100%. The predicted amino acid sequences differed at 56 amino acid positions in the 54 kDa RTD compared to only five positions in the 22 kDa CP. Phylogenetic analysis of both amino acid and nucleotide sequences revealed three distinct clusters of SbDV isolates. One of the Illinois clover isolates was transmitted with low efficiency by *Aphis glycines*.

INTRODUCTION

Soybean dwarf virus (SbDV) is a single-stranded positive-sense RNA virus first identified in cultivated soybean (*Glycine max* L. Merr.) in Japan. The 25-nm isometric virion of SbDV encapsidates genomic RNA of 5.7 kilobases (kb) in dwarfing isolates (Terauchi *et al.*, 2003; Domier *et al.*, 2005) and 5.8 kb in yellowing isolates (Rathjen *et al.*, 1994; Terauchi *et al.*, 2001). The virus is phloem limited and transmitted only by aphids in a circulative, nonpropagative and often strain-specific manner (Tamada, 1970; Johnstone *et al.*, 1984; Damsteegt *et al.*, 1999; Honda *et al.*, 1999; Gildow *et al.*, 2000; Terauchi *et al.*, 2001; Damsteegt *et al.*, 2005). Selective interaction of the viral capsid structures, coat protein (CP) and readthrough domain (RTD), with

the membranes of the accessory salivary gland of vector aphids is assumed to be responsible for the specificity of aphid transmission existing among luteoviruses (Gray and Gildow, 2003) and these interactions can result in differential transmission efficiency by aphids for different isolates. In luteovirids, the readthrough protein (RTP), a fusion product of open reading frame (ORF) 3 and ORF5, is described as a multifunctional protein having roles in aphid transmission, symptomatology, movement, gene silencing activities and accumulation of virus in aphids and plants (Brault *et al.*, 1995; Brault *et al.*, 2000; Brault *et al.*, 2002).

Several mutational studies identified a definite role of RTD in luteovirus transmission. The inability of vector aphids to transmit the mutated particles of another luteovirid, *Beet western yellows virus* (BWYV), lacking RTP suggested that RTP is required for an aphid to be able to transmit the virus and establish a systemic infection in a host plant (Cheng *et al.*, 1994; Brault *et al.*, 1995; Bruyere *et al.*, 1997). Though aphids failed to transmit the RTD mutated BWYV by feeding on infected plants, they successfully transmitted the virus when injected into the haemocoel, suggesting that some changes in RTD can affect acquisition of the virus into the aphid haemocoel across the gut membrane (Brault *et al.*, 2000).

There are contradictory reports on the role of N- and C- terminal halves of the RTP in aphid transmission and specificity in different luteoviruses. Comparison of amino acid sequences of RTD of six luteoviruses revealed a higher degree of similarity in the N-terminal region of the polypeptide suggesting the possibility of vector specificity in the C- terminal portion of the RTD (Guilley *et al.*, 1994; Jolly and Mayo, 1994). Conversely, vector specificity was attributed to the N- terminal portion of RTD (N-RTD) in BWYV (Brault *et al.*, 2000). Deletion mutations in the C-RTD of BWYV resulted in aphid transmissible virus particles with truncated RTP, while the N-RTD mutants were non-transmissible. Also, purified *Barley yellow dwarf virus*-PAV (BYDV-PAV) particles with C-terminally truncated RTP were aphid transmissible (Filichkin *et al.*, 1994) suggesting that C-RTD may not be essential for aphid transmission.

Immunological studies also have suggested an involvement of the N-RTD in the aphid transmission process. Antisera developed against CP or C-RTD of *Cereal yellow dwarf virus* (CYDV-RPV) did not affect aphid transmissibility when mixed with purified virus while,

antisera against the N-RTD inhibited aphid transmission (McGrath *et al.*, 1996). The N-RTD is also essential for virus binding to proteins produced by symbiotic bacteria in the haemolymph of aphids, which enhances virus persistence in aphids (Van den Heuvel *et al.*, 1997).

Mutations in the RTD of existing viral isolates could possibly lead to evolution of new aphid transmission phenotypes (Terauchi *et al.*, 2003). In the Midwest, about 50% of red clover (*Trifolium pratense*) plants are infected with SbDV, while less than 0.1% of soybean plants are SbDV-infected. The soybean-colonizing aphid, *Aphis glycines* can also colonize red clover, thus it can potentially transfer endemic isolates of SbDV from red clover to cultivated soybeans. The widespread distribution of SbDV-infected red clover and the extraordinary biotic potential of *A. glycines* (Ragsdale *et al.*, 2004), a potential SbDV vector, along with appearance of soybean dwarf in the Midwest necessitates an understanding of the sequence diversity of SbDV isolates in the region and transmission potential of *A. glycines*. In the present study, amino acid sequence differences in the RTP among red clover and soybean isolates of SbDV were analyzed. The ability of *A. glycines* to transmit red clover isolates of SbDV was analyzed with an Illinois SbDV isolate from red clover.

Viral RNA genomes are typically subjected to a relatively high rate of mutation during replication in host plants (Domingo and Holland, 1997). The N-terminal half of RTP in luteovirus is highly conserved compared to more diverse sequences of C-terminal half. Considering the role of N-RTD in differential transmission of luteovirus isolates, the amino acid differences in N-RTD among isolates could indicate the adaptations for transmission by different vector population. Therefore, experiments were conducted to detect possible mutations in the RTP of clover SbDV isolates that result from transmission by clover aphids or adaptation to soybean plants.

MATERIALS AND METHODS

I. Sequence diversity of RTP

Virus isolates

SbDV isolates collected from red clover and soybean plants in Wisconsin and Illinois during 2003 through 2007 were used for this study (Phibbs *et al.*, 2004; Thekkeveetil *et al.*, 2007). The RTP-encoding regions of 24 isolates, seven from Wisconsin and 17 from Illinois (Table 2.1) were selected for analysis.

Reverse transcription polymerase chain reaction (RT-PCR)

Total RNA was extracted from 100 mg of frozen leaf tissue using Trizol reagent according to the manufacturer's protocol (Invitrogen Corp., Carlsbad, CA). Approximately 1 µg of total RNA was reverse transcribed with Superscript II reverse transcriptase (Invitrogen) and a SbDV-specific reverse primer 5688R (5'-GAGAGACCCGGGGCAGGTGGA-3') complementary to nucleotides (nt) 5698-5709 of the SbDV genome. The reaction mixture was incubated at 42°C for 50 min and reverse transcription was terminated by heating the sample at 70°C for 15 min. The region containing ORFs3 and 5 was amplified with primers 2563F (5'-AGGACAAACTCGGGCTCAGGAAAG-3', nt 2563-2586) and 5688R (both at final concentrations of 0.2 µM) and Ex *Taq*, a DNA polymerase (Takara Mirus Bio, Madison, WI), according to the manufacturer's instructions. PCR was carried out for 40 cycles of 94°C for 30 s, 65°C for 30 s, and 72°C for 5 min in a PTC-200 thermocycler (MJ Research, Waltham, MA). RT-PCR products were analyzed on 1% agarose gels. When necessary, PCR products were recovered from 0.8% agarose gels (SeaKem GTG, FMC Bioproducts, Philadelphia, PA) using a QIAquick Gel Extraction Kit (Qiagen Inc. Valencia, CA). Purified PCR products were quantified by comparing band intensities to bands in marker DNA.

Sequencing analysis

Both strands of the purified RT-PCR products (approximately 60-80 ng) of each virus isolate were directly sequenced (Figure 2.1) with Big Dye fluorescent terminator sequencing reagents as

recommended by the manufacturer (Applied Biosystems, Foster City, CA) at the University of Illinois, W.M. Keck Center for Comparative and Functional Genomics using the primers indicated in Table 2.2. Nucleotide sequences were edited and assembled with Sequencher 4.7 (Gene Codes, Ann Arbor, MI). The predicted amino acid sequences of CP and RTD were derived using DNAMAN (Lynnon BioSoft, Quebec, Canada) and aligned using ClustalX (Higgins *et al.*, 1992). Alignments were edited with GeneDoc (Nicholas *et al.*, 1997), and neighbor-joining phylogenetic trees were constructed and displayed using MEGA 4.0 (Tamura *et al.*, 2007). The Japanese SbDV isolate SbDV-DP (AB038150) was incorporated into the analysis as an outgroup. The ratio (ω) of nonsynonymous (K_a) to synonymous (K_s) substitutions in the RTP sequences were calculated using Selecton 2007 (Stern *et al.*, 2007). Values of ω significantly greater than 1.0 at a particular site within a protein coding region indicate that the site is potentially under positive selection. Values of ω significantly less than 1.0 indicate that the site is potentially under purifying selection.

II. Transmission of SbDV by *A. glycines*

In preliminary trials, a dwarfing isolate of SbDV (ClAgt1), which was collected from Illinois during 2007, was used for the transmission study with *A. glycines*. The virus was transmitted from infected clover plants to unifoliolate soybean (cv. 'Shirotsurunoko') seedlings after 48 hr of acquisition access by *Nearctaphis bakeri*. Plants were screened for infection after 14 days by double-antibody sandwich enzyme-linked immunosorbent assay (DAS-ELISA). Leaves from infected plants were collected, and *A. glycines* were allowed to feed for 48 hr and then transferred to 1-week-old unifoliolate soybean seedlings (cv. 'Wayne'). Aphids were allowed to colonize plants, and plants were tested after 2 - 3 weeks by DAS-ELISA and RT-PCR.

To verify that soybean cv. Wayne plants were infected with the same SbDV isolate, ClAgt1, the RTP of virus in cvs. Wayne and Shirotsurunoko was amplified and partially sequenced. For reverse transcription reaction, total RNA was extracted from infected plants (one each from both Wayne and Shirotsurunoko), reverse transcribed to cDNA and amplified with primer pair 5688R and 3847F (5' -CGCAATGGTACTCACAGAATT-3') (PCR conditions: 35 cycles of 94°C for 30 s, 54°C for 30 s and 72°C for 3 min). The purified RT-PCR products were sequenced with

Big Dye fluorescent terminator sequencing reagents with primer 4786R (5'-CCYCGGGAGACAAAGTGT-3') and the nucleotide sequences obtained from Shiroturunoko and Wayne were compared.

In further transmission trials, nonviruliferous *A. glycines*, maintained on healthy soybean plants, were transferred and allowed to colonize SbDV-infected Itachi and Koganejuro soybean plants. To avoid damaging the stylets of viruliferous *A. glycines*, portions of colonized leaves containing approximately 10 aphids were excised and transferred to unifoliate leaves of the same soybean cultivars. After 2 weeks, the plants were evaluated for SbDV infection by DAS-ELISA.

DAS-ELISA

Leaf samples were ground using the double-roller plant sap extractor (Erich Pollahne, West Germany) in 1ml general extraction buffer (GEB) (20 mM sodium sulfite (1.3g/l), 2% PVP 24-40,000, 2% tween 20, 0.02 % sodium azide, 0.2% egg albumin, grade II in phosphate buffered saline + Tween 20 (PBST; 20 mM potassium phosphate, 150 mM NaCl, 0.05% (w/v) Tween-20, pH 7.2) and tested according to Agdia (Elkhart, IN) protocol. Absorbance measurements were made on a BioTek model 307 EIA Reader (Dynex Technologies Inc., VA) at 405 nm. SbDV infected and uninfected plants were included as positive and negative controls, respectively, in all ELISA plates and samples were duplicated. Test wells were rated positive if their mean absorbances exceeded twice the mean absorbance of negative control wells.

III. Analysis of adaptive mutations in *Soybean dwarf virus*

A second Illinois red clover isolate of SbDV (CIIL4) that was collected during 2005 was used to detect mutations that might result from adaptation to new host (soybean). Viruliferous clover aphids, maintained on the CIIL4-infected red clover plants, were transferred to healthy unifoliate soybean plants, and were killed after 72 hr of inoculation access. Plants were transferred to a greenhouse, and total RNAs were extracted from SbDV infected symptomatic plants one month after inoculation. RT-PCR of infected leaf samples, sequencing of RTP and subsequent analysis

of sequences were conducted as described above. The predicted amino acid sequences of CIIL4 isolate from red clover and soybean were compared to detect possible mutations in RTP.

RESULTS

Sequence diversity of RTP

Nucleotide sequence analysis of Midwestern SbDV isolates revealed that ORFs3 and 5 (nt 3019 through 5091) were 2073 nt in length including stop codons, and encoded a total of 689 amino acids. Nucleotide sequence identities among the Midwestern SbDV isolates ranged from 95-100%. Of the Japanese SbDV isolates, the RTP nucleotide sequences of Midwestern SbDV isolates were most similar to SbDV-DP (AB038150; 94-95% identical), followed by SbDV-DS (AB038149; 87-88% identical), SbDV-YP (AB038148; 67-70% identical), and SbDV-YS (AB038147; 67-68% identical). The core CP consisted of 603 nt, predicted to encode a protein of 200 amino acids. The RTD sequences consisted of 1470 nt encoding 489 amino acids.

When predicted amino acid sequences of 22-kDa CP sequences were compared, only five of the 200 amino acid positions (8, 18, 54, 182, and 194 in isolates ClAgt2, Wisc5, ClAgt1, Putnam, and JoeDavies3, respectively; data not shown) differed among the 24 Midwestern SbDV isolates. In contrast, 18 of the 189 amino acids of the predicted product of ORF4, which is contained within ORF3, varied among the isolates indicating that the CPs were more highly conserved than the putative movement proteins. Of the three polypeptides, RTD was highly variable and differed at 56 of 489 amino acid positions.

Predicted amino acid sequences of the N-RTD (positions 201-445) and C-RTD (positions 446-689) of the Midwestern SbDV isolates showed different patterns of sequence variability. The N-RTD includes the predicted proline hinge (Terauchi *et al.*, 2001), which was highly conserved in all isolates sequenced, and contained fewer (23) amino acid substitutions than the C-RTD. The C-RTD, was more variable and contained 33 (59%) of the 56 amino acid substitutions indicating that C-RTD is less well conserved than the N-RTD. Out of the 23 amino acid changes observed in the N-RTDs, three changes, T to N, A to V, and A to P at positions 333, 397, and 400,

respectively, were shared among nine soybean SbDV and two clover isolates. The predicted amino acid sequence of the RTP of the Japanese SbDV DP strain (AB038150), but not the DS, YP or YS strains, contained the same amino acids at these positions. Of these differences, the change of A to P would probably alter the structure of the RTD most significantly.

Phylogenetic analysis

The dendrograms derived from amino acid and nucleotide sequences were similar and grouped SbDV isolates into three distinct clusters primarily based on sequences encoding the N-RTD. Clustering based on the nucleotide sequences (Figure 2.2) was more precise than clustering based on amino acid sequences due to availability of larger numbers of informative characters (data not shown). The largest clade was divided into two subgroups (1 and 2). All 12 members of Subgroup 1 contained A to V and A to P substitutions at amino acid positions 397 and 400, respectively, and all but one had T to N substitutions at position 333 ((Table 2.1). In Subgroup 2, all six members had V to I substitutions at position 338. All six isolates in Subgroup 3, which contained the highest proportion of clover isolates, were characterized by I to V, S to T, Y to F, and M to L at amino acid positions 301, 347, 409, and 425 of their N-RTDs, respectively. The C-RTD sequences of isolates Wisc3 and Wisc4 were distinctly different from the rest of the Midwestern SbDV isolates.

Values of ω significantly less than 1.0 indicate that the site is potentially under purifying selection. Analysis of the distribution of nonsynonymous and synonymous substitutions identified 49 amino acid positions with ω values greater than 1.0. Of these, eight positions (372, 409, 425, 457, 475, 480, 494, and 534, (Table 2.1) in the middle of the RTD had lower confidence limits greater than 1.0 and posterior probabilities of less than 0.01, which strongly suggested that these eight positions were under positive selection in the SbDV isolates analyzed.

Transmission of SbDV by *A. glycines*

To study the SbDV transmission by *A. glycines*, a red clover isolate, ClAgt1, was transmitted from clover to Shiroturunoko soybean seedlings by clover aphids. Six out of 14 soybean plants

were infected with SbDV. The *A. glycines* transmitted SbDV from these infected Shiroturunoko plants to three out of five Wayne seedlings. The sequencing of a portion of RTP using SbDV-specific primer confirmed the isolate in Wayne seedlings transmitted by *A. glycines* was ClAgt1. Further trials on this isolate with large numbers of Itachi and Koganejiro plants showed transmission rates ranging from 0 to 55% in the four trials (Table 2.3). These two soybean genotypes were selected because they had consistently high incidences of SbDV infection in Japanese field trials (Banba *et al.*, 1986). The overall rate of transmission of ClAgt1 by *A. glycines* was 23% for the 171 plants analyzed, which showed the inefficient transmission by *A. glycines*.

Analysis of adaptational mutations

The analysis of RTP sequences after one month of adaptation to soybean revealed two nucleotide changes at positions 4501 and 5086 in RTP encoding ORF5 of CIIL4 isolate. The nucleotide sequence changes did not alter the amino acid sequences of the RTP.

DISCUSSION

Analysis of the nucleotide and predicted amino acid sequences of RTP indicated that the major CPs were highly conserved while the minor capsid proteins (RTD) were susceptible to mutation. The C-RTD amino acid sequences were more diverse than the N-RTD. These results are similar to those reported previously for Japanese SbDV isolates (Terauchi *et al.*, 2001; 2003). Phylogenetic analysis revealed that Midwestern isolates were most closely related to Japanese SbDV-DP strains that are transmitted by *A. pisum*. In Japan, DP isolates are rarely found in soybean fields, while YS isolates are commonly isolated from diseased soybean plants (Terauchi *et al.*, 2003). Similarly, the incidence of infection of dwarfing isolates of SbDV in soybean fields in Illinois in 2006 was very low (~0.3%).

Soybean isolates Wisc3 and Wisc4 had predicted amino acid sequences in their RTDs that differentiated them from other SbDV isolates. This difference could indicate an alternative primary host for these isolates. The importance of the luteovirid N-RTDs in vector specificity

has been the subject of multiple studies. Most recently, Peter *et al.* (2008) introduced 14 different three-amino-acid deletions into the N-RTD of *Potato leafroll virus*. None of the mutants were aphid transmissible underscoring the importance of this region in vector specificity. Previous studies on Japanese isolates of SbDV suggested amino acid sequences in N-RTD could be responsible for aphid transmission specificity (Terauchi *et al.*, 2003). The amino acid changes observed in our study may indicate adaptive mutations in the viral genome to different host or vector populations.

The adaptational mutation analysis revealed no amino acid changes in the RTP of the SbDV isolate, CILL4, as a result of transmission through clover aphid and adaptation to soybean. The clover aphid is an efficient vector of both Japanese and North American dwarfing isolates of SbDV (Honda, *et al.*, 1999; Harrison *et al.*, 2005). It is capable of transmitting the virus from red clover to nearby soybean plants growing along borders of soybean fields without colonizing them. This might be a reason why there was no mutation in the RTP of the virus isolate that is involved in the aphid transmission. Trials with an inefficient vector aphid like *A. glycines* or many numbers of transmissions from plant to plant or longer duration in soybeans may introduce adaptational mutation in this particular isolate. Also, trials with more isolates are needed since the relationship between luteoviruses and vector aphids are often highly specific.

In this study, *A. glycines* reproducibly transmitted a Midwestern isolate of SbDV at low efficiency. Similar to the results reported here, previous studies have reported either no or low efficiency transmission of SbDV by *A. glycines* (Tamada *et al.*, 1969; Tamada, 1975; Honda, 2001; Damsteegt *et al.*, 2005; Harrison *et al.*, 2005; Wang *et al.*, 2006). In northern Japan where SbDV incidence can be high, *A. solani* is the principal vector for the virus. *Aulacorthum solani* lays eggs and overwinters on red and white clover plants, many of which are infected with SbDV (Banba *et al.*, 1986; Honda, 2001). In spring, viruliferous alatae migrate from clover to soybean, where feeding by viruliferous aphids leads to SbDV infections. The disease is spread within fields by apterae throughout the summer, until sexual forms emerge in autumn and migrate back to clover to lay eggs and complete their life cycle.

The low incidence of SbDV in US soybean fields is surprising given the high incidence of SbDV in clover plants next to soybean fields. The observation from Japanese soybean dwarf illustrates the importance of aphid phenology in the epidemiology of the disease. In North America, *A. glycines* uses buckthorn (*Rhamnus cathartica* and *R. alnifolia*) as primary hosts and soybean as its principal secondary host (Ragsdale *et al.*, 2004). In early spring, there is a gap between the time alatae emigrate from buckthorn and the appearance of soybean seedlings in production fields. During this time, *A. glycines* could visit red clover and acquire SbDV. Even though *A. glycines* will colonize red clover in the lab, there is no evidence that the aphid overwinters on red clover (Hill *et al.*, 2004). When soybeans senesce in the fall, *A. glycines* develops sexual forms that migrate back to buckthorn, lay eggs and complete its life cycle. Hence, even though *A. glycines* can transmit at least some Midwestern SbDV isolates and diversity exists within the RTDs of the viruses that could provide differences in transmission efficiency and/specificity, the importance of *A. glycines* as a vector of SbDV will probably be limited, as in its native range, by its phenology.

REFERENCES

- Banba, H., Tanimura, Y. and Matuskawa, I. 1986. Breeding for resistance to soybean dwarf virus in soybeans. *Trop. Agric. Res. Ser.* 19:236-246.
- Brault, V., Mutterer, J., Scheidecker, D., Simmonis, M.T., Herrbach, E., Richards, K. and Ziegler-Graff, V. 2000. Effects of point mutations in the readthrough domain of beet western yellows virus minor capsid protein on virus accumulation in planta and on transmission by aphids. *J. Virol.* 74:1140-1148.
- Brault, V., Pfeffer, S., Erdinger, M., Mutterer, J. and Ziegler-Graff, V. 2002. Virus induced gene silencing in transgenic plants expressing the minor capsid protein of *Beet western yellows virus*. *Mol. Plant Microbe Interact.* 15:799-807.
- Brault, V., Van den Heuvel, J. F., Verbeek, M., Ziegler-Graff, V., Reutenauer, A., Herrbach, E., Garaud, J. C., Guilley, H., Richards, K. and Jonard, G. 1995. Aphid transmission of beet western yellows luteovirus requires the minor capsid read-through protein P74. *EMBO J.* 14:650-659.
- Bruyere, A., Brault, V., Ziegler-Graff, V., Simmonis, M. T., Van den Heuvel, J. F., Richards, K., Guilley, H., Jonard, G. and Herrbach, E. 1997. Effects of mutations in the beet western yellows virus readthrough protein on its expression and packaging and on virus accumulation, symptoms, and aphid transmission. *Virology* 230:323-334.

- Cheng, S.L., Domier, L.L. and D'Arcy, C.J. 1994. Detection of the readthrough protein of barley yellow dwarf virus. *Virology* 230:323-334.
- Damsteegt, V. D., Stone, A. L., Russo, A. J., Luster, D. G., Gildow, F. E. and Smith, O. P. 1999. Identification, characterization, and relatedness of luteovirus isolates from forage legumes. *Phytopathology* 89:374-379.
- Damsteegt, V. D., Stone, A.L., Schneider, W., Sherman, D., Gildow, F. and Luster, D. 2005. The soybean aphid, *Aphis glycines*, a new vector of endemic dwarfing and yellowing isolates of soybean dwarf luteovirus. *Phytopathology* 95:S22.
- Domier, L.L., Thekke Veetil, T. and Barta, A. 2005. Complete nucleotide sequence of a Wisconsin soybean isolate of *Soybean dwarf virus*. *Phytopathology* 95:S25.
- Domingo, E. and Holland, J.J. 1997. RNA virus mutations and fitness for survival. *Ann. Rev. Microbiol.* 51:151-178.
- Filichkin, S.A., Lister, R.M., McGrath, P.F. and Young, M.J. 1994. *In vivo* expression and mutational analysis of the barley yellow dwarf virus readthrough gene. *Virology* 205:290-299.
- Gildow, F. E., Damsteegt, V. D., Stone, A. L., Smith, O. P. and Gray, S. M. 2000. Virus-vector cell interactions regulating transmission specificity of soybean dwarf luteoviruses. *J. Phytopathol.* 148:333-342.
- Gray, S. and Gildow, F. E. 2003. Luteovirus-aphid interactions. *Annu. Rev. Phytopathol.* 41:539-566.
- Guilley, H., Wipf-Scheibel, C., Richards, K., Lecoq, H. and Jonard, G. 1994. Nucleotide sequence of cucurbit aphid borne yellows luteovirus. *Virology* 202:1012-1017.
- Harrison, B., Steinlage, T.A., Domier, L.L. and D'Arcy, C.J. 2005. Incidence of *Soybean dwarf virus* and identification of potential vectors in Illinois. *Plant Dis.* 89:28-32.
- Higgins, D. G., Bleasby, A. J. and Fuchs, R. 1992. CLUSTAL V: improved software for multiple sequence alignment. *Comput. Appl. Biosci.* 8:189-191.
- Hill, C.B., Li, Y. and Hartman, G.L. 2004. Resistance to the soybean aphid in soybean germplasm. *Crop Sci.* 44:98-106.
- Honda, K. 2001. Aphids and their transmission of viruses on soybeans in Japan. *Agrochemicals Japan* 79:2-7.

- Honda, K., Kanematsu, S. and Mikoshiya, Y. 1999. Dwarfing strain of soybean dwarf luteovirus transmitted by *Nearctaphis bakeri* and *Acyrtosiphon pisum*. *Ann. Phytopathol. Soc. Jap.* 65:387.
- Johnstone, G.R., Liu, H. and Duffus, J.E. 1984. First report of subterranean clover red leaf virus in the western hemisphere. *Phytopathology* 74:795.
- Jolly, C.A. and Mayo, M.A. 1994. Changes in the amino acid sequence of the coat protein readthrough domain of potato leaf roll luteovirus affect the formation of an epitope and aphid transmission. *Virology* 201:182-185.
- McGrath, E.E., Lister, R. M. and Hunter, B. G. 1996. A domain of the readthrough protein of Barley yellow dwarf virus (NY-RPV isolate) is essential for aphid transmission. *European J. Plant Pathol.* 102:671-679.
- Nicholas, K.B., Nicholas, H.B. and Deerfield, D.W. 1997. GeneDoc: analysis and visualization of genetic variation. *EMBNW.News* 4:14.
- Peter, K. A., Liang, D., Palukaitis, P. and Gray, S. M. 2008. Small deletions in the potato leafroll virus readthrough protein affect particle morphology, aphid transmission, virus movement and accumulation. *J. Gen. Virol.* 89:2037-2045.
- Phibbs, A., Barta, A. and Domier, L. L. 2004. First report of *Soybean dwarf virus* on soybean in Wisconsin. *Plant Dis.* 88:1285.
- Ragsdale, D. W., Voegtlin, D. J. and O'Neil, R. J. 2004. Soybean aphid biology in North America. *Ann. Entomol. Soc. Amer.* 97:204-208.
- Rathjen, J. P., Karageorgos, L. E., Habili, N., Waterhouse, P. M. and Symons, R. H. 1994. Soybean dwarf luteovirus contains the third variant genome type in the luteovirus group. *Virology* 198:671-679.
- Stern, A., Doron-Faigenboim, A., Erez, E., Martz, E., Bacharach, E. and Pupko, T. 2007. Selecton 2007: advanced models for detecting positive and purifying selection using a Bayesian inference approach. *Nucleic Acids Res.* 35:W506-W511.
- Tamada, T. 1970. Aphid transmission and host range of soybean dwarf virus. *Ann. Phytopathol. Soc. Japan* 36:266-274.
- Tamada, T. 1975. Studies on the soybean dwarf disease. *Rep. Hokkaido Perfect Agric. Exp. Stn.* 25:1-144.
- Tamada, T., Goto, K., Chiba, I. and Suwa, T. 1969. Soybean dwarf, a new virus disease. *Ann. Phytopathol. Soc. Japan* 35:282-285.

- Tamura, K., Dudley, J., Nei, M. and Kumar, S. 2007. MEGA4: Molecular Evolutionary Genetics Analysis (MEGA) software version 4.0. *Molec. Biol. Evol.* 24:1596-1599.
- Terauchi, H., Honda, K., Yamagishi, N., Kanematsu, S., Ishiguro, K. and Hidaka, S. 2003. The N-terminal region of the readthrough domain is closely related to aphid vector specificity of *Soybean dwarf virus*. *Phytopathology* 93:1560-1564.
- Terauchi, H., Kanematsu, S., Honda, K., Mikoshihara, Y., Ishiguro, K. and Hidaka, S. 2001. Comparison of complete nucleotide sequences of genomic RNAs of four *Soybean dwarf virus* strains that differ in their vector specificity and symptom production. *Arch. Virol.* 146:1885-1898.
- Thekkeveetil, T., Hobbs, H.A., Wang, Y., Kridelbaugh, Donnelly, J.E., Hartman, G.L. and Domier, L.L. 2007. First report of *Soybean dwarf virus* in soybean in Northern Illinois. *Plant Dis.* 91:1686.
- Van den Heuvel, J.F.J.M., Bruyere, A., Hogenhout, S.A., Ziegler-Graff, V., Brault, V., Verbeek, M., Van der Wilk, F. and Richards, K. 1997. The N-terminal region of the luteovirus readthrough domain determines virus binding to *Buchnera* GroEL and is essential for virus persistence in the aphid. *J. Virology* 71:7258-7265.
- Wang, R.Y., Kritzman, A., Hershman, D.E. and Ghabrial, S.A. 2006. *Aphis glycines* as a vector of persistently and nonpersistently transmitted viruses and potential risks for soybean and other crops. *Plant Dis.* 90:920-926.

Table 2.2. Sequences of oligonucleotide primers used to determine nucleotide sequences of regions encoding *Soybean dwarf virus* readthrough proteins.

Primer name	Primer sequence	Location (nt)	Strand
2563F	5'-AGGACAAACTCGGGCTCAGGAAAG-3'	2563-2586	+
3248F	5'-GGA ACTATCACTTTCGGGCCG-3'	3250-3270	+
3847F	5'-CGCAATGGTACTCACAGAATT-3'	3848-3868	+
4571F	5'-TGCTGATGTCATGAAGTTCTCC-3'	4569-4590	+
5234R	5'-GGATATGCAACCGAAAGTGATA-3'	5252-5231	-
4786R	5'-CCYCGGGAGACAAAGTGT-3'	4784-4767	-
4163R	5'-CCAGTAGTTACTAAATGAAACGAG-3'	4186-4163	-
3529R	5'-GGTCTTCACTGGTATCSTGCC-3'	3529-3509	-

Table 2.3. Transmission of *Soybean dwarf virus* isolate ClAgt1 by *Aphis glycines*.

Line	Trial			
	1	2	3	4
Koganejiro (PI317335)	4/10	3/13	7/65	0/29
Itachi (PI229324)	ND ^a	4/11	6/11	1/32

^a Not determined.

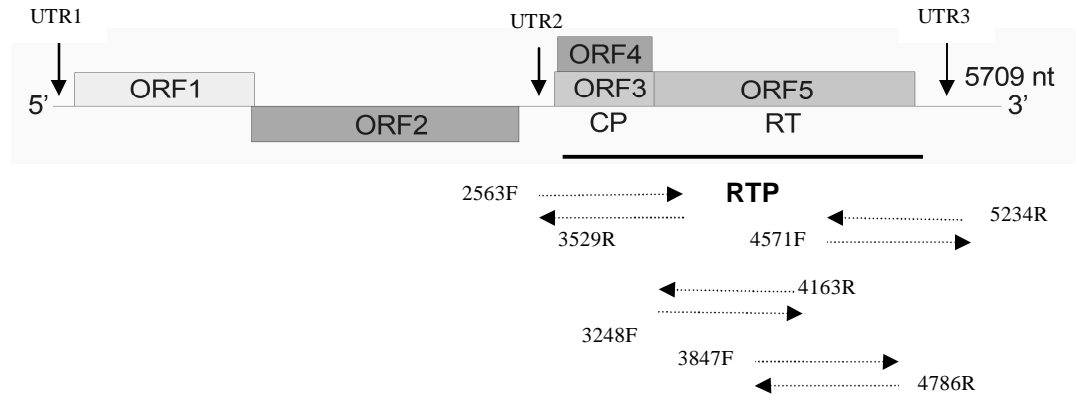

Figure 2.1. Genomic map and sequencing strategy for *Soybean dwarf virus* readthrough protein (RTP) encoding regions. The positions of open reading frames (ORFs) and untranslated regions (UTRs) are indicated. The relative positions and directions of the primers used to sequence the regions encoding coat protein (CP) and readthrough (RT) are shown below the genomic map.

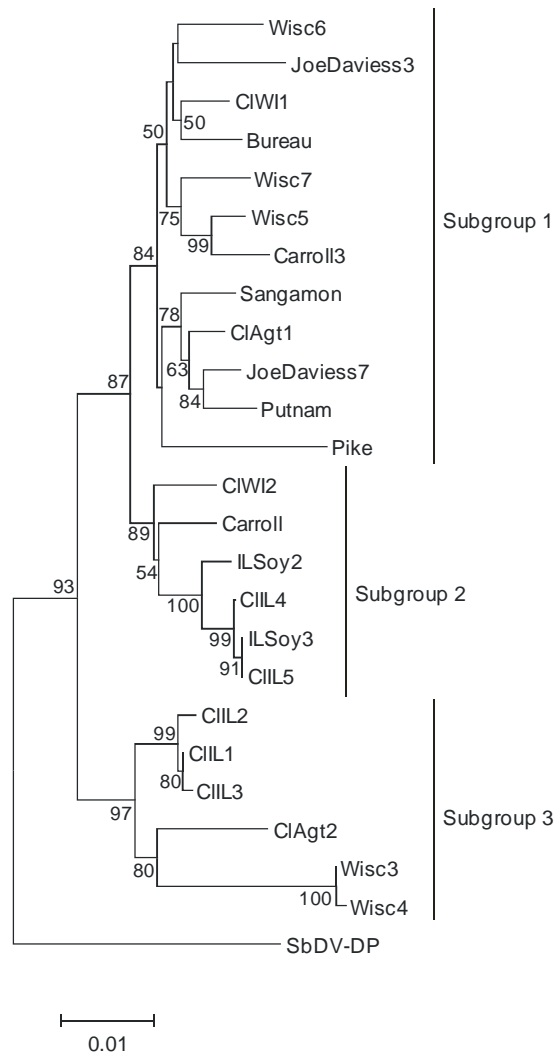

Figure 2.2. Phylogenetic analysis of *Soybean dwarf virus* (SbDV) isolates collected from clover and soybean from Illinois and Wisconsin from 2003 through 2007. The Neighbor-joining tree was constructed and displayed using MEGA 4.0. The nucleotide sequence of SbDV-DP was included as an outgroup.

CHAPTER 3

CONSTRUCTION AND EVALUATION OF INFECTIVITY AND TRANSMISSIBILITY OF FULL-LENGTH cDNA CLONES OF *SOYBEAN DWARF VIRUS*

ABSTRACT

Soybean dwarf virus (SbDV), a *Luteovirus*, is exclusively phloem limited and transmitted only through aphid vectors. As mechanical inoculation is not possible in luteovirids, an agroinfection method was developed for SbDV to introduce the virus into plants. Full-length viral genomes of clover (CIIL2) and soybean (Wisc4 [W4]) isolates were cloned into a modified pCAMBIA 1302 vector, and introduced into a disarmed *Agrobacterium tumefaciens*-strain KYRT1. Replication of both SbDV isolates was detected in agroinfiltrated leaves of *Nicotiana benthamiana*, *N. clevelandii*, black-eyed pea, fava bean and 'Puget' pea seedlings. Systemic infection was observed only with the CIIL2 isolate when the virus was agroinjected into veins, petioles and stems of *N. benthamiana*, red clover, fava bean and 'Puget' pea. For the W4 isolate, infections were restricted to infiltrated leaves. Attempts to transfer the progeny virus from either locally or systemically infected tissues were not successful with different aphid vectors.

INTRODUCTION

Soybean dwarf virus (SbDV) is a phloem limited luteovirus, which is transmitted by aphid vectors. As luteoviruses occur in very low concentrations and only infect phloem-associated tissues of plants, they are not mechanically transmissible, and alternative methods have been adopted to transmit recombinant luteovirids without aphid vectors. Another luteovirid, *Potato leafroll virus* (PLRV), was mechanically transmissible when co-inoculated with a helper virus, *Pea enation mosaic virus-2* (*Umbravirus*) (Mayo *et al.*, 2000; Ryabov *et al.*, 2001). Biolistic inoculation has been successful in introducing PLRV and *Beet western yellows virus* (BWYV) (*Polerovirus*) in *Nicotiana* sp. (Hoffman *et al.*, 2001) and *Barley yellow dwarf virus*-PAV

(*Luteovirus*) in wheat (Helloco-Kervarrec *et al.*, 2002) and SbDV in soybean (Yamagishi *et al.*, 2006).

Agrobacterium tumefaciens is a soil borne pathogenic bacteria that infects plants primarily through wounded roots and stems and causes crown galls (Smith and Townsend, 1907). Infection at wounding sites by *Agrobacterium* results in transfer, integration and expression of T-DNA into plant cells (Nester *et al.*, 1984). Transient expression of foreign genes through T-DNA mediated delivery of *Agrobacterium* is a rapid method to analyze genes and gene products in plants. The system does not require regeneration of transgenic plants and is an efficient method for the introduction of multiple genes simultaneously into leaf tissue (Johansen and Carrington, 2001).

The development of infectious cDNA clones of viral genomes and their use in reverse genetics have facilitated understanding of the biology of many RNA viruses. *Agrobacterium*-based binary vectors have been widely used for delivering infectious full-length copies of viral genomes, inserted in the T-DNA region of the plasmids, into the plants. The method has been used to infect plants with both DNA (Grimsley *et al.*, 1987) and RNA viruses (Leiser *et al.*, 1992; Chiba *et al.*, 2006) and even viruses with bipartite genomes (Ratcliff *et al.*, 2001; Liu and Lomonosoff, 2002). Application of this technology has also been used for reverse genetics studies of some phloem-limited viruses (Grimsley *et al.*, 1987; Leiser *et al.*, 1992). Agroinfection is usually performed by leaf infiltration or injection of stem or petioles. Agrodrench (drenching soil with *Agrobacterium* harboring recombinant viruses; Ryu *et al.*, 2004) and vacuum infiltration (Clough and Bent, 1998) also have been used to infect large numbers of plants or plants that are very young and difficult to inoculate. Although agroinfection of plants with poleroviruses was reported (Leiser *et al.*, 1992; Pruffer *et al.*, 1995; Pruffer *et al.*, 1997; Stevens and Vigano, 2007), there have been no reports on successful agroinfection at the whole plant level in *Luteovirus* genus. In this study, construction of infectious full-length clones of dwarfing isolates of SbDV and development of an agroinfection system to introduce the virus into plants are reported.

MATERIALS AND METHODS

Construction of full-length infectious clones of SbDV

Synthesis of full-length cDNA

To construct full-length infectious clones of SbDV, total RNA was extracted using Trizol Reagent (Invitrogen, Carlsbad, CA) from SbDV-infected soybean (Wisc4 [W4] isolate) and red clover (*Trifolium pratense*; CIIL2 isolate) plants. Total RNA was reverse transcribed with Superscript II reverse transcriptase (Invitrogen) and 0.1 μ m reverse primer 5688R (5'-GAGAGACCCCGGGCAGGTGGA-3') that added a *SmaI/XmaI* restriction site (underlined) at the 3' end of the SbDV genome. The single stranded cDNA was then amplified with primers 5688R and, 1F (5'-AGTAAAGTTGACACCTTTACAGAAGTG-3'), and Ex *Taq*, a proof reading DNA polymerase (Takara Mirus Bio, Madison, WI) with 40 cycles of 94°C for 30 s, 55°C for 30 s, 72°C for 6 min in a PTC-200 thermocycler (MJ Research, Waltham, MA). The reverse transcription polymerase chain reaction (RT-PCR) products were electrophoresed in 1% agarose gel at 100V for 30 min and analyzed by ethidium bromide staining.

Plasmid vector

The plasmid pCAMBIA1302 was modified for agroinoculation of SbDV clones. This is a high copy number plasmid with a pBR322 origin of replication and kanamycin resistance gene as the bacterial selectable marker. The hygromycin resistance gene in pCAMBIA1302 was replaced with the cloning cassette from pHST40 (Scholthof *et al.*, 1992) (Figure 3.1), containing a doubled *Cauliflower mosaic virus* (CaMV) 35S promoter, a multicloning site, a *Hepatitis delta virus* antigenomic ribozyme (HDVagrz) to generate 3' termini resembling those of native SbDV RNA (Pattnaik, *et al.*, 1992), and nopaline synthase poly A (NOS poly A) signal for *in vivo* termination of transcription and polyadenylation. The plasmid retained the green fluorescent protein (GFP) reporter gene, and the resulting plasmid was named pCZ14. The vector also contains right and left border sequences of T-DNA for *Agrobacterium* mediated delivery into plants (Figure 3.2).

Cloning of SbDV genome into the plasmid vector

The 5.7 kb RT-PCR products of soybean and clover SbDV isolates were gel purified using a QIAquick Gel Extraction Kit (Qiagen Inc. Valencia, CA) (Figure 3.2). The products were first cloned into pCR[®]-XL-TOPO[®] (Invitrogen) according to the manufacturer's protocol. *Escherichia coli* cells (DH 10B) were transformed with the TOPO-cloned vector by electroporation (Electroporator 2510, Brinkmann Instruments Inc., NY), plated and colonies were screened on Luria-Bertani (LB) plates with kanamycin (30 mg/l). The transformation, cloning and screening techniques were adopted from Sambrook and Russell (2001). Plasmids isolated from kanamycin resistant colonies were confirmed to contain full-length SbDV genome by *EcoRI* digestion.

A 300-bp PCR fragment containing a *SalI* site was synthesized using primers 1F and 300R (5'-CCATACATGGCGTCGTAGCA-3') and high fidelity iProof polymerase (Bio-Rad, Hercules, CA) with the following thermal cycling program: 98°C for 30 s followed by 35 cycles of 98°C for 8 s, 59°C for 20 s and 72°C for 15 s. The blunt-ended PCR product was then digested with *SalI* (recognition site at position 277 in the SbDV genome) and ligated into *StuI* and *SalI* linearized pCZ14 downstream of the doubled CaMV 35S promoter (Figure 3.2). The *E. coli* cells were transformed with the ligation mixture and colonies were screened by plasmid extraction and digestion with restriction enzymes, *XbaI* and *HindIII*. The plasmid with insert was then sequentially digested with *XmaI* and *SalI*. The TOPO-cloned full-length SbDV genome was also digested with *XmaI* and *SalI* and the required 5.5 kb size fragment was gel recovered (Qiagen Inc. Valencia, CA) and ligated to *XmaI* and *SalI* linearized pCZ14 with 277-bp fragment of the SbDV genome. Plasmids from transformed *E. coli* colonies were screened with restriction enzymes *HindIII* and *EcoRI*. Presence of intact 5' and 3' ends of the genome was verified by sequencing the plasmids with pCam 8877F (5'-CTGGGAAGTACTCACACATTATTATGGAGA-3') and 300R.

Agroinoculation

Transformation and preparation of Agrobacterium

Agrobacterium tumefaciens strain KYRT1 cells were transformed with clones of the soybean and clover SbDV isolates by electroporation. The plasmids were purified by QIAprep Spin Miniprep Kit (Qiagen) and digested with *Hind*III and *Eco*RI to verify the incorporation of the binary plasmid. In addition to *A. tumefaciens*, these clones were also introduced into *A. rhizogenes* (strain K599) for inoculation into plants. *Agrobacterium* harboring the binary vectors was then cultured at 28°C on LB agar medium plates. Bacterial cells were harvested by scraping them from the solid media using an inoculation loop and resuspending them in infiltration buffer containing 10 mM MgCl₂, 10 mM MES (2-[N-morpholino] ethane sulfonic acid), pH 5.6 and 150 µM acetosyringone to an absorbance value of 1.0 at OD 600 in a spectrophotometer (GeneQuant Pro, Biochrom Ltd, Cambridge, UK).

Cultivation of Nicotiana benthamiana plants for agroinoculation

Seeds of *Nicotiana benthamiana* were germinated in soilless media (Sunshine professional growing mix, LCI) at 22 to 25°C with high light intensity (17,222 µmolm⁻²s⁻¹) in growth chambers. Transparent plastic trays were used to cover pots to provide adequate moisture for germination. After germination, the trays were removed and plants were thinned to 4 plants/ pot, fertilized weekly and allowed to grow until they reached eight leaves stage (one month old).

Agroinoculation

Agrobacterium harboring binary vectors expressing the viral suppressor of posttranscriptional gene silencing (P19 from *Tomato bushy stunt virus* or helper-component protease (HC-Pro) from *Tobacco etch virus*) were co-infiltrated with *Agrobacterium* harboring SbDV in order to prevent silencing in plants that would suppress the expression of the cloned viral genomes (Chiba *et al.*, 2006). Co-expression of viral genome with silencing suppressors through agroinoculation helped to overcome silencing activities of the plants and increased the infectivity of the virus up to 10,000 fold (Chiba *et al.*, 2006). Initial trials were performed with either P19 or HC-Pro, but

in later attempts only P19 was used as there was no difference in efficiency for agroinfection by these two suppressors. *Agrobacterium* harboring the binary plasmid containing the P19 gene was also cultured and prepared in the same way and mixed with *Agrobacterium* harboring SbDV in a 1:1 ratio and incubated at room temperature for one hr before the agroinoculation.

Multiple methods for agroinfection and different plant species (*Arabidopsis thaliana*, bengal gram (*Cicer arietinum*), black-eyed pea (*Vigna unguiculata*), fava bean (*Vicia faba*), french bean (*Phaseolus vulgaris*), mung bean (*Vigna radiata*), *N. benthamiana*, *N. clevelandii*, 'Puget' pea (*Pisum sativum*), red clover and soybean) were evaluated in an attempt to produce systemic infections with SbDV clones (Tables 3.1 - 3.6). For leaf infiltrations, the mixed culture was infiltrated to the abaxial leaf epidermis of *N. benthamiana* with a 1 ml needleless syringe. Also, the veins, petioles and stem were injected with the *Agrobacterium* suspension. Nodal injection of plants was performed as described by Estrada-Navarrete *et al.* (2006). The plants were immediately transferred to growth chambers (temperature 18-20°C) after the treatments. Expression of the T-DNA in *N. benthamiana* was confirmed by fluorescence of the GFP under UV light after 3 - 4 days of infiltration.

For agrodrench, the basal part of the stem near the soil was pricked with a needle, and 3 - 5 ml of *Agrobacterium* suspension was drenched into the crown part of the plant (Ryu *et al.*, 2004). Soil drench was performed with both *A. tumefaciens* and *A. rhizogenes*. For sprouted seed treatment, hypocotyls of the germinated seeds were pricked with needle and immersed in *Agrobacterium* suspension for 16 - 18 hr and planted in soil. For vacuum infiltration, *Agrobacterium* cells were resuspended in 5% sucrose, 0.01% Silwet-L77 (Clough and Bent, 1998) in infiltration buffer. Plants were infiltrated by submerging them in infiltration media in a vacuum chamber and applying vacuum until the media started to boil.

Seedlings of soybean cv. Jack (comparatively easy to transform) and *Soybean mosaic virus* (SMV)-infected cvs. Jack, Koganejuro, Mumford, Shiroturunoko, Wayne, Williams and Yuzuru were evaluated. SMV-infected Jack was selected based on the synergism observed in mixed infection of a luteovirus (PLRV) with a potyvirus (*Potato virus A*) and that the combination

partially alleviated phloem limitation of PLRV and helped it to spread to neighboring cells (Savenkov and Valkonen, 2001).

Biolistic inoculation

In addition to agroinfection, a biolistic inoculation method using a gene gun was also evaluated for the production of systemically infected plants. Gold particles were coated with either plasmid DNA or *in vitro* transcribed viral RNAs and bombarded onto cotyledon- and unifoliate-stage soybean seedlings (Jack, SMV-infected Jack and Williams), and *A. thaliana* and *N. benthamiana* plants. Full-length clover and soybean SbDV PCR products were amplified from cDNA using *PacI* T7F (5'-
GAGATTAATTAATAACGACTCACTATAGAGTAAAGTTGACACCTTTACAGAAGTG-3') (T7 polymerase promoter underlined) and 5688R primers and high fidelity iProof polymerase with the following thermocycler program: 98°C for 30 s followed by 35 cycles of 98°C for 8 s, 70°C for 20 s and 72°C for 3 min. The PCR products were gel purified to get a single full-length band and RNA was *in vitro* transcribed according to the manufacturer's instructions (mMESSAGE mMACHINE Kit, Ambion, Austin, TX). Particle bombardment of *in vitro* transcribed RNA was carried out using the gene gun with a helium pressure of 310 kPa according to Yamagishi *et al.* (2006). Plasmid DNA (pCZ14 with SbDV genome) bombardment was carried out according to two different procedures (Finer *et al.*, 1992; Gal-On *et al.*, 1997).

Aphid transmission from locally and systemically infected agroinoculated plants

Local infection

Infectivity assay of progeny virions of the full-length clones of SbDV was conducted by aphid transmission on both locally and systemically infected plants. For local infections, SbDV virions were purified from 25 g of agroinfiltrated *N. benthamiana* tissue (W4 and CIIL2) by differential centrifugation and were fed by aphids to transmit the virus. Frozen infected leaf tissue was homogenized in 50 ml 0.1 M sodium phosphate buffer (pH 7.0) and 0.1 per cent sodium sulfite and centrifuged at 10,000 rpm for 15 min in a Sorval HB-6 rotor to pellet plant debris. The supernatant was filtered through cheese cloth and stirred for one hr at room temperature after the

addition of PEG 6000 and NaCl to final concentrations of 4% and 0.2 M, respectively. The macromolecules were then precipitated by centrifugation at 10,000 rpm for 15 min. The pelleted virions were resuspended in 0.1 M sodium phosphate buffer and were subjected to high speed centrifugation at 45,000 rpm for 2 hr in a Beckman Ti70 rotor. The virions were resuspended in 0.5 ml 0.1 M sodium phosphate buffer (pH 7.0) and stored at -80°C until use. The virus was also purified from aphid-inoculated, SbDV-infected clover plants (100 g) as a positive control for membrane-feeding (infectivity) assays. The presence of SbDV in purified samples was confirmed by either double-antibody sandwich enzyme-linked immunosorbent assay (DAS-ELISA) or immuno-capture real-time reverse transcription- polymerase chain reaction (IC-qRT-PCR).

Purified virions of soybean and clover SbDV were diluted in 20% sucrose in 0.1 M sodium phosphate buffer (pH 7.0) and 100 µl was applied between two stretched Parafilm membranes. Nonviruliferous spotted clover aphids (*Nearctaphis bakeri*) and soybean aphids (*Aphis glycines*) were allowed to acquire the virus from Parafilm sachets for 24 (*A. glycines*) to 48 (*N. bakeri*) hr and 30 aphids were transferred to each one-week-old unifoliate Koganejiro, Mumford, Shiroturunoko and Wayne seedlings, and caged. A virus-free 20% sucrose solution and a 20% sucrose solution containing SbDV purified from aphid-inoculated red clover tissues were used as negative and positive controls, respectively. Aphids were killed in a chamber with a volatile insecticide after 48 hr of inoculation access. Plants were tested for SbDV infection by DAS-ELISA or IC-qRT-PCR.

Systemic infection

Aphis glycines, green peach aphids (*Myzus persicae*) and *Nearctaphis bakeri* maintained on virus- free soybean, turnip and red clover plants, respectively, were evaluated for their abilities to transmit progeny viruses of CIIL2 isolate from systemically infected agroinjected plants to healthy soybeans. The *N. bakeri* was fed on infected fava bean, 'Puget' pea and red clover leaves, while *A. glycines* and *M. persicae* were fed on *N. benthamiana* leaves for an acquisition access of 24 hr. Thirty aphids of each species were transferred to individual healthy unifoliate

soybean seedlings. Aphids were given an inoculation access as long as they lived on the plants. After 3 - 4 weeks of inoculation, plants were tested for SbDV infection by DAS-ELISA.

Virus detection

Agroinoculated plant samples (both infiltrated and newly emerged leaves) were screened for SbDV infection by multiple methods including, RT-PCR, immuno-capture RT-PCR (IC-RT-PCR), DAS-ELISA and IC-qRT-PCR. Because of the detection of infiltrated *Agrobacterium* plasmid DNA in RT-PCR and IC-RT-PCR assays, IC-qRT-PCR with and without reverse transcriptase and DAS-ELISA were used for routine screening of infiltrated and systemic leaves of agroinoculated plants.

Double-antibody sandwich ELISA (DAS-ELISA)

Leaf samples were ground using a double-roller plant sap extractor (Erich Pollahne, West Germany) in 1 ml general extraction buffer (GEB) (20 mM sodium sulfite, 2% polyvinylpyrrolidone (24-40,000), 2% Tween 20, 0.02 % sodium azide, 0.2% egg albumin, grade II in phosphate buffered saline + Tween 20 (PBST; 20 mM potassium phosphate 150 mM NaCl, 0.05% (w/v) Tween-20, pH 7.2) and tested according to the Agdia (Elkhart, IN) protocol. Absorbance measurements were made on a BioTek model 307 EIA Reader (Dynex Technologies Inc., VA) at 405 nm. SbDV-infected and uninfected plants were included as positive and negative controls, respectively, in all ELISA plates and samples were duplicated. Test wells were rated positive if their mean absorbances exceeded twice the mean absorbance of negative control wells.

Immuno-capture real-time RT-PCR (IC-qRT-PCR)

MicroAmp optical (Applied Biosystems, Foster City, CA) 96-well reaction plates were coated with 50 µl of 0.1% electron microscope grade glutaraldehyde at 65°C for 3 hr. After removing glutaraldehyde from the wells, plates were coated with 50 µl SbDV monoclonal antibody 29D-15 (diluted to 1 µg/ml in 1×PBS) per well and incubated at 4°C overnight. After discarding the

antibody, the wells were rinsed with sterile water and were blocked with 100 µl blocking buffer (0.1% non-fat dry milk in 1×PBS) for one hr at room temperature. Leaf samples, 100 mg, were ground using the double-roller plant sap extractor in 500 µl GEB. The blocking buffer was discarded and 50 µl of a plant extract was dispensed into the well and incubated overnight at 4°C. Plant samples were removed using aero-guard tips and washed with sterile water. Invitrogen master mix I (Superscript III Platinum One Step qRT-PCR Master Mix with ROX) containing 100 nM fluorescently-labeled probe (VIC-AGCATATCCAAAGACGC-MGBNFQ) and 200 nM SbDV primers [2327F (5'-TGGCTATTATAGAATGGTGCGTAAAC-3') and 2395R- (5'-GCCATGGAAATGAGGGAATG-3')] were added and incubated at 70°C for 15 min. To this, Invitrogen master mix II containing Superscript III reverse transcriptase and *Taq* DNA polymerase mixture was added and incubated in a ABI 7900HT qRT PCR machine (Applied Biosystems, Foster City, CA) at 50°C for 5 min and 95°C for 10 min followed by 40 cycles of 95°C for 15 s, and 60°C for 1 min. All samples were duplicated. As controls for amplification from contaminating plasmid DNA, duplicate sets of reactions were set up with Invitrogen PCR Master Mix that did not contain Superscript III reverse transcriptase. Test wells were rated positive if the threshold cycle (Ct) value exceeded the mean Ct plus three standard deviations of the Ct values negative control samples.

RESULTS

Construction of full-length SbDV cDNA clones

Construction of full-length cDNA clones (pCZ14W4 and pCZ14CIIIL2) under the control of the CaMV 35S promoter is described in detail under materials and methods. The insertion of a full-length genome of SbDV into binary vector pCZ14 was confirmed by the presence of the restriction fragments of 2.2 kb, 4.7 kb and 8.4 kb obtained from digestion of transformed *E. coli* plasmids with *Hind*III and *Eco*RI (Figure 3.3). Nucleotide sequence analysis also verified the presence of intact 3' and 5' ends of the viral genome. Restriction analysis of plasmids from *Agrobacterium* transformed with the binary vector containing full-length cDNA clones of SbDV showed digestion patterns indistinguishable from those of plasmids purified from *E. coli* and thus

confirmed the incorporation of the binary vector containing full-length SbDV cDNAs in *Agrobacterium* without rearrangements (Figure 3.3).

Infectivity studies of full-length clones of SbDV

Among the various agroinfection methods described in Tables 3.1-3.6, only leaf infiltration and injection of agrobacterial suspensions into veins, petioles and stem resulted in local and systemic infections, respectively. Leaf infiltration of *Agrobacterium* harboring full-length clones of soybean and red clover SbDV isolates W4 and CIIL2 resulted in local infections in black-eyed pea, fava bean, *N. benthamiana*, *N. clevelandii*, and ‘Puget’ pea leaves that were detected by DAS-ELISA and/or IC-qRT-PCR (Table 3.1). Infiltrated tissues were SbDV-free in *A. thaliana*, bengal gram, french bean, mung bean, and soybean. Virus titers were very high in infiltrated leaves of *N. benthamiana* and ‘Puget’ pea 6 to 7 days after infiltration. With *N. benthamiana*, the use of healthy green plants was found necessary for agroinfection to produce SbDV infections. In such cases, 100% of infiltrated leaves tested were SbDV positive, but systemic infection was not observed in these plants.

When *Agrobacterium* was injected on leaf veins, petioles and stems with the red clover isolate CIIL2, systemic infection of SbDV was observed after 3 to 4 weeks in fava bean, *N. benthamiana*, ‘Puget’ pea and red clover plants (Table 3.2 and Figure 3.4). At least 3 weeks were needed to detect systemic infection in agroinjected plants compared to 6 to 7 days for local infections. Systemically infected *N. benthamiana*, ‘Puget’ pea and red clover plants were symptom free. Stems and petioles of agroinjected fava bean plants became necrotic and plants died 4 to 5 weeks after inoculation. Systemic leaves of plants agroinjected with W4 isolate were SbDV free. Biolistic inoculations of plasmid DNA and *in vitro* transcribed RNAs of SbDV clones were unsuccessful in producing either local or systemic infections in *A. thaliana*, *N. benthamiana* and soybean plants.

Different agroinfection procedures (listed in Tables 3.1-3.6) with *A. tumefaciens* and *A. rhizogenes*, and biolistic inoculation with clones of both soybean (W4) and clover isolates (CIIL2) were unsuccessful in producing either local or systemic infection in soybeans. Formation

of adventitious roots and root hairs from sites where the stems were pricked with needles was observed in the case of soil drenching and nodal stem injection of soybeans with *A. rhizogenes*. However, neither the roots nor systemic young leaves were infected with SbDV.

Aphid transmission studies on agroinfected plants

To study the infectivity of the progeny virus from full-length clones of SbDV, aphid transmission was conducted on virus purified from *N. benthamiana* leaves agroinfiltrated with W4 and CIIL2 isolates and on plants systemically infected with the CIIL2 isolate. Although the purified virus aliquots from agroinfiltrated tissues tested highly positive in both DAS-ELISA and IC-qRT-PCR, no local (the unifoliate leaf on which the aphids were placed) or systemic infection was observed in soybean plants inoculated with aphids that were fed with the purified virus of either W4 or CIIL2 isolates (Table 3.7). Transmission of CIIL2 isolate of SbDV from systemically infected fava bean, *N. benthamiana*, ‘Puget’ pea and red clover plants to soybeans with *A. glycines*, *M. persicae*, and *N. bakeri* was also unsuccessful in repeated trials (Table 3.8).

DISCUSSION

Full-length clones of SbDV constructed from both W4 and CIIL2 isolates were infectious in infiltrated tissues of black-eyed pea, fava bean, *N. clevelandii*, *N. benthamiana*, and ‘Puget’ pea as indicated by positive DAS-ELISA and IC-qRT-PCR. Among the different agroinfection methods performed, only agroinjection of CIIL2 isolate into stems, veins and petioles was successful in producing systemic infection in fava bean, *N. benthamiana*, ‘Puget’ pea and red clover. Compared to leaf infiltration, injection of leaf veins, petioles and stems might have introduced the virus successfully in phloem cells leading to systemic infections.

As SbDV coat protein (CP) is synthesized from a subgenomic RNA that is transcribed from negative sense viral RNA, the detection of SbDV CP by DAS-ELISA indicated that SbDV replicated in infiltrated mesophyll tissues. Upon mechanical inoculation, luteoviruses are capable of replicating in mesophyll cells, but their movement to phloem from infiltrated tissues is limited either due to failure to overcome the RNA silencing outside of phloem tissues (Voinnet *et al.*,

1999) or inability of luteovirid movement proteins to function in non-vascular tissues (Taliensky *et al.*, 2003). Also, a recent study on PLRV suggested that the open reading frame (ORF) 5-encoded readthrough protein (RTP) is responsible for the phloem limitation of luteovirids (Peter *et al.*, 2009).

Unlike the CIIL2 isolate, repeated trials of agroinjection of soybean isolate W4 into veins, petioles and stems failed to produce systemic infections in fava bean, *N. benthamiana*, 'Puget' pea and red clover plants. Purification of virions from W4 infiltrated leaf tissues and detection of the virus by DAS-ELISA indicated that W4 was capable of replication and formation of virus particles. The lack of systemic movement could be either isolate-specific or due to a mutation in the W4 movement protein that restricts viral movement out of the infiltrated/injected tissues. The previous study on sequence diversity of RTPs of several SbDV isolates revealed that W4 is a unique isolate that differed at many amino acid positions in comparison to the rest of the SbDV isolates. The W4 and CIIL2 isolates differed at 17 amino acid positions (Table 3.9) in the RTP sequences. It is possible that some of these mutations also could be responsible for the lack of systemic spread to a detectable level in this particular isolate. The RTP was shown to be involved in systemic movement and accumulation of virus in plant hosts in other luteovirids (Chay *et al.*, 1996; Bruyere *et al.*, 1997; Mutterer *et al.*, 1999; Brault *et al.*, 2000). Also, in PLRV, RTP was shown to act *in trans* to facilitate long-distance movement of virus in phloem tissues (Peter *et al.*, 2008).

Different agroinfection methods and biolistic inoculation of SbDV clones were not successful in producing viral infection in soybeans. Though agroinjection was successful in fava bean, *N. benthamiana*, 'Puget' pea and red clover, none of the injected soybean plants were infected with SbDV, probably due to poor sensitivity of soybean to *Agrobacterium*-mediated transformation (Dang and Wei, 2007). Because the trials included multiple soybean cultivars, cultivar resistance to SbDV infection is unlikely. In the present study, gene gun inoculation of soybean plants with SbDV cDNA clones in the form of plasmid DNA and *in vitro* transcripts were unsuccessful. In contrast to this result, Yamagishi *et al.* (2006) reported systemic infection of soybean plants with gene gun bombardment of SbDV transcripts.

Attempts to transfer SbDV from both infiltrated tissues and systemically infected leaf tissues to soybean through *A. glycines*, *M. persicae*, and *N. bakeri*, were unsuccessful. It is possible that these cloned isolates are not aphid transmissible. For these studies, it was difficult to find an aphid species that would feed on both soybean and *N. benthamiana* and transmit SbDV.

Full-length infectious clones of many plant RNA viruses have been developed either as *in vitro* transcripts or as cDNA clones and have been used to study the functions of viral genes and interactions between the virus and plants or vectors. In *Luteoviridae*, infectious cDNA clones in plants have been reported mainly in poleroviruses like *Beet mild yellowing virus* (BMYV; Stevens and Viganò, 2007), BWYV (Leiser *et al.*, 1992), *Cucurbit aphid-borne yellows virus* (CABYV; Pruffer *et al.*, 1995), and PLRV (Pruffer *et al.*, 1997). This is the first report of the production of systemically infected plants with a cloned luteovirus in plants through agroinfection. The clone could be used to study the gene expression, replication, movement and packaging of SbDV and its interactions with the host plants. As it is symptom free in *N. benthamiana* and red clover this clone could also be exploited as a viral vector for gene expression studies.

REFERENCES

- Brault, V., Mutterer, J., Scheidecker, D., Simonis, M. T., Herrbach, E., Richards, K. and Ziegler-Graff, V. 2000. Effects of point mutations in the readthrough domain of the beet western yellows virus minor capsid protein on virus accumulation in planta and on transmission by aphids. *J. Virol.* 74:1140-1148.
- Bruyere, A., Brault, V., Ziegler-Graff, V., Simonis, M. T., Van den Heuvel, J. F. J. M., Richards, K., Guilley, H., Jonard, G. and Herrbach, E. 1997. Effects of mutations in the beet western yellows virus readthrough protein on its expression and packaging and on virus accumulation, symptoms, and aphid transmission. *Virology* 230:323-334.
- Chay, C. A., Gunasinge, U. B., Dinesh-Kumar, S. P., Miller, W. A. and Gray, S. M. 1996. Aphid transmission and systemic plant infection determinants of barley yellow dwarf luteovirus-PAV are contained in the coat protein readthrough domain and 17-kDa protein, respectively. *Virology* 219:57-65.
- Chiba, M., Reed, J. C., Prokhnovsky, A. I., Chapman, E. J., Mawassi, M. and Koonin, E. V. 2006. Diverse suppressors of RNA silencing enhance agroinfection by a viral replicon. *Virology* 346:7-14.

- Clough, S.J. and Bent, A.F. 1998. Floral dip: a simplified method for *Agrobacterium*- mediated transformation of *Arabidopsis thaliana*. *The Plant J.* 16:735-743.
- Dang, W. and Wei, Z. 2007. An optimized *Agrobacterium*-mediated transformation for soybean for expression of binary insect resistance genes. *Plant Sci.* 173:381-389.
- Estrada-Navarrete, G., Alvarado-Affantranger, X., Olivares, J.E., Diaz-Camino, C., Santana, O., Murillo, E., Guillen, G., Sanchez-Guevara, N., Acosta, J., Quinto, C., Li, D., Gresshoff, P.M. and Sanchez, F. 2006. *Agrobacterium rhizogenes* transformation of the *Phaseolus spp.*: a tool for functional genomics. *Mol. Plant Microbe Interact.* 19:1385-1393.
- Finer, J., Vain, P., Jones, M. and McMullen, M. 1992. Development of the particle inflow gun for DNA delivery to plant cells. *Plant Cell Rep.* 11:323-328.
- Gal-On, A., Meiri, E., Elman, C., Gray, D. J. and Gaba, V. 1997. Simple hand-held devices for the efficient infection of plants with viral-encoding constructs by particle bombardment. *J. Virol. Methods* 64:103-110.
- Grimsley, N., Hohn, T., Davies, J. W. and Hohn, B. 1987. *Agrobacterium*-mediated delivery of infectious maize streak virus into maize plants. *Nature* 325:177-179.
- Helloco-Kervarrec, C., Riault, G. and Jacquot, E. 2002. Biolistic-mediated inoculation of immature wheat embryos with *Barley yellow dwarf virus-PAV*. *J. Virol. Methods* 102:161-166.
- Hoffmann, K., Verbeek, M., Romano, A., Dullemans, A.M., Van den Heuvel, J.F.J.M. and Van der Wilk, F. 2001. Mechanical transmission of poleroviruses. *J. Virol. Methods* 91:197-201.
- Johansen, L. K. and Carrington, J. C. 2001. Silencing on the spot induction and suppression of RNA silencing in the *Agrobacterium*-mediated transient expression system. *Plant Physiol.* 126:930-938.
- Leiser, R. M., Ziegler-Graff, V., Reutenauer, A., Herrbach, E., Lemaire, O. and Guilley, H. 1992. Agroinfection as an alternative to insects for infecting plants with beet western yellows luteovirus. *Proc. Nat. Acad. Sci. USA* 89:9136-9140.
- Liu, L. and Lomonossoff, G. 2002. Agroinfection as a rapid method for propagating *Cowpea mosaic virus*-based constructs. *J. Virol. Methods* 105:343-348.
- Mayo, M.A., Ryabov, E.V., Fraser, G. and Taliansky, M. 2000. Mechanical transmission of *Potato leafroll virus*. *J. Gen. Virol.* 81:2791-2795.

- Mutterer, J. D., Stussi-Garaud, C., Michler, P., Richards, K. E., Jonard, G. and Ziegler-Graff, V. 1999. Role of the beet western yellows virus readthrough protein in virus movement in *Nicotiana clevelandii*. *J. Gen. Virol.* 80:2771-2778.
- Nester, E.W., Gordon, M.P., Amasino, R.M. and Yanofsky, M.F. 1984. Crown gall: a molecular and physiological analysis. *Annu. Rev. Plant Physiol.* 35:387-413.
- Pattnaik, A.K., Ball, L.A., LeGrone, A.W. and Wertz, G.W. 1992. Infectious defective interfering particles of VSV from transcripts of a cDNA clone. *Cell* 69:1011-1020.
- Peter, K. A., Gildow, F., Palukaitis, P. and Gray, S. M. 2009. The C terminus of the polerovirus P5 readthrough domain limits virus infection to the phloem. *J. Virol.* 83:5419-5429.
- Peter, K. A., Liang, D., Palukaitis, P. and Gray, S. M. 2008. Small deletions in the potato leafroll virus readthrough protein affect particle morphology, aphid transmission, virus movement and accumulation. *J. Gen. Virol.* 89:2046-2054.
- Prufer, D., Schmitz, J., Tacke, E., Kull, B. and Rohde, W. 1997. In vivo expression of a full-length cDNA copy of potato leafroll virus (PLRV) in protoplasts and transgenic plants. *Mol. Gen. Genet.* 253:609-614.
- Prufer, D., Wipf-Scheibel, C., Richards, K., Guilley, H., Lecoq, H. and Jonard, G. 1995. Synthesis of a full-length infectious cDNA clone of cucurbit aphid-borne yellows virus and its use in gene exchange experiments with structural proteins from other luteoviruses. *Virology* 214:150-158.
- Ratcliff, F., Martin-Hernandez, A. M. and Baulcombe, D. C. 2001. Tobacco rattle virus as a vector for analysis of gene function by silencing. *Plant J.* 25:237-245.
- Ryabov, E.V., Fraser, G., Mayo, M.A., Barker, H. and Taliansky, M. 2001. Umbravirus gene expression helps *Potato leafroll virus* to invade mesophyll tissues and to be transmitted mechanically between plants. *Virology* 286:363-372.
- Ryu, C., Anand, A., Kang, L. and Mysore, K. S. 2004. Agrodrench: A novel and effective agroinoculation method for virus-induced gene silencing in roots and diverse solanaceous species. *Plant J.* 40:322-331.
- Sambrook, J. and Russel, D.W. 2001. Molecular cloning- A laboratory manual, 3rd edition, Cold Spring harbor lab press, NY. P. 999.
- Savenkov, E.I. and Valkonen, J.P.T. 2001. Potyviral helper component proteinase expressed in transgenic plants enhances titers of *Potato leaf roll virus* but does not alleviate its phloem limitation. *Virology* 283:285-293.

- Scholthof, H.B., Wu, F.C., Gowda, S. and Shepherd, R.J. 1992. Regulation of caulimovirus gene expression and the involvement of cis acting elements on both viral transcripts. *Virology* 190:403-412.
- Smith, E.F. and Townsend, C.O. 1907. A plant tumour of bacterial origin. *Science* 25:671-673.
- Stevens, M. and Vigano, F. 2007. Production of a full-length infectious GFP-tagged cDNA clone of *Beet mild yellowing virus* for the study of plant–polerovirus interactions. *Virus Genes* 34:215-221.
- Taliansky, M., Mayo, M. A. and Barker, H. 2003. *Potato leafroll virus*: a classic pathogen shows some new tricks. *Mol. Plant Pathol.* 4:81-89.
- Voinnet, O., Pinto, Y. M. and Baulcombe, D. C. 1999. Suppression of gene silencing: A general strategy used by diverse DNA and RNA viruses of plants. *Proc. Nat. Acad. Sci. USA* 96:14147-14152.
- Yamagishi, N., Terauchi, H., Kanematsu, S. and Hidaka, S. 2006. Biolistic inoculation of soybean plants with soybean dwarf virus. *J. Virol. Methods* 137:164-167.

Table 3.1. Inoculation of plants with full-length *Soybean dwarf virus* (SbDV) cDNA clones by leaf infiltration of *Agrobacterium tumefaciens*.

Plant	Stage	Number of infected plants ^a			
		CIIL2 ^b		W4	
		Infiltrated	Systemic	Infiltrated	Systemic
<i>Nicotiana benthamiana</i>	4-5 weeks	99/192	0/101	112/209	0/98
Red clover	4-5 weeks	0/44	0/44	0/23	0/23
Black-eyed pea	Unifoliate	10/12	0/8	34/89	0/80
‘Puget’ pea	1-2 weeks	ND ^c	ND	7/15	0/15
<i>Nicotiana clevelandii</i>	4-5 weeks	3/3	0/3	4/5	0/5
French beans	Unifoliate	ND	ND	0/2	0/2
Mung bean	Unifoliate	0/4	0/4	ND	ND
Bengal gram	2 weeks	0/8	0/8	ND	ND
<i>Arabidopsis thaliana</i>	4-5 weeks	0/9	0/9	0/3	0/3
Soybean	Unifoliate	0/9	0/9	0/4	0/4
Fava bean	1-2 weeks	5/5	0/5	2/10	0/5

^a Infiltrated and systemic leaves were tested either by DAS-ELISA or IC-qRT-PCR for SbDV infection. Numbers of SbDV-positive plants over the total number of plants tested are indicated.

^b Mixtures of *A. tumefaciens* harboring TBSV P19 and full-length cDNA clones of isolates CIIL2 or W4 of SbDV were infiltrated into the abaxial leaf epidermis of leaves with 1-ml needleless syringes at the stage indicated.

^c Not determined.

Table 3.2. Petiole, stem, and vein injection of *Agrobacterium tumefaciens* transformed with *Soybean dwarf virus* (SbDV) cDNA clones.

Plant	Stage	Numbers of infected plants ^a	
		CIIL2 ^b	W4
Soybean ^c	Unifoliate	0/126	0/117
<i>Nicotiana benthamiana</i>	4-5 weeks	6/35	0/42
Red clover	4-5 weeks	8/19	0/10
Fava bean	1-2 weeks	3/5	0/15
‘Puget’ pea	1-2 weeks	7/34	0/17

^a Systemic leaves were tested by DAS-ELISA four weeks after agroinjection. Numbers of SbDV-positive plants over the total number of plants tested are indicated.

^b Mixtures of *A. tumefaciens* harboring TBSV P19 and full-length cDNA clones of SbDV isolates, CIIL2 or W4, were injected into the petioles, stems and veins with 1-ml syringes at the growth stages indicated.

^c Five soybean cultivars were used for agroinoculation: Itachi, Jack, Koganejiri, Shiotsurunoko and Wayne.

Table 3.3. Nodal injection of *Agrobacterium rhizogenes* transformed with *Soybean dwarf virus* (SbDV) cDNA clones.

Plant ^b	Stage	Number of infected plants ^a	
		CiIL2 ^c	W4
Soybean	Unifoliolate	0/23	0/184
Black-eyed pea	Unifoliolate	ND ^d	0/10

^a Systemic leaves were tested either by DAS-ELISA or IC-qRT-PCR for SbDV infection. Numbers of SbDV-positive plants over the total number of plants tested are indicated.

^b Cultivars of soybean used for agroinoculation were Koganejiri, Shirotsurunoko, Wayne, Williams and Yuzuru.

^c Mixtures of *A. rhizogenes* harboring TBSV P19 and full-length cDNA clones of SbDV isolates CiIL2 or W4 were injected around the first node (Estrada-Navarrete *et al.*, 2006).

^d Not determined.

Table 3.4. Vacuum infiltration of *Agrobacterium tumefaciens* transformed with *Soybean dwarf virus* (SbDV) cDNA clones.

Plant	Stage	Number of infected plants ^a			
		CiIL2 ^b		W4	
		Local	Systemic	Local	Systemic
Soybean Koganejiri	Unifoliolate	0/9	0/9	0/10	0/6
Mumford	Unifoliolate	0/4	0/4	ND ^c	ND
<i>Nicotiana benthamiana</i>	4-5 weeks	ND	ND	0/5	0/6

^a Infiltrated (local) and systemic leaves were tested at one and four weeks after inoculation by DAS-ELISA for SbDV infection. Numbers of SbDV-positive plants over the total number of plants tested are indicated.

^b Mixtures of *A. tumefaciens* harboring TBSV P19 and full-length cDNA clones of SbDV isolates CiIL2 or W4 were resuspended in 5% sucrose and 0.01% Silwet-L77 in infiltration buffer and infiltrated as described by Clough and Bent (1998).

^c Not determined.

Table 3.5. Effects on *Soybean dwarf virus* (SbDV) infection of soil drenching of *Agrobacterium tumefaciens* and *Agrobacterium rhizogenes* harboring SbDV cDNA clones.

Plant	Stage	Number of infected plants ^a			
		<i>A. tumefaciens</i> ^b		<i>A. rhizogenes</i>	
		CIIL2	W4	CIIL2	W4
Soybean	Unifoliolate	0/6	0/4	ND ^c	ND
<i>Nicotiana benthamiana</i>	4-5 weeks	0/10	0/5	ND	0/8

^a Newly emerging leaves were tested by DAS-ELISA for SbDV infection. Numbers of SbDV-positive plants over the total number of plants tested are indicated.

^b Mixtures (3 - 5 ml) of *A. tumefaciens* or *A. rhizogenes* harboring TBSV P19 and full-length cDNA clones of SbDV isolates CIIL2 or W4 were drenched on the soil and around the basal parts of stems, which had been pricked with hypodermic needles (Ryu *et al.*, 2004).

^c Not determined.

Table 3.6. Effects on *Soybean dwarf virus* (SbDV) infection of overnight soaking of sprouted seeds with *Agrobacterium tumefaciens* and *Agrobacterium rhizogenes* harboring SbDV cDNA clones.

Plant	Stage	Number of infected plants ^a			
		<i>A. tumefaciens</i> ^b		<i>A. rhizogenes</i>	
		CIIL2	W4	CIIL2	W4
Soybean ^c	Unifoliolate	0/15	0/28	0/10	0/11
Black-eyed pea	Unifoliolate	0/5	0/1	ND ^d	ND

^a Newly emerged leaves were tested for SbDV infection two weeks after inoculation by DAS-ELISA. Numbers of SbDV-positive plants over the total number of plants tested are indicated.

^b Hypocotyls of germinated seeds were pricked with needles and immersed overnight in suspension of *Agrobacterium* harboring TBSV P19 and full-length cDNA clones of SbDV isolates CIIL2 or W4 and planted in soil.

^c Soybean cultivars used were Koganejuro, Shiroturunoko, Wayne, Williams and Yuzuru.

^d Not determined.

Table 3.7. Aphid transmission of *Soybean dwarf virus* (SbDV) by membrane feeding of virus purified from tissues agroinfiltrated with SbDV cDNA clones.

Plant	Stage	Number of infected plants ^a			
		<i>Nearctaphis bakeri</i> ^b		<i>Aphis glycines</i>	
		CIIL2	W4	CIIL2	W4
Soybean ^b	Unifoliolate	0/11	0/24	0/18	0/18

^a Systemic leaves were tested at four weeks after inoculation by DAS-ELISA for SbDV infection. Numbers of SbDV-positive plants over the total number of plants tested are indicated.

^b Virions purified from *N. benthamiana* leaves infiltrated with *A. tumefaciens* harboring full-length cDNA clones of SbDV isolates CIIL2 or W4 were applied between two stretched Parafilm membranes and nonviruliferous *N. bakeri* and *A. glycines* were allowed to acquire the virus for 24 (*A. glycines*) to 48 (*N. bakeri*) hr. Thirty aphids were transferred to each one-week-old unifoliolate soybean seedling, caged and killed after 48 hr of inoculation access.

^c Soybean cultivars used were Koganejiri, Mumford, Shiroturunoko and Wayne.

Table 3.8. Aphid transmission of *Soybean dwarf virus* (SbDV) from plants systemically infected by agroinjection with a cDNA clone of the CIIL2 isolate.

Source plant	Aphid ^a	Inoculated on	No. of plants infected ^b
<i>Nicotiana benthamiana</i>	<i>Myzus persicae</i>	Unifoliolate Wayne	0/7
<i>Nicotiana benthamiana</i>	<i>Aphis glycines</i> ^c	Unifoliolate Wayne	0/3
'Puget' pea	<i>Nearctaphis bakeri</i>	Unifoliolate Wayne	0/3
'Puget' pea	<i>Nearctaphis bakeri</i>	Unifoliolate Mumford	0/7
Fava bean	<i>Nearctaphis bakeri</i>	Unifoliolate Mumford	0/7
Red clover	<i>Nearctaphis bakeri</i>	Unifoliolate Wayne	0/3

^a Aphids were given an acquisition access of 24 hr and 30 aphids were transferred to each soybean plant. Aphids were given an inoculation access as long as they lived on the plants.

^b Plants were tested by DAS-ELISA after a month of SbDV infection. Numbers of SbDV-positive plants over the total number of plants tested are indicated.

^c *A. glycines* was given acquisition access of 30 min due to death on *N. benthamiana*.

Table 3.9. Differences in amino sequences of readthrough proteins of red clover (CIIL2) and soybean (W4) isolates of *Soybean dwarf virus*.

Isolate	Amino acid positions in the readthrough domain																
	255	272	457	462	466	470	472	473	474	475	503	514	533	575	607	630	639
CIIL2	S	T	T	E	M	F	E	E	D	N	T	T	T	A	E	V	K
W4	P	A	P	I	T	D	D	G	Y	S	C	I	M	T	G	A	N

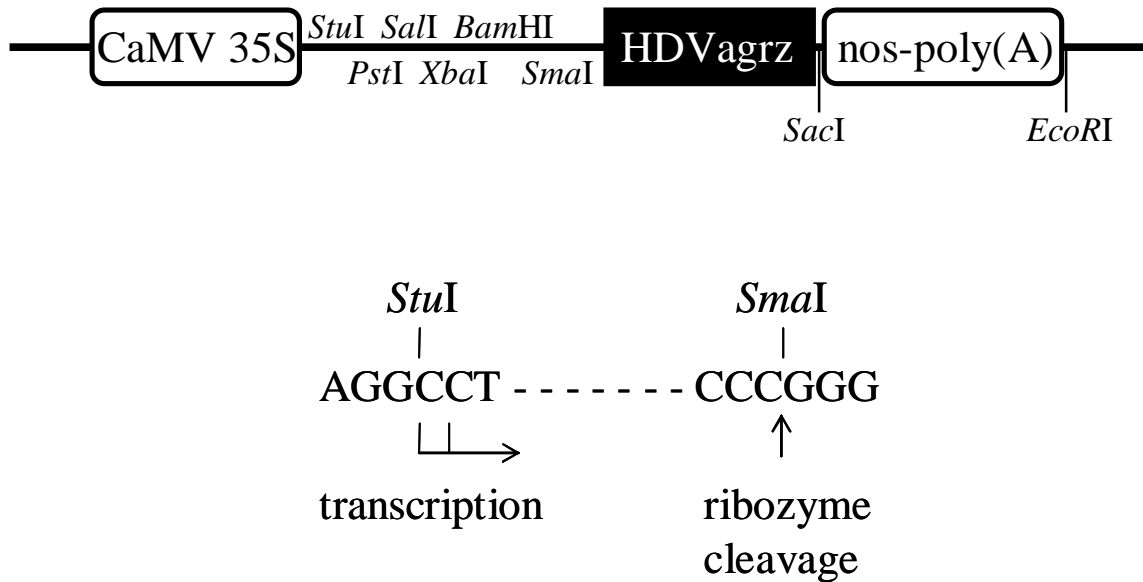
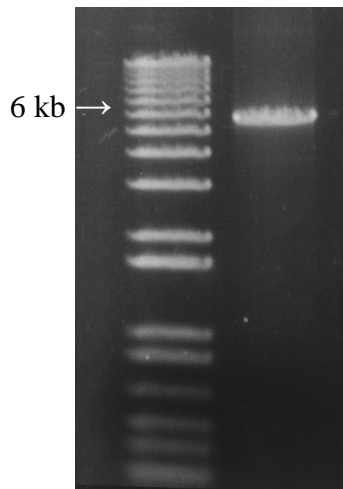

Figure 3.1. The cDNA cloning site derived from the plasmid pHST40 (Scholthof *et al.*, 1992). Transcriptional start sites and the *Hepatitis delta virus* antigenomic ribozyme (HDVagrz) RNA cleavage site are indicated. *Soybean dwarf virus* cDNA was cloned downstream of the *Cauliflower mosaic virus* (CaMV) 35S promoter between the *StuI* and *SmaI/XmaI* sites.

**SbDV full-length
RT-PCR product**



Ligated pCAMBIA and SbDV

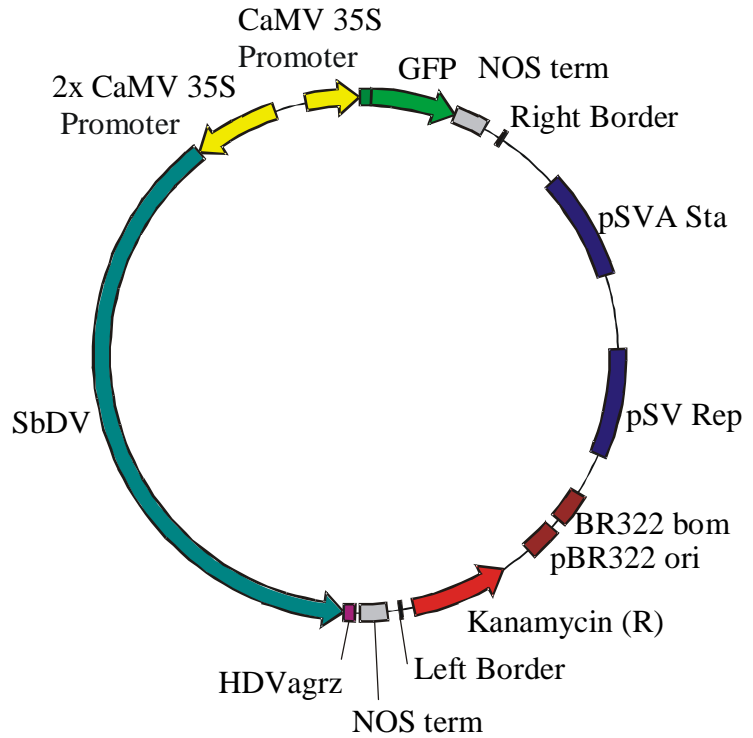

Figure 3.2. Synthesis and cloning of full-length copies of *Soybean dwarf virus* (SbDV) genomic RNAs. Full-length copies of SbDV genomic RNAs were synthesized by reverse-transcription polymerase chain reaction (RT-PCR) using high-fidelity DNA polymerases. The products were cleaved with *StuI* and *XmaI* and ligated into pCZ14 between a doubled *Cauliflower mosaic virus* (CaMV) 35S promoter and *Hepatitis delta virus* antigenomic ribozyme (HDVagrz).

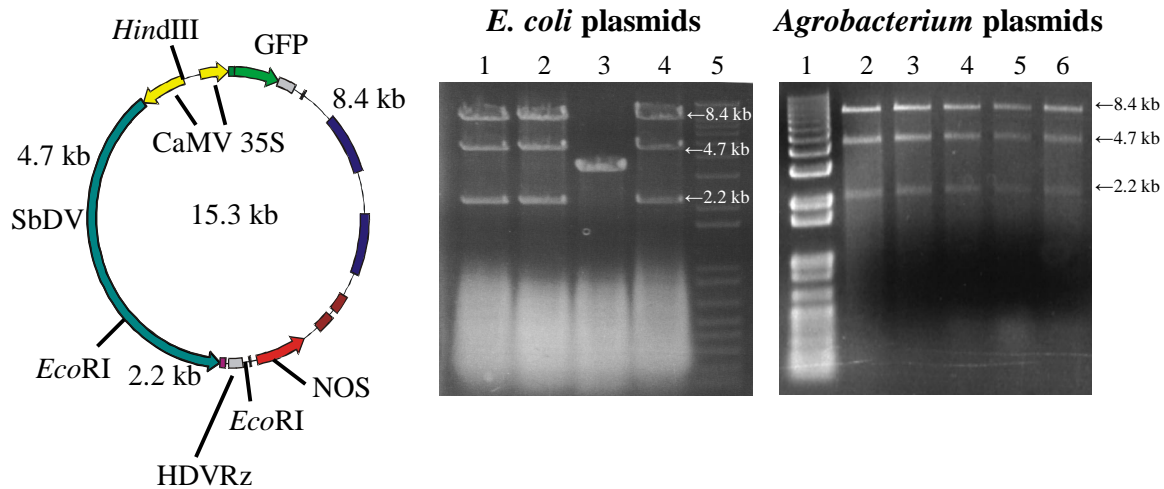

Figure 3.3. Confirmation of the presence of intact full-length clones of *Soybean dwarf virus* (SbDV) in *Escherichia coli* and *Agrobacterium tumefaciens*. Plasmids containing full-length copies of SbDV genomic RNA were isolated from *E. coli* and used to transform *A. tumefaciens* strain KYRT1. Plasmid DNAs were isolated from four *E. coli* colonies (Lanes 1-4) and five *A. tumefaciens* (Lanes 2-6), digested with *EcoRI* and *HindIII*, and analyzed on 1.0% agarose gels. The digestion patterns produced by plasmids isolated from the two bacteria were identical indicating that no rearrangements had occurred after transformation of *Agrobacterium*.

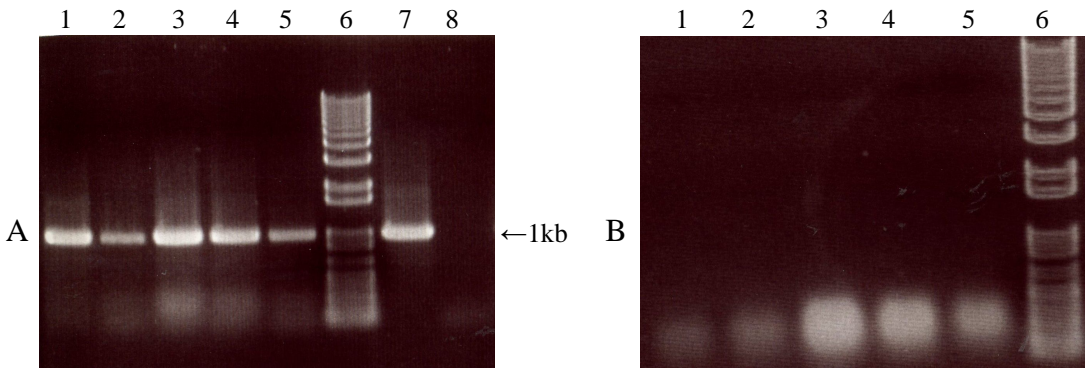

Figure 3.4. Reverse transcription polymerase chain reaction (RT-PCR) products from systemic leaves of *Nicotiana benthamiana* plants agroinjected with full-length clones of *Soybean dwarf virus* isolate CIIL2. Total RNA was extracted from systemic leaves of DAS-ELISA-positive plants and RT-PCR was carried out with (A) and without (B) reverse transcription. (A) With reverse transcription, all DAS-ELISA-positive samples (lanes 1-5) showed 1-kb PCR products. Lanes 7 and 8: Positive and negative controls for PCR, respectively. (B) Without reverse transcription, none of the DAS-ELISA-positive samples (lanes 1-5) showed 1-kb PCR products. Lane 6: 1-kb plus DNA ladder.

CHAPTER 4

STRAIN-SPECIFIC PACKAGING OF *SOYBEAN DWARF VIRUS* SMALL SUBGENOMIC RNA

ABSTRACT

Encapsidation of viral RNAs by structural proteins is a highly specific process and it is an essential step in the life cycle of most RNA viruses. The RNAs packaged by a soybean (Wisc4 [W4]) and two red clover (ClAgt2 and ClIL2) isolates of *Soybean dwarf virus* (SbDV) were analyzed. Virions purified from ClAgt2-infected soybean and W4 and ClIL2 infected *Nicotiana benthamiana* tissues were fractionated on 10-40% sucrose density gradients. Double-antibody sandwich enzyme-linked immunosorbent assay (DAS-ELISA) using a monoclonal antibody to SbDV detected single peaks of virions in density gradients. RNA was extracted from each fraction, separated on agarose gels, blotted to nylon membranes and hybridized with a 3'-proximal biotinylated probe. The red clover isolates ClIL2 and ClAgt2 encapsidated both genomic RNA (gRNA) and small subgenomic RNA (SsgRNA) while, the soybean SbDV isolate, W4, packaged only gRNA. Rapid amplification of cDNA end analysis showed that encapsidated small RNA corresponded to SsgRNA. The large subgenomic RNA was not packaged into virions as indicated by its presence primarily in ELISA-negative fractions near the tops of sucrose gradients. No crosslinking of packaged RNAs were observed during heat and UV-treatments of virions. In this study packaging of SbDV SsgRNA was isolate specific. The differential packaging of SsgRNA suggested that a packaging signal is located near the 3' end of the genomic RNA within the SsgRNA that is distinct from the signal recognized for packaging of SbDV gRNA.

INTRODUCTION

Genome packaging by structural proteins is an important step in the life cycle of most RNA viruses. Packaging is a highly specific process in which viral RNAs are distinguished from other

cellular RNAs for assembly into virus particles. In addition, the genomic RNA of one virus is not usually packaged by coat proteins (CPs) of an unrelated virus, which suggests that viral CPs can distinguish between different viral RNAs for selective packaging. Such specificity is attributed to the recognition of sequences or structures unique to viral genomes called origin of assembly sequences (OAS) or packaging signals (Rao, 2006). The major factors influencing packaging are packaging signals, structure of RNA and physical size of the virion (Rao, 2006).

Few studies have been conducted on the encapsidation of single-stranded plant RNA viruses and packaging signals have been identified only in *Brome mosaic virus* (BMV; Choi and Rao, 2003; Damayanti *et al.*, 2003), *Southern bean mosaic virus* (SbMV; Hacker, 1995), *Turnip crinkle virus* (TCV; Qu and Morris, 1997), *Tobacco mosaic virus* (TMV; Zimmern, 1977), and *Turnip yellow mosaic virus* (TYMV; Bink *et al.*, 2003).

Studies on encapsidated RNA content of other luteovirids revealed packaging of only genomic (g) RNA in *Barley yellow dwarf virus* (BYDV; Mohan *et al.*, 1995), *Beet western yellows virus* (BWYV; Reutenauer *et al.*, 1993) and *Cucurbit aphid-borne yellows virus* (CABYV; Pruffer *et al.*, 1995) and gRNA and subgenomic RNA (sgRNA) in *Potato leafroll virus* (PLRV; Lee *et al.*, 2005). No detailed studies have been conducted in luteovirids that suggested the position or nature of packaging signals.

Soybean dwarf virus (SbDV) transcribes two sgRNAs from minus-strand RNAs. The 2990 nucleotide (nt) long large sgRNA (LsgRNA) encodes the movement protein and the structural proteins, (CP and readthrough protein [RTP]), while the role of a 220 nt small sgRNA (SsgRNA) is unknown. Presence of abundant amounts of SsgRNA along with gRNA and LsgRNA during early stages of infection suggested it may have a regulatory role in SbDV infection (Yamagishi *et al.*, 2003). Currently no information is available on the selective packaging of these RNAs in SbDV virions. Hence, this study was conducted to analyze the packaged RNA content of SbDV virions.

MATERIALS AND METHODS

Virus isolates

The analysis of packaged RNA content of SbDV was conducted on three different dwarfing isolates; two clover isolates (CIAgt2 and CIIL2) and one soybean isolate (Wisc4 [W4]). Full-length cDNAs of both W4 and CIIL2 were cloned into a binary vector, transformed into *Agrobacterium tumefaciens*, and infiltrated into *Nicotiana benthamiana* leaves. The construction of infectious full-length clones of these isolates and their introduction into *N. benthamiana* through agroinfiltration were described in Chapter 3. Full-length cDNA clones of the CIAgt2 isolate were also constructed, but the clones were not infectious. Consequently, the CIAgt2 isolate was maintained in red clover and transmitted to soybean by inoculation with either soybean (*Aphis glycines*) or clover (*Nearctaphis bakeri*) aphids.

Virus purification and encapsidation assays on SbDV isolates

Sucrose gradient centrifugation

Virus was extracted from 100 g tissue by homogenizing in 0.1 M sodium phosphate buffer (pH 7.0) and 0.1% sodium sulfite. Four volumes of chloroform-butanol (1:1) were added and mixed in a chilled blender five times each for one min. This mixture was then filtered through cheese cloth, and PEG 6000 and NaCl were added to final concentrations of 10% and 0.25 M, respectively. Subsequently, the samples were stirred for 15 min at room temperature, incubated in ice for 1 hr, and centrifuged at 7,500 rpm in a Sorvall GS3 rotor for 20 min at 4°C. Pellets were resuspended in sodium phosphate buffer.

The resuspended virions were centrifuged at 10,000 rpm for 10 min at 4°C in a Sorvall GS6 rotor. Supernatants were applied on top of 20% sucrose pads made with 0.1 M sodium phosphate buffer, and centrifuged at 45,000 rpm for 2 hr in a Beckman 50.2 Ti rotor. Pellets were resuspended in 0.5 ml phosphate buffer, layered on top of 10-40% sucrose gradients, and centrifuged at 35,000 rpm for 4 hr. Gradients were prepared by freeze thawing (twice) 25% sucrose solution in 0.1 M sodium phosphate buffer (pH 7.0) (Davis and Pearson, 1978). Fifteen

fractions of 500-600 µl were collected from the bottom of each gradient using a peristaltic pump. Virion RNAs were extracted from sucrose gradient fractions using the RNeasy Plant Mini Kit (Qiagen Inc. Valencia, CA) by adding 1.2 ml of RLT buffer to each gradient fraction and following the rest of the manufacturer's instructions.

Double-antibody sandwich enzyme-linked immunosorbent assay (DAS-ELISA) on sucrose gradient fractions

To identify fractions containing virions, 50 µl of each gradient fraction was diluted with an equal volume of Agdia General Extraction Buffer (GEB) and analyzed by DAS-ELISA according to Agdia protocols (Elkhart, IN). A solution of 25% sucrose in 50% GEB was used as a negative control. All samples were duplicated.

Northern blot

Preparation of biotinylated probes

A 219-bp amplified product from cDNA was synthesized by PCR using primer pair 5301F (5'-CCTCTCTTGT AAACCACATA-3') and 5520R (5'-ACGCTTTCATTTAACGCCAT-3'), *Taq* DNA polymerase and biotinylated dCTP (Invitrogen, Carlsbad, CA) with 35 cycles of thermocycler program: 94°C for 30 s, 48°C for 30 s and 72°C for 15 s. Depending on the size of the blot, 3-5 µl of the probe was used for each blot.

Northern blot

RNAs were denatured at 100°C for 5 min in RNA loading buffer (containing 95% formamide, Ambion, Austin, TX) and separated by electrophoresis in 1% agarose gels in TBE (Sambrook and Russell, 2001). After electrophoresis at 100 V for 50 min, RNA gels were denatured in 50 mM NaOH in diethyl pyrocarbonate (DEPC)-treated water twice for 15 min each at room temperature with gentle shaking, and neutralized by soaking in transfer buffer (0.5×TBE in DEPC-treated water) three times at room temperature for 10 min each. Unused portions of the

gels were trimmed to reduce the size. RNAs were transferred electrophoretically using Trans-Blot SD RNA Blotting kit (Bio-RAD, Hercules, CA) onto Amersham Hybond-N⁺ (GE healthcare Ltd, UK) positively charged nylon membrane. The membranes were oven dried at 80°C for 15 min and UV-crosslinked on both sides (1200 µJ, Strata linker, Stratagene, Lajola, CA).

Transfer membranes were pre-hybridized with ULTRArrayTM hybridization buffer (Ambion Inc.) for one hr at 42°C and hybridized with the SbDV probe overnight. Hybridized membranes were washed twice at 42°C for 30 min each with 2×SSC (300 mM NaCl, 30 mM NaCitrate, pH 7.0), 0.5% SDS followed by three washings in blocking buffer (0.2% I block, 1×TBS (50 mM Tris-HCl, pH 7.4, 150 mM NaCl) and 0.5% SDS) for 5 min each. Membranes were soaked in 1:5000 dilution of Avidx alkaline phosphatase enzyme in blocking buffer for 30 min at room temperature. Subsequently, membranes were washed three times (5 min each) in 1×TBS and 0.5% SDS followed by two washings (2 min each) in assay buffer (1 mM MgCl₂, 1 M diethanolamine, pH 9.8) and a final washing in CDP star (New England BioLab, Ipswich, MA) for 5 min. Membranes were then exposed to photographic films for 5 hr or overnight.

RNase sensitivity assay on virion-derived RNAs

Ten grams of frozen soybean tissue infected with CIAGt2 isolate was homogenized in 20 ml 0.1 M sodium phosphate buffer (pH 7.0) and 0.1% sodium sulfite, and centrifuged at 10,000 rpm for 15 min to pellet plant debris. The supernatant was filtered through cheese cloth and virions were precipitated by the addition of 0.25 volumes of 40% polyethylene glycol (average mol. wt. 6000, PEG 6000) in 1 M NaCl followed by incubation on ice for 30 min. The sample was then centrifuged at 10,000 rpm for 15 min and the pelleted virions were resuspended in 3 ml 100 mM sodium phosphate buffer (pH 7.0). This was then subjected to high speed centrifugation at 45,000 rpm for 1 hr and pelleted virions were resuspended in 100 µl 0.1 M sodium phosphate buffer.

To avoid detecting any unencapsidated viral RNAs, the partially purified virions were treated with chloroform to disrupt membranous structures to release entrapped viral RNAs, and digested

with RNase A (Cho and Dreher, 2006). To the resuspended virions, 0.2 volumes of chloroform was added and centrifuged at 14,000 rpm for a min and the upper clear aqueous phase was collected. Samples were digested with RNase A at a final concentration of 5 µg/ml (Cho and Dreher, 2006) for 30 min at 37°C followed by treatment with proteinase K at a final concentration of 100 µg/ml for 30 min at 37°C to inactivate RNase A.

From the RNase treated virions, RNAs were extracted using Qiagen RNeasy Plant Mini Kit (Qiagen) according to the manufacturer's instruction. RNAs were subjected to northern blot as described above. To verify the northern blot result, the virus purification was repeated as described and virions were subjected to further purification by high-speed centrifugation (70,000 rpm for 1 hr) through 20% sucrose pad in Beckman 70.1 Ti rotor. The recovered virions were extracted with chloroform, digested with RNase A and proteinase K, and northern blots were repeated on extracted virion-derived RNA.

The strandedness of encapsidated SbDV RNAs was tested by digestion with RNase A. Virion RNAs extracted from 2.5 g CIAgt2-infected soybean tissue were treated with RNase A in either 0.1×SSC or 2×SSC followed by proteinase K digestion as described earlier. Viral RNAs in 2×SSC without further treatment were used as controls. Samples were subjected to northern blot analysis and experiments were repeated twice.

RNA-crosslinking analyses

To determine whether gRNA and SsgRNA were present in the same particles and would crosslink to each other, partially purified virions were treated with UV light and heat as described by Basnayake *et al.* (2006). Multimer formation of RNAs during heat treatment and UV-crosslinking were used to demonstrate packaging of viral RNAs in the same virion in icosahedral viruses like *Flock house virus* and *Red clover necrotic mosaic virus* (RCNMV) (Krishna and Schneeman, 1999; Basnayake *et al.*, 2006). The formation of RNA complex occurs when the RNAs are in close proximity. In UV-crosslinking, high molecular weight RNAs can be formed either through transient interactions or base pairing (Juzumiene *et al.*, 2001; Whirl-Carrillo *et al.*, 2002).

Heat treatment of virions

Seven equal fractions of purified virus, extracted from 5 g of CIAGt2 infected soybean tissue were subjected to heat treatments of 25°C, 40°C, 50°C, 60°C, 70°C, 80°C and 90°C for 10 min. Samples were immediately cooled in ice and RNAs were extracted for northern-blot analysis.

UV-treatment of virions

For UV-treatment of virions, virus was extracted from 5 g of CIAGt2 infected soybean tissue. Half of each sample was exposed to UV radiation (312 nm, Foto/UV 300 Ultraviolet Transilluminator, Fotodyne Inc., Hartland, WI) for 20 min. The other half was kept as a UV-free control. Both samples were digested with proteinase K at a final concentration of 100 µg/ml for 30 min at 37°C to remove any proteins bound to RNAs. Virion RNAs were analyzed on northern blots.

RNA ligase-mediated rapid amplification of cDNA ends (RLM-RACE) and sequencing of encapsidated small RNAs

To confirm the small RNA packaged in CIIL2 virions was the 220 nt SsgRNA of SbDV, sequencing reactions were performed on 5' and 3' RACE products obtained from virion-derived small RNAs. SbDV was purified from 50 g of CIIL2 agroinfiltrated *N. benthamiana* tissue by sucrose gradient centrifugation as described earlier. The gradient fraction with the virus peak was identified by DAS-ELISA and RNAs were extracted. The 3' end of the viral RNA (about 1 µg) was polyadenylated by poly (A) polymerase (Ambion Inc.) and the reaction was terminated by heat inactivating the enzyme at 70°C for 8 min. The 5' RNA adapter was ligated to the 5' end of the polyadenylated RNA according to the manufacturer's protocol (Ambion Inc.) and 2 µl (180 ng) of this RNA was reverse transcribed using a 3' oligo(dT) primer provided with the kit.

Two separate polymerase chain reactions (PCRs) were conducted to obtain 5'-RACE and 3'-RACE products. The 5' RACE was conducted using the 5'-RACE outer primer and SbDV 5688R (5'-CACCTTAACAACAAAGAGGC-3'), while 3' RACE was performed using the 3'-

RACE outer primer and SbDV 5501F (5'-ATGGCGTTAAATGAAAGCGT-3'). For both reactions, the RACE cDNA was amplified with *GoTaq* polymerase using 35 cycles of denaturation at 94°C for 30 s, annealing at 50°C for 30 s and extension at 72°C for 30 s.

The two PCR products were purified and cloned into pCR 2.1-TOPO (Invitrogen) and electroporated into *Escherichia coli* cells. Plasmids extracted from transformed *E. coli* colonies were digested with *EcoRI-HindIII* pair to confirm the presence of inserts and sequenced with M13 forward primer (Invitrogen). The sequences obtained from 5'-RACE and 3'-RACE PCR products were overlapped to get the entire sequences of the small RNA encapsidated in SbDV virions. Sequences were aligned with the CIIL2 sequence and identified the starting and ending positions for the small RNA.

Nucleotide sequence analysis of SbDV isolates

Since differential encapsidation of SsgRNA was observed in the present study, all three isolates of SbDV were analyzed for any significant sequence difference in the 3' end of the viral genome (CP, readthrough protein (RTP) and 3' untranslated region (UTR)). Both strands of the plasmids of each of these isolates were sequenced using forward and reverse primers in 10 sequencing reactions. Eight of these primers were described in Table 2.2. Two additional primers were used: 5301F (5'-CCTCTCTTGT AAACCACATA-3') and Pcam8877F (5'-CTGGGAACTACTCACACATTATTATGGAGA-3'). Sequences were edited, assembled, translated (for CP and RTP), and aligned as described in Chapter 2. The predicted structure of SsgRNA of all three isolates was derived using pknotsRG software (Reeder *et al.*, 2007) and analyzed for folding differences and possible secondary structures.

RESULTS

Encapsidation assays on SbDV isolates

Virion-derived RNAs were analyzed from three SbDV isolates (CI1Agt2, CIIL2 and W4) by DAS-ELISA and northern blot analysis of sucrose gradient-purified virions. Sucrose gradients of

virions prepared from SbDV-infected soybean (ClAgt2) and *N. benthamiana* (CIIL2 and W4) contained single ELISA-positive peaks that corresponded to the sedimentation of intact virions. Northern blot analysis of RNAs extracted from ELISA-positive sucrose gradients fractions of ClAgt2 and CIIL2 detected gRNA and SsgRNA (Figures 4.1 and 4.2; lane 1), but only gRNA of the W4 isolate (Figure 4.2; lane 2). In purified virion of isolates ClAgt2 and CIIL2, the signal from the SsgRNA was much stronger than that of gRNA even though gRNA is almost approximately 25 times larger than SsgRNA (Figures 4.1 and 4.2; lane 1). These results suggest that SsgRNA of isolates ClAgt2 and CIIL2 was preferentially encapsidated in comparison to gRNA. To confirm that the small RNA packaged was SsgRNA and not a defective interfering (DI) RNA or degraded viral RNAs, the CIIL2 blot was also hybridized with another biotinylated probe made from the 5' end of the genome (region corresponding to 1217 - 1419). The probe detected only gRNA (Figure 4.2; lane 5). The results indicated that the small RNAs associated with SbDV virus particles were derived primarily from the 3' UTR.

With all three SbDV isolates, LsgRNA was detected primarily at the tops of gradients in DAS-ELISA-negative fractions (Figures 4.1A and 4.2; lanes 3 and 4). To verify that SbDV RNAs in DAS-ELISA-positive fractions were protected by SbDV structural proteins (CP and RTP), a mutant of the W4 isolate was created in which ORF3, which encodes CP, was deleted (construction of this mutant is described in Chapter 5). As expected, sucrose gradient fractions of extracts prepared from *N. benthamiana* tissues infiltrated with the ORF3 deletion mutant did not contain a DAS-ELISA-positive peak (data not shown). Neither gRNA nor SsgRNA were detected by northern blot analysis of RNA extracted from sucrose gradient fractions that corresponded to the sedimentation of SbDV virion (Figure 4.1C). A LsgRNA that was smaller than wild-type was detected near the top of the sucrose gradients. The smaller size of the LsgRNA resulted from the deletion of ORF3 in this mutant. These results confirmed the SbDV CP was not associated with LsgRNA.

To determine whether the virus associated RNAs were protected by proteins and single-stranded, partially purified virions (prior to sucrose gradient centrifugation) from soybean plants systemically infected with the ClAgt2 isolate of SbDV were treated with RNase A before and after deproteinization and analyzed on northern blots. Prior to deproteinization, all three RNAs,

gRNA, LsgRNA and SsgRNA, survived RNase A treatment (Figure 4.3A). After deproteinization, all three RNAs were degraded by RNase A treatment in low (0.1×SSC) and high (2×SSC) salt (Figure 4.3B). These results suggest that all three RNAs are associated with proteins that protected them from degradation by RNase A and that all three RNAs are single stranded.

RNA crosslinking analyses

RNA crosslinking analyses were performed on partially purified CIAGT2 virions to determine whether gRNA and SsgRNA were present in the same virus particles. During heat treatment of virions, gRNA and SsgRNA disappeared between 50°C and 60°C (Figure 4.4A) and a new band smaller than LsgRNA and larger than SsgRNA appeared at 60°C (Lane 4). The LsgRNA was observed even at 90°C. The UV-exposure of partially purified virus degraded both gRNA and SsgRNA, but preferentially degraded SsgRNA and no multimer formation was observed (Figure 4.4B).

RLM-RACE sequencing of encapsidated small RNAs

The nucleotide sequences of 12 5'-RACE and three 3'-RACE clones were analyzed and compared to the sequence of SbDV genomic RNA. All three 3'RACE clones were co-terminal with the gRNA and ended exactly at nt position 5709. The 5' RACE clones had different start sites for the SsgRNA (Figure 4.5). Out of the 12 clones sequenced, five clones started at or near position 5490, which is predicted to be the start site for SbDV SsgRNA (Yamagishi *et al.*, 2003). A second group of clones was shorter compared to that of the first group, and started at positions 5533 - 5543. One RNA was 23 nt longer than the predicted size of 220 nt and started at position at 5468. Among these RNAs, all but one had a common 'CCCCT' sequence at or near their 5' termini.

Three single nt substitutions and two insertions were observed in some of these RNAs compared to the wild-type CIIL2 isolate. Three of clones had G to A substitutions at position 5567 and A to G substitutions at positions 5603 and 5666. In addition to these, insertions of T between

positions 5649 and 5650 and C between positions 5679 and 5680 were observed. These changes did not affect their encapsidation into SbDV particles.

Nucleotide sequence analysis of SbDV isolates

The 3' UTRs of isolates ClAgt2 and CiIL2, which encapsidate SsgRNA, were analyzed for common nt that differentiated them from the W4 isolate. Similarly, CP and RTP regions were analyzed for differences in their amino acid sequences. In the 3' UTR, nine nt changes were observed (Table 4.1). Among these, four were located in the predicted SsgRNA region (nt position 5490-5709). In addition to these changes, insertion of seven As were observed in the W4 isolate in between positions 5200 and 5201. The stem-loop structures observed in the SsgRNA of SbDV isolates were similar (Figure 4.6). No amino acid changes were observed in CP while, 17 amino acid substitutions were observed in the RTD of RTP in the W4 isolate compared to CiIL2 and ClAgt2 isolates (Table 4.2).

DISCUSSION

The current study suggests that packaging of SbDV SsgRNA is isolate specific. Red clover isolates ClAgt2 and CiIL2 encapsidated both gRNA and SsgRNA, while the soybean isolate, W4, packaged only gRNA (Figure 4.1 and 4.2). The W4 isolate did not encapsidate SsgRNA, replicated to much lower levels than ClAgt2 and CiIL2, and failed to move systemically in *N. benthamiana*. Packaging of SsgRNAs was observed in both soybean and *N. benthamiana*, and hence was not host specific. Detection of only gRNA in northern blots with a 5' probe and the finding that small packaged RNAs are 3' co-terminal with the gRNA support the conclusion that the small RNAs are not DI RNAs or degraded RNAs, but rather represent SsgRNA of SbDV. Efficient encapsidation of sgRNAs were reported in other plant RNA viruses that belongs to alphavirus superfamily. For example, *Alfalfa mosaic virus* (AMV; Brederode *et al.*, 1980), BMV (Ahlquist *et al.*, 1981), *Cucumber mosaic virus* (CMV; Gould and Symons, 1982) and TYMV (Guilley and Briand, 1978), all package the sgRNA needed for CP synthesis and genome activation.

The differential encapsidation of SsgRNA exhibited by SbDV isolates could be due to sequence differences in the structural proteins, particularly in the RTD (amino acid sequences), and/or the SsgRNA (nucleotide sequences) (Tables 4.1 and 4.2). Encapsidation requires specific recognition of viral RNAs by structural proteins. Protein-protein interaction and sequence-dependent and sequence-independent protein-RNA and RNA-RNA interactions play crucial roles in precise assembly and packaging of viral genomes (Rao, 2006). The amino acid substitutions observed in the RTP of W4 isolate compared to CIIL2 and CIAgt2 isolates could influence the interaction of structural proteins with SsgRNA for its encapsidation. The nt changes and insertions observed in W4 could have an effect on RNA structure and *cis*-interactions needed for the encapsidation. Differential encapsidation of sgRNAs between two isolates of *Bamboo mosaic virus*, a potexvirus, also was reported by Lee *et al.* (1998).

The LsgRNA was primarily observed in DAS-ELISA-negative fractions from near the top of sucrose gradients, which indicated that it was not assembled into virus particles. However, LsgRNA survived treatment of partially purified virions with RNase A. None of the viral RNAs survived RNase A treatment after deproteinization, suggesting that the RNAs were protected by proteins and were single stranded. Lee *et al.* (2005) also found that sgRNA of PLRV, another luteovirid, was stable after RNase digestion, but they did not purify virus particles using sucrose gradients. The sgRNA observed in their study likely corresponds to the low-density LsgRNA observed in this study that was detected near the tops of sucrose gradients. The disappearance of gRNA and SsgRNA during treatment at 60°C suggested that virions became unstable at 60°C due to the denaturation of CPs resulting in the degradation of the exposed virion RNAs. The LsgRNA was stable even at 90°C. A new RNA band formed at 60°C, which likely represented multimers of SsgRNA. The LsgRNA was also detected in sucrose gradients of the CP-deletion mutant. Because of the ORF3 deletion, this particular clone would not produce CP, RTP or movement protein. In UV-crosslinking experiments (Figure 4.4B), LsgRNA was still present in the UV-exposed sample that was also treated with proteinase K. These experiments support the conclusion that LsgRNA is not protected by CP, but may be protected by SbDV replication-related proteins, host proteins or components that can survive very high temperatures and proteinase K digestion.

Even though the LsgRNA has the same 3' end as that of gRNA and SsgRNA, it was not packaged into SbDV particles. Unlike rod shaped viruses, icosahedral viruses have limits on the lengths of RNAs they can encapsidate. Size of the viral RNA being packaged has proved to be a critical factor for stable assembly of virions in TCV (Qu and Morris, 1997). This might be true in the case of other isometric viruses also. Since gRNA and SsgRNA are efficiently packaged, but not LsgRNA, which is half the size of the gRNA and 13 times larger than SsgRNA, size limitations are unlikely to have a role in the lack of encapsidation of SbDV LsgRNA. Since LsgRNA is protected from RNase degradation, it is possible that the RNA is sequestered and not available for packaging. Also, it is possible that the SsgRNA forms different secondary structures than the LsgRNA that are recognized for packaging. Currently, the function(s) of SsgRNA are unknown. Its encapsidation in SbDV particles suggests that it could play an important role early in the viral infection cycle. This hypothesis is supported by the observation of lower titers and lack of systemic movement of the W4 isolate in *N. benthamiana* compared to CIIL2.

The presence of gRNA and SsgRNA in DAS-ELISA-positive sucrose gradient fractions indicated that they were protected by SbDV CP. The absence of these RNAs in the corresponding region of sucrose gradients of the CP-deletion mutant and simultaneous loss of both gRNA and SsgRNA from virus samples treated at 60°C or higher supports this conclusion. It is not clear whether the gRNA and SsgRNA are co-packaged in a single particle or assembled in two different particles. Crosslinking between gRNA and SsgRNA was not observed after UV-treatment of partially purified CIAGt2 virions, which would have been possible if they were in the same particle. Also, the disappearance of SsgRNA, but not gRNA after UV-treatment suggested that these two RNAs could be packaged in two separate virions with different stabilities. Since gRNA and SsgRNA were observed in the same gradient fractions, if these two RNAs are assembled in two separate virions, they must possess nearly equal sedimentation coefficients or S-values. If the size limit for SbDV isometric virions is about the length of gRNA (5709 nt), then particles containing only SsgRNA could encapsidate approximately 25 copies of the 220 nt RNA, which might explain the higher abundance of the SsgRNA in comparison to gRNA in purified virus.

The RACE analysis confirmed that the encapsidated small RNA in CIIL2 isolate is SsgRNA. The 3' termini of SsgRNA clones were the same as gRNA. It is believed that sgRNAs are synthesized by the *de novo* initiation at a *cis*-acting subgenomic promoter in the minus strands by viral polymerase enzymes (Koev and Miller, 2000). Also, a mechanism involving premature termination during minus-strand RNA synthesis followed by replication of the sgRNA has been suggested for RCNMV (Sit *et al.*, 1998). In the present study, RACE sequencing revealed different start sites for the encapsidated SsgRNA (Figure 4.5). It is possible that viral replicase starts the synthesis of this RNA at different positions on minus-strand RNA or terminates the minus-strand RNA synthesis at different nucleotide positions. The varying 5' terminal start sites could also be due to the degradation by 5' nucleases before their assembly into virions.

In TYMV, stem-loop structures in the 5' UTR are involved in packaging where the stability of the loops is affected by environmental conditions (Bink *et al.*, 2003). The stem-loop structures in the SsgRNA region of SbdV isolates could interact differentially with the viral CP for their encapsidation. The predicted structures of SsgRNAs of all three isolates were similar. Among the four nt changes observed in this region, the change from A to G in W4 isolate at position 39 of the SsgRNA (Figure 4.6, position 5528 in genomic RNA) may most likely affect the stability of the proximal stem-loops. The changes observed at 5642 and 5653 were complimentary and suggested that these changes happened to conserve the structure at that region. It is possible that any of these changes observed in the SbdV isolates could be responsible for the differential encapsidation of SsgRNA. Further experiments using site-directed mutagenesis are needed to identify the sequences responsible for differential encapsidation of SbdV SsgRNA.

The differential encapsidation in SbdV isolates suggests that at least two signals are involved in the packaging of SbdV RNAs. Packaging of SsgRNA in CIIL2 and ClAgt2 isolates suggests that the assembly of SsgRNA in SbdV virions requires a packaging signal located within the SsgRNA region at the 3' end of the gRNA and that signal is absent from the W4 isolate. Since W4 encapsidate the gRNA, the packaging signal needed for the assembly of gRNA might be different. For positive-strand RNA viruses, packaging signals have been reported in different parts of the viral genome. In potexviruses, the packaging signal is located at the 5' UTRs (Sit *et al.*, 1994; Lee *et al.*, 1998), while in BMV, a tRNA-like structure located in the 3'UTR was

involved in packaging (Choi *et al.*, 2002). In TCV (Qu and Morris, 1997) and bromoviruses (Vriend *et al.*, 1986; Sacher and Ahlquist, 1989; Fox, 1994; Zhao *et al.*, 1995), the OAS was identified at the 3' and 5' end of CP coding region respectively.

The present investigation showed that some dwarfing isolates of SbDV encapsidate both gRNA and SsgRNA and the encapsidation of SsgRNA is isolate specific but not host specific. To our knowledge this is the first report of encapsidation of a sgRNA in the *Luteovirus* genus. Also, differential packaging of viral RNAs among virus isolates within *Luteoviridae* has not been reported earlier.

REFERENCES

- Ahlquist, P., Luckow, V. and Kaesberg, P. 1981. Complete nucleotide sequence of brome mosaic virus RNA 3. *J. Mol. Biol.* 153:23-38.
- Basnayake, V.R., Sit, T.L. and Lommel, S.A. 2006. The genomic RNA packaging scheme of *Red clover necrotic mosaic virus*. *Virology* 345:532-539.
- Bink, H.H., Schirawski, J., Haenni, A.L. and Pleij, C.W. 2003. The 5' proximal hairpin of turnip yellow mosaic virus RNA: its role in translation and encapsidation. *J. Virol.* 77:7452-7458.
- Brederode, F. T., Koper-Zwarthoff, E. C. and Bol, J. F. 1980. Complete nucleotide sequence of alfalfa mosaic virus RNA 4. *Nucleic Acids Res.* 8:2213-2223.
- Cho, T.J. and Dreher, T.W. 2006. Encapsidation of genomic but not subgenomic turnip yellow mosaic virus RNA by coat protein provided in trans. *Virology* 356:126-135.
- Choi, Y.G. and Rao, A.L.N. 2003. Packaging of brome mosaic virus RNA3 is mediated through a bipartite signal. *J. Virol.* 77:9750-9757.
- Choi, Y.G., Dreher, T.W. and Rao, A.L.N. 2002. tRNA elements mediate the assembly of an icosahedral RNA virus. *Proc. Natl. Acad. Sci. USA* 99:655-660.
- Damayanti, T.A., Tsukaguchi, S., Mise, K. and Okuno, T. 2003. *Cis*-acting elements required for efficient packaging of brome mosaic virus RNA3 in barley protoplasts. *J. Virol.* 77:9979-9986.
- Davis, P.B. and Pearson, C.K. 1978. Characterization of density gradients prepared by freezing and thawing a sucrose solution. *Anal. Biochem.* 91:343-349.

- Fox, J.M. 1994. RNA-protein interactions in icosahedral virus assembly. *Semin. Virol.* 5:51-60.
- Gould, A. R. and Symons, R. H. 1982. Cucumber mosaic virus RNA 3. *Eur. J. Biochem.* 126:217-226.
- Guilley, H. and Briand, J. P. 1978. Nucleotide sequence of turnip yellow mosaic coat protein mRNA. *Cell* 15:113-122.
- Hacker, D.L. 1995. Identification of a coat protein-binding site on southern bean mosaic virus RNA. *Virology* 207:562-565.
- Juzumiene, D., Shapkina, T., Kirillov, S. and Wolenzien, P. 2001. Short-range RNA-RNA crosslinking methods to determine rRNA structure and interactions. *Methods* 25:333-343.
- Koev, A. and Miller, W.A. 2000. A positive-strand RNA virus with three very different subgenomic RNA promoters. *J. Virol.* 74:5988-5996.
- Krishna, N.K. and Schneemann, A. 1999. Formation of an RNA heterodimer upon heating of nodavirus particles. *J. Virol.* 73:1699-1703.
- Lee, L., Kaplan, I.B., Ripoll, D.R., Liang, D., Palukaitis, P. and Gray, S.M. 2005. A surface loop of the potato leafroll virus coat protein is involved in virion assembly, systemic movement, and aphid transmission. *J. Virology* 79:1207-1214.
- Lee, Y.S., Lin, B. Y., Hsu, Y.H., Chang, B.Y. and Lin, N.S. 1998. Subgenomic RNAs of bamboo mosaic potexvirus-V isolate are packaged into virions. *J. Gen. Virol.* 79:1825-1832.
- Mohan, B.R., Dinesh-Kumar, S.P. and Miller, W.A. 1995. Genes and cis-acting sequences involved in replication of barley yellow dwarf virus-PAV RNA. *Virology* 212:186-195.
- Prufer, D., Wipf-Scheibel, C., Richards, K., Guilley, H., Lecoq, H. and Jonard, G. 1995. Synthesis of a full-length infectious cDNA clone of cucurbit aphid-borne yellows virus and its use in gene exchange experiments with structural proteins from other luteoviruses. *Virology* 214:150-158.
- Qu, F. and Morris, T.J. 1997. Encapsidation of Turnip crinkle virus is defined by a specific packaging signal and RNA size. *J. Virol.* 71:1428-1435.
- Rao, A.L.N. 2006. Genome packaging by spherical plant RNA viruses. *Annu. Rev. Phytopathol.* 44:61-87.

- Reeder, J., Steffen, P. and Giegerich, R. 2007. pknotsRG: RNA pseudoknot folding including near-optimal structures and sliding windows. *Nucl. Acids Res.* 35:W320-W324.
- Reutenauer, A., Ziegler-Graff, V., Lot, H., Scheidecker, D., Guilley, H., Richards, K. and Jonard, G. 1993. Identification of beet western yellows luteovirus genes implicated in viral replication and particle morphogenesis. *Virology* 195:692-699.
- Sacher, R. and Ahlquist, P. 1989. Effects of deletions in the N-terminal basic arm of brome mosaic virus coat protein on RNA packaging and systemic infection. *J. Virol.* 63:4545-4552.
- Sambrook, J. and Russel, D.W. 2001. Molecular cloning- A laboratory manual, 3rd edition, Cold Spring harbor lab press, NY. P. 999.
- Sit, T. L., Leclerc, D. and Abouhaidar, M. G. 1994. The minimal 5' sequence for *in vitro* initiation of papaya mosaic potexvirus assembly. *Virology* 199:238-242.
- Sit, T.L., Vaewhongs, A.A. and Lommel, S.A. 1998. RNA-mediated transactivation of transcription from a viral RNA. *Science* 281:829-832.
- Vriend, G., Verduin, B.J. and Hemminga, M.A. 1986. Role of the N-terminal part of the coat protein in the assembly of cowpea chlorotic mottle virus. A 500 MHz proton nuclear magnetic resonance study and structural calculations. *J. Mol. Biol.* 191:453-460.
- Whirl-Carrillo, M., Gabashvili, I.S., Bada, M., Banatao, D.R. and Altman, R.B. 2002. Mining biochemical information: lessons taught by the ribosome. *RNA* 8:279-289.
- Yamagishi, N., Terauchi, H., Kanematsu, S. and Hidaka, S. 2003. Characterization of the small subgenomic RNA of *Soybean dwarf virus*. *Arch. Virol.* 148:1827-1834.
- Zhao, X., Fox, J.M., Olson, N.H., Baker, T.S. and Young, M.J. 1995. *In vitro* assembly of cowpea chlorotic mottle virus from coat protein expressed in *Escherichia coli* and *in vitro*-transcribed viral cDNA. *Virology* 207:486-494.
- Zimmern, D. 1977. The nucleotide sequence at the origin for assembly on tobacco mosaic virus RNA. *Cell* 11:463-482.

Table 4.1. Differences in readthrough domain amino acid sequences in *Soybean dwarf virus* isolate W4 compared to CIIL2 and CIAgt2 isolates.

Isolate	Amino acid positions in the readthrough domain																
	255	340	462	466	470	472	473	474	475	503	514	534	552	575	607	639	664
CIIL2	S	V	E	M	F	E	E	D	N	Y	T	T	R	A	E	K	K
CIAgt2	S	V	E	M	F	E	E	D	N	Y	T	T	R	A	E	K	K
W4	P	L	I	T	D	D	G	Y	S	C	I	M	K	T	G	N	R

Table 4.2. Differences in nucleotide sequences of 3' untranslated regions (UTRs) in *Soybean dwarf virus* isolate W4 compared to CIIL2 and CIAgt2 isolates.

Isolate	Nucleotide positions in the 3' UTR ^a															
	5131	5134	5200								5211	5460	5528	5551	5642	5653
CIIL2	T	T	G	-	-	-	-	-	-	-	C	T	A	C	A	T
CIAgt2	T	T	G	-	-	-	-	-	-	-	C	T	A	C	A	T
W4	C	G	A	A	A	A	A	A	A	A	S	C	G	T	G	C

^aIn the 3' UTRs, out of the 9 nucleotide changes, four were located in the predicted Small subgenomic RNA region (position 5490-5709). In addition to these changes, seven 'A' insertions were observed in the W4 isolate in between 5200 and 5201 positions.

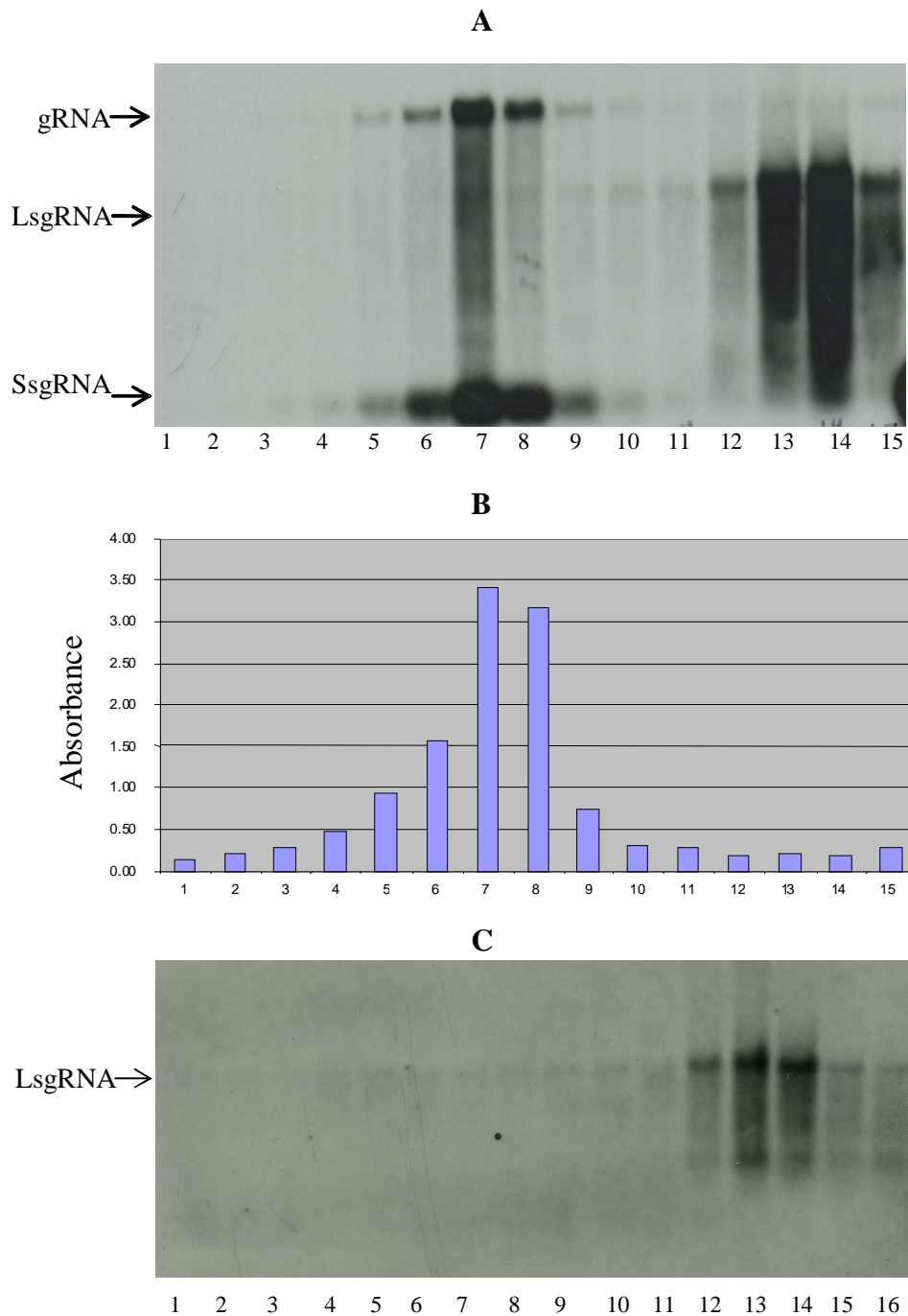

Figure 4.1. (A and B) Northern blot and DAS-ELISA on sucrose-gradient fractions of purified *Soybean dwarf virus* virions from *Nicotiana benthamiana* tissues agroinfiltrated with isolate CIIL2. RNAs were extracted from gradient fractions, separated on agarose gels, transferred to nylon membranes and hybridized with a 3'-specific biotinylated probe. Fractions were also subjected to DAS-ELISA. Genomic RNA (gRNA) and small subgenomic RNA (SsgRNA) were present in DAS-ELISA-positive fractions. The large subgenomic RNA (LsgRNA) was primarily located at the tops of sucrose gradients. **(C)** Northern blot of RNAs extracted from gradient fractions prepared from *N. benthamiana* tissues infiltrated with a mutant of isolate W4 with a deletion of open reading frame 3.

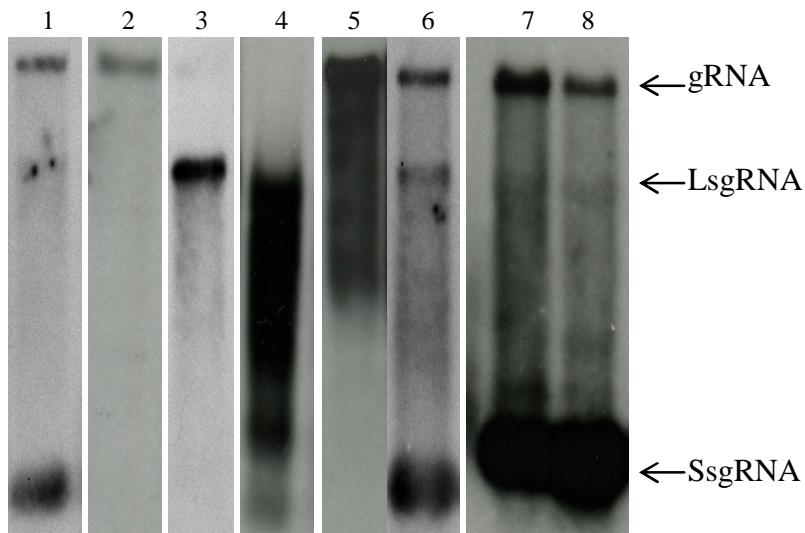

Figure 4.2. Encapsidated RNA content in virions of *Soybean dwarf virus* (SbDV) isolates CIagt2 and W4. RNA contents of sucrose gradient fractions corresponding to the virus peaks and the tops of gradients were subjected to northern blot analysis. Lane 1: virus peak in CIagt2, Lane 2: virus peak in W4, Lane 3: top gradient fraction in CIagt2, Lane 4: top gradient fraction in W4, Lane 5: CIIL2 virus peak hybridized with a 5' probe, Lanes 6, 7 and 8: total RNA from CIagt2-, W4-, and CIIL2-infected tissues, respectively. Only gRNA of isolate CIIL2 hybridized with the 5' probe. The migrations of SbDV genomic RNA (gRNA), large subgenomic RNA (LsgRNA) and small subgenomic RNA (SsgRNA) are indicated.

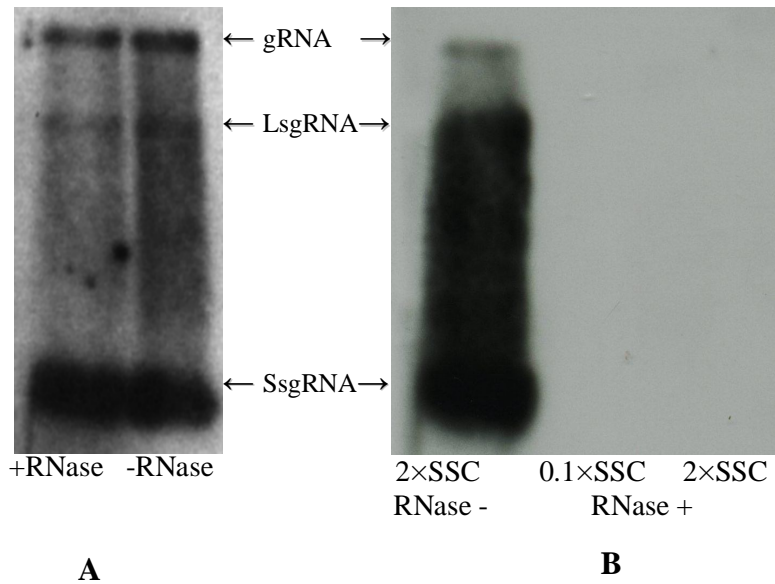

Figure 4.3. RNase sensitivity assay on *Soybean dwarf virus* (SbDV) virions and virion derived RNAs. **(A)** Virions purified from 10 g of soybean tissue infected with isolate ClAgt2 were digested with RNase A at a final concentration of 5 $\mu\text{g/ml}$ sample for 30 min at 37°C followed by proteinase K treatment at a final concentration of 100 $\mu\text{g/ml}$ for 30 min at 37°C. From the RNase treated virions, RNAs were extracted, separated on agarose gels, blotted to nylon membranes and hybridized with 3'-proximal biotinylated probe. Both RNase A treated and untreated samples showed all three viral RNAs. **(B)** Virion RNAs extracted from 2.5 g ClAgt2-infected soybean tissue were treated with RNase A (in 0.1xSSC and 2xSSC) followed by proteinase K and immediately subjected to northern blot as described. None of the viral RNAs survived the digestion with RNase enzyme. The migrations of SbDV genomic RNA (gRNA), large subgenomic RNA (LsgRNA) and small subgenomic RNA (SsgRNA) are indicated.

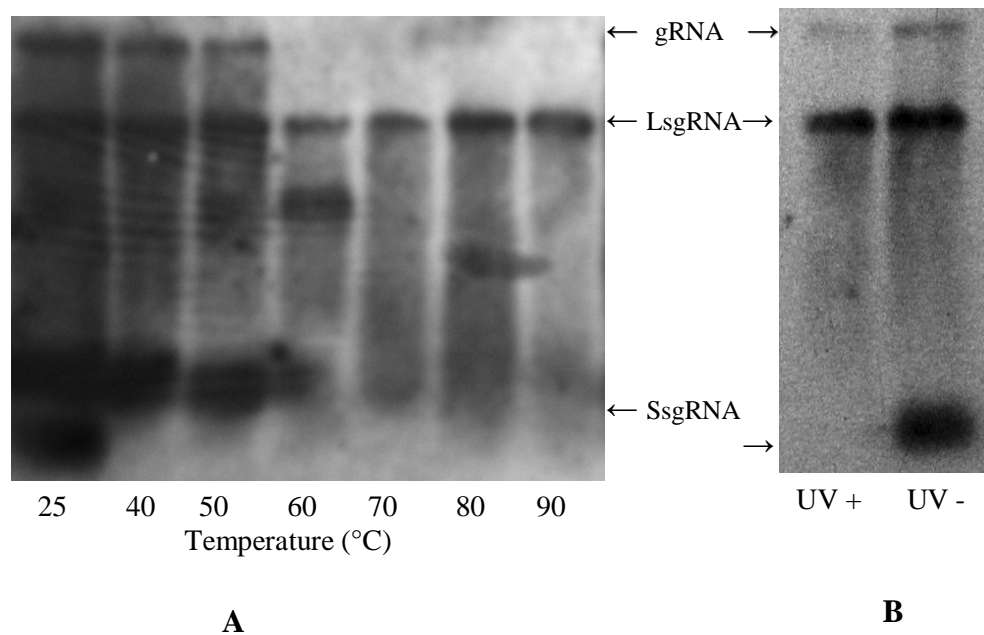

Figure 4.4. RNA crosslinking analyses on *Soybean dwarf virus* virions. **(A)** Virions of isolate ClAgt2 were purified from infected soybean tissue and incubated at the indicated temperatures for 10 min. Virion RNAs were extracted, electrophoresed and hybridized. Both genomic RNA (gRNA) and small subgenomic RNA (SsgRNA) disappeared at or above 60°C due to denaturation of the CP, but the large subgenomic RNA (LsgRNA) survived even at 90°C. **(B)** ClAgt2 virions purified from infected soybean tissues were exposed to UV radiation and subsequently digested with proteinase K. The SsgRNA is absent in UV-treated sample.

```

                    5468                    5490                    5533                    5543
ClIL2RTP3' : GGTCACTCCGTGAAAAGAGAGTGGCTAA-TACGCCCCTTCGACGGCGTTAAATGAAAGCGTAGGTCACACGACACCCCCTGTCAAGGACA
RACE55      : -----TAAAAACGCCCTTCGACGGCGTTAAATGAAAGCGTAGGTCACACGACACCCCCTGTCAAGGACA
RACE5       : -----CCGTGAAAAGAGAGTGGCTAA-TACGCCCCTTCGACGGCGTTAAATGAAAGCGTAGGTCACACGACACCCCCTGTCAAGGACA
RACE510     : -----AAACGCCCTTCGACGGCGTTAAATGAAAGCGTAGGTCACACGACACCCCCTGTCAAGGACA
RACE511     : -----ACGCCCCTTCGACGGCGTTAAATGAAAGCGTAGGTCACACGACACCCCCTGTCAAGGACA
RACE3       : -----ACGCCCCTTCGACGGCGTTAAATGAAAGCGTAGGTCACACGACACCCCCTGTCAAGGACA
RACE57      : -----ACGCCCCTTCGACGGCGTTAAATGAAAGCGTAGGTCACACGACACCCCCTGTCAAGGACA
RACE59      : -----ACCCCCTGTCAAGGACA
RACE56      : -----ACCCCCTGTCAAGGACA
RACE54      : -----ACCCCCTGTCAAGGACA
RACE7       : -----CCCCCTGTCAAGGACA
RACE53      : -----CCCCTGTCAAGGACA
RACE52      : -----AAGGACA

```

5' RACE

```

                                5709
ClIL2RTP3' : CAGGTCCACCTGCCCC
RACE10     : CAGGTCCACCTGCCCC
RACE13     : CAGGTCCACCTGCCCC
RACE16     : CAGGTCCACCTGCCCC

```

3' RACE

Figure 4.5. Nucleotide sequences of products of RNA ligase-mediated rapid amplification of cDNA ends (RLM-RACE) of encapsidated small RNAs from *Soybean dwarf virus*. Small RNAs from virions were polyadenylated, ligated to a 5'-RNA adapter, reverse transcribed using an oligo(dT) primer, amplified in two separate polymerase chain reactions using adapter-sequence primers and gene-specific primers, cloned into pCR2.1-TOPO and sequenced. The 3'-RACE products ended exactly at position 5709, like in genomic RNA, while 5'-RACE products showed different start sites.

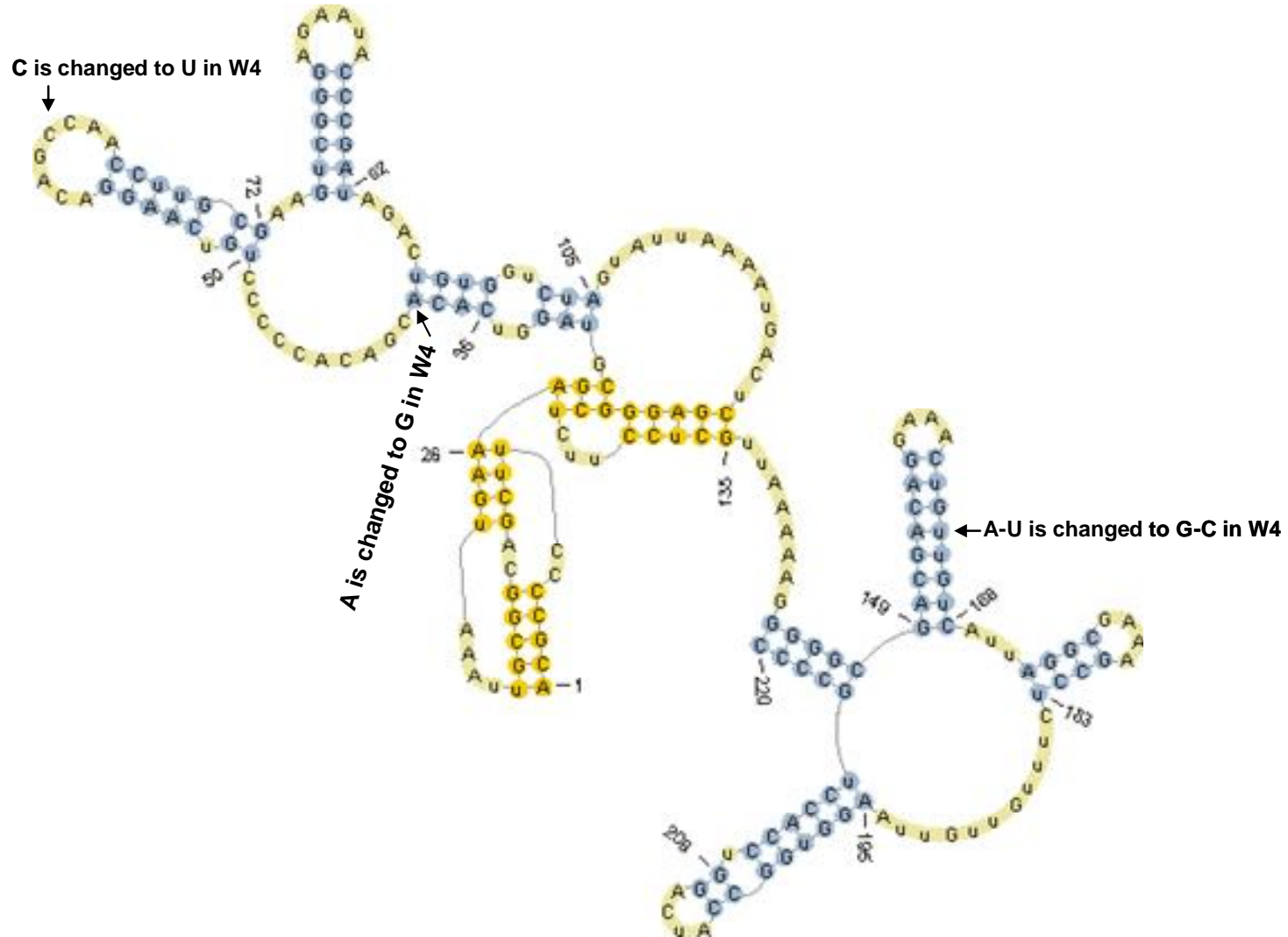

Figure 4.6. Predicted structure of small subgenomic RNA (SsgRNA) of CIIL2 isolate of *Soybean dwarf virus*. The structure of SsgRNA was derived by pknotsRG software (Reeder *et al.*, 2007). The positions of nucleotide changes with that of W4 isolate are indicated in the figure.

CHAPTER 5

ROLE OF REPLICATION, LONG-DISTANCE RNA-RNA INTERACTIONS AND CODING SEQUENCES IN ENCAPSIDATION OF *SOYBEAN DWARF VIRUS*

ABSTRACT

Replication and encapsidation of viral RNAs require specific interaction of *cis*-acting sequences and viral encoded proteins. The effect of mutations in coding and interacting stem-loop structures in the 5' and 3' untranslated regions (UTRs) on encapsidation of *Soybean dwarf virus* (SbDV) RNAs was investigated. Mutations were introduced into a full-length infectious clone of SbDV by deletion of open reading frames (ORFs) and site-specific mutagenesis in the 5' and 3' UTRs and catalytic core of the replicase gene. *Nicotiana benthamiana* leaves were infiltrated with *Agrobacterium tumefaciens* harboring mutant clones alone and with wild-type helper virus. Analysis of total RNA content revealed that all mutants, except ORF deletion (Δ ORF) mutants, Δ ORF3 and Δ ORF5, and 5'-3' UTR double mutant, were replication defective. In the UTR double mutant, low-level viral replication was observed when nucleotide substitutions were introduced that restored interaction between 5'- and 3'-stem-loops structures. This study showed that all coding regions, except ORF3 and 5 and the interacting stem-loops in the 5' and 3' UTR, are involved in replication of SbDV. Also, the roles of readthrough domain protein and 3' UTR in differential packaging of the small subgenomic RNA (SsgRNA) of SbDV were analyzed by replacing these regions of an infectious clone of an isolate that did not package SsgRNA with the corresponding regions from an isolate that did. These experiments indicated that the 3' UTR was involved in SsgRNA encapsidation. Non-replicating mutants were trans-encapsidated by coat protein provided by replicating wild-type virus, which suggested that encapsidation of SbDV genomic RNA (gRNA) was independent of replication. In competitive packaging assays, preferential encapsidation of large subgenomic RNA (LsgRNA) and mutant gRNA was observed in tissues co-infiltrated with wild-type virus and Δ ORF1 and Δ ORF5 mutants, respectively. The

present study indicated possibility of two interacting signals that differentially regulate encapsidation of gRNA and LsgRNA.

INTRODUCTION

Replication and assembly of infectious virions are important events in the life cycle of most RNA viruses. Replication of single-stranded, positive-sense RNA viruses involves specific interactions between viral replication complexes, composed of virus-encoded RNA-dependent RNA polymerases (RdRps), host factors, and their cognate RNA templates (Song and Simon, 1995). Viral replicases identify *cis*-acting sequences or signals in genomic RNA (gRNA) to synthesize minus-strand RNAs and then new plus-strand RNAs are replicated from minus-strand templates.

Similarly, the high specificity of viral RNA encapsidation requires recognition of viral RNAs by the structural proteins. Protein-protein interaction and sequence-dependent and sequence-independent protein-RNA and RNA-RNA interactions play crucial roles in precise assembly and packaging of viral genomes (Rao, 2006). Auxiliary factors influencing virion assembly in RNA viruses are host tRNAs (Marquet *et al.*, 1995), viral replicase (Nugent *et al.*, 1999; Khromykh *et al.*, 2001; Venter *et al.*, 2005) and accessory proteins, like scaffolding proteins (Rixon, 1993). While some plant viruses spontaneously assemble *in vitro*, many do not. Unsuccessful *in vitro* assembly of these plant viruses could be due to the transient involvement of accessory proteins such as virus-encoded replicase or host proteins associated with the compartment where assembly occurs (Rao, 2006).

Roles of coding region sequences in packaging

Coat protein (CP)

The first 25 amino acids at the 5' end of bromovirus CPs are believed to play an important role in RNA recognition during encapsidation of bromovirus RNAs (Vriend *et al.*, 1986; Sacher and Ahlquist, 1989; Fox, 1994; Zhao *et al.*, 1995). In *Turnip crinkle virus* (TCV), a series of

deletions in the genome demonstrated that a 186 nucleotide (nt) fragment at the 3' end of the CP coding region is responsible for specific packaging and that a 28-nt bulged hairpin loop within this region is the most essential element of the packaging core (Qu and Morris, 1997).

Viral replicase

The involvement of viral replicase in virion assembly has been demonstrated in non-plant RNA viruses (Nugent *et al.*, 1999; Khromykh *et al.*, 2001; Venter *et al.*, 2005). For most plant viruses, high level expression of individual gene products and their assembly into virions require complete replication. Lack of suitable *in vivo* systems independent of replication hindered the research progress in elucidating the role of replicase in packaging of plant viruses. This was overcome by the development of agroinfiltration systems in which leaf tissues are infiltrated with *Agrobacterium tumefaciens* harboring plasmids that transiently express modified viral RNAs under the control of strong constitutive promoters, like the *Cauliflower mosaic virus* (CaMV) 35S. Agroinfiltration allowed the separation of the requirement for encapsidation from that of viral replication. Simultaneous infiltration of plants with *A. tumefaciens* transformed with different plasmids results in the transfer of multiple transgenes from T-DNAs into the same cell where they are transcribed and coordinately expressed. *In vivo* encapsidation systems using transient expression of viral RNAs through agroinfiltration have been developed for a few plant viruses (Vlot *et al.*, 2001; Annamalai and Rao, 2005).

Expression of *Brome mosaic virus* (BMV) RNAs and CP subunits *in trans* through agroinfiltration revealed that packaging of BMV RNAs is not replication dependent so that autonomously expressed full-length gRNA and replication deficient RNAs 1 and 2 were efficiently packaged by the CP expressed *in trans* (Annamalai and Rao, 2005). Similar observations were reported in monopartite *Turnip yellow mosaic virus* (TYMV; Cho and Dreher, 2006). However, replicase was proved to be involved in the specificity of viral RNA encapsidation by blocking the host RNAs being packaged and maintaining the physical separation of host and viral RNAs in viruses such as BMV (Annamalai and Rao, 2005), *Flock house virus* (FHV; Venter *et al.*, 2005) and *Sesbania mosaic virus* (SeMV; Lokesh *et al.*, 2002).

Role of coding region sequences in replication

The roles of cis-acting coding sequences and proteins encoded by them in viral replication have been identified through experiments involving deletion mutants. In BMV, a mutant with a deletion in RNA 2 of the region encoding RdRp did not replicate to detectable levels (Pogue *et al.*, 1990). In luteoviruses, other than open reading frames (ORFs) that encode replication related proteins, all other coding regions are dispensable for viral replication, although deletion of the CP-encoding region reduced the efficiency of viral replication (Sacher and Ahlquist, 1989; Reutenauer *et al.*, 1993; Mohan *et al.*, 1995). Similarly, reduction in BMV replication was observed in mutants with deletion of movement protein and CP cistrons from RNA 3 (French and Ahlquist, 1987). In *Tobacco mosaic virus* (TMV), mutant lacking CP and movement protein sequences were defective in minus-strand RNA synthesis (Ishikawa *et al.*, 1991) and removal of 5' terminal half of movement protein reduced the synthesis of subgenomic RNA for the CP synthesis (Ogawa *et al.*, 1992).

Role of non-coding sequences in replication and packaging

Intramolecular base pairing in the 3' un-translated region (UTR) of a wide range of plant viral RNAs results in the formation of aminoacylatable tRNA-like structures (TLS; Dreher, 1999) or stem-loop structures/hair pins (Wang *et al.*, 1999) that are important for viral replication and translation initiation. In BMV, RNAs lacking TLS failed to assemble into virions. Assembly was restored when the TLS was provided either *in cis* or *in trans* (Choi *et al.*, 2002). Conversely, 3' TLS was not essential for packaging in *Alfalfa mosaic virus* (Vlot *et al.*, 2001). Also, stem-loop structures near the 3' end of the viral genome can interact with stem-loop structures in the 5' UTR. These long-distance RNA-RNA interactions are essential in translation initiation, replication (Miller and White, 2006) and packaging (Rao, 2006) of plant viruses (Figure 5.1).

Packaging signals can be located anywhere in the viral genome. In the family *Luteoviridae*, *Barley yellow dwarf virus* (BYDV), *Beet western yellows virus* (BWYV) and *Cucurbit aphid-borne yellows virus* (CABYV) package gRNAs into virions but not subgenomic RNAs

(sgRNAs) (Reutenauer *et al.*, 1993; Mohan *et al.*, 1995; Prufer *et al.*, 1995). These observations suggested that sequences upstream of the regions that represent the sgRNAs have crucial roles in packaging. In the luteoviruses, this region includes ORFs 1 and 2, which encode viral replicases, and the 5' UTR. Hence, this study was conducted to investigate the effects of deletion and point mutations in the coding regions and 3' and 5' UTRs on replication and encapsidation of SbDV. Because packaging of small subgenomic RNA (SsgRNA) by some SbDV isolates suggested that the assembly of SsgRNA requires a packaging signal located near the 3' end of the gRNA, experiments were also conducted to test the involvement of 3' UTR in the encapsidation of SbDV SsgRNA.

MATERIALS AND METHODS

Construction of ORF deletion mutants

To identify genomic regions and functions required for replication and packaging of SbDV RNAs, a series of deletion mutants were constructed by removing each ORF from a full-length clone of soybean SbDV isolate, Wisc4 (W4). To create deletion mutants for ORFs 1, 2, 3, 4 and 5, two polymerase chain reactions (PCRs) were designed for each mutant. A reverse primer was designed for PCR I using the sequences immediately preceding the 5' end of the ORF that was to be removed, and a forward primer was designed for PCR II from sequences immediately after the 3' end of that ORF (Figure 5.2). A high fidelity DNA polymerase, Ex *Taq*, was used to amplify the required regions from the W4 isolate cloned in binary vector pCZ14 (hereafter mentioned as wild-type or pCZ14W4). Restriction enzymes (*SalI* for ORF1, *XbaI* for ORF2, *MluI* for ORFs 3 and 4, and *ApaI* for ORF5) were incorporated into the PCR primers for the respective deletion mutants to facilitate cloning. The details of primers and the cycles used for PCR are presented in Table 5.1.

ORF1 deletion mutant (Δ ORF1)

PCR product I and pCZ14W4 were sequentially digested with *HindIII* and *SalI* at 37°C for 2.5 hr each and the required fragments were gel purified. The purified PCR I fragment was ligated to

pCZ14W4 from which the corresponding fragment had been removed by *HindIII* and *SalI* digestion (Figure 5.2). *Escherichia coli* cells (DH10B) were transformed with ligation mixture and screened on Luria-Bertani (LB) plate with kanamycin. Plasmids were extracted from colonies by the alkaline-lysis method (Sambrook and Russell, 2001) and digested with *HindIII* and *SalI*. Colonies harboring plasmids with the required size of insert (plasmid I) were cultured overnight and purified using QIAprep Spin Miniprep Kit (Qiagen Inc. Valencia, CA). The plasmid I and the PCR II product were then digested with *SalI* and *XbaI* and the required fragments were purified from agarose gels and cloned. The incorporation of PCR II into plasmid I (Δ ORF1 mutant) was confirmed with *SalI* and *XbaI* digestion of extracted plasmids from transformed *E. coli*.

The Δ ORF1 plasmid was also digested with *EcoRI* and *HindIII* and the digestion pattern was compared to that of the wild-type clone to confirm the deletion of ORF1. The plasmid was also sequenced with primers CaMV*HindIII*, 1F and 1691R (5'-CCTGGGTGCTATCTTCTTACA-3') to confirm the deletion of 1107 bp. This mutant plasmid and all subsequent constructs were introduced into disarmed *Agrobacterium tumefaciens* strain KYRT1 by electroporation, purified and digested with diagnostic restriction enzymes (e.g., *EcoRI* and *HindIII* or *XbaI* and *MluI*) to confirm the incorporation of the intact plasmids into *Agrobacterium*.

ORF2 deletion mutant (Δ ORF2)

The Δ ORF2 mutant was constructed similarly to ORF1. The pCZ14W4 plasmid was digested with *SalI* and *XbaI* to remove a 1069-bp fragment, and ligated to the PCR I product digested with the same enzymes. The resultant plasmid I and PCR II were digested with *XbaI* and *ApaI* enzymes and ligated to produce the Δ ORF2 mutant. To confirm the deletion of 1531-bp ORF2, the Δ ORF2 plasmid was digested with *EcoRI* and *HindIII* and sequenced with SbdV primers 79F (5'-CGGCATCTTCGTATCGTGT-3'), 680F (5'-GGTTCAACACTCTGCCCAATAGAATGA-3'), 3148R (5'-CGTCGTTGTCTTCTTCKGC-3'), 3742R (5'-AGTGTTGACAGTGTACCGGT -3') and 3847F (5'-CGCAATGGTACTCACAGAATT-3').

ORF3 (Δ ORF3) and ORF4 (Δ ORF4) deletion mutants

In SbdV, ORF3 encodes CP and encloses the sequences of ORF4 in a different translational frame. To construct Δ ORF3 and Δ ORF4 mutants, pCZ14W4 was digested with enzymes *Xba*I and *Apa*I, gel purified the plasmid fragment and used to clone the PCR I product. The resultant plasmid was linearized with *Mlu*I and *Apa*I and ligated to the PCR II fragment that had been digested with the same restriction enzymes. To confirm the deletion of 603-bp ORF3 and 571-bp ORF4, the mutant plasmids were digested with *Mlu*I and *Apa*I and *Eco*RI and *Hind*III and compared with the digestion pattern of wild-type pCZ14W4 plasmid. In addition, mutant plasmids were sequenced with 1231F, 2563F (5'-AGGACAAACTCGGGCTCAGGAAAG-3'), 3742R and 3847F primers to confirm the deletions.

ORF5 deletion mutant (Δ ORF5)

To delete ORF5, which encodes the readthrough domain (RTD), pCZ14W4 was digested with *Xba*I and *Apa*I, and gel purified. The PCR I product was treated with the same restriction enzymes and cloned into the cleaved pCZ14W4. The plasmid I thus obtained was linearized by sequential digestion with *Apa*I and *Xma*I enzymes. The ligation of plasmid I to *Apa*I and *Xma*I-treated PCR II product yielded a SbdV mutant devoid of ORF5. The deletion of 1470 bp was confirmed by digestion with *Eco*RI and *Hind*III and sequencing with primers 1231F, 3248F (5'-GGAACTATCACTTTCGGGCCG-3'), 5116F (5'-GCGCTTTCATTGTCAAGTAT A-3') and 5234R (5'-GGATATGCAACCGAAAGTGATA-3').

Involvement of 5' and 3' UTR interactions in SbdV replication and encapsidation

To investigate the involvement of long-distance RNA-RNA interactions between stem-loop structures in the 5' and 3' UTRs in the replication and packaging of SbdV, site-directed PCR mutagenesis was used to introduce mutations in these regions. In the W4 isolate of SbdV, nt sequences at positions 9-13 in the stem-loop structure in the 5' UTR are predicted to be involved in long-distance interaction with sequences at positions 5219-5223 (Figure 5.3) in a stem-loop structure present in the 3' UTR (Guo *et al.*, 2001). In order to analyze the involvement of this interaction in SbdV replication and encapsidation, a single nt substitution was introduced by

changing the A at position 11 to U in the 5' stem-loop structure. This mutation will block the long distance interaction of 5' and 3' UTR stem-loops. To restore the interaction of 5' and 3' UTR stem-loops, a second single nt substitution was introduced into the 3' stem-loop structure at position 5221 by changing the sequences from U to A.

Construction of 5' UTR mutant

A 300-bp blunt-ended mutated PCR product was amplified from the pCZ14W4 using a high fidelity polymerase (iProof, Bio-Rad Laboratories, Hercules, CA), a mismatch primer, 5'MutF (5'-AGTAAAGTTGTCACCTTTACAGAAGTGTTTC-3', nt substituted is underlined), and 300R (5'-CCATACATGGCGTCGTAGCA-3'). The thermal cycling program used for the reaction was 30 cycles of 98°C for 30 s, 98°C for 8 s, 64°C for 20 s and 72°C for 8 s. The PCR product was digested with *SalI*, gel purified, and cloned into the binary vector pCZ14 linearized with *SalI* and *StuI*. *Escherichia coli* cells were transformed with ligation mixture and screened on LB plate with kanamycin. Plasmids having inserts (plasmid I) were identified by digestion with *XbaI* and *HindIII*.

The Full-length SbDV genome was amplified using primers 1F and 5688R and *ExTaq* polymerase with 40 cycles of 94°C for 30 s, 55°C for 30 s, and 72°C for 6 min. The products were sequentially digested with *SalI* and *XmaI*, and the required 5.4-kb fragment was gel purified, and ligated with *SalI* and *XmaI* linearized plasmid I to obtain SbDV full-length cDNA clone that has a single nt substitution in the interacting 5' UTR sequence. The 5' UTR mutated plasmid was digested with *EcoRI* and *HindIII* to verify the incorporation of full-length SbDV into the plasmid. To confirm the incorporation of extreme 5' and 3' ends of the virus and the mutated sequence, sequencing reactions were also performed with primers 300R, CaMV*HindIII* and 5116F.

Construction of 3' UTR mutant

To construct 3' UTR mutant, an overlap-extension PCR was designed with two mismatch primers that substituted single nt in plus- and minus-strands. The mismatch primers had the

single nt substitution at their 5' end and at least 15 nt overlapping sequences. PCR I was carried out with Ex *Taq* polymerase and pCZ14W4 plasmid with a mismatch primer, Mut5226R (5'-AGCTGTCATCTCCCCGAGATTA-3', mutated sequence is underlined) and 3847F. Thermal cycling conditions were 30 cycles of 94°C for 30 s, 54°C for 30 s and 72°C for 90 s. PCR II was performed with another mismatch primer, Mut5215F (5'-GAGATGACAGCTCCCCGTCGT-3', mutated sequence is underlined) and 5688R with 30 cycles of 94°C for 30 s, 57°C for 30 s and 72°C for 30 s.

The products of PCR I and PCR II were purified and approximately 100 ng of mixture containing equal copy number of each product was used as the template for the third PCR with the two outer primers (3847F and 5688R). The product of PCR III was digested with *Apa*I and *Xma*I, gel extracted, and cloned into pCZ14W4 that was digested with same enzymes. Plasmids extracted from transformed *E. coli* cells were digested with *Eco*RI and *Hind*III to confirm the insertion of PCR III. Sequencing reactions were performed with 4571F (5'-TGCTGATGTCATGAAGTTCTCC-3'), 5116F (5'-GCGCTT TCCATTGTCAAG TATA-3') and 5493R (5'-CGCTTTCATTTAACGTCATCAAAGGG-3') to verify the nt substitution.

Construction of 5'-3' UTR double mutant

To construct 5'-3' UTR double mutant, the 5' and 3' UTR mutants were digested with *Ahd*I and *Xma*I. The resulting 14.5 kb pCZ14W4 fragment from 5' UTR mutant that contained the 5' UTR substitution and a 800-bp fragment from 3' UTR mutant that contained the 3' UTR substitution were gel purified, and ligated to get a new plasmid that contained both mutations in the SbDV genome. The cloning of these two pieces was verified by double digestion of the plasmids extracted from the transformed *E. coli* colonies with *Ahd*I and *Sma*I and *Eco*RI and *Hind*III. Sequencing reactions were also performed with primers 4571F, 5531F (5'-ACACCCCCTGTCAAGGACAG-3'), 300R and 5520R (5'-ACGCTTTCATTTAACGCCAT-3') to confirm the single nt substitutions at the 5' and 3' UTRs.

Role of viral replication in SbDV gRNA encapsidation

To analyze whether packaging of SbDV gRNA is dependent upon replication, a non-replicating SbDV mutant and a clone that transcribed LsgRNA, from which CP, readthrough protein (RTP) and putative movement protein are translated, were constructed. In replication-deficient mutants, minus-strand RNA would not be synthesized from the gRNA and, thus, no sgRNAs would be made. The LsgRNA construct was expected to provide CP, RTP and putative movement protein *in trans* when co-infiltrated with the replicase mutant in *N. benthamiana*.

Construction of non-functional replicase mutant

Mutations in one of the three amino acids (GDD) in the functional domain of the replicase enzyme resulted replication-deficient mutants in TYMV (Cho and Dreher, 2006). In the present study, amino acids GDD (Gly-Asp-Asp) encoded by nt sequences GGC GAT GAT (positioned at 2169-2177 in SbDV W4) were mutated to DAY (Asp-Ala-Tyr, encoded by GAC GCG TAT) by four nt substitutions (nt underlined). This was done by overlap-extension PCR mutagenesis using two mismatch primers with overlapping sequences and pCZ14W4 as a DNA template. These substituted sequences also introduced a restriction site for the enzyme, *MluI*, (GACGCGTAT, restriction site underlined), which did not have a recognition site within pCZ14W4.

Construction of the mutant was carried out as in the case of 3' UTR mutant by three PCRs. First, a 953-bp product was amplified in a PCR (30 cycles of 94°C for 30 s, 60°C for 30 s and 72°C for 2 min) using primers 1231F and MluIR (5'-ACAATACGCGTCGTTATTGCAGAGTTC-3', mismatches underlined). A second PCR product was amplified using 30 cycles of 94°C for 30 s, 53°C for 30 s and 72°C for 3 min and primers MluIF (5'-AATAACGACGCGTATTGTGTTATCATATGC-3', mismatches underlined) and 4786R. The third PCR was conducted as described in the construction of the 3' UTR mutant plasmid with primers 1231F and 4786R. PCR conditions were 30 cycles of 94°C for 30 s, 53°C for 30 s and 72°C for 4 min. The PCR product and pCZ14W4 vector were digested with restriction enzymes *XbaI* and *ApaI*, recovered from agarose gels, ligated and transformed into *E. coli*. Plasmids were extracted from transformed *E. coli* cells and digested in two separate reactions with *XbaI* and

ApaI and *XbaI* and *MluI* enzymes to confirm the incorporation of mutated PCR III. A plasmid with the correct insert size was sequenced with 1864F (5'-AACGACCAGTTGCAATAGGTGTTGATG-3') and 2395R (5'-GCCATGGAAATGAGGGAATG-3') primers to verify the presence of mutated amino acid sequences in the replicase domain.

Construction of large subgenomic (Lsg) RNA clone

To construct a clone, that transcribed the LsgRNA under control of the CaMV 35S promoter, a PCR was designed that amplified the region corresponding to the LsgRNA (part of ORF2, UTR2, ORFs 3, 4, and 5 and 3' UTR) in SbDV. A restriction site for the enzyme *XbaI* was added at the 5' end of the forward primer, *XbaI*2719F (5'-ATTATTCTAGAGTAAAGAGATTGACGCCT-3', restriction site underlined) and PCR was carried out with *XbaI*2719F and 5688R and Ex *Taq* polymerase. The reaction conditions were 3 cycles of 94°C for 30 s, 48°C for 30 s and 72°C for 3 min followed by 26 cycles of 94°C for 30 s, 57°C for 30 s and 72°C for 3 min.

The PCR product was purified and digested with *XbaI* and *XmaI*, gel purified, and cloned into the binary vector pCZ14, linearized with the same enzymes. *Escherichia coli* cells were transformed with ligation mixture and screened on LB plates with kanamycin. Plasmids having inserts were identified by digestion with the same enzymes. Sequencing reactions were also performed with primers 5116F and 2961R to verify the incorporation of the 5' and 3' ends of the PCR product.

Involvement of RTP encoding RTD and 3' UTR in SbDV SsgRNA encapsidation

As described in Chapter 4, the study on packaged RNA content of three SbDV isolates revealed differential encapsidation of SsgRNA. The isolates varied at 17 amino acid positions at RTP and nine nt positions at the 3' UTR in which four were located in SsgRNA region. In order to analyze the role of these portions of the SbDV genome in SsgRNA packaging, an experiment was designed to replace these regions in the W4 isolate (does not package SsgRNA) with the corresponding regions from the CIIL2 isolate (packages SsgRNA).

Construction of UTR and RTP replacement mutants of W4 isolates

To replace the 3' UTR and RTD encoding (ORF5) regions of W4 with those of CIIL2, two separate double digestions of pCZ14W4 plasmid were carried out with *AhdI* and *XmaI*, and *ApaI* and *AhdI*. Sites for enzymes *ApaI* and *AhdI* were within the ORF5. When this region in W4 was replaced with that of CIIL2, 13 out of 17 amino acid differences between the two isolates were replaced. Replacement of the W4 3' UTR with that from CIIL2 included 171 nt at the 3' end of ORF5. Digested DNA fragments were gel purified. The restriction fragments of 733 bp (from *ApaI-AhdI* enzyme digestion) and 786 bp (from *AhdI-XmaI* enzyme digestion) of CIIL2 were ligated separately with the plasmid fractions of pCZ14W4 digested with the corresponding enzyme pairs. The *E. coli* cells were transformed and plasmids were screened. The plasmids with correct size of inserts were sequenced to verify the substitution of sequences between the *AhdI-XmaI* and *ApaI-AhdI* restriction sites in pCZ14W4.

Analysis of infectivity of mutant constructs

Agrobacterium harboring mutant constructs were cultured and infiltrated several times in *N. benthamiana* leaves as described in Chapter 2. For ORF deletion and UTR mutants, clones were infiltrated alone and in combination with the wild-type virus (pCZ14W4). The 5' and 3' UTR mutants were also co-infiltrated to analyze the re-establishment of the interactions between stem-loop structures in the 5' and 3' UTRs. The replicase mutant was infiltrated alone and in combination with the LsgRNA construct and with pCZ14W4. Six days after infiltration, leaves were collected and evaluated for replication and encapsidation of mutant RNAs by double-antibody sandwich enzyme-linked immunosorbent assay (DAS-ELISA) and northern blot, which were performed as described in previous chapters. Though northern blots on total RNA from 100 mg of infiltrated tissue was sufficient to detect replicating mutants and wild-type virus, the hybridization efficiencies of probes for the 3' UTR varied greatly. Probes made from extreme 3' end (nt positions 5116-5709) of the viral genome (both biotinylated DNA and minus-strand-specific *in vitro*-transcribed RNA probes) produced stronger hybridization signals than probes from other locations in the 3' UTR, but had higher background and detected plant RNAs. Unless

otherwise specified, a 219 bp biotinylated PCR product synthesized from the 3' UTR of SbDV (nt positions 5301-5520) that had minimal detection of plant RNAs was used as the hybridization probe.

Encapsidation studies on SbDV mutants

For the RTP and UTR replacement mutants, virus was purified by the method described in Chapter 4 and sucrose gradient fractions were analyzed by DAS-ELISA to identify the virus peak. Encapsidated RNA content of purified virus was analyzed on northern blots. In the case of non-replicating ORF deletion and replicase mutants, to find out if the mutated RNAs were packaged in presence of CP provided by replicating wild-type W4, *N. benthamiana* leaves were co-infiltrated with *Agrobacterium* harboring both mutant and wild-type plasmids. Virions were purified from 50 g of tissue, and RNAs were extracted from DAS-ELISA-positive sucrose gradient fractions. The RNAs were treated with TURBO DNase (TURBO DNA Free Kit, Ambion, Austin, TX) to remove contaminating *Agrobacterium* plasmid DNA, and reverse transcribed to cDNA with primer 5688R. For Δ ORF mutants, PCRs were designed with primers flanking the deleted ORF and the sizes of amplified products were compared between mutant and wild-type RNAs. For the replicase mutant, primers were designed to specifically amplify either the wild-type or mutated sequences. The details of these PCR primers and cycling conditions are presented in Table 5.2. In the case of Δ ORF mutants, samples also were subjected to northern-blot analysis. Encapsidation assays were not conducted on non-replicating UTR mutants.

RESULTS

Role of coding regions in SbDV replication

Construction of Δ ORF mutants of soybean SbDV isolate by incorporation of the products of PCRs I and II was confirmed by digestion of mutant plasmids with *EcoRI* and *HindIII* and sequence analysis (Figure 5.4A). These mutants were infiltrated into *N. benthamiana* leaves alone and in combination with the wild-type plasmid. When infiltrated alone, deletion of ORFs 1, 2, and 4, did not result in SbDV infection in infiltrated tissues (Table 5.3). Infiltrations and

northern blots were repeated several times to confirm the results. Mutant RNAs transcribed from the CaMV 35S promoter also were not detected in northern blots (data not shown).

Mutant devoid of ORF3 replicated and accumulated gRNA, LsgRNA, SsgRNA and RNAs smaller than SsgRNA in *N. benthamiana* tissues (Figure 5.4B; lane 1). The LsgRNA produced by the Δ ORF mutant was smaller than the LsgRNA transcribed from the wild-type virus. Synthesis of smaller-sized LsgRNA and negative DAS-ELISA confirmed the deletion of CP encoding ORF3. In the Δ ORF5 mutant, though the ELISA on infiltrated tissues was negative, northern blot showed the presence of RNAs smaller than LsgRNA and that co-migrated with SsgRNA (Figure 5.4B; lane 3). However, no gRNA was detected. Co-infiltration of Δ ORF mutants with wild-type W4 resulted in local infection of SbDV (Table 5.3) and northern blots on total RNAs of these co-infiltrated tissues detected all three wild-type viral RNAs, but not RNAs from the non-replicating mutants (Figure 5.4C).

Involvement of long-distance interactions between 5' and 3' UTRs in SbDV replication

Single-nt mutations were introduced into interacting stem-loop structures in the 5' and 3' UTRs of the W4 isolate of SbDV by site-directed PCR mutagenesis. Also, a double mutant, in which both 5' and 3' UTR mutations were incorporated, was constructed. Nucleotide sequence analysis verified the presence of mutations at respective sites in these clones. Northern blot and DAS-ELISA on agroinfiltrated *N. benthamiana* tissues did not detect SbDV RNAs (Figure 5.5; lanes 2 and 3) or CP (Table 5.3), suggesting that both 5' and 3' UTR mutants were replication defective. Though tissues co-infiltrated with 5' and 3' UTR mutants were ELISA negative, preferential replication of LsgRNA compared to gRNA and SsgRNA was observed in northern blots (Figure 5.5; lane 7). Tissues infiltrated with the 5'-3' double mutant were ELISA negative, but the SbDV probe detected gRNA in northern blots (Figure 5.5; lane 4). Tissues co-infiltrated with either the 5' or 3' UTR mutants and wild-type virus were ELISA positive and all three wild-type RNAs were observed in northern blots (Figure 5.5; lanes 5 and 8).

Role of coding regions and long-distance interactions between stem-loop structures in the 5' and 3' UTRs in SbDV encapsidation

Since ORF deletion mutants and 5' and 3' UTR mutants were not detected by DAS-ELISA when they were infiltrated alone in *N. benthamiana*, no encapsidation studies were conducted on these mutants. Non-replicating mutants were not expected to produce CP as it is derived from the LsgRNA through replication. For mutants that replicated at levels too low to be detected by ELISA, packaging studies were not conducted due to the lack of an efficient detection method. For the replicating Δ ORF3 mutant, virions were purified through sucrose gradient centrifugation and RNAs were extracted from each gradient and analyzed as described in Chapter 4. As expected, gradients tested negative to the DAS-ELISA and no viral RNAs were observed in the gradient at the position where intact virus was expected to sediment (Figure 4.1C). Even though the Δ ORF5 mutant synthesized SsgRNA, no packaging assay was conducted because it was ELISA negative, mutant gRNA transcribed from 35S promoter was not detected in total RNA and the W4 isolate does not encapsidate SsgRNA.

To analyze if the replication defective mutant RNAs transcribed from the 35S promoter were encapsidated by the CP provided *in trans* by the replicating wild-type virus, virions were purified from tissues co-infiltrated with mutant and wild-type SbDV genomes, and northern blot and RT-PCR were conducted on encapsidated RNAs. Northern blots on RNA extracted from virions purified from tissues co-infiltrated with ORF deletion mutants and wild-type virus showed the presence of wild-type gRNA in all combinations (Figure 5.6A). Mutant gRNAs were not visible on northern blots except for the gRNA of the Δ ORF5 mutant. Genomic RNA of the Δ ORF5 mutant was more abundant than the wild-type gRNA. This mutant also preferentially packaged its truncated LsgRNA (Figure 5.6A; lane 5). Surprisingly, the LsgRNA, which was not encapsidated by the wild-type virus, was preferentially encapsidated relative to wild-type gRNA in tissues co-infiltrated with the Δ ORF1 mutant and wild-type virus (Figure 5.6A; lane 1).

Because northern blots could not detect mutant gRNAs in samples co-infiltrated with Δ ORF mutants and wild-type virus, the virion gRNAs were analyzed by RT-PCR. The PCR products corresponding to the wild-type and mutants gRNAs were amplified, but to different levels. Co-infiltration of wild-type virus with Δ ORFs 1, 2, 3 and 4 mutants showed much greater amounts

of RT-PCR products from wild-type gRNA than the deletion mutant genomes. The amount of product from the Δ ORF2 gRNA was much less compared to the product from wild-type virus genome and was even less in the case of the Δ ORFs 1, 3 and 4 mutants (Figure 5.6B; lanes 1, 6, 10, and 15). In contrast, higher amounts of RT-PCR product corresponding to the gRNA of the Δ ORF5 mutant were observed in comparison to the amounts of products amplified from wild-type gRNA from co-infiltrated tissues (Figure 5.6B; lane 20). None of the amplification reactions without reverse transcription produced bands of the expected sizes, which excluded the possibility that the observed bands were derived from contaminating binary plasmids (Figure 5.6B; lanes 4, 8, 13, 18, and 23).

To test the role of RTD and 3' UTR sequences in the encapsidation of SsgRNA of SbDV, mutants of the W4 isolate were created by transferring these regions from CIIL2 to W4. *Nicotiana benthamiana* leaves infiltrated with RTP and 3' UTR replacement mutants of W4 were ELISA positive for SbDV. This indicated that the mutants replicated and packaged virions in infiltrated leaves. Northern blot analysis of the RNA content of sucrose gradient-purified virions showed that UTR replacement mutant of W4 encapsidated both gRNA and SsgRNA (Figure 5.7; lane 2), while the RTP replacement mutant packaged only gRNA (Figure 5.7; lane 1).

Requirement for replication of SbDV gRNA in packaging

To study if replication of SbDV RNAs is needed for their encapsidation in virions, these two steps in the viral life cycle had to be separated. For that, a replication deficient mutant was created by changing the amino acid sequences in the catalytic site of the replicase. Sequencing reactions and restriction enzyme digestions on replicase mutant confirmed the amino acid mutations (GDD to DAY) in the functional domain of the replicase enzyme in the mutant plasmid (Figure 5.8A). This mutant was not expected to replicate or synthesize subgenomic RNAs. Repeated attempts to detect replication by ELISA and northern blot on multiple infiltrated samples confirmed that the mutant was replication deficient.

In order to provide a CP, a 2990-bp PCR product corresponding to the LsgRNA region was synthesized and ligated into the binary vector pCZ14 downstream of a CaMV 35S promoter. RNA transcribed from the LsgRNA construct was not detected on northern blots and CP was not detected in ELISA indicating that either the construct wasn't functional or produced LsgRNA and CP at undetectable levels. Similarly, biotinylated probes did not detect either full-length gRNA or LsgRNA in tissues co-infiltrated with the replicase mutant and LsgRNA construct. Hence, it was not possible to study encapsidation of the replicase mutant RNA with a CP provided by non-replicating construct. As an alternative, *N. benthamiana* leaves were co-infiltrated with *Agrobacterium* harboring the replicase mutant and wild-type (W4) genomes to analyze if this mutant RNA would be packaged in presence of CP provided *in trans* by a replicating wild-type SbdV genome. Co-infiltration of the mutant and wild-type genomes resulted in local infection of SbdV that was evident from positive ELISA readings (Table 5.3) and detection of gRNA, LsgRNA and SsgRNA on northern blots of total RNA extracted from infiltrated leaves (Figure 5.8B). The packaged RNA content was analyzed by RT-PCR on RNAs extracted from purified virions as described for ORF deletion mutants.

Primers 2155F and Mut2155F were designed to specifically detect wild-type and mutant sequences, respectively, when used with primer 2565R in RT-PCR. As expected, primers 2155F and 2565R amplified 410-bp fragment from wild-type plasmid, but not from mutant plasmid template (Figure 5.8C; lanes 3 and 4). Conversely, primers Mut2155F and 2565R amplified the expected 410-bp fragment from mutant plasmid template but not from wild-type (Figure 5.8C; lanes 8 and 9). With the addition of reverse transcriptase, both combinations of primers amplified fragments of 410-bp from RNA extracted from purified virions (Figure 5.8C; lanes 1 and 6). Without reverse transcriptase, PCR products were not detected with either primer pair (Figure 5.8C; lanes 2 and 7). Thus, the presence of PCR products with both primer pairs in virion-derived RNA sample indicated packaging of replicase mutant genome in the SbdV virions.

DISCUSSION

Role of coding regions in SbDV replication

Deletion of coding regions in SbDV abolished replication except in the cases of Δ ORF3 and 5 mutants. In Δ ORF 1 and 2 mutants, neither gRNA nor sgRNAs were observed. The ORFs 1 and 2 encode replication-related proteins in luteoviruses and deletion of either of these ORFs results in non-replicating mutants. In addition to this, the product of ORF2, that codes for RdRp, is expressed only as a frameshift protein fused to ORF1 protein (P1) via low frequency (-1) ribosomal frameshift in the region of overlap (Paul *et al.*, 2001) between ORFs 1 and 2. Thus expression of P2 requires translation of ORF1. Hence, Δ ORF1 mutant lacks both P1 and P1P2 proteins and *cis*-acting sequences of ORF1, while Δ ORF2 mutant may produce a functional P1, but lacks P1P2 and *cis*-acting sequences of ORF2. Lack of replication of Δ ORF2 mutant suggests that even if P1 is produced, it is not functional for viral replication in the absence of P1P2 protein. Thus, similar to BWYV (Reutenauer *et al.*, 1993) and BYDV (Mohan *et al.*, 1995), SbDV replication requires *cis*-acting sequences of both ORF1 and ORF2 and proteins encoded by them.

Replication of viral RNAs in plants infiltrated with the Δ ORF3 mutant indicated that, in SbDV, CP or ORF3 sequences are not needed for the translation of the viral genome and replication of gRNA and sgRNAs. This observation is in accordance with the reports in BWYV (Reutenauer *et al.* 1993) and in BYDV (Mohan *et al.*, 1995). But contradictory to their reports and the report by Sacher and Ahlquist (1989), there was no reduction in replication efficiency of either gRNA and sgRNA in this mutant compared to the wild-type (Figure 5.4B). Thus CP or CP nt sequences do not have major regulatory roles in gRNA and sgRNA synthesis of SbDV.

Since ORF4 is contained within ORF3, deletion of Δ ORF3 or 4 mutants would not be detected in ELISA, which recognizes the viral coat protein. Because the Δ ORF3 mutant replicated, the replication of ORF4 mutant was expected, but was not observed in the present study. The Δ ORF4 mutant by design incorporated 16 nt from the 5' end of ORF3 including the start codon,

MluI restriction site sequences (ACGCGT), and 17 nt of the extreme 3' end of ORF3. It is possible that in this mutant, the RTD was translated from the start codon of ORF3. The protein would have the entire amino acid sequence of RTD with amino terminus made up of 12 amino acids from ORF3 and *MluI* restriction site sequences. In wild-type virus, RTP is translated only as a fusion product of CP. Because this is the only difference between the Δ ORF3 and Δ ORF4 mutants, the lack of replication of Δ ORF4 mutant might be due to the inhibition of replication in the presence of this novel viral protein.

The Δ ORF5 mutant transcribed SsgRNA, but the presence of truncated LsgRNA was not clear due to the smear in the lane. Since SsgRNA was synthesized in this mutant, it is assumed that ORF5 sequences are not needed for translation of the viral genome, synthesis of minus-strand RNA and subsequent replication of sgRNAs from minus-strand RNA. However, deletion of ORF5 greatly reduced the replication of gRNA. It is possible that *cis*-acting signals in ORF5 might have a regulatory role in synthesis of gRNA. The present study indicated that ORFs 1 and 2 are essential for SbDV replication. Although deletion of the extreme 3' end of ORF5 along with approximately 20 nt from the 3' UTR in BYDV abolished replication, much of the sequences of ORF5 and RTP were dispensable for replication in BYDV (Filichkin *et al.*, 1994; Mohan *et al.*, 1995). A report from another luteovirus, BWYV, also revealed that no *cis*-acting sequences necessary for the replication of gRNA or sgRNA were present in ORFs 3, 4 and 5 and the proteins encoded by these ORFs were not necessary for viral replication (Reutenauer *et al.*, 1993). Compared to studies with BWYV and BYDV, the entire ORF5 was deleted in the present investigation. Sequential deletion of parts of ORF5 might reveal the minimum sequence necessary for efficient genome replication of SbDV.

Role of long-distance interactions between stem-loop structures in the 5' and 3' UTRs in SbDV replication

The nt substitutions in the 5' and 3' UTRs destroyed the ability of the virus to replicate, probably through the loss of interaction between the 5'- and 3'-stem-loop structures. The RNA-RNA interactions between stem-loop structures are important for translation and replication of viral genomes (Wang *et al.*, 1999; Miller and White, 2006). Co-infiltration of 5'- and 3'-UTR

mutants that had wild-type stem-loops in their 3' and 5' UTRs, respectively enhanced the relative accumulation of LsgRNA compared to gRNA and SsgRNA (Figure 5.5; lane 7). This showed that the mutated SbDV genomes were translated and replicated in the co-infiltrated tissues. Since these mutated stem-loops were in two different RNAs, the restoration of low-level viral replication suggested that the two wild-type and or mutant stem-loops might have interacted *in trans*. Another possibility is that, presence of these two RNAs in co-infiltrated cells might have led to recombination between them resulting in the generation of some wild-type RNA sequences.

The 5'-3' double mutant in which mutation in 5' UTR was complemented by a corresponding nt change in the 3' UTR, infiltrated tissues showed only the presence of gRNA (Figure 5.5; lane 4). This indicated that the mutated stem-loops restored the long-distance interaction in this mutant leading to the replication of gRNA. But the nt substitutions in these stem-loops might have altered the stability or secondary structures of the stem-loops and thus blocked interactions needed for transcription of sgRNAs. The DAS-ELISA was negative for infiltrated leaves of all these mutants probably because, the restored interaction and thus replication of gRNA (that is encapsidated in W4) was not to the level of wild-type.

In all non-replicating SbDV mutants, the mutant gRNAs transcribed from CaMV 35S promoter were not detected on northern blots of total RNA from leaves when they were infiltrated alone and in combination with the wild-type virus, probably due to lower level of transcription rate that is difficult to be detected by the biotinylated probe. It indicated that the mutant RNAs except ORF3 (Figure 5.4C; lane 3) did not replicate even in the presence of the helper virus genome. Hence, local infections observed in leaves co-infiltrated with non-replicating mutants and wild-type virus likely resulted from the wild-type genome.

Involvement of coding sequences in SbDV encapsidation

Viral CP was not detected by DAS-ELISA of tissues infiltrated with any of the SbDV mutants. This indicated that these mutants were not assembled into particles to a detectable level. This is expected because of the lack of detectable replication (except Δ ORF3) and thus absence of CP in

all mutants. Because these mutants were replication deficient, failed to form detectable levels of virions, no information could be gained about the involvement of these *cis*-acting deletions and nt mutations or proteins encoded by them in encapsidation of SbdV. So, packaging of ORF deletion mutants was analyzed by co-infiltrating the mutants with the replicating wild-type virus.

Virions from the co-infiltrations were purified and RNA content was analyzed through northern blots and RT-PCR. The preferential packaging of mutant gRNA and LsgRNA that were devoid of ORF5 was observed in combination of Δ ORF5 mutant with wild-type virus (Figure 5.6A; lane 5 and 5.6B; lane 20). The gRNA of Δ ORF5 mutant was not detected in northern blot of total RNA from co-infiltrated leaves. But this non-replicating, low abundance RNA transcribed from the CaMV 35S promoter was packaged preferentially in comparison to the replicating and much more abundant wild-type gRNA. Similarly, the truncated LsgRNA that was not detected clearly in total RNA samples, was also encapsidated by the CP provided by the wild-type virus. By removing ORF5, a signal that has a negative regulatory effect on the encapsidation of gRNA might have been removed, leading to the preferential packaging of the mutant gRNA compared to the highly abundant wild-type gRNA. This was not observed in other mutants possibly due to the presence of ORF5 sequences, although mutant RNAs were packaged at a low level according to PCR result.

The co-infiltration of Δ ORF1 with wild-type helper virus resulted in the preferential encapsidation of LsgRNA that was not packaged in the wild-type virus (Figure 5.6A; lane 1). From the experiments in Chapter 4, it was evident that LsgRNA is protected and possibly sequestered at the top of sucrose gradient. The packaging of this RNA suggested that, like gRNA, LsgRNA also possesses a packaging signal that interacts with the capsid protein. The LsgRNA is transcribed from the 3' region of ORF2 of the minus-strand RNA and thus it contains sequences of ORF5, but not ORF1. Incorporation of LsgRNA into virions in this mutant plus wild-type combination indicated that the loss of a *trans*-acting signal from this mutant RNA relieved the blockage of LsgRNA encapsidation present in the helper virus. These results indicated existence of three possible packaging signals in SbdV; one in ORF5 that negatively regulates gRNA and LsgRNA encapsidation, a second signal possibly in the 5' UTR of the

genome that favors the gRNA encapsidation and a third *trans*-acting signal in ORF1 that blocks the encapsidation of LsgRNA.

The RT-PCR revealed encapsidation of Δ ORFs 1, 2, 3 and 4 mutant RNAs but at levels similar to their accumulation in co-infiltrated tissues (Figure 5.6B). In SbDV, these coding regions probably are not involved in encapsidation of gRNA. The present study clearly indicated that ORF5 sequences are not needed for SbDV gRNA encapsidation. In other viruses like *Beet necrotic yellow vein virus* (BNYVV), RTP is necessary for efficient virus assembly (Schmitt, *et al.*, 1992), in luteoviruses like BYDV (Filichkin *et al.*, 1994) and BWYV (Reutenauer *et al.* 1993), mutants lacking RTP or ORF5 sequences were shown to form virus particles.

Encapsidation signal for SbDV SsgRNA

The encapsidation of SsgRNA in the 3' UTR replacement mutant of W4 (Figure 5.7; lane 2) suggested that the signal for the differential encapsidation of this small RNA is in the SsgRNA and not in the RTD. Replacing the RTD from W4 with that from CIIL2 did not change the packaged RNA content of W4. The 3' UTR of SbDV is 600 nt long. Sequential deletion of small regions of sequences in this region or point mutations either in CIIL2 or W4 isolates at positions of nt differences in 3' UTR or SsgRNA sequences could be used to identify the minimum packaging signal for SsgRNA in SbDV.

Encapsidation of replication deficient mutant RNAs in SbDV

In the present study, the replicase mutant created by mutagenesis of GDD sequences was not infectious as indicated by DAS-ELISA and northern blots. The amino acid mutations in the catalytic core of replicase enzyme were designed to destroy the functionality of the enzyme and prevent replication of this mutant RNA. The RT-PCR on virion-derived RNAs extracted from tissues co-infiltrated with mutant and wild-type genome showed the presence of amplified products that were synthesized from both the wild and the mutated genomes (Figure 5.8C). This confirmed the packaging of replicase mutant RNA with the CP provided *in trans* by the co-inoculated wild-type helper virus. In some viruses, packaging is coupled to replication, which is

thought to facilitate the efficiency and specificity of encapsidation by sequestering this process to the sites of viral replication (Nugent *et al.*, 1999; Khromykh *et al.*, 2001; Venter *et al.*, 2005). This also ensures that the RNAs assembled into virions are replication competent. When replication and packaging are coupled, non-replicating sgRNAs were not encapsidated by CP provided by the replicating poliovirus genome (Nugent *et al.*, 1999).

In addition to the replicase mutant, the replication-deficient ORF-deletion mutants were also packaged by SbdV CP provided by the wild-type helper virus, which suggested that filtering of replication-competent RNAs for encapsidation does not exist in SbdV and that packaging in SbdV is replication independent. Similarly in TYMV (Cho and Dreher, 2006), a non-replicating gRNA with a mutation in the polymerase domain was efficiently encapsidated by CP provided *in trans*. In BMV, although packaging of gRNAs is independent of replication, the sgRNA encapsidation was coupled to replication (Annamalai and Rao, 2006). In these two studies the CPs were provided by a non-replicating RNA. In FHV, a special type of coupling between replication and encapsidation was observed in which viral RNAs were packaged by the CP provided by a replicating RNA but not with CP transiently expressed from a non-replicating RNA (Venter *et al.*, 2005). In present study since the CP is provided by a replicating wild-type RNA, any role of replication complex acting *in trans* for the encapsidation of the mutant RNAs is not ruled out.

REFERENCES

- Annamalai, P. and Rao, A.L.N. 2005. Replication-independent expression of genome components and capsid protein of brome mosaic virus in planta: a functional role for viral replicase in RNA packaging. *Virology* 338:96-111.
- Annamalai, P. and Rao, A.L.N. 2006. Packaging of BMV subgenomic RNA is functionally coupled to replication dependent transcription and translation of coat protein. *J. Virology* 80:10096-10108.
- Cho, T.J. and Dreher, T.W. 2006. Encapsidation of genomic but not subgenomic Turnip yellow mosaic virus RNA by coat protein provided in trans. *Virology* 356:126-135.
- Choi, Y.G., Dreher, T.W. and Rao, A.L.N. 2002. tRNA elements mediate the assembly of an icosahedral RNA virus. *Proc. Natl. Acad. Sci. USA* 99:655-660.

- Dreher, T.W. 1999. Functions of the 3' un-translated regions of positive strand RNA viral genomes. *Annu. Rev. Phytopathol.* 37:151-174.
- Filichkin, S.A., Lister, R.M., McGrath, P.F. and Young M.J. 1994. *In vivo* expression and mutational analysis of the barley yellow dwarf virus readthrough gene. *Virology* 205:290-299.
- Fox, J.M. 1994. RNA-protein interactions in icosahedral virus assembly. *Semin. Virol.* 5:51-60.
- French, R. and Ahlquist, P. 1987. Intercistronic as well as terminal sequences are required for efficient amplification of brome mosaic virus RNA3. *J. Virol.* 61:1457-1465.
- Guo, L., Allen, E.M. and Miller, W.A. 2001. Base-pairing between un-translated regions facilitates translation of uncapped, non-polyadenylated viral RNA. *Mol. Cell* 7:1103-1109.
- Ishikawa, M., Meshi, T., Ohno, T. and Okada, Y. 1991. Specific cessation of minus strand RNA accumulation at an early stage of tobacco mosaic virus infection. *J. Virol.* 65:861-68.
- Khromykh, A.A., Varnavski, A.N., Sedlak, P.L. and Westaway, E.G. 2001. Coupling between replication and packaging of flavivirus RNA: evidence derived from the use of DNA-based full-length cDNA clones of kunjin virus. *J. Virol.* 75:4633-4640.
- Lokesh, G.L., Gowri, T.D., Satheshkumar, P.S., Murthy, M.R. and Savithri, H.S. 2002. A molecular switch in the capsid protein controls the particle polymorphism in an icosahedral virus. *Virology* 292:211-223.
- Marquet, R., Isel, C., Ehresmann, C. and Ehresmann, B. 1995. tRNAs as primer of reverse transcriptases. *Biochimie* 77:113-124.
- Miller, W.A. and White, K.A. 2006. Long distance RNA-RNA interactions in plant virus gene expression and replication. *Annu. Rev. Phytopathol.* 44:19.1-19.21.
- Mohan, B.R., Dinesh-Kumar, S.P. and Miller, W.A. 1995. Genes and cis-acting sequences involved in replication of barley yellow dwarf virus-PAV RNA. *Virology* 212:186-195.
- Nugent, C.I., Johnson, K.L., Sarnow, P. and Kirkegaard, K. 1999. Functional coupling between replication and packaging of poliovirus replicon RNA. *J. Virol.* 73:427-435.
- Ogawa, T., Watanabe, Y. and Okada, Y. 1992. *cis*-acting elements for *in trans* complementation of replication-defective mutant of tobacco mosaic virus. *Virology* 191:454-458.
- Paul, C.P., Barry, J.K., Dinesh-Kumar, S.P., Brault, V. and Miller, W.A. 2001. A sequence required for -1 ribosomal frameshifting located four kilobases downstream of the frameshift site. *J. Mol. Biol.* 310:987-999.

- Pogue, G.P., Marsh, L.E. and Hall, T.C. 1990. Point mutations in the ICR2 motif of brome mosaic virus RNAs debilitate (+)-strand replication. *Virology* 178:152-160.
- Prufer, D., Wipf-Scheibel, C., Richards, K., Guilley, H., Lecoq, H. and Jonard, G. 1995. Synthesis of a full-length infectious cDNA clone of cucurbit aphid-borne yellows virus and its use in gene exchange experiments with structural proteins from other luteoviruses. *Virology* 214:150-158.
- Qu, F. and Morris, T.J. 1997. Encapsidation of turnip crinkle virus is defined by a specific packaging signal and RNA size. *J. Virol.* 71:1428-1435.
- Rao, A.L.N. 2006. Genome packaging by spherical plant RNA viruses. *Annu. Rev. Phytopathol.* 44:61-87.
- Reutenauer, A., Ziegler-Graff, V., Lot, H., Scheidecker, D., Guilley, H., Richards, K. and Jonard, G. 1993. Identification of beet western yellows luteovirus genes implicated in viral replication and particle morphogenesis. *Virology* 195:692-699.
- Rixon, F. 1993. Structure and assembly of herpesviruses. *Semin. Virol.* 4:135-144.
- Sacher, R. and Ahlquist, P. 1989. Effects of deletions in the N-terminal basic arm of brome mosaic virus coat protein on RNA packaging and systemic infection. *J. Virol.* 63:4545-4552.
- Sambrook, J. and Russel, D.W. 2001. Molecular cloning- A laboratory manual, 3rd edition, Cold Spring harbor lab press, NY. P. 999.
- Schmitt, C., Balmori, E., Jonard, G., Richards, K.E. and Guilley, H. 1992. *In vitro* mutagenesis of biologically active transcripts of beet necrotic yellow vein virus RNA 2: Evidence that a domain of the 75-kDa readthrough protein is important for efficient virus assembly. *Proc. Nati. Acad. Sci.* 89:5715-5719.
- Song, C. and Simon, A.E. 1995. Requirement of a 3'-terminal stem-loop in *in vitro* transcription by an RNA-dependent RNA polymerase. *J. Mol. Biol.* 254:6-14.
- Venter, P.A, Krishna, N.K. and Schneemann, A. 2005. Capsid protein synthesis from replicating RNA directs specific packaging of the genome of a multipartite, positive-strand RNA virus. *J. Virol.* 79:6239-6248.
- Vlot, A.C., Neeleman, L., Linthorst, H.J. and Bol, J.F. 2001. Role of the 3' un-translated regions of alfalfa mosaic virus RNAs in the formation of a transiently expressed replicase in plants and in the assembly of virions. *J. Virol.* 75:6440-6449.
- Vriend, G., Verduin, B.J. and Hemminga, M.A. 1986. Role of the N-terminal part of the coat protein in the assembly of cowpea chlorotic mottle virus. A 500 MHz proton nuclear magnetic resonance study and structural calculations. *J. Mol. Biol.* 191:453-460.

- Wang, J., Carpenter, C.D. and Simon, A.E. 1999. Minimal sequence and structural requirements of a subgenomic RNA promoter for turnip crinkle virus. *Virology* 253:327-336.
- Zhao, X., Fox, J.M., Olson, N.H., Baker, T.S. and Young, M.J. 1995. *In vitro* assembly of cowpea chlorotic mottle virus from coat protein expressed in *Escherichia coli* and *in vitro*-transcribed viral cDNA. *Virology* 207:486-494.

Table 5.1. Primer sequences and polymerase chain reaction (PCR) conditions used for the construction of open reading frame deletion (Δ ORF) mutants of *Soybean dwarf virus*.

ORF mutant	PCR	Primers	Primer sequences	PCR cycles
Δ ORF1	PCR I	<i>Sal</i> I126R <i>CaMV</i> <i>Hin</i> dIII	^a 5'-GAGAGTCGACAACCTAACAATAACACTAGAGATTC-3' 5'-GAGAGAAAGCTTAGTCGGGAAACCTGTCGTGCC-3'	3 cycles of 94°C-30 s, 50°C-30 s and 72°C-1 min followed by 26 cycles of 94°C-30 s, 60°C-30 s and 72°C-1 min.
	PCR II	<i>Sal</i> I1234F 2395R	5'-GAGAGTCGACGTTTTGAATCCCCGTTTTCT-3' 5'-GCCATGGAAATGAGGGAATG-3'	3 cycles of 94°C-30 s, 50°C-30 s, and 72°C-1 min 20 s followed by 26 cycles of 94°C-30 s, 57°C-30 s and 72°C-1 min 20 s.
Δ ORF2	PCR I	1F <i>Xba</i> I1176R	5'-AGTAAAGTTGACACCTTTACAGAAGTG-3' 5'-TCTCTCTAGACACGCCCAACTCATGC-3'	3 cycles of 94°C-30 s, 51°C-30 s and 72°C-1 min 20 s followed by 26 cycles of 94°C-30 s, 60°C-30 s and 72°C-1 min 20 s.
	PCR II	<i>Xba</i> I2708F 4786R	5'-TCTCTCTAGAAACCCCGCGGCGT-3' 5'-CCYCGGGAGACAAAAGTGT-3'	3 cycles of 94°C-30 s, 52°C-30 s and 72°C-2 min followed by 26 cycles of 94°C-30 s, 52°C-30 s and 72°C-2 min.
Δ ORF3	PCR I	1231F <i>Mlu</i> I <i>Apa</i> I3018R	5'-GCTCTGCTCCGACTCTGGTTTTGA-3' 5'-ATTATACGCGTGGGCCCATTCGTTGATGATTCCTC-3'	3 cycles of 94°C-30 s, 45°C-30 s and 72°C-1 min 50 s followed by 26 cycles of 94°C-30 s, 61°C-30 s and 72°C-1 min 50 s.
	PCR II	<i>Mlu</i> I3622F 4786R	5'-ATTAACGCGTGGAGAACCGGGCCGAA-3' 5'-CCYCGGGAGACAAAAGTGT-3'	3 cycles of 94°C-30 s, 56°C-30 s and 72°C-1 min 10 s followed by 26 cycles of 94°C-30 s, 52°C-30 s and 72°C-1 min 10 s.
Δ ORF4	PCR I	1231F <i>Mlu</i> I <i>Apa</i> I3034R	5'-GCTCTGCTCCGACTCTGGTTTTGA-3' 5'-ATTAACGCGTGGGCCCTGCTAACCGCGACCATAT-3'	3 cycles of 94°C-30 s, 52°C-30 s and 72°C-1 min 50 s followed by 26 cycles of 94°C-30 s, 61°C-30 s and 72°C-1 min 50 s.
	PCR II	<i>Mlu</i> I3605F 4786R	5'-ATTAACGCGTCTCAGAATCCCAAATAGG-3' 5'-CCYCGGGAGACAAAAGTGT-3'	3 cycles of 94°C-30 s, 56°C-30 s and 72°C-1 min 10 s followed by 26 cycles of 94°C-30 s, 52°C-30 s and 72°C-1 min 10 s.
Δ ORF5	PCR I	1231F <i>Apa</i> I3621R	5'-GCTCTGCTCCGACTCTGGTTTTGA-3' 5'-ATTAGGGCCCCTATTTGGGATTCTGAGTTA-3'	3 cycles of 94°C-30 s, 46°C-30 s and 72°C-2 min 30 s followed by 26 cycles of 94°C-30 s, 61°C-30 s and 72°C-2 min 30 s.
	PCR II	<i>Apa</i> I5092F 5688R	5'-ATTAGGGCCCCTTGCACCAATATAGAA-3' 5'-GAGAGACCCGGGCGAGGTGGACCTGATGGC-3'	3 cycles of 94°C-30 s, 43°C-30 s and 72°C-40 s followed by 26 cycles of 94°C-30 s, 60°C-30 s and 72°C-40 s.

^a Restriction sites of the enzymes are either underlined or italicized.

Table 5.2. Primer sequences and polymerase chain reaction (PCR) conditions used to detect encapsidation of *Soybean dwarf virus* (SbDV) RNAs extracted from virions purified from *Nicotiana benthamiana* tissues co-infiltrated with wild-type virus and mutants of SbDV.

Mutant-wild combination	Primers	Primer sequences	PCR cycles
ΔORF1+W4	1F 1931R	5'-AGTAAAGTTGACACCTTTACAGAAGTG-3' 5'-CCGTTATAGATTGAGTGCTCCCAT-3'	40 cycles of 94°C-30 s, 56°C-30 s and 72°C-2 min 30 s.
ΔORF2+W4	680F 2961R	5'-GGTTCAACACTCTGCCCAATAGAATGA-3' 5'-ATTCTTTGAAATTTTTAGGTAAACAAAGTAAATTGC-3'	40 cycles of 94°C-30 s, 56°C-30 s and 72°C-2 min 30 s.
ΔORF3+W4	2563F 3742R	5'-AGGACAAACTCGGGCTCAGGAAAG-3' 5'-AGTGTTGACAGTGTACCGGT-3'	40 cycles of 94°C-30 s, 53°C-20 s and 72°C-1 min 15 s.
ΔORF4+W4	2563F 3742R	5'-AGGACAAACTCGGGCTCAGGAAAG-3' 5'-AGTGTTGACAGTGTACCGGT-3'	40 cycles of 94°C-30 s, 53°C-20 s and 72°C-1 min 15 s.
ΔORF5+W4	3248F 5234R	5'-GGA ACTATCACTTTCGGGCCG-3' 5'-GGATATGCAACCGAAAGTGATA-3'	40 cycles of 94°C-30 s, 52°C-30 s and 72°C-2 min 10 s.
Replicase mutant+W4	2155F 2155MutF 2565R	5'-AACTCTGCAATAACGGCGATGAT-3' 5'-AACTCTGCAATAACGACGCGTAT-3' 5'-TTTCCTGAGCCCCGAGTTTGTC-3'	40 cycles of 94°C-30 s, 56°C-20 s and 72°C-30 s.

Table 5.3. Detection of *Soybean dwarf virus* (SbDV) infections by DAS-ELISA in *Nicotiana benthamiana* leaves agroinfiltrated with SbDV mutants.

Mutant	No. of leaves infected	No. of leaves Infected in mutant+ wild
Δ ORF1	0/9	14/17
Δ ORF2	0/3	6/9
Δ ORF3	0/29	6/6
Δ ORF4	0/6	6/6
Δ ORF5	0/23	8/12
3' UTR	0/11	3/6
5' UTR	0/10	3/5
3'+ 5' UTRs	0/13	^a ND
3'- 5' UTR double mutant	0/10	ND
LsgRNA clone	0/11	ND
Replicase	0/3	19/23
LsgRNA clone + Replicase	0/7	ND
RTP replacement	8/8	ND
UTR replacement	8/8	ND

^a ND- Not determined

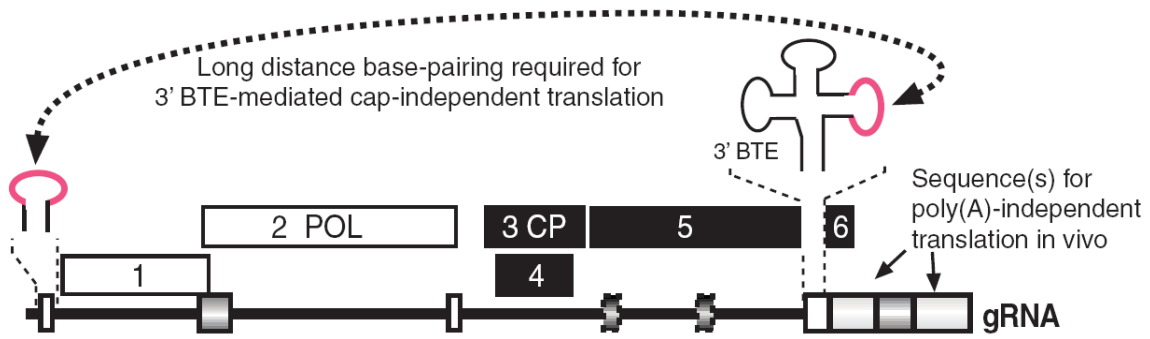

Figure 5.1. Long-distance interactions in the expression of *Barley yellow dwarf virus* (BYDV) translation and replication (Miller and White, 2006). The nucleotide sequence of the *Soybean dwarf virus* genome RNA (gRNA) is very closely related to that of BYDV and contains a stem-loop structure similar to the BYDV translation enhancer (BTE) in 3' un-translated region (UTR) and an interacting stem-loop in its 5' UTR that could be required for selective packaging of gRNA.

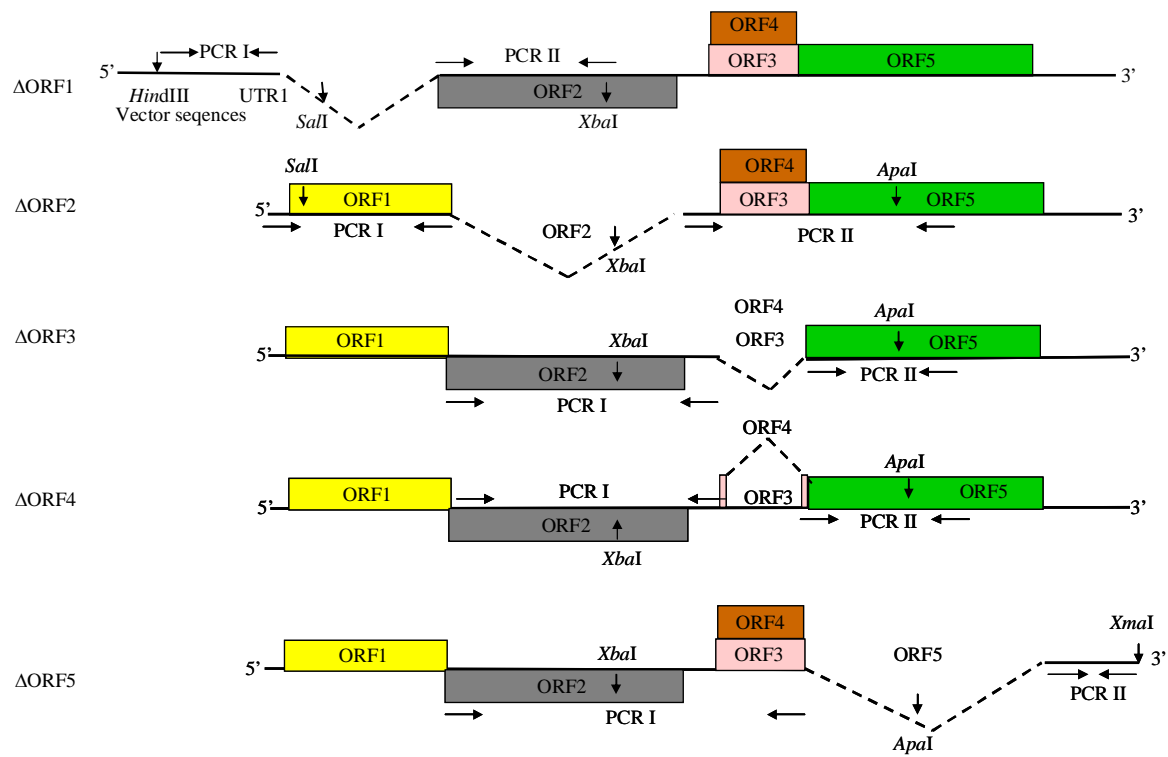

Figure 5.2. Diagrammatic representation of construction of open reading frame deletion (Δ ORF) mutants in full-length clones of *Soybean dwarf virus* isolate W4. To delete a particular ORF, two polymerase chain reaction (PCR) products were amplified and cloned sequentially into pCZ14W4 devoid of PCR I and PCR II. The restriction sites for the enzymes used for the construction of the mutants and regions amplified in PCR I and PCR II are indicated.

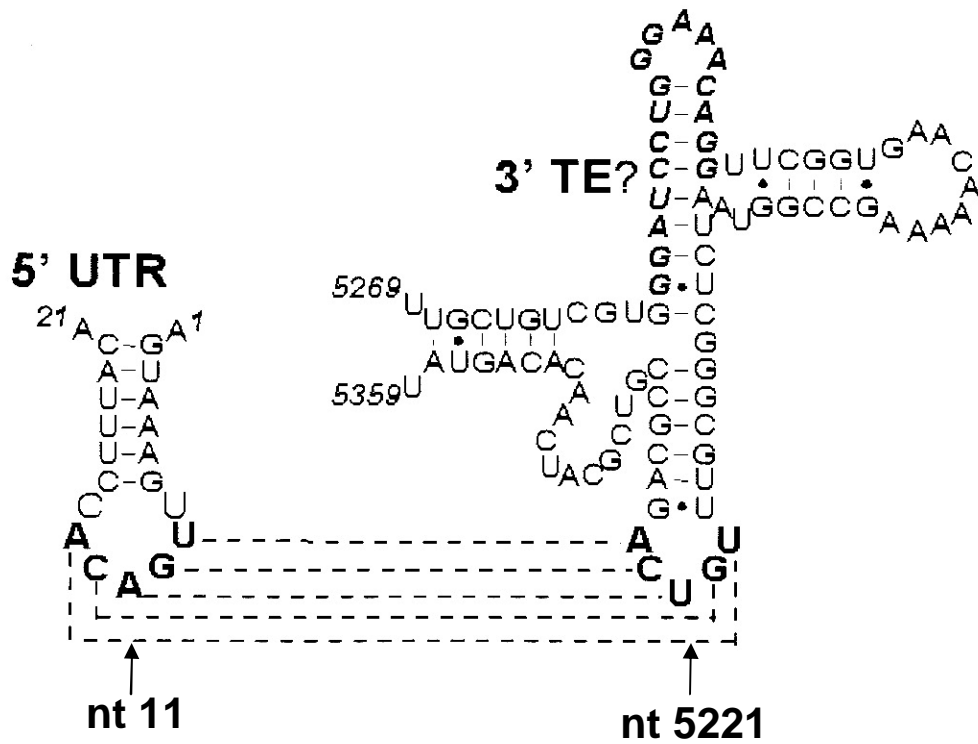

Figure 5.3. The stem-loop structures in the 5'-and 3'-untranslated regions (UTRs) of *Soybean dwarf virus* predicted to be involved in long-distance interaction (Guo *et al.*, 2001). For the present study, these interacting nucleotide (nt) sequences were identified at positions 9 - 13 and 5219 - 5223 in the 5' and 3' UTRs respectively, in W4.

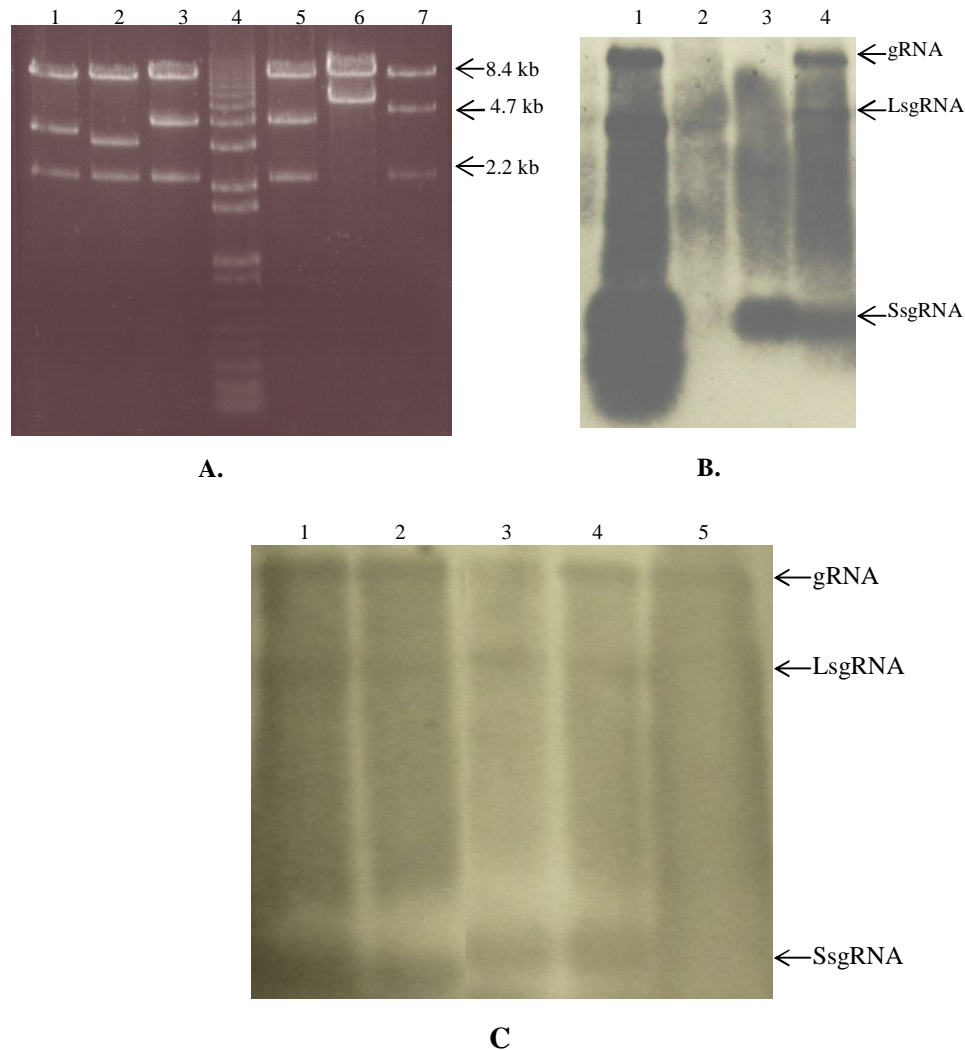

Figure 5.4. Effect of open reading frame (ORF) deletions on replication of *Soybean dwarf virus* (SbDV). **(A)** *EcoRI-HindIII* digestion of pCZ14 containing Δ ORF mutants. Lanes 1-7: Δ ORF1, Δ ORF2, Δ ORF3, 1-kb plus DNA ladder, Δ ORF4, Δ ORF5 and wild-type W4. The restriction fragment 8.4 kb was present in all plasmids. The 2.2-kb fragment of *EcoRI* was present in all plasmids except Δ ORF5, which removed a *EcoRI* site, leading to a second restriction fragment of 5.37 kb. The size of the third fragment in Δ ORFs 1, 2, 3, and 4 was 3.6 kb, 3.2 kb, 4.1 kb and 4.13 kb, respectively. **(B)** Northern blot on total RNA extracted from *Nicotiana benthamiana* infiltrated with Δ ORFs 3, 4, and 5 mutants. Lanes 1-4: Δ ORF3, Δ ORF4, Δ ORF5, and CIAGt2 infected soybean. Mutants devoid of coat protein encoding ORF3 replicated in *N. benthamiana* tissues. Lane 1 shows replication of large subgenomic RNA (LsgRNA) in Δ ORF3 mutant, which was smaller than the LsgRNA present in positive control (Lane 4). **(C)** Northern blot on total RNAs extracted from *N. benthamiana* agroinfiltrated with combinations of wild-type and Δ ORF mutants. The RNAs were hybridized with RNA probe *in vitro* transcribed from the region between 5406 - 5709 nucleotides on minus-strand. Lanes 1-5: Δ ORF1+wild, Δ ORF2+wild, Δ ORF3+wild, Δ ORF4+wild, and Δ ORF5+wild. The migrations of SbDV genomic RNA (gRNA), LsgRNA and small subgenomic RNA (SsgRNA) are indicated.

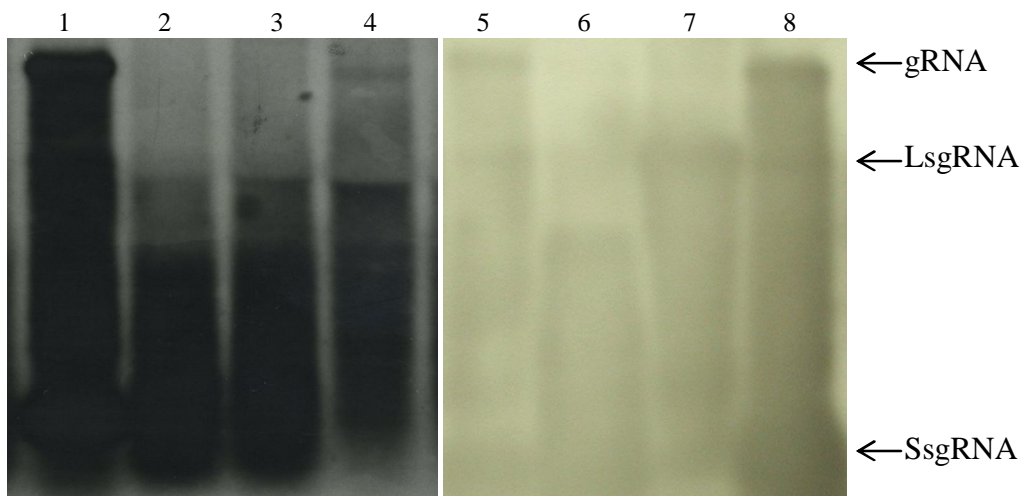

Figure 5.5. Northern blots on total RNAs extracted from *Nicotiana benthamiana* agroinfiltrated with untranslated region (UTR) mutants of *Soybean dwarf virus* (SbDV). Lane 1: wild-type, Lane 2: 5' UTR mutant, Lane 3: 3' UTR mutant, Lane 4: 5'-3' UTR double mutant, Lane 5: 3' UTR mutant+wild, Lane 6: CI-Agt2-infected soybean, Lane 7: 5' UTR mutant+3' UTR mutant, and Lane 8: 5' UTR mutant+wild. The migrations of SbDV genomic RNA (gRNA), large subgenomic RNA (LsgRNA) and small subgenomic RNA (SsgRNA) are indicated.

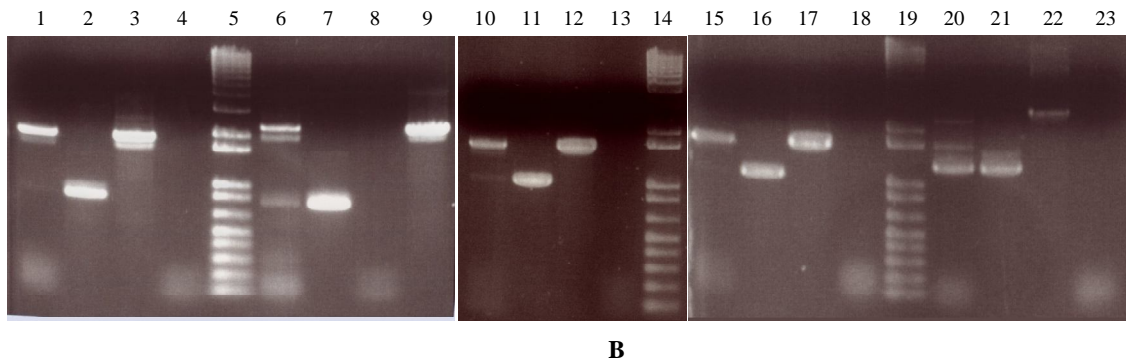
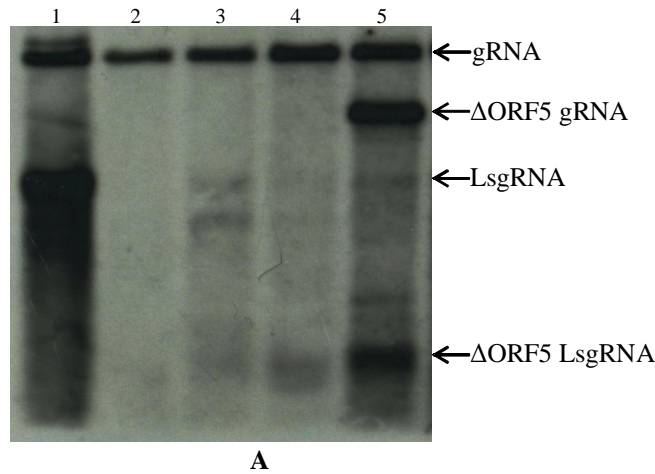

Figure 5.6. Effects of open reading frame deletion (Δ ORF) mutations on the trans-encapsulation of mutant *Soybean dwarf virus* (SbDV) RNAs. **(A)** Northern blot on the packaged RNA content of SbDV virions in *Nicotiana benthamiana* infiltrated with mutant and wild-type viruses. Virions were purified by sucrose-gradient centrifugation from agroinfiltrated tissues and RNA content of the virus peak was analyzed by northern blot. Lanes 1-5: Δ ORF1+wild, Δ ORF2+wild, Δ ORF3+wild, Δ ORF4+wild, and Δ ORF5+wild. Preferential encapsidation of large subgenomic RNA (LsgRNA) and mutant genomic RNA (gRNA) was observed in Δ ORF1 and Δ ORF5 mutants respectively. The migrations of SbDV wild-type gRNA and LsgRNA and Δ ORF5 genomic RNA (Δ ORF5 gRNA) and large subgenomic RNA (Δ ORF5 LsgRNA) are indicated.

(B) Reverse transcription polymerase chain reactions (RT-PCRs) on packaged RNAs extracted from virions of mutant-wild co-infiltrated *N. benthamiana* tissues. Virion RNAs were extracted and subjected to PCR with or without reverse transcriptase (RT). The RT-PCRs were carried out with the primer pairs described in Table 5.2. Lanes 1-4: Δ ORF1+wild cDNA with RT, Δ ORF1 plasmid DNA, wild-type plasmid DNA, and Δ ORF1+wild RNA without RT, Lanes 6-13: Δ ORF2+wild cDNA with RT, Δ ORF2 plasmid DNA, Δ ORF2+wild RNA without RT, wild-type plasmid DNA, Δ ORF3+wild RNA with RT, Δ ORF3 plasmid DNA, wild-type plasmid DNA, and Δ ORF3+wild RNA without RT, Lanes 15-18: Δ ORF4+wild RNA with RT, Δ ORF4 plasmid DNA, wild-type plasmid DNA, and Δ ORF1+wild RNA without RT, Lanes 20-23: Δ ORF5+wild RNA with RT, Δ ORF5 plasmid DNA, wild-type plasmid DNA, and Δ ORF5+wild RNA without RT, Lanes 5, 14 and 19: 1-kb plus DNA ladder.

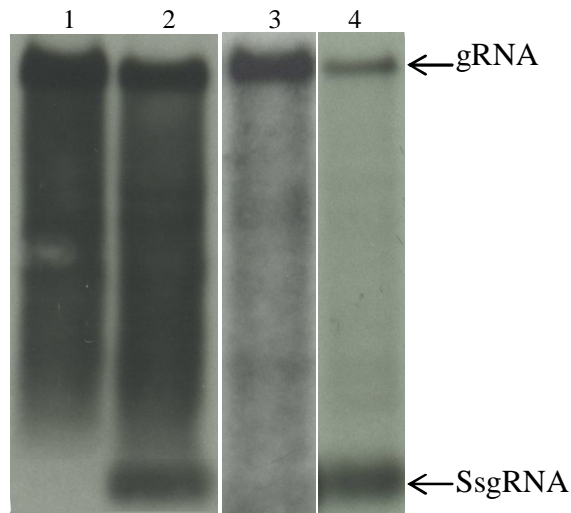

Figure 5.7. Effect of replacement of readthrough domain and 3' untranslated region (UTR) sequences of *Soybean dwarf virus* (SbDV) isolate W4 with that of CIIL2 isolate on encapsidation of small subgenomic RNA (SsgRNA). Lane 1: RTP replacement mutant, Lane 2: UTR replacement mutant, Lane 3: Encapsidated RNA of W4, Lane 4: Encapsidated RNA of CIIL2. The replacement of 3' UTR resulted in encapsidation of SsgRNA in W4 virions. The migrations of SbDV genomic RNA (gRNA) and SsgRNA are indicated.

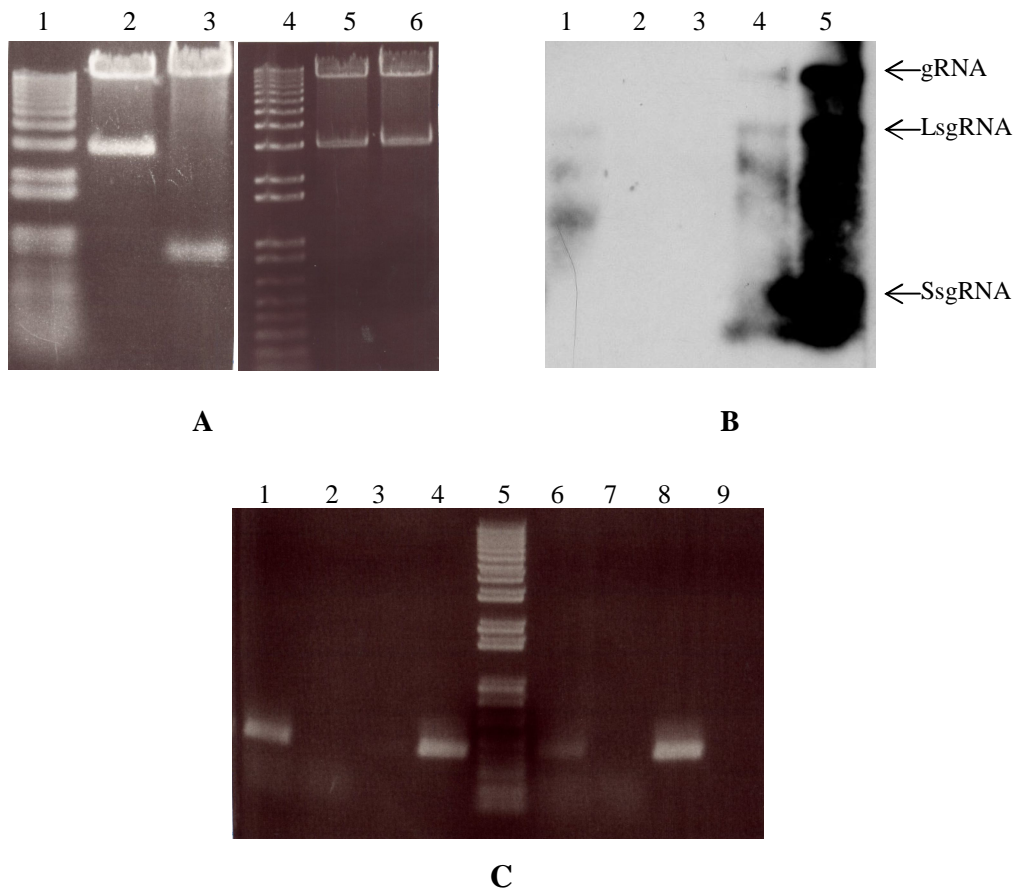

Figure 5.8. Effects of mutations in the functional domain of replicase enzyme on replication and encapsidation of *Soybean dwarf virus* (SbDV) RNAs. **(A)** Digestion of replicase mutant plasmid with restriction enzymes. The size of the restriction fragments in digestion with *Xba*I and *Apa*I and *Xba*I and *Mlu*I enzymes, and the presence of restriction site for *Mlu*I confirmed the insertion of mutated PCR III product. The digestion of large subgenomic RNA (LsgRNA) construct with *Xba*I and *Xma*I enzymes verified the insertion of 2990-bp PCR product in pCZ14 binary vector. Lanes 1 and 4: 1-kb plus DNA ladder, Lane 2: replicase mutant digested with *Xba*I and *Apa*I, Lane 3: replicase mutant digested with *Xba*I and *Mlu*I, Lanes 5 and 6: LsgRNA clone digested with *Xba*I and *Xma*I. **(B)** Northern blot on total RNAs extracted from *Nicotiana benthamiana* agroinfiltrated with replicase mutant alone and in combination with LsgRNA construct and with wild-type helper virus. All three wild-type RNAs are present when replicase mutant co-infiltrated with the helper virus. Lanes 1-5: replicase mutant, LsgRNA construct, replicase mutant+LsgRNA construct, replicase mutant+wild-type virus and wild-type virus. **(C)** Reverse transcription polymerase chain reactions (RT-PCRs) with or without reverse transcriptase (RT) on packaged RNAs extracted from virions purified from *N. benthamiana* tissues co-infiltrated with replicase mutant and wild-type virus. Lanes 1-4: PCR products with primer pair, 2155F and 2565R. Lanes 6-9: PCR products with primer pair, Mut2155F and 2565R. Lanes 1 and 6: replicase mutant+wild RNAs with RT, Lanes 2 and 7: replicase mutant+wild RNAs without RT, Lanes 3 and 8: replicase mutant plasmid DNA, Lanes 4 and 9: wild-type plasmid DNA, Lane 5: 1-kb plus ladder. The migrations of SbDV genomic RNA (gRNA), LsgRNA and small subgenomic RNA (SsgRNA) are indicated.

SUMMARY

Soybean dwarf virus (SbDV), a member of the family *Luteoviridae*, is phloem-limited and persistently transmitted by colonizing aphids. In the United States, SbDV has been detected in soybean in Virginia and two Midwestern states, Illinois and Wisconsin. The main objectives of the present study were to develop a system to introduce cDNA clones of the virus into plants and use this system to identify regions of the viral genome involved in encapsidation of SbDV RNAs. The other objectives were to study the sequence diversity of the readthrough protein (RTP) of SbDV, which is believed to have a significant role in specificity of aphid transmission of other luteovirids, analyze the vector potential of soybean aphids (*Aphis glycines*) and the occurrence of adaptational mutations in RTP as a result of aphid transmission of SbDV into soybean.

Full-length viral genomes of one clover (CIIL2) and one soybean isolate (W4) were cloned into a binary vector and introduced into disarmed *Agrobacterium tumefaciens*. Local infections were detected with both SbDV isolates in agroinfiltrated leaves, but systemic infections were observed only with the CIIL2 isolate when *Agrobacterium* suspensions were injected into petioles, stems and veins of fava bean, *Nicotiana benthamiana*, 'Puget' pea and red clover. Attempts to transfer the progeny virus with aphid vectors from either locally or systemically infected tissues were not successful.

Encapsidation assays were conducted by northern blot analysis of sucrose-gradient-purified CIIL2, W4 and CIAGT2, a second red clover SbDV isolate. The red clover isolates CIIL2 and CIAGT2 encapsidated both genomic RNA (gRNA) and small subgenomic RNA (SsgRNA), while the soybean SbDV isolate, W4, packaged only gRNA. Rapid amplification of cDNA end analysis showed that encapsidated small RNAs corresponded to SsgRNA. To analyze the roles of RTP and 3' untranslated region (UTR) in differential packaging of SsgRNA, these regions of W4 isolate were replaced with that of CIIL2. The recombinant virus with 3' UTR of CIIL2 encapsidated SsgRNA, which indicated the involvement of the 3' UTR in SsgRNA encapsidation.

Site-specific and deletion mutations were introduced into the coding regions and interacting stem-loop structures in the 5' and 3' UTRs to identify packaging signals for SbDV gRNA. Agroinfiltration of the mutants into *N. benthamiana* indicated that, ORFs 1, 2, 4, and 5 and the interacting stem-loops in the 5' and 3' UTRs were required for replication of SbDV gRNA. Non-replicating mutants were *trans*-encapsidated by coat protein (CP) provided by replicating wild-type virus, which suggested that encapsidation of SbDV gRNA was independent of replication. Preferential encapsidation of large subgenomic RNA (LsgRNA) and mutant gRNA was observed in tissues co-infiltrated with wild-type helper virus and ORF1 and ORF5 deletion mutants, respectively.

Analysis of amino acid sequence diversity of RTPs, which are composed of the CP with a C-terminal extension known as the readthrough domain (RTD), of 24 dwarfing isolates of SbDV, revealed 56 amino acid substitutions in the 54-kDa RTD compared to only five in the 22-kDa CP. Phylogenetic analysis of both amino acid and nucleotide sequences showed three distinct clusters of SbDV isolates. One of the Illinois clover isolates was transmitted with low efficiency by *A. glycines*. There were no mutations occurred in the RTP as a result of aphid transmission of SbDV from red clover into soybean plants.

The present study demonstrated that SbDV encapsidates both gRNA and SsgRNA and the packaging signal for the SsgRNA was in the 3' UTR and its encapsidation was isolate-specific. Preferential *trans*-encapsidation of LsgRNA and mutant gRNA in ORF1 and ORF5 deletion mutants respectively indicated the involvement of two signals that are located in ORF1 and ORF5 that differentially regulate encapsidation of SbDV LsgRNA and gRNA.