

Fundamental Study on the Influence of SSC to Digital Television Reception

著者	Iwao Enisei, Kuwabara Nobuo
journal or publication title	2009 International Symposium on Electromagnetic Compatibility
page range	401-404
year	2009-07-20
URL	http://hdl.handle.net/10228/00008530

doi: <https://doi.org/10.34385/proc.14.22P3-2>

Fundamental Study on the Influence of SSC to Digital Television Reception

Enisei IWAO^{#1}, Nobuo KUWABARA^{#2}

[#] Graduate School of Kyushu Institute of Technology

1-1 Sensui-cho, Tobata-ku, Kitakyushu-shi, 804-8550, Japan

¹ E-mail: † iwao@buddy.elcs.kyutech.ac.jp

² E-mail: † kuwabara.nobuo@buddy.elcs.kyutech.ac.jp

Abstract - Spread Spectrum Clocking (SSC) is used for many PCs to satisfy a regulation of emission. The SSC affects to the wideband radio communication system, such as wireless LANs, compared with the narrow band radio communication system because SSC has a wide band spectrum. In this paper, the influence of SSC to the digital TV signal was compared with the influence to the analogue TV signal. A frequency modulation (FM) signal was used instead of the SSC signal. And these signals were impressed to both the analogue and the digital TV signal simultaneously. The received image quality was evaluated by the mean opinion score (MOS). The ratio of the disturbance to the broadcast signal level (DU ratio) was used as the parameter. The quasi peak level was used to calculate the DU ratio. The results indicated that the difference of DU ratio, when FM and AM signal were impressed to the TV signals, was small in the case of analogue TV, but the deviation of DU ratio is about 15 dB in the case of a digital TV. The results also show that the DU ratio of the digital TV was 20 dB lower than that of the analogue TV when MOS was 3.

Key words: Spread spectrum clocking (SSC), Digital TV, Analogue TV, DU ratio

I. INTRODUCTION

The disturbances emitted by information technology equipment (ITE) such as PCs and telecommunications equipment influences the reception of the television (TV) signal. International Special Committee for Radio Interference (CISPR) has published the limits and measurement method of the disturbances [1]. However, the limits intend the analog TV systems. Recently, TV broadcasting shifts from the analog TV systems to the digital TV systems. Therefore we should investigate the influences of the digital TV system by the disturbances because the spectrum of digital TV systems is completely different from that of analog TV systems [2].

Especially, a lot of recent PCs employ the spread spectrum clocking (SSC) to reduce the measurement disturbance level specified by the CISPR publications [3]. The influence of SSC signal for the wideband communication system such as wireless LANs becomes more serious than that for the narrow band communication system such as FM radio [4] because the SSC spreads the clock to a wideband. The influence to the digital TV signal should be investigated because the TV signal has a wideband spectrum.

In this paper, we investigate the influence to the digital TV signal compared with the influence to the analog TV signal

because the analog TV system already operates in the environment where SSC signal exists. A FM signal is used instead of the SSC signal and it is impressed to both the analog and the digital TV signal simultaneously. The actual TV broadcast signals are used for the experiment. The received image quality is evaluated by the mean opinion score (MOS), and the ratio of the disturbance to the broadcast signal level (DU ratio) are used as the parameter. The quasi peak level is used to calculate the DU ratio. The relation between the DU ratio and the signal level, the relation between the DU ratio and the kind of the disturbances, and the relation between the DU ratio and the kind of the TV systems are investigated.

II. SPECTRUM OF UNDESIRABLE AND DESIRED SIGNAL

A. Spread Spectrum Clocking and FM Signal

The example of SSC is shown in Fig. 1. This shows the peak value and quasi-peak (QP) value of SSC, where the resolution bandwidth (RBW) of the spectrum analyzer is 120 kHz. The center frequency is around 401 MHz and the spectrum bandwidth is around 3 MHz.

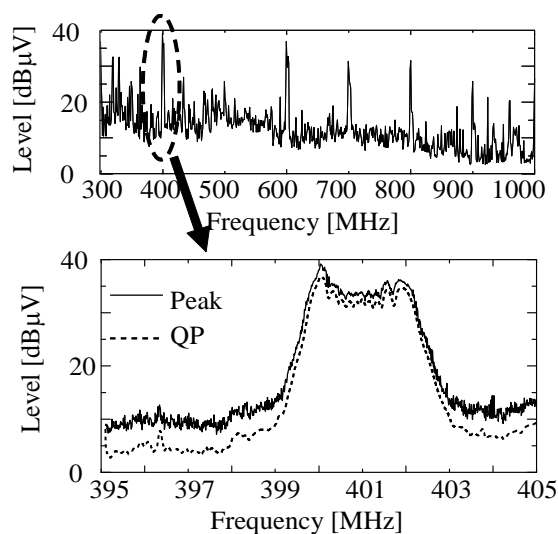

Fig. 1 Example of SSC spectrum

The SSC spread the clock of PCs beyond 120 kHz, where 120 kHz is the bandwidth specified by the CISPR Publication [1]. The disturbance level of the clock decreases until 10dB by using the SSC because the measured level is the energy existing in the bandwidth of 120 kHz [4].

It is difficult to change the frequency and the spectrum bandwidth of SSC. Therefore, we used the FM signal instead of the SSC signal. The example of FM signal is shown in Fig. 2. The frequency deviation is ± 2 MHz and the shift speed is 50 μ s per cycle. The bandwidth of spectrum analyzer is 120 kHz. In this figure, the solid line shows the peak value and the dotted line shows the QP value, where QP value is the specified value by CISPR and the limits of CISPR is presented by this value [1]. This figure shows that the QP level is 2 dB lower than the peak value.

As shown in this figure, the level of the spectrum is larger at the edge of the spectrum than that at the center. We define the undesired level by the QP level at the center of the spectrum.

In this figure, the AM signal is also shown as an example of the narrow band disturbances. The modulation level is 80% and the modulation frequency is 1 kHz. The solid line is the peak value and the dotted line is the QP value. This shows that the QP value is almost the same as the peak value.

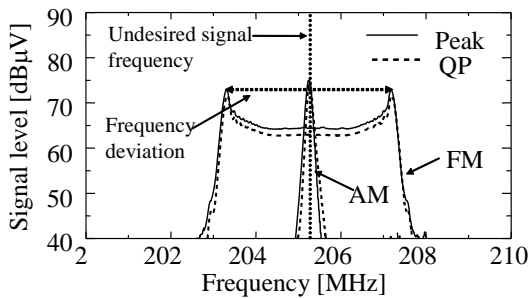

Fig. 2 Example of FM signal used for disturbance

B. Analogue and Digital TV Signal Spectrum

Both analogue and digital TV signal exist in Japan until 2011. Therefore, we use the actual TV signal for the evaluation.

Examples of received TV signals are shown in Figs. 3(a) and 3(b). Figure 3(a) shows the spectrum of an analogue TV signal. The solid line shows the peak value and the dotted line shows the QP value. The analog TV system uses a vestigial sideband modulation method and the spectrum has three peaks which are the sound carrier, the image carrier, and the color sub carrier. This shows that the QP value is 4 dB lower than the peak value at these peaks, and the QP value at the other frequencies is around 10 dB lower than that of the peak value. The QP value at the image carrier was used as the desired signal level in this investigation.

Figure 3(b) shows the spectrum of the digital TV signal. The digital broadcast whose program was the same as the analogue TV was selected for comparing the quality of the image. The solid line shows the peak value and the dotted line shows the QP value. The digital TV system uses the

orthogonal frequency division multiplexer (OFDM) and the spectrum is almost flat in the frequency band. This figure shows that the QP value is around 5 dB lower than that of the peak value. The QP value at the center frequency of the spectrum was used as the desired signal level in this investigation.

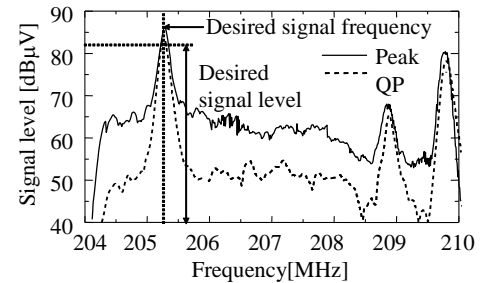

(a) Spectrum of analogue TV

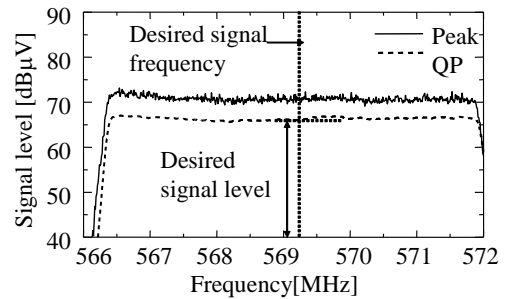

(b) Spectrum of digital TV

Fig. 3 Peak and quasi-peak (QP) value of analogue and digital TV signal

III. EXPERIMENT

A. Experimental Set-up

Experimental set-up for evaluating the image quality when disturbances are impressed to the TV signal is shown in Fig. 4.

The FM signal was generated by using a function generator and it converted to two frequencies by mixers. One is the frequency for the analogue TV in Fig. 3(a) and the other is the frequency for the digital TV in Fig. 3(b). These FM signals were combined by a power divider and adjusted to the appropriate level by an attenuator.

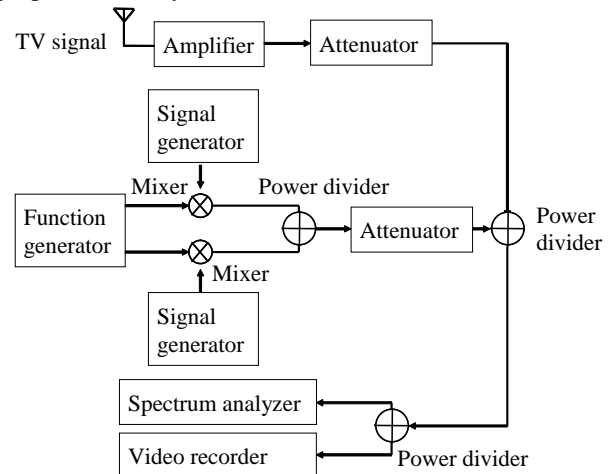

Fig. 4 Experimental set-up for measuring image quality

The received TV signal was amplified and adjusted to the appropriate level by an attenuator. Here, the amplifier was used for suppressing the FM signal radiation via a receiving antenna.

FM signals and TV signals combined each other by the power divider. The combined signal is recorded by the video recorder using hard disk and it was also monitored by spectrum analyzer. An example of monitored spectrum for analogue TV signal is shown in Fig. 5. In this figure, the solid line is the TV signal and the dotted line is the FM signal. The ratio of desired signal level to undesired signal level (DU ratio) was used for the investigation and it is defined by the following equations.

$$DU [dB] = Desired [dB\mu V] - Undesired [dB\mu V] \quad (1)$$

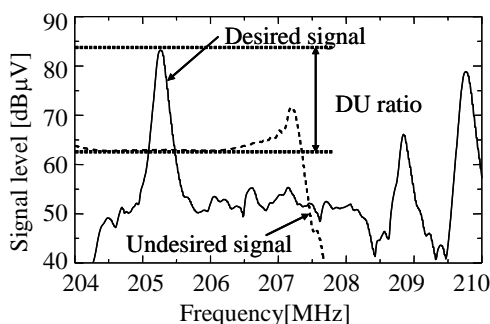

Fig. 5 experimental set-up for measuring image quality

B. Evaluation Method of Image Quality

The most general method of the subjective evaluation methods uses the mean opinion score (MOS).

In this method, the image quality is divided into 5 levels as shown in Table 1. Many people see the image and present the score. The mean value of the scores was used as MOS value. In this experiment, the recorded image is projected on a screen and six people participated in the experiment.

TABLE I
IMAGE QUALITY AND SCORE

Score	5	4	3	2	1
Image quality	Best	Better	Good	Worse	Worst

IV. EXPERIMENTAL RESULTS

A. Dependence of TV signal level

Figure 6 shows the dependence of the TV signal level. On the experiment, the analogue TV signal level was changed from 72 dBμV to 52 dBμV, and the digital TV signal level was changed from 45 dBμV to 25 dBμV. In this figure, the horizontal axis shows the DU ratio and the vertical axis is the MOS value. This shows that the relations between the DU ratio and the MOS value do not change in the case of both the analogue and digital TV signal when the TV signal level

changes. This means that the TV signal level does not influence the susceptibility to the disturbances.

When the MOS value is 3, DU ratio is around 8 dB in the case of digital TV and the DU ratio is around 25 dB in the case of the analogue TV. This means that the susceptibility of the digital TV is around 20 dB lower than that of the analogue TV.

We can not decide that the susceptibility of the digital TV for the disturbances is lower than that of the analogue TV because this deviation changes by the measurement method of desired and undesired level.

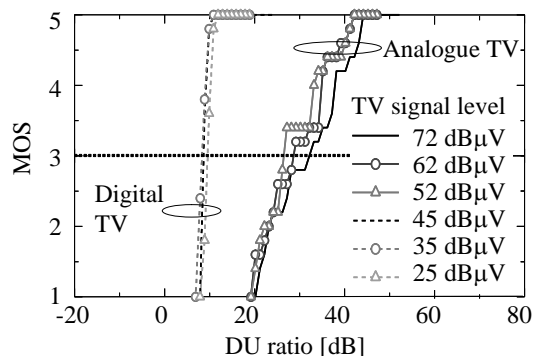
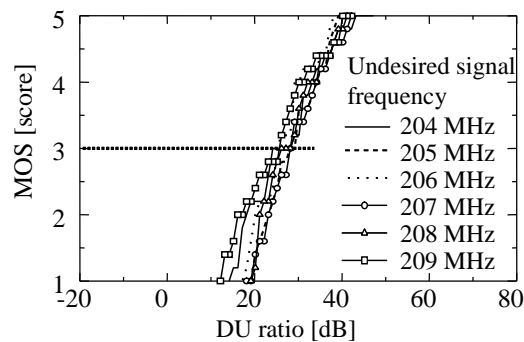

Fig. 6 Dependence of TV signal level

B. Dependence of Disturbance Position

The disturbance frequency was changed in the frequency band of the TV signal and the change of the image quality was investigated. The results are shown in Figs. 7(a) and 7(b).



(a) Analogue TV

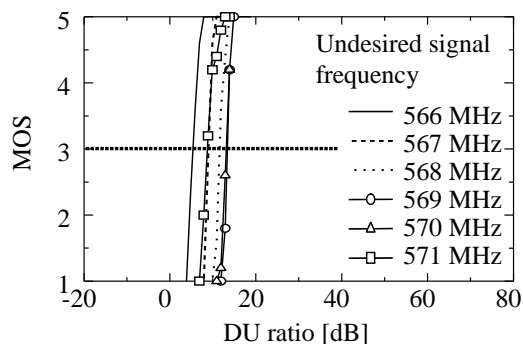

(b) Digital TV

Fig. 7 Dependence of disturbance frequency position

In the experiment, the analogue TV signal level was 62 dB μ V and the digital TV signal level was 35 dB μ V respectively. The disturbance frequency was changed from the lower end of the TV signal frequency band to the upper end at intervals of 1 MHz.

Figure 7(a) shows that the influence of the frequency position increases when the MOS level decreases. The deviation of DU ratio is around 5 dB when the MOS is 3. Figure 7(b) shows that the influence of the frequency position is independent of the MOS level and the deviation of the DU ratio is around 10 dB when the MOS is 3.

The results indicate that the digital TV signal is more sensitive to the frequency position of the disturbances than the analogue TV signal. Figure 7(b) also shows that the DU ratio is large when the frequency is from 568 MHz to 570 MHz. This reason might be thought that the overlap rate of the TV signal spectrum and the disturbance spectrum is large in these frequencies.

C. Dependence of Disturbance Kind

SSC signal and non-SSC signal were impressed to the TV signals and the deterioration of the image quality was examined by MOS. The investigation result is shown in Fig. 8.

In this figure, the dotted line with the black circles is the result when the disturbance is non-SSC and the TV system is digital, the dotted line with the black triangles is the result when the disturbance is SSC and the TV system is digital, the solid line with the white circles is the result when the disturbance is non-SSC and the TV system is analogue, and the solid line with the white triangles is the result when the disturbance is SSC and the TV system is analogue.

The FM signal and AM signal shown in Fig. 2 were used as the SSC and the non-SSC signal respectively. As shown in Fig. 2, SSC signal has wideband spectrum and non-SSC signal has narrow band spectrum. The frequency of the disturbance is 205 MHz for the analogue TV and 567 MHz for digital TV.

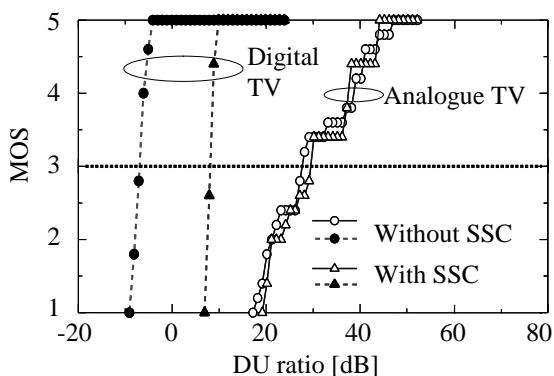

Fig. 8 Dependence of kind of disturbances

The results show that the analogue TV signal is independent from the kind of disturbances. On the other hand, the DU ratio changes by the kind of disturbances in the case of the digital TV. The results suggest that the susceptibility of the digital TV for the wide band disturbances is higher than that for the narrow band disturbances.

V. CONCLUSION

Spread spectrum clocking (SSC) is widely used to reduce the disturbance level measured by the specification of CISPR. However, this method has a possibility not to reduce the influence in the case of the digital TV signal because the TV signal has a wideband spectrum.

The SSC signal was replaced by the FM signal and impressed to both analogue and digital signal simultaneously. The image quality was evaluated by using the same image. The quasi-peak (QP) value which was widely used to measure the disturbance level was used to evaluate the ratio of desired and undesired (DU ratio).

The investigation results show that the relation between the DU ratio and the MOS value does not change in both the analogue and digital TV signal when the TV signal level changes, and the digital TV signal is more sensitive to the disturbance frequency and the kind of disturbances than the analog TV signal.

The investigation also shows that the susceptibility of the digital TV is around 20 dB lower than that of the analogue TV. However, we can not decide that the susceptibility of the digital TV for the disturbances is lower than that of the analogue TV because this deviation changes by the measurement method of desired and undesired level.

Future problem is the study of the mechanism where the image deterioration occurs caused by the SSC.

ACKNOWLEDGMENTS

This study is supported by MEXT.KAKENHI(20560360)

REFERENCES

- [1] IEC/CISPR Publication 22 Edition 5.2, "Information technology equipment - Radio disturbance characteristic - Limits and methods of measurement," March 2006
- [2] K. Gotoh, Y. Matsumoto, H. Tsutagaya, and S. Kazama, "Evaluation of sensitivity of digital TV receiver subjected to intrasystem interference," EMC Europe 2008, Hamburg, pp. 727 - 730, Sep. 2008.
- [3] Harry G. Skinner, "Why spread spectrum clocking of computing devices is not cheating" 2001 IEEE EMC International Symposium, Montreal, pp.537-540, Aug. 2001
- [4] O. Aoki, F. Amemiya, A. Kitani, and N. Kuwabara, "Investigation of interferences between wireless LAN signal and disturbances from spread spectrum clocking," 2004 IEEE EMC International Symposium, Santa Clara, pp. 505-510, Aug. 2004