

THE ROLE OF CASE-MARKED NOUN PHRASES IN CLAUSE STRUCTURE BUILDING

BY
WOOSEUNG LEE

DISSERTATION

Submitted in partial fulfillment of the requirements
for the degree of Doctor of Philosophy in Linguistics
in the Graduate College of the
University of Illinois at Urbana-Champaign, 2009

Urbana, Illinois

Doctoral Committee:

Professor Hye Suk James Yoon, Chair
Professor Elabbas Benmamoun
Professor Peter Lasersohn
Assistant Professor Karlos Arregui-Urbina

ABSTRACT

The goal of this thesis is to investigate the pervasive role of case-markers in the morpho-syntax of various constructions in heavily dependent-marking languages such as Korean and Japanese. I show that Case plays a special role in Korean, unlike in other languages (e.g. German) by comparing the morphosyntax (and prosody and interpretation) of two types of nominal coordinations that are differentiated by the presence/absence of the case-marker in the initial conjunct. I then develop a novel system, which I call the “Incremental C-selectional Combinatoric Analysis”, in which case markers or other combinatoric markers are crucially implicated in the structure building. I also demonstrate how some of the traditional issues revolving around the so-called null categories – both null arguments and null predicates – are resolved; null predicates are licensed strictly by syntax, while null arguments are not syntactically licensed. Rather, missing arguments mean the structural absence of the arguments. The constructions that I am focusing on in this investigation include different types of Noun Phrase Coordinations, Right Node Raising (RNR) Constructions, Coordination under Right Node Raising (CoRNR) Constructions, Null Argument Constructions and Right-Dislocation Constructions in Korean/Japanese. First, I discuss how the null predicate is licensed and gets interpreted in coordination contexts such as Type A/B nominal coordinations, RNR as well as CoRNR constructions. The null predicate is syntactically licensed by the (combined) case-marked NPs in the initial conjunct. The contents of this null predicate are cataphorically resolved when the overt predicate in the final conjunct is encountered. I then discuss the syntax of Null Argument Constructions. Unlike the proposals made so far, I propose that null arguments mean structural absence of the arguments. Specifically, missing elements are not syntactically

projected at all. Finally, I analyze Right-Dislocation Constructions as bi-clausal, which are composed of a host clause and an appendix clause containing a null predicate. The null predicate in the appendix clause receives anaphoric interpretation by being co-indexed with the overt predicate in the host clause. Before closing with some implications of the proposed analysis, I discuss how to handle sentences with some case-drop or without case-markers at all. I propose that they are asyntactically formed.

ACKNOWLEDGMENTS

I would like to express my deepest gratitude to my advisor James Yoon, who has given me valuable advice and comments at various stages of my dissertation. I really enjoyed meeting with him on a regular basis, which finally helped me complete this dissertation. Also, throughout the most difficult times when I was on medical leave, he encouraged me to continue research in Korea by sending me papers and comments. Without his encouragement and help, this dissertation would not have seen the light of the day.

My deepest thanks also go to Professor Abbas Benmamoun, who, as a department head, has also greatly helped me resume studies after my leave. He has been very encouraging and helped me get a fellowship to complete this dissertation. His insightful comments and questions on my dissertation have always been seriously considered and truly appreciated.

I also greatly thank Professor Peter Lasnik, who introduced the field of semantics to me for the first time. I enjoyed taking his seminars on various subtopics of semantics and also learned about Categorical Grammar by taking an independent study with him. His patience and detailed explanation provided a great example of what a good teacher should look like.

I am especially indebted to Professor Karlos Arregi, who was at UIUC for five years but is now at the University of Chicago. I was fortunate to have him as one of my committee members and have the chance to do an independent study and get invaluable comments and questions. I was really sad when he left.

I would also like to express my heart-felt gratitude to Professors Yamuna and Braj Kachru. I have worked with Professor Yamuna Kachru as her research assistant for the past 6

semesters. While working with her, I had both financial and moral support and had the chance to read sociolinguistics books and papers that I otherwise would not have had the chance to read.

My gratitude also goes to Professor Taegoo Chung at Korea University, who first opened my eyes to Syntax in my sophomore year and motivated me to pursue the study of linguistics. All my curiosity and inquiry started while taking his courses, and he was very encouraging and responsive to my questions. Without having taken his courses, I would say I might not have begun pursuing a PhD in linguistics.

I also thank Professor Hee-Rhak Chae, who I first got to know when he came to UIUC as a visiting professor on sabbatical leave. I was lucky to get valuable comments from him when I presented my papers at conferences.

My life at UIUC has been enriched by many colleagues and friends. There are too many to name, but I would like to mention Juhyeon Hwang, Yunchul Yoo and Bohyun Kim. We were in the same dissertation group and studied together for the last 1 or 2 years when I was writing up this dissertation. Many thanks to Youngsun Lee, who kindly gave me a home and moral support for the last 5 months. I would like to express my special thanks to Youngju Choi, now a professor at Chosun University. Though she was my colleague, she was almost like a mentor to me. I not only sought her advice about my personal problems, but also consulted her with my studies and linguistic data analysis. Her sincere encouragement while I was depressed is deeply appreciated.

Outside of the department, I was extremely fortunate to have many friends at the Korean Church of Champaign-Urbana, and a cousin, Kyoungghwa Lee, who is now a professor in English literature at Dankook University. Though studying at different universities, we

shared all our struggles and joyful moments.

Most of all, I would like to thank my mom and two sisters, with whom I shared all my laughter and tears. Their patience and everlasting love as a family -- now is the time I should return to them.

Finally, I would like to remember my father, Youn-Shik Lee, in heaven, who would be so eager and happy to see the completion of this dissertation more than anyone else. He was the best father one can ever have. He gave me nothing but endless love, praises, understanding and encouragement. I hereby dedicate this dissertation to my father.

TABLE OF CONTENTS

LIST OF ABBREVIATIONS.....	viii
CHAPTER 1: INTRODUCTION.....	1
1. Introduction.....	1
2. Overview.....	10
CHAPTER 2: TWO TYPES OF NP COORDINATION CONSTRUCTIONS IN KOREAN: CASE-MARKED NP COORDINATIONS AS CLAUSAL/ SENTENTIAL CONJUNCTIONS UNDER THE INCREMENTAL C-SELECTIONAL COMBINATORIC ANALYSIS.....	17
1. Basic Phenomena: (A)symmetry in Case-marking in Nominal Coordinations.....	19
2. Two Types of NP Coordinations.....	23
3. Need for an Alternative Analysis.....	39
4. An Alternative Analysis: the Incremental C-selectional Combinatoric Analysis.....	42
5. Conclusion.....	81
CHAPTER 3: RIGHT NODE RAISING CONSTRUCTIONS IN KOREAN.....	83
1. Properties of RNR Constructions.....	86
2. Review of Previous Proposals.....	99
3. An Alternative Analysis.....	116
4. Advantages.....	128
5. Extension of the Analysis to CoRNR Constructions.....	131
6. Conclusion/Implications.....	140
CHAPTER 4: RIGHT DISLOCATION IN KOREAN AND JAPANESE.....	142
1. Introduction.....	142
2. Various Properties of Right-Dislocation Constructions in Korean.....	144
3. Previous Proposals.....	159
4. The Proposal.....	177
5. Summary and Case-Drop in RD.....	237
CHAPTER 5: CONCLUSION.....	240
REFERENCES.....	246

LIST OF ABBREVIATIONS

Acc: Accusative Case

Conj: Conjunction

Comp: Complementizer

Cop: Copular

Dat: Dative Case

Decl: Declarative

Gen: Genitive Case

Kes: Kes (Korean Nominalizer)

Loc: Locative

Neg: Negation

Nml: Nominalizer

Nom: Nominative Case

NPI: Negative Polarity Item

Prs: Present

Pst: Past

Rel: Relative Pronoun/Relativizer

Chapter 1:

Introduction

1. Introduction

The goal of my thesis is to investigate the pervasive role played by case-markers in the morpho-syntax of various constructions in heavily dependent-marking languages such as Korean and Japanese. A dependent-marking language is one where grammatical markers showing relations between different constituents of a phrase tend to be placed on dependents or modifiers rather than heads of the phrase in question. In a noun phrase, for example, the head is the main noun and its dependents are articles, adjectives, possessives, etc. In a verb phrase, a verb is the head and its dependents are arguments (i.e., subjects, objects, etc.). Typical examples of almost purely dependent-marking languages are Korean/Japanese, where every argument in a sentence is marked for its function (topic, subject, object, complement), while the verb is completely devoid of morphological markers showing person, number, gender, or any other properties¹ of the arguments (Wikipedia).

In the GB/minimalism tradition, it has been believed that case is assigned to or checked against each nominal by a predicate, and many proposals have been made to that effect in accounting for case patterns observed in various constructions in these languages. Various overtly-marked case-marking patterns in Korean and Japanese have called for attention and well deserved analyses, but most of the analyses proposed so far are so called microparametric approaches in the sense that they posit various small parameters specific to a certain language to account for its own unique case patterns. Under these approaches, case markers play a passive role in syntax as they

¹ The only agreement morpheme is the honorific *-si*, which agrees with the subject honorification *-kkeyse*.

are assigned by predicates and do not participate in syntactic combinations.

However, there are several studies where the case-markers actively participate in the syntactic combinations; Categorical Grammar (CG) or Combinatory Categorical Grammar (CCG) (Dowty 1988; Steedman 1982, 1985, 1990), O’Grady (1991, 1998, 2002, 2004a, b), Yu-Cho and Sells (1995), Kiaer and Kempson (2005) and Y-J Choi (2007). Especially, in CG/CCG (Dowty 1988; Steedman 1982, 1985, 1990), Steedman specifically suggests the possibility that case markers in languages with case-marking function to type-raise nominals. Therefore, a subject and an object can combine first before combining with a predicate through type-raising of arguments (Steedman 1990:235).

In a similar vein, Y-J Choi (2007) put forward a macro-parameter called the Dependent Marking Parameter (DMP) (1) for dependent-marking languages based on observations of several constructions including Fragments, Argument Clusters Coordinations, Clefting and Scrambling in Korean and Japanese, which will be discussed in detail in Section 1.2.

(1) Dependent Marking Parameter: Argument-Centeredness

Arguments combine, in a cluster, to select their predicates with the help of dependent markers.

Providing a DMP-based account² of each construction, Choi showed that case markers (or dependent markers) are responsible for argument combinations, and that the combined arguments as a whole select a compatible predicate rather than vice versa.

Adopting her analysis with some adaptations, I propose a novel analysis, which I call the “Incremental C-selectional Combinatoric Analysis”. Before presenting the Incremental C-

² This is a feature/unification based categorial system.

selectional Combinatoric Analysis in detail in the next Chapter, I introduce representative studies that my proposal is based on; Categorical Grammar (CG) or Combinatory Categorical Grammar (CCG) (Dowty 1988; Steedman 1982, 1985, 1990), Yu-Cho and Sells (1995), Y-J Choi (2007) and Philips (2003).

1.0 Categorical Grammar or Combinatory Categorical Grammar (Dowty 1988; Steedman 1982, 1985, 1990)

In Categorical Grammar or Combinatory Categorical Grammar (CG or CCG), through type-raising³ of arguments, a subject and an object can combine first before combining with the predicate. As a representative example, to account for a gapping construction (Steedman 1990:235) such as (2), Steedman proposes an English Forward Mixing Composition rule to show the category of the right conjunct and the Left Conjunct Revealing Rule as shown in (3) and (4) respectively.

(2) Harry eats beans, and Barry, potatoes.

(3) English Forward Mixing Composition rule

$$[X/Y]_{\&} \quad YZ \quad \rightarrow \quad [XZ]_{\&}$$

where $Y = S \setminus NP$

(4) The Left Conjunct Revealing Rule (<decompose)

$$X \rightarrow Y \quad X \setminus Y$$

Where $X = S$

And $Y = \text{given}(X)$

³ Steedman specifically suggests the possibility that case markers in languages with case-marking function to type-raise nominals. According to Steedman, in languages like Korean and Japanese, a subject and an object can combine first before combining with a predicate through type-raising of arguments (Steedman 1990:235).

The two rules first allow the non-constituent *Harry, beans* to conjoin with *Barry, potatoes* and then, these non-constituent coordinations combine with the verb finally. This CCG-based account provides a foundation for an analysis where arguments (subjects and objects) combine first in a left-to-right fashion and then take a predicate in SOV languages such as Korean and Japanese.

1.1 Yu-Cho and Sells (1995)

Yu-Cho and Sells (1995) is another antecedent which my proposal is based on. Specifically, they proposed that inflectional affixes choose a sister of a root to which they attach. When a root has a nominative or an accusative marker, [TYPE: V-SIS] is percolated to its maximal node so that its sister acquires a verbal form. When a root has a genitive marker, [TYPE: N-SIS] is percolated to ensure that its sister has a nominal form. They proposed a binary branching, right headed structure within Lexical Functional Grammar (LFG) as in (5) and an inflectional structure as in (6), where grammatical information flows from bottom to top.

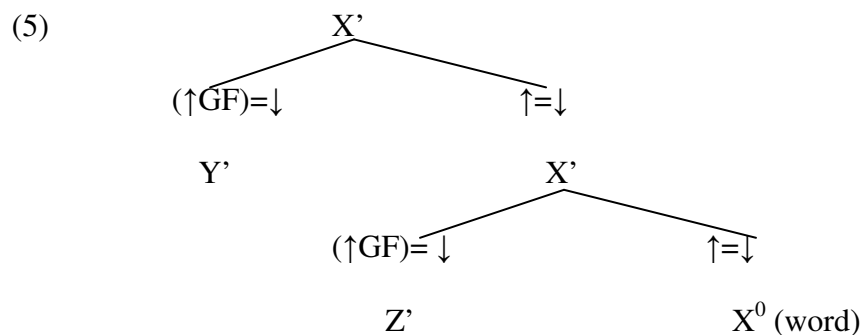

(6) Information Flow in inflectional structure

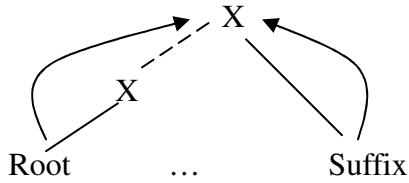

Categorical information Combinatoric information

As an example, they provided a structure of the sentence *kim-uy chinkwu-ka wus-ess-ta* ‘Kim’s friend laughed’ as represented in (7). The category of ‘kim-uy’ is noun, and it acquires a combinatoric feature [TYPE: N-SIS] by information flow shown in (5). Because the structure requires its sister to have a nominal form, ‘chinkwu-ka’ is chosen as its sister. Thus, the combined form ‘kim-uy chinkwu-ka’ has a combinatoric feature [TYPE:V-SIS] because its root has a nominative marker and its [TYPE: V-SIS] feature is percolated to ensure that its sister has a verbal form. Therefore, it successfully combines with the verb ‘wus-ess-ta’.

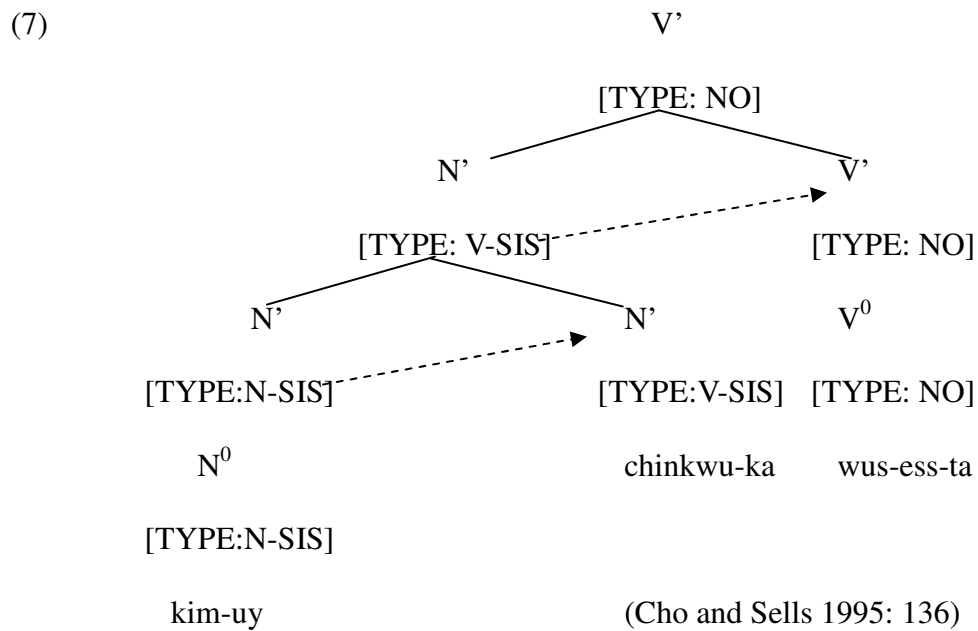

My proposal is similar to this approach in the sense that each inflectional/derivational affix (i.e. combinatoric markers in my proposal) carries feature specifications that makes it possible for its combination with a sister that satisfies its feature structure.

1.2 Y-J Choi 2007

Choi, who proposed a macroparameter for dependent-marking languages, offered an analysis called the Dependent Marking Parameter (DMP) Analysis on four constructions in Korean – Fragments, Argument Cluster Coordinations, Clefting and Scrambling. First, a distinction between the case marked and caseless fragments provides evidence for the dependent marking parameter. The presence of case markers makes a difference in whether to expect a (null) predicate in fragments. Fragments are divided into two types depending on presence or absence of case markers: case marked and caseless. The two types behave differently in forming multiple fragments and in showing case connectivity with sentential answers. Under the DMP assumptions, case-marked fragments, multiple or single, always require a predicate at LF, whereas caseless ones do not. Thus, in Korean and Japanese, multiple fragment answers are allowed (and prevalent) as in (6a-b), while in English they are not (7-8). In languages like Korean/Japanese, because of the presence of case markers, arguments combine in a cluster first looking for a compatible predicate. When NPs are not case-marked, multiple fragments are not possible as in (6c).

- (6) A: nwu-ka nwukwu-lul nwukwu-eykey sokayhay-ss-ci?
who-Nom who-Acc who-Dat introduce-Pst-Q
‘Who introduced whom to whom?’

B: John-i Mary-lul Bill-eykey
J-Nom M-Acc B-Dat
'John introduced Mary to Bill' (Korean)

C: *John Mary Bill

(7) A: Who introduced whom to whom?

B: *John Mary Bill

(8) A: Who bought what?

B: *John the book

Other studies have made similar points regarding constructions such as argument cluster coordinations and clefting. For example, argument cluster coordinations as in (9) have been discussed at length (Fukui and Sakai 2003; Fukushima 2003; Koizumi 2000; Takano 2002). However, most of these analyses are based on microparameters such as verb movement in head final languages (Koizumi 2000), oblique adjunction (Takano 2002), the absence of a functional category (Fukui and Sakai 2003) and the existence of a numeral classifier (Fukushima 2003).

(9) Cheli-ka sakwa-lul Tong-hako Yenghi-ka pay-lul Min-eykey cwu-ess-ta
C-nom apple-acc T-conj Y-nom pear-acc M-dat give-pst-decl
'Cheli gave apples to Tong and Yenghi gave pears to Min.'

However, these studies do not predict the prevalence of argument cluster coordination in comparison to Choi's assumption of argument centeredness. Dependent marking languages use a mode of combination different from that of non-Dependent Marking languages. That is,

arguments in DM languages first combine with each other and then select a predicate. As a result, they can occur in clusters in various constructions.

Clefting as in (10) is another construction that is naturally explained when the DMP is posited. Case-marking differences between Clefting constructions and regular constructions cannot be explained if movement is assumed. The DMP predicts that a single or multiple focus element in a focus position is not fragmentary but sentential, including a null predicate, which is reconstructed due to the presence of case markers in the focus element.

- (10)a. ok Yenghi-ka sakwa-lul cwun-kes-un Cheli-eykey-ita
Y-nom apple-acc give-kes-top C-dat-cop
- b.* Yenghi-ka mannan-kes-un Cheli-eykey-ita
Y-nom meet-kes-top C-dat-cop

Choi's research shows that case markers play a crucial role by comparing case marked and caseless NP (clusters) in various constructions. In the next chapter, I also show distinctive properties of case markers by presenting two types of nominal coordinations that are differentiated by the presence or absence of case-marker in the initial conjunct. This research motivates an analysis where case markers are crucially implicated.

1.3 Colin Philips (2003)

Philips' (2003) Incremental Structure Building as in (11) provides crucial background for my proposal.

(11) Incremental Structure Building

Sentence structures are built incrementally from left-to-right.

Combinatorial possibilities of grammatical heads are lexicalized, and it is the lexical features that license combinations of syntactic elements. Whenever a right-branching structure is assembled incrementally, certain strings are constituents at intermediate points in derivation but not in the final structure. (12a-b) show the general forms of constituent creation and destruction.

(12) a.

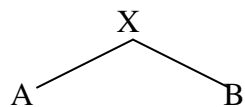

b.

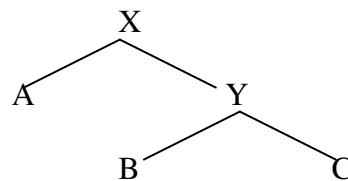

Philips offered an example as shown in (13), where the VP in the first tree (13a) contains only the verb and the string *Wallace saw* is a constituent. Notice that the effect of expanding the right-branching VP in (13b-c) is to destroy certain constituents that existed at earlier stages (e.g. *saw Gromit*). In this case, the addition of a preposition destroys the constituency of the verb+object string *saw Gromit*.

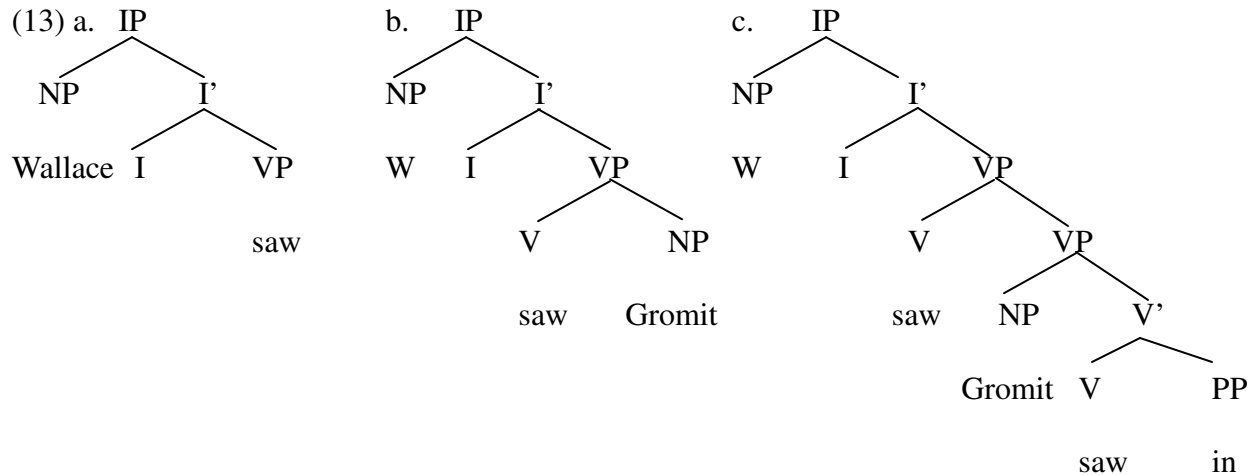

The Incremental C-selectional Combinatoric Analysis (ICCA) proposed in this dissertation is similar to Philip’s proposal in the sense that structures are incrementally built left-to-right as the sentence is parsed. The overall structure under ICCA grows as the existing structure encounters a combinatoric marker. That is, the combinatoric marker takes various phrases as its sister and incorporates them into the existing structure, thereby contributing to expansion of the whole structure.

2. Overview

In the previous section, I have briefly reviewed the literature relevant to my proposal – namely that clauses are built left-to-right by syntactic combinations of lexical elements with the help of combinatoric/dependent markers. Based on these ideas, I propose the Incremental C-selectional Combinatoric Analysis, in which combinatoric makers such as case markers, complementizers, relativizers, etc. are given feature specifications. I then illustrate how the proposed system accounts for simple sentences and sentences with clausal complements or embedded clauses. Furthermore, I will offer an analysis of a few other constructions that have received attention but

no satisfactory accounts; Type A and Type B Coordinations, Right Node Raising Constructions, Null Argument Constructions and Right-Dislocations. In this analysis, I discuss how null arguments or predicates are resolved or interpreted and how long-distance (interpretive) dependency can be accounted for better without resorting to movement-based accounts such as subjacency.

In Chapter 2, I introduce two types of Nominal Coordinations (Type A and B) and examine contrasting syntactic, semantic and prosodic properties between the two. Type A is represented as [NP-conj NP-case] and Type B, [NP-case conj NP-case], as exemplified in (14-16). Specifically, under the ICCA, Type A is analyzed as a constituent NP coordination and Type B as a clausal conjunction containing a null predicate in the initial conjunct. Other than the difference in morphosyntax (case-marking forms), the two types differ in prosody, interpretation, and syntactic distribution.

Prosodically, Type B conjunction is characterized by a pause after the first (case-marked) conjunct as in (14b), whereas in Type A, a pause is not necessary (14a).

Interpretively, (14a) describes a situation where John and Mary could have gone home together or separately, whereas (14b) implies separate events of John and Mary going home. Also, there is a temporal ordering in Type B coordination. Specifically, the event of ‘John’s going home’ happens before that of ‘Mary’s going home’.

The two types differ in syntactic distribution as well: Type A is a constituent NP coordination that displays a standard NP distribution whereas Type B is a clausal conjunction that diverges from standard NP coordinations.

(14)a. John-kwa Mary-**ka** cip-ey ka-ss-ta (Type A)

J-conj M-nom home-loc go-pst-decl

b. John-**i** kuliko Mary-**ka** cip-ey ka-ss-ta (Type B)

J-nom and M-nom home-loc go-pst-decl

‘John and Mary went home.’

(15)a. Na-nun John-kwa Mary-lul manna-ss-ta (Type A)

I-Top J-conj M-acc meet-pst-decl

b. Na-nun John-ul kuliko Mary-lul manna-ss-ta (Type B)

I-Top J-acc conj M-acc meet-pst-decl

‘I met John and Mary.’

(16)a. John-kwa Mary-**uy** cakpwum (Type A)

John-conj Mary-Gen work

‘John and Mary’s work’

b. John-**uy** kuliko Mary-**uy** cakpwum (Type B)

John-Gen conj Mary-Gen work

‘John’s and Mary’s work’

Afterward, I propose a novel analysis called the “Incremental C-selectional Combinatoric Analysis” (ICCA). I first show how the system works for various sentences including simple sentences, complex sentences with clausal complementation, embedded clauses, and scrambling. I then show how the two types of nominal coordinations can be analyzed and explained under the proposed analysis.

In Chapter 3, I discuss how null predicates are interpreted in coordination contexts such as

Right Node Raising (RNR) constructions as in (17) as well as Coordination under Right Node Raising (CoRNR) constructions as in (18).

(17) Cheli-nun sakwa-lul kuliko Yenghi-nun banana-lul acwu coaha-nta
 Cheli-Top apples-acc conj Yenghi-Top banana-acc a.lot like-decl
 = Cheli-nun sakwa-lul acwu coaha-nta kuliko
 Yenghi-nun banana-lul acwu coaha-nta
 ‘Cheli likes apples a lot and Yenghi likes bananas a lot’

(18) Cheli-ka Banana-lul kuliko Yenghi-ka sakwa-lul (kakkak)
 Cheli-nom Banana-acc conj Yenghi-nom apple-acc (respectively)
 coaha-ko silheha-n-ta
 like-conj dislike-pres-decl
 = Cheli-ka Banana-lul coaha-n-ta kuliko
 Cheli-nom Banana-acc like-pres-decl conj
 Yenghi-ka sakwa-lul silheha-n-ta
 Yenghi-nom apple-acc dislike-pres-decl
 ‘Cheli likes bananas and Yenghi dislikes apples’

Specifically, under the ICCA, case-marked NPs as a whole (sometimes with adverbs adjoined to the clusters) license a null predicate in the initial conjunct, and the contents of the null predicate are resolved when a “compatible” overt predicate in the final conjunct is encountered. “Compatibility” is defined when the predicate belongs to the Verb Class that the case-marked NPs license based on the verb classification discussed in Chapter 2 where a verb is classified

based on the case arrays and semantic/theta roles that the verb originally possesses. I then expand the analysis to several related constructions -- Coordination under RNR constructions (CoRNR Constructions by de Vos and Vicent 2005). CoRNR Constructions refer to those in which an RNR pivot is composed of conjoined predicates, which is related to the first and the second conjunct respectively. In these constructions, both the first and the second conjunct contain a null predicate, whose contents are resolved when the conjoined final predicates are parsed. Here, the relational modifier ‘respectively’ serves a crucial role in yielding the correct interpretation.

In Chapter 4, I discuss the syntax of Right-Dislocation Constructions⁴ as in (19).

- (19) a. Cheli-ka ecey Yenghi-lul manna-ss-ta
 C-nom yesterday Y-acc meet-pst-decl
- b. ecey Yenghi-lul manna-ss-ta Cheli-ka
 yesterday Y-acc meet-pst-decl C-nom
- c. Cheli-ka Yenghi-lul manna-ss-ta ecey
 C-nom Y-acc meet-pst-decl yesterday
- d. Cheli-ka ecey manna-ss-ta Yenghi-lul
 C-nom yesterday meet-pst-decl Y-acc

‘Cheli met Yenghi yesterday.’

Korean/Japanese Right-Dislocations (RD) are composed of a Host and an appendix. The Host is followed by an appendix, which is the element that follows the predicate/verb. As the Host contains null arguments (zero realization of a subject or an object or both) or adjuncts, I will

⁴ Various names are given to these constructions; Postposing Constructions (Sells 1999), Non-final Predicate Constructions (D-H Chung 2008)

briefly discuss constructions with null arguments that are shown in (20-22) before going into detailed discussion on RD.

(20)Q: Nwuku-ka ku ppang-ul mek-ess-ni?

Who-nom the bread-acc eat-pst-Q

‘Who ate the bread?’

A: Cheli-ka mek-ess-e

C-nom eat-pst-decl

‘Cheli ate (the bread).’

(21)Q: Cheli-ka mwues-ul sa-ss-ni?

C-nom what-acc buy-pst-Q

‘What did Cheli buy?’

A: chayk-ul sa-ss-e

book-acc buy-pst-decl

‘(Cheli) bought a book.’

(22)Q: Cheli-ka ku cha-lul ettehkey hay-ss-ni?

C-nom the car-acc how do-pst-Q

‘What did Cheli do with the car?’

A: phal-ass-e

sell-pst-decl

‘(Cheli) sold (the car).’

Under the ICCA, even if some arguments are missing, MP (Mood Phrase) is a well-formed,

complete sentence, and verbs do not need to be saturated because predicates are not functors requiring arguments. Constraints imposed on verbs state that they should be compatible with preceding KP (Case Phrase) clusters in terms of case array, and that verbs select the KPs semantically, not syntactically. Thus, the incompatibility results in ungrammaticality while the insaturation of verbs does not. Under this system, verbs are classified into different valence classes (cf. Canonical Sentence Perspective of S-Y Kuroda) and contain all relevant semantic information. Accordingly, even if some arguments are not present on the surface, the various meanings of the sentence are delivered successfully because the predicates carry all the semantic information they need. As pointed out earlier, the syntax of the host clause is basically the same as the syntax of the null argument constructions. On the other hand, the appendix (part) is proposed to contain a (locally licensed) null nominal or verbal predicate whose contents are retrieved by referring to the overt predicate/noun in the Host.

Prevailing views on Korean/Japanese Right-Dislocations (RD) all involve movement analyses in some form, presumably because RD constructions seem to exhibit subjacency-like effects. However, I propose that RD constructions are composed of two clauses, where a host clause is followed by a base-generated appendix clause. As an appendix arises through base-generation, there is no need to resort to a movement account such as subjacency. The apparent subjacency-like effects are instead a result of processing difficulties that arise from various other factors (Bever 1970; Chomsky & Miller 1963; Fanselow & Frisch 2006; Osterhout, Holcomb & Swinney 1994, cf. Deane 1991). I conclude this thesis by discussing the implications of the ICCA: I talk about how to handle examples with no case markers under the ICCA framework and suggest directions for future research.

Chapter 2:

Two Types of NP Coordination Constructions in Korean:

Case-marked NP Coordinations as Clausal/Sentential Conjunctions under the Incremental C-selectional Combinatoric Analysis

This chapter investigates two types of NP coordination constructions in Korean, which are distinguished by the distribution of case-markers and conjunctive markers. There are several patterns of nominal coordinations, but I will focus on the two types exemplified in (1-3), which have received more attention recently (Yoon and Lee (2005)). As each of the pairs in (1-3) show, case can be symmetrically marked on both conjuncts, or it can be asymmetrically attached to the final conjunct only. The (a)-examples of (1-3) are examples of the asymmetric case-marking (Type A), whereas the (b)-examples of (1-3) are examples of the symmetric case-marking (Type B). Type A represents sentences where case (Nom, Acc or Gen) is marked only on the final conjunct and non-final conjuncts carry the nominal conjunctive suffix *-(k)wa* (or other conjunctive suffixes such as *-hako, ilang*). In Type B sentences, case-markers occur on all conjuncts and *kuliko* occurs between the conjuncts.

(1) a. John-kwa Mary-**ka** cip-ey ka-ss-ta (Type A)

J-conj M-nom home-loc go-pst-decl

b. John-**i** kuliko Mary-**ka** cip-ey ka-ss-ta (Type B)

J-nom and M-nom home-loc go-pst-decl

‘John and Mary went home.’

(2) a. Na-nun John-kwa Mary-lul manna-ss-ta (Type A)

I-Top J-conj M-acc meet-pst-decl

b. Na-nun John-ul kuliko Mary-lul manna-ss-ta (Type B)

I-Top J-acc conj M-acc meet-pst-decl

‘I met John and Mary.’

(3) a. John-kwa Mary-**uy** cakphwum (Type A)

John-conj Mary-Gen work

‘John and Mary’s work’

b. John-**uy** kuliko Mary-**uy** cakphwum (Type B)

John-Gen conj Mary-Gen work

‘John’s and Mary’s work’

Yoon and Lee (2005) observe that there are some syntactic and semantic differences between the two types of coordination constructions. Specifically, in (1a), John and Mary could have gone home either together or separately. (1b), however, denotes two separate events of John going home and Mary going home. Usually, the two events are temporally ordered. Likewise, in (2a), I could have met John and Mary either at the same time in one event or at different times in two separate events. (2b), however, denotes two separate events of meeting John and meeting Mary at different times. (3a) denotes one piece of art work created collaboratively by John and Mary, while (3b) denotes two pieces of art works created independently by John and Mary. Before we discuss these two types in more detail, let us consider some basic phenomena exhibited in several types of nominal coordinations in general in Korean.

1. Basic Phenomena: (A)symmetry in Case-marking in Nominal Coordinations

Korean has various types of nominal coordinations shown in (4-7) with various coordinators - *hako*, *-ilang*, *-(k)wa* and *kuliko*. Pattern 1 in (4) represents constructions where all conjuncts are marked with an affixal coordinator. As *-hakol-langl-(k)wa* are largely interchangeable and *-(k)wa* is the most standard form, I give all examples with *-(k)wa* below.

(4) Pattern 1

Cheli-wa (kuliko) Yenghi-wa-(optional case-marker)

Cheli-conj (conj) Yenghi- conj

hakkyo-ey ka-ss-ta

school-to go-past-decl

‘Cheli and Yenghi went to school’

Pattern 2 involves constructions where each conjunct is case-marked and the ‘*kuliko*’ conjunctive occurs between the case-marked NPs, as in (5).

(5) Pattern 2

Cheli-ka kuliko Yenghi-ka hakkyo-ey ka-ss-ta

Cheli-nom conj Yenghi-nom school-to go-past-decl

‘Cheli and Yenghi went to school’

Pattern 3 represents the form in which an affixal conjunction is marked on non-final conjuncts and only the final conjunct is case-marked as shown in (6).

(6) Pattern 3⁵

Cheli-wa	(kuliko)	Yenghi-ka	hakkyo-ey	ka-ss-ta
Cheli-conj	conj	Yenghi-nom	school-to	go-past-decl

Pattern 4 is for cases where Cheli and Yenghi are conjoined by *kuliko* and case is marked only on the final conjunct as in (7).

(7) Pattern 4

Cheli	kuliko	Yenghi-ka	hakkyo-ey	ka-ss-ta
Cheli	conj	Yenghi-nom	school-to	go-past-decl

Now, let us test these patterns to see if they can occur in different grammatical positions, and in both matrix and embedded contexts. First, Pattern 1 can occur in the subject position as in (8a), but it cannot occur in the object position as in (8b). This can be embedded in a sentence as in (8c).

(8) a.	Cheli-wa	Yenghi-wa	nolay-lul	pwulu-ess-ta/ccak-i-ta
	C-conj	Y-conj	song-acc	sing-pst-decl/classmates-cop-decl
b.*	Tongswu-ka	Cheli-wa	Yenghi-wa	sileha-n-ta
	T-nom	C-conj	Y-conj	hate-pres-decl
c.	Tongswu-ka	Cheli-wa	Yenghi-wa	hakkyo-ey ka-ss-ta-ko
	T-nom	C-conj	Y-conj	school-to go-pst-decl-comp

⁵ Pattern 3, in limited cases as in (1), can be realized as ‘Cheli-hanthey-wa Yenghi-hanthey’, where the case marker is an inherent one.

(1)	Cheli-hanthey-wa	Yenghi-hanthey	ton-i	manh-ta
	C-dat-conj	Y-dat	money-nom	be.a.lot.of-decl

malhay-ss-ta

say-pst-decl

Pattern 2 can also occur in both subject and object position as in (9a-b). It also can be embedded in a sentence as in (9c).

(9) a. Cheli-ka kuliko Yenghi-ka hakkyo-ey ka-ss-ta

C-nom conj Y-nom school-to go-pst-decl

b. Tongswu-ka Cheli-lul kuliko Yenghi-lul manna-ss-ta

T-nom C-acc conj Y-acc meet-pst-decl

c. Tongswu-ka Cheli-ka kuliko Yenghi-ka hakkyo-ey

T-nom C-nom conj Y-nom school-to

ka-ss-ta-ko malhay-ss-ta

go-pst-decl-comp say-pst-decl

Pattern 3 can also occur in both subject and object position as in (10a-b). It can be embedded as well, as shown in (10c).

(10)a. Cheli-wa Yenghi-ka hakkyo-ey ka-ss-ta

C-conj Y-nom school-to go-pst-decl

b. Tongswu-ka Cheli-wa Yenghi-lul silhehay-ss-ta

T-nom C-conj Y-acc hate-pst-decl

c. Tongswu-ka Cheli-wa Yenghi-ka hakkyo-ey ka-ss-ta-ko
 T-nom C-conj Y-nom school-to go-pst-decl-comp
 malhay-ss-ta
 say-pst-decl

As to Pattern 4, speakers' judgments vary, but those who accept this pattern agree⁶ that this is the same as pattern 2, where the case-marker of the initial conjunct drops. Thus, this pattern behaves the same as Pattern 2 as shown in (11a-c).

- (11)a. Cheli kuliko Yenghi-ka nolay-lul pwulu-ess-ta
 Cheli conj Y-nom song-acc sing-pst-decl
- b. Tongswu-ka Cheli kuliko Yenghi-lul ttayli-ess-ta
 T-nom C conj Y-acc hit-pst-decl
- c. Tongswu-ka Cheli kuliko Yenghi-ka nolay-lul pwulu-ess-ta-ko
 T-nom C conj Y-nom song-acc sing-pst-decl-comp
 malhay-ss-ta
 say-pst-decl

As mentioned above, we focus on Pattern 2 and 3 since, even though they are different only in the case-marking of the initial conjunct NP, the difference will bring about non-trivial *contrastive* syntactic, semantic and prosodic properties between the two constructions as we will find in the next section. In other words, as they are *minimally* different in the presence and absence of the

⁶ Both Type 2 and Type 4 involve two separate events and there is a temporal ordering between two conjuncts. Also, pure collective predicates are disallowed. We will see these in the next section with specific examples in detail.

case-marker on the first conjunct NP, the comparison of these two constructions will contribute to finding the role of case-markers in coordination constructions and other constructions in general in Korean.

2. Two Types of NP Coordinations

The two types we focus on are repeated below for ease of reference (12-14).

(12)a. John-kwa Mary-**ka** cip-ey ka-ss-ta (Type A)

J-conj M-nom home-loc go-pst-decl

b. John-**i** kuliko Mary-**ka** cip-ey ka-ss-ta (Type B)

J-nom and M-nom home-loc go-pst-decl

‘John and Mary went home.’

(13)a. Na-nun John-kwa Mary-lul manna-ss-ta (Type A)

I-Top J-conj M-acc meet-pst-decl

b. Na-nun John-ul kuliko Mary-lul manna-ss-ta (Type B)

I-Top J-acc conj M-acc meet-pst-decl

‘I met John and Mary.’

(14) a. John-kwa Mary-**uy** cakphwum (Type A)

John-conj Mary-Gen work

‘John and Mary’s work’

b. John-**uy** kuliko Mary-**uy** cakphwum (Type B)

John-Gen conj Mary-Gen work

‘John’s and Mary’s work’

By the looks of them, Type A and Type B show a marking asymmetry in terms of case. Specifically, Type A is marked by a (nominal) conjunctive suffix (*-kwa* or *-hako*) on non-final conjuncts. The final conjunct does not carry the conjunctive and is case-marked. In Type B, on the other hand, all conjuncts carry case-markers and the analytic conjunction *kuliko* occurs between the conjuncts. A closer examination, however, reveals not only that the two types are different in their morphosyntax (case-marking forms), but that they differ in their prosody, interpretation, and their syntactic distribution.

2.1 Prosodic Differences⁷

Prosodically, it is predicted that Type B conjunction will be characterized by a pause after the first (case-marked) conjunct, whereas in Type A, a pause is not necessary. Another prediction is that the pause before ‘*kuliko*’ in Type B is longer than the pause after ‘*kuliko*’; that is, the pause observed in the initial conjunct of Type B is not due to the orthographical space, which is observed after ‘*kuliko*’ as well. To see if these predictions are borne out, I conducted a phonetic experiment with the following test sentences exemplified below.

(15)TYPE A and B (examples with **nominative**)

- a. Ann-kwa Gary-ka kohyang-ey ka-ss-ta
 Ann-conj Gary-nom hometown-to go-pst-decl
 Ann-i kuliko Gary-ka kohyang-ey ka-ss-ta
 Ann-nom conj Gary-nom hometown-to go-pst-decl

⁷ This phonetic experimental study on prosody is just preliminary to see if there are prosodic differences between two Types of coordinations. I will need to conduct more experiments with more subjects. In particular, Professor Karlos Arregi advised that I need to measure ‘devoicing’ rather than ‘pause’ before the conjunct. Due to time limitation, I however leave this detailed research on prosody for future studies.

‘Ann and Gary went to hometown.’

- b. Ann-kwa Gary-ka kosi-lul thongkwahay-ss-ta
Ann-conj Gary-nom exam-acc pass-pst-decl
Ann-i kuliko Gary-ka kosi-lul thongkwahay-ss-ta
Ann-nom conj Gary-nom exam-acc pass-pst-decl

‘Ann and Gary passed the exam.’

- c. Ann-kwa Gary-ka kyosil-ey tuleo-ss-ta
Ann-conj Gary-nom classroom-to enter-pst-decl
Ann-i kuliko Gary-ka kyosil-ey tuleo-ss-ta
Ann-nom conj Gary-nom classroom-to enter-pst-decl

‘Ann and Gary entered the classroom.’

- d. Ann-kwa Gary-ka keceyto-lo ttena-ss-ta
Ann-conj Gary-nom keceyto -for leave-pst-decl
Ann-i kuliko Gary-ka keceyto-lo ttena-ss-ta
Ann-nom conj Gary-nom keceyto -for leave-pst-decl

‘Ann and Gary left for Keceyto.’

- e. Ann-kwa Gary-ka kapang-ul sa-ss-ta
Ann-conj Gary-nom bag-acc buy-pst-decl
Ann-i kuliko Gary-ka kapang-ul sa-ss-ta
Ann-nom conj Gary-nom bag -acc buy-pst-decl

‘Ann and Gary bought a bag.’

(16)TYPE A and B (examples with **accusative**)

- a. Younghi-ka Ann-kwa Gary-lul kaluchi-ess-ta
Younghi-nom Ann-conj Gary-acc teach-pst-decl
Younghi-ka Ann-ul kuliko Gary-lul kaluchi-ess-ta
Younghi-nom Ann-acc conj Gary-acc teach-pst-decl
'Younghi taught Ann and Gary.'
- b. Younghi-ka Ann-kwa Gary-lul kochi-ess-ta
Younghi-nom Ann-conj Gary-acc heal-pst-decl
Younghi-ka Ann-ul kuliko Gary-lul kochi-ess-ta
Younghi-nom Ann-acc conj Gary-acc heal-pst-decl
'Younghi healed Ann and Gary.'
- c. Younghi-ka Ann-kwa Gary-lul koyonghay-ss-ta
Younghi-nom Ann-conj Gary-acc employ-pst-decl
Younghi-ka Ann-ul kuliko Gary-lul koyonghay-ss-ta
Younghi-nom Ann-acc conj Gary-acc employ-pst-decl
'Younghi employed Ann and Gary.'
- d. Younghi-ka Ann-kwa Gary-lul kuli-ess-ta
Younghi-nom Ann-conj Gary-acc draw-pst-decl
Younghi-ka Ann-ul kuliko Gary-lul kuli-ess-ta
Younghi-nom Ann-acc conj Gary-acc draw-pst-decl
'Younghi draw (a picture of) Ann and Gary.'
- e. Younghi-ka Ann-kwa Gary-lul koylophi-ess-ta
Younghi-nom Ann-conj Gary-acc bully-pst-decl

Younghi-ka Ann-ul kuliko Gary-lul koylophi-ess-ta

Younghi-nom Ann-acc conj Gary-acc bully-pst-decl

‘Younghi bullied Ann and Gary.’

(17) Type A and B (examples with **genitive**)

a. Chelswu-ka Ann-kwa Gary-uy kulim-ul po-ass-ta

Chelswu-nom Ann-conj Gary-Gen picture-acc see-pst-decl

‘Chelswu saw Ann and Gary’s picture’

Chelswu-ka Ann-uy kuliko Gary-uy kulim-ul po-ass-ta

Chelswu-nom Ann-Gen conj Gary-Gen picture-acc see-pst-decl

‘Chelswu saw Ann’s and Gary’s picture’

b. Chelswu-ka Ann-kwa Gary-uy kohyang-ul pangmwunhay-ss-ta

Chelswu-nom Ann-conj Gary-Gen hometown-acc visit-pst-decl

‘Chelswu visited Ann and Gary’s hometown.’

Chelswu-ka Ann-uy kuliko Gary-uy

Chelswu-nom Ann-Gen conj Gary-Gen

kohyang-ul pangmwunhay-ss-ta

hometown-acc visit-pst-decl

‘Chelswu visited Ann’s and Gary’s hometown.’

c. Chelswu-ka Ann-kwa Gary-uy kwankyey-lul molu-n-ta

Chelswu-nom Ann-conj Gary-Gen relationship-acc be.ignorant-pres-decl

‘Chelswu is ignorant of Ann and Gary’s relationship.’

Chelswu-ka Ann-uy kuliko Gary-uy kwankyey-lul

Chelswu-nom Ann-Gen conj Gary-Gen relationship-acc

molu-n-ta

be.ignorant-pres-decl

‘Chelswu is ignorant of Ann’s and Gary’s relationship.’

d. Chelswu-ka Ann-kwa Gary-uy kapang-ul sa-ss-ta

Chelswu-nom Ann-conj Gary-Gen bag-acc buy-pst-decl

‘Chelswu bought Ann and Gary’s bag.’

Chelswu-ka Ann-uy kuliko Gary-uy kapang-ul sa-ss-ta

Chelswu-nom Ann-Gen conj Gary-Gen bag-acc buy-pst-decl

‘Chelswu bought Ann’s and Gary’s bag.’

e. Chelswu-ka Ann-kwa Gary-uy komin-ul a-n-ta

Chelswu-nom Ann-conj Gary-Gen problem-acc know-pres-decl

‘Chelswu knows Ann and Gary’s problem.’

Chelswu-ka Ann-uy kuliko Gary-uy komin-ul a-n-ta

Chelswu-nom Ann-Gen conj Gary-Gen problem-acc know-pres-decl

‘Chelswu knows Ann’s and Gary’s problem.’

Subjects were given the list of test sentences and were asked to look over the sentences briefly to familiarize themselves with the stimuli. The 30 sentences in Experiment were randomly presented on a computer screen one by one and subjects read them aloud.

To measure the pause durations before and after ‘kwa’ or ‘kuliko’, [1] vowel (sonorant) offset were marked at the end point of high amplitude periodicity in the waveform with reference to formant changes in the spectrogram and [2] the beginning of a stop was marked at the point of stop release.

Below⁸ is one of the representative formants that show the salient differences between the two types; there is no pause after the initial conjunct in Type A, while there is a pause after the initial conjunct in Type B. Furthermore, we measured the length of the pause before and after the conjunctor ‘kuliko’ in type B coordinations to see if the pause observed in the initial conjunct of Type B is not due to the orthographical space.

Figure 1. Pause duration before and after the conjunctor ‘kwa’

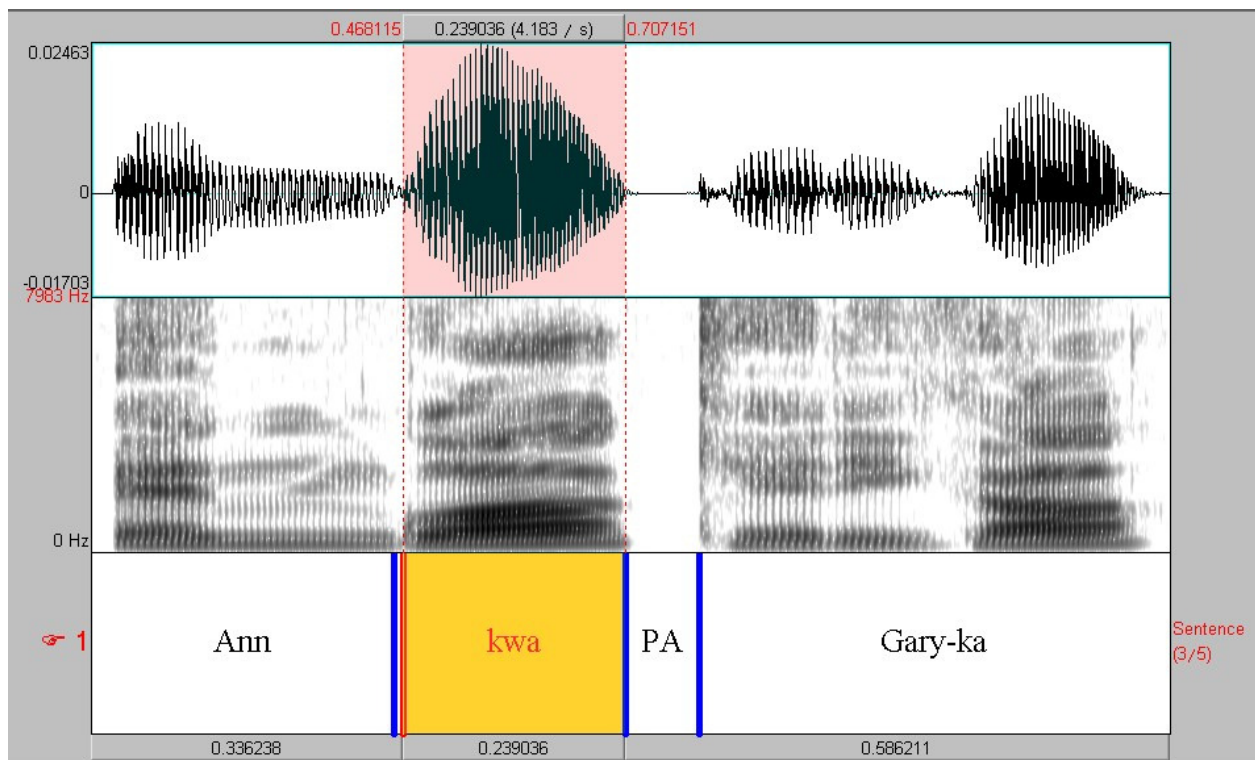

‘Ann-kwa Gary-ka kohyang-ey ka-ss-ta’

⁸ Thanks go to Young-il Oh for helping conducting this phonetic experiment and data analyses.

Figure 2. Pause duration before and after the conjunctor ‘kuliko’

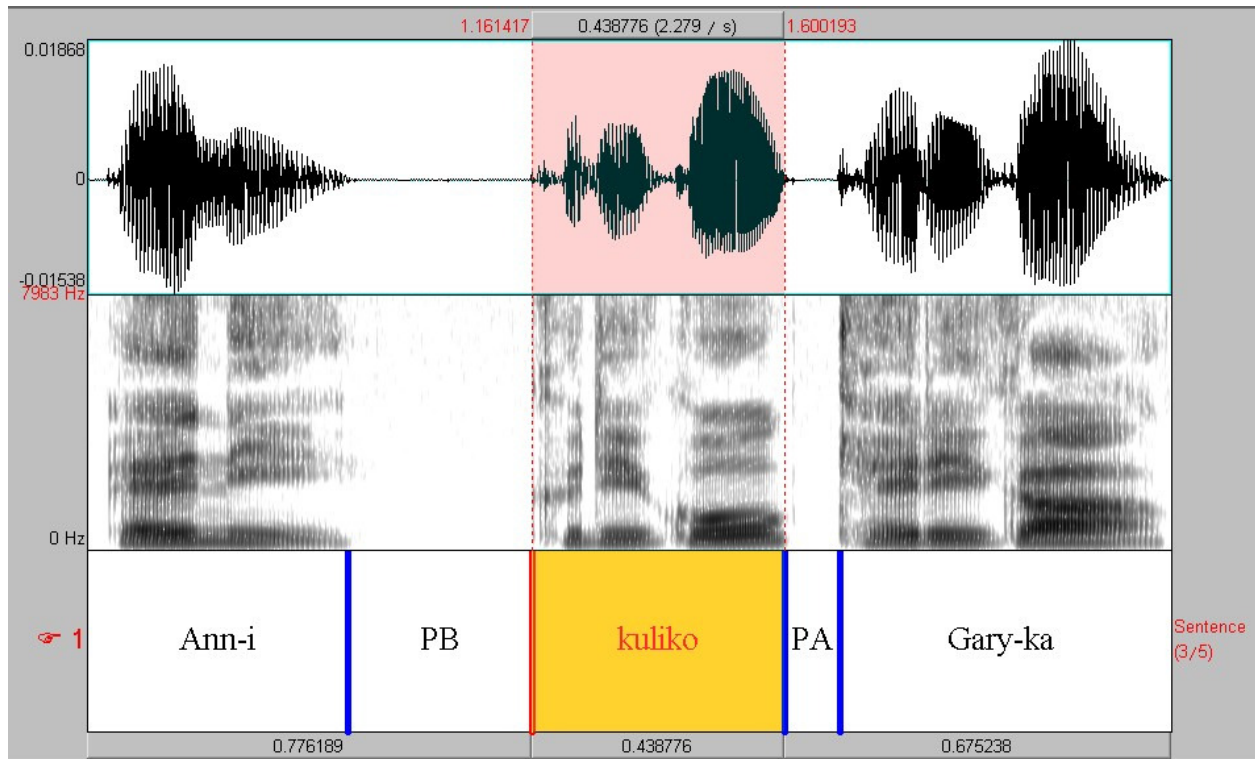

‘Ann-i **kuliko** Gary-ka kohyang-ey ka-ss-ta’

With statistical analysis, the mean value of pre- and post- ‘pause duration’ was coded by subject.

Paired t-test was performed. Table 1 shows results for pause duration.

Table 1. Pause Duration

Subject	Kwa		kuliko	
	PB (ms)	PA (ms)	PB (ms)	PA (ms)
S1	16.49	51.195	56.953	51.352
S2	12.089	52.967	128.745	38.341
S3	13.131	137.851	347.853	124.276
S4	8.516	106.977	151.978	171.147
S5	27.463	60.686	83.271	60.883
Mean	15.5378	81.9352	153.76	89.1998

Figure 3. Pause duration before and after 'kwa'

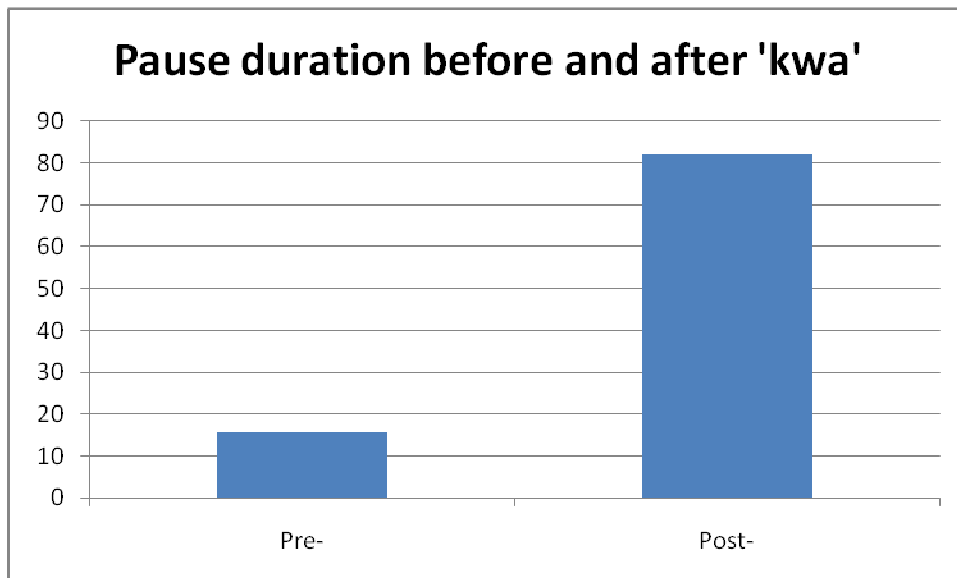

Paired t-test for 'kwa' (two-tailed) shows $t(1,4) = 3.5029$, $p\text{-value} = 0.0248$, where the difference between pre-and post- 'pause duration' is statistically significant.

Figure 4. Pause duration before and after ‘kuliko’

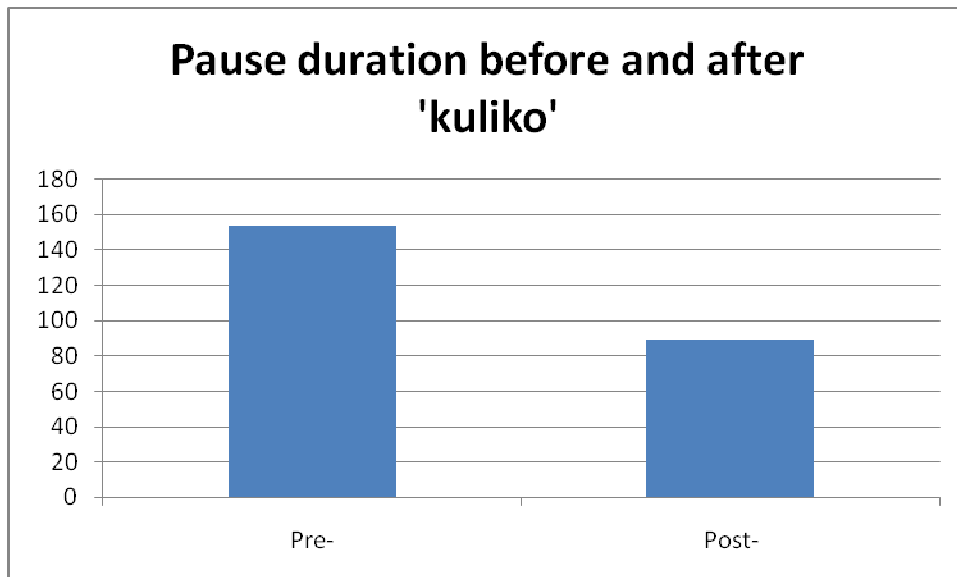

Paired t-test for ‘kuliko’ (two-tailed) shows $t(1,4) = 1.4769$, $p\text{-value} = 0.2138$. Even though the mean value for the pause duration before ‘kuliko’ is longer, the difference between pre- and post- ‘pause duration’ is not statistically significant. We conjecture the value is not significant due to the small number of subjects at this point, but we will keep going on for more subjects.

2.2 Differences in Interpretation

Other than the morphological and prosodic differences we have seen in previous sections, the two types differ interpretively as follows. The example in (18a) denotes a situation where John and Mary could have gone home together or separately, whereas (18b) implies separate events of John and Mary going home. Also, there is a temporal ordering in Type B coordination. Specifically, the event of ‘John having gone home’ happened before that of ‘Mary having gone home’.

(18)a. John-kwa Mary-**ka** cip-ey ka-ss-ta (Type A)
 J-conj M-nom home-loc go-pst-decl

b. John-**i** kuliko Mary-**ka** cip-ey ka-ss-ta (Type B)
 J-nom and M-nom home-loc go-pst-decl

‘John and Mary went home.’

Since the event of ‘one’s going home’ can be distributive, the two readings are not disambiguated clearly. However, in the following cases, the differences become more salient. For example, (19a) is interpreted both in the distributive and the collective sense with the latter reading preferred (Reading #2) by most speakers. (19b), by contrast, draws an unambiguous response as a distributive.

(19)a. John-kwa Mary-ka ochen-pwul-ul pelessta
 J-conj M-nom 5000-dollars-acc made

b. John-**i** kuliko Mary-ka ochen-pwul-ul pelessta
 J-nom conj M-nom 5000-dollars-acc made

#1: John and Mary each made \$5000

#2: John and Mary together made \$5000

(19a): 2 > 1 (19b): 1 only

This holds true also in object conjunctions. For example, (20a) means that John separated water and oil from each other, whereas (20b) has the meaning that John separated water (from something) and that he separated oil (from something).

(20)a. John-i mwul-kwa kilum-**ul** pwunlihay-ss-ta (Type A)

John-nom water-conj oil-acc separate-pst-del

‘John separated water and oil from each other’

b. John-i mwul-**ul** kuliko kilum-**ul** pwunlihay-ssta (Type B)

John-nom water-acc conj oil-acc separate-pst-decl

‘John separated water (from something) and separated oil (from something)’

Differences of the same nature can be found in genitive-marked nominal coordinations as well.

(21a) primarily denotes ‘the mutual relationship between John and Mary’, whereas (21b) denotes two separate relationships of ‘John’s (relationship with someone) and Mary’s relationship with someone.’

(21)a. John-kwa Mary-**uy** kwankyey (Type A)

John-conj Mary-Gen relationship

‘Relationship between John and Mary’

b. John-**uy** kuliko Mary-**uy** kwankyey (Type B)

John-Gen conj Mary-Gen relationship

‘John’s (relationship with someone) and Mary’s relationship with someone’

Thus, regardless of the kinds of case-markers attached (nominative, accusative or genitive), Type A seems to have collective readings as a primary interpretation, while Type B is never interpreted in a collective sense. Thus, one possible way to account for the differences between the two observed so far seems to be to posit that Type A is constituent NP coordination as illustrated

(22a) while Type B is a clausal coordination derived from ellipsis/conjunction reduction of sentential coordination as illustrated in (22b).

(22) a. [_{NP} [NP]-kwa [NP]]-case

b. [_{TP} NP-case ... ~~VP/NP~~] kuliko [_{TP} NP-case VP/NP]

Specifically, under the analysis, where Type B is considered to have been reduced from two full sentences as illustrated in (b) examples of (23-25), the distributive reading is correctly predicted because the presence of the predicate in the initial conjunct makes it impossible for the two case-marked NPs to be construed together, banning the potential collective reading.

(23)a. John-kwa Mary-**ka** ochen-pwul-ul pelessta
 J-conj M-nom 5000-dollars-acc made

b. John-**i** ~~ochen-pwul-ul~~ — ~~pelessta~~ — kuliko
 J-nom 5000-\$-acc made conj
 Mary-**ka** ochen-pwul-ul pelessta
 M-nom 5000-dollars-acc made

‘John and Mary each made \$5000.’

(24)a. John-i mwul-kwa kilum-**ul** pwunlihay-ss-ta
 J-nom water-conj oil-acc separate-pst-del

‘John separated water and oil from each other’

b. John-i mwul-**ul** ~~pwunlihay-ss-ta~~ kuliko kilum-**ul** pwunlihay-ss-ta
 J-nom water-acc separate-pst-decl conj oil-acc separate-pst-decl

‘John separated water (from something) and separated oil (from something)’

(25)a. John-kwa Mary-**uy** kwankyey (Type A)

John-conj Mary-Gen relationship

‘Relationship between John and Mary’

b. John-**uy** ~~kwankyey~~ kuliko Mary-**uy** kwankyey (Type B)

John-Gen relationship conj Mary-Gen relationship

‘John’s (relationship with someone) and Mary’s relationship with someone’

2.3 Syntactic Differences: Clear, but Hard to Explain

Based on the differences in interpretation of the two Types, I conjectured that Type A seems to be a form of constituent NP coordination while Type B a form of clausal coordination derived through conjunction reduction of sentential coordination. Thus, this syntactic analysis is based on the semantic facts so far.

If it is true that Type A is a coordinated plural NP and that Type B is an elliptical form of a larger sentence (form), it is predicted that Type A allows collective predicates while Type B does not. In other words, as Type A involves a single event, it is predicted to allow collective predicates. Type B, however, involves two separate events, so it is predicted to disallow collective predicates. It further predicts that Type A has a standard NP distribution while Type B does not. Now we shall consider whether this prediction is borne out.

First, Type A coordinations are predicted to allow collective predicates as it involves a single event, and the prediction is borne out, as we see in the (a)-examples of (26-27). By contrast, Type B coordinations are predicted to disallow collective predicates as it involves two separate events, and the prediction is confirmed as we see in the (b)-examples of (26-27).

Collective Predicates:

- (26) a. Cheli-wa Yenghi-ka pwupwu-ya
C-conj Y-nom couple-cop.decl
b. *Cheli-ka kuliko Yenghi-ka pwupwu-ya
C-nom conj Y-nom couple-cop.decl
'Cheli and Yenghi are a couple.'

- (27) a. Cheli-wa Yenghi-ka heyeci-ess-ta
C-conj Y-nom break.up-pst-decl
b. *Cheli-ka kuliko Yenghi-ka heyeci-ess-ta
C-nom conj Y-nom break.up-pst-decl
'Cheli and Yenghi broke up.'

Second, Type A is predicted not to allow adverb insertion between the conjuncts since adverbs cannot modify NPs, while Type B is predicted to allow adverb insertion as the initial conjunct is suspected to be a reduced form of a sentence. This prediction is borne out as shown in (28a-b).

- (28)*a. Cheli-wa himtulkey Yenghi-ka **swipkey** il-ul ha-nta
C-conj with.difficulty Y-nom easily work-Acc do-decl
'Cheli and Yenghi do the work with a lot of effort.'
b. C-ka himtulkey kuliko Y-ka swipkey il-ul hanta
C-nom with.difficulty conj Y-nom easily work-Acc do-decl
'Cheli does the work with difficulty and/but Yenghi does the work with ease.'

Third, Type A is predicted to be the focus of cleft whereas Type B is not. The focus of the cleft should always be NP due to the fact that it is a complement of copula *-ita*. This prediction is borne out as in (29).

- (29) a. Il-ul swipkey hanun kes-un **C-wa** **Y-i-ta**
 work-acc easily do.rel thing-nom C-conj Y-cop-decl
- b. * Il-ul swipkey hanun kes-un **C-ka** **kuliko** **Y-(ka)-i-ta**
 work-acc easily do.rel thing-nom C-nom conj Y-cop-decl
- ‘It is Cheli and Yenghi who do the work with no effort.’

Type A and B also behave differently with reference to disjunction and negation (Han and Romero 2004). (30a) has yes/no reading ‘Is it true or not that C drank coffee or tea?’ (yes/no question) However, (30b) has alternative reading ‘Did C drink coffee or did he drink tea?’ (choice question). In non-WH questions in Korean, yes/no question arises when there is a single Q-marker *-ni* in a sentence. Alternative/Choice question arises when there are two Q-markers involved in a sentence. Now, the difference in (30a-b) is attributed to the fact that the latter is derived by Ellipsis from a clausal disjunction, whereas the former is not. To be specific, in (30a), the disjunctive NP phrase ‘kophi-na cha’ is under the scope of a single yes/no Q-marker, so, this can be a yes/no question. However, (30b) has the reading ‘Did C drink coffee or he did drink tea?’, which means that there are two Q-markers involved in this construction, one of which has undergone ellipsis. So, the pre-elliptical form would be ‘Cheli-ka kophi-lul masi-ess-ni, animyen cha-lul masi-ess-ni?’, yielding alternative/choice question only.

- (30) a. Chelswu-ka kophi-na cha-lul masi-ess-ni?
 C-nom coffee-or tea-acc drink-pst-Q
- b. Chelswu-ka kophi-lul animyen cha-lul masi-ess-ni?
 C-nom coffee-acc or tea-acc drink-pst-Q

We have conjectured that Type B is derived from a sentential conjunction and tested several predictions based on the conjecture. As all the predictions are borne out, the primary conclusion is that Type A is a constituent NP coordination whereas Type B is a reduced form from a larger/sentential coordination. This interim conclusion, however, will be reconsidered in the next section based on some problematic examples with this reduction analysis.

Before we leave this section, we can ask why there is no constituent coordination of NPs in Korean where each conjunct is marked with case. The answer would be that there is a very special role that is played by case in Korean, in light of the fact that in other languages (German) this is not the case. -- i.e., when we have ‘verbal’ case-markers, then a ‘verbal’ constituent must follow it combinatorically, and that is why the two types of coordinations differ the way they do.

3. Need for an Alternative Analysis

In the previous section, we hypothesized that, unlike Type A coordination, Type B coordination is a reduced form from a larger/sentential coordination. This hypothesis seemed to be supported by many pieces of evidence involving collective predicates, clefting, adverb insertion and disjunction. Thus, the tentative conclusion was that Type B coordination is a sentential conjunction that underwent ellipsis at some point of derivation. The following data, however, challenge this preliminary conclusion. There are in fact Type B coordinations which allow

Relational Modifiers (RM) like ‘kakkak’ as in (31) and Dummy Plural Marker (DPM) ‘tul’ as in (32). This betrays our expectation because our observation so far suggested that Type B is an elliptical conjunction from a larger sentence. Specifically, if we do an ellipsis analysis as in (b)-examples of (31-32), the sentence is not acceptable. As RM and DPM require plural subjects as their licensors, the singular subject in each conjunct is not supposed to allow Relational Modifiers or Dummy Plural Markers, which are modifiers of plural events or entities.

RM ‘kakkak’

(31)a. Cheli-ka ecey kuliko Yenghi-ka onul **kakkak** ttenassta
 C-nom yesterday conj Y-nom today each left
 ‘C left yesterday and Y left today respectively’

b. * Cheli-ka ecey ~~kakkak~~ ~~ttenassta~~ kuliko
 Yenghi-ka onul **kakkak** ttenassta

DPM ‘-tul’

(32) a. Cheli-ka kuliko Yenghui-ka chayk-ul cal-**tul** ilk-ess-ta
 C-nom conj Y-nom book-acc well-DPM read-past-decl
 ‘Cheli and Yenghui read a book well.’

b. * Cheli-ka ~~chayk-ul~~ ~~cal-**tul**~~ ~~ilk-ess-ta~~
 kuliko Yenghui-ka chayk-ul cal-**tul** ilk-ess-ta

These data challenge the provisional analysis discussed so far and necessitate an alternative analysis. Before we proceed to the next section, we summarize the major discussion of this section as follows.

- Type B coordinations do not have NP distribution syntactically.
- Type B coordinations differ interpretively from Type A coordinations.
- Lexically collective predicates cannot occur in Type B coordinations.
- Relational modifiers and Dummy Plural Markers appear to be compatible with Type B coordinations.
- Relational modifiers and Dummy Plural Markers must be in the shared predicate of Type B coordinations.

These observations on the systematic differences between Type A and B coordinations were first made in Yoon and Lee (2005), but the properties of the two coordinations could not be satisfactorily accounted for (by a single analysis). Section 4 proposes an alternative analysis, which we call the “Incremental C-selectional Combinatoric Analysis” that can account for various properties of Type B Constructions. We will provide analyses that explain the contrastive properties between Type A and B Coordinations. The analysis of Type B constructions, however, will be more elaborated in Chapter 3, where the analysis will be extended to Right Node Raising constructions, which shows exactly the same properties as Type B coordinations in syntactic terms, in the sense that those two constructions are clausal conjunctions with a null predicate in the initial conjunct.

4. An Alternative Analysis: the Incremental C-selectional Combinatoric Analysis

Other than empirical backgrounds presented in the previous sections, the theoretical backgrounds of an alternative analysis proposed in this dissertation were discussed in detail in Chapter 1. Specifically, I propose a Incremental C-selectional Combinatoric Analysis, based on following studies; [1] Combinatory Categorical Grammar (Steedman 1982, 1985, 1990, Dowty 1988) where arguments, as a functor, combine with a predicate [2] Yu-Cho and Sells (1995), where combinatoric markers have some feature specifications such as [TYPE: N-SIS] and [TYPE: V-SIS] and help arguments find a compatible sister to combine with [3] Y-J Choi (2007)'s dependent marking parameter, where arguments combine with each other and then select a compatible predicate [4] Philips' (2003) incremental structure building analysis that sentence structures are built incrementally from left to right.

Even though the observation of the systematic differences between Type A and B coordinations was initially the motivation⁹ for a new system, this system is not proposed just for the differentiation of Type A and Type B coordinations in Korean – I will show that it accounts for various other constructions including Right Node Raising (RNR) Constructions, Coordination under Right Node Raising (CoRNR) constructions, Right-Dislocation Constructions. In doing so, we also examine how the null arguments or the null predicates are semantically and syntactically resolved in each construction under the proposed system.

4.1 How it works

4.1.1 The feature specification of case-phrase (KP) and verb phrase (VP)

We take case-marked NPs in Korean to be syntactic functors which select another case-marked

⁹ Choi (2008) also showed that case markers play crucial roles accounting for various other constructions in Korean – Fragments, Clefting and Argument Cluster Coordinations.

nominal (KP = case phrase) or a compatible predicate (VP) as its argument. Putting an emphasis on the role of case-markers, we propose each case-marker has the following feature specification [1]-[4] that makes it possible for it to combine with other DP or KP or VP. As the case-markers help arguments combine with each other or with predicates, I will call them combinatory markers (Yu-Cho and Sells 1995 cf. *Dependent Markers*; Y-J Choi 2007). Other than case-markers, there are other elements that help adjectives or clauses combine with other elements (NPs etc). I call these elements combinatory markers, which include Adjectivizer (ADJ), Complementizer (COMP), Conjunctive (CONJ), Determiner (DET) and Relativizer (REL), etc. We will discuss the feature specifications of these combinatory markers as well as how they work in clause structure building (4.1.3 – 4.1.5). Other than the combinatory markers, verbs also have the feature specifications as in [5]. As this is unconventional under many theories, an explanation of the terms is in order.

K(P) stands for a case-phrase. K_{NOM} in Korean is the nominative case-marker *-il/ka*, K_{DAT} , the dative case-marker *-eykey*, K_{ACC} , the accusative case marker *-ullul*, K_{GEN} , the genitive case-marker *-uy*. PHON means a phonetic feature/sound and CAT, a category/part of speech. C-SEL shows combinatory selection and S-SEL, semantic selection. We assume that verbs do not C-select (combinatory selection), but only S-select (semantic selection) arguments. The number of arguments that verbs *S-select* depends on their verb classes. Under PROBE, it has unspecified V1-V7 as a value of verbal specification. Generally put, the specification for case-markers (K) in [1-4] says that K C-selects a D(P) to its left and either a K(P) or V(P) to its right. To ensure that the right class of V(P) occurs with a given KP, I posit that K has an ‘uninterpretable’ V-CLASS feature, which requires that K ‘Agree’ with the V that heads the VP that is selected by it (or by the K of the KP that it combines with) in terms of the V-CLASS feature. Since a given K is

compatible with more than one valence class, the specification of V-CLASS is disjunctive (Shieber 1986).

[1] Nominative Case-marker (K_{NOM})

PHON: /ka/
CAT: K_{NOM}
C-SEL: $\langle D, K \vee V \rangle$
PROBE: V-CL:
 { uV1
 uV2
 uV3
 uV4
 uV5
 uV6
 uV7 }

[2] Accusative Case-marker (K_{ACC})

PHON: /lu/
CAT: K_{ACC}
C-SEL: $\langle D, K \vee V \rangle$
PROBE: V-CL:
 { uV2
 uV4 }

[3] Dative Case-marker (K_{DAT})

PHON: /eykey/
CAT: K_{DAT}
C-SEL: $\langle D, K \vee V \rangle$
PROBE: V-CL:
 { uV3 }
 { uV4 }
 { uV6 }

[4] Genitive Case-marker (K_{GEN})

PHON: /uy/
CAT: K_{GEN}
C-SEL: $\langle D, D \rangle$
PROBE: _____

[5] Verb

Vn:

CAT: /verb/
V-CL: iV_n
S-SEL: $\langle D, (D, D\dots) \rangle$

Before we move on to the next sub-section 4.1.2, let me briefly discuss syntactic structure well-formedness under the proposed system. As we see in the feature specification of the verb, verbs only semantically select arguments. Crucially, in this system, arguments syntactically select the predicate, but not vice versa, so that the predicate does not need to discharge all its theta roles to its overt arguments. So, a verb by itself is a well-formed sentence, and does not require overtly

expressed arguments¹⁰. On the other hand, Case-marked NPs by themselves, i.e., when they are not followed by the predicate, are elliptical forms. That is, “argument” fragments are elliptical, while predicates alone can make a well-formed sentence and are not elliptical. So, even if one of the verb’s (semantic) arguments drops, we do not need to posit a *pro* for the gap since the sentence is well-formed as long as a single overt argument is of the right type to combine with a given verb. Adjuncts can freely adjoin to both nominative and accusative case-marked NPs or verbs since, under the proposed system, case-marked NPs (that is, KPs) are basically the same as VPs, which makes adjuncts adjoin to KPs and VPs without a problem.

4.1.2 The classification of verbs

In the proposed system, verbs are classified into different valence classes¹¹ (cf. Canonical Sentence Perspective of S-Y Kuroda). Seven such classes are illustrated below (33) (V1-V9), but there may be more classes since these are just illustrative classes of verbs classified in terms of their syntactic valence.

(33)a. *Cheli-ka* Δ

Cheli-nom

Δ : Class 1 (*kata* ‘go’, *ota* ‘come’, *wulta* ‘cry’, *khika khuta* ‘is tall’ etc.)

¹⁰ Of course, the verb still carries its semantic arguments under its feature structure, which do not need to be overtly realized.

¹¹ One might ask what is the difference between saying that verbs have subcategorization and classifying them according to subcategorization class. One way to avoid the duplication is to take Kuroda’s Canonical Sentence Perspective seriously, and think of the KP (clusters) plus the VP as defining a constructional template in the manner of constructional grammar.

If we do that, then there is no duplication. I.e., Class 1 is the template consisting of KP and VP (where KP is headed by Nom), while Class 2 is a template with two KPs and VP (where the KPs are Nom and Acc).

b. Cheli-*ka* sakwa-*lul* Δ

Cheli-nom apple-acc

Δ: Class 2 (coahata ‘like’, caluta ‘cut’, mekta ‘eat’ etc.) (or Class 4)

c. Cheli-*ka* Yenghi-*eykey* Δ

Cheli-nom Yenghi-dat

Δ: Class 3 (insahata ‘greet’ etc.) (or Class 4)

d. Cheli-*ka* Yenghi-*eykey* sakwa-*lul* Δ

Cheli-nom Yenghi-dat apple-acc

Δ: Class 4 (ponayta ‘send’, cwuta ‘give’ etc.)

e. Cheli-*ka* [Yenghi-*ka* yepputa]-*ko* Δ

Cheli-nom Yenghi-acc be.pretty-COMP

Δ: Class 5 (sayngkakhata ‘think’ etc.) (or Class 6)

f. Cheli-*ka* [Yenghi-*ka* sakwa-*lul* cohahanta]-*ko* Tongswu-*eykey* Δ

Cheli-nom Yenghi-nom apple-acc like-COMP Tongswu-dat

Δ: Class 6 (malhata ‘tell’ etc.)

g. Cheli-*ka* ton-*i* Δ

Cheli-nom money-nom

Δ: Class 7 (philyohata ‘need’, kulipta ‘miss’ etc.)

h: Cheli-ka kwail-ul (Kacc Kacc Kacc...) Δ
Cheli-nom Fruit-acc

Δ: Class 8 (*sakwa-lul* *cohadata* ‘like apples.’ etc.)

i: Cheli-ka (Knom Knom Knom...) Δ
Cheli-nom

Δ: Class 9 (*khi-ka* *khu-ta* ‘is tall’ etc.)

Class 8 and Class 9 are needed specifically for Multiple Accusative and Multiple Nominative Constructions¹² respectively. In multiple accusative constructions, the accusative NP is followed by phrasal transitives and in multiple nominative constructions, the nominative NP takes phrasal intransitives.

4.1.3 How the arguments combine

This sub-section shows how the arguments combine with the help of the feature specification of each case-marker and how the combined arguments, as a whole, correctly select verbs of the right class. Specifically, as illustrated in (34a-b), case-marked arguments combine with each other (cf. ‘argument adjunction’ of Saito 1994 and Takano 2003) and select a compatible predicate, rather than vice versa (Whitman 1998, Koga 2000, Fukushima 2003, Y-J Choi 2007). Thus, we take the difference between languages like Korean (heavily dependent-marking, in Nichol’s 1986 sense) and others to be such that K (or KP) can be a probe (by virtue of its case feature). It probes into its c-command domain to look for another KP or a compatible predicate.

¹² As the issues revolving these constructions are quite complicated, I will leave the analysis of these for future research.

(34) a.

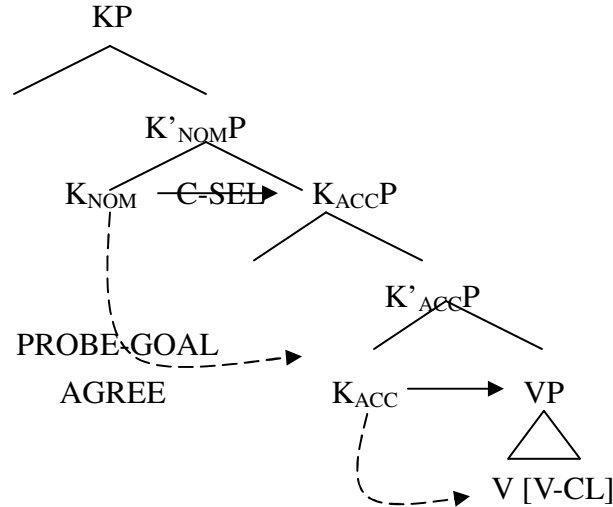

b.

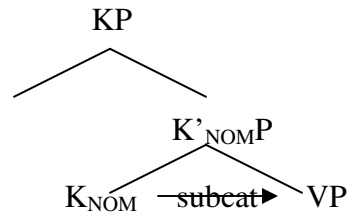

The arguments combine in the manner of Phillips' (2003) Incrementality Hypothesis, namely that sentence structures are built incrementally from left to right. A KP or a KP cluster under the proposed system combines strictly left to right (Kempson et al. 2001, Phillips 2003, Y-J Choi 2007, among others) and then selects a compatible predicate. "Compatibility" is determined based on the feature specification of the case-markers of the argument clusters, the verb classification based on each verb's case array and the semantic selection of the verb. When there is no compatible predicate available, an empty predicate [e] is licensed whose content is to be resolved later when a compatible, overt one is encountered. The licensing of an empty predicate [e] thus motivates a following KP to open a new clause because null predicate licensing¹³ occurs when a KP cannot directly combine with an immediately following KP.

¹³ The nominative KP, for example, licenses a null predicate when it cannot combine with the following predicate as they are separated by conjunctors such as 'kuliko', which hinders/delays the KP's search for the predicate. Or, the nominative KP's licensing a null predicate arises when another nominative KP follows the nominative KP, except for multiple nominative constructions.

An empty predicate, however, is licensed as sparingly as possible and is to be resolved as soon as possible throughout the derivation. That is, the first condition “As Sparingly As Possible” is due to the fact that a nominative KP does not license a null predicate just because it cannot find a predicate immediately after that nominative KP. It tries to combine with the following accusative or dative KP, if any. Thus, null predicate licensing is a last resort operation to save the derivation from crashing. In cases that even this ‘null predicate licensing’ operation does not help, derivation crashes, resulting in ungrammaticality. The second condition “As Soon as Possible” means that any overt predicates, in the order they appear, can be a candidate with which the null predicate can be co-indexed to retrieve its contents. The first coming predicate is taken to be a candidate for providing the contents for the null predicate. If there is no problem in terms of c-selection or semantic roles etc, the null predicate is immediately resolved by co-indexation. However, if there arises a problem in regard to c-selection or semantic roles, co-indexation does not occur, waiting for the next overt predicate to appear.

A brief note on the resolution of the contents of the null predicate is in order. The null predicate is resolved in a cataphoric manner within a sentence for some obvious reasons; the contents of the null predicate are retrieved when an overt predicate is parsed at a later point in derivation. So, within a single sentence, the null predicate is cataphorically resolved. On the other hand, the contents of the null predicate is anaphorically resolved when the null predicate appears outside a sentence as observed in constructions such as Fragments (See Y-J Choi 2008) and Right Dislocations (See Chapter 4 for detailed discussion).

Now, let us take a look at how the arguments find a predicate of the right class. As we have seen in subsection 4.1.1, a nominative case-marker has the following specification.

Nominative Case-marker (K_{NOM}):

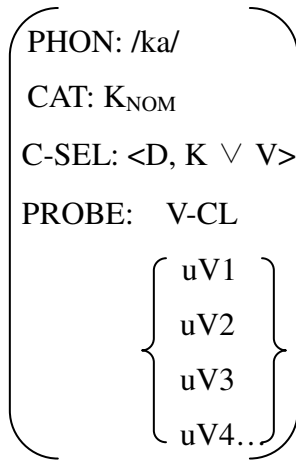

Then, this Nom-marked DP looks for a range of predicates (V1, V2, V3, V4...) as shown in (35). Once it combines with an ACC-marked DP, the type of predicates the clusters search is restricted (now, V2, V4), due to information added by the ACC-marker (Choi and Yoon 2006).

- (35) Cheli-**ka** V1, V2, V3, V4...
 Yenghi-**lul** V2, V4...
 : Cheli-**ka** Yenghi-**lul** V2, V4

Likewise, when this Nom-marked DP combines with a DAT-marked DP as in (36), the type of predicates the clusters search is narrowed down to V3, V4, V6. If the clusters further combine with CP, the only available V-Class is V6.

- (36) Cheli-**ka** V1, V2, V3, V4, V5, V6, V7
 Yenghi-**eykey** V3, V4, V6
 [Tongswu-ka catongcha-lul sa-ss-ta]-**ko** V6

: Cheli-ka Yenghi-eykey [Tongswu-ka catongcha-lul sa-ss-ta]-ko V6

4.1.4 Derivation of Simple Sentences

Now let us take a look at a simple derivation with a fragment of Korean grammar.

(37) *Yenghi-ka Mary-lul manna-ss-ta*
Y-nom M-acc meet-pst-decl
'Yenghi met Mary'

a. Select D; Project DP:

[*Yenghi*]_{DP}

b. Select K, Merge(K, DP):¹⁴

[*Yenghi-ka*]_{KP}

c. Select D; Project DP:

[*Mary*]_{DP}

d. Select K, Merge(K, DP):

[*Mary-lul*]_{KP}

¹⁴ We take Merge to be asymmetric. In Merge (a,b), a projects and labels the constituent. Merge is constrained by C-SEL(ection), as we shall see.

e. Merge (K, KP):

[*Yenghi-ka Mary-lul* V2, V4...]_{KP}

f. Select V; Project VP:

[*manna*(V2)-]_{VP}

g. Merge(K, VP):

[*Yenghi-ka Mary-lul manna*(V2)-]_{KP}

h. Select T; Merge(T, KP); Select M; Merge(M, TP):

[[*Yenghi-ka Mary-lul manna*-]_{KP-ss}]_{TP-ta}]_{MP}

(38)

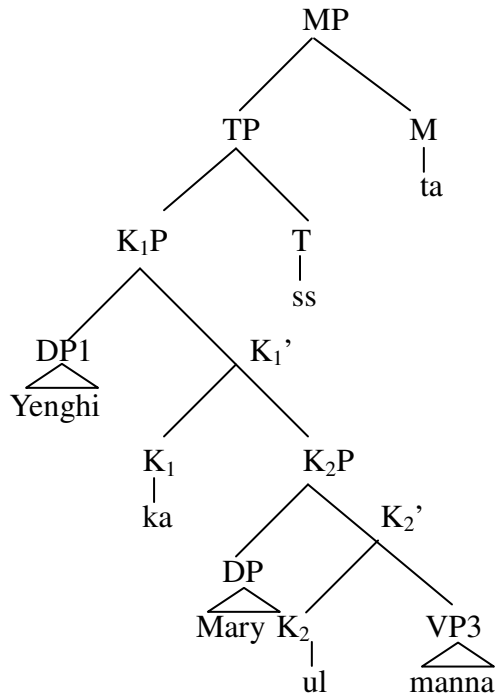

K1:

PHON: /ka/
CAT: K_{NOM}
C-SEL: <D, K ∨ V>
PROBE: V-CL:
 { uV1 }
 { uV2 }
 { uV3 }
 { uV4... }

K2:

PHON: /lul/
CAT: K_{ACC}
C-SEL: <D, K ∨ V>
PROBE: V-CL:
 { uV2 }
 { uV4 }

V2:

CAT: /manna-/
V-CL: iV2
S-SEL: <D, D>

Local scrambling is base-generated in this system. Example sentence (39) is derived in a similar fashion except for the order of KPs.

- (39) Yenghi-lul Mary-ka manna-ss-ta
Y-acc M-nom meet-pst-decl
'Mary met Yenghi'

a. Select D; Project DP:

[*Yenghi*]_{DP}

b. Select K; Merge (K, DP)

[*Yenghi-lul*]_{KP}

c. Select D; Project DP

[*Mary*]_{DP}

d. Select K; Merge (K, DP)

[*Mary-ka*]_{KP}

e. Merge (K, KP):

[*Yenghi-lul Mary-ka V2, V3...*]_{KP}

f. Select V; Project VP

[*manna (V2)*]_{VP}

g. Merge (K, VP)

[*Yenghi-lul Mary-ka manna(V2)-*]_{KP}

h. Select T; Merge(T, KP); Select M; Merge(M, TP):

[[[*Mary-lul Yenghi-ka manna-*]_{KP-ss}]_{TP-ta}]_{MP}

The structure of (40) would be exactly the same as (38) except that the two KPs are in a reverse order.

Now, we consider other examples involving embedded NPs such as *ku pissa-n chayk* (the expensive book), *Yenghi-uy kapang* (Yenghi's bag), *Yenghi-uy nalk-un kapang* (an old bag of Yenghi's). For the derivation of NPs with an embedded clause, we need additional combinatoric markers -- Adjectivizer (ADJ) *-n* and Determiner (DET) *-i, ku*.

Two additional combinatoric markers for clauses with embedded NPs again:

Adjectivizer (ADJ) *-n*

ADJ:

PHON: /n/
CAT: ADJ
C-SEL: <A, D >
PROBE: _____

Determiner (DET) *-i, ku*

DET:

PHON: /ku/
CAT: DET
C-SEL: <∅, N>
PROBE: _____

Now, let us consider how other combinatory markers help build sentences. Example (41) is formed with the help of combinatoric markers such as K, DET and ADJ as depicted below. Each combinatory marker, according to its feature specification, takes the following element as its

sister as long as the element has the right syntactic category specified under the feature structure of the combinatory marker. If two adjacent elements cannot directly combine, a null noun or a null predicate is licensed, whose contents are resolved when an overt, compatible one is encountered.

(41) Cheli-ka ku pissa-n chayk-ul ccic-ess-ta
 C-mom the expensive-ADJ book-acc tear.away-pst-decl
 Cheli tore the expensive book away.'

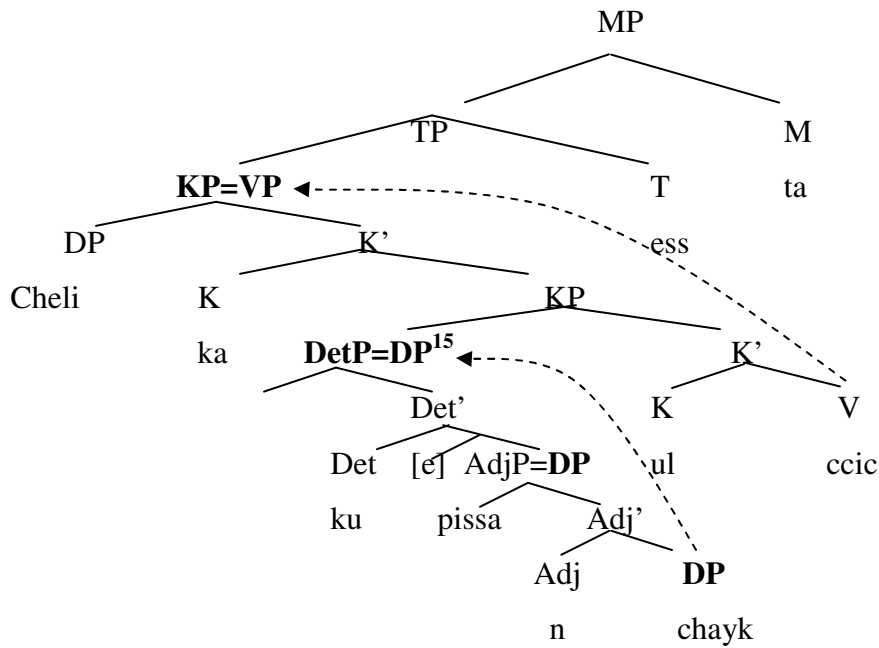

Other similar examples are displayed in (42-43) below.

¹⁵ Not being lexical items, combinatoric markers such as 'K', 'Det' and 'Adj' help lexical items to combine with each other. Thus, to see exactly what lexical phrases they are, we refer to the rightmost element/daughter of the relevant combinatoric phrases (DetPs, KPs, CPs and RPs). The lexical feature (Noun, Verb etc.) of the rightmost element goes/percolates all the way up to the combinatoric phrases and determines their lexical categories as depicted with a dotted line in 41.

(42)Cheli-ka Yenghi-uy kapang-ul ppayass-ass-ta

C-nom Y-gen bag-acc take-pst-decl

Cheli took Yenghi's bag.'

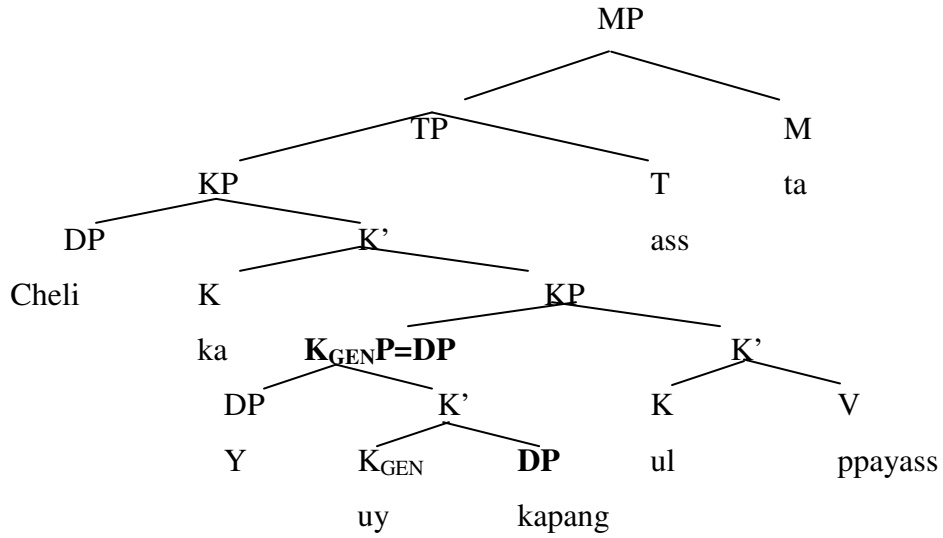

(43)Cheli-ka Yenghi-uy nalk-un kapang-ul ppayass-ass-ta

C-nom Y-gen old-Adj bag-acc take-pst-decl

Cheli took an old bag of Yenghi's.'

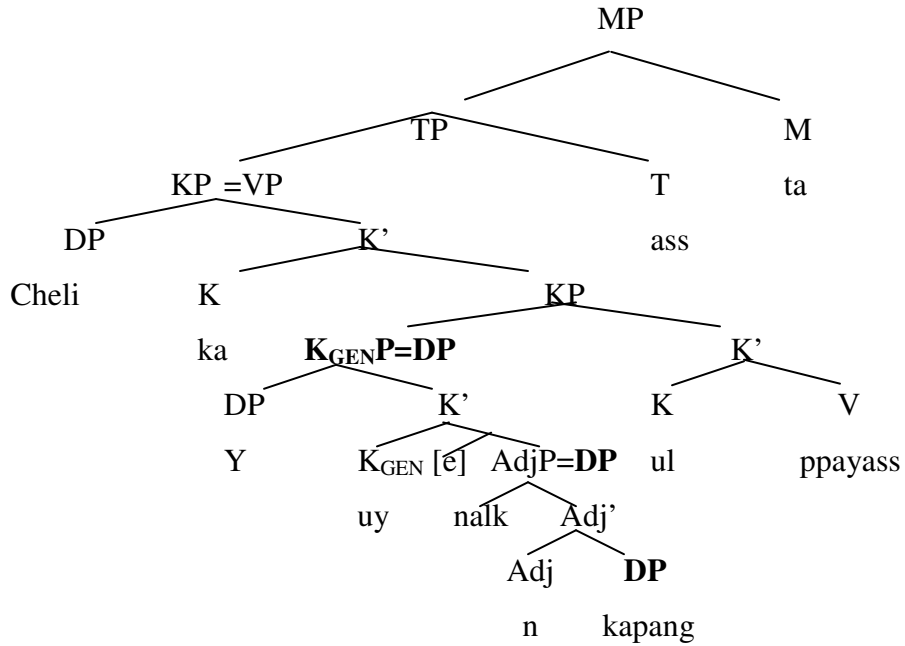

Other than these combinatoric markers proposed so far, we have conjunctive/disjunctive markers *-wa, -hako, -lang*.

Conjunctive/Disjunctive Combinatoric Markers:

Conjunctive (Conj) *-wa, -hako, -lang*

CONJ:

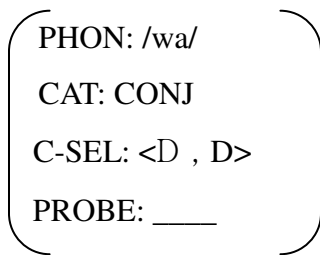

Conjunctive (Conj) *-kuliko*

CONJ:

PHON: /kuliko/
CAT: CONJ
C-SEL: <K ∨ V, K ∨ V >
PROBE: _____

Conjunctive (Conj) *-ko*

CONJ:

PHON: /ko/
CAT: CONJ
C-SEL: <A ∨ V, A ∨ V >
PROBE: _____

Disjunctive (Disj) *-na*

DISJ:

PHON: /na/
CAT: DISJ
C-SEL: <D, D>
PROBE: _____

With these we can derive (44) as illustrated in (45).

(44)Cheli-na Yenghi-ka Beethoven-kwa Mozart-lul coaha-n-ta

Cheli-or Y-nom B-conj M-acc like-pres-decl

‘Cheli or Yenghi likes Beethoven and Mozart.’

(45)

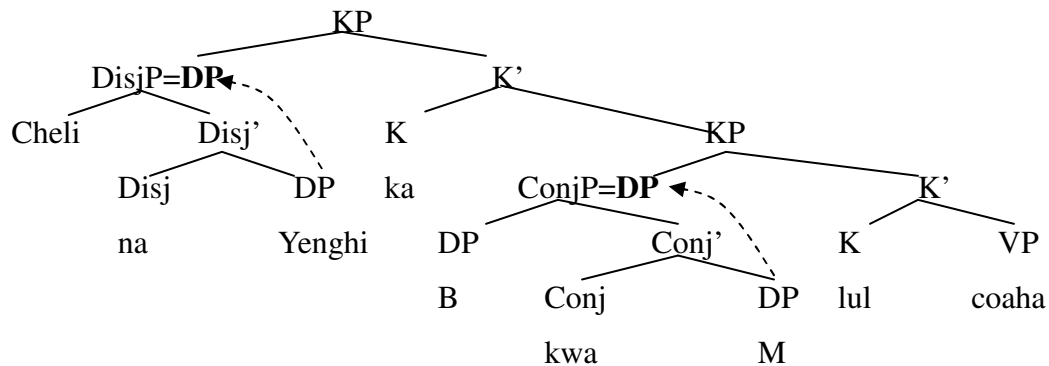

So far we have considered how simple sentences can be derived under the proposed analysis. Before dealing with more complicated examples, I will provide an analysis of Type A and Type B Coordinations.

4.2 The Incremental C-selectional Combinatoric Analysis of Type A and Type B Coordinations

As we have discussed how the proposed system works in general, let us now turn to how the analysis accounts for the properties of two types of Coordinations. Type A vs. B Coordinations are re-introduced in (46-48) below. The main contrastive properties that need be accounted for in this Chapter include:

- Type B coordinations do not have NP distribution syntactically.
- Type B coordinations differ interpretively from Type A coordinations.
- Certain collective predicates and (collective modifiers) cannot occur in Type B coordinations.

Let us first take a look at how Type A and B with nominative case-markers can be accounted for under the proposed system. Type A is analyzed as in (46a), where the initial conjunct does not have its own predicate, while Type B is analyzed as in (46b), where the initial conjunct has a predicate.

(46)a. John-kwa Mary-**ka** cip-ey ka-ss-ta (Type A)

J-conj M-nom home-loc go-pst-decl

b. John-**i** kuliko Mary-**ka** cip-ey ka-ss-ta (Type B)

J-nom and M-nom home-loc go-pst-decl

‘John and Mary went home.’

a. Type A

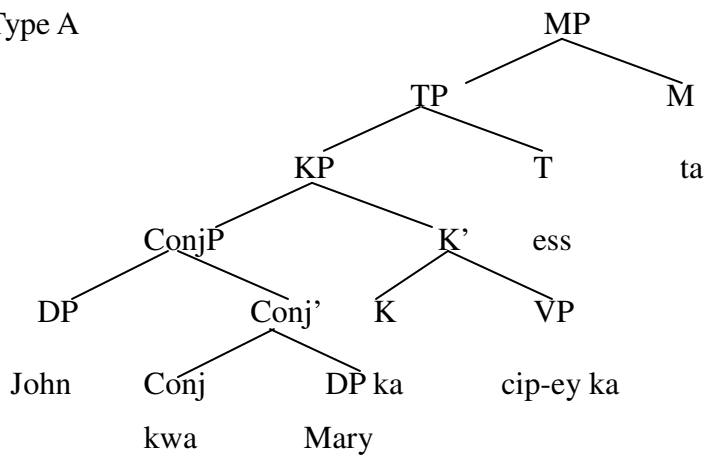

b. Type B

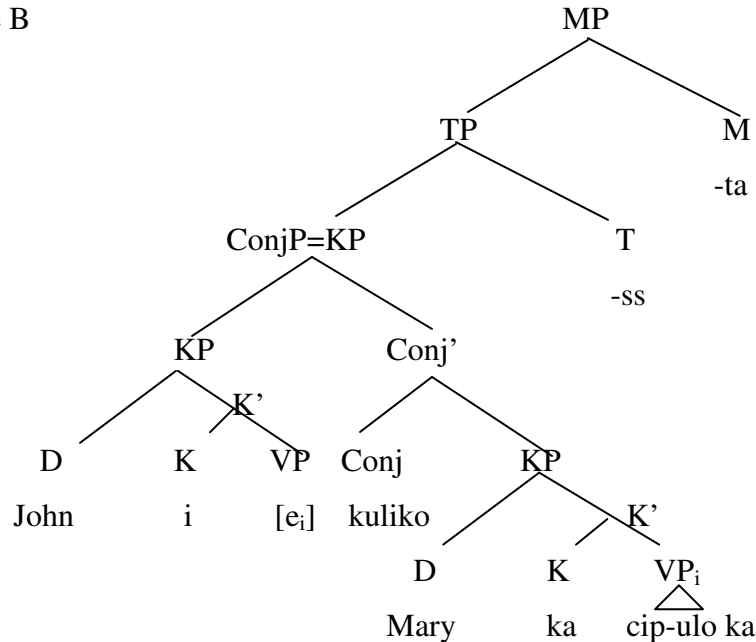

Comparison of the structures of the two types of coordinations shows why they behave the way they do. Specifically, as shown in the structures, Type B coordinations are not NP Coordinations and accordingly do not exhibit NP distribution syntactically. Since the structure involving involves a predicate in each conjunct, Type B coordinations interpretively differ from Type A coordinations. Specifically, the structure in (46b) shows that in Type B Coordinations, two separate events of ‘John’s going home’ and ‘Mary’s going home’ are involved, each of which is marked with a separate predicate. Finally, as the subject of each conjunct has its own predicate, covert or overt, collective predicates cannot occur in Type B coordinations.

Let us now consider examples involving object positions in the two types of coordination. As we see in (47), this is the same as (46) except that the case marker involved here is an accusative marker, as opposed to a nominative case.

(47)a. Na-nun John-kwa Mary-lul manna-ss-ta (Type A)

I-Top J-conj M-acc meet-pst-decl

b. Na-nun John-ul kuliko Mary-lul manna-ss-ta (Type B)

I-Top J-acc conj M-acc meet-pst-decl

‘I met John and Mary.’

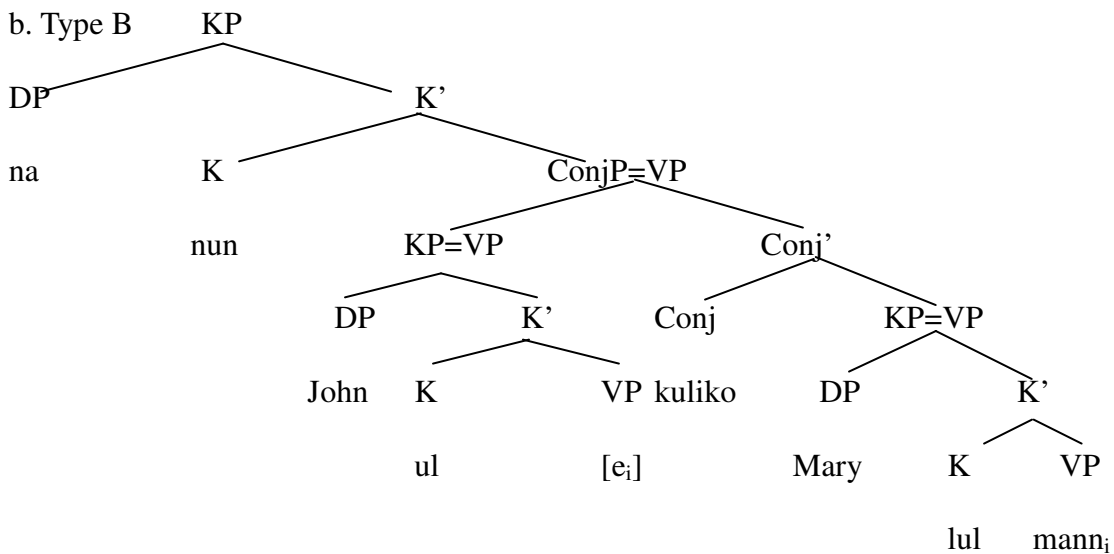
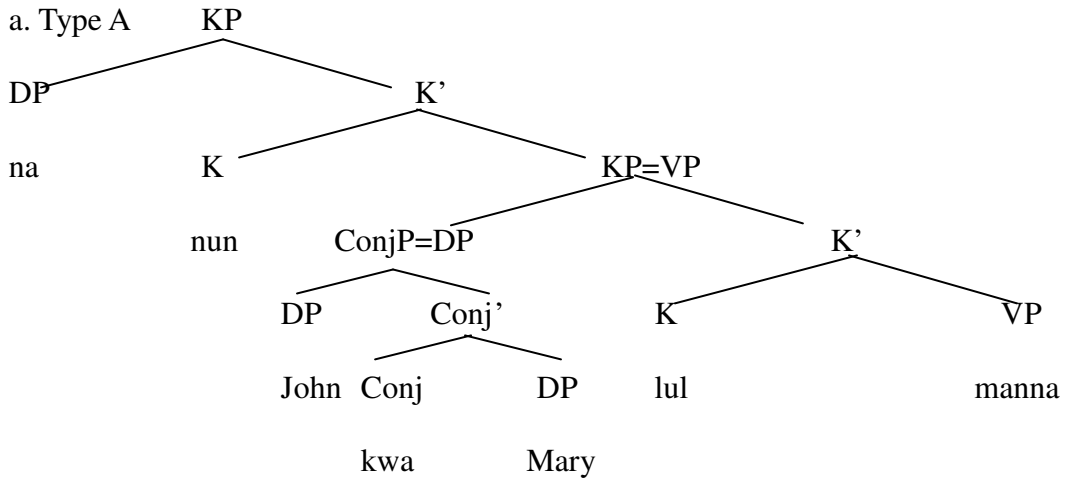

Again, Type B coordinations are not NP Coordinations and accordingly do not have NP distribution syntactically. The structure involving a predicate in each conjunct makes Type B coordinations differ interpretively from Type A coordinations. Specifically, the structure for Type

B Coordinations shows that the events of ‘meeting John’ and ‘meeting Mary’ took place separately. Finally, as the object of each conjunct has a predicate, either being covert or overt, collective predicates cannot occur in Type B coordinations.

Type A and B contrasts shown by genitive-marked NP are not that much different from the nominative- or accusative-marked examples, except that the initial case-marked conjunct licenses a null NP, not a null VP. Again, in this case as well, Type B involves two nominal predicates, which means that there are two different pieces of art work, one created by John and the other by Mary.

(48)a. John-kwa Mary-uy cakphwum (Type A)

John-conj Mary-Gen work

‘John and Mary’s work’

b. John-uy kuliko Mary-uy cakphwum (Type B)

John-Gen conj Mary-Gen work

‘John’s and Mary’s work’

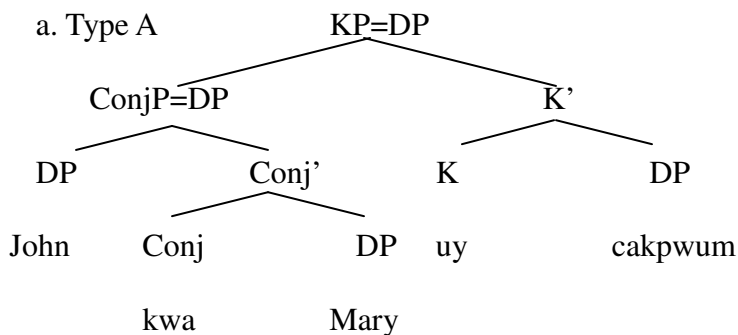

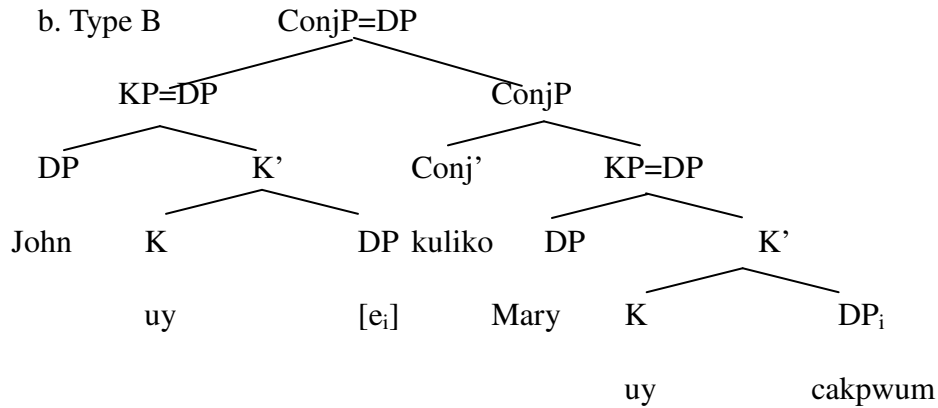

So far we have provided an alternative analysis of Type A and B Coordination Constructions and showed what makes all the syntactic and semantic differences. Some other interesting properties of examples, containing relational modifiers (selo ‘each other’, kakkak ‘respectively’) or Dummy Plural Marker (-tul), will be explained in Chapter 3, where RNR constructions are discussed, pointing to the same direction of analysis. I will further show in sub-section 4.3 how the proposed analysis derives complex sentences such as those with clausal complements or relative clauses.

4.3 Derivation of Complex Sentences

I proposed above a novel analysis called the “Incremental C-selectional Combinatoric Analysis” and showed how the system builds structures with the help of combinatory markers such as case-markers, adjectivizers and conjunctors. After discussing derivation of simple sentences in 4.1, I analyzed two main constructions of this Chapter – Type A and B Coordination Constructions in 4.2. In this subsection, I will show how complex sentences are derived under the proposed system. Complex sentences include sentences with a clausal complementation as in (49-52) and those with a relative clause as in (53).

- (49) Cheli-ka Suni-ka sakwa-lul mek-ess-ta-ko malhay-ss-ta
 C-nom S-nom apple-acc eat-pst-decl-comp say-pst-decl
 ‘Cheli said that Suni ate an apple.’
- (50) Cheli-ka sakwa-lul Suni-ka mek-ess-ta-ko malhay-ss-ta
 C-nom apple-acc S-nom eat-pst-decl-comp say-pst-decl
 ‘Cheli said that Suni ate an apple.’
- (51) sakwa-lul Cheli-ka Suni-ka ___ mek-ess-ta-ko malhay-ss-ta
 apple-acc C-nom S-nom ___ eat-pst-decl-comp say-pst-decl
 ‘Cheli said that Suni ate an apple.’
- (52) Suni-eykey Yenghi-ka Cheli-ka cenhwahay-ss-ta-ko malhay-ss-ta
 S-dat Yenghi-ka Cheli-nom call-pst-decl-comp say-pst-decl
 ‘Yenghi said to Suni that Cheli called.’
 ‘Yenghi said that Cheli called Suni.’
- (53) Cheli-ka Yenghi-ka sungcinhay-ss-ta-nun somwun-ul tul-ess-ta
 C-nom Y-nom get.promoted-pst-decl-REL rumour-acc hear-pst-decl
 ‘Cheli heard the rumour that Yenghi got promoted.’

For the derivation of these complex sentences, we introduce two additional combinatoric markers for complex clauses – complementizer *-ko* and relativizer *-(nu)n*.

Two additional combinatoric markers for complex clauses again:

Complementizer (COMP) *-ko*

COMP:

}	PHON: /ko/			
	CAT: C			
	C-SEL: <M, K ∨ V>			
	PROBE: V-CL:			
	<table border="0"> <tr> <td style="font-size: 2em; vertical-align: middle;">{</td> <td>uV5</td> </tr> <tr> <td style="font-size: 2em; vertical-align: middle;">}</td> <td>uV6</td> </tr> </table>	{	uV5	}
{	uV5			
}	uV6			

Relativizer (REL) *-(nu)n*

REL:

}	PHON: /nun/
	CAT: R
	C-SEL: <T ∨ M, D>
	PROBE: _____

4.3.1 Sentences with Clausal Complements

First, let us consider how a sentence with a clausal complement as in (54) is derived.

- (54) Cheli-ka Suni-ka sakwa-lul mek-ess-ta-ko malhay-ss-ta
 C-nom S-nom apple-acc eat-pst-decl-comp say-pst-decl
 ‘Cheli said that Suni ate an apple.’

As the K_{NOMP} ‘Cheli-ka’ cannot combine with another K_{NOMP} ‘Suni-ka’, derivation is suspended, but licenses a null predicate [e]. Derivation continues and the stranded KP ‘Suni-ka’ now

combines with the accusative KP 'sakwa-lul' and the two KP clusters search for a CLASS 2 verb and finds 'mek-ess-ta'. The whole MP now combines with the complementizer *-ko* as MP, by virtue of the feature specification of *-ko*, is taken to the left of the combinatoric marker *-ko*. The complementizer finally takes verb 'malhata' to its right and the derivation is completed, yielding sentence (54). The null predicate [e] is co-indexed with the final verb 'malhata' as they are compatible and the other verb 'mek-ta' has already been saturated, i.e., it has already discharged all its semantic argument roles.

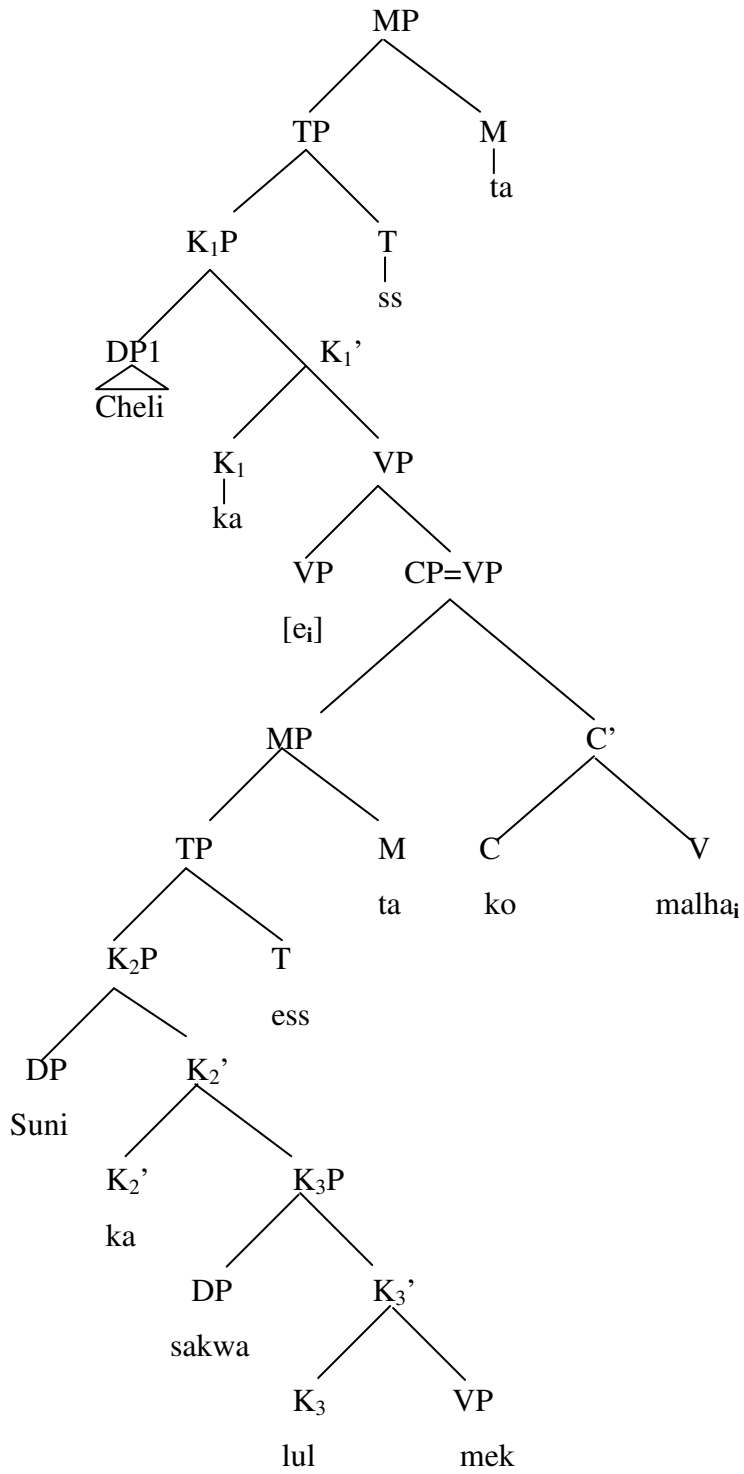

Now consider how (55) is derived.

(55)Cheli-ka sakwa-lul Suni-ka mek-ess-ta-ko malhay-ss-ta
 C-nom apple-acc S-nom eat-pst-decl-comp say-pst-decl
 Cheli said that Suni ate an apple.'

The KP 'Cheli-ka' combines with sakwa-lul, and as the KP clusters cannot combine with Suni-ka, derivation is suspended and a null predicate [e] is licensed. Now Suni-ka opens a new clause and combines with the pred 'mek-ta'. At the same time, the null predicate is also co-indexed with the Class 2 verb 'mek-ta', which the KP clusters 'Cheli-ka sakwa-lul' was looking for. This co-indexation, however, makes the derivation crash because then the two agents would be related to one predicate, as depicted in Stab 1. As it has turned out that the combination of 'Cheli-ka' with sakwa-lul' results in crash, a null pred [e] is licensed after 'Cheli-ka' to make those two KPs separate from each other. Then, 'sakwa-lul' starts a new clause and it combines with Suni-ka and the whole KPs takes 'mek-ess-ta'. The whole MP now combines with the complementizer *-ko* as MP is taken to the left of the combinatoric marker *-ko* according to the feature specification of *-ko*. The complementizer finally takes verb 'malhata' to its right and the derivation is completed, yielding sentence (55). The null predicate [e] is co-indexed with the final verb 'malhata' as they are compatible and the other verb 'mek-ta' has already discharged all its semantic argument roles/already been saturated as illustrated in Stab 2.

1st Stab: Crash as two agents are related to one predicate (s-selection of PRED)

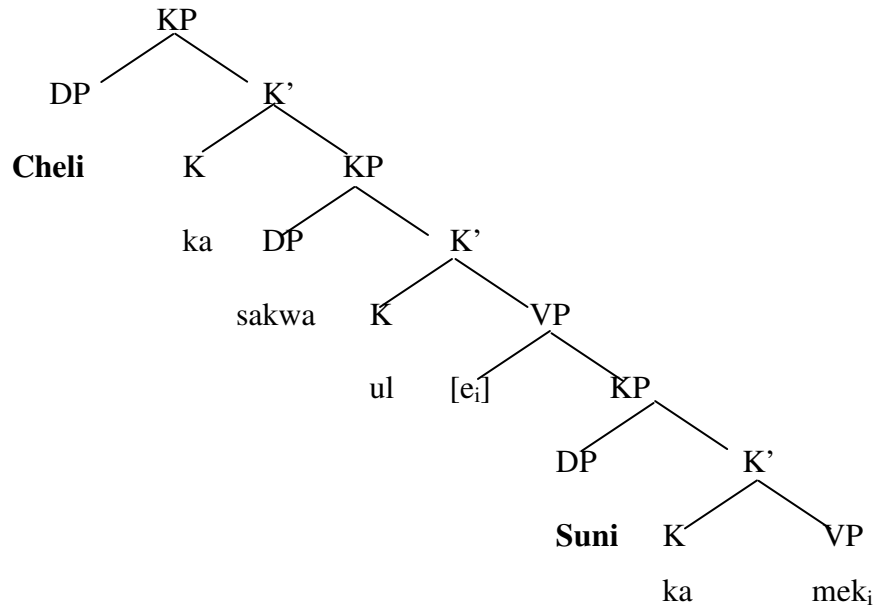

2nd Stab

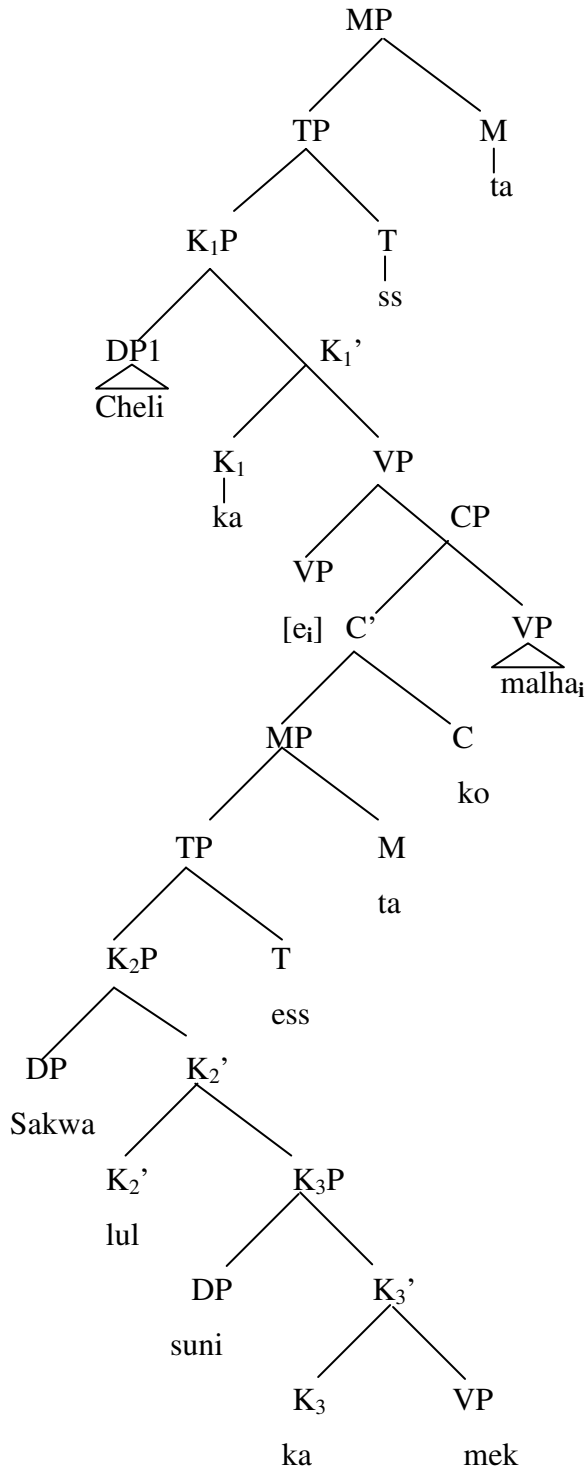

Now consider how (56) is derived. In (56), the embedded object precedes the main clause subject.

(56) sakwa-lul Cheli-ka Suni-ka ___ mek-ess-ta-ko malhay-ss-ta
 apple-acc C-nom S-nom ___ eat-pst-decl-comp say-pst-decl
 ‘Cheli said that Suni ate an apple.’

The KP ‘sakwa-lul’ combines with ‘Cheli-ka’ and as the KP clusters cannot combine with ‘Suni-ka’, derivation is suspended and the null predicate [e] is licensed. Now ‘Suni-ka’ opens a new clause and combines with the pred ‘mek-ta’. At the same time, the null predicate is also co-indexed with the Class 2 verb ‘mek-ta’, which the KP clusters ‘Cheli-ka sakwa-lul’ was looking for. This co-indexation, however, makes the derivation crash because then the two agents would be related to one predicate, as depicted in Stab 1. As it has turned out that the combination of ‘Sakwa-lul’ with ‘Cheli-ka’ results in crash, a null pred [e] is licensed after ‘Sakwa-lul’ to make those two KPs separate from each other. Then, ‘Cheli-ka’ starts a new clause and as it combines with another nominative phrase ‘Suni-ka’, derivation again is suspended and null predicate [e] is licensed. Suni-ka opens a new clause and takes ‘mek-ess-ta’. At the same time, the initial null pred [e] is resolved to ‘mek-ta’ as the accusative phrase ‘Sakwa-lul’ is compatible with Class 2 verb. The whole MP now combines with the complementizer *-ko* as MP is taken to the left of the combinatoric marker *-ko* according to the feature specification of *-ko*. The complementizer finally takes verb ‘malhata’ to its right and the derivation is completed, yielding sentence (48). The second null predicate [e] is co-indexed with the final verb ‘malhata’ as they are compatible and the other verb ‘mek-ta’ has already discharged all its semantic argument roles/already been saturated as illustrated in Stab 2.

1st Stab: Crash as two agents are related to one pred (PRED at least s-select)

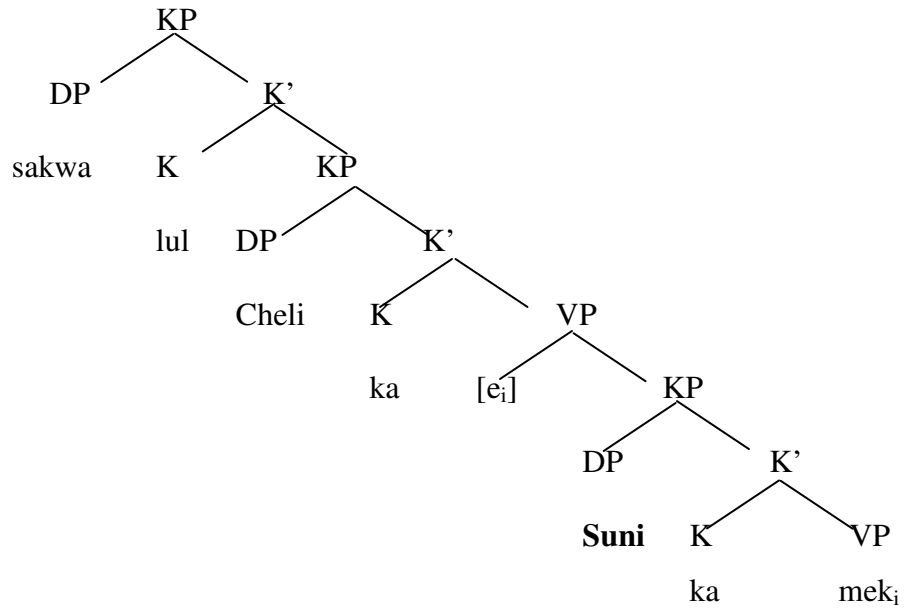

2nd Stab:

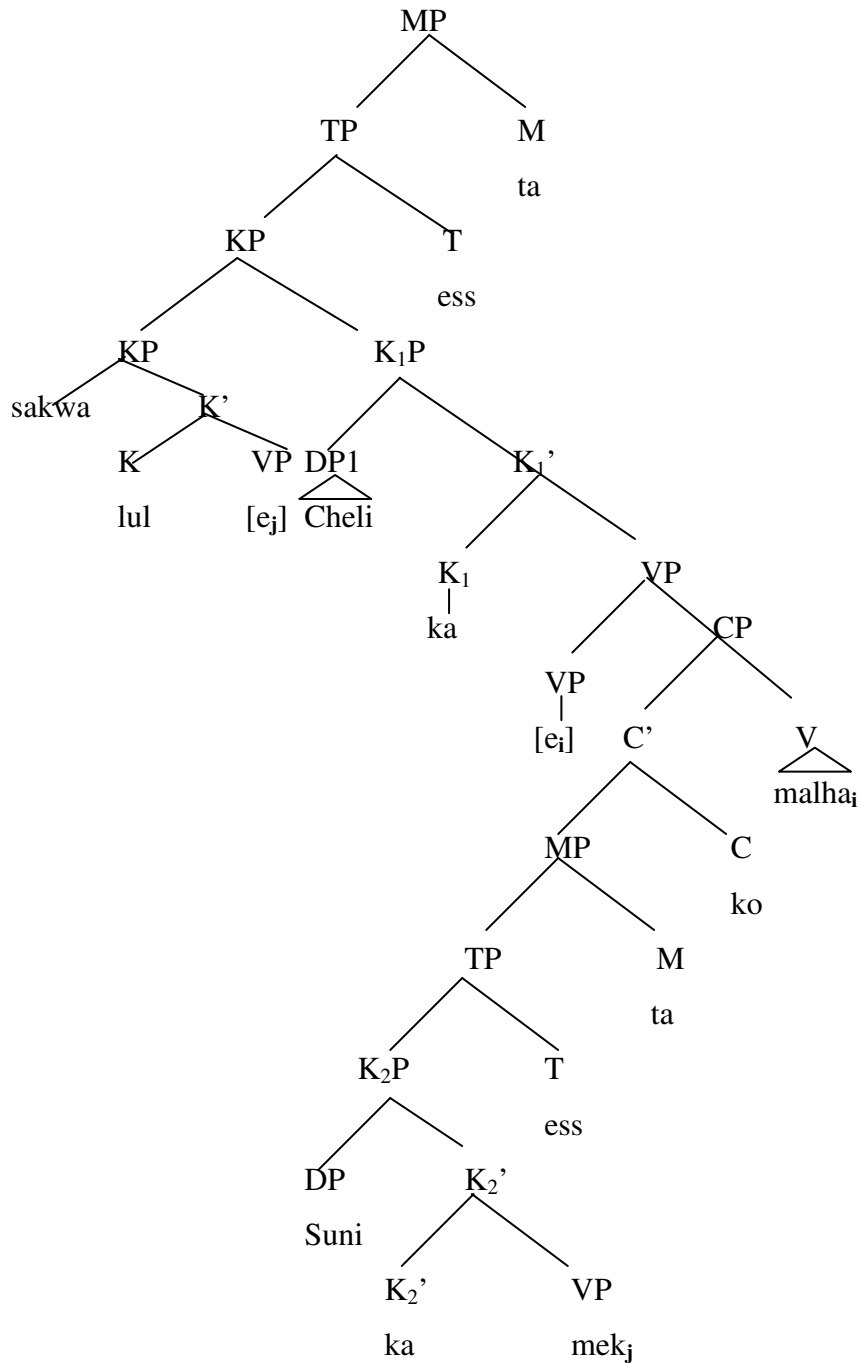

Now consider how (57) is derived. Note, this sentence can be ambiguous because 'Suni-eykey' can be related to both *cenhwaha-ta* and *malhata*.

(57)Suni-eykey Yenghi-ka Cheli-ka cenhwahay-ss-ta-ko malhay-ss-ta
 S-dat Y-nom Cheli-nom call-pst-decl-comp say-pst-decl

‘Yenghi said to Suni that Cheli called.’

‘Yenghi said that Cheli called Suni.’

The KP ‘suni-eykey’ combines with ‘Yenghi-ka’ and as the KP clusters cannot combine with ‘Cheli-ka’, derivation is suspended and the null predicate [e] is licensed. Now, ‘Cheli-ka’ opens a new clause and combines with the pred ‘cenhwaha-ta’. At this point, the KP clusters also are co-indexed with ‘cenhwaha-ta’ since they are compatible. This co-indexation, however, makes the derivation crash because then the two agents would be related to one predicate.

Now we have two options to save the derivation. The KP clusters ‘Suni-eykey yenghika’ are coindexed with malhata instead of ‘cenhwahata’ as they are compatible too. Then, we get the first interpretation ‘Yenghi said to Suni that Cheli called.’

The other option is to make the two KPs into two separate clauses. That is, ‘Suni-eykey’ licenses a null predicate. Then ‘Yenghi-ka’ opens a new clause. As it cannot combine with another nominative phrase ‘Cheli-ka’, it licenses a null predicate again. Then, ‘Cheli-ka’ combines with ‘cenhwaha-ta’ and simultaneously, the first null predicate is resolved to ‘cenhwaha-ta’ as they are compatible and the null predicates should be resolved as soon as they can. Finally, the second null predicate is co-indexed with ‘malha-ta’, yielding the interpretation ‘Yenghi said that Cheli called Suni.’

1st Reading

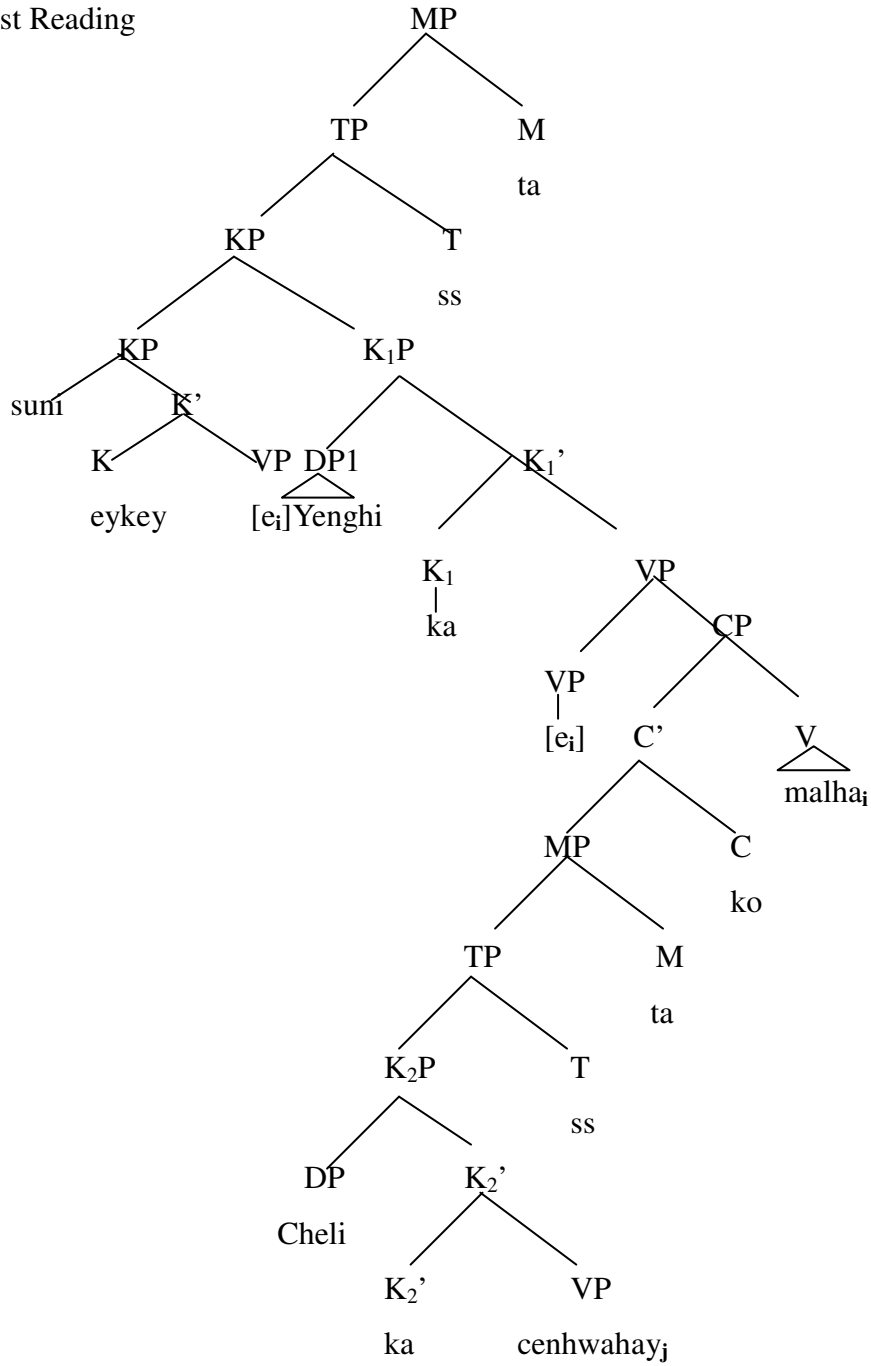

2nd Reading

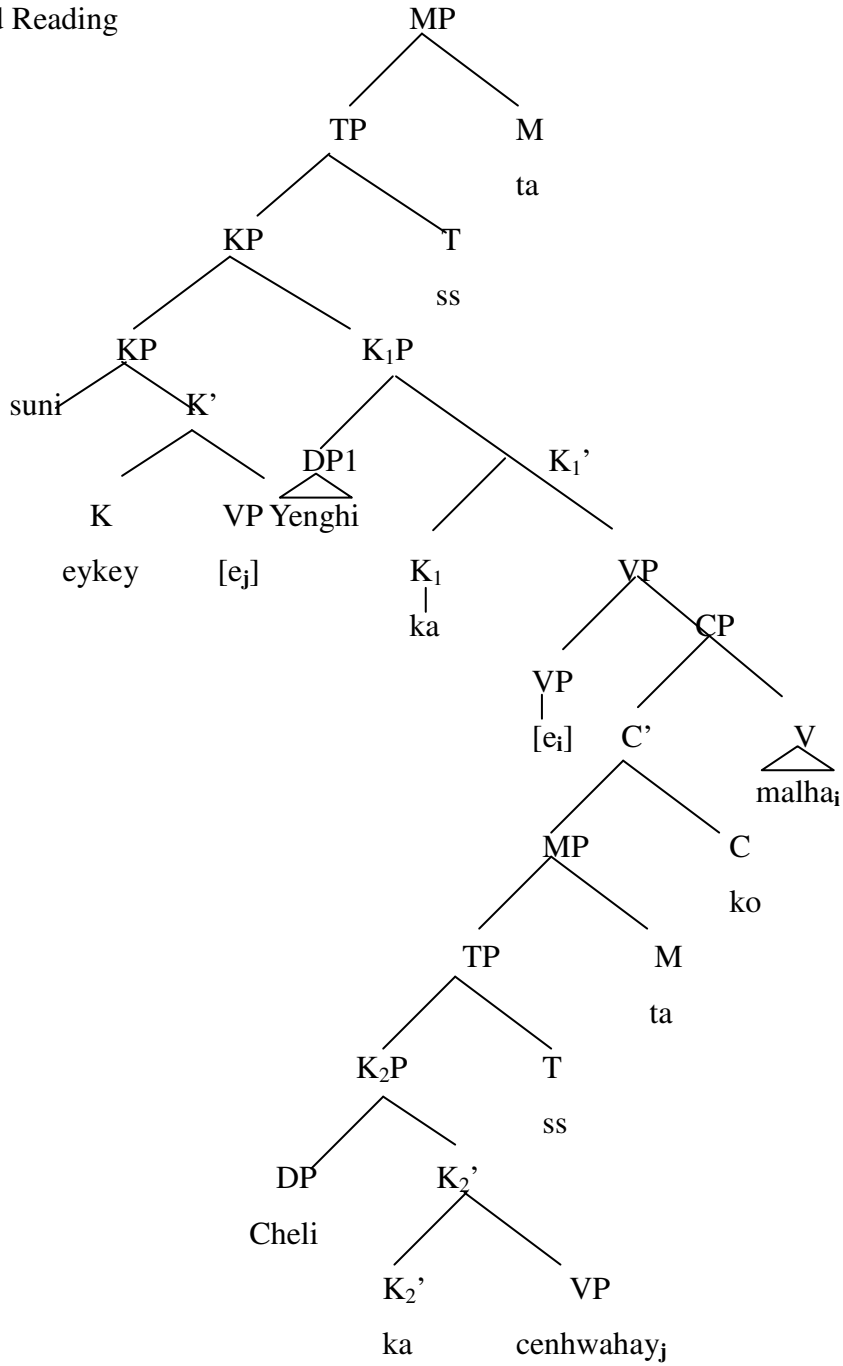

Now, let us consider sentences with relative clauses in the next subsection 4.3.2.

4.3.2 Sentences with relative clauses

(58)Cheli-ka Yenghi-ka sungcinhay-ss-ta-nun somwun-ul tul-ess-ta
C-nom Y-nom get.promoted-pst-decl-REL rumour-acc hear-pst-decl
'Cheli heard the rumour that Yenghi got promoted.'

First, let us consider how (58) is derived. The KP 'Cheli-ka' starts building a clause. As the $K_{NOM}P$ 'Cheli-ka' cannot combine with another $K_{NOM}P$ 'Yenghi-ka', derivation is suspended and it licenses a null predicate [e]. Derivation continues and the stranded KP 'Suni-ka' now combines with the predicate 'sungcinha-ta' The whole MP now combines with the relativizer *-nun* as MP is taken to the left of the combinatoric marker *-nun* according to the feature specification of it. The relativizer finally takes NP 'somwun' to its right. The whole DP combines with the accusative marker *-ul* and forms another KP. Now the KP clusters ($K_{nom} K_{acc}$) combines with the CLASS 2 verb as they are compatible. At the same time, the null predicate [e] is co-indexed with the final verb 'tul-ta' as they are compatible and the other verb 'sungcinha-ta' has already discharged all its semantic argument roles/already been saturated (since the agent role has already been assigned to Yenghi).

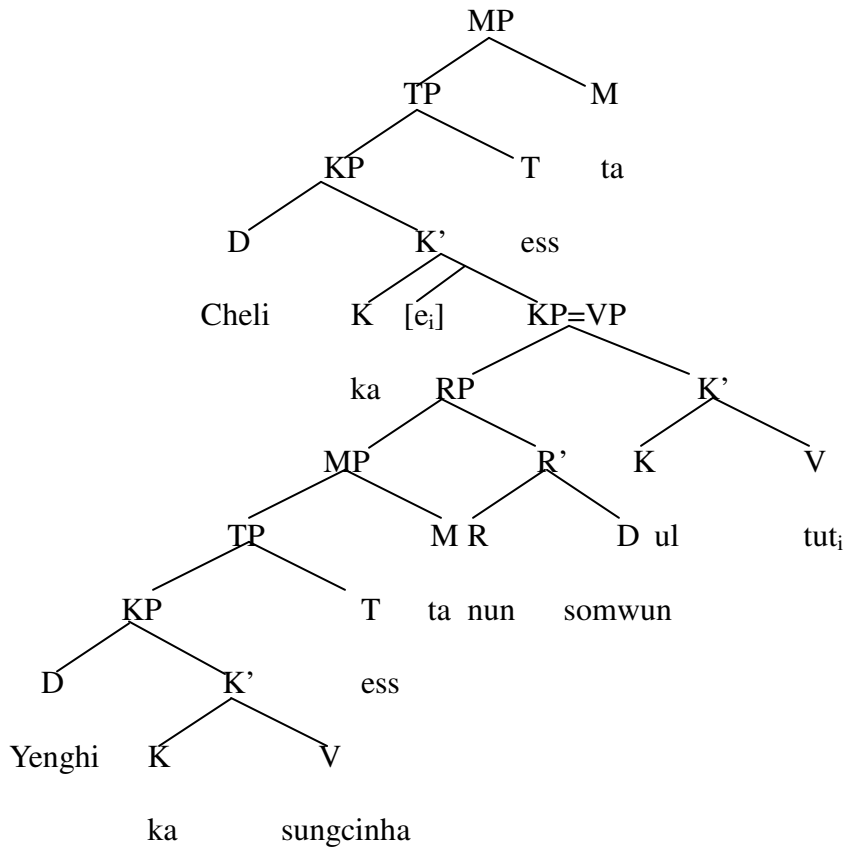

Now the derivation is complete, yielding the correct interpretation ‘Cheli heard the rumour that Yenghi got promoted.’

5. Conclusion

In this Chapter, I have discussed various properties of two types of NP coordinations, which led to the proposal of a novel analysis “Incremental C-selectional Combinatoric Analysis”. The main assumptions are that [1] Dependent markers, as combinatoric markers, play an important role in structure building in dependent marking languages such as Korean and Japanese. [2] Structures are built in a strict left-to-right fashion. [3] Elements with combinatoric markers, according to feature specifications of each marker, combine with each other and select a compatible predicate,

based on verb classifications (feature specifications of verbs). [4] Elements (NPs or CPs or ...) with dependent markers license a null predicate when derivation is suspended due to the fact that they cannot directly combine with the right next element. [5] A null predicate should be licensed as sparingly as possible and is to be resolved as soon as possible throughout the derivation (for economy of processing and the communicative efficacy) [6] The content of an empty predicate [e] is to be resolved later when a compatible, overt one is encountered. [7] When derivation fails, other ways are sought to make it successful such as opening a new clause.

Based on the above assumptions, I showed how the system works with derivation of various constructions (canonical order, local and long-distance scrambling, sentences with embedded clauses) as well as the resolution of null predicates. I also provided an analysis explaining the contrastive properties of Type A and B Coordination Constructions. The analysis, of course, will be elaborated and extended to other constructions, and the resolution of null predicates, whether verbal or nominal, will be given more detailed discussion in the following Chapters.

In terms of macroparameters, this analysis is based on the intuition that Korean /Japanese-type languages are dependent marking languages (Bouchard 2001), where dependent markers such as case-markers select compatible predicates rather than vice versa (Y-J Choi 2007). This view is supported, among others, by the discovery in Yoon and Lee (2005), who proposed that an NP coordination in which each conjunct is case-marked behaves like a clausal coordination. Since a case-marked NP always selects a predicate—null or otherwise, it follows that the coordination in question will have to be clausal. A constituent NP coordination has only one instance of case, on the second, or the final conjunct.

Chapter 3:

Right Node Raising Constructions in Korean

This chapter is concerned with Right Node Raising Constructions (RNR, hereafter) in Korean. RNR constructions are two sentences that have a shared string of words realized once in the rightmost position on the surface. In transformational approaches to RNR, the shared rightmost strings in RNR were believed to have been raised across-the-board from the conjoined sentences. The term “Right Node Raising” reflects this analysis. Despite the fact that problems with movement analysis have been known for some time, the constructions are still referred to as RNR. I will therefore continue using that term to designate the construction in questions. Sentences (1-2) exemplify English and Korean RNR constructions respectively.

(1) a. Mary likes, but Bill hates – baseball.

= Mary likes baseball, but Bill hates baseball.

b. Mary can, but Bill can't – swim across the river.

= Mary can swim across the river, but Bill can't swim across the river.

c. Mary gave to John, and Bill gave to Sue – an expensive present.

= Mary gave to John an expensive present, and Bill gave to Sue an expensive present.

(2) a. Cheli-nun sakwa-lul kuliko Yenghi-nun banana-lul acwu coaha-nta

Cheli-Top apples-acc conj Yenghi-Top banana-acc a.lot like-decl

= Cheli-nun sakwa-lul acwu coaha-nta kuliko

Yenghi-nun banana-lul acwu coaha-nta¹⁶

‘Cheli likes apples a lot and Yenghi likes bananas a lot’

b. Cheli-nun Yong-eykey kuliko Tony-nun Sue-eykey CD-lul

C-Top Y-Dat conj T-Top Soon-Dat CD-acc

cwu-ess-ta

give-pst-decl

= Cheli-nun Yong-eykey CD-lul cwu-ess-ta kuliko

Tony-un Sue-eykey CD-lul cwu-ess-ta

‘Cheli gave Yong CD and Tony gave Sue CD’

Before examining these constructions, we also present CoRNR¹⁷ constructions briefly here to clarify that we take these two constructions as related, but independent constructions. CoRNR constructions are similar to RNR constructions, but they are different in the sense that the pivots (the conjoined predicates) in CoRNR are interpreted distributively with respect to each conjunct as we see in (3-4).

(3) Cheli-ka Banana-lul kuliko Yenghi-ka sakwa-lul (kakkak)

Cheli-nom Banana-acc conj Yenghi-nom apple-acc (respectively)

coaha-ko silheha-n-ta

like-conj dislike-pres-decl

¹⁶ For ease of exposition, when RNR is paraphrased as two full sentences, I will call the first conjunct the antecedent and the second one the target.

¹⁷ This is an abbreviation for Coordination under RNR, which was originally named by de Vos and Vicent (2005). We take this term to refer to constructions involving a conjoined predicate in the shared (pivot) part of RNR constructions.

= Cheli-ka Banana-lul coaha-n-ta kuliko
 Cheli-nom Banana-acc like-pres-decl conj
 Yenghi-ka sakwa-lul silheha-n-ta
 Yenghi-nom apple-acc dislike-pres-decl
 ‘Cheli likes bananas and Yenghi dislikes apples’

(4) John loves and Peter hates Mary and Susan (respectively).

= John loves Mary and Peter hates Susan

As CoRNR constructions will be discussed in detail in section 5 of this chapter, we put them aside at this point and return to RNR constructions now.

Right Node Raising constructions in Korean have long been a topic of debate, but a fully satisfactory analysis that accounts for all the empirical phenomena found in the constructions has yet to be proposed. This chapter thus identifies the exact empirical phenomena found in those constructions, reviews previous proposals, pointing out problems they have and then provides an alternative analysis for the constructions. Section 1 introduces some interesting empirical phenomena observed in Korean RNR constructions. Section 2 reviews representative previous proposals and points out problems each proposal has. Section 3 proposes an alternative analysis (ICCA), where the initial conjunct contains a null predicate whose contents are unified with the overt predicate in the final conjunct. More importantly, problematic data containing the Relational Modifiers (RM) *-kakkak*, *-selo* or Dummy Plural Marker (DPM) *-tul* are explained under the analysis, in which case both conjuncts license a null predicate and the RM/DPM are positioned outside of the coordination complex. I also show that the analysis potentially accounts for other novel data of RNR constructions involving multiple nominative or accusative

constructions. Section 4 shows advantages of the alternative analysis; the system explains various phenomena regarding strict/sloppy interpretations, morphological mismatches, (dis)ambiguity of constructions. Section 5 extends the analysis to a type of RNR construction that is called Co-RNR construction. Section 6 concludes this chapter.

1. Properties of RNR Constructions

This section presents a survey of the morpho-syntactic and semantic properties that RNR constructions exhibit. Among various properties I will focus on presenting those that have called for an explanation but received no desirable accounts under many analyses proposed so far. Section 1.1 introduces data to show that morphological mismatches are allowed between the antecedent and the target sentence in Korean. Specifically, the shared parts need not be identical morphologically. In some cases, the target (the deletion part) does not have exactly the same form as the antecedent. Section 1.2 presents examples with pronouns that show sloppy and strict readings. Section 1.3 presents data with relational modifiers such as *kakkak* ‘respectively’ and dummy plural markers such as *tul*. These are the crucial data that challenge both the movement and the phonetic deletion analysis of RNR constructions. Section 1.4 shows some scope phenomenon -- scope interaction resulting in ambiguity (or the lack thereof) of sentences depending on the scope of quantifiers, negation and prosody such as pause. While going through various data, we will examine in detail the morphosyntactic and semantic properties of RNR constructions in Korean and the need for a new analysis that accommodates all the phenomena observed.

1.1 Morphological Mismatches in RNR

While it seems that the Pivot in RNR must be well-formed when it is ‘put back’ into the component sentences, there are some cases where replacing the Pivot into the unreduced ‘sources’ of RNR result in ill-formedness. As observed by Boskovic (1995, 2005), some RNR constructions in English allow morphological mismatches between the antecedent and the target as in (5). In (5), the mismatched form must be matched to the final conjunct, and not the initial conjunct. That is, there is an adjacency effect.

- (5) a. ?John will ~~sleep in his house~~, but Mary probably was – **sleeping in his office**.
b. John will ~~sleep in his office~~, and Peter already has – **slept in his office**.
c. John hasn’t ~~questioned our motives~~, but Bill may be – **questioning our motives**.
d. John has ~~slept in his office~~, but Peter definitely will – **sleep in his office**.

Korean also exhibits similar properties; (6a) is a RNR construction, resulting from (6b) under a reduction/ellipsis analysis (Example from D-H Chung 2004). In (6b), the antecedent and the target are not the same as the target involves a copula ‘i’. The target, however, still undergoes RNR despite the morphological mismatch.

(7b) also exhibits a mismatch. While the antecedent sentence contains an honorific agreement morpheme ‘si’, the target sentence does not. Even though the antecedent and the target are different in terms of morphology, the target still goes through RNR, resulting in (7a).

- (6) a. John-i sensayngnim kuliko Mary-ka uysa-**ta**
 John-nom teacher conj Mary-nom doctor-decl

‘John is a teacher and Mary is a doctor.’

- b. John-i sensayngnim-i-ta (vs. *sensayngnim-Ø-ta)

John-nom teacher-cop-decl

‘John is a teacher.’

Mary-ka uysa-**ta**

May-nom doctor-decl

‘Mary is a doctor.’

- (7) a. John-i chayk-ul kuliko halapeci-kkeyse sinmwun-ul
John-nom book-acc conj Grand.father-hon.nom newspaper-acc
ilk-usi-n-ta
read-hon-pres-decl

‘John reads a book and his grandfather reads a newspaper.’

- b. ku ay-ka chayk-ul ilk-nun-ta (vs. #ilk-usi-n-ta)
the child-nom book-acc read-pres-decl

‘John reads a book.’

Halapeci-kkeyse sinmwun-ul ilk-usi-n-ta

Grand.father-hon.nom newspaper-acc read-hon-pres-decl

‘His grandfather reads a newspaper.’

So far we have seen that the antecedent and target of RNR constructions can show morphological and morphosyntactic mismatches. The following sections introduce other properties of RNR constructions in Korean.

1.2 Strict and Sloppy Readings

As pointed out by S-W Ha (2006), when pronouns are involved in the pivot of RNR constructions, both strict and sloppy interpretations are possible in the first conjunct, while the second conjunct pronoun has only one reading where the pronoun is bound by Tom. This is exemplified in (8).

(8) **John-un** 9-si-ey kuliko **Tom-un** 10-si-ey
John-top 9-time-at and Tom-top 10-time-at
ku-uy cip-ulo ka-ss-ta
His home-to go-past-decl

a. John went to his(=Tom's) house at 9:00 and Tom went to his(=Tom's) house at 10:00.

(Strict reading in the first conjunct)

b. John went to his(=John's) house at 9:00 and Tom went to his(=Tom's) house at 10:00.

(Sloppy reading in the first conjunct)

1.3 Relational Modifiers and Dummy Plural Markers Acceptable in RNR

RNR constructions allow RMs such as *kakkak* 'respectively' and DPMs such as *tul* in Korean, which are called 'Plural Dependent Elements/Expressions' (PDE) (D-H Chung 2004). PDEs have been a problem for RNR analyses proposed so far because neither the movement nor the deletion analysis can satisfactorily account for the RNR constructions containing PDEs. Specifically, PDEs are successfully licensed only when they are in RNR pivot and not in the conjuncts themselves. Before going through RNR constructions, we first review the environment where the plural dependent elements are licensed in simple sentences in Korean.

1.3.1. DPM *-tul*

As noted by Choe (1988) (see also Chung 2004), dummy plural marker *-tul* is licensed when it is c-commanded by a local plural subject. Specifically, (9a-c) show that *-tul* should be linked to a plural element (plurality condition) as in (9a-b). The sentence is not acceptable if it is linked to a singular subject as we see in (9c).

- (9) a. kutul-i piano-lul cal-tul chi-ess-ta
 they-nom piano-acc well-DPM play-pst-decl
 ‘They played the piano well.’
- b. Cheli-wa Yenghi-ka piano-lul cal-tul chi-ess-ta
 Cheli-conj Yenghi-nom piano-acc well-DPM play-pst-decl
 ‘Cheli and Yenghi played the piano well.’
- c. *Cheli-ka piano-lul cal-tul chi-ess-ta
 Cheli-conj piano-acc well-DPM play-pst-decl
 ‘Cheli played the piano well.’

DPM *-tul* cannot be licensed unless its antecedent functions as subject. *Tul* is successfully licensed in (10a) as the plural antecedent is in the subject position, whereas (10b) is unacceptable as the plural antecedent is an object, not a subject.

- (10)a. Cheli-wa Yenghi-ka violin-ul cal-tul yencwuhay-ss-ta
 Cheli-conj Yenghi-nom violin-acc well-DPM play-pst-decl
 ‘Cheli and Yenghi played the violin well.’

b. *Cheli-ka violin-kwa flute-lul cal-tul yencwuhay-ss-ta

Cheli-nom violin-conj flute-acc well-DPM play-pst-decl

‘Cheli played the flute and the violin well.’

DPM *-tul* is c-commanded by its antecedent as in (11) and should be c-commanded in the base position as illustrated by (12). (11a) is acceptable as *-tul* is c-commanded by the plural antecedent ‘Cheli-wa Yenghi’, whereas (11b) is out as *-tul* cannot be c-commanded by its plural antecedent. (12) further shows that the c-command relation should hold in the base position. (12a) is the same as (11a) except that ‘ilccik-tul’ is scrambled to the sentence-initial position. As the c-command relation holds in the base-position, not in the surface, (12a) is acceptable. By contrast, (12b) is a scrambled form of (11b). As the underlying form (11b) is out, (12b) is ruled out as well.

(11) a. ama Cheli-wa Yenghi-ka ilccik-**tul** chwulpalhay-ss-ul kes-i-ta

Probably Cheli-conj Yenghi-nom early-DPM depart-pst-conject-cop-decl

‘Probably Cheli and Yenghi departed early.’

b. * ama-**tul** Cheli-wa Yenghi-ka ilccik

Probably-DPM Cheli-conj Yenghi-nom early

chwulpalhay-ss-ul kes-i-ta

depart-pst-conject-cop-decl

(12)a. ilccik-**tul** ama Cheli-wa Yenghi-ka chwulpalhay-ss-ul kes-i-ta

early-DPM Probably Cheli-conj Yenghi-nom depart-pst-conject-cop-decl

‘Probably Cheli and Yenghi departed early.’

- b.* Cheli-wa Yenghi-ka ama-**tul** ilccik chwulpalhay-ss-ul kes-i-ta
 Cheli-conj Y-nom Probably-DPM early depart-pst-conject-cop-decl

1.3.2 Licensing of Relational Modifiers – *selo* ‘each other’ and *kakkak* ‘respectively’

As also pointed out by Chung (2004), Relational modifiers *selo* and *kakkak* are licensed when they are bound by plural antecedent; (13c-14c) are ruled out as the RM are bound by ‘singular’ antecedent, not by ‘plural’ antecedent.

- (13) a. wuli-nun **selo**-eykey kong-ul tenci-ss-ta
 we-Top each.other-dat ball-acc throw-pst-decl

‘We threw a ball at each other.’

- b. Cheli-wa Yenghi-nun **selo**-eykey kong-ul tenci-ess-ta
 Cheli-conj Yenghi-Top each.other-dat ball-acc throw-pst-decl

‘Cheli and Yenghi threw a ball at each other.’

- c. *Cheli-ka **selo**-eykey kong-ul tenci-ess-ta
 Cheli-nom each.other-dat ball-acc throw-pst-decl

‘Cheli threw the ball at each other.’

- (14) a. wuli-nun **kakkak** piano-lul yencwuhay-ss-ta
 we-Top respectively piano-acc play-pst-decl

‘We played the piano respectively.’

- b. Cheli-wa Yenghi-nun **kakkak** piano-lul yencwuhay-ss-ta
 Cheli-conj Yenghi-Top respectively piano-acc play-pst-decl

‘Cheli and Yenghi played the piano respectively.’

c. *Cheli-nun **kakkak** piano-lul yencwuhay-ss-ta

Cheli-Top respectively piano-acc play-pst-decl

‘Cheli played the piano respectively.’

(15a-c) further show that ‘selo’ needs be bound by a plural antecedent either at underlying representation (UR) where the element ‘selo’ does not undergo scrambling or on the surface. (15a) is acceptable as ‘selo’ is bound by a plural subject antecedent ‘Cheli-wa Yenghi’. As (15b) is a scrambled form of (15a), it is also acceptable since ‘selo’ is still bound by a plural subject before scrambling. (15c) is ruled out as this sentence is in canonical order and ‘selo’ does not have a plural antecedent neither at S-structure nor at UR.

(15)a. Cheli-wa Yenghi-nun selo-eykey kong-ul tenci-ess-ta

Cheli-conj Yenghi-Top each.other-dat ball-acc throw-pst-decl

‘Cheli and Yenghi threw a ball at each other.’

b. selo-eykey Cheli-wa Yenghi-nun kong-ul tenci-ess-ta

each.other-dat Cheli-conj Yenghi-Top ball-acc throw-pst-decl

‘Cheli and Yenghi threw a ball at each other.’

c. * selo-ka Cheli-wa Yenghi-eykey kong-ul tenci-ess-ta

each.other-nom Cheli-conj Yenghi-dat ball-acc throw-pst-decl

The antecedent of ‘selo’, however, does not need serve as a subject of the sentence as that of DPM ‘tul’ does. (16) confirms this as ‘selo’ in this case has a plural object ‘Yenghi and Tong’ as its object.

(16) Cheli-ka Yenghi-wa Tong-ul selo-eykey sokayhay-ss-ta
 Cheli-nom Yenghi-conj Ton-acc each.other-dat introduce-pst-decl
 ‘Cheli introduced Yenghi and Tong to each other.’

In a similar fashion, *kakkak* does not necessarily have to have a plural antecedent in a subject position. (17a-c) further shows that ‘kakkak’ needs to have a plural NP in its local domain and it can be dislocated to any positions as in (17a’-a’’) in a sentence once licensed; specifically, the antecedent does not have to be in the subject position of the sentence as in (17b-c).

(17)a. John-kwa Mary-nun **kakkak** piano-lul yencwuhay-ss-ta
 John-conj Mary-Top respectively piano-acc play-pst-decl
 ‘John and Mary played the piano respectively.’

a’. John-kwa Mary-nun piano-lul **kakkak** yencwuhay-ss-ta

a’’. John-kwa Mary-nun piano-lul yencwuhay-ss-ta **kakkak**

b. Mary-ka **kakkak** piano-wa violin-ul yencwuhay-ss-ta
 Mary-nom respectively piano-conj violin-acc play-pst-decl
 ‘Mary played the piano and violin respectively.’

c. Mary-ka piano-wa violin-ul **kakkak** yencwuhay-ss-ta
 Mary-nom piano-conj violin-acc respectively play-pst-decl
 ‘Mary played the piano and violin respectively.’

So far we have seen the licensing condition of plural dependent elements such as dummy plural marker and relational modifiers. Close observation shows that dummy plural marker *-tul* needs

to have a plural subject as its antecedent. Relational modifiers, however, does not necessarily have a plural antecedent in the subject position and, instead, it can have a plural NP antecedent in the object position of a sentence.

1.3.3 RNR Constructions with PDE

In previous sub-sections, we have described the conditions that need to be met for plural dependent elements (PDEs) to be licensed. PDEs have been a problem for RNR analyses proposed so far because neither the movement nor the deletion analysis can account for the fact that PDEs are successfully licensed only when they are in RNR pivot and not in the conjuncts themselves. This section presents some RNR constructions involving plural dependent elements and discusses what they imply with regard to the structure of RNR constructions.

First, as we see in (18), RNR constructions allow dummy plural marker *-tul*, which, in a simple sentence, is licensed by plural subject antecedent.

- (18) Cheli-ka piano-lul kuliko Yenghi-ka violin-ul
 Cheli-nom piano-acc conj Yenghi-nom violin-acc
 cal-tul yencwuhay-ss-ta
 well-DPM play-pst-decl
 ‘Cheli played the piano well and Yenghi played the violin well.’

Secondly, RNR constructions allow relational modifiers *selo* and *kakkak*, which are licensed when having plural NP antecedents in its local domain.

(19)Cheli-ka cangmi-lul kuliko Yenghi-ka CD-lul

Cheli-ka rose-acc conj Yenghi-nom CD-acc

selo-eykey senmwul-lo cwu-ess-ta

each.other-dat present-as give-pst-decl

‘Cheli gave roses to Yenghi and she gave CD to him as a present.’

(20)Cheli-ka mwunhak-ul kuliko Yenghi-ka enehak-ul

Cheli-nom literature-acc conj Yenghi-nom linguistics-acc

kakkak yelsimhi kongpwuhay-ss-ta

respectively hard study-pst-decl

‘Cheli and Yenghi studied literature and linguistics respectively hard.’

Observation so far shows that RNR constructions, two conjuncts with each having a singular NP subject behave like sentences with plural NP subjects in terms of allowing plural NP modifiers such as *tul*, *kakkak* and *selo*.

1.4 Disappearance of Ambiguity in RNR constructions

As pointed out by previous researchers (K-W Sohn (2001), D-H An (2007)), the full sentence paraphrase (with coordination) of certain RNR have ambiguous readings that are missing in the RNR versions. Specifically, (21) is ambiguous depending on which scopes over which between the negation and the quantifier. When the quantifier ‘manhun’ scopes over the negation ‘mos’, (which is possible/marked by putting a pause after the phrase ‘manhun chinkwu-lul’), the sentence has the reading ‘there are many of John’s friends whom John did not invite to his house.’ However, when the negation ‘mos’ scopes over the quantifier ‘manhun’, it is interpreted

as ‘It is not the case that John invited many friends to his house. He invited a few of his friends.’

(21)olhay-nun John-i manhun chinkwu-lul
this.year-Top John-nom many friend-acc
cip-ey chotayha-ci mos hay-ss-ta
house-to invite Neg do-pst-decl

[ambiguous in a simple sentence]

‘There are many of John’s friends whom John did not invite to his house this year.’

‘It is not the case that John invited many friends to his house. He invited a few of his friends this year.’

When this sentence is located in an RNR construction without the quantifier and the negation separated by *kuliko* as in (22), the sentence is still ambiguous.

(22)olhay-nun John-i kuliko caknyen-ey-nun Mary-ka
this.year-Top John-nom conj last.year-Top M-nom
manhun chinkwu-lul cip-ey chotayha-ci mos hay-ss-ta
many friend-acc house-to invite- Neg do-Pst-decl

[ambiguous in RNR]

However, as we see in the initial conjunct of (23) where the quantifier and the negation are divided by *kuliko*, the sentence has only one meaning where the quantifier scopes over the negation - ‘For many of John’s friends, he did not invite them to his house and for all of Mary’s

friends, she invited none of them.’

(23) John-i manhun chinkwu-lul kuliko Mary-ka motun chinkwu-lul
John-nom many friend-acc conj Mary-nom all friend-acc
cip-ey chotayha-ci mos hay-ss-ta
house-to invite Neg do-pst-decl

‘For many of John’s friends, he did not invite them to his house and for all of Mary’s friends, she invited none of them.’

Similarly, the following sentence (D-H An 2007) is ambiguous between two readings depending on how it is read prosodically.

(24) Mary-nun **wus-umyense** cilmwunha-nun haksayng-ul ttayli-ess-ta
M-Topic with.a.smile asking.questions student-acc hit-pst-decl
[ambiguous in a simple sentence]

a. Mary-nun // wus-umyense cilmwunha-nun haksayng-ul ttayli-ess-ta
‘Mary hit a student who is asking a question while smiling’

b. Mary-nun wus-umyense // cilmwunha-nun haksayng-ul ttayli-ess-ta
‘While smiling, Mary hit a student who was asking a question’

This sentence becomes unambiguous when located in an RNR context as in (25). As the pause would be after the adverb ‘wus-u-myense’, the sentence can no longer have the interpretation where it modifies ‘cilmwunha-nun’ – the first meaning (24a).

(25) Mary-nun **wus-u-myense** kuliko Jane-un **insangssumyense**
 Mary-T with.a.smile conj Jane-T with.a.frown
 cilmwunha-nun haksayng-ul ttayli-ess-ta
 asking.questions student-acc hit-pst-decl
 [unambiguous]

So far we have seen various interesting empirical phenomena in RNR constructions. Before attempting to provide an analysis to account for all the data in a unified fashion, we discuss previous proposals on RNR constructions, which do not satisfactorily account for all the crucial facts: [1] Morphological Mismatches are allowed. [2] Both strict and sloppy reading is possible. [3] PDEs are licensed in the RNR pivot. [4] The ambiguity of a sentence disappears in an RNR context.

2. Review of Previous Proposals

This section reviews previous proposals on RNR constructions. There are three representative approaches on RNR constructions – *Movement* vs. *Multi-Dominance* vs. *Deletion Under Identity*.

2.1 Movement Analysis (Ross 1967, Postal 1974, Abbott 1976, Grosu 1976, Sabbagh 2007)

2.1.1 How it works

The movement analysis assumes that the shared constituent *moves* out of both conjuncts across-the-board and adjoins to the entire coordinated sentence. For example, (26) is analyzed as in (27).

(26)a. Mary likes, but Bill hates – baseball.

= Mary likes ~~baseball~~, but Bill hates baseball.

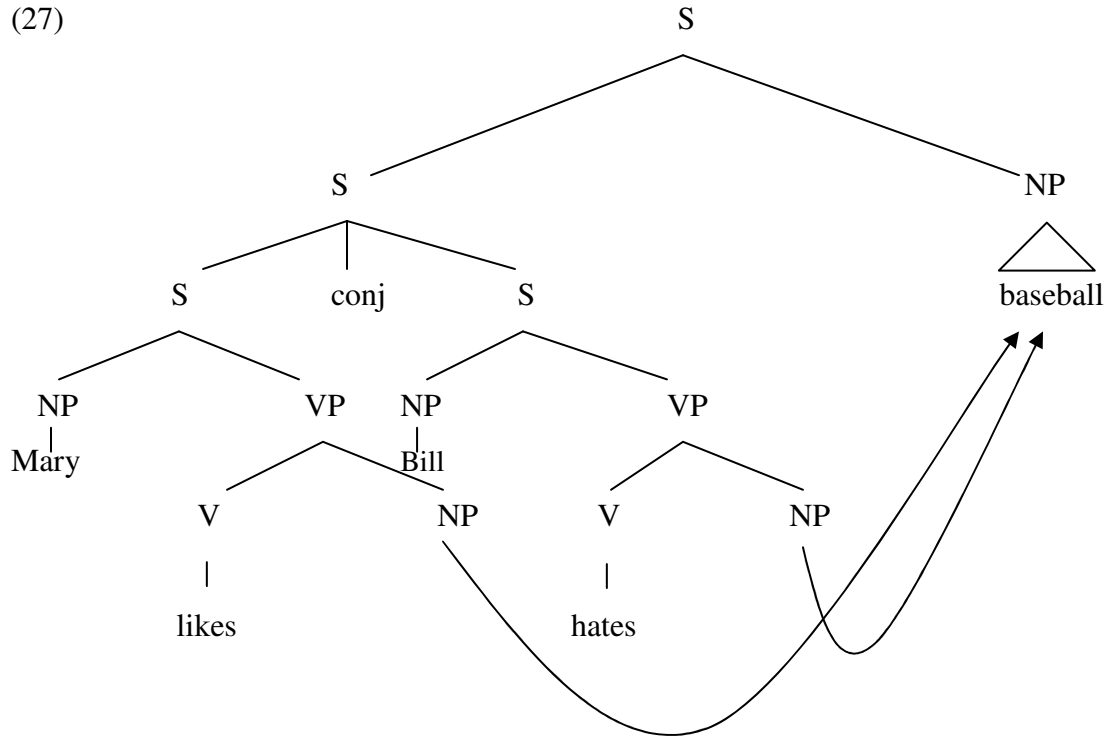

2.1.2 Problems

Though plausible, movement analysis has the following problems. First, if we consider examples (28-29), they involve movement of non-constituents.

(28) Wallace will give **t** and Wendolene will send **t** [some crackers to Gromit for his birthday]

(29) John-un Mary-uy **t** (kuliko) Tom-un Jane-uy **t**

John-Top Mary-Gen (conj) Tom-Top Jane-Gen

[chayk-ul pilli-ess-ta]

book-acc borrow-pst-decl

‘John borrowed Mary’s book and Tom borrowed Jane’s book’

Second, data (30-31) show examples with subjacency violation. Specifically, in (30-31), ‘living in Seoul’ and ‘writing’ move out of the relative clause under the movement analysis.

(30) I know [[a man who loves *e*] and [a woman who hates *e*]] [living in Seoul]

(31) John-un Tom-i t kuliko Mary-nun Jane-i t [ssu-n kul-ul
 J-Top T-nom conj Mary-Top J-nom write-rel. writing-acc
 ilk-ess-ta]
 read-pst-decl
 John read what Tom wrote and Mary read what Jane wrote’

Third, binding facts are not well accounted for under the movement analysis. Under movement analysis, the shared part is adjoined to some higher position, c-commanding other NPs in the first and the second clause. This structure predicts (32a) to be unacceptable since the pronoun ‘she’ c-commands ‘Mary’, contrary to fact. Similar account can be made as to (33a). If we consider (32b), it is predicted to be acceptable since Mary c-commands ‘she’. Similar problems arise in the Korean data given in (33b).

(32)a. Mary_i said, and I happen to agree, [that she_i needs a car] (McCawley xxxx)

b. *She_i said, and I happen to agree, [that Mary_i needs a car]

(33)a. Nay-ka Sue-eykey kuliko Cheli_i-ka Mary-eykey
 I-nom Sue-dat conj Cheli-nom Mary-dat
 [ku_i-ka cha-ka philyoha-ta-ko malhay-ss-ta]
 he-nom car-nom need-decl-comp tell-pst-decl

‘I told Sue that he (=Cheli) needed a car and Cheli_i told Mary that he_i needed a car’

b.*	Nay-ka	Sue-eykey	kuliko	ku _i -ka	Mary-eykey
	I-nom	Sue-dat	conj	he-nom	Mary-dat
	[Cheli _i -ka	cha-ka	philyoha-ta-ko		malhay-ss-ta]
	Cheli-nom	car-nom	need-decl-comp		tell-pst-decl

‘I told Sue that Cheli needed a car and he_i told Mary that Cheli_i needed a car’

Thus, movement account has been abandoned by many researchers (cf. Sabaggh 2007) and non-movement analyses have been proposed such as Multi-dominance and PF-Deletion Account. Next subsection first reviews Multi-Dominance Analysis.

2.2 Multi-Dominance Analysis (McCawley 1982, Levine 1985, McCloskey 1986, Phillips 1996, Wilder 1999, D-H Chung 2004, Bachrach and Katzir 2006)

2.2.1 How it works

There is just one occurrence of the RNR pivot, which is multiply dominated from a position within each conjunct of the coordinate structure. Specifically, example (34) is analyzed as in (35), and the problem movement analysis faces with regard to binding no longer arise mainly because the shared part stays in situ (or low) without raising to some higher position. Also, it involves no movement, so it can account for the fact that the RNR does not obey constraints on movement.

(34)	Nay-ka	Sue-eykey	kuliko	Cheli _i -ka	Mary-eykey
	I-nom	Sue-dat	conj	Cheli-nom	Mary-dat

[ku_i-ka cha-ka philyoha-ta]-ko malhay-ss-ta
 he-nom car-nom need-decl-comp tell-pst-decl

‘I told Sue that he (Cheli) needed a car and Cheli_i told Mary that he_i needed a car’

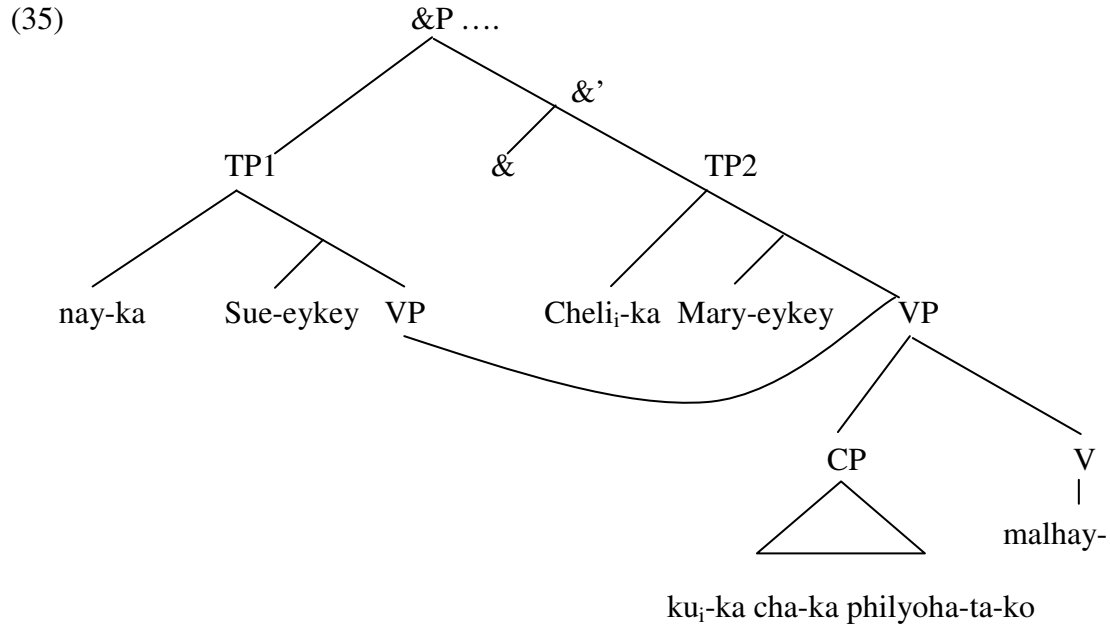

Further claimed advantages of the MD Analysis (D-H Chung 2004) are in constructions with Relational Modifiers (RM) and Dummy Plural Markers (DPM) in the RNR Pivot as illustrated in (36-38).

(36)a. Cheli-ka piano-lul kuliko Yenghi-ka violin-ul
 Cheli-nom piano-acc conj Yenghi-nom violin-acc
 [cal-**tul** yencwuhay-ss-ta]
 well-DPM play-pst-decl

‘Cheli played the piano well and Yenghi played the violin well.’

b.*Cheli-ka piano-lul cal-**tul** yencwuhay-ss-ta kuliko
 Yenghi-ka violin-ul cal-**tul** yencwuhay-ss-ta

(37)a. Cheli-ka cangmi-lul kuliko Yenghi-ka CD-lul
 Cheli-ka rose-acc conj Yenghi-nom CD-acc
 [**selo-eykey** senmwul-lo cwu-ess-ta]
 each.other-dat present-as give-pst-decl

‘Cheli gave roses to Yenghi and she gave CD to him as a present.’

b.*Cheli-ka cangmi-lul **selo-eykey** senmwul-lo cwu-ess-ta
 Yenghi-ka CD-lul **selo-eykey** senmwul-lo cwu-ess-ta

(38)a. Cheli-ka mwunhak-ul kuliko Yenghi-ka enehak-ul
 Cheli-nom literature-acc conj Yenghi-nom linguistics-acc
 [**kakkak** yelsimhi kongpwuhay-ss-ta]
 respectively hard study-pst-decl

‘Cheli and Yenghi studied literature and linguistics hard respectively.’

b. *Cheli-ka mwunhak-ul **kakkak** yelsimhi kongpwuhay-ss-ta kuliko
 Yenghi-ka enehak-ul **kakkak** yelsimhi kongpwuhay-ss-ta

To resolve DPM licensing and RM in RNR constructions, D-H Chung (2004) proposed Multi-dominance analysis as in (39). (McCawley 1982, Wilder 1999). As the analysis links two subjects to one predicate, it allows RM ‘kakkak’ and DPM ‘tul’ to be licensed in RNR constructions. Specifically, he follows assumptions of Wilder’s (1997, 1999) multiple dominance analysis - Coordination is asymmetric and the apparently ‘RNRed’ part is shared by both conjuncts. Wilder’s Multi-Dominance analysis, with some modification of c-command and

image of Kayne's Linear Correspondence Axiom, is able to solve licensing of RM and DPM in RNR constructions without violating Kayne's (1994) Linear Correspondence Axiom (LCA). LCA states that [1] asymmetric c-command between two categories maps to precedence between a pair of sets of terminals and that [2] the mapping is mediated by the concept of the image of a category, such that the set of terminals that is the image of one category, X, precedes the set of terminals in the image of another, Y, which X asymmetrically c-commands. Wilder's 1999 modified notion of c-command and image are as follows. X c-commands Y only if X does not fully dominate Y. $d(X)$ = the (unordered) set of terminals fully dominated by X. As we see in (39), the irreflexivity requirement is fulfilled since VP is neither in $d(TP1)$ nor in $d(TP2)$ since neither TP1 nor TP2 fully dominates VP. TP1 c-commands into VP, guaranteeing that elements in TP1 (except for VP) precede the terminals of VP. Chung thus claims that as the two subjects have a shared predicate with no linearization problem, both RM and DPM are successfully licensed.

(39)

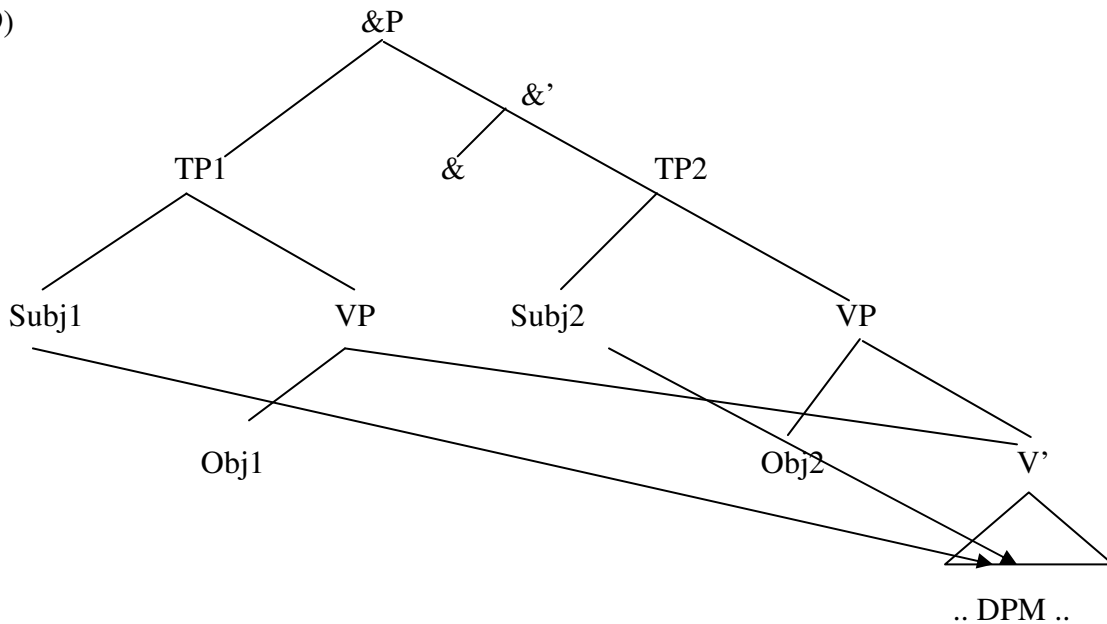

2.2.2 Problems

D-H Chung (2004), though insightful in the sense that it observed interesting empirical phenomena, is not plausible; since the subject in each conjunct is singular and not plural, we cannot say that the RM and PDE, in this example, are licensed by a plural antecedent.

Additional problems for the MD Analysis include morphological mismatches and strict/sloppy readings of pronouns. Morphological mismatches have been observed by many researchers (Boskovic 1995, 2005, D-H Chung 2004, M-K Park 2006, Ahn and Cho 2006b). (40) shows mismatches in inflectional morphemes and (41), mismatches in honorific morphemes and (42-43), mismatches in case morphology¹⁸ (cf. Ahn and Cho 2006).

(40)a. ?John will ~~sleep in his house~~, but Mary probably was – sleeping in his office.

b. John will ~~sleep in his office~~, and Peter already has – slept in his office.

c. John hasn't ~~questioned our motives~~, but Bill may be – questioning our motives.

d. John has ~~slept in his office~~, but Peter definitely will – sleep in his office.

(41) John-i chayk-ul kuliko halapeci-kkeyse sinmwun-ul
John-nom book-acc conj Grand.father-hon.nom newspaper-acc
ilk-**usi**-n-ta
read-hon-pres-decl

'John reads a book and his grandfather reads a newspaper.'

= John-i chayk-ul ilk-**nun**-ta kuliko
John-nom book-acc read-pres-decl conj

¹⁸ This is problematic under MD as it is commonly assumed that various case alternations occur due to structural differences. As MD posits the same structure between the shared part of the first and the second conjunct, the case alternation patterns between the first and the second conjunct are not predicted.

Halapeci-kkeyse sinmwun-ul ilk-**usi-n**-ta
 Grand.father-hon.nom newspaper-acc read-hon-pres-decl

‘John reads a book and his grandfather reads a newspaper.’

(42) John-un Osaka-**lul** kuliko Mary-nun Tokyo-**ka** ka-ko siph-ess-ta
 J-Top Osaka-acc conj M-Top T-nom go-comp want-pst-dcl

‘John wanted to go to Osaka and Mary wanted to go to Tokyo’

= John-un Osaka-**lul** ka-ko siph-ess-ta kuliko
 Mary-nun Tokyo-**ka** ka-ko siph-ess-ta

(43) John-un Osaka-**ka** kuliko Mary-nun Tokyo-**lul** ka-ko siph-ess-ta
 J-Top Osaka-nom conj M-Top T-acc go-comp want-pst-dcl

‘John wanted to go to Osaka and Mary wanted to go to Tokyo’

= John-un Osaka-**ka** ka-ko siph-ess-ta kuliko
 Mary-nun Tokyo-**lul** ka-ko siph-ess-ta

In addition, sloppy and strict readings are not expected under Multi-dominance analysis. Specifically, (44) has two readings – both strict and sloppy readings. As pointed out by S-W Ha (2006), the MD analysis is problematic for the following reasons. Ha (2006) claims that the MD analysis of RNR constructions can account for strict and third party reading, but not a sloppy reading in sentences such as (44). Under Ha’s account of MD analysis, ‘his’ in the shared part should be co-indexed with both ‘John’ and ‘Tom’ simultaneously. However, as the semantics of the Multi-dominance analysis has not been provided in previous studies (McCawley 1982, Wilder 1999 etc.), we cannot exactly tell what the intended interpretation of the structure should be.

(44) **John**-un 9-si-ey kuliko **Tom**-un 10-si-ey
 John-top 9-time-at and Tom-top 10-time-at
 [ku-uy cip-ulo ka-ss-ta]
 his home-to go-past-decl

a. John went to Tom's house at 9:00 and Tom went to Tom's house at 10:00. (Strict reading)

b. John went to John's house at 9:00 and Tom went to Tom's house at 10:00. (Sloppy reading)

As multi-dominance analysis also has non-trivial problems, another non-movement analysis 'Deletion under Identity' has been proposed, which will be reviewed in the next subsection.

2.3 Deletion under Identity Analysis (Kayne 1994, Wilder 1997, Hartmann 2000, S-W Ha 2006, 2007)

Ellipsis based on strict phonetic identity has been criticized (D-H Chung 2004, Yoon and Lee 2005, S-W Ha 2006 etc.) widely in both Korean and English mainly because sometimes non-identical elements can be deleted as we have discussed previously. For morphological Mismatches, see examples (40-43) and for Licensing of RMs and DPM, see examples (36-38).

2.3.1 Deletion under Semantic Identity: How it works

Deletion under semantic identity (S-W Ha 2006, 2007) is the latest proposal regarding RNR constructions in Korean and seems to be plausible in the sense that it is not based on the ellipsis under "phonetic identity" but on the ellipsis under "semantic identity".

S-W Ha (2006) adopts the Semantic Licensing Condition (45) on ellipsis, following Merchant

(2001). He specifically proposes that the Licensing Condition for RNR constructions is more dependent on semantic identity: a mutual entailment relationship between the antecedent and the elided part must be established at LF for RNR be licensed. The main reason he is proposing Semantic Licensing Condition is to allow various mismatches between the target in the first conjunct and the antecedent in the second conjunct by proposing an ellipsis based on semantic identity (that is, mutual entailment). In other words, after the existential closure of the focus constituents (F-closure) in (46a-c), the antecedent and the elided part are semantically identical. As a result, A entails F-clo (E) and E entails F-clo (A), so the RNR is licensed.

(45) e-GIVEN

An expression E counts as e-given iff E has a salient antecedent A and, modulo E-type shifting

- (i) A entails F-clo (E), and
- (ii) E entails F-clo (A)

(46) [_{TP1}[Sue-ka]_F [yaku-lul]_F <hanta>], kuliko [_{TP2}[Mary-ka]_F [nongkwu-lul]_F hanta].

Sue-nom baseball-acc ~~do~~ Mary-nom basketball-acc do

- a. A= SUE-NUN YAKWU-LUL hanta
- b. E= MARY-NUN NONGKWU-LUL hanta
- c. F-clo(A) = F-clo (E) = $\exists x. \exists y. x$ did y

He further proposes syntactic rule (47) and phonological rule (48). Following Merchant (2001), Focus can bear an E feature as in (47) – Ellipsis feature that instructs PF not to pronounce its complement as stated in (48).

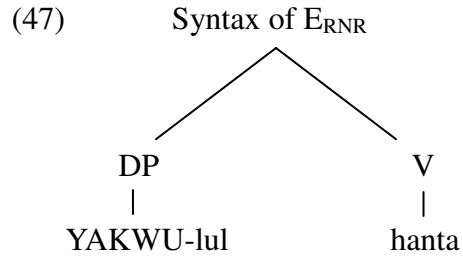

(48) Phonology of E_{RNR}

$$XP (s) \rightarrow \emptyset / E_{RNR} \text{ _____ }]_{TP1}$$

What is novel about his analysis is that under his view, RNR need not delete material on the right edge of the initial conjunct. Indeed, he takes (49), where the apparently deleted material in the initial conjunct is not on the right edge, to be an instance of RNR, analyzed as in (50).

(49) John-un ~~ku cha-lul~~ phal-ass-ko Mary-nun ku cha-lul sa-ss-ta
 J-Top the car-acc sell-past-conj Mary-Top the car-acc buy-past-decl
 ‘John sold and Mary bought the car’

(50) [$_{TP1}$ [JOHN-un]_F <~~ku cha-lul~~> [PHAL-ASS-]_F-ko]
 [$_{TP2}$ [MARY-nun]_F ku cha-lul [SA-SS-TA]_F]

Again, it meets the semantic conditions stated in (51). Specifically, after existential closure of the focus constituents (F-closure), the antecedent and the elided part are semantically identical as in (51c). As a result, A entails F-clo (E) and E entails F-clo (A). Then, E_{RNR} (ellipsis feature) enters the derivation with the contrastively focus-marked element, so the RNR is licensed in PF.

(51) Semantic Condition: Mutual Entailment Condition

- a. Ante = [MARY-nun]_F ku cha-lul [sa-ss-ta]_F
- b. RNR = [JOHN-un]_F <~~ku-cha-lul~~> [pal-ass-]_F
- c. F-clo(A) = F-clo (E) = $\exists x. \exists R. [x R\text{-}ed \text{ the car.}]$

2.3.2 How it solves the problems with the MD analysis

Unlike MD analysis, this analysis allows both strict and sloppy reading. As the analysis is deletion, it has the ellipsis site [e] in the first conjunct. So, by giving a different index to the ellipsis site, we can obtain a sloppy reading as well.

(24) **John-un** 9-si-ey e kuliko **Tom-un** 10-si-ey
 John-top 9-time-at and Tom-top 10-time-at
 [ku-uy cip-ulo ka-ss-ta]
 his home-to go-past-decl

- a. John went to Tom’s house at 9:00 and Tom went to Tom’s house at 10:00. (Strict reading)
- b. John went to John’s house at 9:00 and Tom went to Tom’s house at 10:00. (Sloppy reading)

Despite some advantages of this semantic licensing of RNR, it has some problems, which will be discussed in 2.3.3.

2.3.3 Problems

2.3.3.1 Over-generation

This section points out problems with deletion under semantic identity (Ha 2006, 2007). In the beginning, Ha’s analysis faces the problem of over-generation of RNR since it deletes whatever elements are next to the contrastively focus-marked element bearing E_{RNR} feature. That is, it predicts (25a-b) to be a well-formed RNR construction. In (25a), *Mary-ka* is next (a sister) to the

contrastively focused element *khun soli-lo* and should be able to undergo deletion. In a similar fashion, in (25b), *cheum-ey* and *nolayhay-ss-ta* bear contrastive focus and should license the deletion of both *Mary-ka* and *cakun soli-lo* since they are adjacent to the contrastively focused elements.

(25)a. *~~Mary-ka~~ khun soli-lo malhay-ss-ko
 Mary-nom in a loud voice say-Pst-conj
 Mary-ka cakun soli-lo nolayhay-ss-ta
 Mary-nom in a low voice sing-Pst-decl
 ‘Mary spoke in a loud voice and sang in low voice’

b. *~~Mary-ka~~ cheumey ~~cakun soli-lo~~ nolayhayssko
 Mary-nom at first in.a.low.voice sang.and
 Mary-ka nacwung-ey cakun soli-lo malhay-ss-ta
 Mary-nom later-at in.a.low.voice say-Pst-decl
 ‘At first Mary sang in a low voice and later Mary spoke in a low voice’

In a similar respect, some constraint is needed to rule out cases such as (26), where, after the existential closure of the focused elements in the antecedent and the target, the two entail each other as in (28) and ellipsis (RNR) should be licensed here, contrary to fact.

(26) Yenghi-ka sakwa-lul coaha-ko Cheli-ka pay-lul silheha-n-ta
 Yenghi-nom apple-acc like-conj Cheli-nom pear-acc dislike-pres-decl
 ‘Yenghi likes apples and dislikes pears.’

(27) Semantic Condition: Mutual Entailment Condition

a. Ante = [Cheli-ka]_F [pay-lul]_F [silheha-n-ta]_F

b. RNR = [Yenghi-ka]_F [sakwa-lul]_F [coaha-n-ta]_F

c. F-clo(A) = F-clo (E) = $\exists x. \exists y. \exists R. [x R\text{-pres } y.]$

(28) F-clo (A) = { Yenghi likes apples, Cheli likes pears, Yenghi likes pears, Cheli dislikes pears,
Cheli dislikes apples, Tongswu dislikes bananas etc. }

F-clo (E) = { Yenghi likes apples, Cheli likes pears, Yenghi likes pears, Cheli dislikes pears,
Cheli dislikes apples, Tongswu dislikes bananas etc. }

2.3.3.2 Some ad hoc mechanism for the licensing of DPM and RM

Other than the overgeneration problem, Ha provides some stipulative account of the Licensing of DPM *-tul* and RM *-kakkak* in RNR constructions. He then deals with potential problems for the MD account as follows. First, he argues against the claim that any deletion account cannot deal with RNR structures, involving DPM and RMs. He proposes that DPM *-tul* makes no semantic contribution, having no influence on entailment relationships between the conjuncts. Thus he provides the following structure for sentences with *-tul*, with *-tul* only in the second conjunct. So, TP_A and TP_E symmetrically entail each other as in (29).

(29) [TP_E Sue-nun yaku-lul eal-~~Ø~~-han-ta]

Sue-top baseball-acc

kuliko [TP_A Jane-un nongku-lul cal-**tul** han-ta
and Jane-top basketball-acc well-**DPM** do-dec

‘Sue plays baseball well and Jane plays basketball well.’ (DPM: dummy plural marker)

TP_A= Jane plays basketball well-DPM. F-clo(TP_A)= ∃ x. ∃ y. y plays x well-DPM

TP_E= Sue plays baseball well-∅. F-clo(TP_E)= ∃ x. ∃ y. y plays x well-∅

TP_E can entail F-clo(TP_A) and TP_A can entail F-clo(TP_E), satisfying Merchant’s e-Givenness.

Then, he assumes that *the DPM looks for clause-mate subjects*. Clause boundary is indicated by a Complementizer. In (29), the conjunction occurs at the vP or TP level (Yoon 1994) and here he assumes that it is vP coordination. The CP in (29) contains plural subjects – one in the first conjunct and another in the second. Thus, the DPM in the second conjunct is licensed.

However, his analysis is problematic, considering the following example (30). He assumes that the DPM is successfully licensed when it is adjoined at vP coordination, which predicts (30) to be acceptable. Specifically, when we compute the mutual entailment relationship, we ignore *-tul* as it has no semantic contribution. Then, each conjunct, after the existential closure of the focused elements, entails each other and RNR is licensed. Then, *-tul* looks for clause-mate subjects and still it has two subjects within the coordination vP, being successfully licensed. Data (30), however, is not acceptable, falsifying his prediction.

(30) *[TP_E Sue-nun yaku-lul wuntongcang-eyse-**tul** ~~han-ta~~ kuliko
 Sue-top baseball-acc in.the.playground-**DPM** and

[TP_A Jane-un nongku-lul kongwon-eyse han-ta
Jane-top basketball-acc in.the.park do-dec

‘Sue plays baseball in the playground and Jane plays basketball in the park.’

Second, he accounts for the modification of RM ‘kakkak’ by assuming that it adjoins outside the conjunct. So, the overt RM is not in the first conjunct before ellipsis as in analysis (31b). To make the two conjuncts entail each other so the deletion occurs, the verb was present in the initial conjunct and at that point, the focus closure of each conjunct entails each other. Then, the verb in the initial conjunct is deleted and the verb in the second conjunct moves out of it to get a correct word order.

(31)a. Mary-ka chayk-ul kuliko John-i sinmun-ul
Mary-nom book-acc and John-nom newspaper
kakkak ilk-ess-ta
respectively read-past-decl

‘Mary read book and John read newspaper respectively.’

b. [TP₁ MARY-ka CHAYK-ul il-ess]-(ta), (kuli)ko [TP₂ JOHN-i SINMUN-ul t_v]
kakkak ilk-ess-ta

c.

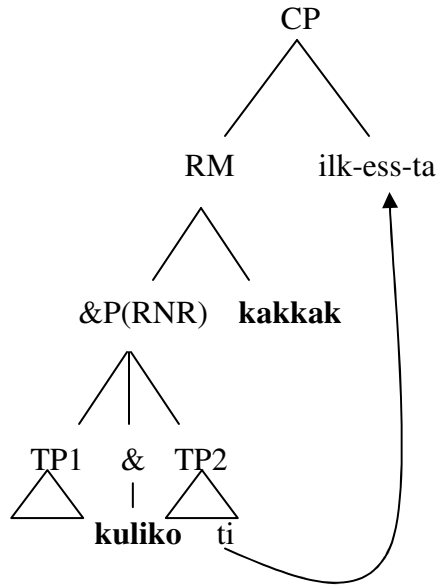

Here, as to RM ‘kakkak’, he is making an assumption that the verb in the second conjunct is forced to **move** out of the final conjunct in a non-ATB fashion to get the correct word order in a sentence.

This movement analysis is *ad hoc* considering that in any other RNR/Gapping constructions, the verb does not need move out of the final conjunct at all. This movement mechanism is necessary for the RM constructions only to derive a correct word order.

In sum, the MD account faces problems in accounting for various mismatches between the antecedent and the target in RNR and explaining strict/sloppy readings. The PF deletion based on semantic identity also has over-generation problem as well as an ad hoc mechanism to explain all the main constructions.

3. An Alternative Analysis

3.1 Incremental C-selectional Combinatoric Analysis of RNR constructions

We propose an alternative approach of RNR, where RNR does not involve MD or deletion. With

the system proposed in chapter 2, we attempt to provide Incremental C-selectional Combinatoric Analysis of RNR. In RNR constructions, the initial conjunct is missing a predicate on the surface. When an overt predicate is not present, a null VP of the right class, [e], is licensed, as a form of ‘predicate drop’, similar to ‘pro-drop’ of arguments in other languages. Since the null predicate does not have its content, when the second conjunct is parsed and a compatible predicate is encountered, the content of that predicate is unified with that of the null predicate in the first conjunct. Thus, there is no MD or literal deletion in this system. This ‘predicate drop’ phenomenon in RNR is attested in constructions outside of RNR. Specifically, it was observed in argument cluster coordinations, fragments and clefts in Korean (Y-J Choi 2007) and does not need to be stipulated. Let us consider how RNR constructions as in (32) are analyzed under the proposed system. Specifically, it is analyzed as in (33) where the initial conjunct licenses a null predicate. The contents of this null predicate are resolved by the overt predicate in the final conjunct as both predicates belong to the same Verb Class -- Verb Class 2 according to verb classification in Chapter 2. Verb Class 2 is licensed by the combination of a nominative KP and an accusative KP.

- (32)[Yenghi-ka ttek-ul] Δ_i kuliko [Cheli-ka ppang-ul] **mek_i**-ess-ta
 Y-nom rice.cake-acc conj Cheli-nom bread-acc eat-past-decl
 ‘Y ate rice cake and C ate bread’

(33)

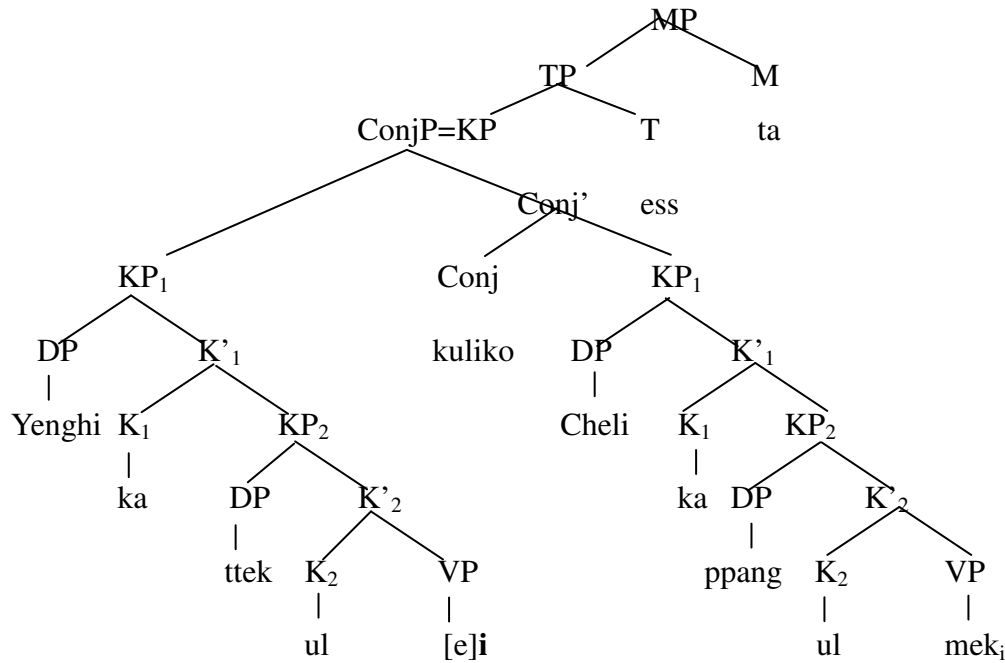

Let us consider cases where the conjuncts involve an adverb as in (34).

(34)[Yenghi-ka	ttek-ul	chenchenhi]	Δ_i	kuliko
Y-nom	rice.cake-acc	slowly		conj
[Cheli-ka	ppang-ul	ppalli]	mek_i -ess-ta	
Cheli-nom	bread-acc	fast	eat-past-decl	

‘Yenghi ate rice cake slowly and Cheli ate bread fast.’

As the head K always requires some verbal complements (another KP or VP) as its complement, and as KPs are basically the same as VPs under the proposed system, adverbs can freely adjoin KPs or VPs, and do not affect determining verb classification of the following predicate. Example (34) thus is analyzed as depicted in (35).

(35)

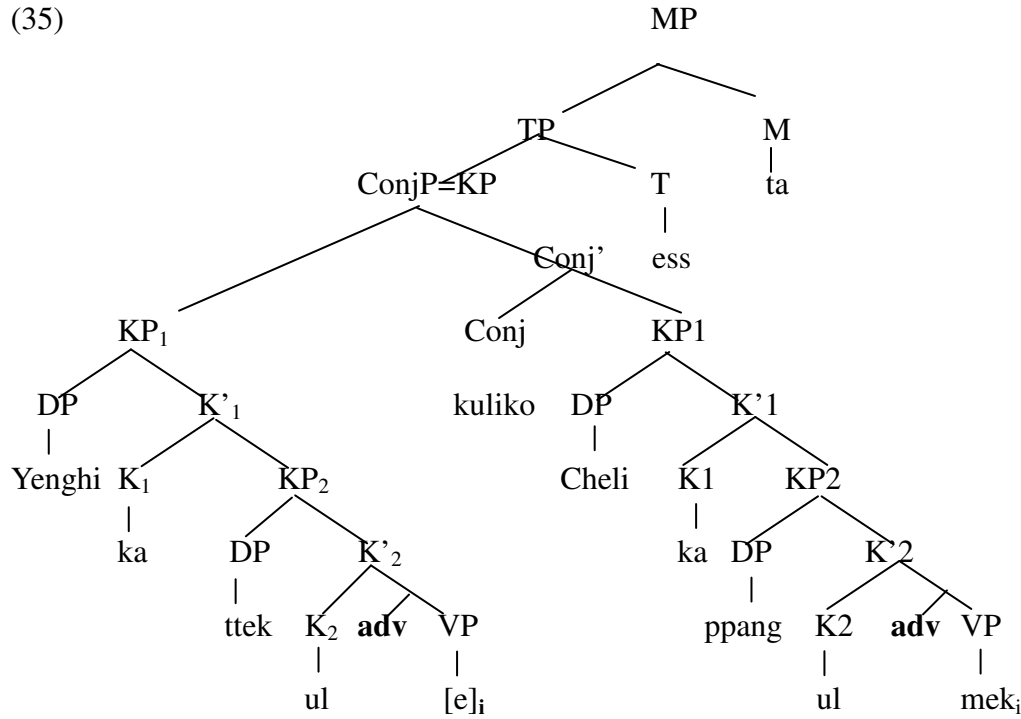

Cases involving RMs and DPMs are analyzed differently than normal RNR constructions. In this case, the predicate *excluding* RM and DPM is unified with the null predicate in the initial conjunct. (36) is analyzed as in (37).

(36)Cheli-ka	cangmi-lul	kuliko	Yenghi-ka	CD-lul
Cheli-ka	rose-acc	conj	Yenghi-nom	CD-acc
selo-eykey	senmwul-lo	cwu-ess-ta		
each.other-dat	present-as	give-pst-decl		

‘Cheli gave roses to Yenghi and she gave CD to him as a present.’

(37)Cheli-ka	cangmi-lul	[senmwul-lo	cwu-ess-ta]	kuliko
Cheli-ka	rose-acc	present-as	give-pst-decl	

Yenghi-ka	CD-lul	[senmwul-lo	cwu-ess-ta]
Yenghi-nom	CD-acc	present-as	give-pst-decl
selo-eykey	senmwul-lo	cwu-ess-ta	
each.other-dat	present-as	give-pst-decl	

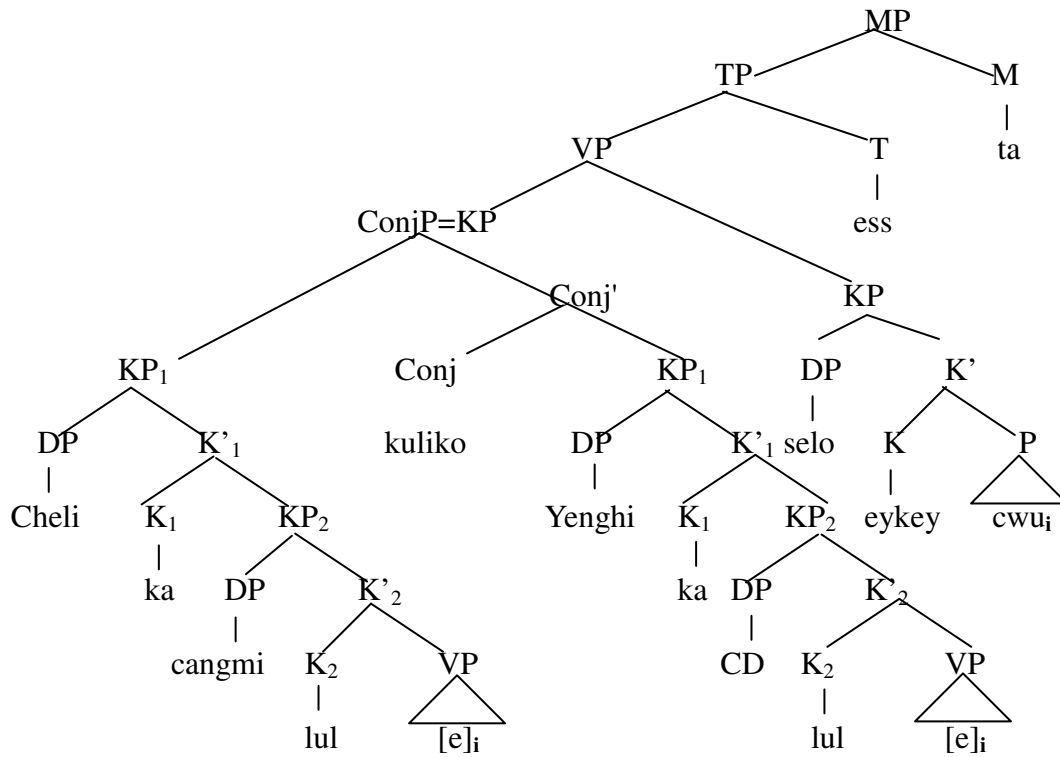

Likewise, (38) is analyzed as in (39).

(38) Cheli-ka kuliko Yenghi-ka **kakkak** cip-ulo ka-ss-ta
 Cheli-nom conj Yenghi-nom respectively house-to go-pst-decl
 ‘Cheli and Yenghi went home respectively.’

(39) Cheli-ka [cip-ulo ka-ss-ta] kuliko Yenghi-ka [cip-ulo ka-ss-ta]
kakkak cip-ulo ka-ss-ta

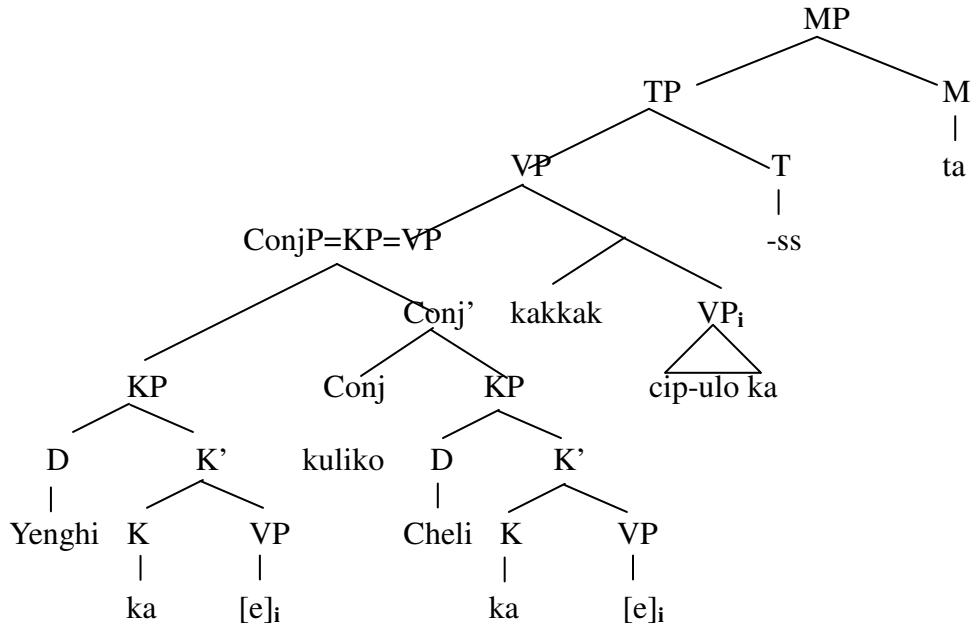

(40) is analyzed as in (41).

(40) Cheli-ka piano-lul kuliko Yenghi-ka violin-ul
 Cheli-nom piano-acc conj Yenghi-nom violin-acc
 cal-**tul** yencwuhay-ss-ta
 well-PDM play-pst-decl
 ‘Cheli played the piano and Yenghi played the violin well.’

(41) Cheli-ka [piano-lul yencwuhay-ss-ta] kuliko
 Yenghi-ka [violin-ul yencwuhay-ss-ta]
 cal-**tul** yencwuhay-ss-ta

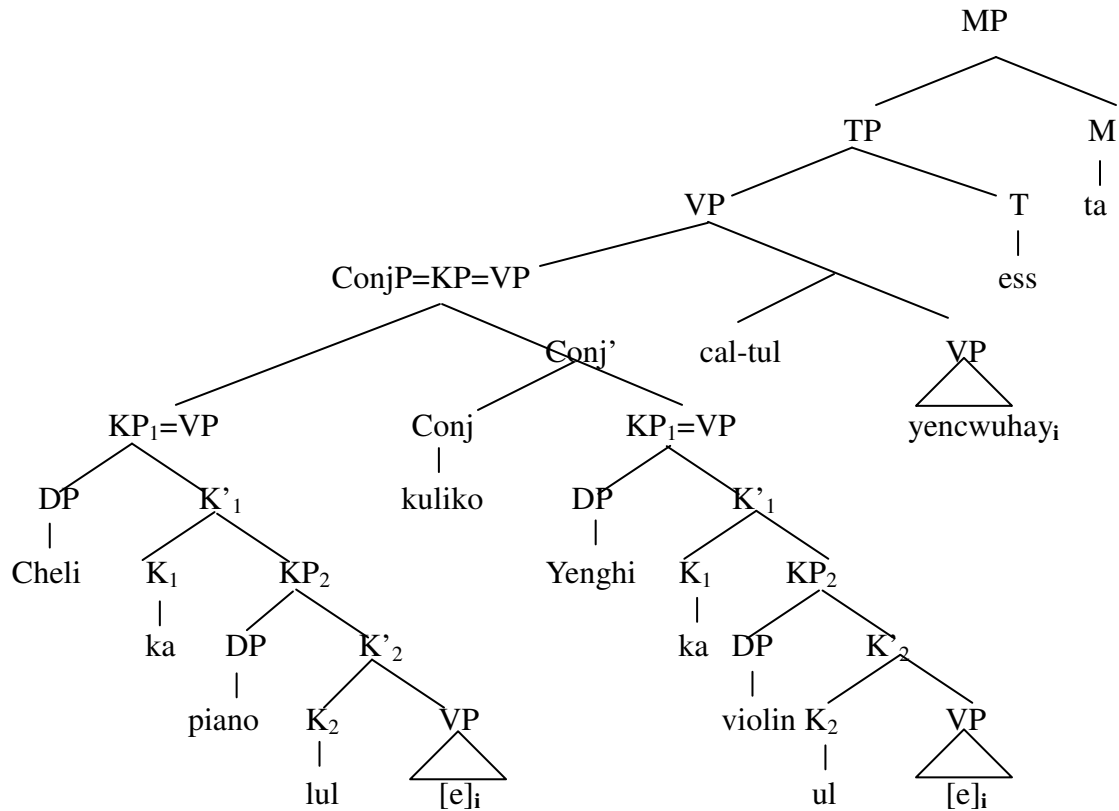

This analysis is consistent with Carlson’s (1987) constraint that expressions which presuppose the existence of multiple entities *may not surface inside their licensing coordinate complexes*.¹⁹ (See Ahn and Cho (2006b) and Y-H Kim (2007) for other multiple fragment analyses of RNR constructions and Multiple Accusative Constructions respectively.)

In sum, there are two options of getting RNR – one where the second conjunct does not have a null predicate, and another where there is a null predicate in the second conjunct and the shared string scopes over both conjuncts.

¹⁹ Carlson’s constraint was originally made regarding similarity expressions such as *same*, *similar*, *equal* and *different*. However, relational modifiers and DPM can be regarded as being in the same group as those elements in the sense that all the elements presuppose plural entities or plural eventualities.

3.2 Predicate Identity Requirement

In the proposed system, predicate in the initial conjunct is unified with that of the final one as long as the KP cluster and the predicate match in terms of syntactic type, taking the classification of verbs into account, depending on valence classes. Then, can any part of the final/overt predicate be unified with the null predicate in the initial one without getting constrained? To answer this question, this subsection considers what requirement need be satisfied to derive acceptable interpretations. Crucially, predicate in the initial conjunct is unified with that of the final one to the extent that no semantic anomaly results. For example, (42) can have two interpretations as in (42a-b), and (42c) is out due to semantic anomaly.

- (42) Cheli-ka yelsimhi hakkyo-eyse kuliko Yenghi-ka cip-eyse
 Cheli-nom hard school-at conj Yenghi-nom house-at
 Chinkwu-wa keyulli sukcey-lul hay-ss-ta
 with.a.friend idly homework-acc do-pst-decl
- a. Cheli-ka yelsimhi hakkyo-eyse sukcey-lul hay-ss-ta kuliko
 Yenghi-ka cip-eyse Chinkwu-wa keyulli sukcey-lul hay-ss-ta
- b. Cheli-ka yelsimhi hakkyo-eyse chinkwu-wa sukcey-lul hay-ss-ta kuliko
 Yenghi-ka cip-eyse Chinkwu-wa keyulli sukcey-lul hay-ss-ta
- c. * Cheli-ka yelsimhi hakkyo-eyse Chinkwu-wa keyulli sukcey-lul hay-ss-ta
 kuliko Yenghi-ka cip-eyse Chinkwu-wa keyulli sukcey-lul hay-ss-ta

Data (43) below display Multiple Subject Construction in RNR context and exhibit some similar points. (43) has three interpretations as there are three potential candidates for ‘Yenghi-lul’ to

combine with. Considering syntactic types, “hankwuk-i” can combine with any bracketed parts because all of them are compatible with “hankwuk-i” in terms of Type-Matching. So, they are potential predicate candidates for the initial conjunct. Specifically, first, when ‘hankwuk-i’ finds the predicate ‘casal-ywul-i noph-ta’ as it is one of the compatible predicate candidates, it gets the interpretation (a). Second, when ‘hankwuk-i’ meets the predicate ‘yehaksayng-i casal-ywul-i noph-ta’, it gets the interpretation (b). Third, when ‘hankwuk-i’ grabs the predicate ‘kotunghaksayng-iyehaksayng-i casal-ywul-i noph-ta’, it gets the interpretation (c).

(43)hankwuk-i kuliko ilpon-i [kotunghaksayng-i
 Korea-nom conj japan-nom high.school.student-nom
 [yehaksayng-i [casal-ywul-i noph-ta]]
 female.student-nom suicide-rate-nom be.high-decl

a) hankwuk-i/ **PRED** kuliko/ ilpon-i/

Korea-nom conj japan-nom
 kotunghaksayng-i yehaksayng-i casal-ywul-i noph-ta
 high.school.student-nom female.student-nom suicide-rate-nom be.high-decl

‘The suicide rate of female high school student in Korea and the suicide rate of female high school student in Japan are high’

b) hankwuk-i/ **PRED** kuliko/ ilpon-i kotunghaksayng-i /

Korea-nom conj japan-nom high.school.student-nom
 yehaksayng-i casal-ywul-i noph-ta
 female.student-nom suicide-rate-nom be.high-decl

‘The suicide rate of female student in Korea and the suicide rate of female high school

student in Japan are high'

- c) hankwuk-i/ **PRED** kuliko/ ilpon-i kotunghaksayng-i
 Korea-nom conj japan-nom high.school.student-nom
 yehaksayng-i / casal-ywul-i noph-ta
 female.student-nom suicide-rate-nom be.high-decl

'The suicide rate in Korea and the suicide rate of female high school student in Japan are high'

Specifically, in the structure below, when the null predicate [e] in the first conjunct is unified and co-indexed with VP_i in the second conjunct with an overt predicate, it gets the interpretation (43a). When unified with VP_j , it has the reading (43b). When with VP_h , it obtains the reading (43c).

[the first conjunct]

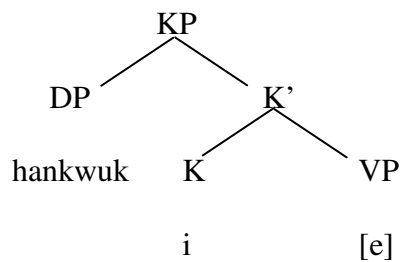

[the second conjunct]

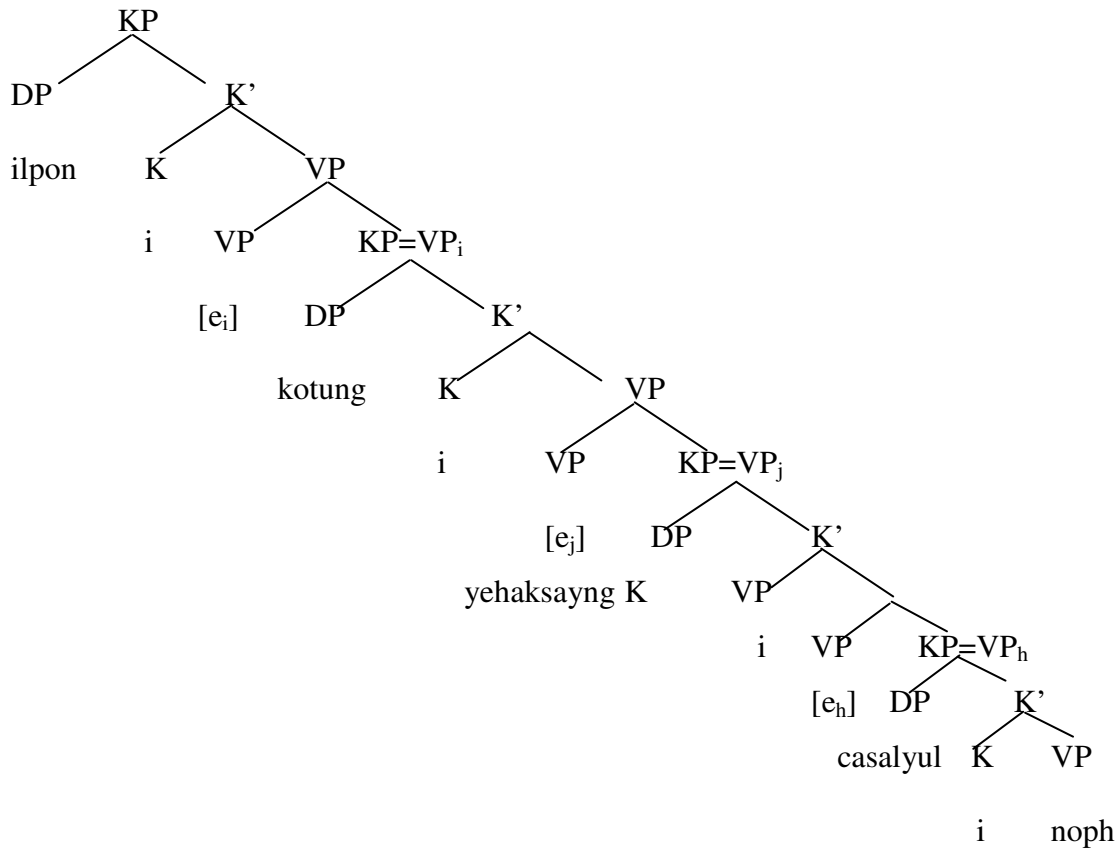

Of course, there are cases where type matches, but data are unacceptable due to “semantic anomaly”. In (45), the nom subject ‘hankwuk-i’ can find ‘tongkyeng-i kotunghaksayng-i yehaksayng-i casal-ywul-i noph-ta’ as its compatible predicate since the type matches, but this interpretation is ruled out due to semantic anomaly.

(45)hankwuk-i kuliko ilpon-i [tongkyeng-i [kotunghaksayng-i
 Korea-nom conj japan-nom Tokyo-nom high.school.student-nom
 [yehaksayng-i [casal-ywul-i noph-ta]]]
 female.student-nom suicide-rate-nom be.high-decl

a) hankwuk-i/ **PRED** kuliko/ ilpon-i/ tongkyeng-i

Korea-nom conj japan-nom Tokyo-nom

kotunghaksayng-i yehaksayng-i casal-ywul-i noph-ta

high.school.student-nom female.student-nom suicide-rate-nom be.high-decl

‘The suicide rate of female high school student **in Tokyo in Korea** and the suicide rate of female high school student in Tokyo in Japan are high’

In conclusion, in this particular case, any bracketed parts can be the null predicate in the initial conjunct because Korean allows multiple object or subject constructions and the number of objects or subjects do not affect the predicate type that they are supposed to combine with. In a more general sense, the PRED in the initial conjunct should/can be co-indexed with any part of predicate in the second conjunct unless there is type or semantic mismatch. This furthermore accounts for morphological mismatch -- the fact that there is always an agreement between the final predicate and the final conjunct subject, but that the agreement is not necessarily observed between the final predicate and the non-final conjunct as in (46).

(46) John-i chayk-ul kuliko halapeci-kkeyse sinmwun-ul

John-nom book-acc conj Grand.father-hon.nom newspaper-acc

ilk-usi-n-ta

read-hon-pres-decl

‘John reads a book and his grandfather reads a newspaper.’

That is, when the null predicate in the initial conjunct is unified with the final predicate, the

honorific morpheme ‘si’ in the final predicate is not reconstructed to the initial predicate to avoid semantic anomaly.

4. Advantages

4.1 Problems with MD analysis do not occur

An advantage of this analysis is that it easily accounts for all the Non-Constituent RNR constructions through recovering the (missing) elements from the second/final conjunct. As the RNR construction involves a predicate in each conjunct in the proposed system, it does not face problems such as strict/sloppy identity that beset the MD analysis. Specifically, there is no problem with sloppy identity in (47), since we have two V(P)s in an RNR, as in the deletion analysis, but unlike the MD analysis.

(47) **John-un** 9-si-ey kuliko **Tom-un** 10-si-ey
John-top 9-time-at and Tom-top 10-time-at
[ku-uy cip-ulo ka-ss-ta]
his home-to go-past-decl

a. John went to Tom’s house at 9:00 and Tom went to Tom’s house at 10:00. (Strict reading)

b. John went to John’s house at 9:00 and Tom went to Tom’s house at 10:00. (Sloppy reading)

4.2 Morphological Mismatch

As previously mentioned, the system allows various mismatches between the target of deletion (RNR) in the first conjunct and the antecedent in the second conjunct as the null predicate in the

first conjunct need be identical to the predicate in the final conjunct only in terms of syntactic type. When the initial null predicate searches for a compatible predicate and it meets ‘ilk-usi-nta’, it is resolved to ‘ilk-(nu)n-ta’ as the honorific morpheme cannot be unified with the null predicate due to semantic anomaly. If the honorific morpheme ‘si’ is reconstructed in the initial conjunct, the subject ‘John-i’ does not agree with the honorific morpheme, so the derivation fails.

(48) a. John-i chayk-ul kuliko halapeci-kkeyse sinmwun-ul
 John-nom book-acc conj Grand.father-hon.nom newspaper-acc
 ilk-usi-n-ta
 read-hon-pres-decl
 ‘John reads a book and his grandfather reads a newspaper.’

b. John-i chayk-ul ilk-**nun-ta**
 John-nom book-acc read-pres-decl
 ‘John reads a book.’
 Halapeci-kkeyse sinmwun-ul ilk-**usi-n-ta**
 Grand.father-hon.nom newspaper-acc read-hon-pres-decl
 ‘His grandfather reads a newspaper.’

4.3 The (dis)ambiguity of constructions

As mentioned earlier, (49) is ambiguous and this ambiguity disappears in an RNR context as in (50).

(49)olhay-nun John-i manhun chinkwu-lul
 this.year-Top John-nom many friend-acc
 cip-ey chotayha-ci mos hay-ss-ta
 house-to invite Neg do-pst-decl

[*ambiguous* in a simple sentence]

‘There are many of John’s friends whom John did not invite to his house this year.’

‘It is not the case that John invited many friends to his house. He invited a few of his friends this year.’

(50)John-i manhun chinkwu-lul kuliko Mary-ka motun chinkwu-lul
 John-nom many friend-acc conj Mary-nom all friend-acc
 cip-ey chotayha-ci mos hay-ss-ta
 house-to invite Neg do-pst-decl

[*unambiguous* in an RNR context]

Specifically, (49) is ambiguous depending on whether the quantifier and the negation are in the same clause. When they are in the same clause, one scopes over the other and vice versa, resulting in ambiguity. However, when they are not in the same clause, scope interaction between the two is not possible and the sentence has only one reading. In this respect, sentence (50) is unambiguous as the quantifier and the negation are not in the same clause in the initial conjunct. The proposed system explains this since there is a null predicate in the initial conjunct, separating the quantifier from the negation. Thus, they cannot be in the same clause, which makes it impossible for the two elements to interact in terms of scope relations.

5. Extension of the Analysis to CoRNR Constructions

Providing a unified analysis for both RNR and CoRNR constructions is more challenging as the issues involved in CoRNR constructions are more complicated as we will see in the next section in more detail. It is commonly assumed that RNR constructions have a string (whether it is a constituent or not) in the second conjunct which is shared by both conjuncts. However, there are some cases (both in English and Korean/Japanese) which seem to be RNR constructions but contain some parts in the pivot that are not completely shared by both conjuncts. Specifically, if we consider (51a), the bracketed part is the pivot, but the parts made bold are not shared by the two conjuncts. Instead, they are interpreted distributively with respect to the conjoined subjects 'Cheli-ka kuliko Yenghi-ka'. As the pivot part is in the form of coordination of two predicates, these constructions are called “Coordination Under RNR Constructions” (CoRNR by de Vos and Vicente 2005, hereafter).

(51)a. Cheli-ka kuliko Yenghi-ka [Tongswu-lul **coaha-ko silhehay-ss-ta**]

C-nom conj Y-nom T-acc like-conj hate-past-decl

'Cheli liked Tongswu and Yenghi hated Tongswu (respectively)'

b. Cheli-ka Tongswu-lul coahay-ss-ta

Yenghi-ka Tongswu-lul silhehay-ss-ta

Similar phenomenon can be found in English as in (52).

(52) [[John loves e] and [Peter hates e]] [Mary and Susan]

a. John loves Mary and Peter hates Susan (=52)

b. John loves Susan and Peter hates Mary (≠/≠ 52)

In this section, I will extend the ICCA to CoRNR constructions. Before discussing the analysis, I will present the previous works specifically proposed for CoRNR constructions (M-K Park 2006 and 2007, de Vos and Vicente 2005 among others), pointing out problems. Then I will provide an alternative, clausal structure-building analysis for the construction in question.

5.1 Previous Analyses of CoRNR Constructions

M-K Park (2006, 2007) examines CoRNR constructions in English/Korean and proposes what he calls a midway coordination analysis. Also, de Vos and Vincent (2005) provide Phillips-Citko's style analysis for English CoRNR Constructions. Sub-sections 5.1.1 and 5.1.2 introduce those previous proposals and point out the problems that they have.

5.1.1 M-K Park (2006, 2007)

Park observes that constructions such as (52-53) challenge both deletion and multi-dominance analyses. Specifically, as the pivot is not completely shared by both conjuncts, neither deletion nor multi-dominance analysis cannot account for this construction.

(52) John-i piano-lul (kuliko) Mary-ka nolay-lul
J-nom piano-acc conj M-nom song-acc
kakkak chi-ko pwulu-ess-ta
respectively play-conj sing-pst-decl
'John played the piano and Mary sang a song, respectively.'

(53) Bill-i TV-lul (kuliko) Susie-ka Radio-lul
 B-nom TV-acc conj S-nom Radio-acc
 kakkak po-ko tul-ess-ta
 respectively watch-conj listen.to-pst-decl

‘Bill watched TV and Susie listened to Radio, respectively.’

He proposes that RNR constructions start with two full clauses and end up with their two right edges undergoing coordination in the middle of its derivation. So, when the two right edges are identical, just one right edge is realized in the second conjunct as schematized in (54). When the two right edges are not identical, they are combined by the conjunctor *-ko*, yielding Co-RNR as schematized in (55).

(54) [[conjunct clause X] CONJ [conjunct clause X]]

: midway coordination – unified into one term

(55) [[conjunct clause X] CONJ [conjunct clause X and Y, respectively]]

: midway coordination – combined together

Even though his analysis seems to work for previous examples (52-53), it faces a difficulty accounting for example (56).

(56) John-i piano-lul (kuliko) Mary-ka nolay-lul
 J-nom piano-acc conj M-nom song-acc

(kakkak) yelsimhi-tul chi-ko pwulu-ess-ta
 respectively hard-DPM play-conj sing-pst-decl

‘John played the piano hard and Mary sang a song hard, respectively.’

Specifically, according to his analysis, (56) consists of two clauses (57a-b) as he proposes that RNR constructions start with two full clauses and end up with their two right edges undergoing coordination during its derivation. However, contrary to his prediction, each of (57a-b) is unacceptable due to the fact that the dummy plural marker has a singular subject in each conjunct.

(57)a. * John-i piano-lul yelsimhi-tul chi-ess-ta
 J-nom piano-acc hard-DPM play-pst-decl
 b. * Mary-ka nolay-lul yelsimhi-tul pwulu-ess-ta
 M-nom song-acc hard-DPM sing-pst-decl

5.1.2 de Vos and Vicente (2005)

The other proposal on CoRNR constructions is by de Vos and Vicente (2005) based on Phillips-Citko. de Vos and Vicente assume that RNR and CoRNR constructions are the same except that the latter contains one extra coordination as exemplified in (58). So, they analyse the construction in question in the same way as Phillips-Citko’s analysis for RNR constructions.

- (58)a. John loves and Peter hates Mary
 b. John loves and Peter hates Mary and Susan.

Specifically, to account for the construction (59), structure (60) is proposed, following Phillips-Citko's analysis for RNR constructions.

(59)[[John loves e] and [Peter hates e]] [Mary and Susan]

- a. John loves Mary and Peter hates Susan (=1)
- b. John loves Susan and Peter hates Mary (≠ 1)

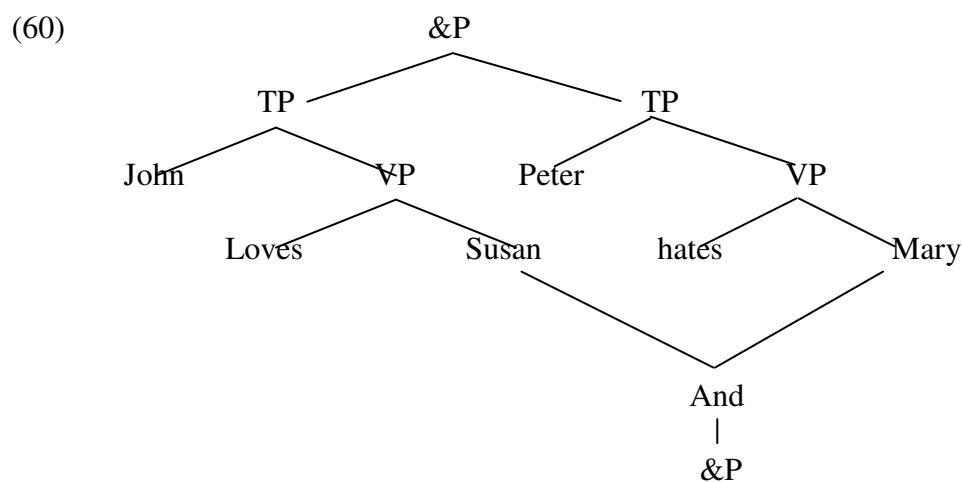

de Vos and Vicent (2005) argue that CoRNR sentences are the result of a PF mechanism that applies as a last resort to linearize a structure that would otherwise be unlinearizable. This string is exceptionally pronounced at the right edge of the utterance, giving rise to a CoRNR sentence. The Conjunct Adjacency Constraint (61) is also proposed for the correct linearization.

(61) In a coordinate structure, the coordinator must be linearly adjacent to (parts of) both conjuncts

Though their argument seems to work for the account of (62a-b), examples (62a-b) pose a problem for the analysis as pointed out in Vos and Vicent (2005). Specifically, their analysis predicts (62b) should be acceptable, which is not the case.

- (62) a. [John and Peter] love [Susan and Mary] (respectively)
 b.* [John and Peter] loves [Susan and Mary]

In addition, as to examples with PDEs, this analysis faces the same problem as Park’s because it also posits two full clauses and then conjoins the final element of each conjunct.

5.2 Incremental C-selectional Combinatoric Analysis for CoRNR Constructions

As RNR and CoRNR constructions are closely related, we extend our ICCA to CoRNR constructions. Crucially, as previously discussed, there are two options of getting RNR – one where the second conjunct does not have a null predicate, and another where there is a null predicate in the second conjunct and the shared string scopes over both conjuncts. The latter instance applies to RNR constructions with relational modifiers such as *selo* ‘each other’, *kakkak* ‘respectively’ etc. In addition, we propose that the presence of the relational modifiers ‘respectively’²⁰ in Co-RNR Constructions always requires a null predicate be posited in the second conjunct as well. Consider (63).

- (63) Cheli-ka sakwa-lul kuliko Yenghi-ka banana-lul **kakkak**
 C-nom apple-acc conj Y-nom banana-acc respectively

²⁰ Sometimes the RM is covertly realized, but still serves to set a pairwise relation between two ordered pairs of objects.

coaha-ko silhehay-ss-ta

like-conj dislike-pst-decl

‘Cheli liked apple and Yenghi disliked banana’

Let me walk you through the derivation of (63) as illustrated in (64). First, the KPs combine and then search for a compatible predicate in the initial conjunct, licensing a null predicate [e]. The search continues in the second conjunct until it encounters the overt predicate ‘coaha-ko silhehay-ss-ta’. As mentioned by Park (2006), the relational modifier ‘respectively’ serves to set a pairwise relation between two ordered pairs of objects. That is, the first conjunct of the example is related to the first conjunct of the conjoined predicate while the second conjunct, the second one of the conjoined predicate. Accordingly, the null predicate in the initial conjunct is unified with just the initial conjunct of the conjoined overt predicate and resolved to ‘coahata’ as depicted in (64). The null predicate [e] in the second predicate is then resolved to ‘silhehata’. Now we obtain the interpretation that Cheli liked apple and Yenghi disliked banana.

(64)

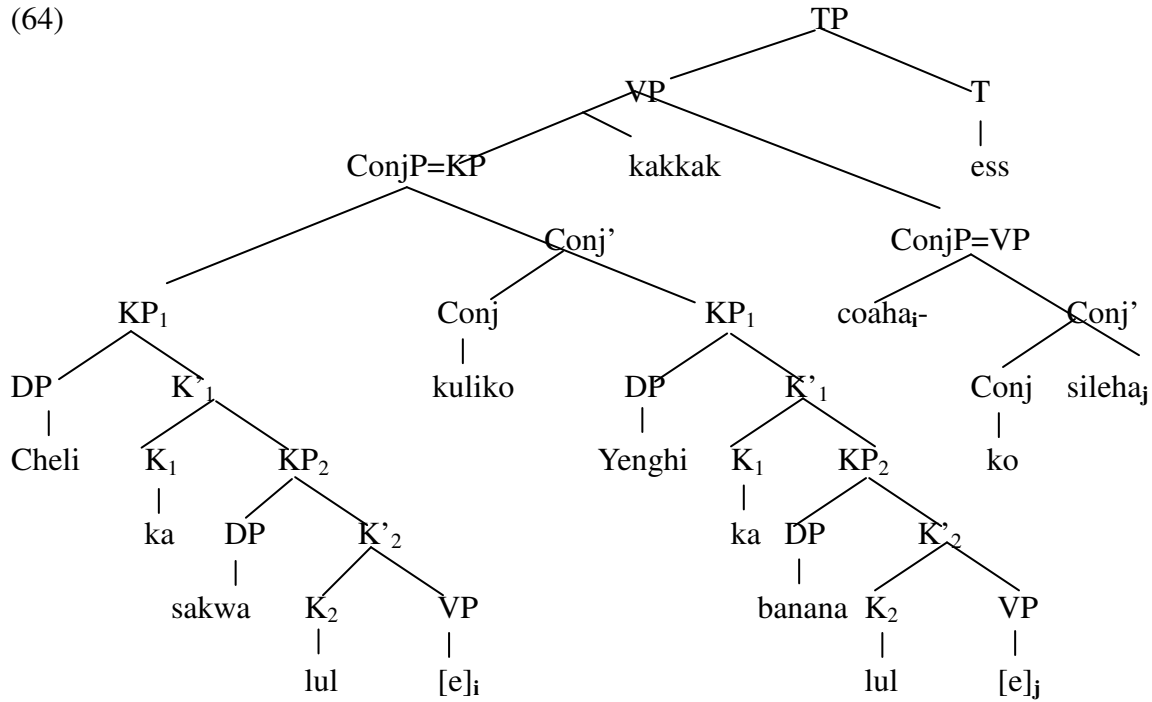

Likewise, both the first and the second conjunct license a null predicate [e] in (65) and start searching for an overt predicate to be unified. By the function of ‘respectively’, the null predicate in the initial conjunct is unified with the initial conjunct of the conjoined predicate ‘sakwa-lul coahata’ while the null predicate in the second conjunct, the second conjunct of the conjoined predicate ‘banana-lul silehata’ as illustrated in (65).

(65) Cheli-ka kuliko Yenghi-ka **kakkak**
 C-nom conj Y-nom respectively
 sakwa-lul coaha-ko banana-lul silhehay-ss-ta
 apple-acc like-conj banana-acc dislike-pst-decl
 ‘Cheli liked apples and Yenghi disliked bananas’

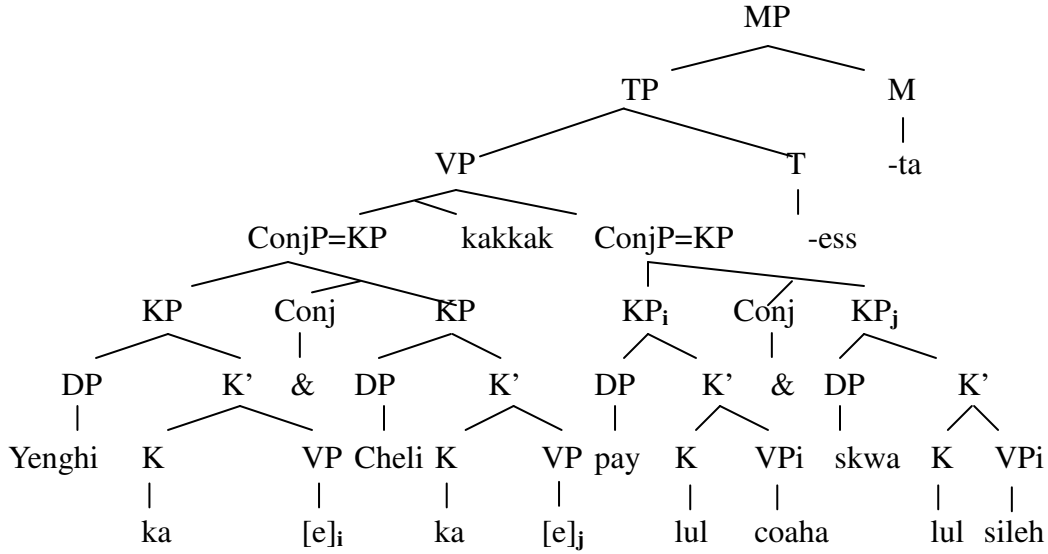

Other than this case, let us consider if the analysis accounts for CoRNR constructions with DPM as re-introduced in (66).

- (66) John-i piano-lul (kuliko) Mary-ka nolay-lul
 J-nom piano-acc conj M-nom song-acc
 yelsimhi-tul (kakkak) chi-ko pwulu-ess-ta
 hard-DPM respectively play-conj sing-pst-decl

‘John played the piano hard and Mary sang a song hard, respectively.’

As mentioned before, expressions which presuppose the existence of multiple entities *may not surface inside their licensing coordinate complexes*. (Carlson 1987) As Dummy Plural Mmarker *-tul* is among those expressions, it is positioned in an ATB position as illustrated in (67).

(67)

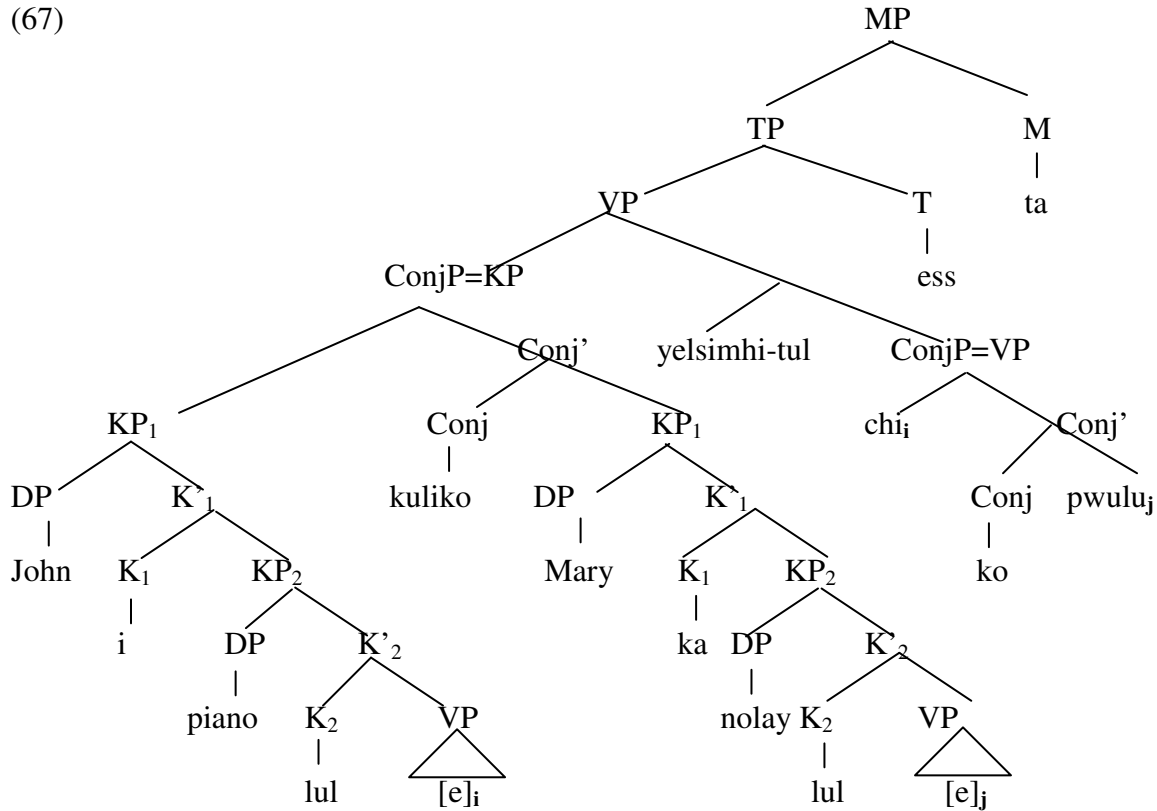

6. Conclusion/Implications

This research adds another type of construction (RNRs/CoRNRs) to those that have been analyzed in a similar vein – Case-marked NP Coordinations, Clefting and Fragments. One might ask why there should be so many different analyses as to the same construction ‘RNR’. However, just because a phenomenon recurs in different languages, it does not follow that they need be analyzed in the same way. As made clear by Huang 1984, different languages license null arguments in different ways. Baker (2001a) makes this point clearly for ‘non-configurationality’. Free word order can arise in different ways in different languages.

Also, it is notable that, despite an extensive criticism against movement approach of RNR, Sabbagh (2007) recently proposed a movement analysis for RNR in Tagalog, stating “with respect to at least one language, Tagalog, the classic analysis of RNR as ATB rightward

movement is correct” with arguments based on the extraction restriction. In this respect, at least in Korean and Japanese, RNR constructions are analyzed as involving a null predicate pro-form in the non-final conjunct.

Chapter 4:

Right Dislocation in Korean and Japanese

1. Introduction

In the chapters above, I discussed constructions involving null elements on the predicate side in Korean, which are represented by Type B coordinations, Right Node Raising constructions. This chapter examines right dislocation constructions in Korean and Japanese, which involve null arguments²¹ (in most cases) and null nominal/verbal predicates as we will see. Right dislocation constructions refer to constructions where a subject or an object, neither of which, in their canonical positions, occupies the rightmost position in verb-final languages like Korean and Japanese, is dislocated in the rightmost position of the sentence. As exemplified in (1-2), these constructions are composed of what I shall call the Host clause (the part before sentence ends such as Emp (Emphasis) in Japanese, Decl (Declarative) or Q (Interrogative) in Korean) followed by the Appendix in Sells' (1999) terms.

(1) a.	Ken-ga	kinoo	Chopin-o	hiita-yo
	Ken-nom	yesterday	Chopin-acc	played-Emph
b.	kinoo	Chopin-o	hiita-yo	Ken-ga
	yesterday	Chopin-acc	played-Emph	Ken-nom
c.	Ken-ga	Chopin-o	hiita-yo	kinoo
	Ken-nom	Chopin-acc	played-Emph	yesterday

²¹ Sometimes Right-Dislocations in Korean involve right-dislocation of modifiers (adjectives or adverbials), which we will discuss in the next section. Those instances do not involve null arguments, but still involve null nominal predicates as we will see.

d. Ken-ga	kinoo	hiita-yo	Chopin-o
Ken-nom	yesterday	played-Emph	Chopin-acc

‘Ken played Chopin yesterday.’ (Simon 1989 cited in Sells 1999)

(2) a. Cheli-ka	ecey	Yenghi-lul	manna-ss-ta
C-nom	yesterday	Y-acc	meet-pst-decl

b. ecey	Yenghi-lul	manna-ss-ta	Cheli-ka
yesterday	Y-acc	meet-pst-decl	C-nom

c. Cheli-ka	Yenghi-lul	manna-ss-ta	ecey
C-nom	Y-acc	meet-pst-decl	yesterday

d. Cheli-ka	ecey	manna-ss-ta	Yenghi-lul
C-nom	yesterday	meet-pst-decl	Y-acc

‘Cheli met Yenghi yesterday.’

Right-dislocation²² (RD henceforth), which is also called postposing and extraposition, is frequently found in colloquial speech in these languages. Appendices in RD examples are not just an afterthought (Simon 1989) and do not need to be in a separate intonation phrase (Sells 1999). Since the appendix is not merely an afterthought, I will investigate how they are derived (movement vs. base-generation) and get interpreted in relation to the host. I will offer an analysis consistent with proposals in the chapters above. Section 2 introduces various properties of RD constructions in Korean and Japanese. Section 3 presents a review of previous proposals and points out problems with them. Section 4, the main section of this chapter, proposes an alternative analysis of RD under the Incremental C-selectional Combinatoric Analysis (ICCA)

²² The term ‘Right-Dislocation’ does not imply that the construction involves movement.

proposed in this study. Specifically, a bi-clausal, base-generation analysis is proposed, where the second clause is proposed to be a composition of a fragment and a null predicate (verbal or a nominal). The Host and the appendix are proposed to form a discourse unit. Some generalizations and constraints on the generation or interpretation of the appendices follow. Section 5 concludes this chapter.

2. Various Properties of Right-Dislocation Constructions in Korean

Although the canonical word order in Korean and Japanese is SOV, any element that canonically precedes the predicate can sometimes be right-dislocated to follow the predicate. That is, as we have seen in (1-2), subjects and objects that usually appear before predicates can be postposed to the sentence-final position. This makes one suspect some simple rightward movement analyses for the dislocated elements. The situation, however, becomes complicated when considering right dislocations in sentences with embedded phrases/clauses (NP or CP), relative clauses or sentential subjects. Furthermore, things are different between RDs with a single appendix and those with multiple appendices. We first consider various RD constructions with a single appendix in the subsection immediately below.

2.1 Right Dislocations with a Single Appendix

Any element can occur as an appendix in a simple sentence as shown in (2) and repeated in (3) below.

(3) a.	Cheli-ka	ecey	Yenghi-lul	manna-ss-ta
	C-nom	yesterday	Y-acc	meet-pst-decl

b. ecey	Yenghi-lul	manna-ss-ta	Cheli-ka
yesterday	Y-acc	meet-pst-decl	C-nom
c. Cheli-ka	Yenghi-lul	manna-ss-ta	ecey
C-nom	Y-acc	meet-pst-decl	yesterday
d. Cheli-ka	ecey	manna-ss-ta	Yenghi-lul
C-nom	yesterday	meet-pst-decl	Y-acc

‘Cheli met Yenghi yesterday.’

In an RD construction, the gap can be realized as a full-fledged NP as in (4b) or as a pronoun as in (4c).

(4) a. Cheli-ka	_____	ilk-ess-ta	chayk-ul
C-nom	_____	read-pst-decl	book-acc
b. Cheli-ka	<i>chayk-ul</i>	ilk-ess-ta	<i>chayk-ul</i>
Cheli-nom	book-acc	read-pst-decl	book-acc
c. Cheli-ka	<i>kukes-ul</i>	ilk-ess-ta	<i>chayk-ul</i>
C-nom	it-acc	read-pst-decl	book-acc

‘Cheli read a book.’

Also, the host and the appendix can have a long distance relation, violating the Right Roof Constraint (RRC). That is, an element in the embedded clause can move long-distance out of its embedded clause to the sentence final position as in (5b).

- (5) a. Cheli-nun Yenghi-ka Tongswu-lul manna-ss-ta-ko malhay-ss-ta
 C-Top Y-nom T-acc meet-pst-decl-comp say-pst-decl
 ‘Cheli said that Yenghi met Tongswu’
- b. Cheli-nun Yenghi-ka manna-ss-ta-ko malhay-ss-ta Tongswu-lul
 C-Top Y-nom meet-pst-decl-comp say-pst-decl T-acc
 ‘Cheli said that Yenghi met Tongswu’

If we try to move the element, obeying RRC, the sentence will not be acceptable, as shown in (6). That is, the appendix is not allowed to occur between an embedded clause and a main clause as in (6b).

- (6)a. Cheli-nun Yenghi-ka Tongswu-lul manna-ss-ta-ko malhay-ss-ta
 C-Top Y-nom T-acc meet-pst-decl-comp say-pst-decl
 ‘Cheli said that Yenghi met Tongswu’
- b.*Cheli-nun Yenghi-ka manna-ss-ta-ko Tongswu-lul malhay-ss-ta
 C-Top Y-nom meet-pst-decl-comp T-acc say-pst-decl
 ‘Cheli said that Yenghi met Tongswu’

In addition to the RRC violation shown in (6), RD constructions show Island-like effects²³. Specifically, the acceptability of a sentence is significantly degraded when an element is right-dislocated from within a complex NP (an NP followed by a relative clause) as in (7a-b) or from within a sentential subject as in (7c). However, (7d) is totally unacceptable even though it does

²³ RD constructions with a pronominal or a full copy of the appendix in the host behave differently in terms of acceptability. This will be discussed later in section 4.

not violate any known constraints. That is, the locality observed in RDs is not identical to full movement locality in other constructions.

(7)a.?* Cheli-ka [Suni-ka ___ coaha-n-ta]-nun somwun-ul

C-nom S-nom like-pres-decl-Rel rumor-acc

tul-ess-ta, Tongswu-lul

hear-pst-decl T-acc

‘Cheli heard the rumor that Suni likes Tongswu.’

b. * Cheli-ka ___ manna-ss-ta-nun sasil-i motwu-lul nollakay hay-ss-ta

C-nom meet-pst-decl-Rel fact-nom everyone-acc surprise-pst-decl

Yenghi-lul

Y-acc

‘The fact that Cheli met Yenghi surprised everyone.’

c.*[[Nwukunka-ka ___ yel-un-kes]-i hwaksilha-ta]-ko

who-nom ___ open-rel-NM-nom be.certain-decl-comp

Yenghi-ka malhay-ss-ta, kumko-lul

Y-nom say-pst-decl safe-acc

‘Yenghi said, it is certain that someone opened the safe.’

d.*[Cheli-ka [(Sumi-ka) [Yenghi-ka _____ manna-ss-ta-ko]

Cheli-nom (Sumi-nom) Y-nom meet-pst-decl-comp

sayngkakhay-ss-ta-ko] malhay-ss-eyo] Tongswu-lul

think-pst-decl-comp say-pst-decl T-acc

When a wh-phrase is RD-ed as in (8), the original meaning is not preserved. Specifically, the sentence with a wh phrase in Korean is ambiguous between a wh-question and a yes/no question, as shown in (8a). However, when the wh-phrase is right-dislocated as in (8b), then only one of the meanings (yes/no question) survives, i.e., the yes/no question. As with other non-wh phrases, the gap can be overtly realized in the host clause as in (8c), but in this case, the sentence becomes ambiguous again, allowing both wh- and yes/no question readings. In this respect, wh-phrases behave differently than other phrases.

(8) a. Cheli-ka mwues-ul mek-ess-ni?

C-nom what-acc eat-pst-Q

‘What did Cheli eat?’

‘Did Cheli eat something?’

b. Cheli-ka mek-ess-ni, mwues-ul?

C-nom eat-pst-Q what-acc

^{ok} ‘Did Cheli eat something?’

*‘What did Cheli eat?’

c. Cheli-ka mwues-ul mek-ess-ni, mwues-ul?

C-nom what-acc eat-pst-Q what-acc

‘What did Cheli eat, what?’

‘Did Cheli eat something?’

So far we have considered cases where a case-marked NP is right-dislocated out of a VP, CP or MP. Not only case-marked NPs (that is, KPs), but relative clauses, adjectival phrases,

determiners and possessives can be RD-ed to be an Appendix²⁴. (9) shows RDs with relative clause appendices. When the whole relative clause ‘acwu caymi iss-nun’ is right-dislocated, the sentence is acceptable, but when the head noun ‘sosal-ul’ is right-dislocated, the host clause is not acceptable, rendering the sentence ungrammatical. That is, there is a clear contrast in acceptability between (9a) and (9b).

- (9) a. na-nun [____ sosal]-ul ilk-ess-e, acwu caymi iss-nun
 I-Top novel-acc read-pst-decl very interesting
 ‘I read a novel that is very interesting.’
- b. *na-nun [acwu caymi iss-nun ____] ilk-ess-e, sosal-ul
 I-Top very interesting read-pst-decl novel-acc

The examples in (10) show a right-dislocated possessor (10a) and a right-dislocated possessee (10b). When the possessor ‘Tongswu-uy’ is RD-ed, the sentence is fine, but when the head noun ‘cha-lul’ is right-dislocated, the sentence becomes unacceptable.

- (10)a. na-nun [_____ cha]-lul pilli-ess-e, Tongswu-uy
 I-Top car-acc borrow-pst-decl Tongswu’s

²⁴ Acceptability judgment on constructions with postposed modifiers varies in Korean unlike their counterparts in Japanese. Still, the constructions are observed especially in Korean soap operas, novels and essays. So we consider these examples as well. An excerpt from a Korean soap opera “the Queen of Housewives”:

- Q: Ne-nun kyelhon ani ha-ni?
 You-Top marriage Neg do-Q
 ‘Why don’t you get married?’
- A: Way anh hay? Na-to anay-ka philyha-y chakha-ko sallim cal ha-nun.
 Why Neg do? I-also wife-nom need-decl be.nice-conj house.work well do-REL
 ‘Why not? I too want to get married, to a nice woman who’s good around the house.’

‘I borrowed Tongswu’s car.’

b.* na-nun [Tongswu-uy _____] pilli-ess-e, cha-lul
I-Top Tongswu-Gen borrow-pst-decl car-acc

The examples in (11) show RDs with an adverbial appendix (11a) and an adjectival appendix (11b). When the adverb ‘acwu’ is postposed from the adjective phrase ‘acwu pissan’, the sentence is acceptable. However, when the head ‘pissa-n’ of the adjectival phrase is postposed, the host is unacceptable and so is the whole sentence.

(11)a. na-nun [___ pissan cha]-lul sa-ss-e, acwu/toykey
I-Top expensive car-acc buy-pst-decl very

‘I bought a very expensive car.’

b.* na-nun [acwu/toykey ___ cha]-lul sa-ss-e, pissan
I-Top very car-acc buy-pst-decl expensive

(12) is an RD that has a determiner in the appendix position. When the determiner ‘ilen’ is postposed, the sentence is acceptable. However, when the head noun ‘chayk-ul’ is postposed, the host is not acceptable, so the sentence is out.

(12)a. na-nun [___ chayk]-ul te sa-ya toy, ilen (conglyu-uy)
I-Top book-acc more buy-have.to this (kind of)

‘I have to buy this kind of book more.’

b.*na-nun [Ilen (conglyu-uy) ___] te sa-ya toy, chayk-ul
 I-Top this more buy-decl book-acc

Similar phenomena are observed in Japanese, too (Sells 1999). When a genitive-marked nominal is RD-ed as in (13a), the sentence is acceptable. On the other hand, when a head noun is RD-ed as in (13b), the sentence is out.

(13)a. Ken-wa [___ syasin-o] totta-yo Mari-no
 Ken-Top ___ photo-acc took-EMPH Mari-Gen
 ‘Ken took Mari’s photograph.’

b.*Ken-wa [Mari-no ___] totta-yo syasin-o
 Ken-TOP Mari-Gen ___ took-EMPH photo-acc

Similarly, when an adjectival phrase is RD-ed as in (14a), the sentence is acceptable. By contrast, when a head noun is RD-ed as in (14b), the sentence becomes unacceptable.

(14)a. Taroo-wa [___ zitensya-o] katta-yo hutuu-no
 T-nom ___ bicycle-acc bought-EMPH ordinary

b.* Taroo-wa [hutuu-no ___] katta-yo zitensya-o
 Taroo-nom ordinary ___ bought-EMPH bicycle-acc
 ‘Taroo bought an ordinary bicycle.’

Finally, when an initial conjunct of a coordinate structure is RD-ed as in (15a), the sentence is

acceptable. However, when the second conjunct is RD-ed as in (15b), the sentence becomes unacceptable.

(15)a. kodomo-wa [___ tiisai neko-o] hosigatteiru-no [ookii inu-to]
 child-Top ___ small cat-acc wants-EMPH big dog-CONJ
 ‘My child wants a big dog and a small cat.’

b.* kodomo-wa [ookii inu-to ___] hosigatteiru-no [tiisai neko-o]
 child-Top big dog-CONJ___ wants-EMPH small cat-acc
 ‘My child wants a big dog and a small cat.’ (Simon 1989)

All of these Korean and Japanese examples show that the RD constructions are acceptable as long as the host is well-formed²⁵ after an element has been dislocated to be an appendix.

In sum, if an RD construction is a simple sentence with a single appendix, it is acceptable as long as the host clause is well-formed and the appendix can get interpreted in the host clause.

In sentences with an embedded clause, the RRC is violated, but some Island/Subjacency-like effects are observed in the constructions.

²⁵ As we will see in 4.1, “sentence well-formedness” is defined when there is no incompatibility between the KPs and the verb in terms of verb classification. That is, the constraints that we impose on verbs is that they should be compatible with the preceding KP clusters in terms of case array and that verbs semantically, not syntactically, select the KPs, thus requiring semantic compatibility between KPs and the verb as well. Recall that, in the proposed system, verbs are classified into different valence classes and have all the semantic information on its own. Accordingly, even if some of the arguments are not present on the surface, as the predicates carry all the semantic information they need, the meanings of each sentence are delivered successfully. Thus, incompatibility results in ungrammaticality, while insaturation of verbs does not. As to other combinatoric markers such as adjectivalizers and relativisers, there were selectional constraints, which should be met to be a well-formed sentence. Specifically, both combinatoric markers takes a nominal to their right, so verbs cannot directly follow them.

All of these show that only a verb is an essential element to stand as a sentence in Korean, while in English all the arguments of a verb should be present to be a well-formed sentence. These interesting facts are well explained under the proposed system, where the verb semantically, not syntactically, selects the arguments and does not need to be saturated. In sum, just an argument or a series of arguments, with each case-marked, is an ellipsis construction with an empty verb syntactically, while a verb or a series of verbs is a perfect sentence with no empty slot structurally.

The appendix can be realized in the host clause as a full-fledged phrase or as a pronoun. In similar respects, the appendix can be followed by an overt predicate identical to/coindexed with the predicate in the Host. Wh-phrases behave differently than other phrases in the sense that it cannot be RD-ed without changing the original meaning of the sentence.

We will next consider examples with multiple appendices and examine what other conditions need to be met for RD constructions to be acceptable.

2.2 Multiple Appendices

Multiple appendices are possible in Korean as illustrated in (16a-d).

(16) Canonical Order:

Cheli-ka	kkoch-ul	Yenghi-eykey	cwu-ess-eyo
C-nom	flower-acc	Y-dat	give-pst-decl

‘Cheli gave flowers to Yenghi.’

Right-Dislocation:

a. Cheli-ka	cwu-ess-eyo	kkoch-ul	Yenghi-eykey
C-nom	give-pst-decl	flower-acc	Y-dat
b. Cheli-ka	cwu-ess-eyo	Yenghi-eykey	kkoch-ul
C-nom	give-pst-decl	Y-dat	flower-acc
c. cwu-ess-eyo	Cheli-ka	Yenghi-eykey	kkoch-ul
give-pst-decl	C-nom	Y-dat	flower-acc
d. cwu-ss-eyo	Yenghi-eykey	kkoch-ul	Cheli-ka
give-pst-decl	Y-dat	flowers-acc	C-nom

As discussed in Endo (1996), multiple appendices are allowed in Japanese as exemplified in (17a-b).

(17)a. Hon-o ageta-yo John-ga Mary-ni.

book-acc gave-Mod J-nom M-dat

‘He gave a book to her, John to Mary.’

b. Hon-o ageta-yo Mary-ni John-ga

book-acc gave-Mod M-dat J-nom

Multiple appendices are possible in sentences with embedded clauses as well. In multiple appendix constructions, the appendices have to be related to the same clause (Y-J Choi 2006) as we see in (18-19). (18) is acceptable because the RD-ed elements ‘Suni-eykey’ and ‘kkoch-ul’ are related to the same clause. (19) is not acceptable because the RD-ed elements ‘Dongswu-lul’ and ‘Suni-eykey’ are related to different clauses – the matrix clause and the embedded clause respectively.

(18) Cheli-ka [Yenghi-ka ____ ponay-ss-ta]-ko malhay-ss-eyo,

Cheli-nom Y-nom send-pst-decl-comp say-pst-decl

Suni-eykey kkoch-ul

S-dat flowers-acc

‘Cheli said that Yenghi sent Suni flowers.’

(19) *Cheli-ka ____ [Yenghi-ka ____ manna-ss-ta]-ko malhay-ss-eyo,

Cheli-nom Y-nom meet-pst-decl-comp say-pst-decl

Tongswu-lul Suni-eykey

T-acc S-dat

‘Cheli told Suni that Yenghi met Tongswu.’

In some cases, however, multiple appendices are possible even if they are related to different clauses. That is, example (19) can be acceptable depending on how it is parsed. Specifically, when (19) is parsed with a pause (marked with a slash) between the two appendices, it becomes acceptable as in (20), yielding a different interpretation than that of (19).

(20) Cheli-ka [Yenghi-ka ____ manna-ss-ta]-ko ____ malhay-ss-eyo

Cheli-nom Y-nom meet-pst-decl-comp say-pst-decl

Tongswu-lul / Suni-eykey

T-acc S-dat

‘Cheli told Suni that Yenghi met Tongswu.’

Example (21) makes a similar point. In particular, the first interpretation comes out when the two appendices are related to the same clause – the embedded one. The second interpretation is obtained when there is a pause between the two appendices, making the one appendix related to the matrix clause and the other connected to the embedded clause.

(21) Na-nun Cheli-ka cwu-ess-ta-ko malhay-ss-e

I-Top C-nom give-pst-decl-comp say-pst-decl

Suni-eykey ku panci-lul
 S-dat the ring-acc

- (i) ‘I said that Cheli gave Suni the ring.’
 (ii) ‘I told Suni that Cheli gave (me) the ring.’

Baker (2007) also reports that ‘NP-Mate’ Condition holds when multiple adnominal constituents are RD-ed as in (22a-b). Just two adnominals can be RD-ed, but in this case, something like phrase-mate condition is observed, hence the term NP-Mate Condition. Specifically, (22a) is acceptable because the two RD-ed adnominals are related to the same NP. (22b), however, is not acceptable because the two RD-ed adnominals are related to two different NPs.

- (22)a. Ne [___i ___j ku cha]-lul po-ass-ni?
 You the car-acc see-pst-Q
 [Hyundai-ka mantu-n]_i [ipen-ey saylo nao-n]_j?
 H-nom make-rel this.time newly be.launched-rel
 ‘Did you see that Hyundai car that was newly released?’
- b. *[___i sonnim]-i [___j neykthai]-lul manhi sa-ss-e,
 guest-nom neck.tie-acc many buy-pst-decl
 [ton-i manha poi-nun]_i [phurangsu-eyse swuipha-n]_j
 money-nom plenty seem-rel France-from import-rel
 ‘A customer who looks rich bought a lot of ties imported from France.’

Exactly the same is observed with adverbials as exemplified in (23-24). Two adverbials related to

the same clauses can be right-dislocated as in (23), while those related to two different clauses cannot as in (24).

(23) Adverbials related to the same clause:

a. Yenghi-ka Cheli-ka ecey twu sikan-ina cikakhay-ss-ta-ko
 Y-nom C-nom yesterday two hours.as.much.as be.late-pst-decl-comp
 pokoha-lke-ya
 report-fut.conjec-decl

‘Yenghi will report that yesterday Cheli was late as much as two hours.’

b.^{ok} Yenghi-ka Cheli-ka cikakhay-ss-ta-ko pokoha-lke-ya
 Y-nom C-nom be.late-pst-decl-comp report-fut.conjec-decl
 ecey twu sikan-ina
 yesterday two hours.as.much.as

‘Yenghi will report that yesterday Cheli was late as much as two hours.’

(24) Adverbials related to two different clauses:

a. Yenghi-ka Cheli-ka twu sikan-ina cikakhay-ss-ta-ko
 Y-nom C-nom two hours.as.much.as be.late-pst-decl-comp
 nayil pokoha-lke-ya
 Tomorrow report-fut.conjec-decl

‘Tomorrow Yenghi will report that Cheli will be late as much as two hours.’

b.* Yenghi-ka Cheli-ka cikakhay-ss-ta-ko pokoha-lke-ya
 Y-nom C-nom be.late-pst-decl-comp report-fut.conjec-decl

nayil twu sikan-ina

Tomorrow two hours.as.much.as

‘Tomorrow Yenghi will report that Cheli will be late as much as two hours.’

Finally, there are sentences derived by RD iteration as in (25-26), which apparently look like a RD with multiple appendices. However, close examination reveals that they are not. Rather, they are constructions derived by an iterated application of RD process. Let us assume that RDs with multiple appendices are composed of [Host], [appendix 1], [appendix 2] ... [appendix N]. In (25), the appendix 1 is related to the host clause, and the appendix 2 is related to appendix 1 clause. Thus, this is an example of repeated applications of RD. Similarly, in (26), the appendix 1 is related to the host clause, and the appendix 2 is related to the appendix 1 clause. Thus, these are derived by RD iteration.

(25)Na-nun sayngkakha-n-ta, Cheli-ka manna-ss-ta-ko, Tongswu-lul

I-Top think-pres-decl C-nom meet-pst-decl-comp T-acc

‘I think Cheli met Tongswu.’

(26)Na-nun sayngkakha-n-ta, Cheli-ka Tongswu-lul manna-ss-ta-ko,

I-Top think-pres-decl C-nom T-acc meet-pst-decl-comp

ecey

Yesterday

‘I think Cheli met Tongswu yesterday.’

Before going to the next section, the discussion so far can be summarized as Table 1, which

shows the crucial properties of RD constructions that need be accounted for.

Table 2. Properties of Right-Dislocation in Korean and Japanese

<i>Properties of Right-Dislocations in J/K</i>	<i>Examples</i>
Allowing Pronoun or Full Copy in the host	(4)
RRC violation	(5-6)
Subjacency-like effects	(7a-d)
Different behaviors of WH-phrase as an appendix	(8a-c)
? Clause-mate condition with multiple appendices	(18-24)
RD Iteration	(25-26)

3. Previous Proposals

As we have seen in section 2, RD constructions have various interesting properties, and several analyses have been proposed. The analyses are largely based on the following categorizations -- monoclausal vs. biclausal; movement vs. base-generation; rightward movement vs. leftward movement. Among them are monoclausal, rightward movement analyses (Haraguchi 1973; Murayama 1999; Simon 1989; H-S Choe 1986 for movement analysis of Korean), bi-clausal analysis²⁶ with (leftward) scrambling in the second clause followed by deletion (Abe 1999; Kuno 1978; Takita 2008; Tanaka 2001). On the other hand, base-generation analysis²⁷ has been proposed by Sells (1999) for Japanese and Y-J Choi (2006) for Korean. We will discuss these

²⁶ Though the same in the sense that all these are bi-clausal, Kuno (1978)'s analysis is different from Tanaka (2001)'s in that it does not involve leftward movement in the second clause. Takita (2008)'s analysis is also different from Tanaka's in the sense that the gap in the first clause is not *pro*, but undergoes argument ellipsis, based on the observation of the behavior of NPI/quantifier with respect to RD in Japanese.

²⁷ Sells (1999) proposes a monoclausal analysis, while Choi (2008) a biclausal analysis.

representative proposals, pointing out problems with each analysis.

3.1 Right Movement + Monoclausal Analysis (Haraguchi 1973; Murayama 1999; Simon 1989)

Rightward movement analysis proposes that an RDed element is simply moved out of the sentence and subsequently adjoined to the sentence final position as depicted in (27).

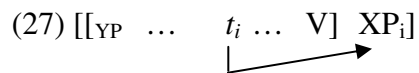

This analysis naturally accounts for the existence of a gap in the host and the subjacency-like effects as it moves an element out of the Host to the sentence final position. Though this analysis accounts for examples where a single KP is postposed, it has difficulties accounting for examples where the appendix is a relative clause, a possessor or a determiner as in (28-30), which cannot be accounted for in this analysis.

(28) na-nun [___ sosel]-ul ilk-ess-e, acwu caymi iss-nun
 I-Top novel-acc read-pst-decl very interesting
 ‘I read a novel that is very interesting.’

(29) na-nun [_____ cha]-lul pilli-ess-e, Tongswu-uy
 I-Top car-acc borrow-pst-decl Tongswu’s
 ‘I borrowed Tongswu’s car.’

(30) na-nun [___ chayk]-ul te sa-ya toy, ilen (conglyu-uy)
 I-Top book-acc more buy-have.to this (kind of)

‘I have to buy this kind of book more.’

In similar respects, this analysis cannot explain why the interpretation of (31b) is not the same as (31a) if (31a) is the source of (31b).

(31)a. Cheli-ka mwues-ul mek-ess-ni?

C-nom what-acc eat-pst-Q

‘What did Cheli eat?’

‘Did Cheli eat something?’

b. Cheli-ka mek-ess-ni, mwues-ul?

C-nom eat-pst-Q what-acc

^{ok} ‘Did Cheli eat something?’

*‘What did Cheli eat?’

Finally, this analysis cannot explain why the locality observed in RDs is not identical to full movement locality in other constructions.

3.2 Bi-clausal analysis with scrambling followed by deletion under identity (Abe 1999; Tanaka 2001; Yamashita 2008)

Due to the problems with the movement analysis discussed above, an alternative analysis has been proposed by Tanaka (2001) among others, which suggests that the RD constructions are actually composed of two clauses and that the appendix is scrambled out of the second clause, which subsequently undergoes deletion under identity with the initial clause as illustrated in (32).

(32) Abe 1999; Tanaka 2001; Yamashita 2008

[_{YP} ... *pro*_i ... V], [_{XP_i} [_{YP} ... *t_i* ... V]]

As depicted in (32) above, there is no trace in this analysis as it undergoes deletion in the second clause. So, this works well with the facts associated with resumption and overt copies in the host clause. Also, as evidence for scrambling in the second clause, Tanaka presents a number of empirical arguments based on reciprocal binding, adverbials, wh-questions etc., showing some similarities between RD constructions and scrambling. That is, when scrambling is not possible, RD constructions with a scrambled appendix are also unacceptable.

Now, let us take a look at how this analysis accounts for a simple RD in (33). The derivation is as illustrated in (34). First, two identical clauses are constructed, in which the initial conjunct contains a *pro* as shown in (34a). The would-be appendix undergoes scrambling as in (34b). The second clause undergoes deletion under identity as in (34c), yielding the final RD construction.

(33)a. Cheli-ka chayk-ul ilk-ess-ta.

Cheli-nom book-acc read-pst-decl

b. Cheli-ka ilk-ess-ta, chayk-ul

Cheli-nom read-pst-decl book-acc

‘Cheli read a book’

(34) a. *Construction of two clauses with a pro in the initial clause*

[Cheli-ka pro ilk-ess-ta] [Cheli-ka chayk-ul ilk-ess-ta]

b. *Scrambling in the second clause*

[Cheli-ka pro ilk-ess-ta] [chayk-ul_i [Cheli-ka t_i ilk-ess-ta]]

c. *Deletion under identity*

[Cheli-ka pro ilk-ess-ta] [chayk-ul_i [~~Cheli-ka~~—~~t_i~~—ilk-ess-ta]]

As shown in (34), there is no syntactic movement relation between the gap (*pro*) in the first clause and the right-dislocated phrase in the second clause. So, no gap is needed in the first clause and *pro* can be realized as the identical lexical item or as a pronoun as in (35).

(35)a. Cheli-ka chayk-ul ilk-ess-ta, chayk-ul

Cheli-nom book-acc read-pst-decl book-acc

b. Cheli-ka kukes-ul ilk-ess-ta, chayk-ul

Cheli-nom it-acc read-pst-decl book-acc

‘Cheli read a book’

As this analysis involves leftward movement, it predicts the RD-ed element is subject to subjacency. Since scrambling is constrained by the subjacency condition (Harada 1977, Saito 1985), it is expected that RD is constrained by subjacency²⁸ as in (36).

(36) ?* Cheli-ka [Suni-ka coaha-n-ta]-nun somwun-ul tul-ess-eyo,

C-nom S-nom like-pres-decl-Rel rumor-acc hear-pst-decl

Tongswu-lul

T-acc

‘I heard the rumor that Suni likes Tongswu.’

²⁸ As it will turn out, RD constructions are not subject to subjacency, but just show some subjacency-like effects.

The analysis correctly predicts that (37) is acceptable, while (39) is not. Specifically, (37) is derived as in (38), where the pre-deletion appendix clause is acceptable because the scrambled elements are related to the same clause. On the other hand, (39) is derived as in (40), where the pre-deletion appendix clause is not acceptable because the scrambled elements are not related to the same clause. That is, it violates the clause-mate condition on multiple scrambling (Y-J Choi 2008).

(37) Cheli-ka [Yenghi-ka ____ ponay-ss-ta]-ko malhay-ss-eyo,
 Cheli-nom Y-nom send-pst-decl-comp say-pst-decl
 Suni-eykey kkoch-ul
 S-dat flowers-acc
 ‘Cheli said Yenghi sent Suni flowers.’

(38) Cheli-ka [Yenghi-ka *pro_i* *pro_j* ponay-ss-ta]-ko malhay-ss-eyo,
 Suni-eykey_i kkoch-ul_j [~~Cheli-ka [Yenghi-ka *t_i* *t_j* ponay-ss-ta]-ko~~
~~malhay-ss-eyo]~~

(39) *Cheli-ka ____ [Yenghi-ka ____ manna-ss-ta]-ko malhay-ss-eyo,
 Cheli-nom Y-nom meet-pst-decl-comp say-pst-decl
 Tongswu-lul Suni-eykey
 T-acc S-dat
 ‘Cheli told Suni that Yenghi met Tongswu.’

(40) *Cheli-ka [Yenghi-ka *pro_i* manna-ss-ta]-ko *pro_j* malhay-ss-eyo,
 Tongswu-lul_i Suni-eykey_j [~~Cheli-ka [Yenghi-ka *t_i* manna-ss-ta]-ko *t_j*~~
~~malhay-ss-eyo]~~

Let us now consider RD iteration cases as in (41b). We will see if Tanaka’s analysis correctly predicts this to be well-formed. Tanaka (2001) recognizes the difficulty and proposes a three-clause analysis as in (42).

(41)a. Na-nun Cheli-ka Tongswu-lul manna-ss-ta-ko sayngkakha-n-ta
 I-Top C-nom T-acc meet-pst-decl-comp think-pres-decl
 ‘I think that Cheli met Tongswu’

b. Na-nun sayngkakha-n-ta/ Cheli-ka manna-ss-ta-ko/ Tongswu-lul
 I-Top think-pres-decl C-nom meet-pst-decl-comp T-acc
 ‘I think that Cheli met Tongswu’

Tanaka’s analysis derives (41b) as follows.

(42) Na-nun sayngkakha-n-ta/ Cheli-ka manna-ss-ta-ko/ Tongswu-lul

→ [Na-nun pro_i sayngkakha-n-ta],

[[Cheli-ka pro_j manna-ss-ta-ko]_i ~~Na-nun t_j sayngkakha-n-ta~~]

Tongswu-lul_j ~~Na-nun [Cheli-ka t_j manna-ss-ta-ko] sayngkakha-n-ta~~

As discussed above, *pro* in the initial clause can be overtly realized as a full-fledged phrase. Therefore, this analysis incorrectly predicts that (43) has the same interpretation as (44). However, while (43) is ambiguous, the ambiguity disappears when the *wh*-phrase is RDed as in (44).

(43)ne-nun mwues-ul mek-ess-ni, mwues-ul?

You-Top what-acc eat-pst-Q what-acc

‘What did you eat?’

‘Did you eat something?’

(44)ne-nun mek-ess-ni, mwues-ul?

You-Top eat-pst-Q what-acc

‘Did you eat something?’

However, Tanaka (2001) avoids this problem by saying that the sentence in (44) is ruled out for an independent reason, namely that since a wh-phrase in a question is inherently focus-bearing new information (Kuno 1978), it cannot be right-dislocated leaving a gap (*pro*) in the initial clause. For this reason, Tanaka suggests we consider gapless RD cases as in (45-46) when the appendix is wh-phrase.

(45)Cheli-ka Mary-ka mwues-ul mek-ess-ta-ko malhay-ss-ni, mwues-ul?

C-nom M-nom what-acc eat-pst-decl-comp tell-pst-Q what-acc

‘What did Cheli say Mary ate, what?’

→ Semantic compatibility

(46)* Cheli-ka Mary-ka mwues-ul mek-ess-ta-ko kiekha-ko iss-ni,

C-nom M-nom what-acc eat-pst-decl-comp remember-comp prog.Q

mwues-ul?

What-acc

‘Does John remember what Mary ate, what?’

→ Semantic incompatibility

(45) is acceptable because the host clause and the appendix clause are semantically compatible. However, (46) is not since the two clauses are not semantically compatible. Specifically, his analysis predicts that (45), before the second clause undergoes deletion, is composed of two clauses – ‘Cheli-ka Mary-ka mwues-ul mek-ess-ta-ko malhay-ss-ni?’ and ‘mwues-ul Cheli-ka Mary-ka mek-ess-ta-ko malhay-ss-ni?’, which have the same interpretation ‘What did Cheli say Mary ate?’. So, the second clause can undergo deletion without problems. On the other hand, (46), before the second clause undergoes deletion, is made up of two clauses – ‘Cheli-ka Mary-ka mwues-ul mek-ess-ta-ko kiekha-ko iss-ni?’ and ‘mwues-ul Cheli-ka Mary-ka mek-ess-ta-ko kiekha-ko iss-ni?’, which have the interpretation ‘What does Cheli remember Mary ate?’ and ‘As to what, does Cheli remember that Mary ate it?’ respectively, both being semantically incompatible. In this way, Tanaka avoids making an incorrect prediction regarding RDs with a *wh*-phrase as an appendix.

Finally, as indicated by Takita (2001), this analysis has a problem accounting for examples including NPIs as illustrated in (47). (See subsection 3.3. for a detailed argument for this.) Specifically, Tanaka’s (2008) analysis predicts an overt pronoun *sore-o* can fill in the gap in (47) as the position is *pro* in his analysis.

- (47) Taroo-ga { ^{ok}LGB-**sika**/*sore-o }_i yom-**anak**-atta-yo, LGB-**sika**_i
 T-nom LGB-only/it-acc read-neg-pst-prt LGB-only
 ‘Taroo read only LGB/it_i, only LGB_i’

We have seen both advantages and disadvantages of Tanaka (2001). In the next subsection, we will consider Argument Ellipsis analysis that solves some of Tanaka’s problems regarding NPIs or Quantifiers as an appendix.

3.3 Argument Ellipsis Analysis (Takita 2008)

Takita (2008) basically adopts Tanaka (2001)’s bi-clausal analysis with some modification where the gaps in the Host clause in Japanese Right Dislocation are created via Argument Ellipsis (Oku 1998, Kim 1999, Saito 2004) instead of being instances of *pro*. He proposes (48) based on the observation that even NPIs and Quantifiers can be subject to Argument Ellipsis, showing that previous approaches fail to capture the behavior of Japanese Right-Dislocation with NPIs and quantifiers as an appendix.

(48) a. *Underlying structure*

[Clause1 ... NPI/quantifier ... V], [Clause2 ... NPI/quantifier ... V]

b. *Argument Ellipsis in the first clause*

[Clause1 ... ~~NPI/quantifier~~ ... V], [Clause2 ... NPI/quantifier ... V]

c. *Leftward movement followed by deletion in the second clause*

[Clause1 ... NPI/quantifier ... V], [Clause2 NPI/quantifier_i [~~... ..#~~ V]]

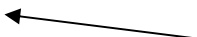

Now let us consider example (47) again, repeated in (49). The gap can be overtly realized as a full-fledged phrase *LGB-o* or as a pronoun *sore-o* ‘it’, which is predicted under Tanaka’s “clause repetition + deletion” approach since Tanaka’s analysis posits *pro* in the initial clause and *pro* can be replaced by the pronoun or the full-fledged phrase.

- (49) Taroo-ga { LGB-o/sore-o/e}_i yonda-yo, LGB-o_i
 T-nom LGB-acc/it-acc read-Prt LGB-acc
 ‘(lit.) Taroo read LGB/it/*e_i*, LGB_{*i*}’

However, Takita (2008) shows that Tanaka’s analysis faces a problem under close examination. Before we see the problem, let us first look at the behavior of the NPI ‘sika’ in Japanese. In Japanese, a phrase turns into an NPI if the suffix *sika* ‘only’ is attached to it, and as an NPI, it requires negation to appear as in (50a-b).

- (50)a. Taroo-ga LGB-o yonda
 T-nom LGB-acc read
 ‘Taroo read LGB’
 b. Taroo-ga LGB-**sika** { * yonda/^{ok} yom-**anak**-atta }
 T-nom LGB-only read/read-neg-Pst
 ‘Taroo read only LGB.’

As we see in (51), the NPI ‘sika’ can appear as an appendix in RD constructions when negation is present in the host clause (cf. Kuno 1978, Murayama 1999).

- (51) Taroo-ga *e_i* { *yonda-yo/^{ok} yom-**anak**-atta-yo }, LGB-**sika**_{*i*}
 T-nom read-Prt/read-Neg-Pst-Prt LGB-only
 ‘Taroo read *e_i*, only LGB_{*i*}’

Here, unlike other arguments, the gap cannot be realized as a pronoun when an NPI occurs as an appendix in an RD, while a full-fledged NPI can, as we see in (52).

- (52) Taroo-ga {^{ok} LGB-**sika**/*sore-o}_i yom-**anak**-atta-yo, LGB-**sika**_i
 T-nom LGB-only/it-acc read-neg-pst-prt LGB-only
 ‘Taroo read only LGB/it_i, only LGB_i’

A similar phenomenon is found with a quantifier like *nanika* ‘something’ as in (53). That is, the gap can be realized as a full-fledged expression, but not as a pronoun.

- (53) Taroo-ga {^{ok} **nanika-o**/*sore-o/e}_i yonda-yo, **nanika-o**_i
 T-nom something-acc/it-acc read-Prt something-acc
 ‘Taroo read something/it/e_i, something_i’

Based on the observation so far, Takita proposed Argument Ellipsis analysis to account for the constructions with an NPI or a quantifier. For example, (52) is derived as in (54). This analysis is basically the same as Tanaka (2001)’s except that the gap in the initial clause is not *pro* and can be optionally realized overtly as a full-fledged noun, but not as a pronoun in the host clause.

(54)a. *Underlying Structure*

[T-ga LGB-**sika** yom-**anak**-atta-yo] [T-ga LGB-**sika** yom-**anak**-atta-yo]

b. *Argument Ellipsis in the first clause*

[T-ga ~~LGB-**sika**~~ yom-**anak**-atta-yo] [T-ga LGB-**sika** yom-**anak**-atta-yo]

c. *Leftward movement followed by deletion in the second clause*

[T-ga ~~LGB-sika_i~~ yom-**anak**-atta-yo] [LGB-**sika** [T-ga-t_i yom-~~anak~~-atta-yø]]

The same facts are observed in Korean as well. NPIs like ‘amwuto’ and ‘amwukesto’ in Korean require negation in the same clause they appear in. The NPI ‘amwukesto’ can be RDED and it requires the negation ‘anh’ to appear in the host clause as in (55a-b) and the NPI can be overtly realized in the host clause without any semantic change as in (56a-b).

(55)a. na-nun ilk-ci anh-ass-e amwukesto
 I-Top read-Neg-Pst-decl anything
 ‘I did not read anything.’

b. Na-nun manna-ci anh-ass-e amwuto
 I-Top meet-NEG-Pst-decl anyone
 ‘I did not meet anyone.’

(56)a. na-nun amwukesto ilk-ci anh-ass-e amwukesto
 I-Top anything read-Neg-Pst-decl anything
 ‘I did not read anything.’

b. Na-nun amwuto manna-ci anh-ass-e amwuto
 I-Top anyone meet-NEG-Pst-decl anyone
 ‘I did not meet anyone.’

The gap, however, cannot be filled with an overt pronoun ‘ku-kes’ or ‘ku’ as we see in (57a-b).

(57)a.* na-nun kukes-ul ilk-ci anh-ass-ta, amwukesto
 I-Top it-acc read-Neg-Pst-decl anything

‘I did not read it, anything.’

b.* Na-nun ku-lul manna-ci anh-ass-ta, amwuto
 I-Top he-acc meet-NEG-Pst-decl anyone

‘I did not meet him, anyone.’

Similar accounts can be made for RD constructions with quantifiers. The quantifier in (58a) can be overtly realized as a full-fledged noun in the host as in (58b), but not as a pronoun as in (58c).

(58)a. na-nun ilk-ess-ta, mwuesinka-lul
 I-Top read-pst-decl something-acc

‘I read something.’

b. na-nun mwuesinka-lul ilk-ess-ta, mwuesinka-lul
 I-Top something-acc read-pst-decl something-acc

‘I read something.’

c.* na-nun kukes-lul ilk-ess-ta, mwuesinka-lul
 I-Top it-acc read-pst-decl something-acc

‘I read it, something.’

Though Takita’s analysis is plausible in accounting for some novel examples with NPI and some quantifiers, his analysis faces exactly the same problems as Tanaka’s because both analyses are the same except on the property of the gap in the initial clause.

3.4 Base-Generation Analyses (Sells 1999, Y-J Choi 2005)

3.4.1 Sells 1999

Unlike previous movement approaches, Sells (1999) proposed a base-generation analysis where an appendix is base-generated and adjoined to the host. As long as the host is well-formed, obeying the morphosyntactic constraint, and as long as the appendix can find its original position using the cue of combinatoric markers, the RD constructions in question should be grammatical. Adopting the framework of lexical-functional grammar (LFG; Bresnan 1982, 1999), Sells presents Japanese combinatoric functional specifications as in (59), where for any non-head β ,

- (59) a. If β = case or Topic marked N', Adverbial P', then CAT (GF \uparrow), V).
b. If β = Determiner, Adjective, Relative clause, Genitive modifier, then CAT (GF \uparrow), N).
c. If β = X-to, then $\downarrow \in$ (GF \uparrow).

Based on the cues presented above, for example, in (60), the case-marked N' 'Yenghi-lul', according to (59a), finds V in the Host and is interpreted.

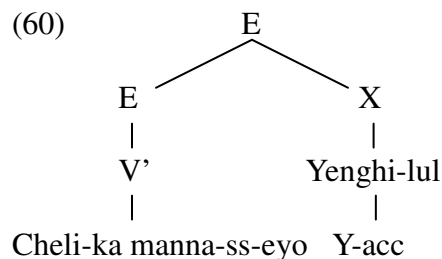

In addition, as this proposal does not assume “movement”, it can account for examples with the right-dislocated determiner, relative clause or possessor as an appendix, which movement

approach fails to explain. Specifically, the specification in (59c) helps right-dislocated determiners, relative clauses and possessors find their interpretive places in the Hosts without the movement assumptions.

However, RD constructions with filled gap positions are difficult to explain, given the completeness and coherence constrains (i.e., the Theta Criterion) of LFG. Let us consider examples (61-62).

(61) Yenghi-ka ku-lul manna-ss-ta Cheli-lul

Y-nom he-acc meet-pst-decl C-acc

‘Yenghi met him, Cheli.’

(62) Cheli-ka amukesto mek-ci anh-ass-ta amwukes-to

C-nom anything eat-NEG-pst-decl anything

‘Cheli did not eat anything --- anything.’

In the above examples (61-62), the gap position in the Host is filled in by overt nouns. That is, the Host clauses’s GF’s are saturated, so that there is no room for the appendix to be integrated into the f-structure of the Host clause.

3.4.2 Y-J Choi (2006)

Y-J Choi (2006) proposed a bi-clausal, base-generation analysis where an appendix licenses a null predicate and comprises a clause. This null predicate is assumed to be bound by the overt predicate in the host clause. Specifically, the appendix clause is adjoined to the host as in (63), which, she claims, allows multiple appendices and explains the subjacency effects in RD

constructions.

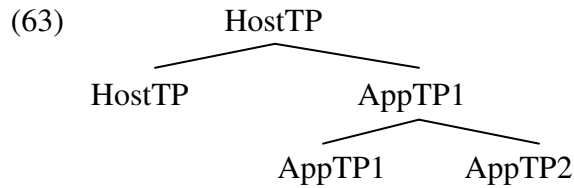

Choi claims, this adjunction structure provides an appropriate constraint for null predicate binding. For example, binding of the predicate is possible when it crosses CP (long distance dependency), but it is not possible when it crosses NPs (CNPC and CED). However, the locality condition is not strictly applied in these constructions.

As to multiple appendix RDs, she proposed a “clause-mate condition”, namely that the appendices should be related to the same clause. Specifically, as to (64-65), she argues that (64) is out because the appendices are related to different clauses, while (65) is acceptable because the appendices are related to the same clause.

(64) *Cheli-ka ___ [Yenghi-ka ___ manna-ss-ta]-ko malhay-ss-eyo
 Cheli-nom Y-nom meet-pst-decl-comp say-pst-decl
 Suni-eykey Tongswu-lul
 S-dat T-acc
 ‘Cheli told Suni that Yenghi met Tongswu.’

(65) Cheli-ka [Yenghi-ka ___ ponay-ss-ta]-ko malhay-ss-eyo,
 Cheli-nom Y-nom send-pst-decl-comp say-pst-decl

Suni-eykey kkoch-ul
 S-dat flowers-acc

However, as pointed out earlier, example (64) can be acceptable depending on how it is parsed. That is, when it is uttered with a pause, it becomes acceptable, obtaining the relevant interpretation ‘Cheli said to Suni that Yenghi met Tongswu’. Let us consider one more example (66), where the clause-mate condition can be loosened. According to Choi’s clause-mate condition, (66) should always mean ‘I said that Cheli gave Suni the ring’ because she bans the interpretation where the appendices are related to different clauses. This is not the case; it can mean ‘I said to Suni that Cheli gave the ring (to me)’ by speaking or reading with a pause between the two case marked NPs (KPs). It is not necessary that the KP clusters combine together and select one predicate.

(66)Na-nun Cheli-ka cwu-ess-ta-ko malhay-ss-e
 I-Top C-nom give-pst-decl-comp say-pst-decl
 Suni-eykey ku panci-lul
 S-dat the ring-acc

- ‘I said that Cheli gave Suni the ring.’
- ‘I told Suni that Cheli gave (me) the ring.’

In addition, as will be discussed in detail in 4.5, the locality detected in the RD constructions is not the same as the full movement locality such as CNPC and CED.

4. The Proposal

In this section, I will propose an alternative analysis of RD constructions under the Incremental C-selectional Combinatoric Analysis (ICCA). Specifically, I propose that RD constructions are composed of two independent clauses -- the host clause and the appendix clause. Specifically, when the appendix is just a case-marked NP, it is proposed that the case-marked NP comprises an independent, base-generated clause, in which the appendix is followed by a null verbal predicate [e].

Likewise, when the appendix is a relative clause or one of the other NP modifiers, it is proposed to be a separate, base-generated clause in which the appendix is followed by a null nominal predicate [e]. The Host and the Appendix clause are not connected by adjunction, so neither of the two clauses is positioned higher than the other for predicate binding. They are just loosely related to each other in the sense that RD constructions are acceptable as long as the Host clause is well-formed²⁹ and the null verbal/nominal predicate [e] (locally) licensed by the appendix finds a compatible overt predicate/noun in the Host to be co-indexed with it and get interpreted. Under ICCA, as discussed in Chapter 2, the contents of the null predicate are resolved cataphorically within a sentence because Korean and Japanese are verb-final languages. However, when the contents of the null predicate must be recovered outside of a clause as in the null predicate of an appendix of an RD, they are resolved anaphorically³⁰. So, the rough structure would be as follows (67).

²⁹ This follows the definition of the well-formedness indicated previously in footnote 5. (See 4.1 for more detailed discussion.)

³⁰ The other construction where the null predicate is resolved anaphorically is Fragments, where the contents of elliptical part depends on the linguistic antecedent as example (i) shows:

- (i) Q: Ne-nun nukwu-lul manna-ss-ni?
 You-Top who-acc meet-pst-Q
 ‘Who did you meet?’
A: Cheli-lul.
 Cheli-acc.
 ‘(I met) Cheli.’

(67)[_{HC} Host] [_{AC} Appendix [e]]

HC: Host Clause, AC: Appendix Clause/Part

Crucially, as we will discuss in the next subsection (4.1), under ICCA, even when a sentence is composed of a subject and a (di)transitive verb only or when a sentence is missing a subject, they are still acceptable, and we do not need to posit an empty slot (trace or *pro*) for the gap in the structure. As with argument ellipsis constructions, the host clause containing some gaps is acceptable as long as there is no incompatibility between the KP clusters and the predicate.

After discussing the structure of null argument constructions briefly in 4.1, we will also consider the structure of the appendix part in 4.2 because the Host, in most cases, contains some (argumental) gaps. We will then move on to consider how each of the examples above can be accounted for and what constraints should be imposed in relation to interpretation under the proposed analysis.

4.1 The Host

In order to posit a correct structure for the Host, let us first consider, under the ICCA, what kind of structure should be imposed on the constructions with missing arguments. Before starting the discussion, let me briefly mention that not all Host clauses lack (one of their) arguments. In some cases, especially the cases where the RDed element is an adjunct (adverbials or adnominals), the Host does not contain any (semantic) gaps. As only the sentences with argumental gaps are controversial when proposing structures, I will consider those examples only. Recall from Chapter 2 that under ICCA, MP is a well-formed, complete sentence and verbs do not need to be saturated, i.e., verbs do not need to discharge all their theta roles to overt arguments or *pro*'s,

since, in this system, predicates are not functors requiring their arguments syntactically. The constraints that we impose on verbs are that (i) verbs should be compatible with the preceding KP clusters in terms of case array and verb classification (See (68) below for verb classification) and (ii) verbs semantically, not syntactically, select the KPs, hence requiring semantic compatibility between KPs and the verb. Thus, incompatibility results in ungrammaticality, while an undischarged theta value that a verb possesses does not. (This is impossible in English due to the presence of uninterpretable (purely syntactic, formal) features on predicative categories – i.e., the existence of either something like c-selection and/or case-checking by the predicates.)

Under the ICCA, verbs are classified into different valence classes as in (68) below and have all the semantic information on its own. Accordingly, even if some of the arguments are not present on the surface, the meanings of each sentence are delivered correctly since the predicates carry all the semantic information they need.

(68)a. *Cheli-ka* Δ

Cheli-nom

Δ : Class 1 (kata ‘go’, ota ‘come’, wulta ‘cry’, khika khuta ‘is tall’ etc.)

b. *Cheli-ka* *sakwa-lul* Δ

Cheli-nom apple-acc

Δ : Class 2 (cohahata ‘like’, caluta ‘cut’, mekta ‘eat’ etc.)

c. *Cheli-ka* *Yenghi-eykey* Δ

Cheli-nom Yenghi-dat

Δ: Class 3 (insahata ‘greet’ etc.)

d. Cheli-*ka* Yenghi-*eykey* sakwa-*lul* Δ

Cheli-nom Yenghi-dat apple-acc

Δ: Class 4 (ponayta ‘send’, cwuta ‘give’ etc.)

e. Cheli-*ka* [Yenghi-*ka* yepputa]-*ko* Δ

Cheli-nom Yenghi-acc be.pretty-COMP

Δ: Class 5 (sayngkakhata ‘think’ etc.)

f. Cheli-*ka* [Yenghi-*ka* sakwa-*lul* cohahanta]-*ko* (Tongswu-*eykey*) Δ

Cheli-nom Yenghi-nom apple-acc like-COMP Tongswu-dat

Δ: Class 6 (malhata ‘tell’ etc.)

g. Cheli-*ka* Chinkwu-*ka* Δ

Cheli-nom friend-nom

Δ: Class 7 (philyohata ‘need’, kulipta ‘miss’ etc.)

Now, let us consider what the structure of “elliptical” sentences in (69-71) is like under the current approach. Here we consider answer parts only, which involve null arguments.

(69)Q: Nwuku-*ka* ku ppang-*ul* mek-*ess-ni*?

Who-nom the bread-acc eat-pst-Q

‘Who ate the bread?’

A: Cheli-ka mek-ess-e
C-nom eat-pst-decl

‘Cheli ate (the bread).’

(70)Q: Cheli-ka mwues-ul sa-ss-ni?
C-nom what-acc buy-pst-Q

‘What did Cheli buy?’

A: chayk-ul sa-ss-e
book-acc buy-pst-decl

‘(Cheli) bought a book.’

(71)Q: Cheli-ka ku cha-lul ettehkey hay-ss-ni?
C-nom the car-acc how do-pst-Q

‘What did Cheli do with the car?’

A: phal-ass-e
sell-pst-decl

‘(Cheli) sold (the car).’

Although the ‘elliptical’ sentences in (69-71) have linguistic antecedents for null arguments in the given contexts (due to Q-A pairs), what is noteworthy here is that none of the answer parts in (69-71) needs linguistic antecedents for the null elements. For example, ‘Cheli-ka mek-ess-e’ in (69) can be uttered grammatically by speaker A when he/she sees Speaker B holding an empty doughnut box. Likewise, ‘Chayk-ul sa-ss-e’ in (70) can be said by a son when his mom has found his piggy bank empty. The sentence composed of the single verb ‘phal-ass-e’ in (71) can be said by Speaker A when Speaker B finds Speaker A’s garage now empty where there used to

be a car. That is, the null arguments can be deictically interpreted without any syntactic representations such as *trace* or *pro*. This is predicted under the proposed system, where a verb is the only essential element for a unit to be considered a sentence and the verbs do not need to be saturated, i.e., verbs do not need to discharge all their theta roles to overt arguments or *pro*, since, in this system, predicates are not functors requiring their arguments syntactically.

Now, let us consider (72) first. In the feature structure (73) below, undischarged semantic roles/values that the verb possesses are represented by engraved letters. Still, the presence of the verbs makes us presuppose that in (73) “something” (bread in this context) has been eaten by Cheli.

(72)Q: Nwuku-ka ku ppang-ul mek-ess-ni?

Who-nom the bread-acc eat-pst-Q

‘Who ate the bread?’

A: Cheli-ka mek-ess-e

C-nom eat-pst-decl

‘Cheli ate (the bread).’

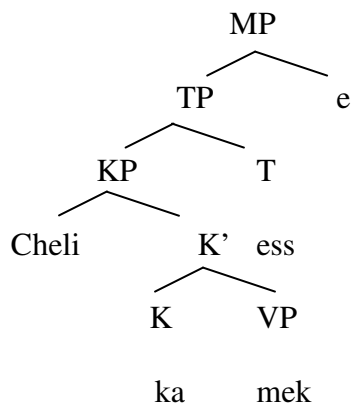

(73)

K:

PHON: /ka/
CAT: K_{NOM}
C-SEL: <D, K ∨ V>
PROBE: V-CL:
 { uV1
 { uV2
 { uV3
 { uV4... }

V:

CAT: /mek-/
V-CL: iV2
S-SEL: <D, D>

Likewise, in (74), we can conjecture, from the looks of the feature specification of the verb as in (75), that a book has been purchased by “someone” (‘Cheli’ in this context), which is marked engraved as an unsaturated argument of the verb (i.e., an undischarged semantic role of the verb).

(74)Q: Cheli-ka mwues-ul sa-ss-ni?

C-nom what-acc buy-pst-Q

‘What did Cheli buy?’

A: chayk-ul sa-ss-e

book-acc buy-pst-decl

‘(Cheli) bought a book.’

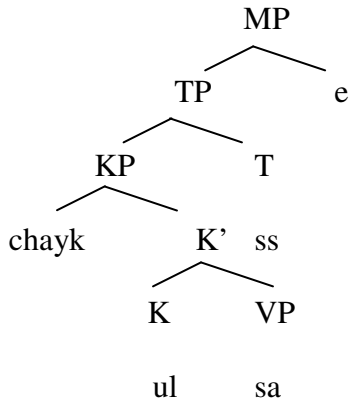

(75)

K:

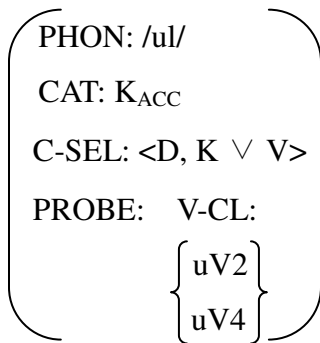

V:

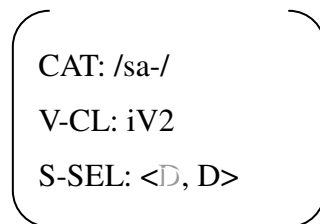

A verb alone can be an answer as in (76). Still, we can guess, through the feature structure of the verb as in (77), someone sold something. Given the context, we know that it is Cheli that sold the car.

(76)Q: Cheli-ka ku cha-ul ettehkey hay-ss-ni?

C-nom the car-acc how do-pst-Q

‘What did Cheli do with the car?’

A: phal-ass-e

sell-pst-decl

‘(Cheli) sold (the car).’

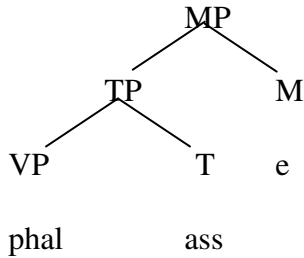

(77)

V:

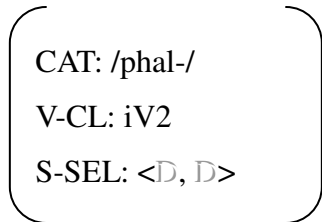

As we have seen so far, undischarged theta roles of a verb do not result in ungrammaticality (nonconvergence) as long as the sentence is interpretable. However, as we will see now, incompatibility in terms of C-selection results in ungrammaticality (though the resulting sentence might be interpretable). The answer in (78) is out due to the incompatibility between the KP and the following verb. Specifically, as shown in (79), the accusative case marker *Kacc* c-selects either Class 2 or Class 4 verbs, but the verb *cenhwaha-ta* ‘call’ belongs to Verb Class 3 as in (80), causing incompatibility and then resulting in ungrammaticality.

(78)Q: Cheli-ka nwukwu-eykey cenhwahay-ss-ni?
 Cheli-nom who-dat call-pst-Q

‘Who did Cheli call?’

A:* Yenghi-lul cenhwahay-ss-e.
 Yenghi-acc call-pst-decl

(79)

K:

PHON: /lul/
 CAT: K_{ACC}
 C-SEL: <D, K ∨ V>
 PROBE: V-CL:
 { uV2 }
 { uV4 }

(80)

V:
 CAT: /cenhwaha-/
 V-CL: iV3
 S-SEL: <D̄, D>

Missing arguments are found in an embedded clause as well, as exemplified in (81). As we see in the structure in (82), the missing object is not syntactically represented, yet we know that something was bought by ‘Yenghi’ by virtue of the feature structure of the embedded verb represented in (83).

(81)Q: Cheli-ka nwuku-ka ku chayk-ul sa-ss-ta-ko sayngkakha-ni?

Cheli-nom who-nom the book-acc buy-pst-decl-comp think-Q?

‘Who does Cheli think bought the book?’

A: Cheli-ka Yenghi-ka sa-ss-ta-ko sayngkakhay

C-nom Y-nom buy-pst-decl-comp think.decl

‘Cheli thinks Yenghi bought (the book).’

(82)

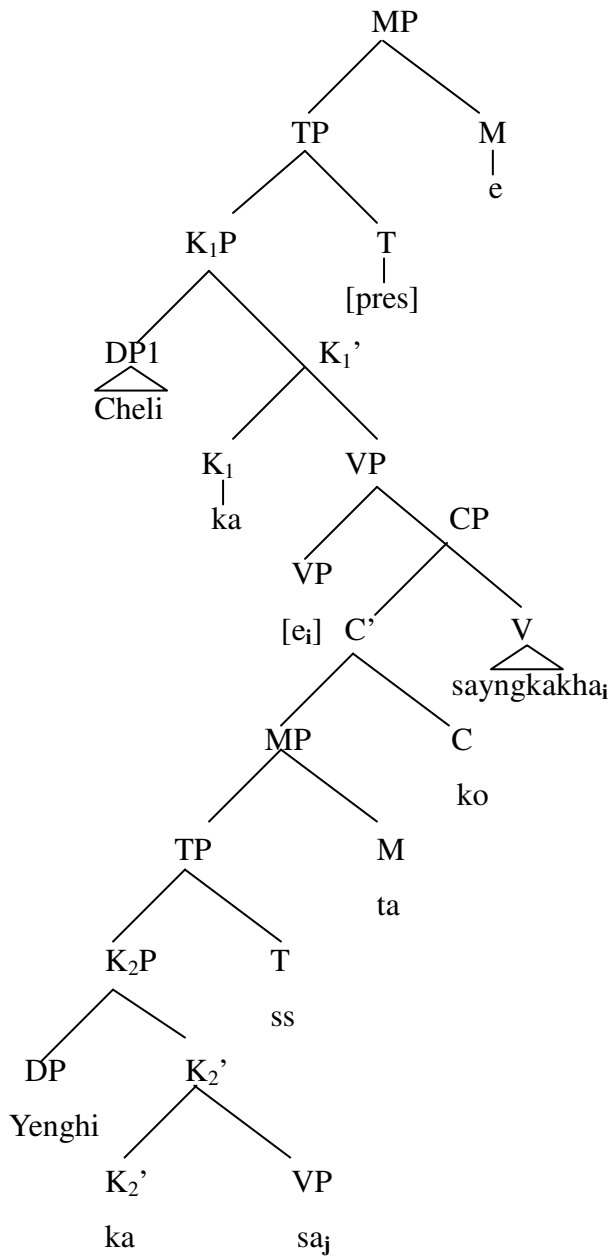

(83)K1:

PHON: /ka/
CAT: K_{NOM}
C-SEL: <D, K ∨ V>
PROBE: V-CL:
 { uV1
 uV2
 uV3
 uV4
 uV5
 uV6... }

V:
CAT: /sayngkakha-/
V-CL: iV5
S-SEL: <D, M>

K2:

PHON: /ka/
CAT: K_{NOM}
C-SEL: <D, K ∨ V>
PROBE: V-CL:
 { uV1
 uV2
 uV3
 uV4... }

V:
CAT: /sa-/
V-CL: iV2
S-SEL: <D, D>

Similarly, both a matrix subject and an embedded clause subject can drop, leaving a well-formed sentence as exemplified in (84). The feature specification of each verb in (85) shows that both the matrix clause subject and the embedded clause subject are semantically present as marked by engraving, though syntactically absent as depicted below.

(84)Q: ne-nun Yenghi-ka nwuku-lul coahay-ss-ta-ko sayngkakha-ni?

You-Top Y-nom who-acc like-pst-decl-comp think-Q?

‘Who do you think Yenghi liked?’

A: Cheli-lul coahay-ss-ta-ko sayngkakhay

C-acc like-pst-decl-comp think.decl

‘(I) think (Yenghi) liked Cheli.’

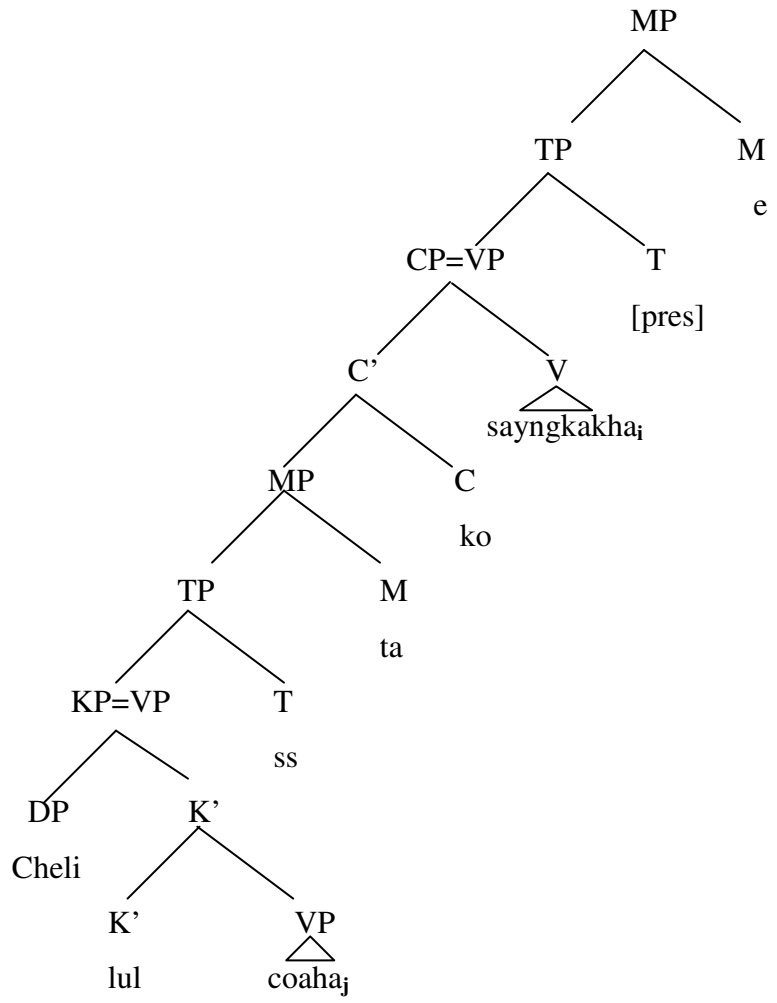

(85)K:

PHON: /lul/
 CAT: K_{ACC}
 C-SEL: <D, K ∨ V>
 PROBE: V-CL:
 { uV2 }
 { uV3 }
 { uV4... }

V:

CAT: /coaha-/
V-CL: iV2
S-SEL: <D, D>

V:

CAT: /sayngkakha-/
V-CL: iV5
S-SEL: <D, M>

Only a series of verbs makes a perfectly well-formed sentence as shown in (86). In this case as well, all the missing arguments are semantically present as represented in the feature specification of the verbs in (87-88) and the intended meaning is properly obtained.

(86)Q: ne-nun Cheli-ka Yenghi-lul silhehay-ss-ta-ko sayngkakha-ni?

You-Top C-nom Y-acc hate-pst-decl-comp think-Q?

‘Do you think Cheli hated Yenghi?’

A: ani, coahay-ss-ta-ko sayngkakhay.

No like-pst-decl-comp think.decl

‘No, (I) think (he) liked (her).’

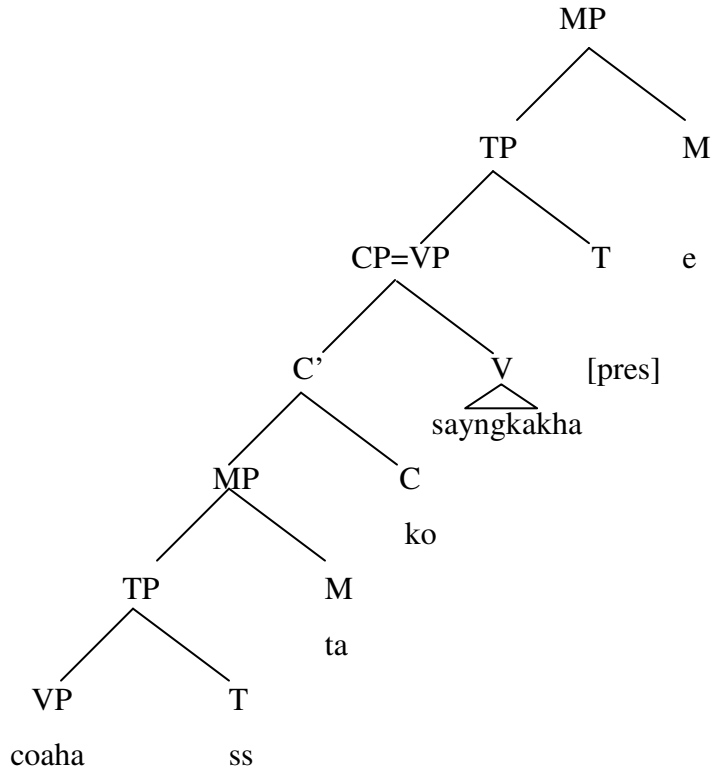

(87)V:

(CAT: /coaha-/
 V-CL: iV2
 S-SEL: <D, D>

(88)V:

(CAT: /sayngkakha-/
 V-CL: iV5
 S-SEL: <D, M>

So far, we have examined ‘ellipsis’ of various phrases in Korean including case-marked NPs or CPs. Considering that verbs do not carry agreement morphemes in Korean (except the honorific

agreement morpheme *-si*), it is notable that arguments drop so freely without resulting in ungrammaticality of a sentence in Korean. That is, the combination of a subject and a transitive verb, without an object, can make a well-formed sentence. Also, a sequence of an object and a verb can serve as an acceptable sentence in Korean. Not only a single verb but also a series of verbs can stand by themselves and be a perfect sentence in Korean. However, none of these instances are acceptable in English. All of these show that only a verb is an essential element to form a syntactic sentence in Korean, while all the arguments of a verb should be present to be a well-formed sentence in English. These interesting facts are properly explained under the proposed system, where the verb semantically, not syntactically, selects its arguments and does not need to be saturated, i.e., does not need to discharge all their theta roles to overt arguments or *pro*. In sum, a single argument or a series of arguments, each case-marked, is an elliptical construction with an empty verb syntactically, while a verb or a series of verbs is not an elliptical sentence containing empty structural slots. The ‘elliptical’ arguments in J/K are not syntactically present at all though semantically present, as represented by the feature specifications of verbs.

So far I discussed what the structure of the Host of RD would be like by first looking into null argument constructions because the Host usually involves null arguments. I proposed that the gap in the Host is not syntactically represented. That is, missing arguments mean structural absence of them. This is compatible with the evidence given in Sells’s (1999) evidence against positing a gap in the Host clause in RD constructions in Korean and Japanese. In the next subsection, I will provide evidence for the null (verbal and nominal) predicate in the appendix part.

4.2 The Appendix: Evidence for Null Verbal/Nominal Predicates in the Appendix

I posited a null predicate in the appendix part based on the following observations. First, the null predicate can optionally be realized as a full phrase. That is, the Appendix can be followed by an overt predicate identical to and coindexed with the predicate in the Host clause as exemplified and italicized in (89-90). This shows that there is a covert phrase following the appendix which is sometimes realized as an overt form.

- (89)a. Cheli-ka ___ *ttayli-ess-e* sacangnim atul-ul
 Cheli-nom hit-pst-decl president son-acc
 ‘Cheli hit the son of the company boss.’
- b. Cheli-ka ___ *ttayli-ess-e* sacangnim atul -ul *ttayli-ess-e*
 Cheli-nom hit-pst-decl president son-acc hit-pst-decl
- c. Cheli-ka ___ *ttayli-ess-e_i* sacangnim atul -lul *kulay-ss- e_i*
 Cheli-nom hit-pst-decl president son-acc do.so-pst-decl
- (90)a. ppang-ul mek-ess-e Cheli-ka
 bread-acc eat-pst-decl Cheli-nom
 ‘Cheli ate bread.’
- b. ppang-ul *mek-ess-e* Cheli-ka *mek-ess-e*
 bread-acc eat-pst-decl Cheli-nom eat-pst-decl
- c. ?ppang-ul *mek-ess- e_i* Cheli-ka *kulay-ss- e_i*
 bread-acc eat-pst-decl Cheli-nom do.so-pst-decl

Likewise, a locally licensed nominal null predicate can optionally be realized as an overt noun as

italicized in (91).

(91)a. Na-to anay-ka philyoha-y chakha-ko sallim cal ha-nun
I-also wife-nom need-decl be.nice-conj house.work well do-REL

‘I too want to get married, to a nice woman who’s good around the house.’

b. Na-to *anay-ka* philyoha-y chakha-ko sallim cal ha-nun *anay*
I-also wife-nom need-decl be.nice-conj house.work well do-REL wife

‘I too want to get married, to a nice woman who’s good around the house.’

Second, the appendix can appear even when the Host is a completely well-formed sentence with no missing arguments or adjuncts at all. Still, the element coreferential with (or corresponding to) one of the arguments or adjuncts of the Host can appear as an appendix, as exemplified and italicized in (92). This reflects an independent existence of a null verbal or a null nominal predicate in relation to which the appendix can get interpreted. Otherwise, there is no place in the Host for the appendix to go to for its interpretation.

(92) a. Arguments:

Yenghi-ka *ku ay-lul* cham silhe-hay *Cheli-lul*
Y-nom the guy-acc really hate-decl C-acc

‘Yenghi really hates the guy, Cheli.’

ku ay-ka Yenghi-lul cham silhe-hay *Cheli-ka*
the guy -nom Y-acc really hate-decl C-nom

‘Yenghi really hates the guy, Cheli.’

b. Adjuncts:

Yenghi-ka *kulehkey* ttenapeli-ess-e *maycenghakey*

Y-nom so leave-pst-decl heartlessly

‘Yenghi left so -- heartlessly.’

c. Adnominals:

Na-nun *kulen* salam-i coh-a chakha-ko *hyenmyengha-n*

I-Top such person-nom like-decl be.nice-conj be.wise-rel

‘I like such a person – that is nice and wise.’

d. Embedded clauses:

Na-nun *kulehkey* sayngkakha-y *kenkang-i* *ton-pota*

I-Top so think-decl health-nom money-than

cwungyoha-ta-ko

be.important-decl-comp

‘I think so – health is above wealth.’

So far we have considered what the structures of the Host and the Appendix part should be like. Based on the structures proposed above for the Host and the Appendix, let us consider in following sections in more detail how the appendix, single or multiple, is interpreted in examples with various kinds of appendices – adnominals, adverbials, NPIs, WH phrases etc. As to the interpretation, we will consider some issues on local and long distance dependencies, heaviness and closeness constraints, WH-phrase and NPI phrase licensing in RD constructions.

4.3 Right-Dislocations with a Single Appendix

Let us consider how the RD constructions in (93) with a single appendix are accounted for under the ICCA.

- (93) Cheli-ka ilk-ess-ta ku chayk-ul
 C-nom read-pst-decl the book-acc
 ‘Cheli read the book.’

The host clause comprises a clause and the appendix clause another clause as illustrated in (94). I assume the whole sentence forms a discourse unit (marked as E³¹), not a syntactic constituent.

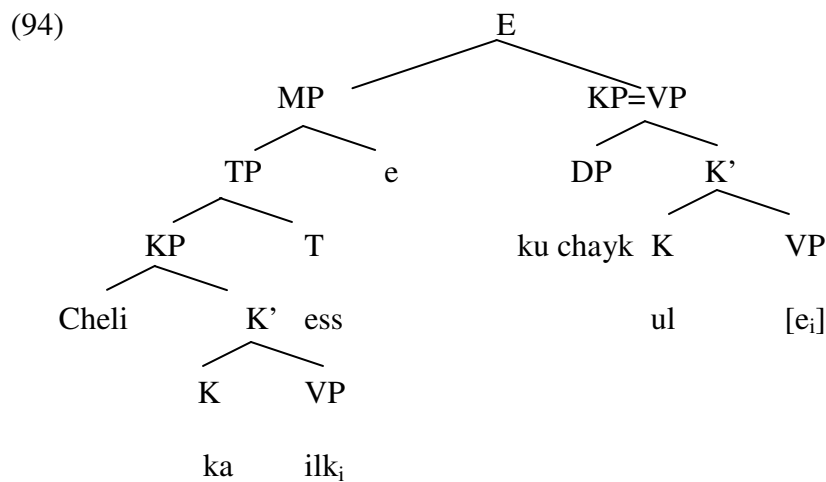

Following are examples where the appendix is a relative clause, a possessor or a determiner. As shown in Chapter 2, they are all combinatoric markers and are assigned feature specifications.

³¹ As we assume that E is a discourse unit, not a syntactic constituent, it is naturally explained that right-dislocation does not occur in embedded contexts as previously discussed. (See the example presented as violation of RRC. If an RD occurs in an embedded context, observing RRC, there is no way to rule out examples such as (i).

- (i)* Cheli-ka Yenghi-ka manna-ss-ta-ko Tongswu-lul malhay-ss-ta
 Cheli-nom Y-nom meet-pst-decl-comp T-acc say-pst-decl

The Relativizer *-nun* in (95) has the specification in (96) and licenses a null noun [e] as its sister. The null noun [e] now searches for an NP ‘*sose*l’ in the host to be co-indexed with and be interpreted, as schematized in (97).

(95) na-nun [____ *sose*l]-ul ilk-ess-e, acwu caymi iss-nun
 I-Top novel-acc read-pst-decl very interesting
 ‘I read a novel that is very interesting.’

(96) Relativizer (REL) *-(nu)n*

REL:

PHON: /nun/
 CAT: R
 C-SEL: <T ∨ M, D>
 PROBE: ____

(97) [MP na-nun [____ *sose*l_i]-ul ilk-ess-e] [RP acwu caymi iss-**nun** [e_i]
 I-Top novel-acc read-pst-decl very interesting-Rel
 ‘I read a novel that is very interesting.’

Similarly, the genitive marker *-uy* in (98) has the following specification in (99) and licenses a null noun as its sister as in (100). The null noun [e] now searches for an NP in the host to be co-indexed with and get interpreted as shown in (100).

(98) na-nun [____ *cha*]-lul pilli-ess-e Tongswu-uy
 I-Top car-acc borrow-pst-decl Tongswu’s
 ‘I borrowed Tongswu’s car.’

(99) Genitive Case-marker (K_{GEN})

(PHON: /uy/
 CAT: K_{GEN}
 C-SEL: <D, D>
 PROBE: _____)

(100) [$_{MP}$ na-nun [_____ cha_i]-lul pilli-ess-e] [$_{KP}$ Tongswu-**uy** [e_i]]

I-Top car-acc borrow-pst-decl Tongswu's

'I borrowed Tongswu's car.'

The determiner in (101) has the following specification in (102) and licenses a null noun [e] as its sister. The null noun [e] now searches for an NP in the host to be co-indexed with and get interpreted as schematized in (103).

(101) na-nun [___ chayk]-ul te sa-ya toy ilen (conglyu-uy)

I-Top book-acc more buy-have.to this (kind of)

'I have to buy this kind of book more.'

(102) Determiner (DET) *-i, ku*

(PHON: /ku/
 CAT: DET
 C-SEL: < \emptyset , N>
 PROBE: _____)

(103) [$_{MP}$ na-nun [___ $chayk_i$]-ul te sa-ya toy] [$_{DetP}$ ilen (conglyu-uy) [e_i]]

I-Top book-acc more buy-have.to this (kind of)

'I have to buy this kind of book more.'

Under the Incremental C-selectional Combinatoric Analysis, RD constructions are base-generated as a bi-clausal structure, where the second clause contains a null predicate or a null noun whose contents are resolved by virtue of the feature specifications of the licenser (that is, the combinatoric marker in the appendixin relation to the Host).

4.4 Right-Dislocations with Multiple Appendices

Let us now consider RDs with multiple appendices as in (104-105). Simialr to the examples with a single appendix, the appendices comprise a separate clause from the Host. Specifically, the two appendix KPs combine and then license a null predicate, which is co-indexed with an overt predicate in the Host clause and is interpreted.

- (104) Cheli-ka cwu-ess-e Tongswu-eykey chayk-ul
 C-nom give-pst-decl T-dat book-acc
 ‘Cheli gave Tongswu a book.’

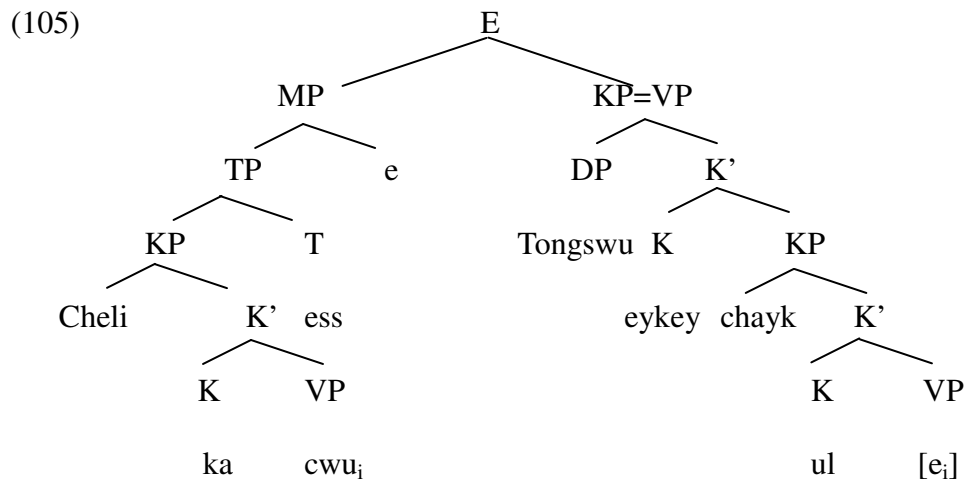

Example (106) is analyzed in a similar fashion; the appendices license a null predicate, which

forms a separate clause, as depicted in (107).

- (106) chayk-ul cwu-ess-e Cheli-ka Tongswu-eykey
 book-acc give-pst-decl C-nom T-dat
 ‘Cheli gave Tongswu a book.’

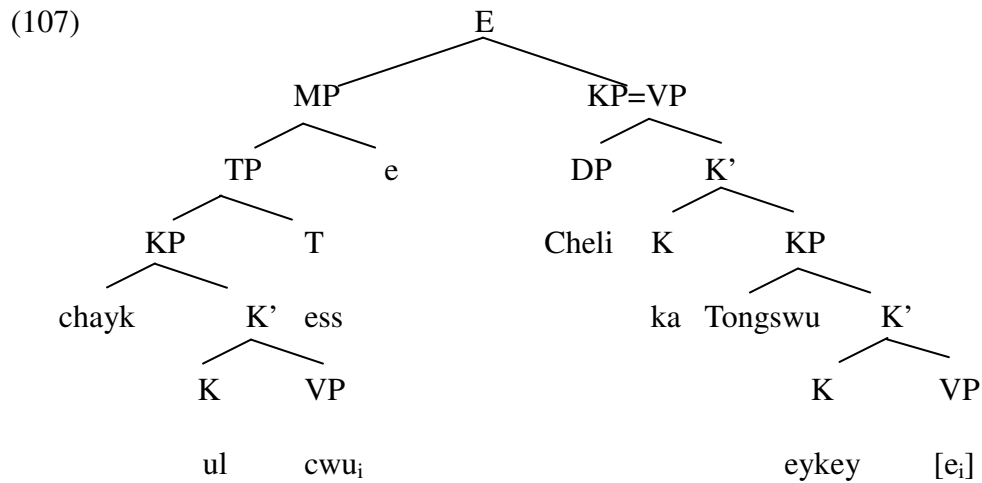

Let us now consider RD constructions with an embedded clause and how the proposed system accounts for those with multiple appendices as in (108-109).

- (108) Cheli-ka [Yenghi-ka ponay-ss-ta]-ko malhay-ss-eyo,
 Cheli-nom Y-nom send-pst-decl-comp say-pst-decl
 Suni-eykey kkoch-ul
 S-dat flowers-acc
 ‘Cheli said that Yenghi sent Suni flowers.’

- (109) * Cheli-ka [Yenghi-ka manna-ss-ta]-ko malhay-ss-eyo,
 Cheli-nom Y-nom meet-pst-decl-comp say-pst-decl

Suni-eykey Tongswu-lul

S-dat T-acc

The example in (108) is analyzed as in (110), for example, where the KP clusters in the appendix search for a compatible predicate to combine with and license a null predicate [e]. The null predicate is then unified with the Class 4 verb ‘ponayta’ in the host clause as the KP clusters, according to the verb classification, are compatible with the class 4 verbs, and the appendix now gets interpreted.

(110)

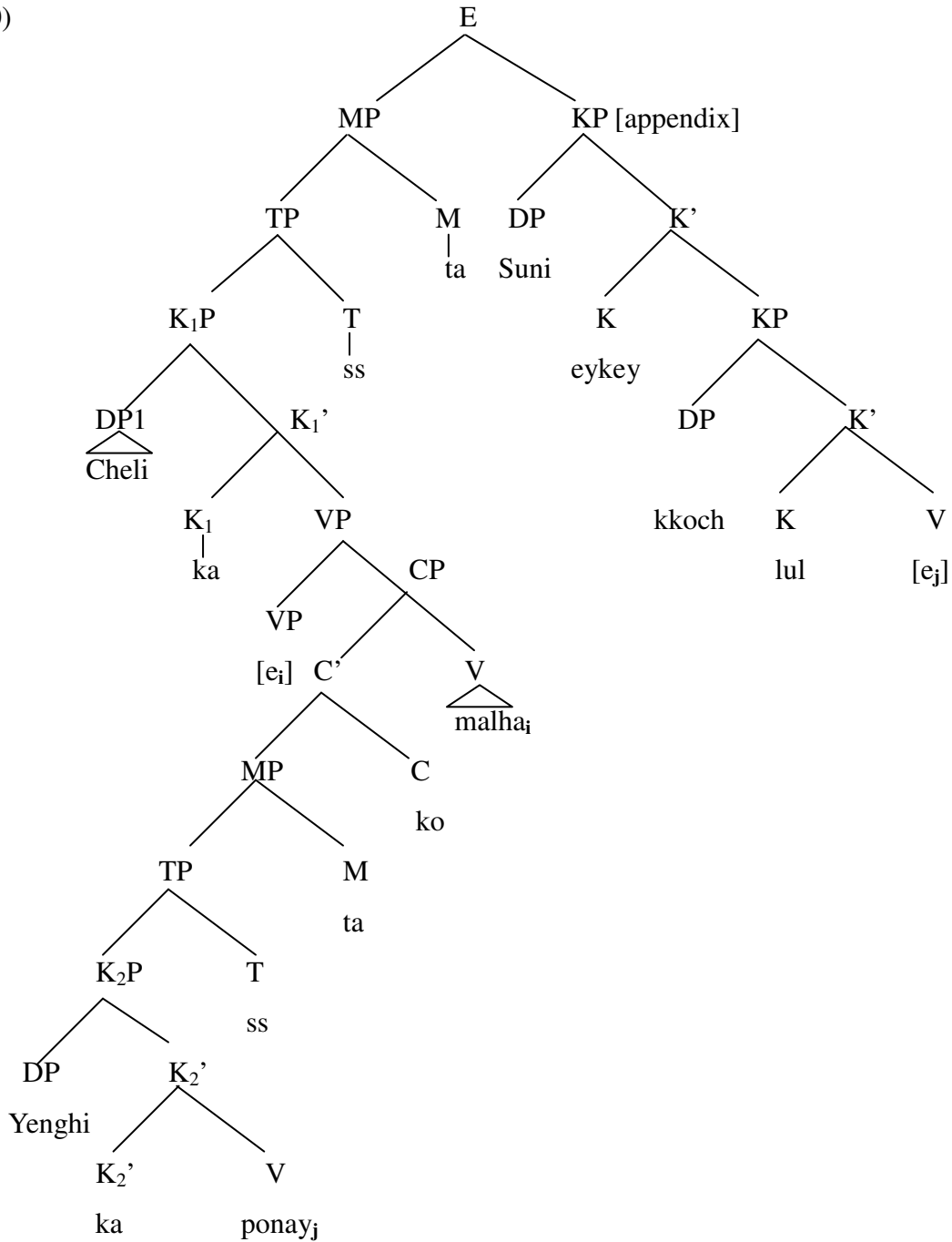

However, (109) is analyzed as (111), which is ruled out due to the incompatibility between the KP clusters and the predicate. Specifically, the KP clusters in the appendix expect class 4 verbs and search for them, which are not found in the host clause.

(111)

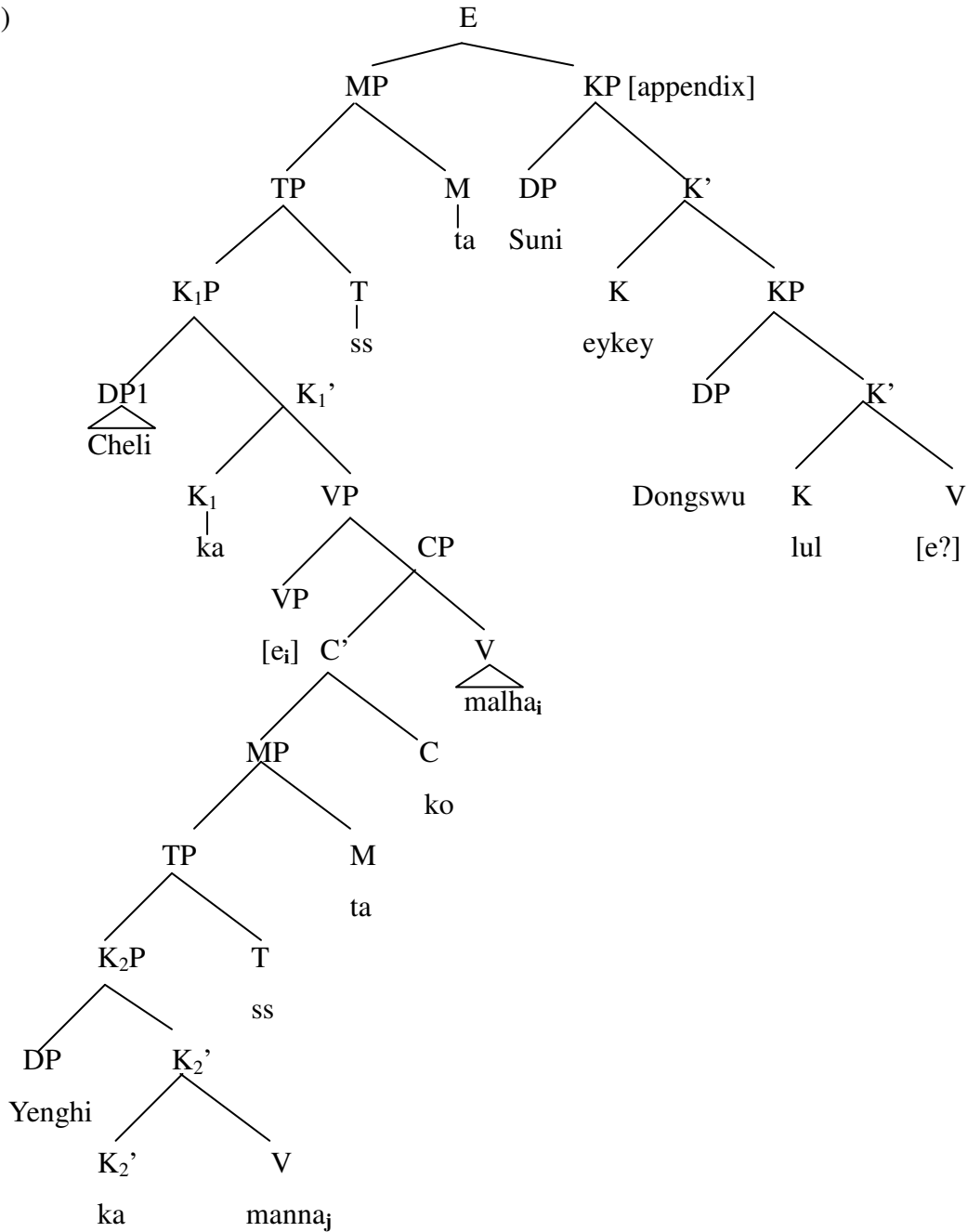

However, as pointed out above, we can make the two KPs in (112) into two separate clauses with a pause, making each KP license its own predicate, as illustrated in (113). Now the sentence becomes acceptable, confirming the discussions above.

(112) Cheli-ka [Yenghi-ka manna-ss-ta]-ko malhay-ss-eyo

Cheli-nom Y-nom meet-pst-decl-comp say-pst-decl

Suni-eykey Tongswu-lul

S-dat T-acc

(113)

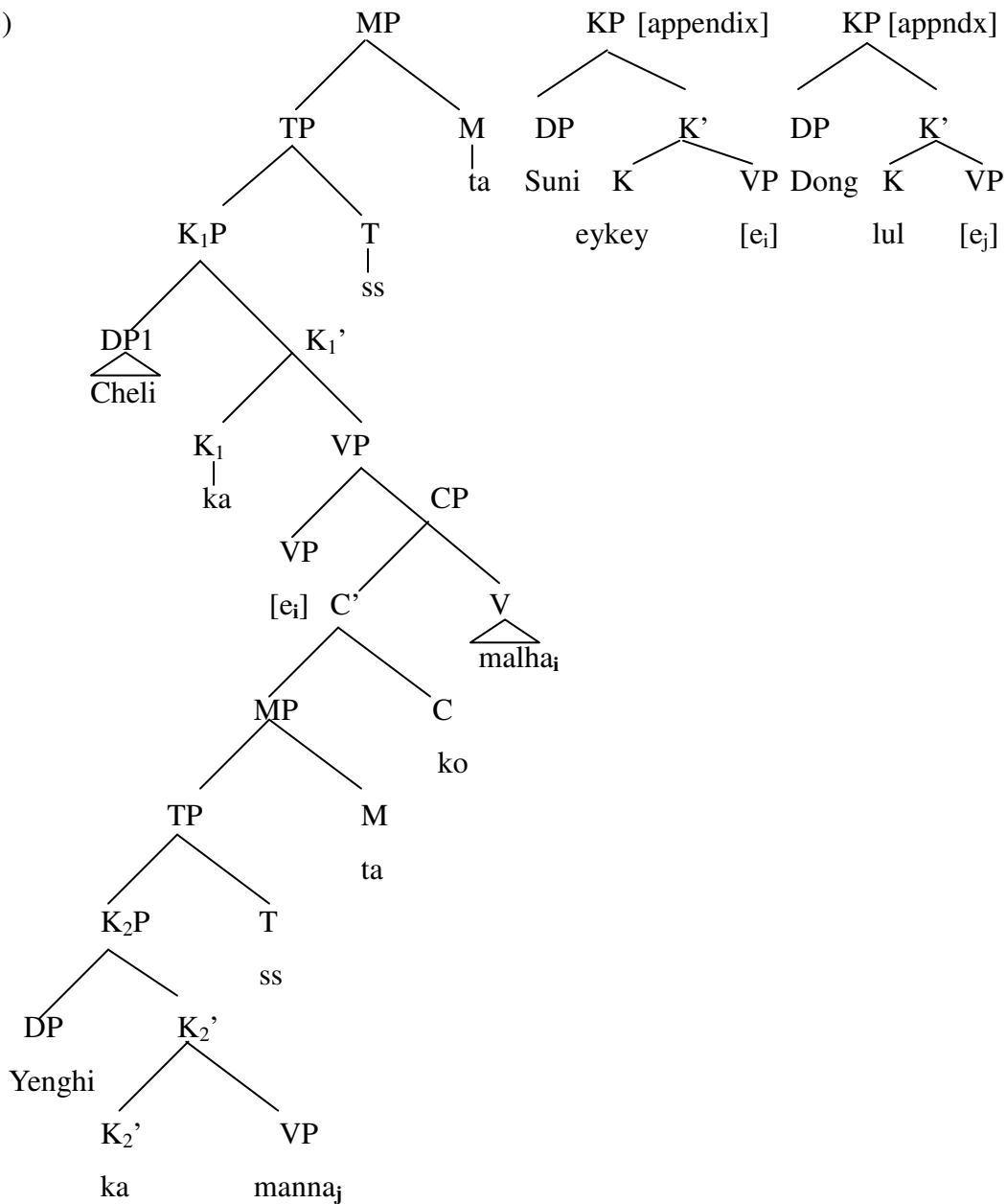

Let us consider some examples with RD iteration, where each appendix is related to the

immediately superordinating clause. In (114), for example, ‘Cheli-ka manna-ss-ta-ko’ is related to ‘Na-nun sayngkakha-n-ta’ and ‘Tongswu-lul’ is related to ‘Cheli-ka manna-ss-ta-ko’. That is, RD is applied in an iterative manner.

(114) Na-nun sayngkakha-n-ta, Cheli-ka manna-ss-ta-ko, Tongswu-lul
 I-Top think-pres-decl C-nom meet-pst-decl-comp T-acc
 ‘I think that Cheli met Tongswu.’

The proposed analysis accounts for example (114) as illustrated in (115). First, the host clause is formed. Then each appendix clause forms its own clause, each licensing a null predicate. The first occurrence of the null predicate is unified with ‘sayngkakhata’ as the CP is compatible with the Class 5 verb ‘sayngkakhata’. The second occurrence of the null predicate first searches the adjacent clause and finds an overt predicate ‘mannata’. As they are compatible with each other, the contents of the null predicate are resolved.

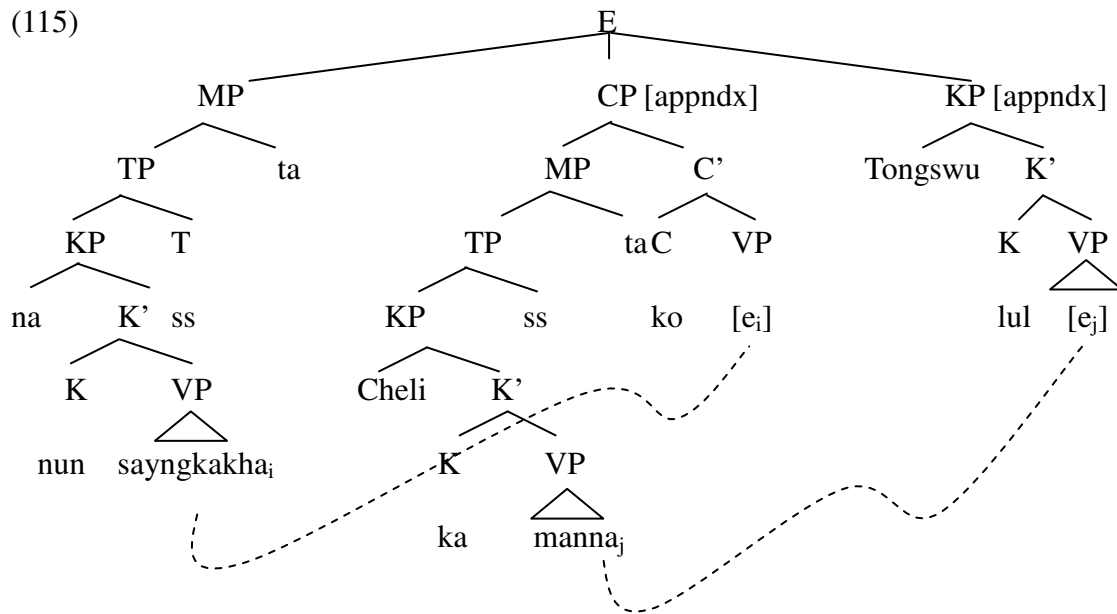

Now let us consider another example (116) that is explained in a similar fashion. First, the host clause is formed. Then each appendix clause is formed, each licensing a null predicate as illustrated in (117). The first occurrence of the null predicate is unified with ‘malhata’ as the CP is compatible with the Class 6 verb ‘malhata’. The second occurrence of the null predicate first searches for and finds an overt predicate ‘mannata’ within the adjacent clause, but as they are incompatible, it continues searching for another overt predicate and finds ‘malhata’ in the next clause. This time, they are compatible with each other and the contents of the null predicate are resolved.

(116) Na-nun malhay-ss-ta, Cheli-ka Tongswu-lul manna-ss-ta-ko, Suni-eykey
 I-Top tell-pst-decl C-nom T-acc meet-pst-decl-comp S-dat
 ‘I told Suni that Cheli met Tongswu.’

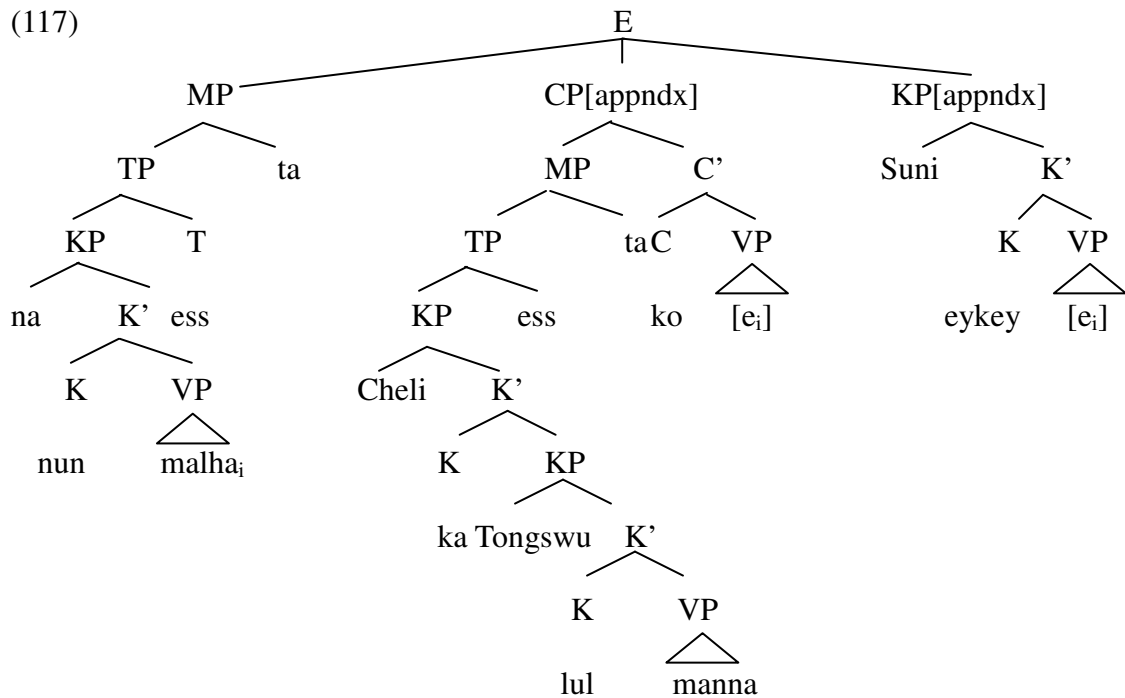

So far we have considered sentences composed of a matrix clause and an embedded clause within the matrix VP. Now we consider examples with an embedded clause within a DP. First, let us examine examples with a single appendix as in (118).

- (118) a. Cheli-ka caknyen-ey [[Toyota-ka mantu-n] cha]-lul sa-ss-ta
 C-Nom last.year T-nom make-REL car-acc buy-Pst-decl
- b. Cheli-ka caknyen-ey cha-lul sa-ss-ta Toyota-ka mantu-n
 C-Nom last.year car-acc buy-Pst-decl T-nom make-REL

First, the host clause is formed and the appendix clause is formed, licensing a null noun [e] as in (120). As the feature specification of the combinatoric marker REL in (119) shows, [e] in (120) should expect an NP to combine with it and is resolved to ‘cha’, as it is semantically the most plausible antecedent.

(119) Relativizer (REL) *-(nu)n*

REL:

$$\left(\begin{array}{l} \text{PHON: /nun/} \\ \text{CAT: R} \\ \text{C-SEL: } \langle T \vee M, D \rangle \\ \text{PROBE: } \underline{\quad} \end{array} \right)$$

(120)

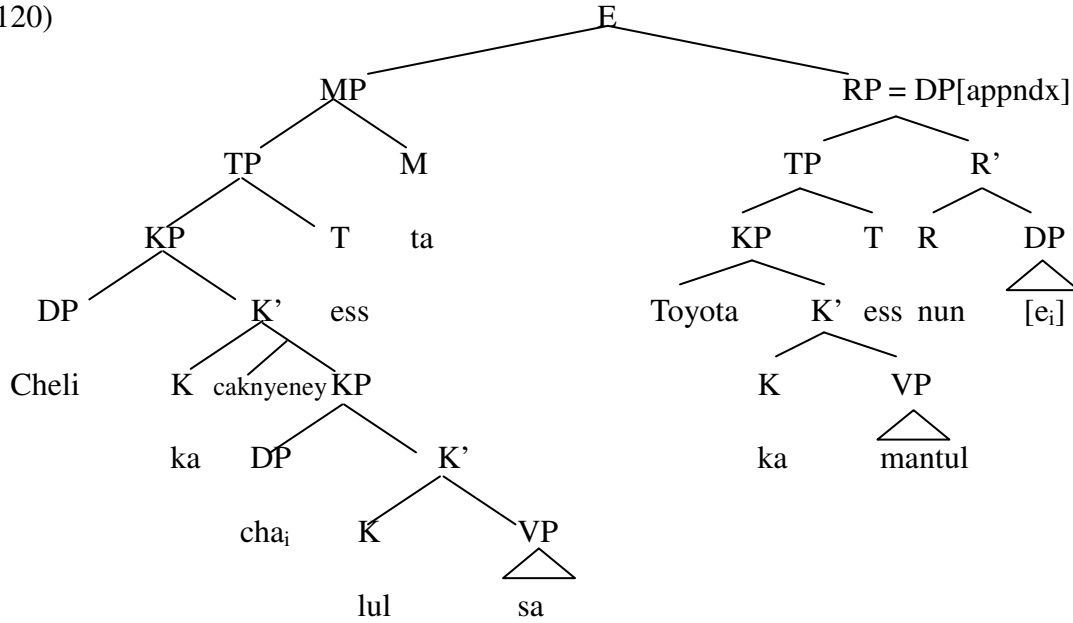

Now consider (121), where an adverb is RD-ed. First, the host clause is formed and the appendix clause is formed, licensing the null predicate [e] as in (122). The null predicate [e] searches for an overt predicate in the host clause. As there are two overt predicates in the host clause, both of them are candidates, making this sentence ambiguous between the reading ‘Last year Cheli bought a car Toyota made.’ And the reading ‘Cheli bought a car Toyota made last year.’ Of course, for some independent reasons, the latter reading is not as easy to get as the former. I will discuss this in detail in the next section.

- (121) a. Cheli-ka caknyen-ey [[Toyota-ka mantu-n] cha]-lul sa-ss-ta
 C-Nom last.year T-nom make-REL car-acc buy-Pst-decl
- b. Cheli-ka Toyota-ka mantu-n cha-lul sa-ss-ta caknyen-ey
 C-Nom T-nom make-REL car-acc buy-Pst-decl last.year

(122)

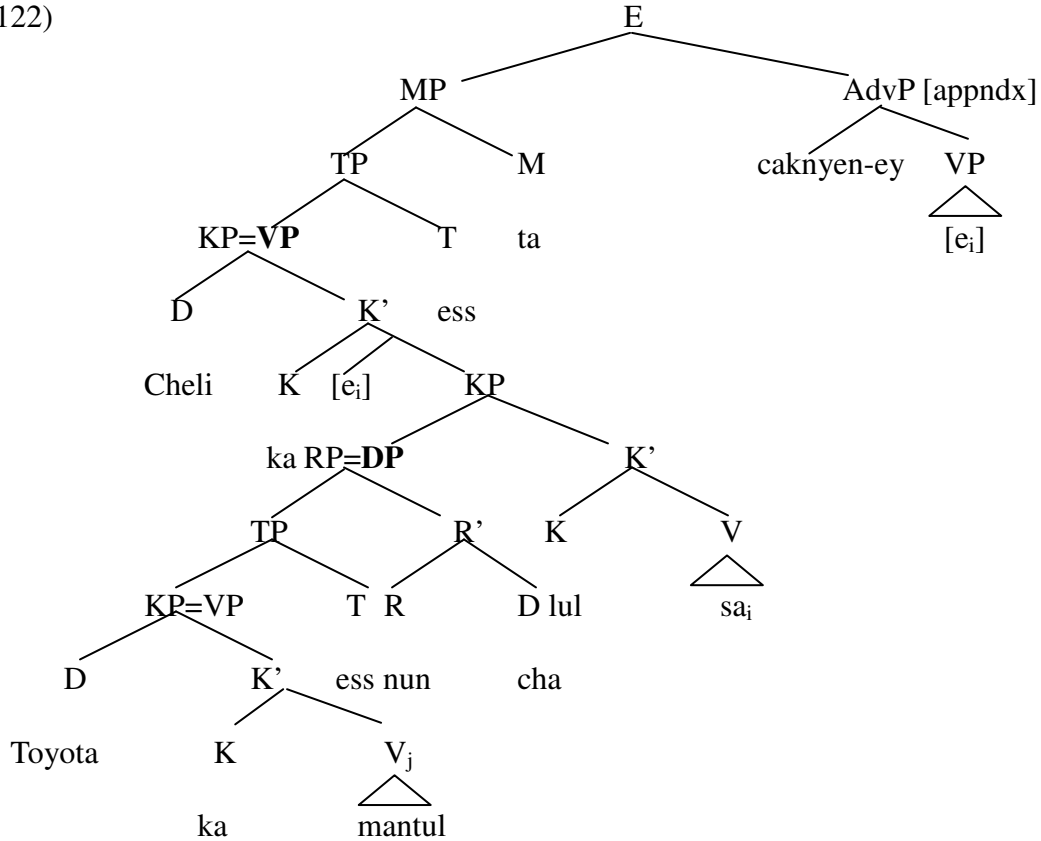

Multiple appendices are also possible as in (123) with an adnominal and an adverbial.

- (123)a. Cheli-ka caknyen-ey [[Toyota-ka mantu-n] cha]-lul sa-ss-ta
 C-Nom last.year T-nom make-REL car-acc buy-Pst-decl
- b. Cheli-ka cha-lul sa-ss-ta/ caknyen-ey/ Toyota-ka mantu-n
 C-Nom car-acc buy-Pst-decl last.year T-nom make-REL

Specifically, in (123b), two appendices *caknyen-ey* and *Toyota-ka mantu-n* are related to two different clauses – MP and DP respectively. In this example, the presence of pause is crucial; when there is a pause, it makes it impossible for the adverb to combine with the following clause,

having the adverb license a null predicate [e]. Then we get an interpretation that Cheli bought a car last year, which Toyota made. However, when there is no pause after *caknyeney* in (123b), the adverb can combine the following KP and then takes the predicate ‘mantulta’. We now obtain the reading that Cheli bought a car that Toyota made last year. Also, the cataphoric vs. anaphoric resolution of the null predicate [e] is confirmed again by this example. As discussed above, the null predicate [e] is resolved cataphorically if the resolution proceeds within a sentence, but is resolved anaphorically when it is located separately outside of the clause/sentence, where the overt predicate is present, as in constructions such as Fragments and RDs. For instance, let us consider (124) again, which is analyzed as in (125).

- (124) Cheli-ka cha-lul sa-ss-ta, caknyen-ey, Toyota-ka mantu-n
 C-Nom car-acc buy-Pst-decl last.year T-nom make-REL
- (125) Cheli-ka cha-lul sa_i-ss-ta, caknyen-ey [e_i],
 C-Nom car-acc buy-Pst-decl last.year
 Toyota-ka mantu_j-n
 T-nom make-REL

Here, there are two candidates of overt predicates that [e] in (125) should be co-indexed with – ‘sa-ta’ and ‘mantul-ta’. As the null predicate is located separately outside of both of the clauses where the overt predicate is present, it should be resolved anaphorically to ‘sa-ta’, not ‘mantul-ta’.

Now we also need to resolve the [e] following the predicate ‘mantul-ta’ in (126). As the feature specification of the combinatoric marker REL in (127) shows, it [e] should expect an NP to

combine, being resolved to 'cha', which is semantically the most plausible antecedent.

(126) Cheli-ka cha-lul sa_i-ss-ta, caknyen-ey [e_i],

C-Nom car-acc buy-Pst-decl last.year

Toyota-ka mantu_j-n [e]

T-nom make-REL

(127)Relativizer (REL) *-(nu)n*

REL:

PHON: /nun/
CAT: R
C-SEL: <T ∨ M, D>
PROBE: _____

The analysis is illustrated in (128).

(128)

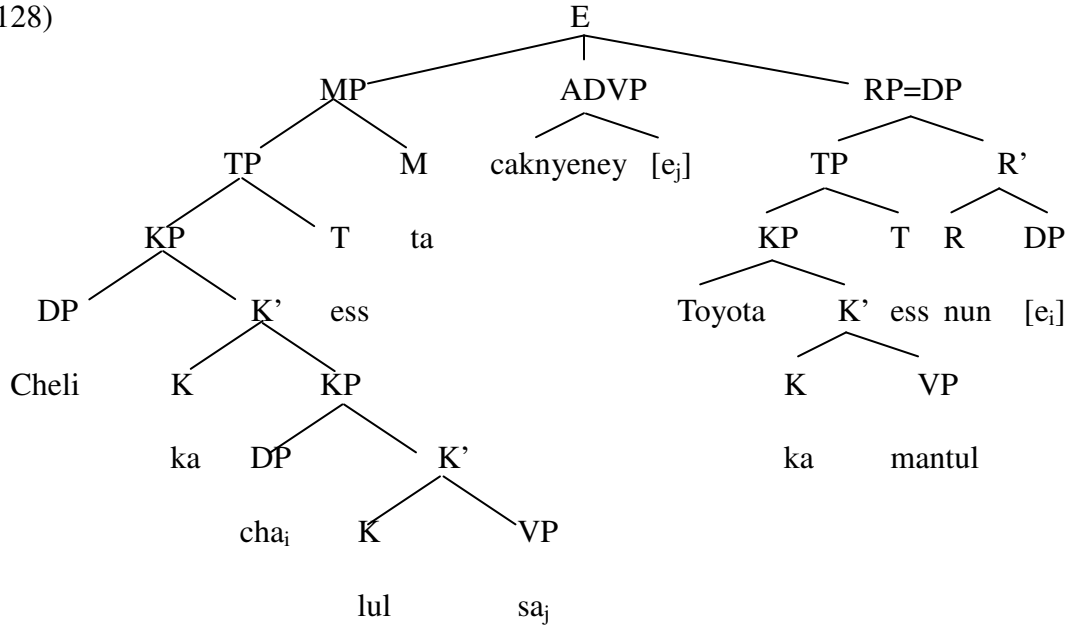

4.5 Island-like Effects

We turn now to the subjacency-like effects discussed above. Under the proposed analysis, everything is base-generated, so conditions such as subjacency are not needed as they are under movement analyses. However, some subjacency-like effects are observed when the dislocated elements get interpretation in the host clause. In RD constructions, the appendix searches for an interpretive spot in the host clause. Informally put, the appendix cannot receive interpretation in the host clause if the interpretive spot is embedded to a greater extent than optimal.

The appendix can receive interpretation if the gap is in a sentential subject or a complement clause, as we see in (129).

The appendix finds difficulty if the gap is in a complex NP clause as we see in (130).

The appendix cannot get easily interpreted if the gap is in a sentential subject or a complement clause that is embedded too deeply, as we see in (131).

Our analyses of (129a), (130a) and (131a) are illustrated in (129b), (130b) and (131b)

respectively for ease of exposition.

- (129) a. Cheli-ka [Yenghi-ka ____ manna-ss-ta]-ko
C-nom Y-nom meet-pst-decl-comp
sayngkakhay-ss-ta, Tongswu-lul
think-pst-decl T-acc
'Cheli thought that Yenghi met Tongswu.'

b.

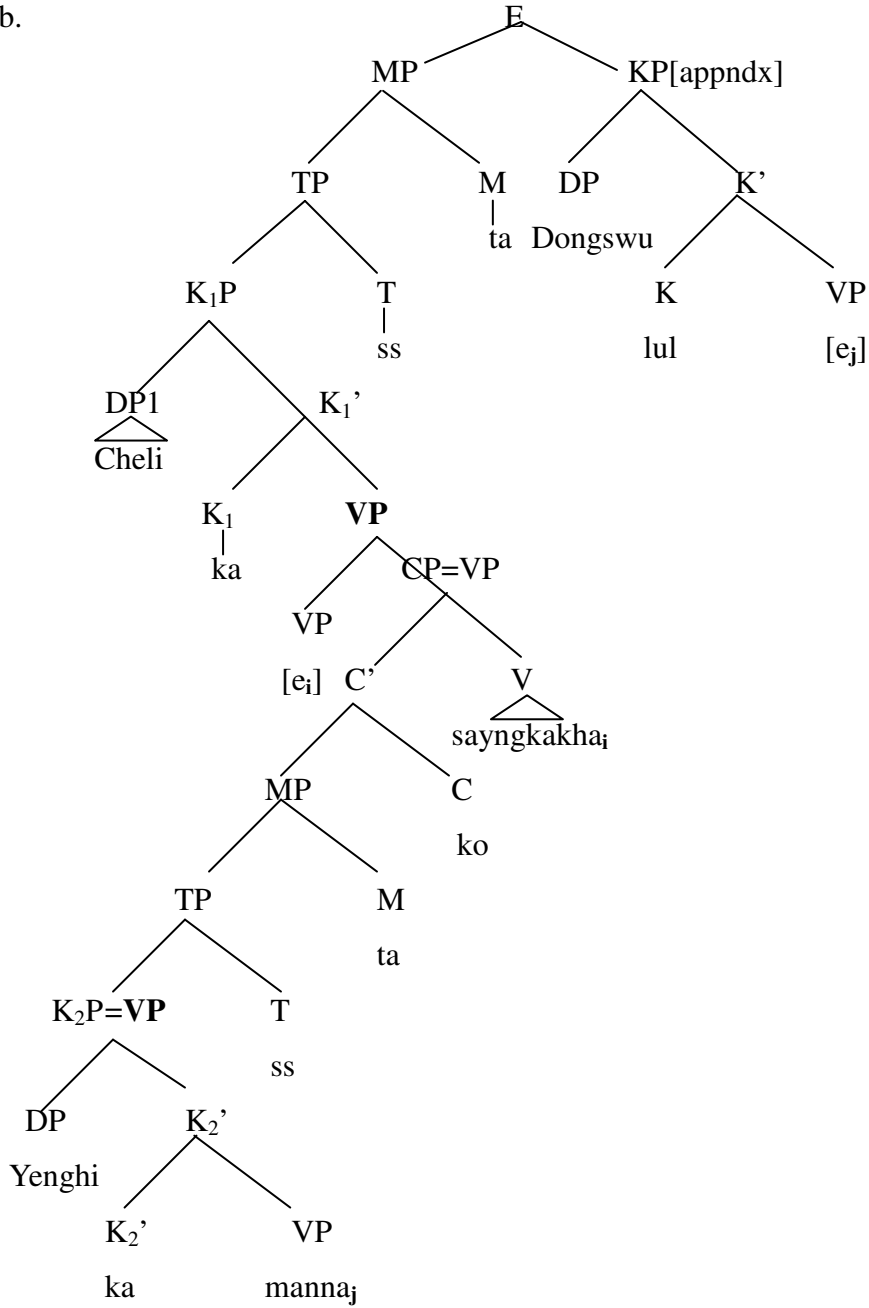

As illustrated above, for the appendix in (129) to get interpreted, it is allowed to cross two VPs, which is a legitimate process. Now, consider (130a).

(130)a.?^{*} Cheli-ka [Suni-ka coaha-n-ta]-nun somwun-ul

C-nom S-nom like-pres-decl-Rel rumor-acc

tul-ess-ta Tongswu-lul

hear-pst-decl T-acc

b.

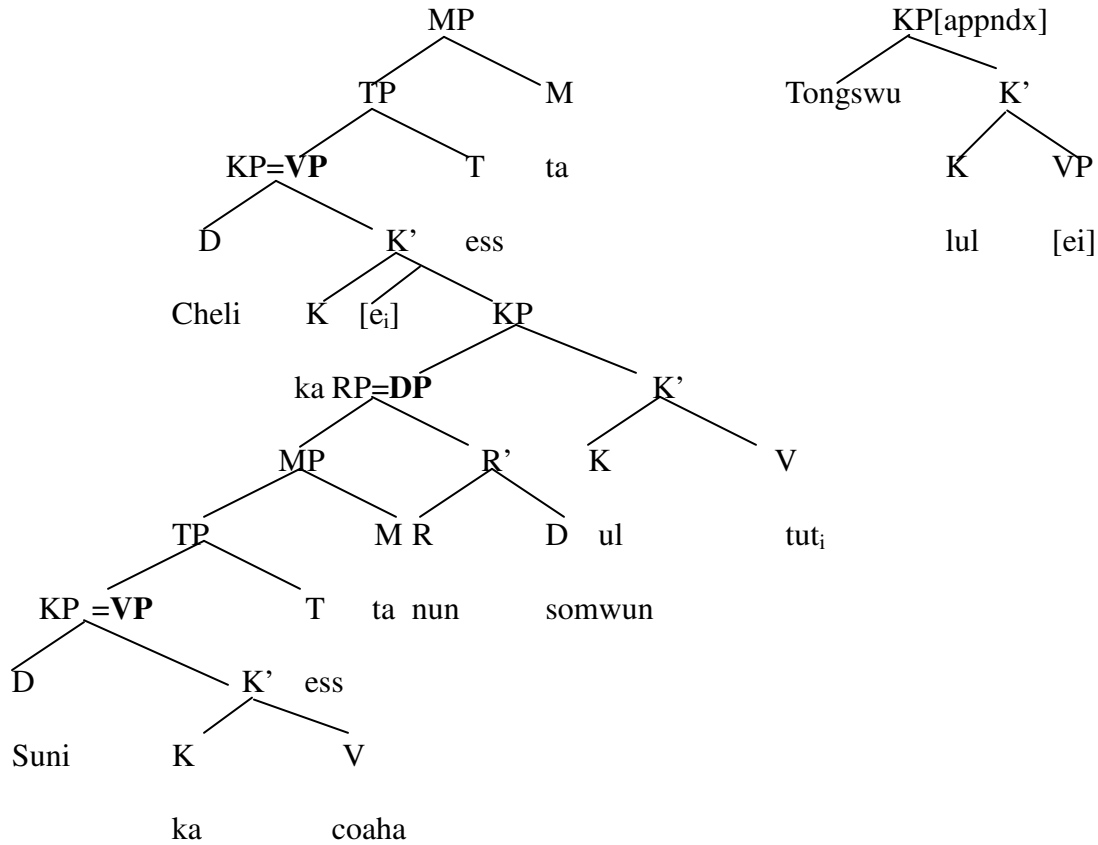

As represented in the tree structure above, for the appendix in (130b) to get interpreted, it has to cross VP, DP and the VP again, which is hard, hence the unacceptability of it. Now, consider (131a).

(131) a. *[Cheli-ka [(Sumi-ka) [Yenghi-ka _____ manna-ss-ta-ko]
 Cheli-nom (Sumi-nom) Y-nom meet-pst-decl-comp
 sayngkakhay-ss-ta-ko] malhay-ss-eyo] Tongswu-lul
 think-pst-decl-comp say-pst-decl T-acc

b.

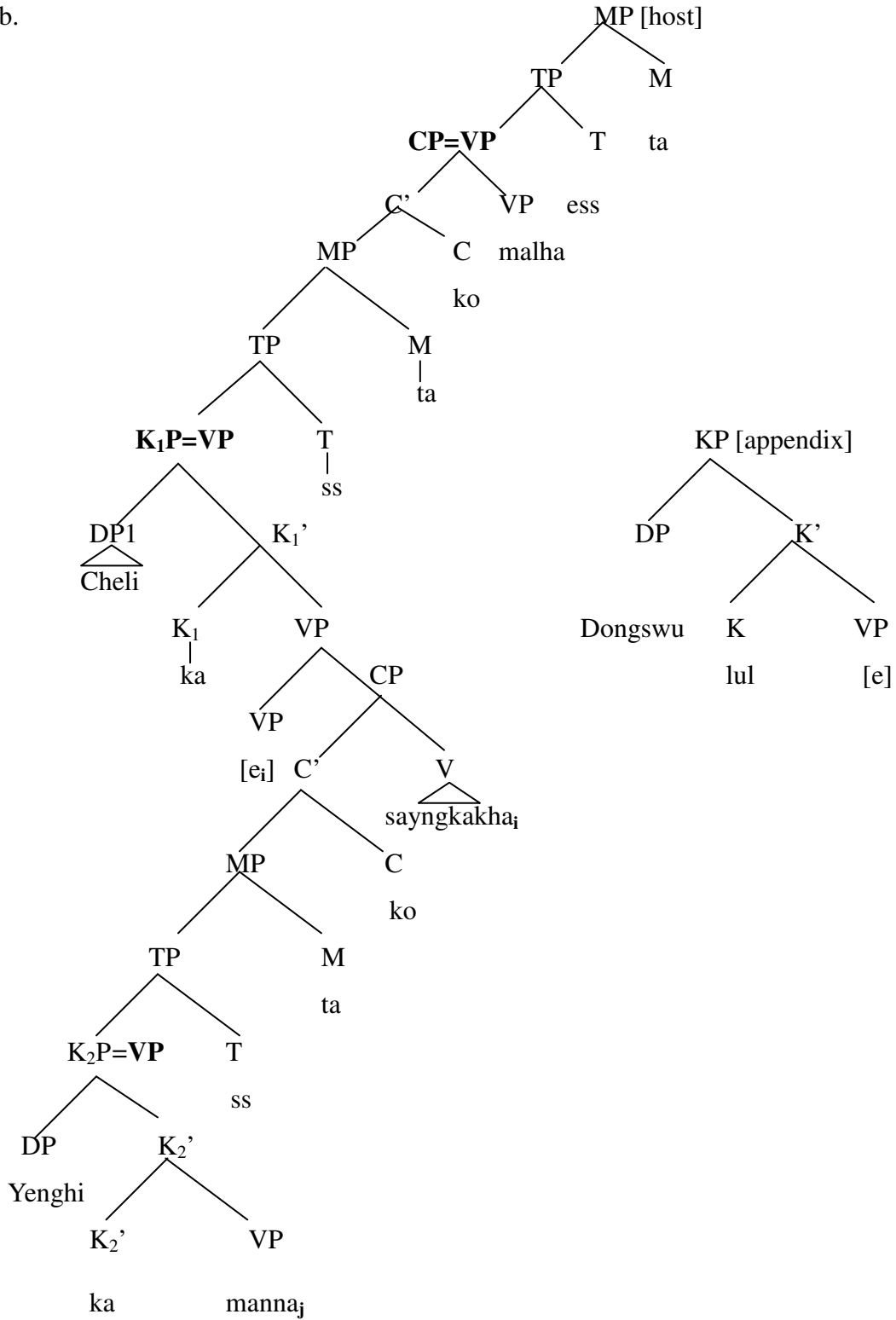

As illustrated in (131b), for the appendix to get interpreted, it has to cross three VPs, which is

impossible, hence the total ungrammaticality.

The same is observed in (132) as well; even though the gap is within a sentential subject, when it is embedded in another clause, the acceptability severely degraded.

(132)a. *[[Nwukunka-ka ____ yel-un-kes]-i hwaksilha-ta]-ko
who-nom ____ open-rel-NM-nom be.certain-decl-comp
Yenghi-ka malhay-ss-ta, kumko-lul
Y-nom say-pst-decl safe-acc

b.

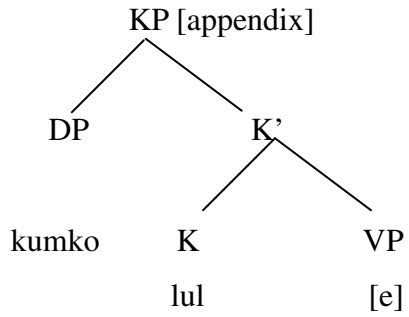
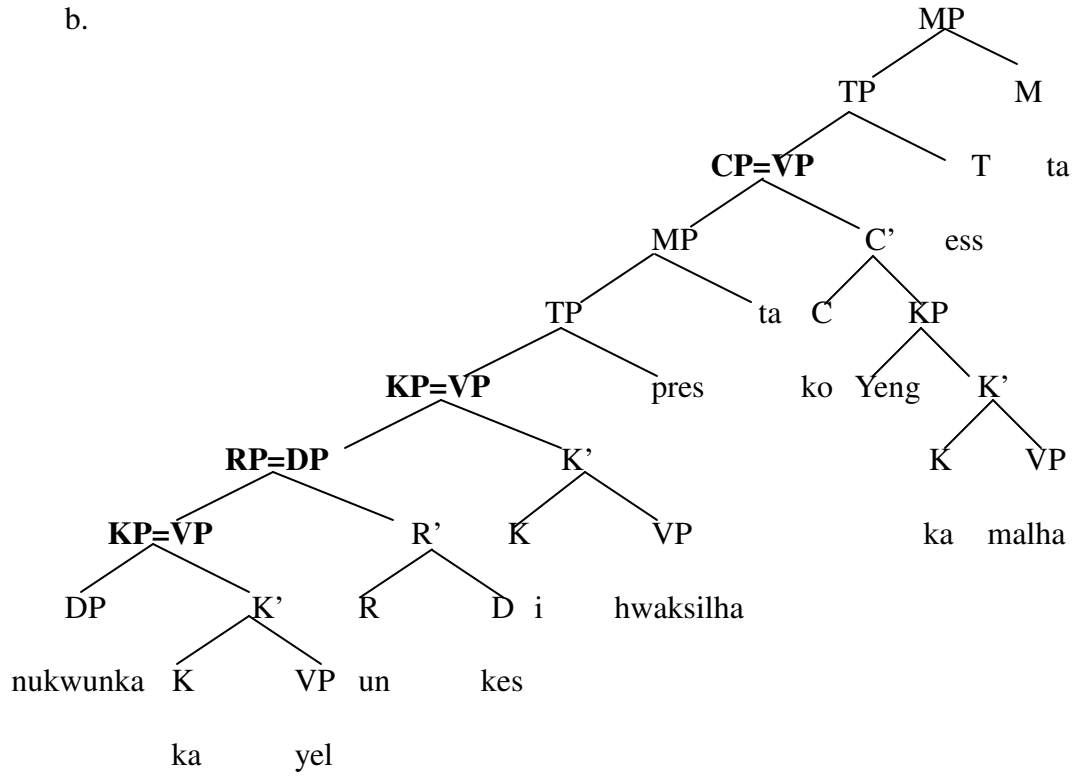

Table 2 is thus based on the observations so far, which is organized according to the degree of embedding.

Table 3. Degree of embedding

<i>The interpretive spot in the host</i>	<i>Process</i>	<i>result</i>
Sentential Subject or Complement Clause	Crossing two VPs	√
Complex NP Clause	Crossing VP/DP/VP	?*
Multiply/Deeply embedded Sentential Subject or Complement Clause	Crossing VP/VP/VP	*

If we assume “subjacency” is the constraint responsible for the linking between the appendix and the gaps as in the movement analyses, example (130) should be worse than (131) since (130) violates CNPC. However, observation (summarized as Table 2) shows that sentences such as (131) are worse than (130). Thus, I propose that the subjacency (Island) constraint³² is not relevant here and I instead provide a performance-based account (Hofmeister and Sag 2007), not competence-based theory such as subjacency since the proposed analysis posits the appendix as a base-generated one, not as a moved element from the host clause. Specifically, I attribute the low acceptability of (131) to processing difficulty. That is, when the appendix in (131) searches for the interpretive spot in the host clause, it goes too deeply into an embedded clause. That is, the overt predicate the null predicate should be unified with is embedded too deeply to be accessible. This account is consistent with the claim that processing difficulty can make grammatical sentences even unacceptable (Bever 1970; Chomsky & Miller 1963; Fanselow & Frisch 2006;

³² It has long been pointed out that there are counterexamples to island constraints and a gradedness (or ‘gradiance’) in the data that remain unexplained by standard island theories. Problematic data with Island Constraints have been reported by many researchers. Paul Deane (1991) especially showed various exceptions to complex NP constraint and proposed that island constraints are not abstract conditions on structures and transformation, and rather reflect “general cognitive processing”. Specifically, extraction requires paying simultaneous attention to two portions of a sentence and island violations occur when other parts of the sentence structure divert the limited resource of attention.

Osterhout, Holcomb & Swinney 1994 among others). This type of explanation can account for variation/gradience of acceptability as in (129-131) (See Table 2) and further explain processing differences in sentences that do not violate any proposed grammatical constraint. (Hofmeister and Sag 2007).

Hawkins (2004) proposed (132) as a clause-embedding hierarchy for accessibility of gaps.

(132) infinitival (VP) complement > finite (S) complement > S within a complex NP

He suggests that an infinitival complement involves fewer terminal elements for processing than a finite complement and a correspondingly smaller Filler Gap Dependency (FGD).

These differences in FGD sizes motivate the ranking above. Specifically, there are more nodes to process down the hierarchy, and these additional nodes involve phonological, morphological, lexical, syntactic, and semantic processing operations that apply simultaneously with gap processing.

In line with Hawkins (2004), we also propose that crossing VP, DP, VP involves fewer terminal elements for processing than crossing VP, VP, VP and these differences motivate the ranking in table 2 above. (cf. Hawkins 2004 for filler-gap dependency in relative clause) As the table shows, there are more nodes to process down the hierarchy, and these additional nodes involve phonological, morphological, lexical, syntactic, and semantic processing operations, which makes sentences less and less acceptable.

Note, however, the less acceptable RD constructions (130-131) improve³³ when the gap is realized as a full-fledged NP in the host clause as illustrated in (133-134).

³³ This should be a problem for theories that derive the appendix by movement/deletion in the second clause. In such theories, whether or not there is a full XP within the Host should not matter for the locality of the appendix.

(133) Cheli-ka [Suni-ka T-lul coaha-n-ta]-nun somwun-ul
 C-nom S-nom T-lul like-pres-decl-Rel rumor-acc
 tul-ess-ta, T-lul
 hear-pst-decl T-acc

‘Cheli heard the rumor that Suni likes T.’

(134)?? Cheli-ka (Sumi-ka) Yenghi-ka Tongswu-lul manna-ss-ta-ko
 Cheli-nom (Sumi-nom) Y-nom Tongswu-acc meet-pst-decl-comp
 sayngkakhay-ss-ta-ko malhay-ss-eyo, Tongswu-lul
 think-pst-decl-comp say-pst-decl T-acc

This effect is similar to the fact that English gaps in complex NPs can sometimes be rescued by resumptive pronouns as shown in the well-known example (135); the unacceptable (135a) is rescued by the resumptive pronoun in (135b).

(135)* a. I met the woman_i [who_i I had almost forgotten the fact that you once introduced me to
 ___]]
^{ok} b. I met the woman_i [who_i I had almost forgotten the fact that you once introduced me to
 her_i]]

As put by Hawkins (2004), a pronoun in situ is easier to process than a gap, since its lexical relation with the subcategorizer can be processed locally. In a similar vein, an overtly-realized phrase in the host clause can be processed locally and helps the appendix find the interpretive spot more easily.

Finally, here is a brief note on another issue on locality: the violation of the Right Roof Constraint. When we try to right-dislocate an element, obeying the RRC, the sentence becomes unacceptable, as we see in (136b). That is, the appendix is not allowed to occur between the embedded clause and the main clause. As mentioned before, if we assume the RD construction (represented as E) is a discourse unit, not a syntactic unit, the impossibility of RD occurring in an embedded context is well explained. However, let us consider if the proposed analysis provides a better explanation.

- (136) a. Cheli-nun Yenghi-ka Tongswu-lul manna-ss-ta-ko malhay-ss-ta
 C-Top Y-nom T-acc meet-pst-decl-comp say-pst-decl
 ‘Cheli said that Yenghi met Tongswu’
- b. *Cheli-nun Yenghi-ka manna-ss-ta-ko Tongswu-lul malhay-ss-ta
 C-Top Y-nom meet-pst-decl-comp T-acc say-pst-decl
 ‘Cheli said that Yenghi met Tongswu’

If we consider the structure (137) under the proposed system, it is understood that the base-generated clusters, CP and KaccP, combine first and then take Class 6 verb as their argument.

(137)

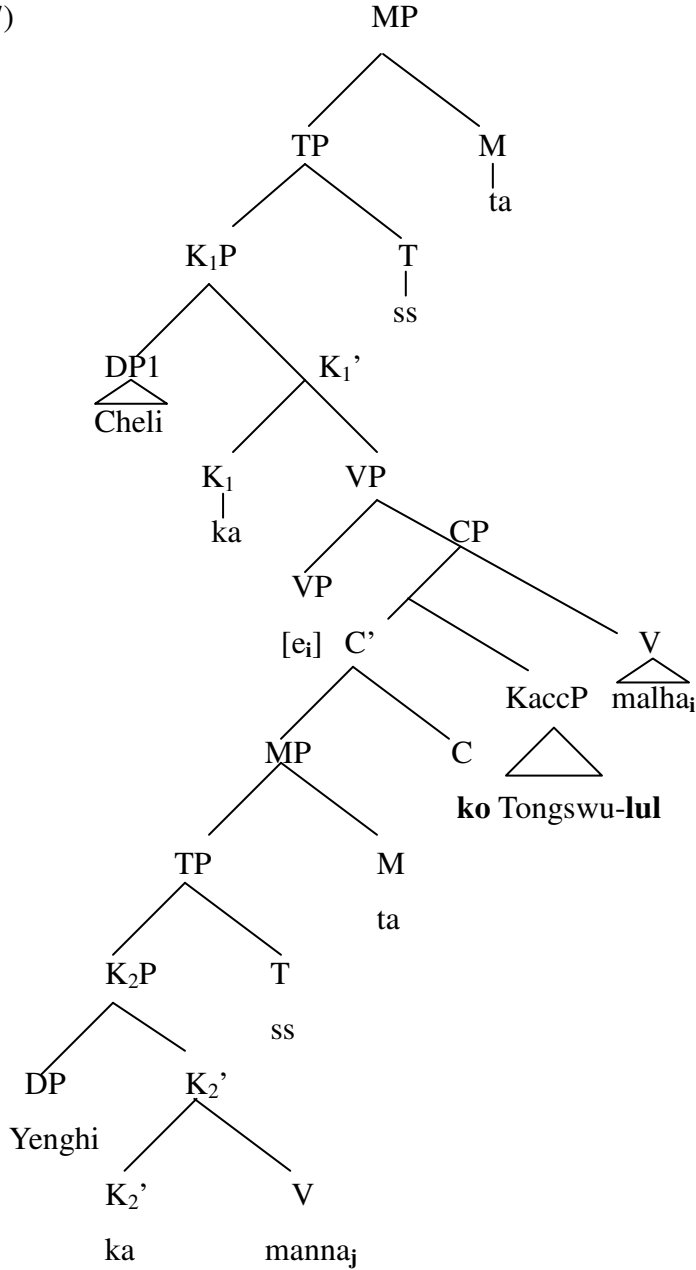

However, according to the verb classification (Previously introduced in chapter 2), they are not compatible, rendering this sentence to be out.

One might suggest the possibility that KaccP licenses a null predicate and does not combine with the preceding CP as in (138).

(138) Cheli-ka Yenghi-ka manna_i-ss-ta-ko [e_j] Tongswu-lul [e_i]
 C-nom Y-nom meet-pst-decl-comp T-acc
 malhay_j-ss-ta
 say-pst-decl
 ‘Cheli said that Yenghi met Tongswu.’

However, the null predicate cannot be anaphorically resolved within a sentence as it was with the null predicate [e_i] – since Korean is a verb final language, KPs expect an overt predicate to combine with them and should be cataphorically resolved in a sentence. The only exception to this is found when the null predicate the appendix licenses searches for an overt predicate in the host clause for it to be unified with. Since the appendix clause is in a clause separate from the host clause/sentence, the content of the null predicate can be anaphorically³⁴ resolved.

So far we have discussed issues on locality. We examined if RD constructions exhibit any constraints on movement, and it turned out that they do not necessarily.

4.6 Remarks on Adverbial or Adnominal Appendices: Heaviness and Closeness Constrains/Effects

As discussed above, an adverbial or an adnominal appendix is found in RD constructions as reintroduced in (139-140). The former licenses a null verbal predicate and the latter a null nominal predicate. This section discusses some constraints needed for the licensing and interpretation of those appendices.

³⁴ The other construction where the null predicate is resolved anaphorically is the case-marked fragment where the content of the null predicate the KP licenses is to be resolved. In this case as well, the overt predicate always comes before the fragment, so the null predicate is resolved anaphorically.

- (139) a. na-nun Cheli-lul manna-ss-e ecey
 I-Top Cheli-acc meet-pst-decl yesterday
- b. na-nun Cheli-lul manna-ss-e pi-ka ekswulo
 I-Top Cheli-acc meet-pst-decl rain-nom heavily
 nayli-te-n pam-ey
 come.down-ret-rel night-at
- (140)?a. na-nun catongcha-lul sa-ss-e nalk-un
 I-top car-acc buy-pst-decl be.old-rel
- b. Cheli-nun catongcha-lul sa-ss-e Toyota-ka mantu-n
 C-Top car-acc buy-Pst-decl T-nom make-REL

Let us compare examples with an adverbial appendix as in (139) with those with an adnominal appendix as in (140). Unlike adverbial appendices, there is some heaviness requirement with adnominal appendices. That is, as shown by the contrast in (140a and 140b), the acceptability improves when the adnominal appendix is “heavy”, which I call ‘heaviness constraints on adnominal appendices’.

On the other hand, in regard to embedded adjuncts (both adverbials and adnominals) as appendices, J-H Lee (2009) argues that embedded adjuncts are completely out when they are RDed as in (141a), while they are acceptable³⁵ when they are RDed together with one of the arguments of the embedded predicate as in (141b).

³⁵ Though J-H Lee 2009 was silent about the reason of this improvement, it is conjectured that the acceptability improves because the RD-ed case-marked argument provides some cues to finding the clause with respect to which the appendices are interpreted. Specifically, in (141b), the appendices should be construed with the embedded clause because the case-marked NP ‘chayk-ul’ is not compatible with the matrix clause predicate, considering verb classification proposed in this thesis.

(141)*a. Yenghi-nun Cheli-ka ___ chayk-ul ilk-ess-ta-ko
 Y-Top C-nom book-acc read-pst-decl-comp
 malhay-ss-ta yelsimhi
 say-pst-decl hard
 ‘Yenghi said that Cheli said the book hard.’

ok b³⁶. Yenghi-nun Cheli-ka ___ ilk-ess-ta-ko malhay-ss-ta
 Y-Top C-nom read-pst-decl-comp say-pst-decl
 yelsimhi chayk-ul
 hard book-acc
 ‘Yenghi said that Cheli said the book hard.’

However, embedded adjuncts, even without an embedded argument accompanied, are not completely out when they are RDed, though they are harder to get right-dislocated than matrix adjuncts due to “closeness effects”. Specifically, they can be successfully construed with the embedded predicates, as shown in (142-143). In fact, in this case, the RD-ed adjunct must be related to the embedded predicate, not to the matrix predicate, as evidenced by the fact that the adjunct *nayil-imyen* ‘tomorrow’ is not semantically compatible with *malhay-ss-ta* ‘said’.

³⁶ However, even if the adjunct is RDed together with one of the arguments of the embedded predicate, if the RDed argument can also be regarded as the argument of the matrix predicate as in (i), the sentence becomes ambiguous. Specifically, it has not only the reading where the appendices are related to the embedded clause as in (a) but also the reading where the appendices are related to the matrix clause as in (b).

- (i) Yenghi-nun Cheli-ka ponay-ss-ta-ko malhay-ss-ta
 Y-Top C-nom send-pst-decl-comp say-pst-decl
 ecey Suni-eykey
 yesterday Suni-dat
 a. ‘Yenghi said that Cheli sent (sth) to Suni yesterday.’
 b. ‘Yesterday Yenghi said to Suni that Cheli sent (sth) (to someone).’

(142) ^{ok} Yenghi-nun Cheli-ka ___ ku pap-ul mek-ul ke-la-ko
 Y-Top C-nom the meal-acc eat-conjec-decl-comp
 malhay-ss-e nayil-imyen [e]
 say-pst-decl tomorrow

‘Yenghi said that Cheli would eat the meal tomorrow.’

I propose that the first candidate for co-indexation/interpretation of [e] is always the closest predicate to the adverb/case-marked NP (that is, the matrix predicate). If the adjunct and the matrix predicate that the null predicate is unified with are semantically compatible, the interpretation process is completed, rendering [e] to be co-indexed with the matrix predicate. However, if they are not compatible as in (142) (* nayil-imyen ... malhay-ss-ta), the next closest candidate (mek-ul ke-la-ko) is considered for co-indexation /interpretation. Now, the adjunct and the second candidate, the embedded predicate, are semantically compatible, so the null predicate is co-indexed with the embedded predicate.

Likewise, syntactic compatibility also matters in co-indexing the null predicate with the overt one. The appendix ‘ecey Suni-hanthey’ in (143) is construed with both the embedded and the matrix predicate because they both are syntactically compatible.

(143) Yenghi-nun Cheli-ka ku senmwul-ul ponay-ss-ta-ko malhay-ss-e
 Y-Top C-nom the present-acc send-pst-decl-comp say-pst-decl
 ecey Suni-hanthey
 yesterday S-dat

By contrast, the appendix ‘ecey Suni-lul’ in (144) fails to be construed with the matrix predicate due to case mismatch (syntactic incompatibility), so it is finally co-indexed with the next available candidate -- the embedded predicate.

- (144) Yenghi-nun Cheli-ka manna-ss-ta-ko malhay-ss-ta ecey Suni-lul
 Y-Top C-nom meet-pst-decl-comp say-pst-decl yesterday S-acc
 ‘Yenghi said that yesterday Cheli met Suni.’

In similar respects, the following contrast exhibited by an adnominal appendix in terms of co-indexation/interpretation also confirms the above generalizations – the closeness effects in the interpretation of adjunct appendices. That is, the null element [e] that the NP adjuncts license prefers the closer overt NP for its co-indexation/unification, as exemplified in (145-146). (Examples modified from J-H Lee 2009) Specifically, the adnominal appendix ‘nemwu hwalyeha-ko alumtawu-n’ in (145) licenses a null noun, which is unified with the closest NP – *keli* ‘street’, predicting the intended meaning correctly. On the other hand, the null noun licensed by the adnominal appendix ‘nemwu hwalyeha-ko alumtawu-n’ in (146) is unified with the closest NP – *sonye* ‘girl’, yielding the intended meaning without fail.

- (145) na-nun sonye-lul keli-eyse manna-ss-e
 I-Top girl-acc street-in meet-pst-decl
nemwu hwalyeha-ko alumtawu-n [e]
 very be.fantastic-conj be.beautiful-REL
 ‘I met a girl on the street which was very fantastic and beautiful.’

(146) na-nun keli-eyse sonye-lul manna-ss-e
 I-Top street-in girl-acc meet-pst-decl
nemwu hwalyeha-ko alumtawu-n [e]
 very be.fantastic-conj be.beautiful-REL
 ‘I met a very fantastic and beautiful girl on the street.’

This closeness effects are consistent with/forced by the condition proposed in chapters above, which stated that [e] should be licensed as sparingly as possible and “resolved as soon as possible throughout derivation”. So, when the null element [e] looks back to the Host, searching for an overt predicate or noun for it to be unified with, it takes the closest overt Predicate/NP candidate, as long as they are semantically and syntactically compatible, by which it finally obtains the contents of the null element.

4.7 NPI and Wh-Phrase Appendices

In this subsection, I will discuss some issues associated with RD constructions with appendixes like NPIs or WH phrases. As these constructions behave differently than the phrases discussed above, they are treated separately here. Let us first consider the examples with NPIs. As pointed out by Takita (2008), the *pro* analysis faces problems as it allows the overt pronoun to fill in the *pro* (gap) position, which is ungrammatical as indicated in (147b).

(147) a. na-nun ilk-ci anh-ass-ta, amwukesto
 I-Top read-Neg-Pst-decl anything

* b. na-nun	kukes-ul	ilk-ci anh-ass-ta,	amwukesto
I-Top	it-acc	read-Neg-Pst-decl	anything
c. na-nun	amwukesto	ilk-ci anh-ass-ta,	amwukesto
I-Top	anything	read-Neg-Pst-decl	anything

The unacceptability of (147b), however, is accounted for under the ICCA. Specifically, once the predicate has been reconstructed in the appendix clause in (147b), a semantic mismatch arises between the host clause and the appendix clause. That is, the host clause *kukes-ul ilk-ci anh-ass-ta* ‘(I) did not read it’ does not have the same meaning that the appendix clause *amwukes-to ilk-ci anh-ass-ta* ‘(I) did not read anything’ has. Of course, a full-fledged overt noun can fill in the position as in (147c) as it preserves the original meaning of the sentence.

The present system accounts for sentences with quantifier phrases as in (148) in a similar fashion. After the reconstruction of the predicate in the appendix clause in (148b), a semantic mismatch arises between the host clause *kukes-ul mek-ci anh-ass-ta* ‘(I) did not eat it’ and the appendix clause *mwuesinka-lul mek-ci anh-ass-ta* ‘(I) did not eat anything.’

(148) a. na-nun	ilk-ess-ta,	mwuesinka-lul	
I-Top	read-pst-decl	something-acc	
* b. na-nun	kukes-lul	ilk-ess-ta,	mwuesinka-lul
I-Top	it-acc	read-pst-decl	something-acc
c. na-nun	mwuesinka-lul	ilk-ess-ta,	mwuesinka-lul
I-Top	something-acc	read-pst-decl	something-acc

Right-Dislocated Wh-phrases behave differently than those with other regular RD-ed phrases. As we have seen above, non-wh RD-ed phrases can be overtly realized as a full XP in the host clause without significant meaning change. However, the example in (149a) is ambiguous, while (149b) is not.

(149) a. *ne-nun mwues-ul po-ass-ni?*

You-Top what-acc see-pst-Q

‘Did you see something?’

‘What did you see?’

b. *ne-nun po-ass-ni mwues-ul?*

You-Top see-pst-Q what/somehting-acc

‘Did you see something?’

c. *ne-nun mwues-ul po-ass-ni, mwues-ul?*

You-Top what-acc see-pst-Q what-acc

‘Did you see something, something?’

‘What did you see, what?’

The ambiguity comes from the fact that *mwues* ‘what’ has two meanings ‘what’ and ‘something’, which determines what kind of Q-marker it is. When ‘mwues’ has the ‘what’ meaning, the Q-marker is wh-Q, while it is non-wh, yes/no-Q when ‘mwues’ has the ‘something’ meaning. For this reason, though syntactically not different from other RD constructions, RD with a wh-phrase as an appendix behaves differently when the gap is overtly realized in the host.

Now, let us see how the proposed analysis accounts for this. First, (149a) is ambiguous as

‘mwues’ is associated with two denotations, rendering there to be possibly two Q-markers. However, in (149b), there is no wh-phrase in the host, so the Q-marker is unambiguously yes/no-Q. So, when the predicate in (149b) is reconstructed, the reconstructed Q is yes/no Q, so the appendix gets the yes/no interrogative interpretation. That is, (149b) has only the reading ‘Did you see something?’. Thus, the fact that (149c) has both wh and yes/no Q readings supports this account.

Likewise, *nukwu* ‘who’ has two meanings, ‘who’ and ‘someone’, and the choice between the two determines what Q-marker is involved. When ‘nukwu’ denotes ‘who’, the Q-marker is wh-Q, while it is yes/no-Q when ‘nwuku’ has the meaning ‘someone’. Relevant examples follow (150a-c).

(150) a. ne-nun nwukwu-lul po-ass-ni?

 You-Top who-acc see-pst-Q

 ‘Did you see someone?’

 ‘Who did you see?’

 b. ne-nun po-ass-ni, nwukwu-lul?

 You-Top see-pst-Q who/someone-acc

 ‘Did you see someone?’

 c. ne-nun nwukwu-lul po-ass-ni, nwukwu-lul?

 You-Top who-acc see-pst-Q who-acc

 ‘Did you see someone, someone?’

 ‘Who did you see, who?’

(150a) is ambiguous because ‘nwuku’ denotes either ‘who’ or ‘someone’. However, in (111b), there is no *wh*-phrase in the host, so the Q-marker is unambiguously yes/no-Q. So, when the predicate is reconstructed in (150b), the reconstructed Q is yes/no Q, so the appendix gets the yes/no interrogative interpretation only. That is, (150b) has the reading ‘Did you see someone?’ only. The fact that (150c) has both the *wh* and the yes/no Q readings confirms this account. Exactly the same account can be made for examples with other *wh*-phrases such as *eti* ‘where’, as in (151a-c).

- (151) a. ne-nun eti-lo ka-ss-ni?
 You-Top where-to go-pst-Q
 ‘Did you go somewhere?’
 ‘Where did you go?’
- b. ne-nun ka-ss-ni, eti-lo?
 You-Top go-pst-Q where/somewhere-to
 ‘Did you go somewhere?’
- c. ne-nun eti-lo ka-ss-ni, eti-lo?
 You-Top where-to go-pst-Q where-to
 ‘Did you go somewhere, somewhere?’
 ‘Where did you go, where?’

Finally, as we have seen in 4.1 above, even when a sentence is composed only of a subject and a (di)transitive verb only or when a sentence is missing a subject, it is still an acceptable sentence, and we do not need to posit an empty slot (trace or *pro*) for it. So, that an RD construction lacks a

subject or an object does not necessarily mean that the appendix should fill the gap, which is exemplified by the answer parts with an RD in (152-153).

(152)Q: yeki iss-ess-te-n chayk-i eti-lo salaci-ess-ni?
here be-pst-retro-REL book-nom where-to disappear-pst-Q
'Where is the book that was put here?'

A: nay-ka Yenghi-eykey cwu-ess-e ecey
I-nom Y-dat give-pst-decl yesterday
'I gave Yenghi (the book) yesterday.'

(153)Q: Ne-nun choykuneY Yenghi-lul po-n cek-i iss-ni?
You-Top recently Y-acc see-REL time-nom exist-Q
'Have you seen Yenghi recently?'

A: Na-nun manna-ss-e ecey
I-Top meet-pst-deco yesterday
'I met (her) yesterday.'

5. Summary and Case-Drop in RD

In this chapter, I have presented various empirical phenomena associated with right-dislocations in Korean and proposed that a bi-clausal, base-generation analysis under the Incremental C-selectional Combinatoric Analysis is on the right track. I also showed, by presenting RDs with adnominal modifiers or determiners as an appendix, that the proposed analysis has advantages over the other kinds of movement analyses. Adnominal modifiers or determiners can not be accounted for under a movement analysis under the common assumption that movement targets a

constituent. I also showed some constraints ‘heaviness’ and ‘closeness’ on the formation and interpretation of the adnominal and adverbial appendices. The analysis also explained RDs with appendices such as NPIs, quantifiers or wh-phrases. I finally discussed that there are indeed constraints on how deeply the predicate in the Host can be embedded (associated with the appendix) to be co-indexed with the null predicate in the appendix and showed that the constraint is not identical to subjacency.

Before closing this Chapter, we have to consider how to handle right-dislocations where the appendix is not case-marked as exemplified in the answer parts of (154-155). As the proposal is bi-clausal analysis where the case-marked appendix, like a fragment, licenses a null predicate, the absence of the case-marker in the appendix seems to pose a problem with the proposed analysis.

(154) Q: nwuka ku ppang-ul mek-ess-ni?

Who the bread-acc eat-pst-Q

‘Who ate the bread?’

A: Cheli-ka mek-ess-e ku ppang

C-nom eat-pst-decl the bread

‘Cheli ate the bread.’

(155) Q: nwuka Yenghi-lul manna-ss-ni?

Who Y-acc meet-pst-Q

‘Who met Yenghi?’

A: Cheli-ka manna-ss-e Yenghi

C-nom meet-pst-decl Yenghi

‘Cheli met Yenghi.’

In previous discussion, the case-marked appendix is analyzed in a fashion similar to the case-marked fragment, in the sense that they license a null predicate whose contents are determined anaphorically, unlike other null predicates occurring within a sentence.

I suspect that the case less appendix is pragmatically licensed in the way in which a case less fragment is licensed (Y-J Choi 2008 for a discussion on case less Fragments in Korean, Merchant 2007 for pragmatic ellipsis), but this will be pursued for future studies.

Chapter 5:

Conclusion

In this dissertation, I proposed a Incremental C-selectional Combinatoric Analysis in which feature specifications are assigned to combinatoric/dependent markers. The basic idea is that case-marked NPs combine with each other (Dependent Marking Parameter of Y-J Choi 2007) and select a compatible predicate based on case arrays and verb classifications. As a case-marked NP selects a predicate, it licenses a null predicate when there is no overt predicate with which it can combine. I first presented two types of nominal coordinations in Korean that are differentiated by the presence or absence of a case-marker in the initial conjunct NP. This marking difference triggers prosodic, semantic and syntactic differences between the two constructions. I also discussed how to determine the contents of null predicates when constructions contain them as is the case of RNR/CoRNR constructions. The content of a null predicate in the initial conjunct is resolved when a compatible, overt predicate is encountered in the final conjunct. Finally, I examined a construction involving both null arguments (in most cases) and null predicates --Right-Dislocations (RD). The construction by itself is given a bi-clausal analysis where the host clause involves a null argument (in most cases), and the appendix involves a null predicate. The structure of a Host clause is similar to that of argument ellipsis constructions. That is, an ellipsis site is not represented by any structural marking. The appendix part is proposed to involve a null predicate, which is locally licensed by case-markers or other combinatoric markers (i.e., dependent markers called by Y-J Choi 2008). Interestingly, the content of a null predicate in an appendix clause is resolved differently than that of a null predicate in RNR constructions. Specifically, a null predicate, when licensed in the middle of a

sentence as in RNR, is resolved cataphorically due to the fact that (overt) verbs appear in the sentence-final position (i.e., the fact that Korean is a verb-final language). However, a null predicate in an appendix clause is resolved anaphorically, reflecting the fact that an appendix does not belong to the same clause that a Host belongs to but comprises a clause that is separate from the host clause.

Before we close, let us consider how constructions without case-marking can be accounted for under the Incremental C-selectional Combinatoric Analysis where case-markers play a crucial role. I will propose that sentences with no case markers are asyntactically formed. Before discussing the relevant examples, let us first consider (1) in which all case-markers are overtly realized. The feature specification of the nominative marker [1] shows that it takes Verb Classes 1-7 and the feature specification of the accusative marker [2] shows that it only takes Verb Classes 2 and 4. So, both ‘co-tag’ and they grammatically take Verb Class 2 ‘mek-ta’ as their argument.

- (1) Yenghi-**ka** sakwa-**lul** mek-ess-e
 Y-nom apple-acc eat-pst-decl
 ‘Yenghi ate an apple.’

[1] Nominative Case-marker (K_{NOM})

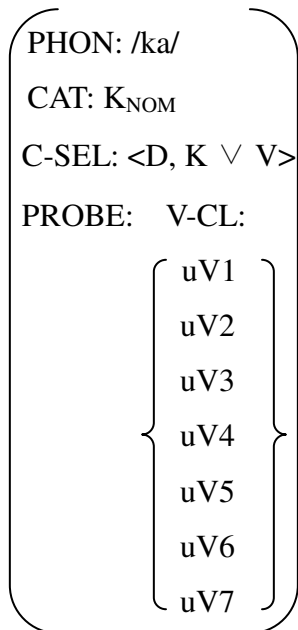

[2] Accusative Case-marker (K_{ACC})

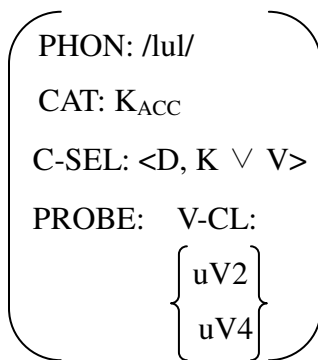

In a similar fashion, in a sentence that has no accusative case-marker, the feature specification of the nominative marker shows that the nominative-marked NP takes Verb Class 1-7 as shown in (2). However, the object NP ‘sakwa’ does not carry any case-markings, and does not impose any restrictions on the types of verbs that follow. So, all classes of verbs can follow and, in this case, Verb Class 2 happens to come, which does not cause ungrammaticality due to the fact that no incompatibility or semantic anomaly arises in this sentence.

(2) Yenghi-**ka** sakwa-∅ mek-ess-e
 Y-nom apple eat-pst-decl
 ‘Yenghi ate an apple.’

The proposed system further predicts that (3) is unacceptable. Similar to the previous example, the feature specification of the nominative marker shows that it takes verb classes 1-7. However, the object NP ‘sakwa’ carries no case-markings, so imposes no restrictions on the types of verbs that follow. Thus, all classes of verbs can follow and, in this case, verb class 1 happens to come, which does not cause incompatibility according to the reasoning so far. However, there is a semantic anomaly between the NPs and the verb ‘wus-ta’, so this sentence, though grammatical under the system, is uninterpretable and judged to be unacceptable.

(3) * Yenghi-**ka** sakwa-∅ wus-ess-e
 Y-nom apple laugh.at-pst-decl

Finally, let us consider how the current system can account for sentences like (4) where there are no case-markers at all; notice that neither the subject NP nor the object NP carries a case-marker. Basically, all classes of predicates follow these NPs as long as the predicates are two-place predicates or more. In this case, verb class 2 happens to come, which does not cause incompatibility according to the reasoning so far. So, this sentence is analyzed to be asyntactically formed and, since there is no semantic anomaly involved, it is interpretable and acceptable as well.

- (4) Yenghi-Ø sakwa-Ø mek-ess-e
 Y-nom apple eat-pst-decl
 ‘Yenghi ate an apple.’

Before we close, one direction for future research is to test the present analysis by applying it to the so-called multiple nominative constructions as in (5) and multiple accusative constructions as in (6).

- (5) Cheli-ka khi-ka anc-un khi-ka khu-ta
 C-nom height-nom sitting.height-nom be.tall-decl
- (6) Cheli-ka kwail-ul sakwa-lul Fuji-lul coaha-n-ta
 C-nom fruit-acc apple-acc Fuji-acc like-pres-decl

As shown in (5-6), Korean allows more than one nominative or accusative marked NPs and oftentimes a mix of both. We will have to see if those constructions are also built by the same cues of case markers or if there are other things involved in these constructions. I leave these for future research.

Finally, the proposed analysis gives some important implications to the debate on parsing in strict SOV languages. There are two competing views on parsing: One is a head-driven parsing view (Pritchett 1991, 1992) where the NPs remain unattached until the verb comes in, at which point the VP is projected and the NPs are integrated into the structure. The other is an incremental parsing view (Yamashita 1994, 1997; Kim 1999; Kamide & Mitchell 1999; Mazuka et al., 2002; Miyamoto & Takahashi 2002; Ueno & Kluender 2003; Shin 2006, etc.) where NPs

are immediately integrated into a partial structure that is built based on the available local information (i.e., case markers) even before the relevant verb arrives. The proposed system in this thesis is compatible with the evidence from what is known about parsing in strict SOV languages -- Incremental Parsing View. Even though grammar is process neutral, grammatical representation for languages like Korean is quite similar to parsing. The argument for the grammar being similar to parsing is not just the processing evidence – it is based on grammatical generalizations discussed in the thesis.

REFERENCES

- Abe, Jun. 1999. On Directionality of Movement: A Case of Japanese Right Dislocation. Ms. Nagoya University.
- Abbott, Barbara. 1976. Right Node Raising as a test for constituenthood. *Linguistic Inquiry* 7:639–642.
- Ahn, Hee-Don and Sungeun Cho. 2006b. Dual Analysis of Korean RNR. *Language Research* 25.
- An, Duk-Ho. 2007. Syntax at the PF Interface, University of Connecticut Dissertation
- Aoun, Joseph, Elabbas Benmamoun, and Dominique Sportiche. 1994. Agreement, Word Order, and Conjunction in Some Varieties of Arabic. *Linguistic Inquiry* 25, 195-220.
- Aoun, Joseph, Elabbas Benmamoun, and Dominique Sportiche. 1999. Further Remarks on First Conjunct Agreement. *Linguistic Inquiry* 30, 669-681.
- Bachrach, Asaf, and Roni Katzir. 2006. Right-node raising and delayed spellout. In Proceedings of Interphases
- Baker, B. 2007. Japanese adnominal postposing and an argument against movement. Senior Honors thesis, Department of East Asian Languages and Cultures, Ohio State University
- Baker, Mark C. 1996. *The polysynthesis parameter*. Oxford Studies in Comparative Syntax. New York: Oxford University Press
- Baker, Mark C. 2001a. The natures of nonconfigurationality. In Baltin, M. R. (ed.), *The Handbook of Contemporary Syntactic Theory*. Blackwell, Oxford. 407-438.
- Bošković, Željko. 1995. Participle movement and second position cliticization in Serbo-Croatian. *Lingua* 96, 245-266
- Bošković, Željko. 2005. On the locality of left branch extraction and the structure of NP. *Studia Linguistica* 59: 1-45
- Bouchard, D. 2001. The concept of ‘universal’ and the case of Japanese. *Lingua* 111: 247-277.
- Bresnan, Joan (ed) 1982. *The Mental Representation of Grammatical Relations*. Cambridge: The MIT Press.
- Carlson, Greg. 1987. Same and different: some consequences for syntax and semantics. *Linguistics and Philosophy* 10, 531-565.
- Choe, Hyon Sook. 1987. Successive-cyclic rightward movement in Korean. In S. Kuno et al. (ed.), *Harvard Studies in Korean Linguistics*, Vol. 2, 40-56.

- Choi, Youngju and James Yoon. 2006. Argument cluster coordination and constituency test (non)-conflict. Paper presented at the 38th meeting of the North East Linguistic Society (NELS 38). Oct 2007. Ottawa University, Canada
- Choi, Youngju. 2006. Base-generated right-dislocation. *Harvard Studies in Korean Linguistics* 11: 387-400.
- Choi, Youngju. 2007. *Dependent Marking Parameter: Coordination, Clefting, Fragments and Scrambling in Korean and Japanese*. UIUC Dissertation.
- Chomsky, Noam. 1995. *The Minimalist Program*. MIT Press.
- Chomsky, Noam and George A. Miller. 1963. Introduction to the formal analysis of natural languages. In Luce, R. D., Bush, R. R., and Galanter, E. (eds.), *Handbook of Mathematical Psychology*, Vol. 2, Wiley, New York, pp. 269–322.
- Chung, Daeho. 2004. Multiple Dominance Analysis of Right Node Raising Constructions. *Language Research* 40, 791-812.
- Chung, Daeho. 2008. On the Syntax of Non-final Predicate Consturction in Korean. Paper presented at the LSK Winter Conference
- Citko, Barbara. 2003. “ATB questions and the nature of merge”, in Kadowaki & Kawahara (eds.), *Proceedings of NELS 33*, GLSA, University of Massachusetts, Amherst
- Deane, Paul. 1991. A cognitive theory of island phenomena. *Cognitive Linguistics* 2 (1): 1-63.
- Dowty, David 1988. *Type Raising, Functional Composition and Non-Constituent Conjunction*. In R. Oehrle et al. Eds., *Categorial Grammars and Natural Language Structures*.
- Endo, Yoshio. 1996. Right dislocation. In M. Koizumi, M. Oishi, and U. Sauerland (eds.), *Formal Approaches to Japanese Linguistics 2*, MIT Working Papers in Linguistics 29, 1-20. Cambridge, Dept. of Linguistics, MIT.
- Fanselow, Gisbert, and Stefan Frisch. 2006. Effects of processing difficulty on judgments of acceptability. In *Gradience in grammar*, ed. by Gisbert Fanselow, Caroline Féry, Mattias Schlesewsky, and Ralf Vogel, 291-316. Oxford: Oxford University Press.
- Fukui, Naoki and Hiromu Sakai. 2003. Fukui, Naoki & Hiromu Sakai. 2003. The visibility guideline for functional categories: verb raising in Japanese and related issues. *Lingua* 113: 321-375
- Fukushima, Kazuhiko. 2003. Verb-raising and numeral classifiers in Japanese: Incompatible bedfellows. *Journal of East Asian Linguistics* 12: 313-347.

- Grosu, Alexander. 1976. A note on subject raising to object and right node raising. *Linguistic Inquiry* 7:642-645.
- Ha, Seungwan. 2006. An Ellipsis Account for Right Node Raising in Korean. *Paper presented at Workshops on Altaic in Formal Linguistics*. Moscow State University, Moscow, Russia.
- Ha, Seungwan. 2007. Ellipsis, Right Node Raising, and ATB Constructions. *Presented at the 30th annual colloquium of Generative Linguistics in the Old World*, University of Tromsø, Norway.
- Han, Chung-hye and Maribel Romero. 2004. Syntax of *Whether/Q...Or* Questions: Ellipsis Combined with Movement. *Natural Language & Linguistic Theory*, 22:3, 527-564.
- Haraguchi, S. 1973. Remarks on Right Dislocation in Japanese. Ms., MIT.
- Hartmann, Katharina. 2000. *Right Node Raising and Gapping: Interface Conditions on Prosodic Deletion*. John Benjamins Publishing Company, Philadelphia/Amsterdam.
- Hawkins, John A. 2004. *Efficiency and Complexity in Grammars*. Oxford: Oxford University.
- Hofmeister, P., I. A. Sag, N. Snider. 2007. "Empirical Investigations of Gradience in Syntactic Islands." 43rd Regional Meeting of the the Chicago Linguistic Society (CLS 43), Chicago.
- Kayne, Richard S. 1994. *The Antisymmetry of Syntax*, MIT Press, Cambridge, MA
- Kempson, R. & Meyer-Viol, W. & Gabbay, D. 2001. *Dynamic Syntax: The Flow of Language Understanding*. Blackwell.
- Kiaer, Jieun and Ruth Kempson. 2005. Pro-active Parsing of Korean Scrambling. In *Proceedings of the 24th West Coast Conference on Formal Linguistics 24*, 209-217. Somerville, MA: Cascadilla Proceedings Project.
- Kim, Soowon. 1999. Sloppy/strict identity, empty objects, and NP ellipsis. *Journal of East Asian Linguistics* 8.
- Kim, Y. 1999. The Effects of Case Marking Information on Korean Sentence Processing. *Language and Cognitive Processes* 14: 687-714.
- Kim, Yong-Ha. 2006. A case for Ellipsis in Korean: The Non-movement Multiple Object Construction. *Studies in Generative Grammar* 16(4). 737-772.
- Koga, Hiroki. 2000. *A grammar of case: The head of a semantic filler, but a nominative morpheme*. PhD Dissertation. University of Illinois at Urbana-Champaign.

- Koizumi, Masatoshi and Hiroyuki Ura (Eds.), *Formal Approaches to Japanese Linguistics 1, MIT Working Papers in Linguistics 24*, Department of Linguistics and Philosophy, MIT, pp. 211–230.
- Koizumi, Masatoshi. 2000. String vacuous overt verb raising. *Journal of East Asian Linguistics* 9: 227-285.
- Kuno, Ross, Erteschik-Shir (& Lappin), Lakoff, Chung, McCloskey, Engdahl, Allwood, Maling, Zaenen, Kroch, Szabolcsi, Zwarts, Deane, Goldberg, a.o.). Paul Deane 1991
- Kuroda, Sige-Yuki. 1965. Generative Studies in the Japanese Language. MIT Dissertation.
- Kuroda, Shige-Yuki. 1978. Case marking, canonical sentence patterns, and Counter Equi in Japanese (a preliminary survey). In J. Hinds and I. Howard (eds.), *Problems in Japanese Syntax and Semantics*. Tokyo: Kaitakusha. pp.30–51
- Kuroda, Shige-Yuki. 1992. *Japanese Syntax and Semantics*. Kluwer Academic Publication.
- Lee, Eun-ji. 2005. The Status of the Null Object in the VP Ellipsis Context, *Studies in Generative Grammar*, Volume 15, Number 4, 609-629.
- Lee, Chunghoon. 2009. Hankwuke hwupochwung kwumwun-uy kwoco (The Structure of Korean afterthought constructions), *Emun-yenkwu* 37:31-54.
- Levine, Robert D. 1985. Right Node (non-)raising. *Linguistic Inquiry* 16:492-497
- Mazuka, R., K. Itoh, & T. Kondo. 2002. Cost of Scrambling in Japanese Sentence Processing. *Sentence Processing in East Asian Languages*, ed. M. Nakayama. Stanford: CSLI.
- McCawley, James. 1982. Parentheticals and Discontinuous Constituent Structure. *Linguistic Inquiry*, 13:1, Winter.
- McCloskey, James. 1986. Inflection and conjunction in Modern Irish. *Natural Language & Linguistic Theory* 4:245–281.
- Merchant, Jason. 2001. *The syntax of silence*. Oxford: Oxford University Press.
- Merchant, Jason. 2007. Three Kinds of Ellipsis. Syntactic, Semantic, Pragmatic? Presented at the Semantics workshop, 4-5 Oct 2008, Rutgers
- Miyamoto, E. T., & S. Takahashi. 2002. Sources of Difficulty in Processing Scrambling in Japanese. *Sentence Processing in East Asian Languages*, ed. M. Nakayama. Stanford: CSLI.
- Murasugi, Keiko. 1991. Noun Phrases in Japanese and English: A Study in Syntax, Learnability and Acquisition. University of Connecticut Dissertation.

- Murayama, K. 1999. An Argument for Japanese Right Dislocation as a Feature driven movement. *Gengokagakukenyu* 5: 45-62.
- Nichols, Johanna. 1986. Head-marking and dependent-marking grammar. *Language* 62: 56-119.
- O'Grady, William. 1991. Categories and case: The sentence structure of Korean. Philadelphia: John Benjamins.
- O'Grady, William. 2002. Korean case: Extending the computational approach. *Korean Linguistics* 11, 29-51.
- Oku, S. 1998. *A Theory of Selection and Reconstruction in the Minimalist Perspective*. PhD dissertation, University of Connecticut.
- Osterhout, L., Holcomb, P. J., & Swinney D. A. 1994. Brain potentials elicited by garden-path sentences: Evidence of the application of verb information during parsing. *Journal of Experimental Psychology: Learning Memory and Cognition*, 20, 786-803.
- Park, Myung-Kwan. 2006. Morphological/inflectional Strict vs. Sloppy Identity in RNR Constructions: Towards a Midway Coordination Analysis, *Studies in Generative Grammar* 16(1), 175-191
- Park, Myung-Kwan. 2007. RNR in Korean as Right-Edge Coordination, *Studies in Generative Grammar* 17(1), 85-97
- Philips, Collin. 1996. Order and Structure. Doctoral Dissertation. MIT.
- Phillips, Collin. 2003. Linear Order and Constituency. *Linguistic Inquiry* 34.1: 37-90.
- Postal, Paul. 1974. *On Raising*. Cambridge, MA.: MIT Press
- Pritchett, B. L. 1991. Head Position and Parsing Ambiguity. *Journal of Psycholinguistic Research* 20: 251-270.
- Pritchett, B. 1992. Grammatical Competence and Parsing Performance. Chicago: The University of Chicago Press.
- Reinhart, T. 1983. *Anaphora and Semantic Interpretation*. London: Croom Helm.
- Ross, J. R. 1967. Constraints on variables in syntax. Doctoral Dissertation, MIT, Cambridge, MA.
- Ruth Kempson, Wilfried Meyer-Viol and Dov Gabbay. 2001. *Dynamic Syntax: The Flow of Language Understanding*, Blackwell
- Sabbagh, Joseph. 2007. Ordering and Linearizing Rightward Movement. *Natural Language and Linguistic Theory* 25, 349-401

- Saito, Mamoru. 1994. *Improper adjunction*. In *Formal approaches to Japanese Linguistics 1*, ed. by Masatoshi Koizumi and Hiroyuki Ura, 263–293.
- Saito, Mamoru. 2004. Japanese scrambling in a comparative perspective. In *Peripheries: Syntactic edges and their effects*, ed. by David Adger, Cecile de Cat, and George Tsoulas, 143–163. Dordrecht: Kluwer.
- Sells, Peter. 1995. Korean and Japanese Morphology from a Lexical Perspective. *Linguistic Inquiry* 26, 277-325.
- Sells, Peter. 1999. Japanese Postposing Involves No Movement. Presented at the meeting of the Linguistics Association of Great Britain, Lancaster, April 1998
- Shieber, Stuart. 1986. *An Introduction to Unification-based Approaches to Grammar*, Palo Alto, CA: Center for the Study of Language and Information. CSLI Lecture Notes 4.
- Shin, K. S. 2006. Korean Double Nominative Constructions. In *Japanese/Korean Linguistics 14*, ed. T. J. Vance & K. A. Jones. Stanford, CA: CSLI Publications.
- Simon, Mutsuko Endo. 1989. An Analysis of the Postposing Construction in Japanese. Doctoral dissertation, University of Michigan
- Sohn, Keun-Won. 2001. Deletion and Right Node Raising in Korean and English. *Studies in Generative Grammar* 11.2., 485-501.
- Steedman, Mark J. 1990. Gapping as Constituent Coordination, *Linguistics and philosophy* 13, 207–263.
- Steedman, Mark J. 1985. Dependency and Coordination in the Grammar of Dutch and English, *Language* 61(3), (in press).
- Takano, Y.-S. 2003. ‘Nominative Objects as Proleptic Objects’, *NLLT* 21, 779-834.
- Takano, Yuji. 2002. Surprising constituents. *Journal of East Asian Linguistics* 11: 243-301.
- Takita, Kensuke. 2008. “Argument Ellipsis in Japanese Right Dislocation,” *Japanese/Korean Linguistics 18.*, Stanford, CA: CSLI Publications
- Tanaka, Hidekazu. 2001. Right-Dislocation as Scrambling. *Journal of Linguistics* 37: 551-. 579.
- Ueno, M. & R. Kluender. 2003. Event-related Brain Indices of Japanese Scrambling. *Brain and Language* 86: 243-271.
- Vicente, Luis and Mark de Vos. 2005. Coordination under RNR (CoRNR): at the intersection of Syntax and PF, Presented at the WCCFL 24, 18-20, March 2005. Simon Fraser University, Vancouver.

- Whitman, John. 1998. Kayne 1994, p.143, fn.3, in G. Alexandrova ed., *Challenges of Minimalism*, John Benjamins.
- Wilder, Chris. 1997. English Finite Auxiliaries in Syntax and Phonology. In *Clitics, Pronouns and Movement*, eds. James R Black and Virginia Motapanyane. Amsterdam/Philadelphia: John Benjamins.
- Wilder, Chris. 1999. Right Node Raising and the LCA. In *The Proceedings of WCCFL 18* eds. Sonya Bird, Andrew Carnie, Jason D. Haugen, and Peter Norquest, 586-598. Somerville, Mass.: Cascadilla Press
- Yamashita, H. 1994. Processing of Japanese and Korean. Unpublished doctoral dissertation, Columbus, OH: Ohio State University.
- Yamashita, H. 1997. The Effects of Word-Order and Case Marking Information on the Processing of Japanese. *Journal of Psycholinguistic Research* 26: 163–188.
- Yamashita, H. 2008. More than One, but at Most Two Thematic –*wa* in Japanese: An argument for the Bi-sentential Analysis of Right Dislocation. Paper presented at the 18th Japanese/Korean Linguistics Conference, CUNY, November 2008.
- Yoon, James and Wooseung Lee. 2005. Conjunction reduction and its consequences for noun phrase morphosyntax in Korean. In *Proceedings of the 24th West Coast Conference on Formal Linguistics*, 379-387. Somerville, MA: Cascadilla Proceedings Project.
- Yu-Cho, Young-Mee and Peter Sells. 1995. A Lexical Account of Inflectional Suffixes in Korean, *Journal of East Asian Linguistics* 4: 119-174.