

2021

Opportunistic Maintenance Strategy of a Heave Compensation System for Expected Performance Degradation

Chao Zhang

Yujie Qian

Hongyan Dui

Shaoping Wang

Rentong Chen

See next page for additional authors

Follow this and additional works at: https://digitalcommons.odu.edu/engtech_fac_pubs



Part of the [Hydraulic Engineering Commons](#), [Industrial Technology Commons](#), and the [Ocean Engineering Commons](#)

Original Publication Citation

Zhang, C., Qian, Y. J., Dui, H. Y., Wang, S. P., Chen, R. T., & Tomovic, M. M. (2021). Opportunistic maintenance strategy of a heave compensation system for expected performance degradation. *Eksploracja i Niezawodność - Maintenance and Reliability*, 23(3), 512-521. <https://doi.org/10.17531/ein.2021.3.12>

This Article is brought to you for free and open access by the Engineering Technology at ODU Digital Commons. It has been accepted for inclusion in Engineering Technology Faculty Publications by an authorized administrator of ODU Digital Commons. For more information, please contact digitalcommons@odu.edu.

Authors

Chao Zhang, Yujie Qian, Hongyan Dui, Shaoping Wang, Rentong Chen, and Mileta M. Tomovic

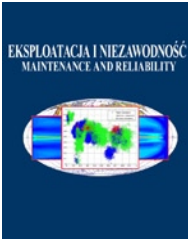

Article citation info:

Zhang C, Qian Y, Dui H, Wang S, Chen R, Tomovic MM. Opportunistic maintenance strategy of a Heave Compensation System for expected performance degradation. *Eksploracja i Niezawodność – Maintenance and Reliability* 2021; 23 (3): 512–521, <http://doi.org/10.17531/ein.2021.3.12>.

Opportunistic maintenance strategy of a Heave Compensation System for expected performance degradation

Indexed by:



Chao Zhang^{a,b,c,*}, Yujie Qian^{a,c}, Hongyan Dui^d, Shaoping Wang^{a,c}, Rentong Chen^a, Mileta M. Tomovic^e

^aSchool of Automation Science and Electrical Engineering, Beihang University, Beijing 100083, China

^bResearch Institute for Frontier Science, Beihang University, Beijing 100191, China

^cNingbo Institute of Technology, Beihang University, Ningbo 315800, China

^dSchool of Management Engineering, Zhengzhou University, Zhengzhou 450001, China

^eEngineering Technology Department, Old Dominion University, Norfolk, VA 23529 USA

Highlights

- An opportunity maintenance model is proposed for semi-active heave compensation system.
- The importance theory is applied into the opportunistic maintenance model.
- The joint integrated importance measure between different components is analyzed.
- The JIIM is used as the basis for preventive maintenance of components.
- The effectiveness of JIIM-based OM in terms of expected system performance is verified.

Abstract

In the marine industry, heave compensation systems are applied to marine equipment to compensate for the adverse effects of waves and the hydraulic system is usually used as the power system of heave compensation systems. This article introduces importance theory to the opportunistic maintenance (OM) strategy to provide guidance for the maintenance of heave compensation systems. The working principle of a semi-active heave compensation system and the specific working states of its hydraulic components are also first explained. Opportunistic maintenance is applied to the semi-active heave compensation system. Moreover, the joint integrated importance measure (JIIM) between different components at different moments is analyzed and used as the basis for the selection of components on which to perform PM, with the ultimate goal of delaying the degradation of the expected performance of the system. Finally, compared with conditional marginal reliability importance (CMRI)-based OM, the effectiveness of JIIM-based OM is verified by the Monte Carlo method.

Keywords

opportunistic maintenance, importance measure, heave compensation, hydraulic system, Monte Carlo.

This is an open access article under the CC BY license (<https://creativecommons.org/licenses/by/4.0/>)

1. Introduction

Heave compensation systems keep offshore operation platforms stable via active or passive compensation, thereby overcoming the adverse effects of sea wind, waves, ocean currents, etc., on offshore operations [6, 12]. Since 1970, the heave compensation systems have been developed rapidly, and have been widely used in offshore drilling platforms, offshore cranes, and underwater towing systems, thereby improving the accuracy and reliability of offshore operations [25, 28]. Rotary heave compensation systems are usually driven by a hydraulic motor to drive the winch, and while the compensation stroke is not limited, the control is difficult and characterized by low accuracy. A hydraulic cylinder is usually used as the actuator of linear heave compensation systems and is used in conjunction with a pulley block. Linear heave compensation systems have the advantages of high control accuracy and the convenient combination of active and passive control, but the compensation stroke is limited by the stroke of the hydraulic cylinder. In semi-active heave compensation system, the passive subsystem equilibrates the static load, and the active subsystem equilibrates the dynamic movement. Semi-active heave

compensation systems are characterized by the advantages of both passive and active heave compensation systems. Li et al. designed a semi-active heave compensation system for underwater heavy towing equipment on a supply ship, the load of which can reach several hundred tons [17]. The hydraulic system provides a high actuator power density, which fully meets the power requirements of the heave compensation system [20]. As the core of the heave compensation system, the hydraulic system determines the accuracy and efficiency of compensation, and its reliability affects the safe and reliable operation of the entire compensation system.

Maintenance strategy models and their optimization have always been an important branch of reliability engineering. Many scholars, such as Wang and Ahmad and Kamaruddin, have systematically reviewed the related research in the maintenance field [1, 27]. Maintenance strategies can be divided into three categories: corrective maintenance (CM), preventive maintenance (PM), and condition-based maintenance (CBM). PM refers to the maintenance of important components at regular intervals or at specified moments before failure, which is a type of active maintenance. The purpose of PM is to improve the reliability of the system and reduce the probability

(*) Corresponding author.

E-mail addresses: C. Zhang - czhangstar@gmail.com, Y. Qian - qyj318@buaa.edu.cn, H. Dui - duihongyan@zzu.edu.cn, S. Wang - shaopingwang@vip.sina.com, R. Chen - rentongchen@buaa.edu.cn, M. M. Tomovic - mtomovic@odu.edu

of failure [4, 18, 19]. The components of a multi-component system often have structural dependence, economic dependence, and failure dependence, due to which it is difficult to achieve optimal maintenance by implementing the three maintenance strategies defined previously. Therefore, opportunistic maintenance (OM) for multi-component systems have been proposed. OM is generally defined as the performance of CM on a component when it fails, while the remaining components obtain the opportunity for PM [13]. The problem of component selection will be encountered in active maintenance strategies. A larger number of maintenance components can better improve the reliability and performance of the system, but cost and time constraints will limit the amount of maintenance. Researchers have been keen to study system maintenance optimization problems. Tan et al. proposed a Root Cause Based Maintenance (RCBM) strategy for the hemodialysis machine to minimize maintenance costs and improve reliability, and optimized the strategy with genetic algorithm [26]. Özcan et al. proposed a new model for the maintenance strategy optimization problem considering the multi-objective and multicriteria structure of hydroelectric power plants with hundreds of complex equipment [22]. Bukowski et al. proposed a new approach to system maintenance based on resilience concept [3]. Babishin et al. used genetic algorithm to optimize the non-periodic maintenance policies of the k-out-of-n:G system and to minimize the expected total cost [2]. Huynh et al. proposed a multi-level maintenance policy that combines both system- and component-level maintenance [11]. The proposed maintenance policy considers the interactions among components, and avoids inopportune interventions. Chong et al. analyzed and discussed the literature related to maintenance priority [5]. Golbasi et al. proposed a maintenance priority methodology for system components based on reliability allocation [10]. Saleh et al. proposed a new model for preventive maintenance priority of medical equipment [23].

Importance measures are used to identify the weak links of a system. On this basis, importance measures are gradually used to guide the selection of multi-component maintenance. Kuo and Zuo systematically summarized the development and recent advances of importance measures [14, 15]. Compared with various optimization algorithms, importance measures have no complicated optimization process, and can therefore more simply and quickly provide guidance for the maintenance of actual systems. Nguyen et al. used the structural importance measure for the selection of spare parts and PM actions in a multi-component system [21]. Dui et al. proposed a cost-based integrated importance measure to select the component or group of components for PM [8]. Lee et al. made decision of maintenance priority order for substation facility through structural importance [16]. Importance measures are also used as an indicator of opportunity maintenance. For example, Wu proposed joint reliability importance measures to evaluate how two components interactively contribute to system performance, which guides the selection of another component for maintenance [29]. Wu et al. proposed component maintenance priority (CMP) to select components for PM to maximally improve the reliability of the system given the failure of a component [30]. Dui et al. proposed the extended joint integrated importance measure (JIIM) to select components for PM to optimally improve the system performance [7].

As illustrated by the existing literature, many studies have focused on the reliability and maintenance strategies of hydraulic systems. However, the hydraulic system of a heave compensation system lacks corresponding maintenance strategies. In recent years, the research on performance-related importance has made great progress, and importance measures have been increasingly used in various types of maintenance strategies. In this paper, the working principle of the hydraulic system of a semi-active heave compensation system with redundant hydraulic components is first analyzed, and the major hydraulic components are then extracted. A maintenance model for the hydraulic system of the heave compensation system is then presented based on the JIIM. When a component fails, the component selected for OM can be determined by the proposed model. The maintenance

strategy of the system is limited by maintenance resources. The optimal maintenance strategy for complex systems is too tedious or even difficult to achieve. The maintenance-oriented importance measures can be used to evaluate the relative maintenance priority of components. Opportunistic maintenance strategies based on JIIM can provide faster and simpler component maintenance selection guidance for heave compensation systems.

The remainder of this paper is organized as follows. Section 2 introduces the hydraulic system of a heave compensation system with redundant components, and reports the extraction of the major components. In Section 3, an OM model based on the JIIM is applied to the hydraulic system. Section 4 presents OM strategies for implementation when different components fail at different times. Finally, the conclusions of this research are provided in Section 5.

2. Heave compensation system

2.1. System working principle

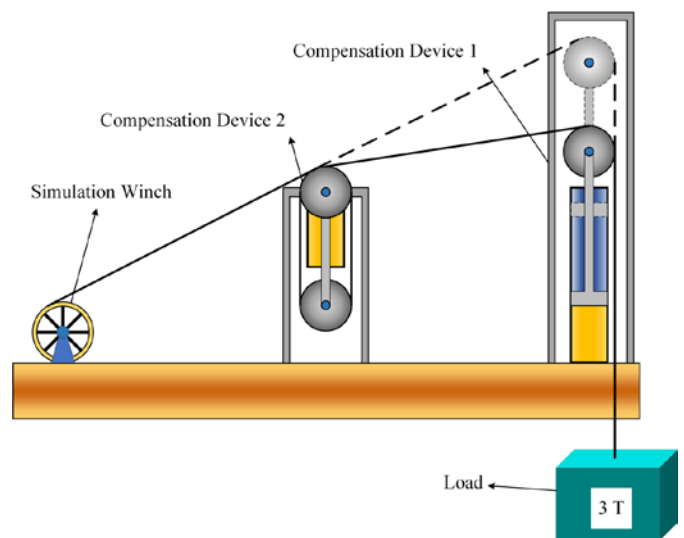

Fig. 1. Schematic diagram of the experimental heave compensation system

A schematic diagram of the experimental semi-active heave compensation system designed by Li et al. [17] is shown in Fig. 1. The system consists of three subsystems: a simulation winch, compensation device 1, and compensation device 2. The function of the simulation winch is to simulate the heave motion of a ship in waves. This is achieved by controlling a low-speed, high-torque hydraulic motor via a servo valve. An encoder measures the angle of the winch and consists of a closed-loop control system. Compensation device 1 and compensation device 2 are actuators with different structures and control methods. In terms of their mechanical structures, compensation device 2 adopts a pulley set composed of two fixed pulleys and one movable pulley, while compensation device 1 has only one movable pulley. The advantage of the movable pulley is that it can achieve double displacement compensation and reduce the size of the heave compensation system. The movable pulleys are driven by hydraulic cylinders, and the hydraulic system is the core of the heave compensation system.

A schematic diagram of the hydraulic system is illustrated in Fig. 2. The heave compensation system considered in this research is semi-active, and its advantages were explained in the research by Zhang et al. [31]. The hydraulic system can be divided into three parts: a power system, a control system, and actuators. The power system includes three hydraulic pumps and three accumulators. The hydraulic pumps provide hydraulic energy to the entire system, including the hydraulic cylinders and accumulators. The function of the accumulators is to equilibrate static loads and achieve passive compensation. The control

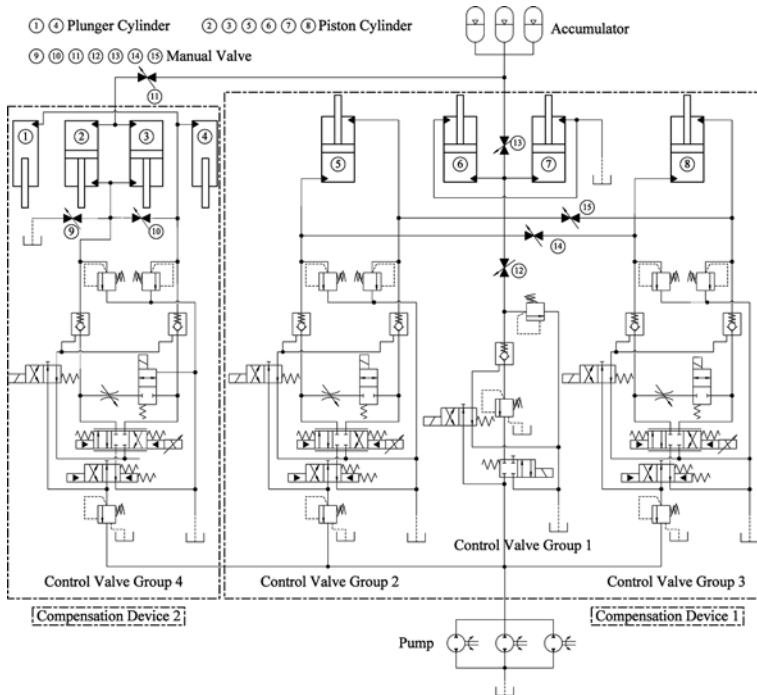

Fig. 2. Schematic diagram of the hydraulic system

Table 1. Important components of the system

Code	Name	Code	Name
X1	Pump 1	X10	Valve group 3
X2	Pump 2	X11	AHC cylinder 1_1
X3	Pump 3	X12	AHC cylinder 1_2
X4	Accumulator 1	X13	Valve group 4
X5	Accumulator 2	X14	PHC cylinder 2_1
X6	Accumulator 3	X15	PHC cylinder 2_2
X7	PHC cylinder 1_1	X16	AHC cylinder 2_1
X8	PHC cylinder 1_2	X17	AHC cylinder 2_2
X9	Valve group 2		

system consists of four control valve groups that play different roles in the hydraulic system. Control valve group 1, which is connected to three accumulators, controls the process of charging or releasing the accumulators to equilibrate the changing static loads when performing different tasks. In control valve group 1, when the solenoid directional control valves and the manual valves are switched on, the accumulators will be charged or released. Control valve groups 2, 3, and 4 are the same, and are respectively connected to piston cylinders. The servo valve can control the direction of hydraulic oil flow only when the solenoid directional control valves, which are safety valves, are opened at the same time. The electromagnetic switching valve and speed regulator valve conduct two chambers of each piston cylinder when equilibrating static loads. The actuators include eight hydraulic cylinders. In compensation device 1, the rodless chambers of piston cylinders 6 and 7, which are PHC cylinders, are connected to accumulators, while the rod chambers are directly connected to a tank. Piston cylinders 5 and 8, which are AHC cylinders, are connected to control valve groups 2 and 3, respectively. In compensation device 2, the AHC cylinders are plunger cylinders, which is different from compensation device 1. The sizes of piston cylinders 2 and 3, which are PHC cylinders, are the same as those in compensation device 1. The rodless chambers are also connected to accumulators, but the rod chambers are connected to control valve group 4. Therefore, the mov-

able pulley can actuate downward when the plunger cylinders are powered, and can actuate upward when the rod chambers of the piston cylinders are powered. Magnetostrictive sensors are installed on all hydraulic cylinders to provide displacement feedback signals. During heave compensation system operation, heave compensation devices 1 and 2 do not work at the same time, and it is almost impossible to control devices 1 and 2 to work simultaneously.

2.2. Component list

All the hydraulic components of the heave compensation system are presented in Fig. 2. To simplify the model, some components that have a small impact on the system, such as manual valves and pipes, are ignored based on engineering experience. Control valve group 1 only works when adjusting the accumulator. The working time of this control valve group is much less than that of other components, and the failure rate is much lower. Thus, control valve group 1 is ignored. The simulated winch is only present in the experimental heave compensation system, and does not appear in actual marine systems. Therefore, the simulated winch is not considered in this paper. Some other components are considered as a whole because of their relationships. For example, there are 10 components in control valve group 2 (or 3 or 4), and they are considered as a single component. In summary, the 17 important components of the system are listed in Table. 1.

3. Opportunistic maintenance model

In this section, the JIIM is applied to the experimental heave compensation system, and the components selected for OM are determined by the JIIM.

3.1. Component states

In Section 2, 17 important components of the semi-active heave compensation system were identified, and the following assumptions for these components are made in this study:

- (1) All components have two states, perfect and failure;
- (2) All components are in the perfect state at the beginning;
- (3) The probability that a component is in the perfect state is the reliability of the component;
- (4) The degradation rate of each component is its failure rate;
- (5) The failure time of all components follows the Weibull distribution $W(t, \theta, \gamma)$.

The Weibull distribution is a universally adaptive distribution, which is widely used to describe the life distribution of electromechanical products. The mechanical structure of the heave compensation system is symmetrical, and the same type of component has the same parameters. The scale and shape parameters of the failure time of each component are listed in Table. 2.

Table 2. Scale and shape parameters of each component's failure time

No.	Component	Code	θ	γ
1	Pump	X1, X2, X3	1850	2.36
2	Accumulator	X4, X5, X6	3304	1.46
3	Piston Cylinder	X7, X8, X11, X12, X14, X15	3501	2.023
4	Plunger Cylinder	X16, X17	3300	2.00
5	Valve Group	X9, X10, X13	3819	2.87

3.2. System state

Based on its structural design and working principle, the following assumptions are made for the heave compensation system:

- (1) Compensation device 1 and compensation device 2 work independently.
- (2) Static load is much larger than dynamic load.
- (3) Passive compensation is necessary, but active compensation is unnecessary.
- (4) The accumulator subsystem is a 2-out-of-3 subsystem. Only one accumulator can fail; otherwise, the system will fail.
- (5) When two-thirds of the hydraulic pumps fail, the system will still work.

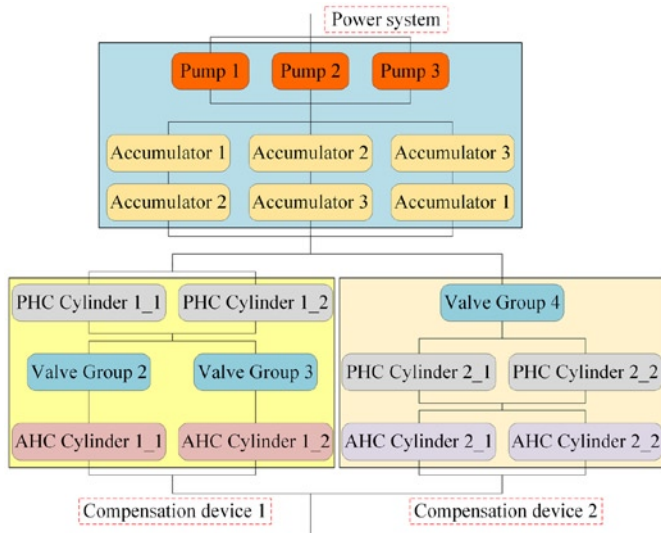

Fig. 3. The reliability block diagram of the heave compensation system

Based on assumption (1), the goal of heave compensation can still be achieved for the system when one device fails and the other is normal. Under assumptions (2) and (3), the passive compensation subsystem is more important than the active compensation subsystem. When the active compensation subsystem fails and the passive compensation subsystem is perfect, it is still considered that the purpose of compensation has been achieved, but the compensation efficiency is decreased. Accumulators are connected to the PHC cylinders to equilibrate the static load and play an important role in passive compensation, thereby justifying assumption (4). Although the pumps are also important in terms of power, the indicator when equilibrating static loads is pressure, rather than flow. Thus, in combination with assumption (3), assumption (5) is proposed.

Table 3. Power system states

State	Failed component		
1	Pump		
2	Pump	Pump	
3	Accumulator		
4	Accumulator	Pump	
5	Accumulator	Pump	Pump
6	Perfect state		
7	Failure state		

According to the assumptions and working principle of the experimental heave compensation system, the reliability block diagram is shown in Fig. 3. In the power system, three pumps are in parallel and the accumulator is a 2-out-of-3 subsystem. Thus, when the power system is still working but performance is degraded, component fail-

Table 4. Compensation device system states

State	Failed component	
1	AHC cylinder 1_1 or 1_2	AHC cylinder 2_1 or 2_2
2	AHC cylinder 1_1 or 1_2	PHC cylinder 2_1 or 2_2
3	AHC cylinder 1_1 or 1_2	Valve group 4
4	Valve group 2 or 3	AHC cylinder 2_1 or 2_2
5	Valve group 2 or 3	PHC cylinder 2_1 or 2_2
6	Valve group 2 or 3	Valve group 4
7	PHC cylinder 1_1 or 1_2	AHC cylinder 2_1 or 2_2
9	PHC cylinder 1_1 or 1_2	PHC cylinder 2_1 or 2_2
9	PHC cylinder 1_1 or 1_2	Valve group 4
10	Perfect state	
11	Failure state	

ures may occur in the pump or accumulator. The power system has 7 states, including 5 intermediate states, which are listed in Table 3. The compensation device is divided into compensation device 1 and compensation device 2. Due to their different mechanical designs and control methods, compensation devices 1 and 2 are delineated in the reliability block diagram. Once one of the compensation devices fails, another perfect compensation device can work to replace it immediately. Therefore, the performance of the entire compensation device will decrease only when the performance of both devices decreases simultaneously. The compensation device has 11 states, including 9 intermediate states, which are listed in Table 4. When one or more faults occur in the power system or compensation device, and when the subsystem is in an intermediate state, the heave compensation system can still work, albeit with lower performance.

3.3. The expected performance degradation based on the importance measure

The expected performance of a multi-state system $U(X(t))$ is defined as:

$$U(X(t)) = \sum_{j=1}^M a_j \Pr(\Phi(X(t))=j) \quad (1)$$

where a_j represents the system performance levels of state j , $\Phi(X(t)=j)$ is the structure function of the system and $\Pr(\Phi(X(t))=j)$ represents the probability that the system is in state j . From the total probability formula, $\Pr(\Phi(X(t))=j)$ can be expressed as the sum of the probability of component i failure and perfect state, which is expressed as follows:

$$\Pr(\Phi(X(t))=j) = \Pr[X_i(t)=1] \Pr[\Phi(1_i, X(t))=j] + \Pr[X_i(t)=0] \Pr[\Phi(0_i, X(t))=j] \quad (2)$$

According to the assumption of two-state components, the reliability $R_i(t)$ represents the probability that the component i is in perfect state and $\Pr(\Phi(X(t))=j)$ can be rewritten as:

$$\Pr(\Phi(X(t))=j) = R_i(t) \Pr[\Phi(1_i, X(t))=j] + (1 - R_i(t)) \Pr[\Phi(0_i, X(t))=j]. \quad (3)$$

Si et al. proposed the integrated importance measure (IIM) to rank the loss of system performance caused by component failure [24]. The IIM of component i is defined as:

$$IIM_i(t) = \sum_{j=1}^M a_j R_i(t) \lambda_i(t) \{ \Pr[\Phi(1_i, X(t)) = j] - \Pr[\Phi(0_i, X(t)) = j] \}, \quad (4)$$

where $R_i(t)$ represents the reliability of component i at time t , and $\lambda_i(t)$ is the failure rate of component i at time t .

The expected performance of the system will decrease as the working hours increase. The degradation of the expected system performance in unit time can be considered as the rate of degradation of the expected system performance and can be expressed as:

$$\begin{aligned} \frac{dU(X(t))}{dt} &= \frac{d\left(\sum_{j=1}^M a_j \Pr(\Phi(X(t)) = j)\right)}{dt} \\ &= \frac{d\left(\sum_{j=1}^M a_j \Phi(R_1(t), R_2(t), \dots, R_n(t))\right)}{dt} \\ &= \sum_{j=1}^M \sum_{i=1}^n a_j \frac{dR_i(t)}{dt} \frac{\partial \Phi(R_1(t), R_2(t), \dots, R_n(t))}{\partial R_i(t)} \\ &= \sum_{j=1}^M a_j \sum_{i=1}^n \frac{dR_i(t)}{dt} \frac{\partial \Phi(R_1(t), R_2(t), \dots, R_n(t))}{\partial R_i(t)} \\ &= \sum_{i=1}^n \sum_{j=1}^M a_j R_i(t) \frac{dR_i(t)/dt}{R_i(t)} \frac{\partial \Phi(R_1(t), R_2(t), \dots, R_n(t))}{\partial R_i(t)}. \end{aligned} \quad (5)$$

Because the failure rate of component i can be expressed as $\lambda_i(t) = -\frac{dR_i(t)/dt}{R_i(t)}$ and the partial derivative of the system with respect to component i $\frac{\partial \Phi(R_1(t), R_2(t), \dots, R_n(t))}{\partial R_i(t)}$ can be expressed as $\Pr[\Phi(1_i, X(t)) = j] - \Pr[\Phi(0_i, X(t)) = j]$, Eq. (5) can be rewritten as:

$$\frac{dU(X(t))}{dt} = -\sum_{i=1}^n \sum_{j=1}^M a_j R_i(t) \lambda_i(t) \{ \Pr[\Phi(1_i, X(t)) = j] - \Pr[\Phi(0_i, X(t)) = j] \}. \quad (6)$$

Combining Eq. (4) and Eq. (6), Dui et al. proved that the degradation of the expected system performance in unit time is the opposite of the sum of the IIM values of all components, which is expressed as follows [7]:

$$-\frac{dU(X(t))}{dt} = \sum_{i=1}^n IIM_i(t). \quad (7)$$

The degradation of the expected system performance in unit time can be considered as the rate of degradation of the expected system performance. The system degradation is the result of the joint action of all components, and the contribution of each component can be measured by its IIM. Therefore, the component with the largest IIM value has the greatest impact on the degradation of the expected system performance, and requires more attention.

When component m fails, the degradation of the expected system performance in unit time can be expressed as:

$$\begin{aligned} \frac{dU(0_m, X(t))}{dt} &= -\sum_{\substack{i=1 \\ i \neq m}}^n \sum_{j=1}^M a_j R_i(t) \lambda_i(t) \{ \Pr[\Phi(0_m, 1_i, X(t)) = j] - \Pr[\Phi(0_m, 0_i, X(t)) = j] \} \\ &= -\sum_{\substack{i=1 \\ i \neq m}}^n IIM^i(t)_{X_m(t)=0}, \end{aligned} \quad (8)$$

where $IIM^i(t)_{X_m(t)=0}$ is defined as:

$$IIM^i(t)_{X_m(t)=0} = \sum_{j=1}^M a_j R_i(t) \lambda_i(t) \{ \Pr[\Phi(0_m, 1_i, X(t)) = j] - \Pr[\Phi(0_m, 0_i, X(t)) = j] \}. \quad (9)$$

$IIM^i(t)_{X_m(t)=0}$ represents the contribution of component i to the degradation of system performance in unit time when component m fails. CM is performed on the failed component m , and the degradation of the expected system performance in unit time after CM can be expressed as:

$$\begin{aligned} \frac{dU(1_m, X(t))}{dt} &= -\sum_{\substack{i=1 \\ i \neq m}}^n \sum_{j=1}^M a_j R_i(t) \lambda_i(t) \{ \Pr[\Phi(1_m, 1_i, X(t)) = j] - \Pr[\Phi(1_m, 0_i, X(t)) = j] \} \\ &= -\sum_{\substack{i=1 \\ i \neq m}}^n IIM^i(t)_{X_m(t)=1}, \end{aligned} \quad (10)$$

where $IIM^i(t)_{X_m(t)=1}$ is defined as:

$$IIM^i(t)_{X_m(t)=1} = \sum_{j=1}^M a_j R_i(t) \lambda_i(t) \{ \Pr[\Phi(1_m, 1_i, X(t)) = j] - \Pr[\Phi(1_m, 0_i, X(t)) = j] \}. \quad (11)$$

$IIM^i(t)_{X_m(t)=1}$ represents the contribution of component i to the degradation of system performance in unit time when component m is perfect. Dui et al. proposed the JIIM to select the component for PM when a failed component is repaired [7]. When the component m is under repair, the JIIM of component i and m is defined as:

$$JIIM_m^i(t) = IIM^i(t)_{X_m(t)=1} - IIM^i(t)_{X_m(t)=0}. \quad (12)$$

The sum of JIIM of all components represents the change in the degradation rate of the expected system performance and can be expressed as:

$$\begin{aligned} \sum_{\substack{i=1 \\ i \neq m}}^n JIIM_m^i(t) &= \sum_{\substack{i=1 \\ i \neq m}}^n IIM^i(t)_{X_m(t)=1} - \sum_{\substack{i=1 \\ i \neq m}}^n IIM^i(t)_{X_m(t)=0} \\ &= -\frac{d(U(1_m, X(t)) - U(0_m, X(t)))}{dt}. \end{aligned} \quad (13)$$

3.3. OM model based on the JIIM

The flow chart of the OM model based on the JIIM is shown in Fig. 4. In this study, the failure time of all components follows the Weibull distribution $W(t, \theta, \gamma)$. In the Weibull distribution, the reliability of

component i can be expressed as $R_i = \exp\left[-\left(\frac{t}{\theta_i}\right)^{\gamma_i-1}\right]$ and the fail-

ure rate of component i can be expressed as $\lambda_i = \frac{\gamma_i}{\theta_i} \left(\frac{t}{\theta_i} \right)^{\gamma_i - 1}$. Accord-

ing to the system states, the expected system performance $U(X(t))$ and the IIM of each component can be calculated.

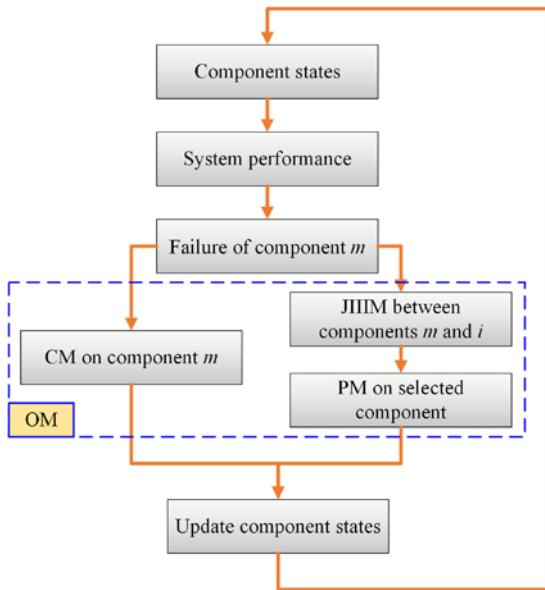

Fig. 4. Flow chart of OM model based on the JIIM

It is assumed that when a failure occurs in the system, the failure can be quickly identified and located. When component m fails, CM will be performed on it. In the case of component m failure, the degradation of system performance is considered to be caused by the remaining components, and $IIM^i(t)_{X_m(t)=0}$ is calculated. When perfect maintenance is performed on component m , component m is considered to be in the same perfect state as a new component. Thus, the degradation of system performance is also considered to be caused by the remaining components at this time, and $IIM^i(t)_{X_m(t)=1}$ is calculated. It can be seen from the definition that the contribution of component i to the degradation of system performance in unit time is different when component m fails or is perfect. From the perspective of a single component, the JIIM represents the difference in the contribution of component i to the degradation of system performance in unit time before and after component m is repaired. From a system perspective, the JIIM of all components represents the change in the rate of system performance degradation before and after the CM of component m . If the JIIM values of components m and i are positive, it means that the contribution of component i to the degradation of system performance in unit time increases because component m is repaired. Therefore, the components with positive JIIM values increase in importance, and the component with the largest JIIM value should be selected for PM. When the JIIM values are negative, the contribution will decrease, and the importance also decreases. JIIM is additive, so the improvement of the expected system performance is also additive when OM is performed. When resources are sufficient, more than one component can be selected for PM based on the JIIM ranking. Of course, additivity is limited by various factors, such as cost, time, etc.

Both the CM of the failed components and the PM of the selected components are considered as perfect maintenance. The states of the components being maintained will be updated and considered perfect after maintenance.

4. Case study

In this section, the model proposed in Section 3 is applied to the heave compensation system illustrated in Fig. 2. The JIIM between all components is discussed in this section.

4.1. Analysis of opportunistic maintenance based on the JIIM

When a component of the heave compensation system fails, the system stops working and CM or replacement will be performed on the failed component. This is also an opportunity to perform PM on the remaining components. One or a group of components with the highest priority for PM is selected based on the ranking of the component JIIM values so that the degradation of system performance in unit time is minimal when component m is repaired.

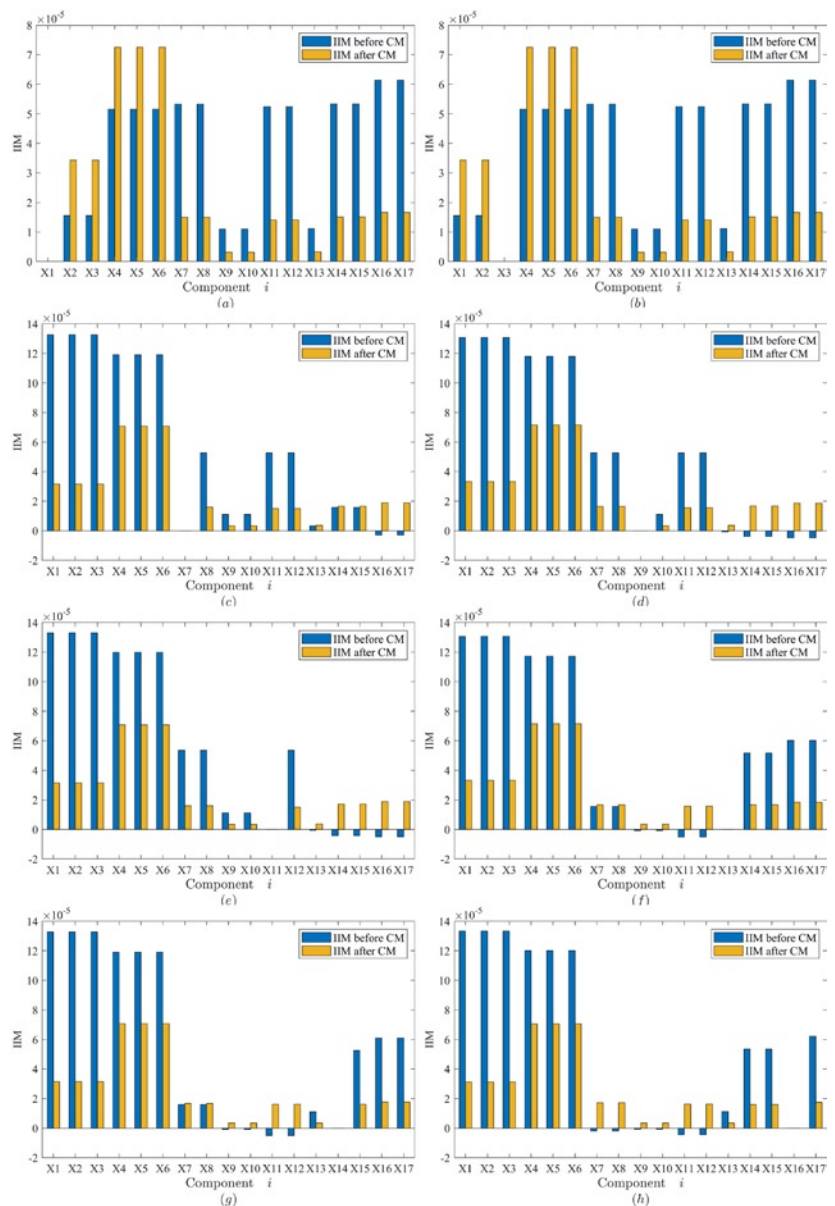

Fig. 5. The IIM values of different components with different failures at 500 h: (a) Pump failure; (b) Accumulator failure; (c) PHC cylinder 1_1 failure; (d) Valve group 2 failure; (e) AHC cylinder 1_1 failure; (f) Valve group 4 failure; (g) PHC cylinder 2_1 failure; (h) AHC cylinder 2_1 failure

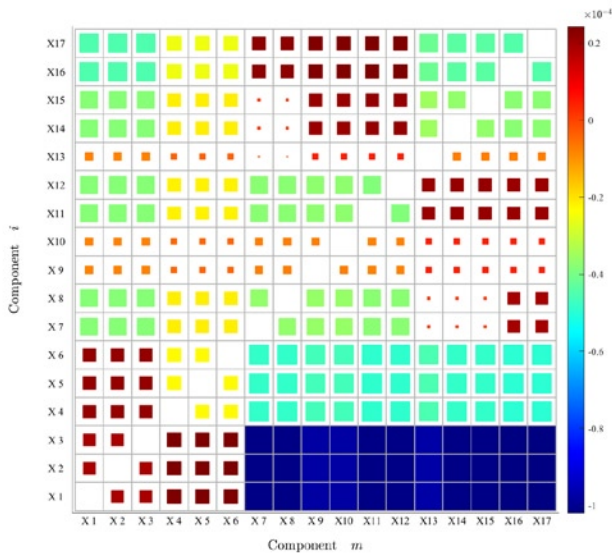

Fig. 6. The JIIM values between component m and component i at 500 h

Based on Eq. (12), it is known that $JIIM_m^i(t)$ is the difference in the IIM of component i before and after component m is repaired. Fig. 5 presents the IIM values of component i before and after the CM of a faulty component at 500 h when different components are repaired due to failures. As shown in Fig. 5 (a), when a pump fails but CM has not been performed, the IIM values of the pumps and valve groups are less than those of the other components, which means that the other components contribute more to system performance degradation and are more important. After CM is performed on the failed pump, the IIM values of the accumulators are the largest, those of the other pumps are the second-largest, and those of the remaining components are smaller. The IIM of the component has changed due to the pump being repaired. The IIM values of pumps and accumulators increase due to the CM of a pump, meaning that the importances of pumps and accumulators increase correspondingly. Meanwhile, the IIM values of the remaining components decrease. The IIM of the accumulator increases the most after the pump is repaired, which implies that the accumulator should be selected for PM.

The JIIM values between all components at different times were calculated in MATLAB 2020a. In the color bars presented in Figs. 6 and Fig. 7, the area of the square represents the absolute value of the JIIM, the exact JIIM values of all components can be obtained.

In Fig. 6, most JIIM values at 500 h are negative, meaning that the contribution of most components to system performance degradation in unit time decreases, as do the importances of most components, when any component is repaired. Specifically, when a pump fails, pumps and accumulators have larger JIIM values. Components in the compensation device have negative JIIM values. When an accumulator is repaired, only pumps have positive JIIM values, meaning the contribution of the pumps to the degradation of system performance in unit time increases. Therefore, a pump should be selected for PM. When a component in compensation device 1 is repaired, PM on the components in compensation device 2 has a positive impact on the degradation of system performance in unit time. Moreover, it is unnecessary to perform PM on pumps or other components in compensation device 1. When a component in compensation device 2 is repaired, the PM strategy is like that of compensation device 1, and the components in compensation device 1 should be selected for PM.

As shown in Fig. 7, most JIIM values at 1500 h are positive, meaning that the contribution of most components to system performance degradation in unit time increases, as does the importance, when any component is repaired. When a pump is under maintenance, the JIIM values of the remaining components are positive, and PM on an accumulator contributes the most to system performance degradation

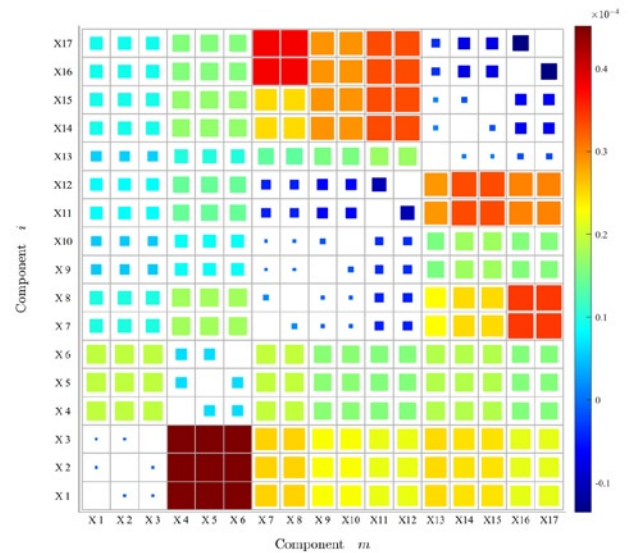

Fig. 7. The JIIM values between component m and component i at 1500 h

in unit time. When an accumulator is under maintenance, the pump is most worthy of PM. When a component in compensation device 1 or 2 is repaired, PM on a pump, an accumulator or a component in another compensation device has a positive effect. When different components in the compensation device fail, the components selected for PM are different. The valve groups always have the lowest maintenance priority because of their high reliability. JIIM values at different times are different; thus, it is significant to study the changes of JIIM values over time to formulate more accurate maintenance strategies for different failures at different times.

Fig. 8 presents the change of the JIIM values of the remaining components over time when different components are repaired. As presented in Figs. 8(a) and 8(b), when a pump or an accumulator is repaired, the contribution of the components in compensation device 1 and 2 first decreases and then increases. On the contrary, the contributions of pumps and accumulators first increase and then decrease. If a pump is repaired, the accumulator contributes the most to the degradation of system performance in unit time at all times. If an accumulator is repaired, the pump is most worthy of PM at all times. Figs. 8(c), 8(d), and Fig. 8(e) respectively present the changes of the JIIM values over time when a PHC cylinder, a valve group, and an AHC cylinder in compensation device 1 is repaired. It is unnecessary to perform PM on the remaining components before 200 h due to the negative JIIM values. After 500 hours, the components in compensation device 2 are worthy of PM, and the first component is selected for PM based on the ranking of the component JIIM values. When a component in compensation device 1 fails and is repaired at about 950 h, the benefit of PM on a component in compensation device 2 at this time is greater than that at other times. Figs. 8(f), 8(g), and 8(h) respectively present the change of the JIIM value over time when a valve group, a PHC cylinder, and an AHC cylinder in compensation device 2 is repaired. As shown in Figs. 8(f) and 8(g), when a valve group or a PHC cylinder in compensation device 2 is repaired, no component is worthy of PM before 200 h based on the JIIM theory. After 200 h, PM on the AHC cylinder in compensation device 1 will contribute the most to slowing system performance degradation in unit time. As shown in Fig. 8(h), when an AHC cylinder in compensation device 2 is repaired, the importance of the PHC cylinder in compensation device 1 increases the most, and a PHC cylinder should be selected for PM so that the system performance degradation in unit time will slow the most.

4.2. Effectiveness comparison

Gao et al. proposed conditional marginal reliability importance (CMRI) to decide which component should be given more attention,

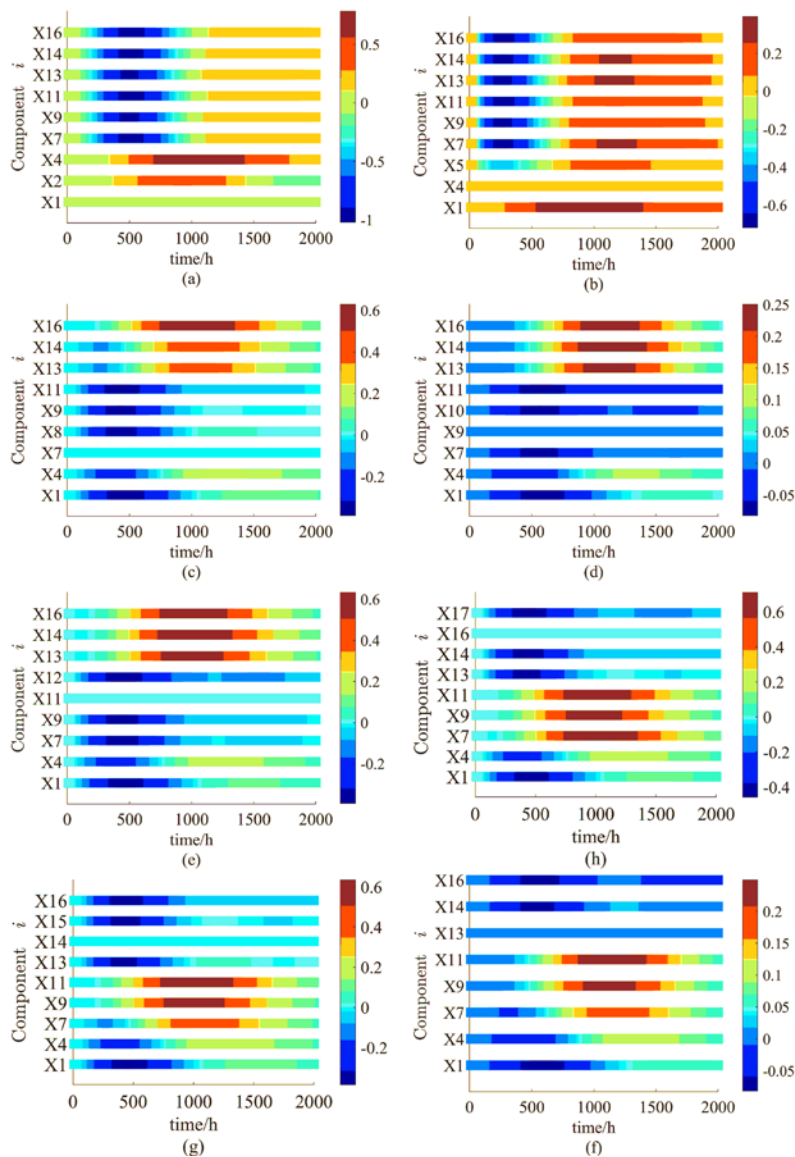

Fig. 8. The change of the JIIM values over time when different components are repaired: (a) Pump repair; (b) Accumulator repair; (c) PHC cylinder 1_1 repair; (d) Valve group 2 repair; (e) AHC cylinder 1_1 repair; (f) Valve group 4 repair; (g) PHC cylinder 2_1 repair; (h) AHC cylinder 2_1 repair

given that some components are failed [9]. To verify the effectiveness of the JIIM-based OM strategy proposed in this paper, it was compared with the CMRI-based OM strategy. The JIIM-based OM strategy is described as the calculation of the JIIM values of the remaining components when a component is repaired due to a sudden failure, and the selection of the component with the largest JIIM value for PM. It should be noted that the JIIM value of the component will change due to the passage of time and the maintenance of the component. Perfect maintenance or replacement will be performed on the CM component and the PM component, and the repaired components will be in the perfect state after maintenance. The Monte Carlo method was used to simulate the failure and maintenance of the heave compensation system. It was assumed that the mean time to failure (MTTF) of the component obeys the Weibull distribution, and that the MTTFs of the maintained components will be updated after maintenance. The step length of the simulation was set to 1 h, the total time length was set to 2000 h, and the number of Monte Carlo iterations was 100,000. The expected performance of the heave compensation system at 2000 h was used as an index to evaluate the effectiveness of OM.

A record of the failure and maintenance of the heave compensation system under JIIM-based OM is presented in Table. 5. When different

components fail at different times, the JIIM values must be recalculated to select components for PM. For this simulated record, the heave compensation system failed for the first time and pump X3 failed at 487 h. According to Fig. 8(a), the PM of the accumulator had the highest priority. Therefore, CM was performed on pump 1 X3, while PM was performed on accumulator 2 X5. The second failure of the system occurred a 740 h on accumulator 1 X4. CM was performed on accumulator 1 X4, while PM was performed on pump 1 X1. At 1151 h, AHC cylinder 2_1 X16 failed, and CM was performed. When the last accumulator 3 X6, which had not been repaired, failed at 1339 h, PM was performed on the last pump 2 X2, which had not been repaired. When PHC cylinder 1_2 X8 failed at 1395 h, PM was performed on AHC cylinder 2_2 X17. From this record, and combined with Fig. 8, the following rules can be determined. (1) Components with low reliability usually fail first and have a higher priority for CM or PM. (2) The reliability of repaired components is improved and maintenance priority is reduced. (3) The PM selections obtained from Fig. 8 are generally the same as those obtained via accurate JIIM calculations. Although Fig. 8 only represents the JIIM values between components when the system first fails, it is still instructive.

Fig. 9 presents the probability density diagram of the expected performance of the heave compensation system under CMRI-based OM and JIIM-based OM at 2000 h. As shown in Fig. 9, when performing JIIM-based OM, CM was performed on the failed component. Under JIIM-based OM, CM was performed on the failed component, and PM was performed on the component with the largest JIIM value. When performing CMRI-based OM, CM was performed on the failed component, and PM was performed on the component with the largest CMRI. Under JIIM-based OM, the expected performance of the heave compensation system was concentrated around 0.23 after 2000 h of operation. However, under CMRI-based OM, the expected performance was concentrated around 0.19 at 2000 h. In addition, under JIIM-based OM, the heave compensation system was more likely to achieve higher performance after 2000 h. It can be seen from Fig. 9 that JIIM-based OM was more effective than CMRI-based OM in improving the expected performance of the heave compensation system. This is because the JIIM considers the impact of component maintenance on the expected performance of the system, but CMRI only considers the impact of component reliability.

Table 5. A simulated record of failure and maintenance under JIIM-based OM

Failure Time/h	487	740	1151	1339	1395
Component for CM	X3	X4	X16	X6	X8
Component for PM	X5	X1	X7	X2	X17

The distribution of the maintained components, including those maintained via CM and PM, were then obtained via 100,000 Monte Carlo simulations, as shown in Fig. 10. As shown in Fig. 10, the maintenance of the three pumps occurred the most often, accounting for 31% of the total maintenance. The maintenance of piston cylinders accounted for 28% of the total maintenance, which was caused by up to 6 piston cylinders. The maintenance of three accumulators and two plunger cylinders both accounted for 17%. The maintenance proportion of the three valve groups was the lowest, accounting for only 7%.

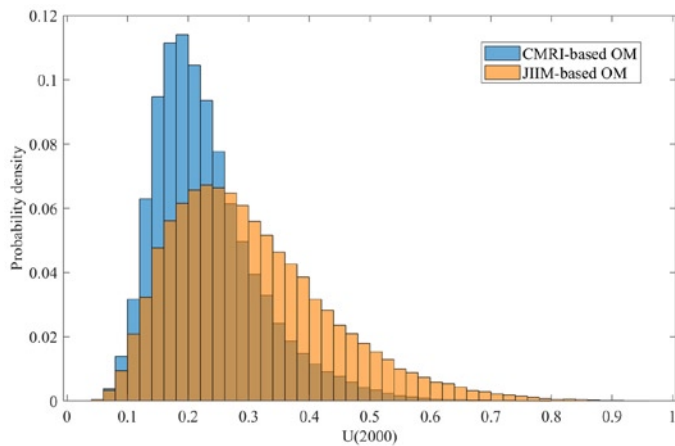

Fig. 9. The probability density of the expected performance of the heave compensation system

For components that account for a relatively high maintenance rate, more spare components can be prepared in advance.

5. Conclusion and future work

In this paper, JIIM-based OM was applied to the maintenance of a semi-active heave compensation system to slow down the degradation of expected system performance. The JIIM is the difference between the IIM before and after the failed component is repaired, which is illustrated by bar graphs. In the case of different component failures at different times, the corresponding component for which PM should be performed is determined according to JIIM-based OM. Via the Monte Carlo method, it was verified that JIIM-based OM is superior to CMRI-based OM in slowing down the degradation of the expected

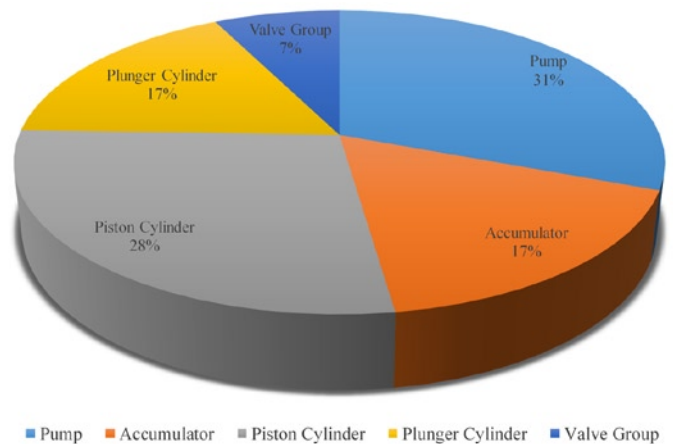

Fig. 10. The distribution of maintained components

system performance. A typical component failure and repair record was analyzed, and the predicted maintenance percentages of various components were also illustrated by a pie chart.

Future work will include the development of multi-level maintenance strategies for CM and PM, and the economic dependence of the components will also be considered.

Acknowledgements

The authors gratefully acknowledge the financial support for this research from the National Key Research and Development Program of China (Grant No. 2019YFB2004504), the National Natural Science Foundation of China (Grant Nos. 51875015, 51620105010) and the Aviation Science Foundation (Grant No. 201902051001).

References

- Ahmad R, Kamaruddin S. An overview of time-based and condition-based maintenance in industrial application. *Computers & Industrial Engineering* 2012; 63: 135-149, <https://doi.org/10.1016/j.cie.2012.02.002>.
- Babishin V, Hajipour Y, Taghipour S. Optimisation of non-periodic inspection and maintenance for multicomponent systems. *Eksplotacja i Niezawodność - Maintenance and Reliability* 2018; 20 (2): 327-342, <https://doi.org/10.17531/ein.2018.2.20>.
- Bukowski L, Werbińska-Wojciechowska S. Using fuzzy logic to support maintenance decisions according to Resilience-Based Maintenance concept. *Eksplotacja i Niezawodność - Maintenance and Reliability* 2021; 23: 294-307, <https://doi.org/10.17531/ein.2021.2.9>.
- Chen C, Wang C, Lu N, Jiang B, Xing Y. A data-driven predictive maintenance strategy based on accurate failure prognostics. *Eksplotacja i Niezawodność - Maintenance and Reliability* 2021; 23: 387-394, <https://doi.org/10.17531/ein.2021.2.19>.
- Chong A K W, Mohammed A H, Abdullah M N, Rahman M S. Maintenance prioritization - a review on factors and methods. *Journal of Facilities Management* 2019; 17 (1), 18-39, <https://doi.org/10.1108/JFM-11-2017-0058>.
- Do K D, Pan J. Nonlinear control of an active heave compensation system. *Ocean Engineering* 2008; 35: 558-571, <https://doi.org/10.1016/j.oceaneng.2007.11.005>.
- Dui H Y, Li S M, Xing L D, Liu H L. System performance-based joint importance analysis guided maintenance for repairable systems. *Reliability Engineering & System Safety* 2019; 186: 162-175, <https://doi.org/10.1016/j.res.2019.02.021>.
- Dui H Y, Si S B and Yam R C M. A cost-based integrated importance measure of system components for preventive maintenance. *Reliability Engineering & System Safety* 2017; 168: 98-104, <https://doi.org/10.1016/j.res.2017.05.025>.
- Gao X L, Cui, L R, Li J L. Analysis for joint importance of components in a coherent system. *European Journal of Operational Research* 2007; 182: 282-299, <https://doi.org/10.1016/j.ejor.2006.07.022>.
- Golbasi O, Demirel N. Risk-based reliability allocation methodology to set a maintenance priority among system components: A case study in Mining. *Eksplotacja i Niezawodność - Maintenance and Reliability* 2017; 19(2): 191-202, <https://doi.org/10.17531/ein.2017.2.6>.
- Huynh K T, Barros A, Bérenguer C. Multi-Level Decision-Making for The Predictive Maintenance of k-Out-of-n: F Deteriorating Systems. *IEEE Transactions on Reliability* 2015; 64: 94-117, <https://doi.org/10.1109/TR.2014.2337791>.
- Kuechler S, Mahl T, Neupert J, Schneider K, Sawodny O. Active Control for an Offshore Crane Using Prediction of the Vessel's Motion. *IEEE/ASME Transactions on Mechatronics* 2011; 16: 297-309, <https://doi.org/10.1109/TMECH.2010.2041933>.
- Kumar V, Kumar G, Singh RK, Soni U. Degrading systems availability analysis: analytical semi-Markov approach. *Eksplotacja i Niezawodność - Maintenance and Reliability* 2021; 23 (1): 195-208, <https://doi.org/10.17531/ein.2021.1.20>.
- Kuo W, Zhu X. Relations and Generalizations of Importance Measures in Reliability. *IEEE Transactions on Reliability* 2012; 61: 956-674, <https://doi.org/10.1109/TR.2012.2194196>.
- Kuo W, Zhu X. Some Recent Advances on Importance Measures in Reliability. *IEEE Transactions on Reliability* 2012; 61: 344-360, <https://doi.org/10.1109/TR.2012.2194196>.
- Lee S H, Lee Y S, Kim J O. Decision of Maintenance Priority Order for Substation Facility through Structural Importance and Fault

- Analysis. *Journal of the Korean Institute of Illuminating and Electrical Installation Engineers* 2013; 27(4), 23-30, <https://doi.org/10.5207/JIEIE.2013.27.4.023>.
17. Li S Z, Wei J H, Guo K, Zhu W L. Nonlinear Robust Prediction Control of Hybrid Active-Passive Heave Compensator With Extended Disturbance Observer. *IEEE Transactions on Industrial Electronics* 2017; 64: 6684-6694, <https://doi.org/10.1109/TIE.2017.2698358>.
 18. Lotovskiy E, Teixeira AP, Guedes Soares C. Availability analysis of an offshore oil and gas production system subjected to age-based preventive maintenance by Petri Nets. *Eksploracja i Niezawodność - Maintenance and Reliability* 2020; 22: 627-637, <https://doi.org/10.17531/ein.2020.4.6>.
 19. Młynarski S, Pilch R, Smolnik M, Szybka J, Wiązania G. A model of an adaptive strategy of preventive maintenance of complex technical objects. *Eksploracja i Niezawodność - Maintenance and Reliability* 2020; 22: 35-41, <https://doi.org/10.17531/ein.2020.1.5>.
 20. Nespoli A, Besseghini S, Pittaccio S, Villa E, Viscuso S. The high potential of shape memory alloys in developing miniature mechanical devices: A review on shape memory alloy mini-actuators. *Sensors and Actuators A: Physical* 2010; 158: 149-160, <https://doi.org/10.1016/j.sna.2009.12.020>.
 21. Nguyen KA, Do P, Grall A. Condition-based maintenance for multi-component systems using importance measure and predictive information. *International Journal of Systems Science: Operations & Logistics* 2014; 1: 228-245, <https://doi.org/10.1080/23302674.2014.983582>.
 22. Özcan E, Yumuşak R, Eren T. A novel approach to optimize the maintenance strategies: a case in the hydroelectric power plant. *Eksploracja i Niezawodność - Maintenance and Reliability* 2021; 23: 324-337, <https://doi.org/10.17531/ein.2021.2.12>.
 23. Saleh N, Sharawi A A, Abd Elwahed M, et al. Preventive maintenance prioritization index of medical equipment using quality function deployment. *IEEE Journal of Biomedical and Health Informatics* 2014; 19(3): 1029-1035, <https://doi.org/10.1109/JBHI.2014.2337895>.
 24. Si S, Dui H, Zhao X, Zhang S, Sun, S. Integrated importance measure of component states based on loss of system performance. *IEEE Transactions on Reliability* 2012; 61: 192-202, <https://doi.org/10.1109/TR.2011.2182394>.
 25. Southerland JR. Mechanical systems for ocean engineering. *Naval Engineers Journal* 1970; 82: 63-74, <https://doi.org/10.1111/j.1559-3584.1970.tb04361.x>.
 26. Tan CM, Na rula U, La i LA, Pandey S, Tung JH, Li CY. Optimal maintenance strategy on medical instruments used for haemodialysis process. *Eksploracja i Niezawodność - Maintenance and Reliability* 2019; 21: 318-328, <https://doi.org/10.17531/ein.2019.2.17>.
 27. Wang H. A survey of maintenance policies of deteriorating systems. *European Journal of Operational Research* 2002; 139: 469-489, [https://doi.org/10.1016/S0377-2217\(01\)00197-7](https://doi.org/10.1016/S0377-2217(01)00197-7).
 28. Woodacre J K, Bauer R J, Irani R A. A review of vertical motion heave compensation systems. *Ocean Engineering* 2015; 104, 140-154, <https://doi.org/10.1016/j.oceaneng.2015.05.004>.
 29. Wu, S. Joint importance of multistate systems. *Computers & Industrial Engineering* 2005; 49: 63-75, <https://doi.org/10.1016/j.cie.2005.02.001>.
 30. Wu S, Chen Y, Wu Q, Wang, Z. Linking component importance to optimisation of preventive maintenance policy. *Reliability Engineering & System Safety* 2016; 146: 26-32, <https://doi.org/10.1016/j.res.2015.10.008>.
 31. Zhang C, Qian Y, Dui H, Wang S, Shi J. Component failure recognition and maintenance optimization for offshore heave compensation systems based on importance measures. *Journal of Loss Prevention in the Process Industries* 2020; 63, <https://doi.org/10.1016/j.jlp.2019.103996>.