

Yale University

## EliScholar – A Digital Platform for Scholarly Publishing at Yale

---

Yale Graduate School of Arts and Sciences Dissertations

---

Spring 2021

### Essays on Game and Economic Theory

Xiangliang Li

*Yale University Graduate School of Arts and Sciences, lxlnemo@gmail.com*

Follow this and additional works at: [https://elischolar.library.yale.edu/gsas\\_dissertations](https://elischolar.library.yale.edu/gsas_dissertations)

---

#### Recommended Citation

Li, Xiangliang, "Essays on Game and Economic Theory" (2021). *Yale Graduate School of Arts and Sciences Dissertations*. 79.

[https://elischolar.library.yale.edu/gsas\\_dissertations/79](https://elischolar.library.yale.edu/gsas_dissertations/79)

This Dissertation is brought to you for free and open access by EliScholar – A Digital Platform for Scholarly Publishing at Yale. It has been accepted for inclusion in Yale Graduate School of Arts and Sciences Dissertations by an authorized administrator of EliScholar – A Digital Platform for Scholarly Publishing at Yale. For more information, please contact [elischolar@yale.edu](mailto:elischolar@yale.edu).

## Abstract

Essays on Game and Economic Theory

Xiangliang Li

2021

This dissertation studies a range of topics in game and economic theory.

Chapter 1 proposes a new solution to the two-player bargaining problem of Nash (1950): The Consensus solution. The Consensus solution maximizes the total amount of options that both players agree are worse than the solution but better than no-cooperation. It can be characterized by a simple equality. It satisfies all the axioms of the Nash solution except Axiom IIA (Independence of Irrelevant Alternatives); the Nash solution satisfies all its axioms except one, which says: when both players' utilities of no-cooperation become lower creating additional room for players to cooperate, then as long as options within the additional room are worse than the current solution, the solution shall not change. At the same time, it is the same as the Nash solution in comprehensive bargaining problems, a class of bargaining problems where many good properties of the Nash solution are discovered. We discuss when bargaining problems are non-comprehensive. We conclude that the key difference between the two solutions is that the Consensus solution emphasize what players can achieve via cooperation whereas the Nash solution focus more on the anticipation of no-cooperation.

Chapter 2, coauthored with with Treb Allen and Costas Arkolakis, studies a broad class of network models where a large number of heterogeneous agents simultaneously interact in many ways. We provide an iterative algorithm for calculating an equilibrium and offer

sufficient and “globally necessary” conditions under which the equilibrium is unique. The results arise from a multi-dimensional extension of the contraction mapping theorem which allows for the separate treatment of the different types of interactions. We illustrate that a wide variety of heterogeneous agent economies – characterized by spatial, production, or social networks – yield equilibrium representations amenable to our theorem’s characterization.

Chapter 3, coauthored with with Treb Allen and Costas Arkolakis, develops a quantitative general equilibrium model that incorporates the many economic interactions that occur over the city, including commuting and spatial spillovers of productivities. Despite the many spatial linkages, the model allows for characterizing the existence of the spatial equilibrium of the city even when the spillovers are much more general than what are usually considered in literature. We consider a city planner who designs zoning policies but leave the rest to the market. The goal of the city planner is chosen such that the planner’s difference compared with the market does not lie in redistribution but only efficiency. We provide an explicit formula to evaluate welfare effects of zoning policies.

Essays on Game and Economic Theory

A Dissertation  
Presented to the Faculty of the Graduate School  
of  
Yale University  
in Candidacy for the Degree of  
Doctor of Philosophy

by  
Xiangliang Li

Dissertation Director: Larry Samuelson, Costas Arkolakis and Xiaohong  
Chen

June 2021

Copyright © 2021 by Xiangliang Li

All rights reserved.

# Contents

- 1 The Consensus Bargaining Solution** **1**
- 1.1 Introduction . . . . . 2
- 1.2 Maximization . . . . . 8
  - 1.2.1 The Consensus Solution . . . . . 9
  - 1.2.2 Characterization . . . . . 10
  - 1.2.3 Comparison with the Nash solution . . . . . 14
- 1.3 Axiomatization . . . . . 19
- 1.4 Further Comparison . . . . . 27
  - 1.4.1 Isosolution . . . . . 27
  - 1.4.2 Situation of Bargaining . . . . . 28
  - 1.4.3 Different Subjective Views . . . . . 35
- 1.5 Other Discussions . . . . . 38
  - 1.5.1 (A)symmetry . . . . . 38
  - 1.5.2 Interpersonal Comparison . . . . . 39
  - 1.5.3 Axiom 5 . . . . . 40
- 1.6 Appendix . . . . . 41

1.6.1	Proof of Lemma 2 . . . . .	41
1.6.2	Formal Proof of Lemma 2 . . . . .	42
1.6.3	Proof of Lemma 3 . . . . .	48
1.6.4	Proof of Theorem 2b . . . . .	49
<b>2</b>	<b>On the Equilibrium Properties of Network Models with Heterogeneous Agents</b>	<b>52</b>
2.1	Introduction . . . . .	53
2.2	Main Results . . . . .	58
2.2.1	Main Theorem . . . . .	59
2.2.2	Remarks . . . . .	62
2.3	Applications . . . . .	65
2.3.1	Spatial Networks . . . . .	65
2.3.2	Production Networks . . . . .	66
2.3.3	Social Networks . . . . .	67
2.4	Conclusion . . . . .	68
2.5	Appendix . . . . .	69
2.5.1	Proof of Lemma 1 . . . . .	69
2.5.2	Proof of Theorem 1. . . . .	70
2.5.3	Further Details of Remarks . . . . .	74
2.5.4	Applications . . . . .	80
2.5.5	Additional Remarks . . . . .	95
<b>3</b>	<b>Optimal City Structure</b>	<b>98</b>

3.1	Introduction . . . . .	99
3.2	Model . . . . .	101
3.2.1	Model Setup . . . . .	101
3.2.2	Aggregation . . . . .	106
3.3	Equilibrium and Welfare Analysis . . . . .	109
3.3.1	Equilibrium Analysis . . . . .	109
3.3.2	Welfare Analysis . . . . .	111
3.4	Conclusion . . . . .	114
3.5	Appendix . . . . .	114
3.5.1	Derivation of expected wage income and productivity . . . . .	114
3.5.2	Proof of Proposition 1 . . . . .	116
3.5.3	Proof of Proposition 2 . . . . .	121
	<b>Bibliography</b>	<b>126</b>



# List of Figures

1.1	Hiking v.s. Biking . . . . .	5
1.2	Notations . . . . .	10
1.3	Illustration of the Proof of Lemma 2. . . . .	13
1.4	The areas that the Nash and Consensus solutions maximize. . . . .	15
1.6	Nash Solution v.s. Consensus Solution (The detailed description is Example 3.)	22
1.8	Isosolution: the set of threats that yield the same solution. . . . .	29
1.9	Situation of $(W, s)$ . . . . .	31
1.10	Situation of $W$ . . . . .	32
1.11	When the threat is in the grey area, the Nash and Consensus solutions are the same; otherwise, they are different. . . . .	35
1.12	Roadmap of the Proof of Lemma 2 . . . . .	44
1.13	Normal Vectors . . . . .	45

# Acknowledgements

First and foremost, I am immensely grateful to my advisers Larry Samuelson, Costas Arkolakis and Xiaohong Chen. Larry Samuelson taught me how to write my first paper, which would still be in its chaotic state without his countless hours of help. Outside the paper, he offered me—oftentimes in a humorous and cheering way—numerous invaluable advice, many of which I did not understand then but gradually became wise at later times. His mentorship is a unique combination of enlightenment and dedication, coming from an intelligent mind and pure heart. Working with him has fundamentally improved not only my professional skills but also life decision-makings. I am also deeply indebted to Costas Arkolakis. He helped me get both into and out of Yale. My life trajectory would be completely different without him. Over the years, he has invested tremendous time in me and his continual guidance and care have helped not only my academic career but also my life in general. He is both an invaluable mentor and dear friend. Meeting him has been one of my most beautiful stories in life. I am also extremely grateful to Xiaohong Chen. She has been very generous in allocating her time to me despite the fact that my work has nothing to do with econometrics. Talking with her has been one of my most enjoyable things at Yale. Her appreciation and belief in what I can achieve have given me great comforts. Her advice of

doing important things has big impacts on me and reinforces my belief to pursue my own passion. From time to time, my stubbornness may have frustrated my advisers but their supports have been unwavering. For these, I will be forever grateful. If someday I could see further, it is because I stand on their shoulders.

Within Yale community, I would also like to express my gratitude to Treb Allen, Ian Ball, Truman Bewley, Yi Chen, Chuan Du, John Geanakoplos, Timothy Guinnane, Ryota Iijima, Ming Li, Minghao Li, Samuel Kortum, Giuseppe Moscarini, Benjamin Polak, Xinyang Wang, Lezhen Wu, and Ge Zhang. They have helped or advised me on different occasions. Particularly, I'd like to thank Yi Chen, Minghao Li, and Xinyang Wang. They have offered me comprehensive help. I am also grateful to Kerry DeDomenico and Pamela O'Donnell for helping me with numerous administrative tasks . Finally, I appreciate the camaraderie of my colleagues in the economics department.

Outside Yale, I would like to thank my friends at Connecticut Soaring Association particularly David Mackenzie, Bill Kelly, Joe Palmisano, and Stephen Williams. Soaring with them has been one of my happiest memories in US.

I acknowledge the financial support that I received from Yale University and the Cowles Foundation for Research in Economics which supported my research and living expenses during the course of my Ph.D. study. Also, I acknowledge the financial support from National School of Development at Peking University before I came to Yale.

I am deeply grateful to my girlfriend Qianli Feng. She taught me how to make illustrative diagrams in computer. She oftentimes is the first listener of my research ideas and has always been appreciative. Also her company is irreplaceable.

Finally, I would like to thank my parents Huancun Chen and Bingcun Li. They give me

space for me to grow and love for me to flourish. My happiness under their care has been the ultimate source of strengths for me to laugh at and overcome all sorts of hardships.

# Chapter 1

## The Consensus Bargaining Solution

## 1.1 Introduction

Bargaining is a universal phenomenon arising from different economic problems e.g. allocation of resources, exchange of goods, and coordination of actions. In these problems, bargaining is only the phenomenon; behind it is the *fundamental question of cooperation*: there are many ways of cooperating, different players favor different ways, which way shall be chosen? Economists had long thought the answer arbitrary (e.g., Edgeworth, 1881, p. 29) until Nash (1950).

Nash (1950) proposes to identify a solution by a list of its desired properties (axioms) and implements the axiomatic approach within a simple bargaining model.

**Definition 1.** A *two-player bargaining problem* is a pair  $(W, s)$  where  $W \subset \mathbb{R}^2$  is the set of utilities that players 1 and 2 can obtain via cooperation and  $s \in \mathbb{R}^2$  is the pair of utilities obtained with no-cooperation and is usually called as *the threat*.

Within this bargaining problem, the solution example that Nash (1950) sets is the  $v \in W$  that maximizes  $(v_1 - s_1)(v_2 - s_2)$  and the Nash solution can be identified by four axioms.

Nash (1950)'s impacts are fundamental. First, there is a clear before-and-after. Afterwards, instead of regarding bargaining as indeterminate, economists have turned to find solutions and there have been many alternatives (for surveys, see Roth, 1979; Peters, 1992; Thomson, 1994). Second, despite the fact that there are many solutions, the Nash solution has remained the only one that is overwhelmingly used in applications. And these applications span almost all subfields of economics: macroeconomics (e.g., Calmfors and Driffill, 1988; Pissarides, 2000), industrial organization (e.g., Grossman and Hart, 1986; Tirole, 1988; Hart, 1995), political economy (e.g., Shleifer and Vishny, 1994; Grossman and Helpman, 2001), labor

economics (e.g., Manser and Brown, 1980; McElroy and Horney, 1981; Chiappori, 1992), and so on. And many of them have become classic works in their own fields.

Except for its self-evident simplicity, the wide applications of the Nash solution can be explained by its many appealing properties that people have found over the years. For example, Harsanyi (1956) finds it coincides with Zeuthen's solution (see Zeuthen), which is an equilibrium point in a psychological bargaining process where players' firmness is measured by their evaluation of risk; Sobel (1981) and Moulin (1983) show that it satisfies the property of midpoint domination; <sup>1</sup> Binmore (1984) shows that the Nash solution is closed under the multiplication defined between bargaining problems; Lensberg (1988) shows that the Nash solution is invariant in subproblems, which are obtained by fixing some players' utilities; Maschler et al. (1988) shows that the Nash solution is the solution of a dynamic system; Shapley (1988) points out that the Nash solution is the only solution such that, under some scaling transformation for individual utilities, the outcome is both egalitarian and utilitarian; Chun (1988); Peters and Van Damme (1991); Anbarci and Sun (2013) show that the Nash solution is invariant when threat  $s$  and/or feasible set  $W$  are changed in certain ways; last but not the least Van Damme (1986); Binmore et al. (1986); Howard (1992); Trockel (2002) show that the Nash solution is the Nash equilibrium of some non-cooperative bargaining games.

Despite its many appealing properties, the Nash solution has also been controversial. First, its objective function, the product of two utility numbers  $(v_1 - s_1)(v_2 - s_2)$ , does not have a straightforward interpretation (Rubinstein et al., 1992); Second, Axiom IIA

---

1. That is for both players solution  $v$  should be better than  $(\frac{s_1 + \max_{w \in W} w_1}{2}, \frac{s_2 + \max_{w \in W} w_2}{2})$ .

(Independent of Irrelevant Alternatives) of the Nash solution says that suppose  $v$  is the solution, if we remove some other options,  $v$  should remain to be the solution. While Axiom IIA suggests that there is some intrinsic reason such that  $v$  is selected as the solution, its implications are disturbing. Mathematically, the Nash solution only depends on  $v$ 's local property; economically, it implies for the purpose of comparing two solution candidates, all other options do not matter. Luce and Raiffa (1965) offer more detailed criticisms on Axiom IIA. Last, we would like to add that there are examples where the Nash solution clearly clashes with our common sense. Consider the following one.

**Example 1.** Hulk and Betty negotiate how often they go hiking, biking, or do nothing. And their utilities are  $u = f^h u^h + f^b u^b + f^n u^n$  where  $u^h, u^b, u^n \in \mathbb{R}^2$ , and  $f^h, f^b, f^n \geq 0$  satisfying  $f^h + f^b + f^n = 1$  represent the frequencies of each activity. If they cannot reach an agreement, they simply do nothing and get utilities  $u^n$ . In terms of Nash's bargaining model, the feasible set of utilities  $W$  is the triangle area of  $u^h$ ,  $u^b$ , and  $u^n$  and the threat  $s$  is  $u^n$ .

Consider an instance where  $u^h = (2, 2)$ ,  $u^b = (1, 3)$  (Hulk's is 1 and Betty's is 3), and  $u^n = (0, 0)$ , as shown in Figure 1.1a. That is Hulk prefers hiking and Betty prefers biking. In this bargaining problem, the Nash solution is  $u^h$  i.e. Hulk and Betty should *always* go hiking. It is worth to point out that this is irrelevant with the fact that hiking gives the same the same utility. For example, even if  $u^h = (6, 2)$  and  $u^b = (3, 3)$  as shown in Figure 1.1b, the Nash solution is still  $u^h$ . In both cases, the Nash solution completely favors one player over the other. There is no compromise at all clashing with our common sense.

Despite the controversies of the Nash solution, it has gained more consensus in literature



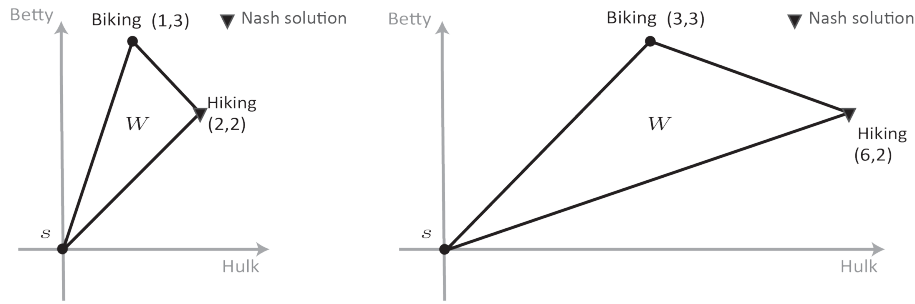

Figure 1.1: Hiking v.s. Biking

than other solutions and is the the main focus of bargaining theory and applications. By no means this implies that other solutions, including the Raiffa-Kalai-Smorodinsky solution (Raiffa, 1953; Kalai and Smorodinsky, 1975), the continuous Raiffa solution (Raiffa, 1953; Livne, 1989; Peters and Van Damme, 1991), the Equal Area solution (Dekel, 1982; Ritz, 1985; Anbarci and Bigelow, 1994), and the Supper-Additive solution (Perles and Maschler, 1981),<sup>2</sup> are less convincing than the Nash solution. In fact, in our view, they all are intuitively appealing. For example, the axiom of the Raiffa-Kalai-Smorodinsky that is employed to replace Axiom IIA of the Nash solution says this: given every feasible utility of one player, if the maximum feasible utility of the other player becomes weakly larger, then the utility of the other player given by the solution should also weakly larger. However, one one hand, these solutions are quite different from the Nash solution, which is reflected by the fact that their key axioms are very different from Axiom IIA. As a result, it is not clear how to precisely compare them and further make a trade-off. On the other hand, due to the fundamental contribution of Nash (1950) and its simplicity, the Nash solution has magnetic-

2. Bargaining solutions can be classified into two types depending on if there are interpersonal comparison of utilities. In the main context, we do not list solutions that impose interpersonal comparison of utilities e.g. Utilitarian solution and Egalitarian solution.

likely attracted much attention, which has led to discoveries of its many appealing properties; and these discoveries in turn further reinforce the Nash solution's attraction. To advance our understanding of bargaining, it seems necessary to have a solution that can guide us out of the Nash solution's magnetic force, a solution that can be precisely compared with the Nash solution and help us make a trade-off.

One mission of this paper is to provide such a new solution: the Consensus solution. The Consensus solution achieves this mission by delicately being different but not too different from the Nash solution.

On one hand, the Consensus solution is different from the Nash solution such that it can overcome the Nash solution's major controversies. First, it maximizes the total amount of options that both players agree are worse than the solution but better than no-cooperation (Problem 1.1). Therefore, it bears a straightforward interpretation of maximizing the consensus of players. Second, it satisfies all the axioms of the Nash solution except the controversial Axiom IIA (Independence of Irrelevant Alternatives); in contrast, the Nash solution satisfies all its axioms except one (Axiom 6) which says: when both players' utilities of no-cooperation become lower creating additional room for players to cooperate, then as long as the options in the additional room are worse than the current solution, the solution shall not change. Third, the Consensus solution is not as extreme as the Nash solution in bargaining problems like the one between Betty and Hulk because it can additionally capture the cooperative aspects of a bargaining problem: although Betty and Hulk have a conflicting interest between biking and hiking, they both are better off doing something instead nothing.

On the other hand, the Consensus solution is closely related with the Nash solution such that it can inherit the appealing properties of the Nash solution. In terms of axioms,

it satisfies not only all the axioms of the Nash solution except Axiom IIA but also part of Axiom IIA in the following sense. Specifically, we decompose Axiom IIA into several subaxioms (Axioms 4, 5, and 6N). Among them, there is only one axiom (Axiom 6N) that the Consensus solution does not satisfy. The rest axioms are enough to characterize the Nash solution in *comprehensive* bargaining problems (Theorem 2c),<sup>3</sup> where most of the appealing properties of the Nash solution are discovered. Since the Consensus solution also satisfies the rest axioms, it is the same as the Nash solution in comprehensive bargaining problems and correspondingly inherit these appealing properties of the Nash solution.

The bargaining theory after Nash (1950) gradually focuses on comprehensive bargaining problems due to the idea of free disposal of utilities. Specifically, by free disposing players' utilities, one can always transform a non-comprehensive bargaining problem into a comprehensive one. At first glance, it appears a reasonable idea but careful investigations are needed to reach a conclusion. In Nash's bargaining model, utilities are only representations of players' preferences. They do not exist therefore cannot be directly free disposed. Although physical resources can be freely disposed, it does not necessarily mean that utilities can be *independently* "free disposed." For example, two players' utilities may be  $u_1 = x_1$  and  $u_2 = \frac{x_1}{2} + x_2$  where  $x_1$  and  $x_2$  represent how much resources they get. Here, free disposing  $x_1$  decreases both players utility. Furthermore, the bargaining matter may not even be about resources (see Example 1). Of course, one can assume that, on top of the bargaining matter, there are physical resources that can independently affect players' utilities. But on one hand, one essentially consider another bargaining problem instead of what we are originally

---

3. A bargaining problem  $(W, s)$  is *comprehensive* if for any  $v \in W$  and  $w \in \mathbb{R}^2$ ,  $s \leq w \leq v$  implies  $w \in W$ .

interested in; on the other hand, this assumption may be invalid because there are bargaining situations where there do not exist additional physical resources. We give detailed examples in section 1.2.3.

While the Consensus solution inherits the appealing properties of the Nash solution and overcomes some of its controversies, by no means we regard the Consensus solution as ideal. It still bears some of the criticisms on Axiom IIA (mainly due to Axiom 5). But completely discarding Axiom IIA would be a too big step and have the risk of adding confusions on top of those we already have in bargaining theory. We would like to progressively move forward and the Consensus solution can serve as a stepstone along the way. Therefore, in this paper we propose the Consensus solution and compare it with the Nash solution; in our companion paper, we propose another solution and compare it with the Consensus solution.

Now we shall move to the main context and formally introduce the Consensus solution.

## 1.2 Maximization

We consider the same bargaining problem  $(W, s)$  (see above Definition 1) as in Nash (1950) and maintain the same assumptions:  $W$  is compact and convex and  $s \in W$ . Compactness is a technical assumption. In the context of von Neumann-Morgenstern utility, the availability of randomization is sufficient for convexity. In Nash (1950),  $s \in W$  is assumed because  $s$  can be obtained by two players jointly triggering the threat.

Before moving on, we need a few notations.

- $v \geq w$  if  $v_1 \geq w_1, v_2 \geq w_2$ ;
- $v \succ w$  if  $v \geq w$  and  $v \neq w$ ;

- $v \in W$  is an *efficient point* of  $W$  if there is no other  $w \in W$  such that  $w \succeq v$  and we denote the set of all efficient points as  $E(W)$ ;
- $\mu(W)$  is the area of set  $W$ .

### 1.2.1 The Consensus Solution

We define *the Consensus solution of the bargaining problem*  $(W, s)$  as the solution(s) of the following maximization problem

$$\max_{v \succeq s, v \in E(W)} \mu(\{w \in W | s \leq w \leq v\}). \quad (1.1)$$

To interpret problem (1.1), consider all the points within  $W$ . Using threat  $s$ , we can classify them into two types: *Individually Irrational points*  $I(W, s) \equiv \{w \in W | w_1 < s_1 \text{ or } w_2 < s_2\}$  and *Individually Rational points*  $R(W, s) \equiv \{w \in W | w \geq s\}$ . The former are, for at least one player, strictly worse than  $s$  and in problem (1.1), they do not matter in any way. Given a solution candidate  $v \in E(W)$ , the latter can be classified into three types as shown in Figure 1.2a:  $C(W, s, v) \equiv \{w \in W | w \leq v\} \cap R(W, s)$ , *Consensus points* of  $v$ ;  $B_1(W, s, v) \equiv \{w \in W | w_1 > v_1, w_2 \leq v_2\} \cap R(W, s)$ , player 1's *Bargaining points* of  $v$ ; and  $B_2(W, s, v) \equiv \{w \in W | w_1 \leq v_1, w_2 > v_2\} \cap R(W, s)$ , player 2's *Bargaining points* of  $v$ .

$C(W, s, v)$  contains all options which, *both* players agree, are better than  $s$  but worse than  $v$ . It is exactly  $\{w \in W | s \leq w \leq v\}$ , the measure of which problem (1.1) maximizes. Thus, the Consensus solution of  $(W, s)$  can be interpreted as maximizing players' consensus.

$B_1(W, s, v)$  and  $B_2(W, s, v)$  are alternatives that are for one player strictly better than  $v$  but worse for the other. Particularly,  $B_1(W, s, v)$  contains options that player 1 prefers to  $v$ .

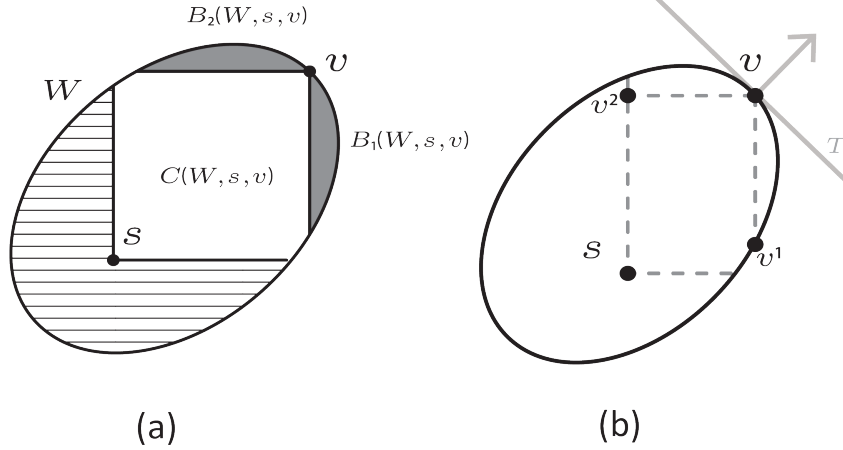

Figure 1.2: Notations

The larger it is, the lower  $v_1$ , the more dissatisfied player 1 is with  $v$ . Similarly,  $B_2(W, s, v)$  can measure player 2's dissatisfaction. the Consensus solution can also be interpreted as minimizing players' total dissatisfaction. To see this, notice that  $\mu(C(W, s, v)) = \mu(R(W, s)) - \mu(B_1(W, s, v)) - \mu(B_2(W, s, v))$ . Thus, problem (1.1) is equivalent to

$$\min_{v \geq s, v \in E(W)} \mu(B_1(W, s, v)) + \mu(B_2(W, s, v)). \quad (1^{\min})$$

## 1.2.2 Characterization

Now we provide the characterization results of the Consensus solution.

**Theorem 1.** *Suppose  $W$  is convex and compact and  $s \in W$ .*

(a). *There exists a unique solution of problem (1.1).*

(b). *If there is only a unique efficient point in  $(W, s)$  that is individually rational, i.e.  $E(R(W, s))$  is a singleton, the solution of problem (1.1) is  $E(R(W, s))$ ; if  $E(R(W, s))$  is not a singleton,  $v$  is a solution of problem (1.1) if and only if there exists a outward normal*

vector  $n = (n_1, n_2)$  of  $W$  at  $v$  such that

$$\frac{|vv^1|}{|vv^2|} = \frac{n_1}{n_2}. \quad (1.2)$$

where, as shown in Figure 1.2b, point  $v^1$  is the other intersection of the boundary of  $R(W, s)$  and the vertical line passing  $v$  and similarly  $v^2$  is the other intersection of the boundary of  $R(W, s)$  and the horizontal line passing  $v$ . Moreover,  $|vv^1|, |vv^2| > 0$ .

Theorem 1 is foundational to this paper. It not only gives the characterization results of the Consensus solution but also is important to discover and prove the axiomatic characterization in next section.

In Theorem 1, equation (1.2) is essentially the first order condition of problem (1.1). This equation can also be stated geometrically as: line  $v^1v^2$  and supporting line  $T$  that corresponds to normal vector  $n$  are in parallel.

To prove Theorem 1, we rewrite problem (1.1) as  $\max_{v \in E(R(W, s))} \mu(\{w \in R(W, s) | w \leq v\})$ . Clearly, we just need to show the case where  $E(R(W, s))$  is not a singleton. For this case,  $R(W, s)$  must be full-dimensional i.e.  $\mu(R(W, s)) > 0$ . Therefore, we can replace the constraint  $v \in E(R(W, s))$  with  $v \in R(W, s)$ . Then it is convenient to consider a more general problem as shown below.

$$\max_{v \in W} \mu(\{w \in W | w \leq v\}). \quad (1.3)$$

Now we state the characterization results of problem (1.3) in below Lemmas 1-3. For the purpose of Theorem 1 (the part where  $E(R(W, s))$  is not a singleton), we just need to apply

them with set  $R(W, s)$ .

**Lemma 1. *Existence:*** For any compact set  $W \subset \mathbb{R}^2$ , problem (1.3) has a solution.

**Lemma 2. *First Order Condition:*** Suppose  $W$  is convex, compact, and full dimensional ( $\mu(W) > 0$ ), and  $E(W)$  is not a singleton. Then  $v$  is a solution of problem (1.3) if and only if there exists a outward normal vector  $n = (n_1, n_2)$  of  $W$  at  $v$  such that equation (1.2) holds. Moreover,  $|vv^1|, |vv^2| > 0$ <sup>4</sup> and  $\mu(\{w \in W | w \leq v\})$  first weakly increases then weakly decreases as  $v$  moves along  $E(W)$  from left to right.

Before stating Lemma 3, we need to define a type of bargaining sets. Suppose  $W$  is convex, compact, and full dimensional. If there exists a nontrivial interval  $I \subset E(W)$  and a line  $L$  parallel with  $I$  such that for any  $v \in I$ , its corresponding  $v^1, v^2 \in L$ , we then call such  $W$  as an *Odd Bargaining set*. An example of an Odd Bargaining set is the convex hull of points  $a = (2, 0)$ ,  $b = (2, 1)$ ,  $c = (1, 2)$ , and  $d = (0, 2)$ , where  $I$  is interval  $bc$  and  $L$  is line  $ad$ .

**Lemma 3. *Uniqueness:*** Suppose  $W$  is convex, compact, and full dimensional. Problem (1.3) has multiple solutions if and only if  $W$  is an *Odd Bargaining Set*.

We leave the formal proofs of Lemmas 1-3 in Appendix 1.6.2 and sketch their intuitive ideas here. For Lemma 1, we just need to show the objective function in problem is continuous with respect to  $v$  and then the existence follows from Weierstrass's extreme value theorem.

For Lemma 2, to show that  $v$  is a solution of problem (1.3) implies equation (1.2) holds, we compare the area of  $\{w \in W | w \leq v\}$  with  $\{w \in W | w \leq v'\}$  where  $v'$  is an efficient point right to  $v$ . As shown in Figure 1.3a, the increment and decrement are the areas of sets

---

4.  $v^1, v^2$  are defined the same way in Theorem 1 but with respect to set  $W$  instead of  $R(W, s)$ .



$v'v'^1v^1v^x$  and  $vv^2v'^2v^x$  respectively, where  $v'^1$  and  $v'^2$  are defined similarly as  $v^1$  and  $v^2$  and  $v^x$  is the intersection of intervals  $vv^1$  and  $v'v'^2$ . Therefore, when  $v'$  and  $v$  are close enough, they are approximately  $|v'_1 - v_1||vv^1|$  and  $|v'_2 - v_2||vv^2|$  and  $\frac{|v'_2 - v_2|}{|v'_1 - v_1|} \approx \frac{n_1}{n_2}$  for some normal vector  $n$  at  $v$ . Thus we must have

$$\begin{aligned} \mu(\{w \in W | w \leq v'\}) - \mu(\{w \in W | w \leq v\}) &\approx |v'_1 - v_1||vv^1| - |v'_2 - v_2||vv^2| \\ &\approx |v'_1 - v_1||vv^2| \left( \frac{|vv^1|}{|vv^2|} - \frac{n_1}{n_2} \right). \end{aligned}$$

Therefore,  $v$  is a solution of problem (1.3) implies equation (1.2) equation (1.2) holds. To finish the rest of Lemma 2, we just need to prove  $\frac{|vv^1|}{|vv^2|} - \frac{n_1}{n_2}$  weakly decreases as  $v$  moves along  $E(W)$  from left to right. The second term  $\frac{n_1}{n_2}$  weakly increases because  $W$  is convex. The first term must weakly decrease since it is equal to the slope of line  $v^1v^2$  and as shown in Figure 1.3b, line  $v^1v^2$  must be weakly steeper than line  $v'^1v'^2$  because  $v, v'^1, v^1,$  and  $v^2$  are extreme points of  $W$ , which in turn must be weakly steeper than line  $v'^1v'^2$  for a similar reason.

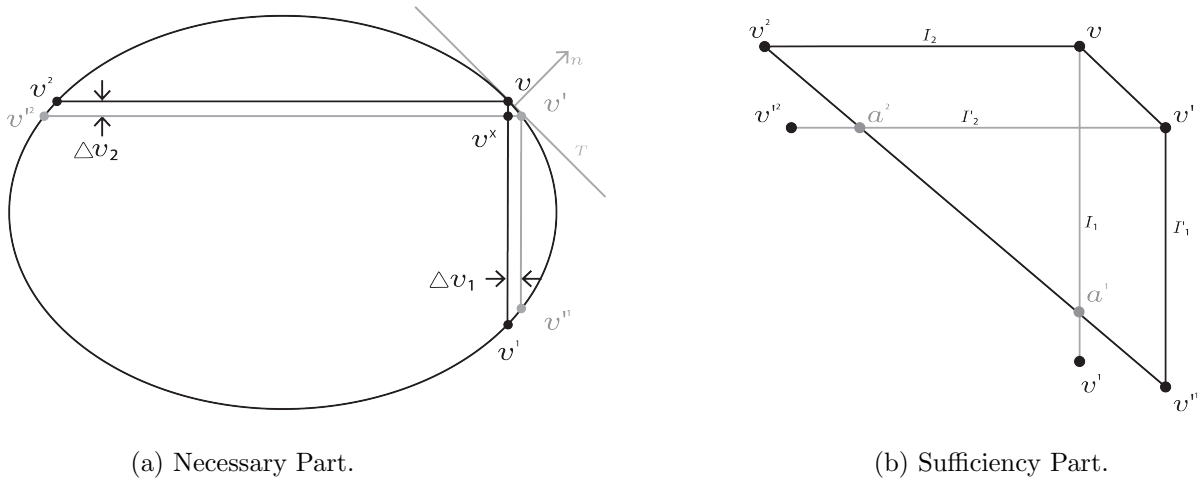

Figure 1.3: Illustration of the Proof of Lemma 2.

For Lemma 2, if  $W$  is an Odd Bargaining set, Lemma 2 immediately implies the corresponding

interval  $I$  of  $W$  are solutions of problem (1.3); if problem (1.3) has multiple solutions, we show  $W$  must be an Odd Bargaining set according to its definition i.e. there exists corresponding interval  $I$  and line  $L$ , which we prove by respectively showing for different solution  $v$ ,  $\frac{n_1}{n_2}$  of equation (1.2) has to be the same and  $\frac{|vv^1|}{|vv^2|}$  also has to be the same. Appendix 1.6.3 contains the details of this proof.

Applying Lemmas 1 and 2 with set  $R(W, s)$ , we immediately get the existence and equation (1.2) in Theorem 1. To get the uniqueness result in Theorem 1, according to Lemma 3, we just need to show that  $R(W, s)$  is not an Odd Bargaining set, which has to be true because  $s \leq w$  for any point  $w \in R(W, s)$  but in an Odd Bargaining set, there cannot exist such point  $s$ .

### 1.2.3 Comparison with the Nash solution

It is well-known that the Nash solution is the solution of the below problem

$$\max_{v \geq s, v \in E(W)} (v_1 - s_1)(v_2 - s_2).$$

To contrast the Nash and Consensus solutions, we rewrite it as below, reprint problem (1.1), and illustrate them in Figure 1.4:

$$\max_{v \geq s, v \in E(W)} \mu(\{w \in \mathbb{R}^2 | s \leq w \leq v\}); \tag{1N}$$

$$\max_{v \geq s, v \in E(W)} \mu(\{w \in W | s \leq w \leq v\}). \tag{1}$$

For problem (1N), we have the following theorem.

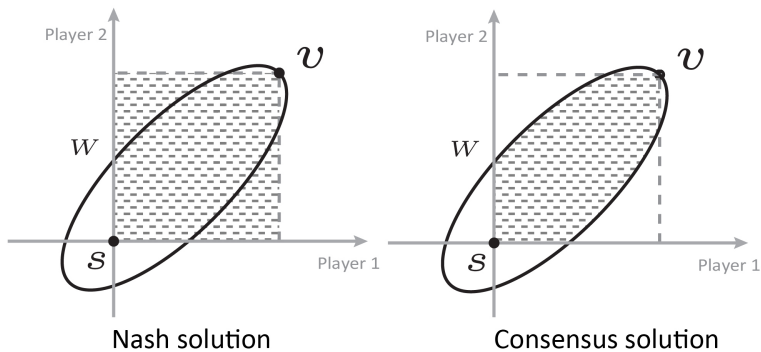

Figure 1.4: The areas that the Nash and Consensus solutions maximize.

**Theorem 1N.** <sup>5</sup> Suppose  $s \in W$  and  $W$  is convex and compact.

(a). There exists a unique solution of problem (1N).

(b). If there is only a unique efficient point in  $(W, s)$  that is individually rational, i.e.  $E(R(W, s))$  is a singleton, the solution of problem (1.1) is  $E(R(W, s))$ ; if  $E(R(W, s))$  is not a singleton,  $v$  is a solution of problem (1.1) if and only if there exists a outward normal vector  $n = (n_1, n_2)$  of  $W$  at  $v$  such that

$$\frac{|va^1|}{|va^2|} = \frac{n_1}{n_2} \quad (2N)$$

where points  $a^1 \equiv (v_1, s_2)$  and  $a^2 \equiv (s_1, v_2)$ .

Equations (1N) and (1) suggest that for the Consensus solution, its desirability solely depends on the options within  $W$  whereas for the Nash solution, it may depend on options outside  $W$ . Such difference in dependence on  $W$  is again revealed in their characterizing equations (1.2) and (2N). The two equations' right sides are exactly the same and about the local information of  $W$  at  $v$ ; their left sides are different. The left side of equation (1.2), it

---

5. The contents of this theorem are known and simple to prove. Thus, we omit its proof.

is  $\frac{|vv^1|}{|vv^2|}$  depending on points ( $v^1$  and  $v^2$ ) in  $W$  whereas the left side of equation (2N) is  $\frac{|va^1|}{|va^2|}$  where  $a^1$  and  $a^2$  may be outside of  $W$ .

Now we revisit Example 1 we introduce in last section. With the help of equation (1.2), we can obtain its Consensus solution:  $(\frac{8}{5}, \frac{12}{5})$ . In terms of physical actions, the Consensus solutions means that they go biking 40% of the time and go hiking 60% of the time, which is much more moderate than Nash solution.

Despite their difference, the two solutions are the same in comprehensive bargaining problems. To see this, notice that for a comprehensive bargaining problem  $(W, s)$ , all points  $w$  satisfying  $s \leq w \leq v$  are within  $W$ . Therefore, equations (1N) and (1) coincide thus the two solutions must be the same.

In literature, comprehensive bargaining problems are widely studied because of the idea that one can always transform a non-comprehensive bargaining problem into a comprehensive one by *independently* free disposing players' utilities. This idea appears reasonable but careful investigations are needed to reach a conclusion. *First*, in Nash's bargaining model, utilities are only representations of players' preferences, they do not really exist and therefore cannot be free disposed. *Second*, what may be free disposed are physical resources. However, on one hand, the bargaining matter may not be about resources (see Examples 1 and 2a); on the other hand, even when the bargaining matter is about resources, independently free disposing players' resources is neither sufficient nor necessary (Examples 2b and 2c). *Last*, surely one can transform a non-comprehensive bargaining problem to a comprehensive one by including from outside of the bargaining matter resources that can independently affect players' utilities. However, on one hand, since these resources have nothing to do with the bargaining matter, it is questionable that such inclusion is the right description of real

bargaining situations and what players would like to subscribe to; on the other hand, there are situations where there are no outside resources to be included at all because all physical resources have already been included (Examples 2d and 2e). Of course, sometimes we do consider some form of free disposal like money burning (e.g. , Spence, 1978; Van Damme, 1989), but they are in strategic models with incomplete information where free disposal serves as a signal or communication device and shall not be confused with Nash’s cooperative model with complete information where bargaining is to argue cases that favor instead of oppose their interests.

**Example 2.** (a). **Coordination of Actions** Two countries need to coordinate (e.g. on climate change) which action to take from  $n$  options, under which their utilities are  $u^1, u^2, \dots, u^n \in \mathbb{R}^2$ . If they cannot agree which action to take, they get utilities  $u^0$ . In terms of Nash’s bargaining model,  $W$  is the convex hull of points  $u^0, u^1, \dots, u^n$  and  $s$  is  $u^0$ . Here  $(W, s)$  is non-comprehensive unless  $u^0$  is correlated with other actions in a specific manner, as shown in below,

$$u_1^0 \geq \min_{k \in A_2} u_1^k \text{ where } A_2 = \operatorname{argmax}_{k=1,2,\dots,n} u_2^k;$$

$$u_2^0 \geq \min_{k \in A_1} u_2^k \text{ where } A_1 = \operatorname{argmax}_{k=1,2,\dots,n} u_1^k.$$

(b). **Allocation of Resources** Two brothers have 2 million dollars to inherit. Their utilities are  $u_1 = x_1$  and  $u_2 = \frac{x_1}{2} + x_2$  where  $x_1$  and  $x_2$  represent how much money they get. They need to agree how to split the money subject to  $x_1 + x_2 \leq 2$ ; otherwise, they get nothing.  $W$  is the triangle area of points  $(0, 0)$ ,  $(0, 2)$  and  $(2, 1)$  and threat  $s$  is  $(0, 0)$ . Here, although we assume free disposal of money,  $(W, s)$  is not comprehensive.

(c). **Exchange of Goods** Two players derive their utilities from consuming two goods:

apple and banana. Their utilities are  $u_1(x_1^A, x_1^B) = 2x_1^A + x_1^B$  and  $u_2(x_2^A, x_2^B) = x_2^A + 2x_2^B$  where  $x_1^A$  and  $x_1^B$  stands for player 1's consumption of apple and banana; similar for  $x_2^A$  and  $x_2^B$ . Denote their total endowments of the goods are  $(3, 3)$ . Following the standard setup in Edgeworth's box,  $x_1^A + x_2^A = 3$  and  $x_1^B + x_2^B = 3$ . In terms of Nash's bargaining model,  $W$  is the quadrilateral  $(0, 9)$ ,  $(6, 6)$ ,  $(9, 0)$ , and  $(3, 3)$ ,  $s$  is their utilities before the exchange. Notice that although we do not assume free disposal of goods,  $(W, s)$  is comprehensive regardless the position of threat  $s$ .

(d). **Wage Negotiation** Labor union and management negotiate how to split 1 unit profits. Their utilities are respectively  $u_L = w$  and  $u_M = 1 - w$  where  $w \geq 0$  represents the wage. If no agreement, an strike happens, labor union gets nothing and management suffers 1 loss due to fixed cost i.e.  $u_L = 0$ . In terms of Nash's bargaining model,  $W$  is the triangle  $(1, 0)$ ,  $(0, 1)$ , and  $(0, -1)$  (the first coordinate represent union's utility) and  $s$  is  $(0, -1)$ .  $(W, s)$  is non-comprehensive. And the Nash solution sets  $w = 1$ .

(e). **Marriage Problem** Two partners are married. Their utilities are  $u_1 = c_1 + l_1$  and  $u_2 = c_2 + l_2$  where  $c_1, c_2 \geq 0$  represent their consumption satisfying  $c_1 + c_2 \leq a$  ( $a > 0$  is their total asset), and  $l_1, l_2 \geq 0$  represent the enjoyment that they obtain from the companionship. They need to decide how to allocate their consumption. If they cannot reach an agreement, divorce happens and their consumption is  $(a_1, a_2)$  dictated by law satisfying  $a_1 + a_2 = a$ . Triangle  $M$  of points  $(l_1, l_2 + a)$ ,  $(l_1 + a, l_2)$ , and  $(l_1, l_2)$  represents what utilities they can obtain within marriage. In terms of Nash's bargaining model,  $W$  is the convex hull formed by triangle  $M$  and point  $(a_1, a_2)$ , and  $s$  is  $(a_1, a_2)$ .  $(W, s)$  is non-comprehensive if either  $l_1 > a_1$  or  $l_2 > a_2$  holds.

### 1.3 Axiomatization

In above, we compare the Consensus and Compromise solutions within a single bargaining problem. In this section, we view them as functions of all the bargaining problems and compare the axioms that characterize them.

Let  $\mathbb{B}$  be a set of tuples  $(W, s)$  where  $W \in \mathbb{R}^2$  is convex and compact, and  $s$  is a point in  $W$ . Consider function  $V : \mathbb{B} \rightarrow \mathbb{R}^2$ . If for all  $(W, s) \in \mathbb{B}$ ,  $V(W, s) \in W$ , we then call  $V(\cdot)$  as a *solution* of bargaining problems.

In below, we present axioms that lead to the Consensus and Nash solutions. The two solutions share five axioms in common. This is connected with the result of last section—the common axioms are enough to identify them in comprehensive bargaining problems. Formally, we have the below theorem.

**Theorem 2.** (a). *A solution  $V(\cdot)$  of  $\mathbb{B}$  satisfies Axioms 1-5, and 6 if and only if for any  $(W, s) \in \mathbb{B}$ ,  $V(W, s)$  is the Consensus solution of  $(W, s)$  i.e. the solution of problem (1.1).*

(b). *A solution  $V(\cdot)$  of  $\mathbb{B}$  satisfies Axioms 1-5, and 6N if and only if for any  $(W, s) \in \mathbb{B}$ ,  $V(W, s)$  is the Nash solution of  $(W, s)$  i.e. the solution of problem (1N).*

(c). *A solution  $V(\cdot)$  of  $\mathbb{B}$  satisfies Axioms 1-5 if and only if for any comprehensive bargaining problem  $(W, s) \in \mathbb{B}$ ,  $V(W, s)$  is the Consensus (and Nash) solution of  $(W, s)$ .*

We introduce a few notations used in below axioms. We call a point  $w$  and a subset  $W$  of  $\mathbb{R}^2$  as *symmetric* if  $w_1 = w_2$  and  $W = \{(w_2, w_1) | w \in W\}$ , respectively. For given points  $c \in \mathbb{R}_{++}^2$ ,  $b \in \mathbb{R}^2$ , and  $w \in \mathbb{R}^2$ ,  $c \cdot w + b \equiv (c_1 w_1 + b_1, c_2 w_2 + b_2)$  and  $c \cdot W + b \equiv \{c \cdot w + b | w \in W\}$ . Here  $(c, b)$  represents a pair of order-preserving affine transformations of players' utilities. And  $W \setminus W' \equiv \{w \in W | w \notin W'\}$ .

**Axiom 1. Efficiency:** For any  $(W, s) \in \mathbb{B}$ ,  $V(W, s)$  is an efficient point of  $W$ .

**Axiom 2. Symmetry:** For any  $(W, s) \in \mathbb{B}$ , if both  $W$  and  $s$  are symmetric, then  $V(W, s)$  is symmetric.

**Axiom 3. Affine Invariance:** For any  $(W, s) \in \mathbb{B}$ , for any  $c \in \mathbb{R}_{++}^2$  and  $b \in \mathbb{R}^2$ ,  $V(c \cdot W + b, c \cdot s + b) = c \cdot V(W, s) + b$ .

Axioms 1-3 are used in Nash (1950). Axiom 1 is self-evident. Axiom 2 says that  $V(\cdot)$  shall be impartial. The subtext of Axiom 3 is that utilities are only representations of players' preferences therefore different representations shall not change the solution, just like one shall not feel colder if Celsius is used instead of Fahrenheit. Since the absolute values of utilities become meaningless, Axiom 3 effectively rules out interpersonal comparison of utilities.

**Axiom 4. -Irrational:** For any  $(W, s), (W', s) \in \mathbb{B}$ , if  $W \supset W'$  and  $W \setminus W'$  are Individually Irrational points of  $V(W, s)$ , then  $V(W', s) = V(W, s)$ .

**Axiom 5. -Bargaining:** For any  $(W, s), (W', s) \in \mathbb{B}$ , if  $W \supset W'$  and  $W \setminus W'$  are Bargaining points of  $V(W, s)$ , then  $V(W', s) = V(W, s)$ .

**Axiom 6. +Consensus:** For any  $(W, s), (W, s') \in \mathbb{B}$ , if  $s' \leq s$  and  $R(W, s') \setminus R(W, s)$  are Consensus points of  $V(W, s)$ , then  $V(W, s') = V(W, s)$ .

**Axiom 6N. (a). -Consensus:** For any  $(W, s), (W', s) \in \mathbb{B}$ , if  $W \setminus W'$  are Consensus points of  $V(W, s)$ , then  $V(W', s) = V(W, s)$ ;

(b). **Threat Reference:** For any  $(W, s), (W, s') \in \mathbb{B}$ , if  $s' \leq s$  and  $s'$  is on the same line with  $s$  and  $V(W, s) \neq s$ , then  $V(W, s') = V(W, s)$ .



Axioms 4, 5, and 6N can be seen as a decomposition of Axiom IIA used in Nash (1950). Using the same notations, we can state Axiom IIA as: For any  $(W, s), (W', s) \in \mathbb{B}$ , if  $W' \subset W$  and  $V(W, s) \in W'$ , then  $V(W', s) = V(W, s)$ . Clearly, Axiom IIA implies the Axioms 4, 5, 6Na. But the reverse does not hold because the three axioms say *independently* removing individually irrational points,  $V(W, s)$ 's Bargaining points, and  $V(W, s)$ 's Consensus points does not change the solution while the contents of Axiom IIA are much richer than its appearance and also covers cases of *jointly* removing them.

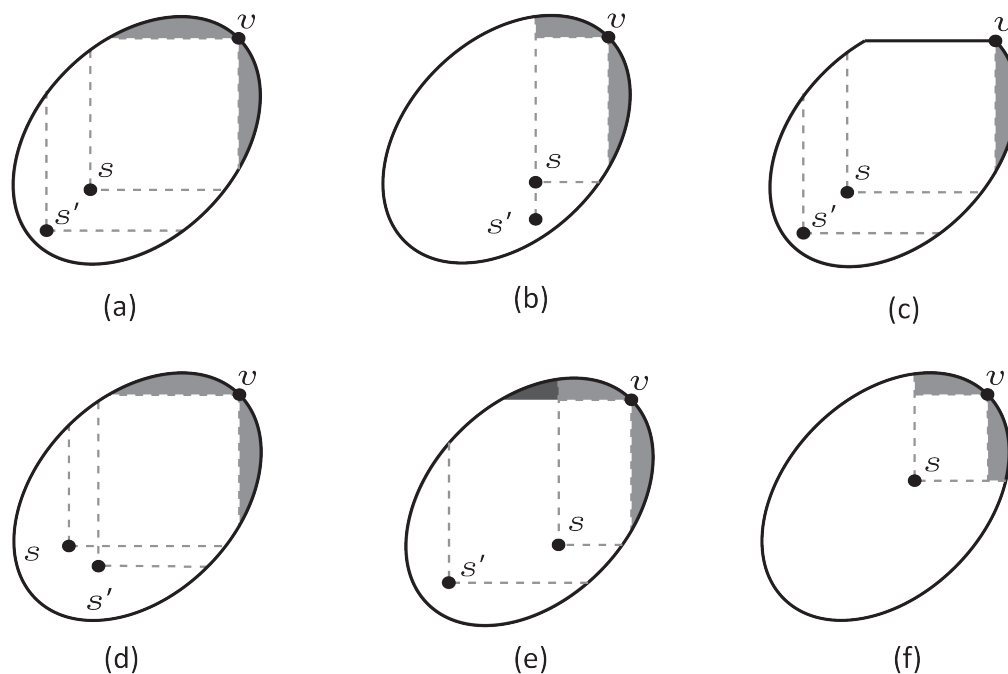

Figure 1.5: Subfigures (a), (b), and (c) are examples where Axiom 6 apply; Axiom 6 does not apply in Subfigures (d) because  $s' \leq s$  does not hold; Axiom 6 does not apply in Subfigures (e) because compared with  $R(W, s)$ ,  $R(W, s')$  also has more (Player 2's) Bargaining Points of  $v$  (shaded area); in Subfigure (f), there does not exist  $s' \neq s$  such that Axiom 6 can apply.

While Axioms 2-5 need further explanations, they have nothing to do with understanding the differences between the Consensus and Nash solutions, the main mission of this paper. Thus we leave these explanations to Section 1.5 and turn our main focus on Axioms 6 and 6N.

Axiom 6 says that when the threat becomes worse for both players ( $s' \leq s$ ), players have additional options to cooperate ( $R(W, s') \supset R(W, s)$ ), then as long as the additional options are worse than the current solution ( $R(W, s') \setminus R(W, s)$  are Consensus points), the solution shall not change. Put it in short, Axiom 6 says the case when the change of the threat induces *more Consensus points regardless the exact position* of the new threat. In comparison, Axiom 6N is almost the exact opposite of Axiom 6. Axiom 6Na says cases of *lessening Consensus points*; Axiom 6Nb says cases when the threat changes and the new threat is *at a certain position*: in the same line with the old threat and solution.

Now consider Axioms 6 and 6N in below examples.

**Example 3.** (a). Let  $s = (0, 0)$ ,  $a^1 = (1, 0)$ ,  $a^2 = (0, 2)$ , and  $v = (1, 1)$  as shown in Figure 1.6a. Denote  $sa^1va^2$  as  $W$ . Both the Nash and Consensus solutions of  $(W, s)$  are  $v$ .

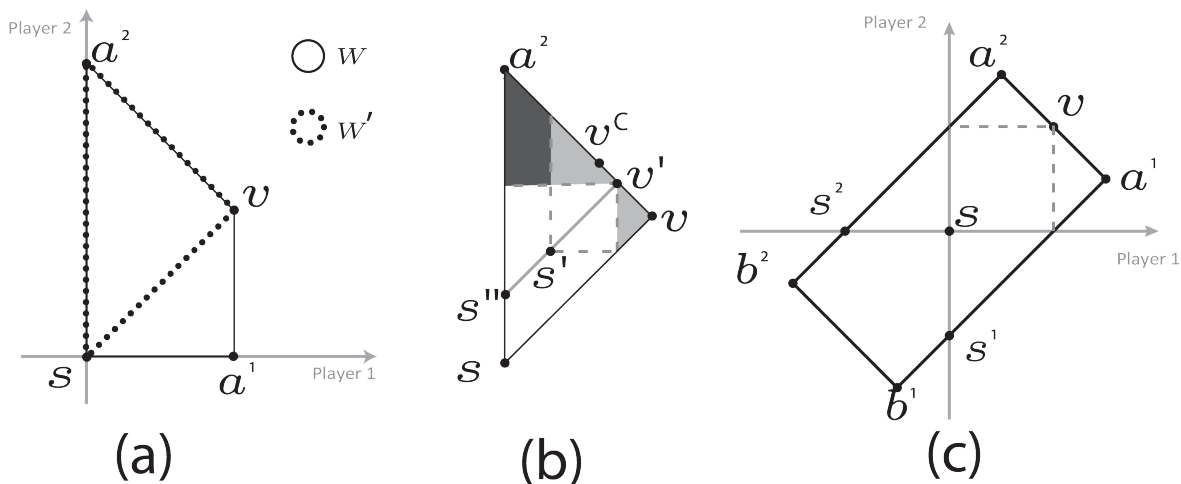

Figure 1.6: Nash Solution v.s. Consensus Solution (The detailed description is Example 3.)

Denote triangle  $sva^2$  as  $W'$ . Here  $W \setminus W'$  are Consensus points of  $v$ . For  $(W', s)$ , the Nash solution is still  $v$  satisfying Axiom 6Na; but the Consensus solution changes to  $v^C = (\frac{2}{3}, \frac{4}{3})$  thus violates Axiom 6Na.

(b). Consider  $W'$ , triangle  $sva^2$ , in part (a). Let  $s' = (\frac{1}{4}, \frac{3}{4})$  and  $v' = (\frac{1}{4}, \frac{3}{4})$ , as shown in Figure 1.6b. Both the Nash and Consensus solutions of  $(W', s')$  are  $v'$ .

Let  $s''$  be  $(0, \frac{1}{2})$ .  $s''$  is on line  $s'v'$ . For  $(W', s'')$ , the Nash solution is still  $v'$  satisfying Axiom 6Nb; but the Consensus solution changes to  $v^C = (\frac{2}{3}, \frac{4}{3})$  thus violates Axiom 6Nb.

(c). Let  $s = (0, 0)$ ,  $a^1 = (3, 1)$ ,  $a^2 = (1, 3)$ ,  $b^1 = (-1, -3)$ ,  $b^2 = (-3, -1)$  as shown in Figure 1.6c. Denote rectangle  $a^1a^2b^2b^1$  as  $W$ . Both the Nash and Consensus solutions of  $(W, s)$  are  $v = (2, 2)$ .

Consider  $(W, s^1)$ . Here  $R(W, s^1) \setminus R(W, s)$  are more Consensus points of  $v$ . The Consensus solution is still  $v$ ; but the Nash solution changes to  $a^1$  thus violates Axiom 6. Similarly in  $(W, s^2)$ .

In our view, the above three examples together with Axioms 6 and 6N reflect what matter more in determining the Consensus and Nash solutions. *For the Consensus solution, what two player can achieve via cooperation (Consensus and Bargaining points) matter more.* In Example 3a, the Consensus solution changes with lessening Consensus points; In Example 3b, the Consensus solution favors player 2 more in  $(W', s'')$  than in  $(W', s')$  with more player 2's Bargaining points (of  $v'$ ); In Example 3c, the Consensus solution does not change because Bargaining points do not change and there are more Consensus points. *For the Nash solution, what two player can achieve via no-cooperation (the threat) matters more.* In Examples 3a and 3b, the Nash solution does not change because the relative position of the threat does not change; in Example 3c, the Nash solution changes because the relative position of the threat changes.

We will continue to discuss such difference between the Nash and Consensus solutions

from other perspectives in next section. Before that, we present the proof of Theorem 2a.

Theorem 2b's proof is very similar and can be found in Appendix 1.6.4.

*Proof. If part:* If for any  $(W, s) \in \mathbb{B}$ ,  $V(W, s)$  is the solution of problem (1.1),  $V(\cdot)$  satisfies Axioms 1 -5.

*Axiom 1:*  $V(\cdot)$  clearly satisfies Axiom 1.

*Axiom 2:* Consider symmetric  $W$  and  $s$ .  $W$ 's has a unique symmetric efficient point. Denote it as  $v$ . We just need to show  $V(W, s) = v$ . That is to show that  $v$  is the solution of problem (1.1). If  $E(R(W, s))$  is a singleton, clearly  $v$  is the solution of problem (1.1). If not, due to the symmetry of  $W$ ,  $s$  and  $v$ , there exists a tangent line  $T$  of  $W$  at  $v$  with slope  $-1$  and  $v^1v^2$ 's slope is also  $-1$ . Thus equation (1.2) in Theorem 1 holds. Again,  $v$  is the solution of problem (1.1).

*Axiom 3:* Under order preserving affine transformations on utilities, the relative positions of points in  $W$  do not change. Specifically, if  $E(R(W, s))$  is a singleton, after the transformation, it is still a singleton; if  $E(R(W, s))$  is not a singleton, the parallel relationship between lines  $v^1v^2$  and tangent line  $T$  does not change, that is equation (1.2) in Theorem 1 still holds. In both cases, the relative positions of the solution of problem (1.1) do not change. Thus,  $V(\cdot)$  satisfies Axiom 3.

*Axiom 4:*  $V(\cdot)$  clearly satisfies Axiom 4.

*Axiom 5:* Since  $W'$  is a subset of  $W$ , for any  $v' \in E(W')$ , we have

$$\mu(\{w \in R(W, s) | w \leq v'\}) \geq \mu(\{w \in R(W', s) | w \leq v'\}).$$

Furthermore, since  $W \setminus W'$  are Bargaining points of  $V(W, s)$ , when  $v' = V(W, s)$ , two sides

of the above inequality are equal. Thus,  $V(W, s)$  must also solve problem (1.1) with  $(W', s)$ .

That is  $V(\cdot)$  satisfies Axiom 5.

*Axiom 6:* Since  $R(W, s') \setminus R(W, s)$  are Consensus Points of  $v \equiv V(W, s)$ , we have  $E(R(W, s')) = E(R(W, s))$  and  $\mu(\{w \in R(W, s') | w \leq v\}) = \mu(\{w \in R(W, s) | w \leq v\}) + \mu(R(W, s') \setminus R(W, s))$ . So  $v$  must also solve problem (1.1) with  $(W, s')$ . Thus  $V(\cdot)$  satisfies Axiom 6.

**Only If part:** If  $V(\cdot)$  of  $\mathbb{B}$  satisfies Axioms 1 - 6, for any  $(W, s) \in \mathbb{B}$ ,  $V(W, s)$  is the solution of problem (1.1). Suppose  $v$  solves problem (1.1). We prove this part by showing  $V(W, s) = v$ .

If  $E(R(W, s))$  is a singleton, due to Axiom 1, we have  $V(R(W, s), s) = v$ . Also, due to Axiom 4, we have  $V(W, s) = V(R(W, s), s)$ . Thus  $V(W, s) = v$ .

If  $E(R(W, s))$  is a not singleton, we prove  $V(W, s) = v$  in below six steps and they are illustrated in Figure 1.7.

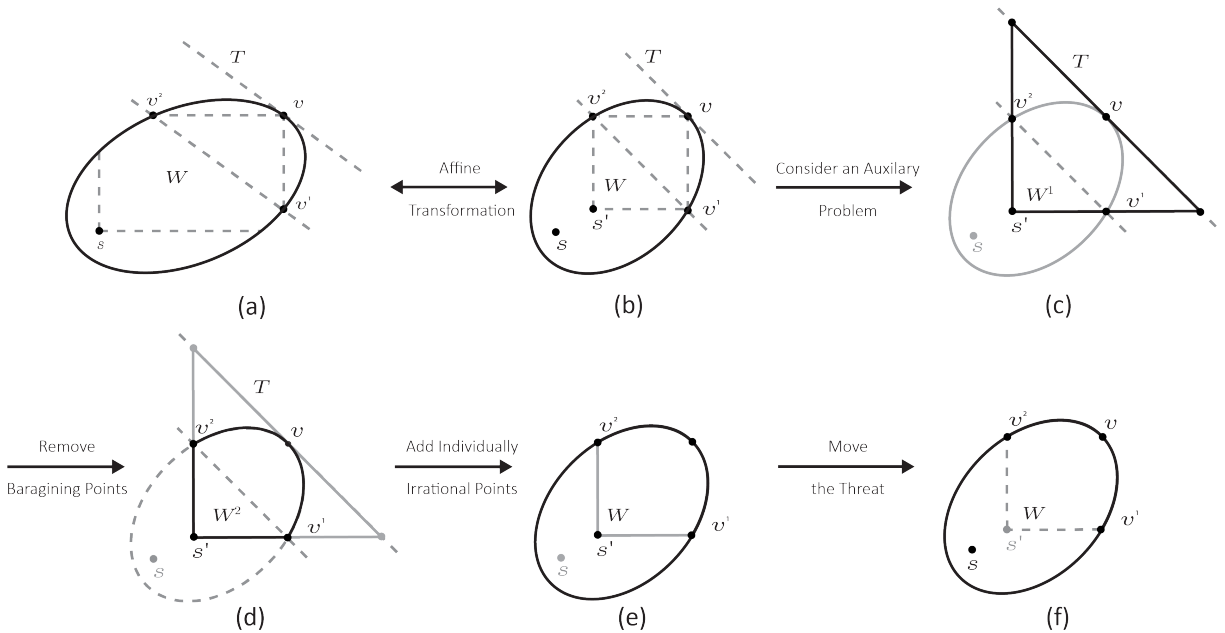

Figure 1.7: Proof of Theorem 2

(a) Since  $v$  solves problem (1.1), according to part (b) of Theorem 1, we have a supporting line  $T$  at  $v$  such that  $T$  is parallel with  $v^1v^2$ .

(b) Due to Axiom 3, it is equivalent to prove  $V(W, s) = v$  after order-preserving affine transformations on utilities. Implement affine transformations such that  $v$  becomes a symmetric point and  $T$ 's slope is  $-1$ . Line  $v^1v^2$ 's slope must also be  $-1$ . Thus  $|vv^1| = |vv^2|$ . Let  $s' \equiv (v_1^2, v_2^1)$ .  $s'$  must be symmetric.

Here we provide a few observations of  $s'$  that will be used in later steps: (1).  $s' \leq v$ ; (2).  $s \leq s'$  because  $s \leq v^1$  and  $s \leq v^2$ ; (3).  $s' \in W$  because  $s'$  is within triangle  $sv^1v^2 \subset W$ .

(c) Let  $W^1$  be the triangle area circumvented by lines  $T$ ,  $s'v^1$ , and  $s'v^2$ .  $W^1$  must also be symmetric. According to Axioms 1 and 2,  $V(W^1, s') = v$ .

(d) Due to observation (3) in step b,  $R(W, s')$  is well-defined. Denote it as  $W^2$ . Notice that  $W^1 \setminus W^2$  contains only Bargaining points of  $v$ . According to Axiom 5,  $V(W^2, s') = V(W^1, s') = v$ .

(e) Notice that for any  $W, s'$ ,  $R(W, s') = R(R(W, s'), s')$  i.e.  $R(W, s') = R(W^2, s')$ . According to Axiom 4,  $V(W, s') = V(W^2, s') = v$ .

(f) We already have  $s \leq s'$  (observation (2) in step b). According to Axiom 6,  $V(W, s) = V(W, s') = v$ , as desired, if we can further show that  $R(W, s) \setminus R(W, s')$  are Consensus points of  $v$ .

It is equivalent to show for any Bargaining point  $w \in R(W, s)$  of  $v$ ,  $w \geq s'$  i.e.  $w_1 \geq s'_1$  and  $w_2 \geq s'_2$ . Without loss of generality, suppose  $w$  is player 1's Bargaining point of  $v$ .

Thus  $w_1 > v_1$ . Also  $v_1 \geq s'_1$  (observation (1) in step b). So  $w_1 > s'_1$ . We prove  $w_2 \geq s'_2$  by contradiction. Suppose not,  $w_2 < s'_2$ . The locational relationship between  $v, s, w$  and  $v^1$  are:

- $v$  is strictly right above  $v^1$ ;
- $s$  is weakly below and strictly left to  $v^1$ ;
- $w$  is strictly below and right to  $v^1$  ( $w_2 < s'_2 = v_2^1$  and  $w_1 > v_1 = v_1^1$ ).

Thus  $v^1$  is an interior point of triangle  $vs w$ . A contradiction with  $v^1$  being an extreme point of  $R(W, s)$ .

■

## 1.4 Further Comparison

In last two sections, we have compared the Consensus and Nash solutions from perspectives of maximization and axiomatization. In this section, we further compare them from other perspectives.

### 1.4.1 Isosolution

As shown in Axioms 6 and 6N, one key difference between the Consensus and Nash solutions lies in the position of the threat. To further explore the meaning of the position of the threat, we consider all the possibilities of threat  $s$  within  $W$ . Formally, we introduce a new concept: *isosolution*. An *isosolution* of  $v \in E(W)$  is the set of threats that yield  $v$  as a solution in  $(W, s)$ .

Consider the  $W$  in Example 3c. Let  $v$  be any point on interval  $a^1a^2$ . As shown in Figure 1.8a, *its Nash isosolution is an interval*, the intersection of  $W$  and the line passing  $v$  with slope 1, which reflects Axiom 6Na. Whereas, its Consensus isosolution depends on the position of  $v$ , as shown in Figure 1.8a'. If  $v$  is above point  $(2, 2)$ , *its Consensus isosolution is a polyline with two segments*: the first segment's slope is 1 the same with the Consensus isosolution within triangle  $sa^1a^2$ ; the second segment is horizontal. When the threat moves from the first segment to the second segment, there are new individually rational points and they all are Consensus points of  $v$ , which reflects Axiom 6. If  $v$  is below point  $(2, 2)$ , it is the same with the exception that the second segment is vertical. If  $v$  is point  $(2, 2)$ , the second segment becomes the whole pentagon  $b^1s^1ss^2b^2$ . In Figures 1.8b and 1.8b', we also show the Nash and Consensus isosolutions when  $W$  is a unit disk. As Figure 1.8 shown, the Consensus and Nash solutions are the same when the threat is close to the efficient frontier of  $W$ , specifically, when the threat is at the first segment of the Consensus isosolution and the two solutions are usually different from each other when the threat is far away from the efficient frontier. To understand this further, we move to next section.

## 1.4.2 Situation of Bargaining

Now, we compare the Consensus and Nash solutions through understanding the situation of bargaining problem  $(W, s)$ .

**Situation of Bargaining Problem  $(W, s)$ :  $W$  part**      Since  $W$  can be completely characterized by its boundary  $\delta W$ , we can understand situation of  $W$  through  $\delta W$ . We need to introduce four sets.



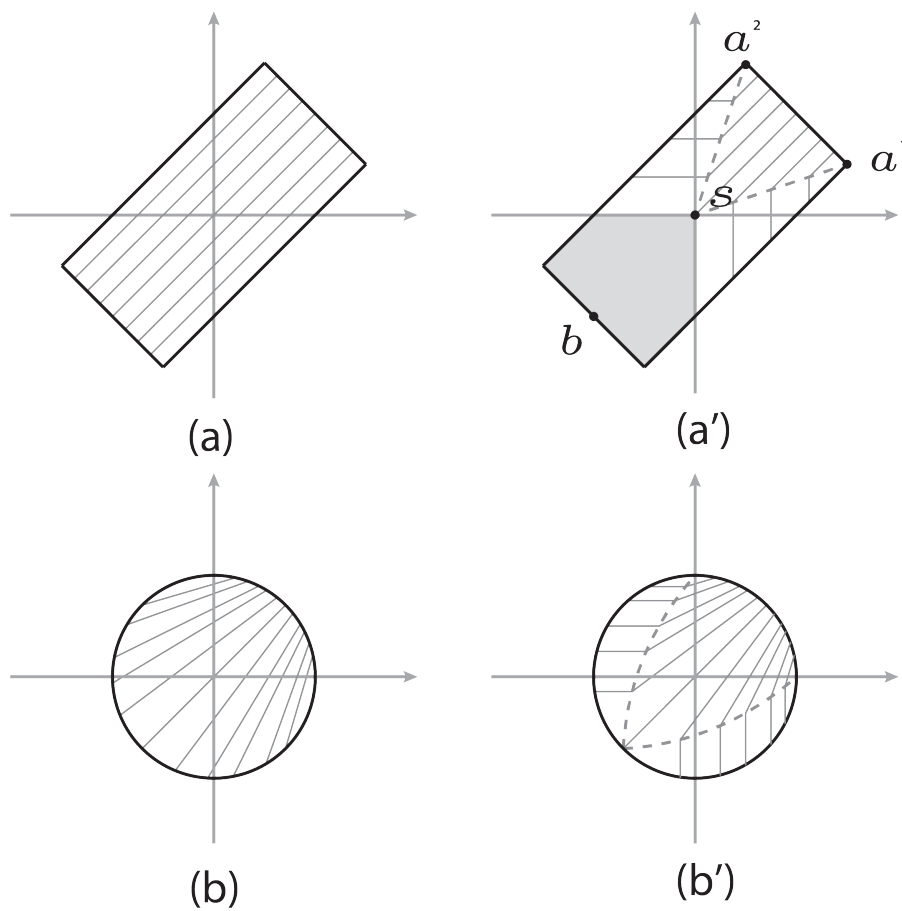

Figure 1.8: Isosolution: the set of threats that yield the same solution.

- $M_1 \equiv \{w \in W | w_1 = \max_{w' \in W, w'_2 = w_2} w'_1\}$  are the best choices for player 1 given player 2's utilities;
- $m_1 \equiv \{w \in W | w_1 = \min_{w' \in W, w'_2 = w_2} w'_1\}$  are the worst choices for player 1 given player 2's utilities;
- $M_2 \equiv \{w \in W | w_2 = \max_{w' \in W, w'_1 = w_1} w'_2\}$  are the best choices for player 2 given player 1's utilities;
- $m_2 \equiv \{w \in W | w_2 = \min_{w' \in W, w'_1 = w_1} w'_2\}$  are the worst choices for player 2 given player 1's utilities.

Now we can divide  $W$ 's boundary into the below eight contiguous segments, as shown in Figure 1.9.

- $M_1 \cap M_2$  represents “win-win” and is a downward-sloping curve;
- $m_1 \cap m_2$  represents “lose-lose” and is a downward-sloping curve;
- $M_1 \cap m_2$  represents “win-lose” and is a upward-sloping curve;
- $m_1 \cap M_2$  represents “lose-win” and is a upward-sloping curve;
- $A_1 \equiv \operatorname{argmax}_{w \in W} w_1$  represents “Win-” and is a vertical line;
- $a_1 \equiv \operatorname{argmin}_{w \in W} w_1$  represents “Lose-” and is a vertical line;
- $A_2 \equiv \operatorname{argmax}_{w \in W} w_2$  represents “-Win” and is a horizontal line;
- $a_2 \equiv \operatorname{argmin}_{w \in W} w_2$  represents “-Lose” and is a horizontal line;

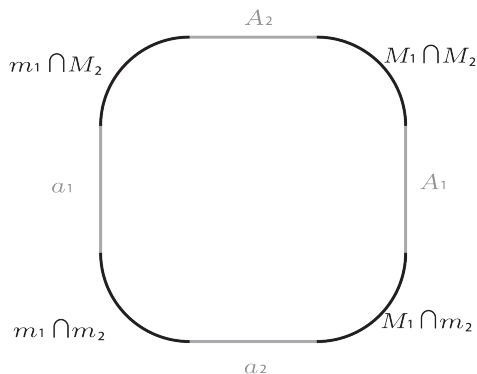

Figure 1.9: Situation of  $(W, s)$

$A_1$ ,  $a_1$ ,  $A_2$ , and  $a_2$  describe the situation of  $W$  from one player's perspective;  $M_1 \cap M_2$ ,  $m_1 \cap m_2$ ,  $M_1 \cap m_2$ , and  $m_1 \cap M_2$  are from two players' perspectives. Specifically,  $A_1$  and  $a_1$  are the best and worst choices for player 1; similarly,  $A_2$  and  $a_2$  are the best and worst choices for player 2;  $M_1 \cap M_2$  and  $m_1 \cap m_2$  feature the *non-cooperative* aspects of  $W$  because along them two players' interests are negatively correlated; whereas,  $M_1 \cap m_2$  and  $m_1 \cap M_2$  feature the *cooperative* aspects of  $W$  because along them two players' interests are positively correlated.

Since  $M_1 \cap M_2$ ,  $m_1 \cap m_2$ ,  $M_1 \cap m_2$ , and  $m_1 \cap M_2$  are from two players' perspectives, among the above eight sets, they are relatively more important in shape the situation. To better see this, consider examples in Figure 1.10. In them,  $W$  is a rectangle with the center at the origin and the slopes of its edges are  $-1$  and  $1$ . Denote the lengths of its edges along the two directions as  $l_n$  and  $l_c$ . They represent the strengths of non-cooperative and cooperative aspects of  $W$ . And Figures 1.10a-1.10c are examples where  $l_n > l_c$ ,  $l_n = l_c$ , and  $l_n < l_c$ . Clearly, players' interests are relatively more conflicting in Figure 1.10a and more consistent in Figure 1.10c. To be more precise, define a uniform probability over  $W$ , then correlation coefficients of two players utilities in Figures 1.10a-1.10c are respectively smaller than, equal

to, and bigger than 0. <sup>6</sup>

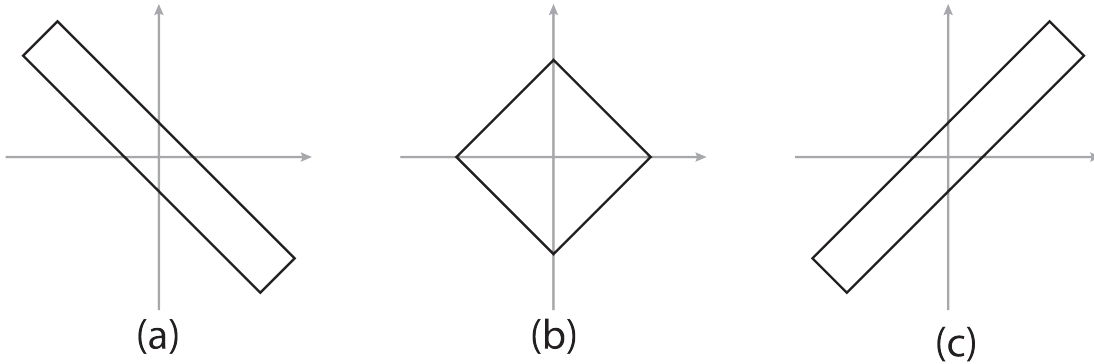

Figure 1.10: Situation of  $W$

(If we think of  $\delta W$  as a piece of music, the above eight sets are its basic notes. To hear them, run your finger along  $\delta W$  in Figures 1.9 and 1.10.)

**Situation of Bargaining Problem  $(W, s)$ :  $s$  part** Threat  $s$  *reshapes* the situation by classifying some points in  $W$  as individually irrational or rational. We simply call this classification as eliminating individually irrational points. To understand the reshaped situation, again, we can focus on the boundary of  $W$ : which part of  $\delta W$  is eliminated by  $s$ ? Or equivalently, which part remains?

Depending on the exact position of  $s$  in  $W$ , different parts of  $\delta W$  can be eliminated. But almost always, one whole non-cooperative segment,  $m_1 \cap m_2$ , is eliminated (except  $s$  itself when  $s \in m_1 \cap m_2$ ); always, part of the other non-cooperative segment,  $M_1 \cap M_2$ , remains; oftentimes, parts of the cooperative segments,  $m_1 \cap M_2$  and  $M_1 \cap m_2$ , remain;  $m_1 \cap M_2$  and  $M_1 \cap m_2$  are completely eliminated whenever the below two inequalities strictly hold

---

6. Notice that the correlation coefficients do not change under the affine transformation in Axiom 3.

(respectively).

$$\begin{aligned} s_1 &\geq \min_{w \in A_2} w_1; \\ s_2 &\geq \min_{w \in A_1} w_2. \end{aligned} \tag{1.4}$$

In next subsection, we use the above two inequalities to understand some bargaining situations of some economic problems even without having to explicitly write down what  $W$  and  $s$  are. We are able to do this because the two inequalities have straightforward interpretations. Each one of them tests if the threat is *empty or not* for some player by considering an extreme scenario. Suppose player 1 abstains from bargaining with player 2 except the right of triggering the threat. In  $W$ , clearly player 2 wants to choose from  $A_2$ , but will player 2 be able to freely choose without any concern? The answer is no if the first of inequalities (1.4) holds, that is, player 1's threat is *not empty*; no if it does hold. Similarly, the second inequality tests if player 2's threat is empty or not.

**The View from Situation of Bargaining Problem** ( $W, s$ )      Now we are ready to understand the differences of the Nash and Consensus solutions from the perspective of the situation of bargaining.

As shown in equation (2N), the Nash solution depends, except  $s$ , only on  $v$ ; whereas, as shown in equation (1.2), the Consensus solution, in addition, depends on  $v^1$  and  $v^2$ . Here,  $v$  is on  $M_1 \cap M_2$ ;  $v^1$  and  $v^2$  may be on  $M_1 \cap m_2$  and  $m_1 \cap M_2$ . Thus, the Nash solution only consider a non-cooperative aspect of  $W$ ; whereas, the Consensus solution *additionally* uses  $v^1$  and  $v^2$ , to detect the cooperative aspects of  $W$ .

Whether the cooperative aspects of  $W$  are detected by  $v^1$  or  $v^2$  is a sharp characterization of whether Consensus solution  $v$  is the Nash solution or not.

For Consensus solution  $v$ , if its corresponding  $v^1$  or  $v^2$  is on  $M_1 \cap m_2$  or  $m_1 \cap M_2$ , almost always,  $v$  is not the Nash solution. In Figures 1.8a and 1.8b, it is such case when the threat is outside of triangle  $a^1sa^2$  i.e. the threat is on the second segment of a Consensus isosolution. And as long as the threat is outside of triangle  $a^1sa^2$  and or not on interval  $sb$  where  $b = (-2, -2)$ ,  $v$  is not the Nash solution.

For Consensus solution  $v$ , if neither its corresponding  $v^1$  nor  $v^2$  is on  $M_1 \cap m_2$  or  $m_1 \cap M_2$ ,  $v$  is also the Nash solution. In Figures 1.8a and 1.8b, when the threat is within triangle  $a^1sa^2$  i.e. the threat is on the first segment of a Consensus isosolution. And as long as the threat is inside triangle  $a^1sa^2$ ,  $v$  is always the Nash solution. This can also be formally examined by the following two equations

$$\begin{cases} I_1(v) &= v_2 - s_2; \\ I_2(v) &= v_1 - s_1. \end{cases} \quad (1.5)$$

If neither its corresponding  $v^1$  nor  $v^2$  is on  $M_1 \cap m_2$  or  $m_1 \cap M_2$ , the above two equations hold and according to equations (1.2) and (2N),  $v$  must also be the Nash solution.

Furthermore, we speak intuitively when the Nash and Consensus solutions are different or the same from two perspectives:  $W$  and  $s$ . From the perspective of  $W$ : when the situation of  $W$  is mainly non-cooperative, its cooperative aspects are less likely to be detected and the Nash and Consensus solutions are less likely to be different; when  $W$  is mainly cooperative, its cooperative aspects are more likely to be detected and the Nash and Consensus solutions are more likely to be different. From the perspective of  $s$ : when  $s$  is far from  $W$ 's efficient frontier ( $M_1 \cap M_2$ ,  $W$ 's non-cooperative aspect), the two solutions are more likely to be different; when  $s$  is close to  $W$ 's efficient frontier, the two solutions are more likely to be the

same. We illustrate these (by comparing the Nash and Consensus isosolutions) in Figure 1.11 and conclude this subsection.

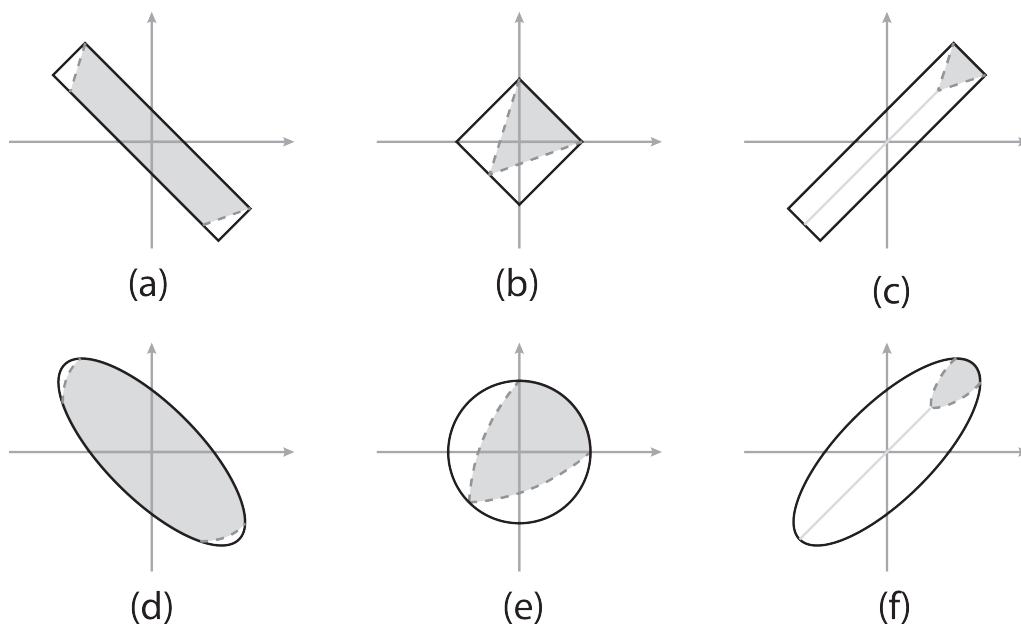

Figure 1.11: When the threat is in the grey area, the Nash and Consensus solutions are the same; otherwise, they are different.

### 1.4.3 Different Subjective Views

In above, we have stated the objective differences and similarities of the Nash and Consensus solutions. In below, we shall discuss the different subjective views behind them.

Behind the Nash solution, it is implicitly assumed that a solution is determined by an exogenous preference that, with the presence of the threat point, can evaluate options bilaterally. Thus for the purpose of comparing two options, except the threat all other options do not matter. Correspondingly, when some of other options are removed, Axiom IIA is used to discover the solution according to the revealed preference.

Behind the Consensus solution, our view is quite the opposite. There is no exogenous

preference to evaluate options. The options on the table are all we have. They shall be the sole basis to evaluate themselves. Put it alternatively, they should be peer-reviewed. Thus, what options are on the table matters even if they are not chosen as the solution. Based on these ideas, we classify all points of  $W$  using  $s$  and  $v$  into: Individually Irrational, Consensus, and Bargaining points; and those points, in turn, evaluate the desirability of  $v$ . Furthermore, Individually Irrational points are those that can be vetoed by players' action of choosing not to cooperate and we think they should be irrelevant, as shown by Axiom 4. Consensus points are clearly inferior to  $v$  and we think it should not hurt the desirability of  $v$  if there are more, as shown by Axiom 6. Bargaining points are the only type, between which and  $v$ , we do not have a clear tell who is better. This is where different positions can be taken. And the Consensus solution takes the one of an arbitrator who does not have a direct preference over options but prefers not to change the solution when there is less bargaining, as shown by Axiom 5.

In the Nash solution, the threat plays a fundamental role. It is conditional on the threat that the exogenous preference evaluates options bilaterally.<sup>7</sup> That is: the threat serves as the reference point, as can be seen in Nash's product, Axiom IIA, and Axiom 6Nb. This has some unintended consequences. First, the Nash solution does not satisfy a different version of symmetry. In Example 3b, let  $W'$  and  $W''$  be quadrilaterals  $s^1v^1vv^2$  and  $s^1a^1a^2v^2$  respectively. For  $(W', s^1)$ , both the Nash and Consensus solutions of  $(W', s^1)$  are  $v$ ; For  $(W'', s^1)$ , the Consensus solution is still  $v$  but the Nash solution changes to  $w^1$  despite that  $W'' \setminus W'$  are symmetric Bargaining points of  $v$ . Second, in the Nash solution, the

---

7. This is necessary because Axiom 3 deprives the meaning of the level of utilities.



threat always has strategic implications disregarding the cooperative aspect of the bargaining problem. In Figures 1.8a and 1.8c, whenever we lower one player's utility of the threat, the opponent player's utility of the Nash solution is higher.<sup>8</sup> Effectively, in the Nash solution, the threat acts like a bargaining chip to obtain higher utilities;

In the Consensus solution, the threat is simply to eliminate Individually Irrational points and then absent itself from the rest of bargaining. Put it differently, the threat first help define what the players have in common (Consensus points) and what they disagree with (Bargaining points) and then let them speak themselves, respecting the cooperative and non-cooperative aspects of the bargaining problem. Correspondingly, the relative position of the threat is not essential, as shown by Axiom 6.

In all, the Nash solution focuses on threat  $s$ , the anticipation of *no-cooperation*, and the Consensus solution focuses on  $W$ , what they can obtain via *cooperation*.

The different views are essentially a matter of modelling choice and logically there is no right or wrong. However, we still can assess them internally with the bargaining model that a solution rests on and externally with our common sense in real bargaining situations that a solution aims to fit. In the Nash's bargaining model (thus the one of this paper), players are assumed to be intelligent and rational enough. Therefore, they should be able to realize that it is nobody's interest to trigger the threat unless the utilities of the solution are lower than those of the threat. Thus, the threat itself shall have no strategic implication beyond eliminating Individually Irrational points. As for our common sense, in Example 1, the Consensus solution says that they should go biking 40% of the time and go hiking 60%

---

8. This reflects a general property of the Nash solution. More formally, for bargaining problem  $(W, s)$ , when  $s_2$  decreases, the Nash solution  $v_1$  increases as long as  $W$  is smooth at  $v$  and there exists  $w$  such that  $w_1 > v_1$ . This is directly implied by equation (2N).

of the time while the Nash solution says that they should go hiking 100%. And Axioms 6 and 6N provide formal ways for us to evaluate and experiment.

## 1.5 Other Discussions

### 1.5.1 (A)symmetry

Axiom 2 directly assumes symmetry. For models where players have no identity differences other than that they are called player 1 and 2 like the one in this paper, it is a natural assumption. However, in the real world, identity differences often exists. For example, bargaining may be between two gangs of different sizes, two kids of different ages, or a labor union and a firm. In those cases, assuming symmetry may not be appropriate.

How should we model the asymmetry caused by identity differences? It depends on the exact meaning of identity differences. If identity differences mean that players have different strategic advantages, e.g. a larger gang may have more weapons and a larger territory, such asymmetry should be investigated in richer bargaining models that incorporate the strategic components; if identity differences do not bear any strategic implication, e.g. a 4-year-old and 5-year-old bargaining over toys, while it is a moral difficulty to quantify the asymmetry, the Consensus solution does offer an interface. Consider a weighted version of problem  $(1^{\min})$

$$\min_{v \geq s, v \in E(W)} c_1 \mu(B_1(W, s, v)) + c_2 \mu(B_2(W, s, v)) \quad (1.6)$$

where  $c_1, c_2 \geq 0$  satisfying  $c_1 + c_2 = 2$ . Clearly,  $(c_1, c_2)$  can be used to quantify the asymmetry.

Intuitively, they are different weights on players' dissatisfaction. In terms of axiomatization,

for other  $c_1$  and  $c_2$ , it is not obvious what is the substitute of Axiom 2. But given a non-empty solution  $V(\cdot)$  satisfying all the axioms but Axiom 2, there exists a unique pair of  $(c_1, c_2)$  such that  $V(\cdot)$  is the solution of problem (1.6).

## 1.5.2 Interpersonal Comparison

While Axiom 3 rules out interpersonal comparison of utilities, sometime it is misunderstood as no interpersonal comparison at all.

First, players themselves can have interpersonal comparisons. In reality, different interpersonal comparisons, like envy, equity, and altruism, often comes together with bargaining. For example, we do see that a child and his parents bargain over his usage of tablets and consumption of ice-cream both are for the interest of the child. In models, these comparisons can be built into players' preferences over *physical allocations*. For example, the child's utility may be  $u_c = x_t + x_i$  where  $x_t, x_i \in [0, 1]$  stand for his usage of tablet and consumption of ice-cream respectively and his parents' utility may be  $u_p = 1 - x_t^2 - x_i^2 - x_c$  where  $x_c = \{1, 0\}$  stands if the child cries or not. If they do not reach an agreement, the child gets nothing and cries. We can easily write down the bargaining problem between the child and parents in the form of  $(W, s)$ .<sup>9</sup> Here, such comparisons *done by players* have already be encoded in  $(W, s)$  and shall not be repeated.

Second, solution  $V(\cdot)$  can also incorporate interpersonal comparisons. Problem  $(1^{\min})$  is one way to compare players' dissatisfaction; and problem (1.6) provide many other ways. In fact, we think that the nature of finding a solution is to conduct interpersonal comparisons.

---

9.  $s = (0, 0)$  and  $W$  is the area circumvented by lines  $u_c = 0$ ,  $u_p = -1$ , and curve  $u_p = 1 - \frac{u_c^2}{2}$ .

When conducting interpersonal comparisons, we need to be very careful about two things. First, interpersonal comparisons should be based on utilities instead of physical allocations. Otherwise, we may accidentally mix our own preferences into solution  $V(\cdot)$ . This is not a concern for Nash's bargaining model, which is written in terms of utilities. Second, comparison shall not vary with the measurements of utilities. This is simply because absolute values of utilities are meaningless.

### 1.5.3 Axiom 5

Axiom IIA says the solution does not change when there are less points; Axiom 5 says the same and additionally restricts the lessened to Bargaining points. This additional restriction makes Axiom 5 avoid some but not all the criticisms on Axiom IIA. For example, suppose  $W'$ , compared with  $W$ , contains less player 1's Bargaining points of  $V(W, s)$ . One may expect that player 2 should benefit from this change. But under Axiom 5, the solution remains unchanged. Clearly, Axiom 5 sacrifices the principle of compromise, just like Axiom IIA.

But if we look from a different perspective, there is some gain out of this sacrifice. The solution does not have to be frequently adjusted when the bargaining situation changes now and then. That is: the solution is stable. While the stability only looks appealing in the unstructured bargaining model like the one of this paper, it becomes a dominating factor when the risk is structured into the bargaining models as in Van Damme (1986) and Binmore et al. (1986). The Nash solution also satisfies Axiom 5 and in these structured models, emerges to be *the* solution. And in these models, the Consensus solution is the same with the Nash solution. In addition, when working together with Axiom 6, its controversial

effect is more limited. Consider Example 3a. It is the example in which the Consensus solution performs the worst in the following senses: 1. player 1 has no Bargaining points of  $v$  at all; 2. among all bargaining problems, its ratio of the areas of player 2's Bargaining points and  $v$ 's Consensus points is the highest (equal to  $\frac{1}{2}$ ).

Furthermore, if we were to discard Axiom 5 together with Axiom 6N, both of which are arguable, the new solution would be very different from the Nash solution and there might be a risk of adding further confusions. Thus in this paper, we only discard Axiom 6N and leave dealing with Axiom 5 in our companion work.

## 1.6 Appendix

### 1.6.1 Proof of Lemma 2

**Existence:** For any compact set  $W \subset \mathbb{R}^2$ , problem (1.3) has a solution.

*Proof.* Define  $g(v) \equiv \mu(\{w \in W | w \leq v\})$ . Since  $W$  is compact, it is sufficient to prove  $g(\cdot)$  is a continuous function.

Because  $W$  is compact, it must be bounded. Without loss of generality, assume it is bounded by a square  $D \subset \mathbb{R}^2$  and  $D$ 's edges are parallel with the two axes. Suppose the length of its each edge is  $d$ . For any two points  $v', v \in \mathbb{R}^2$ , we must have

$$|g(v') - g(v)| \leq |v'_1 - v_1|d + |v'_2 - v_2|d$$

Consider any given  $v \in \mathbb{R}^2$  and a sequence  $\{v^k\}_{k=1,2,\dots}$  in  $\mathbb{R}^2$  satisfying  $\|v - v^k\| \rightarrow 0$  as  $k \rightarrow \infty$ . From the above inequality, we must have  $|g(v^k) - g(v)| \rightarrow 0$  as  $k \rightarrow \infty$ . Thus  $g(\cdot)$

is continuous, as desired. ■

## 1.6.2 Formal Proof of Lemma 2

To prepare for the formal proof of Lemma 2, we transform  $\mu(\{w \in W | w \leq v\})$ , a function of a point, into a function of a scalar by parametrizing the efficient frontier  $E(W)$ .

Define the area of set  $\{w \in W | w_1 \geq v_1\}$  as  $B_1(v_1)$ ; similarly, define the area of set  $\{w \in W | w_2 \geq v_2\}$  as  $B_2(v_2)$ . Thus we have

$$\mu(\{w \in W | w \leq v\}) = \mu(W) - B_1(v_1) - B_2(v_2). \quad (1.7)$$

Define  $\bar{v}_1 = \max_{v \in E(W)} v_1$  and  $\bar{v}_2 = \max_{v \in E(W)} v_2$ .<sup>10</sup> Let  $I_1(w_1)$  be the length of interval  $\{m \in W | m_1 = w_1\}$  and similarly  $I_2(w_2)$  be the length of interval  $\{m \in W | m_2 = w_2\}$ . We have

$$B_1(v_1) = \int_{v_1}^{\bar{v}_1} I_1(w_1) dw_1 \quad (1.8)$$

---

10. They are well defined because  $E(W)$  is compact if  $W$  is convex and compact. Because  $W$  is compact, to prove  $E(W)$  is compact, we just need to show  $E(W)$  is closed in  $W$ . It is obviously true if  $W = E(W)$ ; if not, it is equivalent with showing  $W \setminus E(W)$ , the set of inefficient points, is open in  $W$ .

For any inefficient point  $w \in W$ , there are two cases:

- there exists some  $v \in W$  such that  $v_1 > w_1$  and  $v_2 > w_2$ . then there exists a neighborhood  $U$  of  $w$  in  $W$  such that for any  $w' \in U$   $v_1 > w'_1$  and  $v_2 > w'_2$ . That is  $U \subset W \setminus E(W)$ .
- there does not exist  $v \in W$  such that  $v_1 > w_1$  and  $v_2 > w_2$ . But there must exist  $v \succeq w$  because  $w$  is an inefficient point. Without loss of generality, we assume  $v_1 = w_1$  and  $v_2 > w_2$ . Let  $v' \in \operatorname{argmax}_{w' \in W} w'_1$ . It must be that  $v_1 = v'_1$ ; otherwise, let  $v'' = tv' + (1-t)v \in W$ , for small enough  $t$ , we have  $v''_1 > w_1$  and  $v''_2 > w_2$ . A contradiction with assumption of this case. Thus there exists a neighborhood  $U$  of  $w$  in  $W$  such that for any  $w' \in U$   $v_1 \geq w'_1$  and  $v_2 > w'_2$ . That is  $U \subset W \setminus E(W)$

In all,  $W \setminus E(W)$  is open in  $W$ , as desired. Also,  $W$  being convex is necessary here.  $W = \{w | w_1 = 0, 1 \leq w_2 \leq 2 \cup w | w_1 + w_2 = 1, 0 \leq w_1 \leq 1\}$  is an example that  $W$  is compact but  $E(W)$  not.

<sup>11</sup> and

$$B_2(v_2) = \int_{v_2}^{\bar{v}_2} I_2(w_2)dw_2. \quad (1.9)$$

Since  $W$  is a convex set,  $E(W)$  can be represented by a strictly decreasing, continuous and concave function  $f(\cdot)$  such that for any  $v \in E(W)$ ,  $v_2 = f(v_1)$ .  $f(\cdot)$ 's domain is  $[\underline{v}_1, \bar{v}_1]$  where  $\underline{v}_1 = \min_{v \in E(W)} v_1$ . Substitute  $v_2 = f(v_1)$  into equation (1.9), and further substitute equations (1.9) and (1.8) into (1.7), then we get a function of  $v_1$ . Denote it as  $g(v_1)$ .

$$g(v_1) = \mu(\{w \in W | w \leq v\}) = \mu(W) - \int_{v_1}^{\bar{v}_1} I_1(w_1)dw_1 - \int_{f(v_1)}^{\bar{v}_2} I_2(w_2)dw_2. \quad (1.10)$$

Thus problem (1.3) is equivalent with the below problem

$$\max_{v_1 \in [\underline{v}_1, \bar{v}_1]} g(v_1). \quad (1.11)$$

Problem (1.11)'s first order condition is

$$\begin{cases} g'_l(v_1) \geq 0 & v_1 \in (\underline{v}_1, \bar{v}_1] \\ g'_r(v_1) \leq 0 & v_1 \in [\underline{v}_1, \bar{v}_1). \end{cases} \quad (1.12)$$

where  $g'_l(\cdot)$  and  $g'_r(\cdot)$  are  $g(\cdot)$ 's left and right derivatives. <sup>12</sup>

In below, we further show in Lemma 4 the equivalence of problem (1.11) and inequality (1.12) and in Lemma 5 the equivalence of inequality (1.12) and equality (1.2). They together

---

11. This integration is the definition of area in terms of Riemann integral. It is well defined because  $I_1(\cdot)$  is continuous in closed interval  $[\underline{v}_1, \bar{v}_1]$  therefore integrable.

12. The well-definedness of  $g'_l(\cdot)$  and  $g'_r(\cdot)$  is explained shortly.

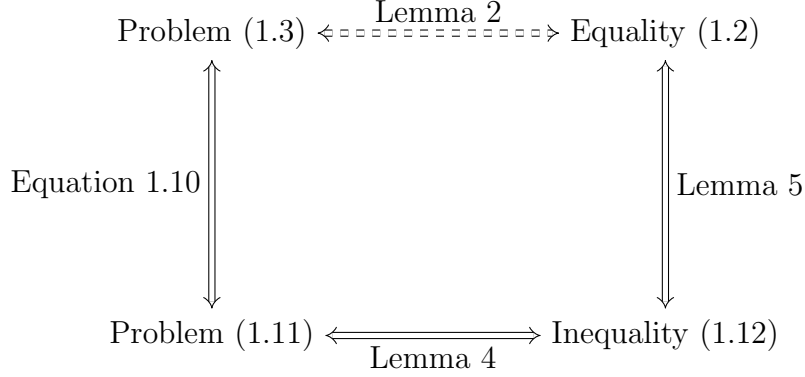

Figure 1.12: Roadmap of the Proof of Lemma 2

constitute the proof of Lemma 2 as illustrated in Figure 1.12.

Before presenting Lemmas 4 and 5, we need to explicitly express  $g'_l(v_1)$  and  $g'_r(v_1)$ . Since  $f(\cdot)$  is continuous and concave, its left and right derivatives,  $f'_l(\cdot)$  and  $f'_r(\cdot)$ , are well defined on  $(v_1, \bar{v}_1]$  and  $[v_1, \bar{v}_1)$  respectively. Let cone  $N(v)$  be the set of outward normal vectors of  $W$  at  $v$ . Notice that  $N(v)$ 's two edges are orthogonal with their corresponding supporting lines whose slopes are respectively equal to  $f'_l(v)$  and  $f'_r(v)$ . Therefore we denote the two edges as  $n^l$  and  $n^r$ , as shown in Figure 1.13, such that

$$\begin{cases} f'_l(v_1) = -\frac{n_1^l}{n_2^l} & v_1 \in (v_1, \bar{v}_1] \\ f'_r(v_1) = -\frac{n_1^r}{n_2^r} & v_1 \in [v_1, \bar{v}_1). \end{cases} \quad (1.13)$$

Notice that  $I_1(v_1) = |vv^1|$  and  $I_2(v_2) = |vv^2|$ . In below, for convenience, we write them in short as  $I_1$  and  $I_2$ . Applying the chain rule in equation (1.10) and substituting it with



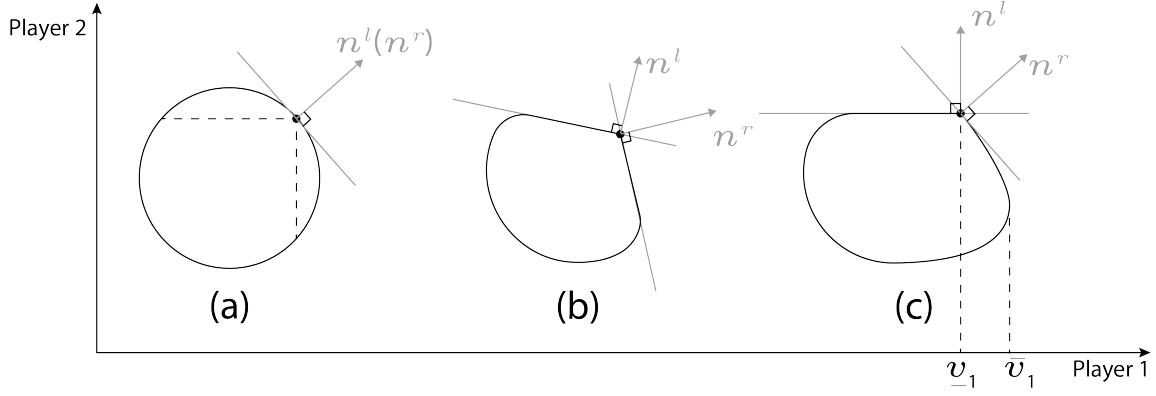

Figure 1.13: Normal Vectors

equation (1.13), we have  $g(\cdot)$ 's left and right derivatives: <sup>13</sup>

$$\left\{ \begin{array}{l} g'_l(v_1) = I_1 + f'_l(v_1)I_2 \\ \qquad \qquad = I_1 - \frac{n_1^l}{n_2^l}I_2 \\ g'_r(v_1) = I_1 + f'_r(v_1)I_2 \\ \qquad \qquad = I_1 - \frac{n_1^r}{n_2^r}I_2 \end{array} \right. \begin{array}{l} v_1 \in (v_{\underline{1}}, \bar{v}_1] \\ v_1 \in [v_{\underline{1}}, \bar{v}_1) \end{array} \quad (1.14)$$

When  $v_1 \in (v_{\underline{1}}, \bar{v}_1]$ , obviously we have  $I_2 \neq 0$ , we can write  $g'_l(v_1)$  further as

$$g'_l(v_1) = I_2 \left( \frac{I_1}{I_2} - \frac{n_1^l}{n_2^l} \right). \quad (1.15)$$

Now we can present Lemmas 4 and 5.

**Lemma 4.** *Suppose  $W$  is convex, compact, and full dimensional.  $v_1$  is a solution of problem (1.11) if and only if inequality (1.12) holds.*

<sup>13</sup>. In  $g'_l(v_1)$ ,  $-\frac{n_1^l}{n_2^l}$  can be  $-\infty$  if  $v_{\underline{1}} < v_1 = \bar{v}_1$ . Since  $I_2(v) > 0$ ,  $g'_l(v_1)$  is still well defined and equal to  $-\infty$ .

*Proof.* The “Only If” part holds simply because inequality (1.12) is problem (1.11)’s first order condition.

Now we show its “If” part. Observe equation (1.15). Term  $-\frac{n_1^l}{n_2}$  weakly decreases with  $v_1$  because it is concave function  $f(\cdot)$ ’s left derivative(see equation (1.13)). **If  $\frac{I_1}{I_2}$  also weakly decreases with  $v_1$** , then  $g_l'(v_1)$ ’s sign can only change one direction: from strictly positive to zero, from zero to strictly negative, and from strictly positive to strictly negative. Therefore as  $v_1 \in [\underline{v}_1, \bar{v}_1]$  increases, not all of the below three phases necessarily happen, but they have to happen in the below order:

1.  $g(v_1)$  strictly increases;
2.  $g(v_1)$  stays constant;
3.  $g(v_1)$  strictly decreases.

Thus for problem (1.11), its first order condition, inequality (1.12), is also sufficient.

Thus we just need to prove  $\frac{I_1}{I_2}$  indeed weakly decreases with  $v_1$ . Consider any two distinct efficient points  $v$  and  $v'$ . Without loss of generality, suppose  $v_1 < v_1'$ .  $v^1$  and  $v'^1$  are defined similarly with  $v^1$  and  $v'^1$ . They all are extreme points of  $W$ .

Let  $a^1$  be the intersection between lines  $v^1v^2$  and  $vv^1$ . It has to be that  $|vv^1| \geq |va^1|$ . Or else,  $v^1$  would be an interior point of quadrilateral  $v^2vv^1v^1$ . A contradiction with  $v^1$  being an extreme point of  $W$ . Thus

$$\frac{|vv^1|}{|vv^2|} \geq \frac{|va^1|}{|vv^2|}. \quad (1.16)$$

Similarly, let  $a^2$  be the intersection between lines  $v'^1v^2$  and  $v'v'^2$ . It has to be that  $|v'v'^2| \geq$

$|v'a^2|$ . Or else,  $v'^2$  would be an interior point of quadrilateral  $v^2vv'v^1$ . And we have

$$\frac{|v'v^1|}{|v'a^2|} \geq \frac{|v'v^1|}{|v'v'^2|}. \quad (1.17)$$

Notice that the right side of equation (1.16) and the left side of equation (1.17) are both equal to the slope of line  $v^1v^2$ . Thus we have

$$\frac{I_1}{I_2} = \frac{|vv^1|}{|vv^2|} \geq \frac{|v'v^1|}{|v'v'^2|} = \frac{I'_1}{I'_2}.$$

This means  $\frac{I_1}{I_2}$  indeed weakly decreases with  $v_1$ , as desired. ■

**Lemma 5.** *Suppose  $W$  is convex, compact, full dimensional, and  $E(W)$  is not a singleton.*

*For a given  $v \in E(W)$ , there exists a normal vector  $n \in N(v)$  such that equality (1.2) holds if and only if inequality (1.12) holds. Moreover, when inequality (1.12) holds,  $I_1, I_2 > 0$  ( $I_1 = |vv^1|$  and  $I_2 = |vv^2|$ ).*

*Proof.* The proof here involves nothing but carefully dealing with well-definedness and corner cases. Consider the below equivalences

$$\left\{ \begin{array}{l} I_1 - \frac{n_1^l}{n_2^l} I_2 \geq 0 \quad v_1 \in (\bar{v}_1, \bar{v}_1] \\ I_1 - \frac{n_1^r}{n_2^r} I_2 \leq 0 \quad v_1 \in [\bar{v}_1, \bar{v}_1) \end{array} \right\} \xrightarrow[\text{Condition (c)}]{\text{Conditions (a) and (b)}} \frac{I_1}{I_2} \in \left[ \frac{n_1^l}{n_2^l}, \frac{n_1^r}{n_2^r} \right] \xrightarrow[\text{Condition (d)}]{\text{Condition (d)}} \exists n, \frac{I_1}{I_2} = \frac{n_1}{n_2}. \quad (1.18)$$

Its leftside is inequality (1.12)(obtained by substituting expression (1.14) into (1.12)). Its rightside is equality (1.2). The conditions attached to each arrow are what needed to establish the corresponding direction of equivalence. All of them are as follows:

- (a) if  $v_1 = v_1$  and  $v_1 = \bar{v}_1$ , inequalities (1.12) still hold;
- (b)  $I_2$  is strictly positive;
- (c) whenever  $I_2 = 0$ ,  $I_1 \neq 0$  and neither  $\frac{n_1^l}{n_2^l}$  nor  $\frac{n_1^r}{n_2^r}$  is  $\infty$ ;
- (d)  $\frac{n_1^l}{n_2^l}$  and  $\frac{n_1^r}{n_2^r}$  are non-negative.

We verify conditions (a)-(d) under the following three cases.

First, when  $v_1 < v_1 < \bar{v}_1$ , as shown in Figure 1.13a and 1.13b, the condition of condition (a) does not apply. Since both player 1 and 2's Bargaining Points of  $v$  are nonempty, thus  $I_1, I_2 > 0$ . Furthermore, conditions (b), (c) and (d) are satisfied.

Second, when  $v_1 = v_1 < \bar{v}_1$ , player 1's set of Bargaining Points is non-empty. Then obviously  $I_1 > 0$ ,  $n_2^r > 0$ , and  $n_2^l > 0$  (condition (c) is satisfied), as shown in Figure 1.13c. Thus inequality  $I_1 - \frac{n_1^r}{n_2^r} I_2 \leq 0$ , leftside of equivalence (1.18), implies  $n_1^r > 0$  and  $I_2 > 0$  (condition (b)). Also  $I_2 > 0$  implies  $n_1^l = 0$ , thus  $I_1 - \frac{n_1^l}{n_2^l} I_2 = I_1 \geq 0$  (condition (a)). Now condition (d) clearly holds.

Last, when  $v_1 < v_1 = \bar{v}_1$ , it is essentially the same with the second case if in above we represent the efficient frontier as a function of  $v_2$ .

Notice that in above three cases, we have also concluded  $I_1, I_2 > 0$ . ■

### 1.6.3 Proof of Lemma 3

We just need to show if the solutions of problem (1.11)(therefore problem (1.3)) are not unique,  $W$  has to be an Odd Bargaining set.

Clearly  $W$ 's efficient frontier is not a singleton. From Lemma 2, we know for any solution

$v$ ,  $\frac{I_1}{I_2} = \frac{n_1}{n_2}$ . The monotonicity of  $\frac{n_1}{n_2}$  and  $\frac{I_1}{I_2}$  proved in Lemma 4 further imply:  $\frac{n_1}{n_2}$  has to be the same for any solution, so does  $\frac{I_1}{I_2}$ .

$\frac{n_1}{n_2}$  being the same for any solution implies that all solutions share and are on the same supporting line  $T$ . Suppose both  $v$  and  $v'$  are two distinct solutions. Due to Lemma 2, both lines  $v^1v^2$  and  $v'^1v'^2$  are parallel with  $T$ . If  $v'^1v'^2$  is between  $v^1v^2$  and  $T(vv')$ , either  $v'^1$  or  $v'^2$  is an interior point of the trapezoid with four vertices  $v$ ,  $v'$ ,  $v^1$ , and  $v^2$ . A contradiction with  $v^1$  and  $v^2$  being extreme points of  $W$ . Similarly, it cannot be that  $v^1v^2$  is between  $v'^1v'^2$  and  $T(vv')$ . Thus lines  $v^1v^2$  and  $v'^1v'^2$  have to coincide. Call them as line  $L$ .

Also according to the proof of Lemma 4, the set of all the solutions has to be connected. And since  $g(\cdot)$  is continuous, it is also closed. Therefore, we can suppose the set of all the solutions is an interval  $I$ . That is  $W$  has to be an Odd Bargaining set.

#### 1.6.4 Proof of Theorem 2b

The ‘‘If part’’ of Theorem 2b can be simply verified. In below, we prove its ‘‘Only If part.’’

*Only If part:* If  $V(\cdot)$  of  $\mathbb{B}$  satisfies Axioms 1 - 5, and 6N, for any  $(W, s) \in \mathbb{B}$ ,  $V(W, s)$  is the solution of problem (1N). Suppose  $v$  solves problem (1N). We prove this part by showing  $V(W, s) = v$ .

If  $E(R(W, s))$  is a singleton, due to Axiom 1, we have  $V(R(W, s), s) = v$ . Also, due to Axiom 4, we have  $V(W, s) = V(R(W, s), s)$ . Thus  $V(W, s) = v$ .

If  $E(R(W, s))$  is not a singleton, we prove  $V(W, s) = v$  in below eight steps and they are illustrated in Figure 1.14.

- (a) Since  $v$  solves problem (1N), according to part (b) of Theorem 1N, we have a normal

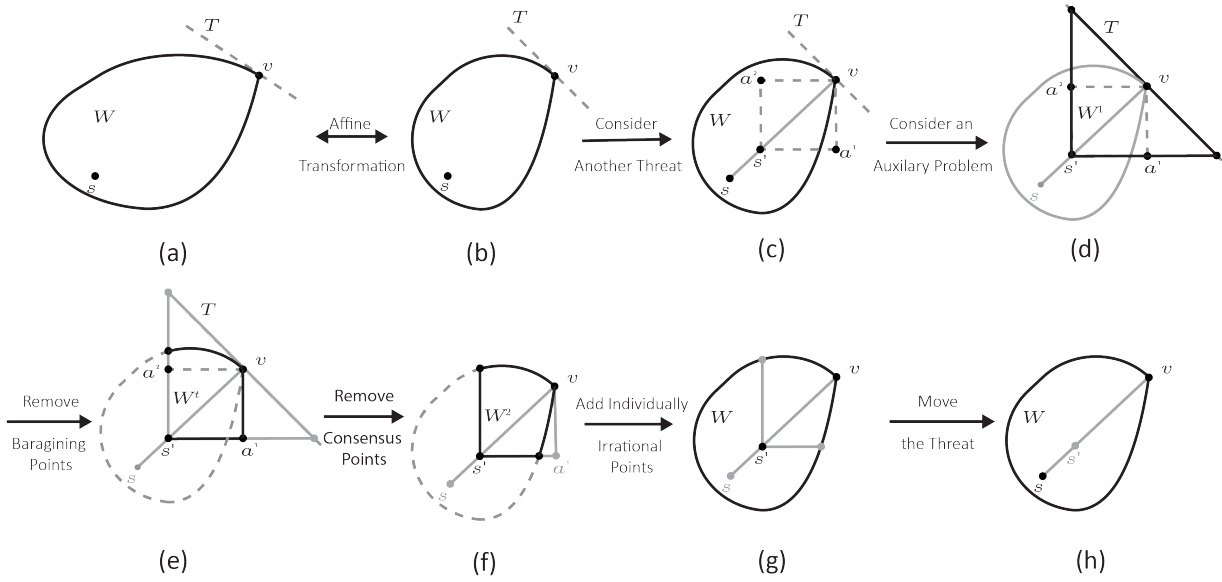

Figure 1.14: Proof of Theorem 2b

vector  $n$  at  $v$  such that equation (2N) holds. Suppose  $n$ 's corresponding supporting line is  $T$ .

(b) Due to Axiom 3, it is equivalent to prove  $V(W, s) = v$  after order-preserving affine transformations on utilities. Implement affine transformations such that both  $s$  and  $v$  are symmetric points. Since under the affine transformation equation (2N) still holds. Thus  $T$ 's slope must be  $-1$ .

(c) Let  $s'$  be a point on interval  $sv$  that is distinct from  $s$  and  $v$ . Clearly,  $s'$  is symmetric. Let  $a^1$  be the intersection of the vertical line passing  $v$  and the horizontal line passing  $s'$ ; similarly, let  $a^2$  be the intersection of the horizontal line passing  $v$  and the vertical line passing  $s'$ .

We choose  $s'$  close enough to  $v$  such that both  $a^1 \in W$  and  $a^2 \in W$  whenever possible. Notice that when  $a^1 \in W$  is not possible, it must be the case that player 1 has no

Bargaining points of  $v$  in  $(W, s)$ ; similarly, for  $a^2$ . Since  $E(R(W, s))$  is not a singleton, for at least one player, there are Bargaining points. That is at least we have  $a^1 \in W$  or  $a^2 \in W$ .

If  $a^1 \in W$  and  $a^2 \in W$ ,  $R(W, s')$  contains square  $sa^1va^2$ ; if  $a^1 \notin W$  and  $a^2 \in W$ ,  $R(W, s')$  is left to line  $va^1$  and above line  $sa^1$ , that is they are convex set  $R(W, s')$ 's hyperplane, as shown in Figure 1.14; similarly for  $a^1 \in W$  and  $a^2 \notin W$ . In any case, we have  $W^t$ , the union of  $R(W, s')$  and square  $sa^1va^2$ , is convex.

- (d) Let  $W^1$  be the triangle area circumvented by lines  $T$ ,  $s'a^1$ , and  $s'a^2$ .  $W^1$  must be symmetric. According to Axioms 1 and 2,  $V(W^1, s') = v$ .
- (e) Since  $W^t$  is convex (see step (b)) and also notice that  $W^1 \setminus W^t$  are players' Bargaining points of  $v$ , according to Axiom 5,  $V(W^t, s') = V(W^1, s') = v$ .
- (f) Now denote  $R(W, s')$  as  $W^2$ . Notice that  $W^t \setminus W^2$  are Consensus points of  $v$ . Thus according to Axiom 6Na,  $V(W^2, s') = V(W^t, s') = v$ .
- (g) Since  $W^2 \equiv R(W, s')$ ,  $R(W, s') = R(W^2, s')$ . According to Axiom 4,  $V(W, s') = V(W^2, s') = v$ .
- (h) Notice that  $s$  is on line  $s'v$ . According to Axiom 6Nb,  $V(W, s) = V(W, s') = v$ , as desired.

## Chapter 2

# On the Equilibrium Properties of Network Models with Heterogeneous Agents

with Treb Allen and Costas Arkolakis



## 2.1 Introduction

The twenty first century has witnessed the rise of big data and big models in the social sciences. Exponential growth in computational capacity combined with access to new micro-level datasets have allowed the empirical implementation of models where large numbers of heterogeneous agents interact simultaneously with each other in myriad ways. While the rise of big data and big models has introduced empirical content to traditionally theoretical fields, important questions about the positive properties of these big models remain unresolved. Two concerns – critical for applied work – are particularly pressing: How can we compute the solution of an equilibrium system with hundreds or thousands of heterogeneous agents efficiently? And even if we do calculate a solution, how do we know that the equilibrium we find is the only possible one?

In this note, we answer these questions for a large class of models where many heterogeneous agents simultaneously interact in many ways. In particular, we consider systems where  $N$  heterogeneous agents engage in  $H$  types of interactions whose equilibrium can be reduced to a set of  $N \times H$  equations of the following form:

$$x_{ih} = \sum_{j=1}^N f_{ijh}(x_{j1}, \dots, x_{jH}), \quad (2.1)$$

where  $\{x_{ih}\} \in \mathbb{R}_{++}^{N \times H}$  reflect the (strictly positive) equilibrium outcomes for each agent of each interaction and  $f_{ijh} : \mathbb{R}_{++}^H \rightarrow \mathbb{R}_{++}$  are the known (differentiable) functions that govern the interactions between different agents. In particular,  $f_{ijh}$  is the function that governs the impact that an interaction with agent  $j$  has on agent  $i$ 's equilibrium outcome of type  $h$ .<sup>1</sup>

---

1. These interactions could be market interactions or non-market interactions (as discussed by Glaeser

As we illustrate, this formulation is sufficiently general to capture models of many different economic networks – from firm linkages to social networks to the spatial structure of cities.

The contribution of the paper is to provide conditions under which an equilibrium satisfying equation (2.1) is unique and can be calculated using an iterative algorithm. The key insight, loosely speaking, is to simplify the analysis by abstracting from agent heterogeneity and focusing on the strength of economic interactions. Formally, rather than focusing on the  $N^2 \times H$  functions  $\{f_{ijh}\}$ , we instead focus on the  $H \times H$  matrix of the uniform bounds of the elasticities  $\epsilon_{hh'} \equiv \sup_{i,j,\{x_{jh}\}} \left( \left| \frac{\partial \ln f_{ijh}(\{x_{jh}\}_h)}{\partial \ln x_{jh'}} \right| \right)$ . The conditions provided depend only on a single statistic of this matrix: its spectral radius being less than one (or, with additional restrictions on  $\{f_{ijh}\}$ , equal to one).<sup>2</sup> Moreover, the conditions provided are shown to be “globally necessary”, i.e. they are the best possible conditions that are agnostic about the heterogeneity across agents: formally, we show that if the conditions are not satisfied, there exist  $\{f_{ijh}\}$  where multiplicity is assured.

Our main result relies on a multi-dimensional extension of the contraction mapping theorem, which – to our knowledge – is new and of independent interest in its own right. The insight of this extension is that it is possible to partition the space of endogenous variables into subsets, each of which operates in a different metric subspace. This partition is particularly helpful in economic models where heterogeneous agents interact in many ways  

---

 et al. (2003); Glaeser and Scheinkman (2002)).

2. The spectral radius plays a number of important roles in economics, e.g. in the characterization of macro-economic stability (see e.g. Hawkins and Simon (1949)) and the solution of linearized DSGE models (Fernández-Villaverde et al. (2016)). More recently, Elliott and Golub (2019) shows that the spectral radius characterizes the efficiency of public goods provision in networks with non uniform externalities. To our knowledge, this note is the first to show that the spectral radius of a matrix of elasticities of economic interactions characterizes the uniqueness of (and the speed of convergence of an iterative algorithm to) the equilibrium of a network model with many heterogenous agents.

(i.e.  $H$  is large), as it allows us to separate the study of each type of interaction.

To illustrate the versatility of our approach, consider two alternative strategies often employed to analyze the equilibrium properties of a system. The first alternative strategy is to recursively apply a process of substitution to re-define the equilibrium system as a function of fewer economic interactions. For example, in a simple exchange economy with multiple agents and multiple goods, there are two interactions – buying and selling, which in equilibrium can be summarized by the value of each agent’s endowment (wages) and consumption bundle (price index). Alvarez and Lucas (2007) characterize the equilibrium of such a system by first substituting wages into the price index and then analyzing the structure of the model only in terms of wages.<sup>3</sup> While feasible for small  $H$ , the complexity of this strategy increases exponentially with the number of interactions in the model, creating a curse of dimensionality for large  $H$ .

The second alternative strategy is to “stack” all economic outcomes into a single  $NH \times 1$  vector and apply standard contraction mapping arguments. The disadvantage of such an approach is that it treats different types of economic outcomes identically – despite the fact that they may play very different roles in the equilibrium system. The results in a loss of information and introduces the possibility that the sufficient conditions may fail despite the system being unique.<sup>4</sup> In contrast, our approach both avoids the curse of dimensionality of

---

3. Indeed, Allen et al. (2014) show that the sufficient conditions presented in Alvarez and Lucas (2007) – which rely on showing the gross substitutes property of the system, c.f. Mas-Colell et al. (1995) – can be relaxed when treating wages and the price index separately. The results here extend those of Allen et al. (2014) both by allowing for general (non-constant elasticity) functional forms and by allowing for more than two types of economic interactions.

4. A simple example is the following system where  $N = 1$  and  $H = 2$ :  $x_{11} = x_{11}^{\frac{1}{2}}x_{12}^2 + 1$ ,  $x_{12} = x_{12}^{\frac{1}{2}} + 1$ . It is straightforward to show that by treating  $x_{11}$  and  $x_{12}$  as a single vector variable, the standard contraction conditions that the matrix norm (induced by the vector norm) of the system’s Jacobian matrix is strictly less than one (see e.g. Olver (2008) Chapter 9) are not satisfied, whereas the multi-dimensional contraction mapping conditions we provide are satisfied. See Online Appendix 2.5.5 for details.

the first strategy and the loss of information inherent to the second, permitting an analysis of economic systems with large numbers of interactions.

We provide additional results for a special case of equation (2.1) where the elasticities  $\frac{\partial \ln f_{ijh}(\{x_{jh}\}_h)}{\partial \ln x_{jh'}}$  are constant and identical across agents. This case has emerged as the de-facto benchmark in the “quantitative” spatial literature, spanning the fields of international trade, economic geography, and urban economics (see e.g. the excellent review articles by Costinot and Rodriguez-Clare (2013) and Redding and Rossi-Hansberg (2017)). We also offer results that facilitate the analytical characterization of the spectral radius condition and, as a result, the parametric region where uniqueness and computation is feasible.

We finally apply our theorem to offer new results and extensions of seminal models from disparate fields in economics, illustrating its broad applicability. In particular, in the field of spatial economics, we provide uniqueness conditions for quantitative urban models in the spirit of Ahlfeldt et al. (2015) in the presence of spatial productivity and amenity spillovers. In the field of macroeconomics, we provide uniqueness results for the sectoral production network in the spirit of Acemoglu et al. (2012) but generalized to allow for non unit elasticities of substitution as in Carvalho et al. (2019). In the field of social networks, we provide uniqueness conditions for a model of discrete choice with social interactions in the spirit of Brock and Durlauf (2001) but generalized to allow for many choices and arbitrary weights on others’ actions.

A voluminous literature in economic theory has used fixed point theorems to analyze existence and uniqueness of solutions of economic models. The literature has offered three main approaches in order to characterize the positive properties of economic models: (1) use of the contraction mapping theorem; (2) conditions on the Jacobian matrix such as

it satisfying gross substitution or it being an M-matrix (see e.g. Mas-Colell et al. (1995) chapter seventeen, Arrow et al. (1971) chapter nine, and Gale and Nikaido (1965)); or (3) the Index Theorem.<sup>5</sup> This paper follows the first approach. While the latter two approaches are powerful, they are often impractical to apply to situations where many agents interact in many ways. For example, the Jacobian of equation (2.1) is of size  $HN^2 \times HN^2$ , making it difficult to characterize; in contrast, the conditions below depend on a single statistic of an  $H \times H$  matrix.<sup>6</sup> Similarly, the the Index Theorem has typically proven impractical to apply to production economies.<sup>7</sup> Our contribution to this literature is to show that for a general class of models with heterogeneous agents and multiple interactions a multi-dimensional extension of the contraction mapping theorem can be a powerful tool in characterizing their properties. The resulting theorem provides easy-to-verify conditions for uniqueness of an equilibrium and an algorithm for its computation.

The structure of the remainder of the note is as follows: Section 2 presents the multi-

---

5. Notice that substitutability conditions are effectively conditions on the cross-derivatives of the Jacobian. Berry et al. (2013) show that a relaxed form of substitutability, weak gross-substitutes, together with strict connectedness are sufficient for invertibility (in our context, uniqueness). In a setup that maintains the assumptions of a typical Walrasian economy, Iritani (1981) shows that Weak Indecomposability is necessary and sufficient for uniqueness. He also shows that a stronger form of Weak Indecomposability implies Weak Gross substitutability so these analysis are intimately related. Kennan (2001) shows that concave monotonically increasing functions have a unique positive fixed point; here, we make no restrictions that the functions be monotonic, increasing, or concave (although the condition that the spectral radius of the matrix of bounds of the elasticities be no greater than one does simplify to a requirement of quasi-concavity in the special case where  $N = H = 1$  and the function being considered is monotonically increasing).

6. Even when the Jacobian can be characterized, the conditions required to establish uniqueness may be too stringent. For example, consider the system  $x_i = \sum_{j=1}^N K_{ij}x_j^\alpha$  for  $K_{ij} > 0$  and  $\alpha \in (0, 1)$ . The  $i^{th}$  diagonal term of its Jacobian is  $1 - \alpha K_{ii}x_i^{\alpha-1}$  which can be negative or positive, violating e.g. the classical condition of Gale and Nikaido (1965) that all principal submatrices of the Jacobian have positive determinants. In contrast, the spectral radius of the elasticity is  $\alpha < 1$ , so uniqueness is established immediately by the Theorem presented here.

7. See an extensive discussion on the applications of the index theorem to exchange and production economies in Kehoe (1985); Kehoe et al. (1985). While mathematically powerful, the index theorem conditions typically lose their sufficiency when attempted to translate them in economically interpretable conditions.

dimensional contraction mapping extension (Lemma 1), offers the main result (Theorem 1), and makes five remarks. Section 3 presents three applications of the result to the fields of spatial networks, sectoral production networks, and social networks, respectively. For brevity, the proof of Lemma 1 and Theorem 1 are presented in the Appendix, and details of the remarks and applications are presented in the Online Appendix.

## 2.2 Main Results

We start our presentation by offering a multi-dimensional extension of the standard contraction mapping theorem. While of interest in itself, it also facilitates the proof of Theorem 1 below.

**Lemma 1.** *Let  $\{(X_h, d_h)\}_{h=1,2,\dots,H}$  be  $H$  metric spaces where  $X_h$  is a set and  $d_h$  is its corresponding metric. Define  $X \equiv X_1 \times X_2 \times \dots \times X_H$ , and  $d : X \times X \rightarrow \mathbb{R}_+^H$  such*

*that for  $x = (x_1, \dots, x_H), x' = (x'_1, \dots, x'_H) \in X$ ,  $d(x, x') = \begin{pmatrix} d_1(x_1, x'_1) \\ \dots \\ d_H(x_H, x'_H) \end{pmatrix}$ . Given operator*

*$T : X \rightarrow X$ , suppose for any  $x, x' \in X$*

$$d(T(x), T(x')) \leq \mathbf{A}d(x, x'), \quad (2.2)$$

*where  $\mathbf{A}$  is a non-negative matrix and the inequality is entry-wise. Denote  $\rho(\mathbf{A})$  as the spectral radius (largest eigenvalue in absolute value) of  $\mathbf{A}$ .*

*If  $\rho(\mathbf{A}) < 1$  and for all  $h = 1, 2, \dots, H$ ,  $(X_h, d_h)$  is complete, there exists a unique fixed point of  $T$ , and for any  $x \in X$ , the sequence of  $x, T(x), T(T(x)), \dots$  converges to the fixed point of  $T$ .*

*Proof.* See Appendix 2.5.1. ■

Lemma 1 extends the standard contraction mapping result to multiple dimensions by replacing the contraction constant with the matrix  $\mathbf{A}$ . It then states that a simple sufficient statistic of that matrix – its spectral radius  $\rho(\mathbf{A})$  – replaces the role of the contraction constant in determining the contraction of the system. This sufficient statistic succinctly summarizes the role of the asymmetry of the impact of the different variables in determining the positive properties of the system: as long as the spectral radius is less than one there exists a unique fixed point, and it can be computed by applying the mapping  $T(x)$  iteratively, which converges to the fixed point at a rate  $\rho(\mathbf{A})$ . Intuitively, a spectral radius of less than one holds if and only if the sequence  $\lim_{k \rightarrow \infty} \mathbf{A}^k$  converges to zero so that repeated applications of the operator eventually bound the set of points of the sequence arbitrarily close to the fixed point. Note that Lemma 1 reduces to the standard contraction mapping theorem if  $H = 1$  (see e.g. Theorem 3.2 of Lucas and Stokey (1989)).

### 2.2.1 Main Theorem

As mentioned in the introduction, the main result of the paper concerns systems whose equilibrium can be written as in equation (2.1). Before presenting our main result, some additional notation is in order. Let  $\mathcal{N} \equiv \{1, \dots, N\}$  and  $\mathcal{H} \equiv \{1, \dots, H\}$  correspond to the set of economic agents and the set of economic interactions, respectively. Let  $x$  be an  $N$ -by- $H$  matrix of endogenous economic outcomes, where for  $i \in \mathcal{N}$  and  $h \in \mathcal{H}$ , we (slightly abuse notation) and let  $x_i$  denote  $x$ 's  $i$ th row and  $x_h$  to denote  $x$ 's  $h$ th column. We restrict our attention to strictly positive  $\{x_{ih}\}_{i \in \mathcal{N}, h \in \mathcal{H}} \in \mathbb{R}_{++}^{N \times H}$  and strictly positive and differentiable

$\{f_{ijh}\}$ . Finally, define the elasticity  $\epsilon_{ijh,jh'}(x_j) \equiv \frac{\partial \ln f_{ijh}(x_j)}{\partial \ln x_{jh'}}$ , i.e.  $\epsilon_{ijh,jh'}(x_j)$  is the impact of agent  $j$ 's outcome of type  $h'$  on agent  $i$ 's outcome of type  $h$ .

**Theorem 1.** *Suppose there exists an  $H$ -by- $H$  matrix  $\mathbf{A}$  such that for all  $i, j \in \mathcal{N}$ ,  $h, h' \in \mathcal{H}$ , and  $x_j \in \mathbb{R}_{++}^H$   $|\epsilon_{ijh,jh'}(x_j)| \leq (\mathbf{A})_{hh'}$ . Then:*

(i). *If  $\rho(\mathbf{A}) < 1$ , then there exists a unique solution to equation (2.1) and the unique solution can be computed by iteratively applying equation (2.1) with a rate of convergence  $\rho(\mathbf{A})$ ;*

(ii). *If  $\rho(\mathbf{A}) = 1$  and:*

a. *If  $|\epsilon_{ijh,jh'}(x_j)| < (\mathbf{A})_{hh'}$  for all  $i, j \in \mathcal{N}$  and  $h, h' \in \mathcal{H}$  when  $(\mathbf{A})_{hh'} \neq 0$ , then equation (2.1) has at most one solution  $x$ ;*

b. *If  $\epsilon_{ijh,jh'}(x_j) = \alpha_{hh'} \in \mathbb{R}$  where  $|\alpha_{hh'}| = (\mathbf{A})_{hh'}$  for all  $i, j \in \mathcal{N}$  and  $h, h' \in \mathcal{H}$  i.e.  $f_{ijh}(x_j) = K_{ijh} \prod_{h' \in \mathcal{H}} x_{jh'}^{\alpha_{hh'}}$  for some  $K_{ijh} > 0$ —then equation (2.1)'s solution is column-wise up-to-scale unique, i.e. for any  $h \in \mathcal{H}$  and solutions  $x$  and  $x'$  it must be  $x'_h = c_h x_h$  for some scalar  $c_h > 0$ ;*

(iii). *If  $\rho(\mathbf{A}) > 1$ ,  $N \geq 2H + 1$ , and  $f_{ijh}(x_j) = K_{ijh} \prod_{h' \in \mathcal{H}} x_{jh'}^{\alpha_{hh'}}$ , then there exists some  $\{K_{ijh} > 0\}_{i,j \in \mathcal{N}, h \in \mathcal{H}}$  such that equation (2.1) has multiple solutions that are column-wise up-to-scale different.*

*Proof.* See Appendix 2.5.2. ■

It is important to emphasize that the conditions provided in the Theorem 1 abstract from the particular heterogeneity of agents – i.e. the particular functions  $\{f_{ijh}\}$  – and instead focus on the magnitude of the economic interactions across all agents, i.e. the uniform bounds on elasticities  $|\epsilon_{ijh,jh'}(x_j)| \leq (\mathbf{A})_{hh'}$ . Loosely speaking, the matrix  $(\mathbf{A})_{hh'}$  captures the degree to



which the economic outcome of any agent of type  $h'$  can impact any other agents' economic outcome of type  $h$ . Such conditions that focus on the strength of the economic interactions rather than the heterogeneity of the agents themselves are advantageous in settings where the same economic model may be applied to different empirical contexts. For example, in spatial models, the heterogeneity of agents captures such things like the specific underlying geography (e.g. trade costs) which are highly context dependent; in contrast, the elasticities govern the strength of economic interactions (e.g. the elasticity of demand) that may be similar across locations.

Part (i) of the Theorem applies Lemma 1 to show that there exists a unique solution and that solution can be computed with an iterative algorithm that converges at a rate  $\rho(\mathbf{A})$ . In particular, denote equation (2.1) as  $x = T(x)$ ; then for any initial "guess" of a positive solution  $x^0 \in \mathbb{R}_{++}^{N \times H}$ , one simply iterates  $x^1 = T(x^0)$ ,  $x^2 = T(x^1)$ ,  $x^3 = T(x^2)$ , ... until convergence. The restriction that  $f_{ijh} : \mathbb{R}_{++}^N \rightarrow \mathbb{R}_{++}$  further guarantees that the solution is strictly positive (something not guaranteed by the original Lemma).

Part (ii) of the Theorem deals with the case of  $\rho(\mathbf{A}) = 1$ , which turns out to be a common phenomenon in economic modeling (see Remark 4 below). It establishes uniqueness by imposing extra conditions on the elasticities  $\epsilon_{ih,jh'}(x_j)$ : if either the elasticities are strictly smaller than their bounds (part ii.a) or the elasticities are constant (part ii.b) then uniqueness can be assured.

Finally, since whether or not a system of the form of equation (2.1) has a unique solution in general depends on the particular specification of heterogeneity of agents, our choice to abstract from agent heterogeneity comes at the cost of preventing us from providing necessary conditions for uniqueness. Nonetheless, part (iii) of Theorem 1 shows that the conditions

provided are “globally necessary”. That is, for any matrix of elasticity bounds  $\mathbf{A}$  such that  $\rho(\mathbf{A}) > 1$ , one can construct a set functions that govern the interactions  $\{f_{ijh}\}$  with a corresponding  $\mathbf{A}$  where multiple equilibria are assured.<sup>8</sup> Such functions can be constructed even restricting attention only to functions with constant elasticities. Put another way, the sufficient conditions for uniqueness provided in the Theorem 1 are the best that can be provided when abstracting from agent heterogeneity.

### 2.2.2 Remarks

We provide below five remarks that both facilitate the implementation and extend Theorem

1. Details are presented in Online Appendix 2.5.3.

The first two remarks provide extensions to Theorem 1.

*Remark 1. (Generalized Domain)* Although above we define  $f_{ijh}(\cdot)$  as a function solely of  $x_j$ , Theorem 1 can be extended to allow  $f_{ijh}(\cdot)$  to be a function of the full set of equilibrium outcomes  $x$  for all  $j$  i.e.  $f_{ijh} : \mathbb{R}_{++}^{N \times H} \rightarrow \mathbb{R}_{++}$ . Doing so requires replacing the condition on elasticity  $|\epsilon_{ijh,jh'}(x_j)| \leq (\mathbf{A})_{hh'}$  with  $\sum_{m \in \mathcal{N}} \left| \frac{\partial \ln f_{ijh}(x)}{\partial \ln x_{mh'}} \right| \leq (\mathbf{A})_{hh'}$ . The remainder of Theorem 1 and its proof is unchanged. This generalization allows that the impact that agent  $j$  has on agent  $i$  through an interaction of type  $h$  can depend on the equilibrium outcomes of any other agents (including  $i$ 's own outcomes).

*Remark 2. (Presence of Endogenous Scalars)* In addition to equilibrium outcomes for each agent and interaction, certain economic systems also contain an endogenous scalar that

---

<sup>8</sup> Part (iii) of Theorem 1 extends the result of Allen and Donaldson (2018) to equilibrium systems with more than two equilibrium interactions (i.e.  $H > 2$ ).

reflects e.g. the aggregate welfare of the system, as in:

$$\lambda_h x_{ih} = \sum_{j=1}^N f_{ijh}(x_{j1}, \dots, x_{jH}), \quad (2.3)$$

where  $\lambda_h > 0$  is endogenous. We offer two results for such systems.

The first result concern the equilibrium system (2.3) with constant elasticities (as in Theorem 1 part(ii)b). For this form, if  $\rho(\mathbf{A}) = 1$ , we have the same conclusion as in part (ii)b: the  $\{x_{ih}\}$  of any solution is column-wise up-to-scale unique. If  $\rho(\mathbf{A}) < 1$ , it is possible to subsume the endogenous scalars into the equilibrium outcomes through a change in variables, expressing equation (2.3) as in equation (2.1), which in turn implies that the  $\{x_{ih}\}$  are column-wise up-to-scale unique. (Separating the  $\{x_{ih}\}$  and  $\{\lambda_h\}$  to determine the scale of  $\{x_{ih}\}$  requires the imposition of further equilibrium conditions, e.g. aggregate labor market clearing conditions).

The second result concerns the the equilibrium system (2.3) with  $H$  additional aggregate constraints of the form  $\sum_{i=1}^N x_{ih} = c_h$  for known constants  $c_h > 0$ . This system has a unique solution as long as  $\rho(\mathbf{A}) < \frac{1}{2}$ , where  $\mathbf{A}$  is defined as in Theorem 1. Intuitively,  $\rho(\mathbf{A}) < \frac{1}{2}$  ensures that the feedback effect from changes in the endogenous scalar are small enough to continue to ensure a contraction.

The next remark facilitates implementation of Theorem 1.

*Remark 3. (Change of variables)* It is often useful to consider a change of variables of one's original equilibrium system when writing it in the form of equation (2.1). A particularly important example that has found widespread use in spatial economics<sup>9</sup> is the following

---

9. See e.g. Eaton and Kortum (2002); Alvarez and Lucas (2007); Chaney (2008); Arkolakis et al. (2012);

economic system in which the elasticities are constant:

$$\prod_{h' \in \mathcal{H}} x_{ih'}^{\gamma_{hh'}} = \sum_{j \in \mathcal{N}} K_{ijh} \prod_{h' \in \mathcal{H}} x_{ih}^{\kappa_{hh'}} x_{jh'}^{\beta_{hh'}} . \quad (2.4)$$

for all  $i \in \mathcal{N}$  and  $h' \in \mathcal{H}$  where  $\gamma_{hh'}$ ,  $\kappa_{hh'}$ , and  $\beta_{hh'}$  are  $(h, h')$ th cells of matrix  $\mathbf{\Gamma}$ ,  $\mathbf{K}$ , and  $\mathbf{B}$ , respectively. To transform equation (2.4) to the form of equation (2.1), if  $\mathbf{\Gamma} - \mathbf{K}$  is invertible, we can redefine  $\tilde{x}_{ih} \equiv \prod_{h' \in \mathcal{H}} x_{ih'}^{\gamma_{hh'} - \kappa_{hh'}}$ . Substituting this definition into the right-hand-side we obtain  $\tilde{x}_{ih} = \sum_{j \in \mathcal{N}} K_{ijh} \prod_{h' \in \mathcal{H}} \tilde{x}_{jh'}^{\alpha_{hh'}}$ , where  $\alpha_{hh'}$  is the corresponding element of matrix  $\mathbf{B}(\mathbf{\Gamma} - \mathbf{K})^{-1}$ , which is in the form of (2.1) with  $(\mathbf{A})_{hh'} = |\alpha_{hh'}|$ . Note that a change of variables is not just analytically convenient: the presence of the absolute value operator in Theorem 1 means that a change of variables may reduce the spectral radius, making it more likely that the sufficient conditions for uniqueness are satisfied.

The last two remarks offer details about the spectral radius.

*Remark 4. (Spectral Radius of 1)* In practice,  $\rho(\mathbf{A}) = 1$  is a general phenomenon in economic systems which include nominal variables (e.g. prices). Indeed, any economic system of the form (2.4) that is homogeneous of degree 0 in at least one of its arguments will have spectral radius  $\rho(\mathbf{A})$  equal to 1 or larger. This implies that part (i) of Theorem 1 is applicable to economic systems where all economic interactions are real, whereas part (ii) of Theorem 1 is applicable to economic systems where some economic interactions are nominal.

*Remark 5. (Characterization of the Spectral Radius)* While it is straightforward to Allen and Arkolakis (2014); Redding (2016); Monte et al. (2018).

numerically calculate  $\rho(\mathbf{A})$  to apply the results of Theorem 1, analytical characterizations are also possible. We offer two results to facilitate such characterization. The first is well known: the Collatz–Wielandt Formula (e.g. see Page 670 in Meyer (2000)), implies that if the summation of each row (or column) of  $\mathbf{A}$  is less than 1, then  $\rho(\mathbf{A}) \leq 1$ .

The second is, to our knowledge, new. Define  $g(s)$  as the determinant of matrix  $sI - \mathbf{A}$  i.e.  $g(s) = |sI - \mathbf{A}|$  and denote its  $k$ -th derivative as  $g^{(k)}(s)$ . For any constant  $s > 0$ ,  $\rho(\mathbf{A}) \leq s$  if and only if  $g^{(k)}(s) \geq 0$  for all  $k = 0, 1, 2, \dots, n - 1$ .

## 2.3 Applications

In this Section, we apply Theorem 1 to provide new results to three seminal papers examining spatial networks, production networks, and social networks, respectively. For brevity, we present only a brief summary of the results here, relegating a more detailed discussion of each application to Online Appendix 2.5.4.

### 2.3.1 Spatial Networks

The first example we consider is one of a urban spatial network. We follow the seminal work of Ahlfeldt et al. (2015), where agents choose where to reside and work in a city subject to commuting costs in the presence of spatial agglomeration spillovers which decay over space. In that paper, uniqueness is proven only in the absence of these spillovers. Here, we use Theorem 1 to provide conditions for uniqueness in the presence of agglomeration spillovers. Unlike Ahlfeldt et al. (2015), however, we assume residential and commercial floor spaces are exogenously given. Interpreting the spatial network model through the lens of our

framework, an economic agent is a city block and there are three types interactions between agents: interactions through the goods market, interactions through the labor (commuting) market, and interactions through the spatial productivity spillovers. These interactions in turn determine the three types of equilibrium (strictly positive) outcomes for each agent: the residential floor price, the number of workers employed, and the productivity. As in the original paper, let  $\alpha$  denote the labor share in the production function,  $\varepsilon > 0$  denote the commuting elasticity, and  $\lambda$  denote the strength of the agglomeration spillover. Applying Theorem 1, a sufficient condition for uniqueness is  $\lambda \leq \min\left(1 - \alpha, \frac{\alpha}{1 + \varepsilon}\right)$ , i.e. uniqueness is guaranteed as long as the agglomeration spillovers are not too large and are bounded above by a combination of the land share and the commuting elasticity.

We note that this commuting model is one example of how to apply theorem Theorem 1 to spatial networks. In Online Appendix 2.5.4 we also apply Theorem 1 to (1) trade models with tariffs and and input-output interactions (extending the parameter range provided by Alvarez and Lucas (2007) where uniqueness is assured); and (2) economic geography models with agglomeration productivity spillovers that decay across space (extending the frameworks of Allen and Arkolakis (2014) and Redding (2016), where spillovers are assumed to only be local).

### **2.3.2 Production Networks**

The second example we consider is one of a sectoral production network. We follow the seminal work of Acemoglu et al. (2012), who consider a production economy where each sector uses intermediate inputs from every other sector. In that paper, the production

function is assumed to be Cobb-Douglas between labor and intermediates and Cobb-Douglas across intermediates. Here, we use Theorem 1 to provide conditions for uniqueness when we allow for a more general production function with non-unit elasticities of substitution both between labor and intermediates and across intermediates.<sup>10</sup>

Interpreting this production network through our framework, an economic agent is a sector, and the interactions are through intermediate input usage. Using Theorem 1, we can show that the equilibrium is always unique, regardless of the unit elasticity of substitution.

### 2.3.3 Social Networks

The third example we consider is one of a social network. We follow the seminal work of Brock and Durlauf (2001), where agents make a discrete choice over a set of actions and their payoffs of each actions depends on the choices on others in their social network. In that paper, conditions for uniqueness are provided when agents have a choice set of two actions and the effect of others' actions on an agent's payoffs is summarized by their mean actions. Here, we apply Theorem 1 to an extension with an arbitrary number of actions in the choice set and where the effect of others' actions on an agent's payoffs is summarized by a generalized weighted mean, where weights can be individual specific, i.e. we allow for an arbitrary social network. Unlike Brock and Durlauf (2001), however, we assume private and social component of utility are proportional rather than additive.

Through the lens of our framework, each individual in the social network is an economic agent and each of the actions in the choice set comprises a different economic interaction.

---

10. Carvalho et al. (2019) consider this general formulation and Carvalho and Tahbaz-Salehi (2019) the case with unit elasticities between labor and intermediates.

Each of these interactions in turn result in an equilibrium outcomes for each agent, which is the expected payoff of choosing each action. As in the original paper, let  $\beta$  denote the shape value of the extreme value distribution (which governs the relative importance of the random utility coefficient in agent’s payoff) and let  $J$  denote the strength of social spillovers. Applying Theorem 1, a sufficient condition for uniqueness is  $\beta J < \frac{1}{H}$  where  $H$  is the number of actions in the choice set, i.e. the greater the number of economic interactions, the weaker the social spillovers must be to ensure uniqueness.

## 2.4 Conclusion

In this note, we provide sufficient conditions for the uniqueness and computation of the equilibrium for a broad class of models with large numbers of heterogeneous agents simultaneously interacting in a large number of ways. The conditions are written in terms of the elasticities of the economic interactions across agents. These results are based on a multi-dimensional extension of the contraction mapping theorem which allows for the separate treatment of the different types of these interactions. We illustrate that a wide variety of heterogeneous agent economies – characterized by spatial, production, or social networks – yield equilibrium representations amenable to our theorem’s characterization.

By construction, the conditions provided here depend only on the uniform bound of the elasticities of agent’s interactions on each other’s outcomes rather than the particular form of the network model; that is, the conditions provided abstract from agent heterogeneity. We show that should the conditions provided not hold, there exist network models for which multiplicity is guaranteed, i.e. our conditions are “globally” necessary. However,



an outstanding and important question remains about how agent heterogeneity itself shapes the positive properties of model equilibria.

## 2.5 Appendix

### 2.5.1 Proof of Lemma 1

*Proof.* We prove that the sequence generated by the operator converges to a unique point.

To prove convergence we first prove that the sequence is a Cauchy sequence on a complete metric space. Define  $d_{max}(x, x') = \max(d(x, x'))$  as the metric in space  $X$ . Clearly  $(X, d_{max})$  is complete. Now consider any  $x \in X$ . Denote  $x^0 = x$  and for integer  $n \geq 1$   $x^n = T(x^{n-1})$ . For integers  $n$  and  $m$ , suppose  $n < m$ . We have

$$\begin{aligned}
d(x^n, x^m) &\leq d(x^n, x^{n+1}) + d(x^{n+1}, x^{n+2}) + \dots + d(x^{m-1}, x^m) \\
&< (\mathbf{A}^n + \mathbf{A}^{n+1} + \dots + \mathbf{A}^{m-1}) d(x^0, x^1) \\
&\leq (\mathbf{A}^n + \mathbf{A}^{n+1} + \dots + \mathbf{A}^{m-1} + \mathbf{A}^m + \dots) d(x^0, x^1) \\
&\leq \mathbf{A}^n (\mathbf{I} - \mathbf{A})^{-1} d(x^0, x^1). \tag{2.5}
\end{aligned}$$

Notice if  $\rho(\mathbf{A}) < 1$  then  $\mathbf{A}^n$  converges to zero matrix and  $(\mathbf{I} - \mathbf{A})^{-1}$  is finite. Furthermore, for  $n < m$ ,  $d_{max}(x^n, x^m) \rightarrow 0$  as  $n \rightarrow \infty$ . Therefore  $\{x^n\}_{n=1,2,\dots}$  is a Cauchy sequence on a complete metric space and it has a limit.

To prove existence denote the limit of the sequence  $y = \lim_{n \rightarrow \infty} x^n$  in  $X$ . We claim  $T(y) = y$ . This is because  $T(\cdot)$  is continuous, which is implied by the following formula

$$\begin{aligned}
d_{max}(T(x), T(x')) &\leq \max(\mathbf{A}d(x, x')) \\
&\leq H\bar{a} \max(d(x, x')) \\
&= H\bar{a}d_{max}(x, x')
\end{aligned}$$

where  $\bar{a}$  is the largest element of matrix  $\mathbf{A}$ . Finally, by a standard contradiction argument the point has to be unique. We thus have established convergence, existence, and uniqueness. ■

### 2.5.2 Proof of Theorem 1.

*Proof.* Define  $y = \ln x$  i.e. for any  $h \in \mathcal{H}$   $i \in \mathcal{N}$   $y_{ik} = \ln x_{ik}$ . Thus, equation (2.1) can be equivalently rewritten as  $y_{ih} = \ln \sum_{j \in \mathcal{N}} f_{ijh}(\exp y_j)$ . Denote its right side as function  $g_{ih}(y)$ , thus

$$\frac{\partial g_{ih}}{\partial y_{jh'}} = \frac{\epsilon_{ijh,jh'}(\exp y_j) f_{ijh}(\exp y_j)}{\sum_{j \in \mathcal{N}} f_{ijh}(\exp y_j)} \quad (2.6)$$

For any  $y$  and  $y'$ , according to mean value theorem, there exists some  $t_{ih} \in [0, 1]$  such that  $\hat{y} = (1 - t_{ih})y + t_{ih}y'$  satisfies for each  $i$  and  $h$

$$\begin{aligned}
g_{ih}(y) - g_{ih}(y') &= \nabla g_{ih}(\hat{y})(y - y') \\
&= \sum_{j \in \mathcal{N}, h' \in \mathcal{H}} \frac{\partial g_{ih}(\hat{y})}{\partial y_{jh'}} (y_{jh'} - y'_{jh'})
\end{aligned} \quad (2.7)$$

**Part (i):** Combine the above two equations (2.6) and (2.7) with condition  $|\epsilon_{ih,jh'}(x_j)| \leq$

$(\mathbf{A})_{hh'}$ , we have

$$\begin{aligned} |g_{ih}(y) - g_{ih}(y')| &\leq \sum_{j \in \mathcal{N}, h' \in \mathcal{H}} \frac{(\mathbf{A})_{hh'} f_{ijh}(\exp y_j)}{\sum_{j \in \mathcal{N}} f_{ijh}(\exp y_j)} |y_{jh'} - y'_{jh'}| \\ &\leq \sum_{h' \in \mathcal{H}} (\mathbf{A})_{hh'} \max_{j \in \mathcal{N}} |y_{jh'} - y'_{jh'}|. \end{aligned} \quad (2.8)$$

For any  $h \in H$ , define  $d_h(y_h, y'_h) = \max_{j \in \mathcal{N}} |y_{jh} - y'_{jh}|$  and  $Y_h = \mathbb{R}^N$ .  $d_h(\cdot, \cdot)$  is a metric on

$Y_h$ . Furthermore, define  $Y = Y_1 \times Y_2 \times \dots \times Y_H$  and  $d(y, y') = \begin{pmatrix} d_1(y_1, y'_1) \\ \dots \\ d_H(y_H, y'_H) \end{pmatrix}$  for  $y, y' \in Y$ .

Notice that inequality (2.8) then becomes  $d(g(y), g(y')) \leq \mathbf{A}d(y, y')$ . Thus we can apply Lemma 1 to obtain the desired results (existence, uniqueness and computation).

For the purpose of the computation, instead of applying the iterative procedure in the space  $Y = \mathbb{R}^{N \times H}$  according to Lemma 1, it is equivalent to do so in the space where  $x$  lies on, i.e.  $\mathbb{R}_{++}^{N \times H}$ .

**Part (ii.a):** Suppose there are two distinct solutions  $y$  and  $y'$  i.e.  $y_{ih} = g_{ih}(y)$  and  $y'_{ih} = g_{ih}(y')$ . We will arrive at a contradiction. Substitute these two solutions into equation (2.7). Also  $|\epsilon_{ih,jh'}(x_j)| < (\mathbf{A})_{hh'}$  when  $(\mathbf{A})_{hh'}$ , as long as the right side of equation (2.8) is not zero, we have

$$|y_{ih} - y'_{ih}| < \sum_{h' \in \mathcal{H}} (\mathbf{A})_{hh'} \max_{j \in \mathcal{N}} |y_{jh'} - y'_{jh'}|. \quad (2.9)$$

Thus we have  $d(y, y') \leq \mathbf{A}d(y, y')$  and the inequality strictly holds as long as the right side is not zero. Since  $y$  and  $y'$  are distinct. We must have  $d(y, y')$  as a nonzero nonnegative vector.

Thus according to the Collatz–Wielandt Formula ( $\rho(\mathbf{A}) = \max_{d \in \mathbb{R}_+, y \neq 0} \min_{\substack{1 \leq h \leq H \\ d_h \neq 0}} \frac{(\mathbf{A}d)_h}{z_h}$  Page 670 in Meyer (2000)), we have  $\rho(\mathbf{A}) > 1$ . A contradiction.

**Part (ii.b):** We will again argue by contradiction. Suppose a pair of solutions  $x$  and  $x'$  to equation (2.1) exists that are column-wise up-to-scale different. That is  $d = \begin{pmatrix} d_1 \\ \dots \\ d_H \end{pmatrix}$  is a nonzero vector where  $d_h = \min_{s \in \mathbb{R}} \max_{j \in \mathcal{N}} |y_{jh} - y'_{jh} + s|$ . For any  $h \in \mathcal{H}$ , we can suppose we have  $s_h$  and  $j_h$  such that  $d_h = |y_{j_h h} - y'_{j_h h} + s_h|$ .

Combine the above two equations (2.6) and (2.7) with condition  $\epsilon_{ih,jh'}(x_j) = \alpha_{hh'}$  where  $|\alpha_{hh'}| = (\mathbf{A})_{hh'}$ , we have

$$\begin{aligned} |g_{ih}(y) - g_{ih}(y') + \hat{s}_h| &= \left| \sum_{h' \in \mathcal{H}} \alpha_{hh'} \sum_{j \in \mathcal{N}} \frac{f_{ijh}(\exp \hat{y}_j)}{\sum_{j \in \mathcal{N}} f_{ijh}(\exp \hat{y}_j)} (y_{jh'} - y'_{jh'} + s_{h'}) \right| \\ &\leq \sum_{h' \in \mathcal{H}} |\alpha_{hh'}| d_{h'} \end{aligned} \quad (2.10)$$

where  $\hat{s}_h = \sum_{h' \in \mathcal{H}} \alpha_{hh'} s_{h'}$ . Notice that  $d_h \leq \max_{i \in \mathcal{N}} |y_{ih} - y'_{ih} + \hat{s}_h|$ . Therefore we have  $d_h \leq \sum_{h' \in \mathcal{H}} |\alpha_{hh'}| d_{h'} \leq \sum_{h' \in \mathcal{H}} (\mathbf{A})_{hh'} d_{h'}$  i.e.

$$d \leq \mathbf{A}d. \quad (2.11)$$

If  $d_h > 0$ , there there must exists  $h'$  such that  $d_{h'} > 0$  and  $\alpha_{hh'} \neq 0$ . For any  $h'$   $d_{h'} > 0$ , according to the definition of  $d_{h'}$  there must exist some  $j \in \mathcal{N}$  such that  $|y_{jh'} - y'_{jh'} + s_{h'}| < d_{h'}$ . Thus inequality (2.10) must strictly hold for all  $i \in \mathcal{N}$  whenever  $d_h > 0$ . Therefore

$d_h < \sum_{h' \in \mathcal{H}} |\alpha_{hh'}| d_{h'} \leq \sum_{h' \in \mathcal{H}} (\mathbf{A})_{hh'} d_{h'}$ . Thus, again, according to the Collatz–Wielandt Formula, we have  $\rho(\mathbf{A}) > 1$ , which is a contradiction.

**Part (iii):** Consider  $\{K_{ijh} > 0\}_{i,j \in \mathcal{N}, h \in \mathcal{H}}$  which satisfies  $\sum_{j \in \mathcal{N}} K_{ijh} = 1$  for any  $i$ . Obviously,  $x = 1$  is one solution of equation (2.4). In the following we are going to construct  $\{K_{ijh} > 0\}_{i,j \in \mathcal{N}, h \in \mathcal{H}}$  such that there exists another different solution.

As we have  $\rho(\mathbf{A}) > 1$ , suppose  $z$  is  $\mathbf{A}$ 's non-negative eigenvector such that  $\rho(\mathbf{A})z = \mathbf{A}z$ . For a given  $h$ , divide  $\mathcal{H} = \{1, 2, \dots, H\}$  into two sets  $\mathcal{H}_h^- = \{h' | \alpha_{hh'} \leq 0\}$  and  $\mathcal{H}_h^+ = \{h' | \alpha_{hh'} > 0\}$ ; also arbitrarily divide  $\mathcal{N} = \{1, 2, \dots, N\}$  into  $2H + 1$  non-empty disjoint sets  $\{\mathcal{N}_h^+, \mathcal{N}_h^-\}_{h \in \mathcal{H}}$  and  $\mathcal{N}^0$ .

Now we construct  $\bar{x} \in \mathbb{R}_{++}^{N \times H}$ . If  $j \in \mathcal{N}^0$ , for any  $h'$ ,  $\bar{x}_{jh'} = 1$ ; if  $j \in \mathcal{N}_h^+$ ,  $\bar{x}_{jh'} = \begin{cases} \exp(z_h) & h' \in \mathcal{H}_h^+ \\ \exp(-z_h) & h' \in \mathcal{H}_h^- \end{cases}$ ; if  $j \in \mathcal{N}_h^-$ ,  $\bar{x}_{jh'} = \begin{cases} \exp(-z_h) & h' \in \mathcal{H}_h^+ \\ \exp(+z_h) & h' \in \mathcal{H}_h^- \end{cases}$ . Obviously,  $\bar{x}$  is column-wise up-to-scale different from  $x$ . In below, we show there exists  $\{K_{ijh} > 0\}_{i,j \in \mathcal{N}, h \in \mathcal{H}}$  such that  $\bar{x}$  is also a solution of equation (2.1). Notice that

$$\begin{aligned}
& \sum_{j \in \mathcal{N}} K_{ijh} \prod_{h' \in \mathcal{H}} \bar{x}_{jh'}^{\alpha_{hh'}} = \\
& = \sum_{j \in \mathcal{N}_h^+} K_{ijh} \prod_{h' \in \mathcal{H}} \bar{x}_{jh'}^{\alpha_{hh'}} + \sum_{j \in \mathcal{N}_h^-} K_{ijh} \prod_{h' \in \mathcal{H}} \bar{x}_{jh'}^{\alpha_{hh'}} + \sum_{j \notin \mathcal{N}_h^+, \mathcal{N}_h^-} K_{ijh} \prod_{h' \in \mathcal{H}} \bar{x}_{jh'}^{\alpha_{hh'}} \\
& = \exp\left(\sum_{h' \in \mathcal{H}} |\alpha_{hh'}| z_{h'}\right) \sum_{j \in \mathcal{N}_h^+} K_{ijh} + \exp\left(-\sum_{h' \in \mathcal{H}} |\alpha_{hh'}| z_{h'}\right) \sum_{j \in \mathcal{N}_h^-} K_{ijh} + \\
& \quad + \sum_{j \notin \mathcal{N}_h^+ \cup \mathcal{N}_h^-} K_{ijh} \prod_{h' \in \mathcal{H}} \bar{x}_{jh'}^{\alpha_{hh'}} \tag{2.12}
\end{aligned}$$

In the last term of above equation, for any  $j \notin \mathcal{N}_h^+ \cup \mathcal{N}_h^-$ , we have  $\exp(\sum_{h' \in \mathcal{H}} |\alpha_{hh'}| z_{h'}) \geq$

$\sum_{h' \in \mathcal{H}} \bar{x}_{jh'}^{\alpha_{hh'}} \geq \exp(-\sum_{h' \in \mathcal{H}} |\alpha_{hh'}| z_h)$ . Notice that  $\exp(\sum_{h' \in \mathcal{H}} |\alpha_{hh'}| z_h) = \exp(\rho(\mathbf{A}) z_h)$  where  $\rho(\mathbf{A}) > 1$ . Therefore, we can adjust the value of  $\{K_{ijh}\}_{j \in I}$  while keeping  $\sum_{j \in \mathcal{N}} K_{ijh} = 1$  such that equation (2.12) is equal to  $\exp(z_h)$  or  $\exp(-z_h)$ . That is we have

$$\sum_{j \in \mathcal{N}} K_{ijh} \prod_{h' \in \mathcal{H}} \bar{x}_{jh'}^{\alpha_{hh'}} = \bar{x}_{ih} \text{ as desired.}$$

■

### 2.5.3 Further Details of Remarks

In this section, we provide further details for the remarks discussed in the paper.

#### Remark 1

Extending the domain of  $f_{ijh}$  to all  $x$  requires only a small change to the proof of Theorem 1,

where equality (2.6) and inequality (2.8) respectively become  $\frac{\partial g_{ih}}{\partial y_{jh'}} = \frac{\sum_m \frac{\partial \ln f_{imh}(x)}{\partial \ln x_{jh'}} f_{imh}(\exp y)}{\sum_{j \in \mathcal{N}} f_{ijh}(\exp y)}$

and

$$\begin{aligned} |g_{ih}(y) - g_{ih}(y')| &\leq \sum_{h' \in \mathcal{H}} \max_{j \in \mathcal{N}} |y_{jh'} - y'_{jh'}| \frac{\sum_{j \in \mathcal{N}} \sum_m \left[ \left| \frac{\partial \ln f_{imh}(x)}{\partial \ln x_{jh'}} \right| \right] f_{imh}(\exp y)}{\sum_{j \in \mathcal{N}} f_{ijh}(\exp y)} \\ &= \sum_{h' \in \mathcal{H}} \max_{j \in \mathcal{N}} |y_{jh'} - y'_{jh'}| \frac{\sum_m \left| \sum_{j \in \mathcal{N}} \frac{\partial \ln f_{imh}(x)}{\partial \ln x_{jh'}} \right| f_{imh}(\exp y)}{\sum_{j \in \mathcal{N}} f_{ijh}(\exp y)} \\ &\leq \sum_{h' \in \mathcal{H}} (\mathbf{A})_{hh'} \max_{j \in \mathcal{N}} |y_{jh'} - y'_{jh'}|. \end{aligned}$$

The rest of the proof of Theorem 1 remains unchanged.

**Remark 2**

Consider first the equilibrium system (2.3) with constant elasticities, which can be written as follows:

$$\lambda_h x_{ih} = \sum_{j \in \mathcal{N}} K_{ijh} \prod_{h' \in \mathcal{H}} x_{jh'}^{\alpha_{hh'}}, \quad (2.13)$$

where  $\lambda_h > 0$  is endogenous. In the case that  $\rho(\mathbf{A}) = 1$ , we have the same conclusion as in part (ii)b: the  $\{x_{ih}\}$  of any solution is column-wise up-to-scale unique. The proof of this result is exactly the same as part (ii)b of Theorem 1.

If  $\rho(\mathbf{A}) < 1$ , it is possible to subsume the endogenous scalars into the equilibrium outcomes through a change in variables, expressing equation (2.13) as in equation (2.1). To do so, define  $\tilde{x}_{ih} \equiv x_{ih} \prod_{h' \in \mathcal{H}} \lambda_{h'}^{d_{h'h}}$ , where  $d_{h'h}$  is the  $h'h^{th}$  element of the  $H \times H$  matrix  $(\mathbf{I} - \boldsymbol{\alpha})^{-1}$  and  $\boldsymbol{\alpha} \equiv (\alpha_{hh'})$  (i.e.  $\boldsymbol{\alpha}$  is the matrix of elasticities without the absolute value taken) so the system becomes:

$$\tilde{x}_{ih} = \sum_{j \in \mathcal{N}} K_{ijh} \prod_{h' \in \mathcal{H}} \tilde{x}_{jh'}^{\alpha_{hh'}}.$$

Note that because  $\rho(\mathbf{A}) < 1$ , then so too is  $\rho(\boldsymbol{\alpha}) < 1$ , so that  $(\mathbf{I} - \boldsymbol{\alpha})^{-1}$  exists. From Theorem 1 part (i), the  $\{\tilde{x}_{ih}\}$  are unique and can be calculated using an iterative algorithm, which in turn implies that the  $\{x_{ih}\}$  are column-wise up-to-scale unique. (Separating the  $\{x_{ih}\}$  and  $\{\lambda_h\}$  to determine the scale of  $\{x_{ih}\}$  requires the imposition of further equilibrium conditions, e.g. aggregate labor market clearing conditions).

Consider now equilibrium system (2.3) with  $H$  additional aggregate constraints  $\sum_{i=1}^N x_{ih} = c_h$  for known constants  $c_h > 0$ .

The second result concerns the general case with an endogenous scalar:

$$\lambda_h x_{ih} = \sum_{j=1}^N f_{ijh}(x_{j1}, \dots, x_{jH})$$

with  $H$  additional aggregate constraints  $\sum_{i=1}^N x_{ih} = c_h$  for known constants  $c_h > 0$ . Substituting in the aggregate constraints allows us to express the equilibrium system as:

$$x_{ih} = \sum_{j=1}^N \left( \frac{f_{ijh}(x_{j1}, \dots, x_{jH})}{\frac{1}{c_h} \sum_{i'=1}^N \sum_{j'=1}^N f_{i'j'h}(x_{j'1}, \dots, x_{j'H})} \right),$$

where the denominator is equal to the endogenous scalar, i.e.

$\lambda_h = \frac{1}{c_h} \sum_{i'=1}^N \sum_{j'=1}^N f_{i'j'h}(x_{j'1}, \dots, x_{j'H})$ . We can define the new function:

$$g_{ij,h}(x) \equiv \frac{f_{ijh}(x_{j1}, \dots, x_{jH})}{\frac{1}{c_h} \sum_{i'=1}^N \sum_{j'=1}^N f_{i'j'h}(x_{j'1}, \dots, x_{j'H})}$$

so that the equilibrium system becomes:

$$x_{ih} = \sum_{j=1}^N g_{ijh}(x).$$

We can then bound the elasticities, following Remark 1. Note:

$$\frac{\partial \ln g_{ij,h}}{\partial \ln x_{m,l}} = \begin{cases} \left( \frac{\partial \ln f_{ij,h}}{\partial \ln x_{j,l}} \right) \left( 1 - \frac{f_{ij}(x_{p,l})}{\sum_{o,p} f_{op}(\{x_{p,l}\})} \right) & \text{if } m = j \\ - \sum_o \left( \frac{\partial \ln f_{om,h}}{\partial \ln x_{m,l}} \right) \frac{f_{om,k}(x_{p,l})}{\sum_{o,p} f_{op,k}(\{x_{p,l}\})} & \text{if } m \neq j \end{cases}$$



so that:

$$\left| \frac{\partial \ln g_{ij,h}}{\partial \ln x_{m,l}} \right| = \begin{cases} \left| \frac{\partial \ln f_{ij,h}}{\partial \ln x_{m,l}} \right| \left( 1 - \frac{f_{ij,k}(x_{p,l})}{\sum_{o,p} f_{op}(\{x_{p,l}\})} \right) & \text{if } m = j \\ \sum_o \left| \frac{\partial \ln f_{om,h}}{\partial \ln x_{m,l}} \right| \frac{f_{om,k}(x_{p,l})}{\sum_{o,p} f_{op,k}(\{x_{p,l}\})} & \text{if } m \neq j \end{cases}$$

so that:

$$\left| \frac{\partial \ln g_{ij,h}}{\partial \ln x_{m,l}} \right| \leq \begin{cases} |A_{kh}| \left( 1 - \frac{f_{ij,k}(x_{p,l})}{\sum_{o,p} f_{op}(\{x_{p,l}\})} \right) & \text{if } m = j \\ |A_{kh}| \frac{\sum_o f_{om,k}(x_{p,l})}{\sum_{o,p} f_{op,k}(\{x_{p,l}\})} & \text{if } m \neq j \end{cases}$$

Finally, we can sum across all  $m$  locations to yield:

$$\begin{aligned} \sum_m \left| \frac{\partial \ln g_{ij,k}}{\partial \ln x_{m,l}} \right| &\leq |A_{kl}| \left( 1 - \frac{f_{ij,k}(x_{p,l})}{\sum_{o,p} f_{op}(\{x_{p,l}\})} \right) + \sum_{m \neq j} \left( |A_{kl}| \frac{\sum_o f_{om,k}(x_{p,l})}{\sum_{o,p} f_{op,k}(\{x_{p,l}\})} \right) \iff \\ \sum_m \left| \frac{\partial \ln g_{ij,k}}{\partial \ln x_{m,l}} \right| &\leq |A_{kl}| \left( 1 - \frac{f_{ij,k}(x_{p,l})}{\sum_{o,p} f_{op}(\{x_{p,l}\})} + \left( 1 - \frac{f_{ij,k}(x_{p,l})}{\sum_{o,p} f_{op}(\{x_{p,l}\})} \right) \right) \iff \\ \sum_m \left| \frac{\partial \ln g_{ij,k}}{\partial \ln x_{m,l}} \right| &\leq 2 |A_{kl}|. \end{aligned}$$

Hence, from Remark 1, we have uniqueness as long as  $\rho(\mathbf{A}) < \frac{1}{2}$ , as required.

### Remark 3

Here we provide a simple example of the claim that “The presence of the absolute value operator in Theorem 1 means that a change of variables may reduce the spectral radius, making it more likely that the sufficient conditions for uniqueness are satisfied.”

Consider the equilibrium system:

$$x_i = \sum_{j=1}^N K_{ij} x_i^{-\frac{1}{2}} x_j.$$

From Remark 1, a sufficient condition for uniqueness is that  $\sum_{m \in N} \left| \frac{\partial \ln f_{ijh}(x)}{\partial \ln x_{mh'}} \right| \leq (\mathbf{A})_{hh'} = \left| -\frac{1}{2} \right| + |1| = \frac{3}{2}$ . The transformed system  $\tilde{x}_i = \sum_{j=1}^N K_{ij} \tilde{x}_j^{\frac{2}{3}}$ , where  $\tilde{x}_i = x_i^{\frac{3}{2}}$  has a spectral radius of  $\frac{2}{3}$ . Hence, the sufficient condition for uniqueness provided from Theorem 1 is satisfied for the transformed system but not the original system.

#### Remark 4

Consider equation (2.4). We will directly prove that  $\rho(\mathbf{A}) = \rho(\mathbf{B}\mathbf{\Gamma}^{-1}) \geq 1$ . Suppose for some  $\bar{h} \geq 1$  that  $\{x_{.h}\}_{h=1, \dots, \bar{h}}$  are nominal variables. Then if we construct  $\{\bar{x}_{.h}\}_{h \in \mathcal{H}}$  by scaling  $\{x_{.h}\}_{h=1, \dots, \bar{h}}$  up to  $t$  times and keeping all other entries unchanged, the constructed  $\{\bar{x}_{.h}\}_{h \in \mathcal{H}}$  should still solve the equation. Therefore we can write

$$\mathbf{\Gamma}T = \mathbf{B}T,$$

where  $T$  is a  $H$ -by-1 vector and

$$T_h = \begin{cases} t & h \leq \bar{h} \\ 0 & \text{other case} \end{cases}.$$

Notice that this further implies  $\mathbf{\Gamma}^{-1}\mathbf{B}$  has eigenvalue of 1. Furthermore, because  $\mathbf{B}\mathbf{\Gamma}^{-1} = \mathbf{\Gamma}(\mathbf{\Gamma}^{-1}\mathbf{B})\mathbf{\Gamma}^{-1}$ ,  $\mathbf{B}\mathbf{\Gamma}^{-1}$  also has eigenvalue of 1. We define matrix  $\mathbf{A}$  as the absolute value of  $\mathbf{B}\mathbf{\Gamma}^{-1}$  (i.e. each entry of matrix  $\mathbf{A}$  is the absolute value of the corresponding entry in matrix  $\mathbf{B}\mathbf{\Gamma}^{-1}$ ). Therefore  $\rho(\mathbf{A})$  must be weakly larger than 1 because  $\rho(\mathbf{A}) = \lim_{n \rightarrow \infty} \|\mathbf{A}^n\|^{\frac{1}{n}} \geq \lim_{n \rightarrow \infty} \|(\mathbf{B}\mathbf{\Gamma}^{-1})^n\|^{\frac{1}{n}} = \rho(\mathbf{B}\mathbf{\Gamma}^{-1})$ .

## Remark 5

We prove a necessary and sufficient condition such that  $\rho(\mathbf{A}) \leq 1$ .

**Lemma 2.** *Let  $\mathbf{A}$  be a non-negative  $n \times n$  matrix. The function  $f(\lambda)$  is defined as the determinant of matrix  $\lambda I - \mathbf{A}$  i.e.  $f(\lambda) = |\lambda I - \mathbf{A}|$ , and its  $k$ -th derivative is denoted by  $f^{(k)}(\lambda)$ . Then  $\rho(\mathbf{A}) \leq s$  if and only if  $f^{(k)}(s) \geq 0$  for all  $k = 0, 1, 2, \dots, n-1$ .*

*Proof. If part:* Notice that  $f^{(n)}(s) = n! > 0$ . Then  $f^{(n-1)}(\lambda)$  strictly increases with  $\lambda$ . So  $f^{(n-1)}(\lambda) > 0$  for  $\lambda \in [s, \infty)$ . Using deduction we obtain  $f(\lambda)$  is strictly increasing and  $f(\lambda) \geq 0$  for any  $\lambda \in [s, \infty]$ . According to Perron–Frobenius theorem,  $\rho(\mathbf{A})$  is  $\mathbf{A}$ 's largest eigenvalue, so that  $f(\rho(\mathbf{A})) = 0$ . Thus, by strict monotonicity it must be  $\rho(\mathbf{A}) \leq s$ .

**Only If part:** According to the Fundamental Theorem of Algebra (e.g. see Corollary 3.6.3 of Fine and Rosenberger (1997)),  $f(\lambda)$  can be decomposed as  $f(\lambda) = f_1(\lambda) f_2(\lambda)$  such that  $f_1(\lambda) = \prod_{i \in C} (\lambda - \lambda_i) (\lambda - \bar{\lambda}_i)$  and  $f_2(\lambda) = \prod_{i \in R} (\lambda - \lambda_i)$  where  $\bar{\lambda}_i$  is conjugate of  $\lambda_i$  and  $C$  and  $R$  are set of indexes. For all  $i \in C$ ,  $\lambda_i$  is a complex number and for all  $i \in R$   $\lambda_i$  is a real number. Clearly,  $\lambda_i$  and  $\bar{\lambda}_i$  are eigenvalues of  $\mathbf{A}$ . Notice that  $f^{(k)}(\lambda) = \sum_{(k_1, k_2) \in D_k} f_1^{(k_1)}(\lambda) f_2^{(k_2)}(\lambda)$  where  $D_k = \{k_1, k_2 | k_1 + k_2 = k, k_1, k_2 \geq 0\}$ . When  $i \in R$   $\lambda_i \leq \rho(\mathbf{A})$  (from Perron–Frobenius theorem), we have  $f_2^{(k_2)}(s) \geq 0$ . Additionally,  $f_1^{(k_1)}(\lambda) =$

$\prod_{i \in C} [\lambda^2 - (\lambda_i + \bar{\lambda}_i) \lambda + \lambda_i \bar{\lambda}_i]^{(k_{2,i})}$  where  $k_{2,i} \geq 0$  and  $\sum_{i \in C} k_{2,i} = k_2$ . Notice that

$$[s^2 - (\lambda_i + \bar{\lambda}_i) s + \lambda_i \bar{\lambda}_i]^{(k_{2,i})} = \begin{cases} s^2 - (\lambda_i + \bar{\lambda}_i) s + \lambda_i \bar{\lambda}_i > 0 & k_{2,i} = 0 \\ 2(s - \operatorname{Re}(\lambda_i)) & k_{2,i} = 1 \\ 2 > 0 & k_{2,i} = 2 \\ 0 & k_{2,i} > 3 \end{cases},$$

where  $\operatorname{Re}(\lambda_i)$  is real part of  $\lambda_i$ . As  $\operatorname{Re}(\lambda_i) < \|\lambda_i\| \leq \rho(\mathbf{A}) \leq s$  (the second inequality is also from Perron–Frobenius theorem), so  $[s^2 - (\lambda_i + \bar{\lambda}_i) s + \lambda_i \bar{\lambda}_i]^{(k_{2,i})} \geq 0$ . In all,  $f^{(k)}(s) \geq 0$   $k = 0, 1, 2, \dots, n - 1$ . ■

## 2.5.4 Applications

In this section, we provide more detail for the three examples discussed in Section 2.3.

### Spatial Networks

The first set of applications is examples where interactions across heterogeneous agents take place in space. We consider an urban model (extending the results of Ahlfeldt et al. (2015)), an economic geography model (extending the results of Allen and Arkolakis (2014)), and a trade model (extending the results of Alvarez and Lucas (2007)) in turn.

**Urban Model** Here we prove the uniqueness of the quantitative urban framework of Ahlfeldt et al. (2015) with endogenous agglomeration spillovers but assume residential and

commercial land are exogenously given. In terms of our framework, each city block is a different economic agent and there are three different economic interactions, each represented by an equilibrium condition. The first economic interaction is through the goods market, where we require the goods markets clear, i.e. the income in a city block is equal to its total sales:

$$I_i = \sum_{j=1}^S K_{ij} Q_i^{-\epsilon(1-\beta)} w_j^{1+\epsilon} \quad (2.14)$$

where  $I_i = \frac{Q_i H_{Ri}}{\beta}$  is the total income of the residents living in location  $i$ ,  $Q_i$  is the rental price in location  $i$ ,  $w_j$  is the wage in location  $j$ , and  $K_{ij} = \Phi^{-1} T_i E_j d_{ij}^{-\epsilon} H > 0$  is a matrix incorporating the commuting costs between locations.

The second economic interaction is through the labor (commuting) market, where we require that the total number of agents working in a location,  $H_{Mi}$ , is equal to the number of workers choosing to commute there, i.e.:

$$H_{Mi} = \sum_{j=1}^S K_{ji} Q_j^{-\epsilon(1-\beta)} w_i^\epsilon, \quad (2.15)$$

Finally, the third economic interaction is through the spatial productivity spillover, where the productivity of a city block depends on the density of nearby workers, i.e.:

$$A_i^{\frac{1}{\lambda}} = a_i^{\frac{1}{\lambda}} \sum_{j=1}^S \frac{e^{-\delta\tau_{ij}}}{K_j} H_{Mj}. \quad (2.16)$$

Given the assumed Cobb-Douglas production function and the assumed fixed amount of land in each location used for production, we substitute  $w_i = \alpha A_i H_{Mi}^{\alpha-1} L_{Mi}^{1-\alpha}$  into above

equations to create three equilibrium conditions that are a function of three outcomes: the price of residential land, the number of agents working in a location, and the productivity of a location. Observe that equations above are of the form of equation 2.4 with  $\{Q_i, H_{Mi}, A_i\}_{i=1,\dots,S}$

as endogenous outcome variables.<sup>11</sup> And the corresponding  $\mathbf{\Gamma}$  and  $\mathbf{B}$  are respectively

$$\begin{pmatrix} 1 + \epsilon(1 - \beta) & 0 & 0 \\ 0 & 1 + \epsilon(1 - \alpha) & -\epsilon \\ 0 & 0 & \frac{1}{\lambda} \end{pmatrix} \text{ and } \begin{pmatrix} 0 & (\alpha - 1)(1 + \epsilon) & 1 + \epsilon \\ -\epsilon(1 - \beta) & 0 & 0 \\ 0 & 1 & 0 \end{pmatrix}. \text{ Then}$$

we have

$$\mathbf{A} = \begin{pmatrix} 0 & \frac{(1-\alpha)(1+\epsilon)}{1+\epsilon(1-\alpha)} & \frac{\lambda(1+\epsilon)}{1+\epsilon(1-\alpha)} \\ \frac{\epsilon(1-\beta)}{1+\epsilon(1-\beta)} & 0 & 0 \\ 0 & \frac{1}{1+\epsilon(1-\alpha)} & \frac{\lambda\epsilon}{1+\epsilon(1-\alpha)} \end{pmatrix}.$$

Recall from Remark 5 that if the summation of each row of  $\mathbf{A}$  is less than 1, then we have  $\rho(\mathbf{A}) \leq 1$ . Specifically, from Theorem 1(i),  $\mathbf{A}x \leq x$  holds as long as  $\lambda \leq \min\left(1 - \alpha, \frac{\alpha}{1+\epsilon}\right)$ , as claimed.

**Economic Geography Model** We now consider the framework of Allen and Arkolakis (2014). The model yields the same mathematical equilibrium system as in Redding (2016) and Allen et al. (2014) and thus the results apply in all these models. We extend that framework to allow for productivity spillovers that decay over space of the form:

$$A_i = \bar{A}_i \sum_{j=1}^N K_{ij}^A L_j^\alpha,$$

---

11. Although  $\Phi$  is also an endogenous variable, it is not location specific. Treating it exogenously is equivalent with the equilibrium. (The equivalence can be shown by scaling  $\{Q_i, H_{Mi}, A_i\}_{i=1,\dots,S}$ .)

where  $A_i$  represents the productivity of region  $i$ ,  $\bar{A}_i$  its exogenous component and  $L_i$  the labor in region  $i$  that is determined in equilibrium.  $K_{ij}^A$  represents spatial spillovers in productivity and  $\alpha$  the spillover elasticity that is common across locations. Furthermore, appropriately replacing the equilibrium conditions (corresponding to equations 10 and 11 of Allen and Arkolakis (2014) that represent interactions through trade and the labor market) we obtain:

$$L_i A_i^{1-\sigma} w_i^\sigma = W^{1-\sigma} \sum_{j=1}^N T_{ij}^{1-\sigma} \bar{u}_j^{\sigma-1} L_j^{1+\beta(\sigma-1)} w_j^\sigma$$

$$L_i^{\beta(1-\sigma)} w_i^{1-\sigma} = W^{1-\sigma} \sum_{j=1}^N T_{ji}^{1-\sigma} \bar{u}_i^{\sigma-1} A_j^{\sigma-1} w_j^{1-\sigma},$$

where  $w_i$  is the wage in location  $i$ ,  $\bar{u}_i$  the exogenous amenity,  $\beta$  the local amenity spillover elasticity and  $\sigma$  the demand elasticity.  $T_{ij}$  represents the matrix of trade costs to ship goods across locations.<sup>12</sup>

We can write the parametric matrices corresponding to Theorem 1 as

$$\mathbf{\Gamma} = \begin{pmatrix} 1 & 1-\sigma & \sigma \\ \beta(1-\sigma) & 0 & 1-\sigma \\ 0 & 1 & 0 \end{pmatrix}, \mathbf{B} = \begin{pmatrix} 1+\beta(\sigma-1) & 0 & \sigma \\ 0 & \sigma-1 & 1-\sigma \\ \alpha & 0 & 0 \end{pmatrix}.$$

Therefore,

$$\mathbf{\Gamma}^{-1} = \begin{pmatrix} 1 & \frac{\sigma}{\sigma-1} & \sigma-1 \\ \beta(\sigma-1) & \beta\sigma & 1+\beta(\sigma-1)^2 \\ 0 & -\frac{1}{\sigma-1} & 0 \end{pmatrix}$$

---

12. Overall amenity of living in a location  $i$  is  $u_i = \bar{u}_i L_i^\beta$ , i.e. it depends on local population. The amenity is assumed to affect welfare of a location multiplicatively.

and

$$\mathbf{B}\Gamma^{-1} = \begin{pmatrix} 1 + \beta(\sigma - 1) & \beta\sigma & \sigma - 1 + \beta(\sigma - 1)^2 \\ \beta(\sigma - 1)^2 & \beta\sigma(\sigma - 1) + 1 & \sigma - 1 + \beta(\sigma - 1)^3 \\ \alpha & \frac{\alpha\sigma}{\sigma - 1} & \alpha(\sigma - 1) \end{pmatrix}.$$

We consider the case that  $\beta < 0 < \alpha$  which allows for the spectral radius to be less or equal than one. The case  $\alpha, \beta \geq 0$  always implies a spectral radius bigger than one. When  $\beta < 0$  the first two rows of  $\mathbf{B}\Gamma^{-1}$  may be negative. Notice that  $(\sigma - 1)(\mathbf{B}\Gamma^{-1})_{22} < (\sigma - 1)(\mathbf{B}\Gamma^{-1})_{11} = (\mathbf{B}\Gamma^{-1})_{13}$  and  $(\sigma - 1)(\mathbf{B}\Gamma^{-1})_{22} < (\mathbf{B}\Gamma^{-1})_{23}$ . There is a number of cases to discuss. Here we only consider the case  $(\mathbf{B}\Gamma^{-1})_{22} \geq 0$ ; other cases can be derived similarly.

If  $(\mathbf{B}\Gamma^{-1})_{22} > 0$  i.e.  $\beta > -\frac{1}{\sigma(\sigma - 1)}$ , then we have

$$|\mathbf{B}\Gamma^{-1}| = \begin{pmatrix} 1 + \beta(\sigma - 1) & -\beta\sigma & \sigma - 1 + \beta(\sigma - 1)^2 \\ -\beta(\sigma - 1)^2 & \beta\sigma(\sigma - 1) + 1 & \sigma - 1 + \beta(\sigma - 1)^3 \\ \alpha & \frac{\alpha\sigma}{\sigma - 1} & \alpha(\sigma - 1) \end{pmatrix}.$$

A sufficient condition for  $\rho(|\mathbf{B}\Gamma^{-1}|) \leq 1$  is that the summation of each column is smaller than 1 (see Remark 5). Thus we have

$$\alpha + \beta(\sigma - 1)(2 - \sigma) \leq 0$$

$$\frac{\alpha\sigma}{\sigma - 1} + \beta\sigma(2 - \sigma) \leq 0$$

$$\alpha + \beta\sigma(\sigma - 1) \leq \frac{1}{\sigma - 1} - 2.$$

The three inequalities and  $\beta > -\frac{1}{\sigma(\sigma - 1)}$  can guarantee  $\rho(|\mathbf{B}\Gamma^{-1}|) \leq 1$  and, therefore,



uniqueness.

**Trade Model with Tariffs** We now analyze the celebrated Ricardian model developed by Eaton and Kortum (2002) specified with tariffs and input-output network as in Alvarez and Lucas (2007).

The equilibrium of their model can be characterized by the three equations below (corresponding to equations 3.8, 3.15, and 3.17 respectively in Alvarez and Lucas (2007)),

$$p_{mi} = \left[ \sum_{j=1}^n \lambda_j \left( \frac{1}{\kappa_{ij}} \frac{AB}{\omega_{ij}} \right)^{-\theta} \left( w_j^\beta p_{mj}^{1-\beta} \right)^{-\theta} \right]^{-\frac{1}{\theta}}, \quad (2.17)$$

$$L_i w_i (1 - s_{fi}) = \sum_{j=1}^n L_j \frac{w_j (1 - s_j^f)}{F_j} D_{ji} \omega_{ji}, \quad (2.18)$$

$$F_i = \sum_{j=1}^n D_{ij} \omega_{ij}, \quad (2.19)$$

where  $D_{ij} \equiv \frac{(w_j^\beta p_j^{1-\beta})^{-\theta}}{p_{mi}^{-\theta}} \left( \frac{AB}{\kappa_{ij} \omega_{ij}} \right)^{-1/\theta} \lambda_j$  is country  $i$ 's per capita spending on tradeables that is spent on goods from country  $j$  and  $s_i^f = \frac{\alpha[1-(1-\beta)F_i]}{(1-\alpha)\beta F_i + \alpha[1-(1-\beta)F_i]}$  is labor's share in the production of final goods (equations 3.10 and 3.16 in Alvarez and Lucas (2007)) and the endogenous variables are:  $p_{mi}$ , the price index of tradeables in country  $i$ ;  $F_i$ , the fraction of country  $i$ 's spending on tradeables that reaches producers; and  $w_i$ , country  $i$ 's wage. Finally,  $\omega_{ij}$  is the bilateral tariff.

Now we show how to transform the equilibrium equations into the form of equation (2.4). First, raise both sides of equation (2.17) to the power of  $-\theta$  and denote  $\lambda_j \left( \frac{1}{\kappa_{ij}} \frac{AB}{\omega_{ij}} \right)^{-\theta}$  as

$K_{ij}^1$ , then we can rewrite equation (2.17) as

$$p_{mi}^{-\theta} = \sum_{j=1}^n K_{ij}^1 w_j^{-\beta\theta} p_{mj}^{-(1-\beta)\theta}; \quad (2.20)$$

Second, substitute the expression of  $D_{ij}$  into equation (2.19), multiply both sides by  $p_{mi}^{-\theta}$ , and denote  $\omega_{ij} \lambda_j \left( \frac{1}{\kappa_{ij}} \frac{AB}{\omega_{ij}} \right)^{-\theta}$  as  $K_{ij}^2$ , then we can rewrite equation (2.19) as

$$p_{mi}^{-\theta} F_i = \sum_{j=1}^n K_{ij}^2 w_j^{-\beta\theta} p_{mj}^{-(1-\beta)\theta}; \quad (2.21)$$

Third, define  $\tilde{F}_i \equiv \alpha + (\beta - \alpha) F_i$ , substitute equation (2.19) into it, and notice that  $\sum_{j=1}^n D_{ij} = 1$ . Thus we have  $\tilde{F}_i = \sum_{j=1}^n D_{ij} [\alpha + (\beta - \alpha) \omega_{ij}]$ . Again, substitute the expression of  $D_{ij}$ , multiply both sides by  $p_i^{-\theta}$ , and denote  $[\alpha + (\beta - \alpha) \omega_{ij}] \lambda_j \left( \frac{1}{\kappa_{ij}} \frac{AB}{\omega_{ij}} \right)^{-\theta}$  as  $K_{ij}^3$ , then we can have equation

$$p_{mi}^{-\theta} \tilde{F}_i = \sum_{j=1}^n K_{ij}^3 w_j^{-\beta\theta} p_{mj}^{-(1-\beta)\theta} \quad (2.22)$$

Last, substitute the expressions of  $s_{fi}$  and  $D_{ji}$  into equation (2.18), subsequently replace  $\alpha + (\beta - \alpha) F_i$  with  $\tilde{F}_i$ , multiply both sides by  $p_{mi}^{(1-\beta)\theta} w_i^{\beta\theta}$  and define  $\frac{L_j}{L_i} \omega_{ji} \lambda_j \left( \frac{1}{\kappa_{ij}} \frac{AB}{\omega_{ij}} \right)^{-\theta}$  as  $K_{ij}^4$ , then we can rewrite equation (2.18) as

$$p_{mi}^{(1-\beta)\theta} F_i \tilde{F}_i^{-1} w_i^{1+\beta\theta} = \sum_{j=1}^n K_{ij}^4 w_j \tilde{F}_j^{-1} p_{mj}^{\theta}. \quad (2.23)$$

Now we have transformed the equilibrium equations into the form (2.4) but with four set of endogenous variables  $\left\{ p_{mi}, F_i, \tilde{F}_i, w_i \right\}_{i=1,2,\dots,n}$ . Notice that all the kernels,  $K_{ij}^1, \dots, K_{ij}^4$ , defined above are positive when  $\alpha, \beta, \theta > 0$  and  $0 < \omega_{ij} \leq 1$ . Then we have the corresponding

parameter matrices

$$\Gamma = \begin{pmatrix} -\theta & 0 & 0 & 0 \\ -\theta & 1 & 0 & 0 \\ -\theta & 0 & 1 & 0 \\ (1-\beta)\theta & 1 & 1 & 1+\beta\theta \end{pmatrix}, \mathbf{B} = \begin{pmatrix} -(1-\beta)\theta & 0 & 0 & -\beta\theta \\ -(1-\beta)\theta & 0 & 0 & -\beta\theta \\ -(1-\beta)\theta & 0 & 0 & -\beta\theta \\ \theta & 0 & -1 & 1 \end{pmatrix}$$

The determinant of  $\Gamma$  is  $-\frac{1}{\beta\theta^2+\theta} \neq 0$ . This implies  $\Gamma$  is always invertible as long as  $\theta > 0$ .

Therefore, we have

$$|\mathbf{B}\Gamma^{-1}| = \begin{pmatrix} 1-\beta & 0 & 0 & \beta \\ 0 & 0 & 0 & 0 \\ 0 & 0 & 0 & 0 \\ \frac{1-(1-\beta)^2}{\beta+1/\theta} & 0 & \frac{1}{\beta\theta+1} & \frac{|1-(1-\beta)\beta\theta|}{\beta\theta+1} \end{pmatrix}$$

Here  $1 \geq \theta(1-\beta)\beta$  or  $\beta \geq \frac{1}{2}$  is sufficient for  $\rho(|\mathbf{B}\Gamma^{-1}|) \leq 1$  i.e. we have (up-to-scale) uniqueness. In comparison, the essential conditions for uniqueness in Alvarez and Lucas (2007) are i)  $(\min_{i,j=1,2,\dots,n} \{\kappa_{ij}\} \min_{i,j=1,2,\dots,n} \{\omega_{ij}\})^{\frac{2}{\theta}} \geq 1-\beta$ ; ii)  $\alpha \geq \beta$ ; iii)  $1 - \min_{i,j=1,2,\dots,n} \{\omega_{ij}\} \leq \frac{\theta}{\alpha-\beta}$  (see their Theorem 3).<sup>13</sup>

## Production Networks

We next study economic interactions that arise from from input-output production linkages.

---

13. If  $1 \geq \theta(1-\beta)\beta$ , we can solve explicitly the eigenvalues are  $\left\{ 0, 0, 1, \frac{(1-\beta)-\beta\theta}{1+\beta\theta} \right\}$ . Obviously,  $\left| \frac{(1-\beta)-\beta\theta}{1+\beta\theta} \right| < 1$ , thus the uniqueness holds. If  $1 < \theta(1-\beta)\beta$ , the characteristic polynomial is  $f(x) = x^4 + \frac{2\beta^2-2\beta+\beta/\theta}{\beta+1/\theta}x^3 + \frac{2\beta^3-4\beta^2+\beta+\beta/\theta-1/\theta}{\beta+1/\theta}x^2$ . According to Lemma 2, we can check the value of  $f^{(k)}(1)$  for  $k = 0, 1, 2, 3$ , a sufficient condition to guarantee  $\rho(|\mathbf{B}\Gamma^{-1}|) \leq 1$  is  $\beta \geq \frac{1}{2}$ . (In this case the sufficient and necessary condition is  $4\beta^3 - 2\beta^2 + 2/\theta + 5\beta/\theta \geq 0$  and  $2\beta^3 + 2\beta^2 + \beta + 4\beta/\theta - 1/\theta \geq 0$  when  $1 < \theta(1-\beta)\beta$ .)

## Constant Elasticity Among Intermediates

We first consider a direct extension of the framework by Acemoglu et al. (2012) where the production function is Cobb-Douglas in labor and intermediates. Instead, we assume that intermediates across all sectors are aggregated through a constant elasticity of substitution aggregator different sectors with an elasticity  $\sigma$ . This extension is explicitly discussed in Carvalho and Tahbaz-Salehi (2019) as a special case of the nested CES case considered by Baqaee and Farhi (2018). Formally the production function is

$$y_i = z_i l_i^{\alpha_1} \left[ \left( \sum_j x_{ji}^{\frac{\sigma-1}{\sigma}} \right)^{\frac{\sigma}{\sigma-1}} \right]^{\alpha_2}$$

where  $z_i$  stands for the productivity and is exogenous,  $l_i$  is the labor,  $x_{ji}$  is the intermediate goods from sector  $j$ , and  $\alpha_1 + \alpha_2 = 1$ .

Therefore, from cost minimization we have the price of the goods produced in sector  $i$

$$p_i = \frac{\bar{\alpha}}{z_i} w^{\alpha_1} (P_i)^{\alpha_2} \quad (2.24)$$

where we define  $\bar{\alpha} = \alpha_1^{\alpha_1} \alpha_2^{\alpha_2}$ ,  $w$  is the wage, and the price index of intermediate goods  $P_i$  is determined in the following equation

$$P_i^{1-\sigma} = \sum_j \tau_{ji}^{1-\sigma} p_j^{1-\sigma} \quad (2.25)$$

where  $\tau_{ji}$  stands for the standard iceberg trade cost but can be interpreted here as the cost of adaption of the good as an intermediate in another sector. Substitute the expression of

$p_j = \frac{\bar{\alpha}}{z_j} w^{\alpha_1} P_j^{\alpha_2}$  (equation (2.24)), into (2.25) we immediately obtain

$$P_i^{1-\sigma} = \sum_j \left( \frac{\bar{\alpha}}{z_j} w^{\alpha_1} \right)^{1-\sigma} \tau_{ji}^{1-\sigma} P_j^{\alpha_2(1-\sigma)}. \quad (2.26)$$

Normalize the wage  $w$  to be 1. Notice that since  $z_i$  is exogenous, this equation (for all  $i$ ) determines the price indexes  $\{P_i\}$ . Therefore, as long as consumer utility function satisfies concavity condition, this equation alone can represent the equilibrium. Define  $x_i \equiv P_i^{1-\sigma}$  and  $f_{ij}(x_j) \equiv \left( \frac{\bar{\alpha}}{z_j} w^{\alpha_1} \right)^{1-\sigma} \tau_{ji}^{1-\sigma} x_j$ , thus the above equation is the form of equation (2.1). We immediately have  $\frac{\partial \ln f_{ij}}{\partial \ln x_j} = \alpha_2$ , so uniqueness and convergence of an iterative operator require  $|\alpha_2| < 1$ , which is satisfied as long as labor is used in production.

**Constant Elasticity Between Intermediates and Factors** We now consider the generalization of the production networks setup in Acemoglu et al. (2012) as discussed in Carvalho et al. (2019) to incorporate constant elasticity of substitution between intermediate goods.

Consider a static economy consisting of  $n$  competitive firms denoted by  $\{1, 2, \dots, n\}$ , each of which producing a distinct product. Firms employ nested CES production technology

$$y_i = \left[ \chi (1 - \mu)^{\frac{1}{\sigma}} (z_i l_i)^{\frac{\sigma-1}{\sigma}} + \mu^{\frac{1}{\sigma}} M_i^{\frac{\sigma-1}{\sigma}} \right]^{\frac{\sigma}{\sigma-1}}$$

where  $l_i$  is the amount of labor,  $z_i$  is the (exogenous) labor productivity, and the intermediate

input bundle  $M_i$  is a CES aggregate of inputs purchased from other firms:

$$M_i = \left[ \sum_{j=1}^n a_{ij}^{\frac{1}{\zeta}} x_{ij}^{\frac{\zeta-1}{\zeta}} \right]^{\frac{\zeta}{\zeta-1}}.$$

We remark that Carvalho et al. (2019) also include firm-specific capital in the production function; however, given that it is assumed to be supplied inelastically, it is isomorphic to the exogenous labor productivity term  $z_i$ .

Solving the cost minimization problem of the firm results in the following system of equations for equilibrium prices:

$$p_i^{1-\sigma} = (1-\mu)(z_i w)^{1-\sigma} + \mu \left( \sum_{m=1}^n a_{sm} p_m^{1-\zeta} \right)^{\frac{1-\sigma}{1-\zeta}}$$

which in turn can be written as:

$$\left( \frac{p_i^{1-\sigma} - (1-\mu)(z_i w)^{1-\sigma}}{\mu} \right)^{\frac{1-\zeta}{1-\sigma}} = \sum_{m=1}^n a_{sm} p_m^{1-\zeta}.$$

Normalizing the wage  $w = 1$  and defining  $x_i \equiv \left( \frac{p_i^{1-\sigma} - (1-\mu)(z_i w)^{1-\sigma}}{\mu} \right)^{\frac{1-\zeta}{1-\sigma}}$ , this becomes:

$$x_i = \sum_{j=1}^N a_{ij} \left( \mu x_j^{\frac{1-\sigma}{1-\zeta}} + (1-\mu) z_j^{1-\sigma} \right)^{\frac{1-\zeta}{1-\sigma}},$$

which is a special case of equation (2.1) with  $f_{ij} \equiv a_{ij} \left( \mu x_j^{\frac{1-\sigma}{1-\zeta}} + (1-\mu) (z_j)^{1-\sigma} \right)^{\frac{1-\zeta}{1-\sigma}}$ .

Note that:

$$\frac{\partial \ln f_{ij}}{\partial \ln x_j} = \left( \frac{1-\zeta}{1-\sigma} \right) \left( \frac{1-\sigma}{1-\zeta} \right) \frac{\mu x_j^{\frac{1-\sigma}{1-\chi}}}{\mu x_j^{\frac{1-\sigma}{1-\chi}} + (1-\mu)(z_j)^{1-\sigma}} \implies$$

$$\left| \frac{\partial \ln f_{ij}}{\partial \ln x_j} \right| = \frac{\mu x_j^{\frac{1-\sigma}{1-\chi}}}{\mu x_j^{\frac{1-\sigma}{1-\chi}} + (1-\mu)(z_j)^{1-\sigma}} < 1,$$

so that by Theorem 1 (part ii.a), there exists at most one equilibrium.

## Social Networks

Here we consider a discrete choice framework with social interactions as in Brock and Durlauf (2001), generalized to include a choice set of more than two actions. Suppose there are  $N$  individuals where each individual  $i \in \{1, \dots, N\}$  chooses from a set of  $H$  actions, where  $h_i \in \{1, \dots, H\}$  indicates her choice. Let the  $N$ -tuple  $\boldsymbol{\omega} \equiv \{h_1, \dots, h_N\}$  denote the actions by entire population and let  $\boldsymbol{\omega}_{-i}$  denote the actions of all individuals except  $i$ .

Let agent  $i$ 's payoffs for choosing action  $h$  consists of three components:

$$V_{ih} = u_{ih} + S_{ih}(\boldsymbol{\omega}_{-i}) + \varepsilon_{ih},$$

where  $u_{ih}$  is the private utility associated with choice  $h$ ,  $S_{ih}(\boldsymbol{\omega}_{-i})$  is the social utility associated with the choice, and  $\varepsilon_{ih}$  is a random utility term, independently and identically distributed across agents. In equilibrium, an agent will choose the action  $h_i$  that maximizes her payoffs given the actions of others, i.e:

$$h_i(\boldsymbol{\omega}_{-i}) \equiv \arg \max_{h \in \{1, \dots, H\}} V_{ih}(\boldsymbol{\omega}_{-i}).$$

Define  $\mu_{ijh}$  to be the conditional probability measure agent  $i$  places on the probability that agent  $j$  chooses action  $h$ . We assume that  $S_{ih}(\boldsymbol{\omega}_{-i})$  takes the following form:

$$S_{ih}(\boldsymbol{\omega}_{-i}) = J \ln \left( \left( \sum_{j \neq i} \omega_{ij,h} (\mu_{ijh})^\eta \right)^{\frac{1}{\eta}} \right),$$

where  $J$  governs the strength of the social interaction,  $\omega_{ij,h}$  (normalized so that  $\sum_{j \neq i} \omega_{ij,h} = 1$ ) are weights that agent  $i$  places on agent  $j$ 's choice of action  $h$  to capture heterogeneity in the social network connections, and the parameter  $\eta \in (-\infty, \infty)$  determines what type of mean aggregation is used across other individuals (e.g.  $\eta = -\infty$  is the minimum,  $\eta = -1$  is the harmonic mean;  $\eta = 0$  is the geometric mean;  $\eta = 1$  is the arithmetic mean; and  $\eta = \infty$  is the maximum). We note that the log transform on the social utility function – not present in the primary case considered by Brock and Durlauf (2001) – ensures that the uniqueness of the equilibrium can be characterized without reference to an (endogenous) threshold value (c.f. Brock and Durlauf (2001) Proposition 2).

The presence of weights  $\omega_{ij,h}$  and the flexibility of the particular mean function (governed by parameter  $\eta$ ) – both of which are absent in the particular functional forms characterized by Brock and Durlauf (2001) – allow for flexible social interactions between individuals in the network. However, the uniqueness conditions provided below turn out to only depend on the strength of the social interaction  $J$ . Note that without loss of generality we can define the private utility as follows  $u_{ih} \equiv \ln v_{ih}$ , which allows us to interpret  $J$  as the parameter which governs the extent to which social interactions determine the choice of agents. A value of  $J = 0$  means that decisions are only made by private considerations of utility, whereas a value  $J = 1$  means that social utility and private utility  $v_{ih}$  are given equal proportions in



the utility function.

Retaining the assumption from Brock and Durlauf (2001) that the random utility term follows an extreme value distribution with shape parameter  $\beta$  and agent's conditional probabilities are rational (so that  $\mu_{ijh} = \mu_{jh}$  for all  $j \in \{1, \dots, N\}$  and  $\mu_{jh}$  is equal to the probability agent  $j$  actually chooses action  $h$ ) results in the following equilibrium conditions for all  $i \in \{1, \dots, N\}$  and for all  $h \in \{1, \dots, N\}$ :

$$\mu_{ih} = \frac{\exp(\beta u_{ih}) \times \left( \left( \sum_{j \neq i} \omega_{ij,h} (\mu_{jh})^\eta \right)^{\frac{1}{\eta}} \right)^{J\beta}}{\sum_{k=1}^H \exp(\beta u_{ik}) \times \left( \left( \sum_{j \neq i} \omega_{ij,k} (\mu_{jk})^\eta \right)^{\frac{1}{\eta}} \right)^{J\beta}} \quad (2.27)$$

Note this is a system of  $N \times H$  equilibrium conditions in  $N \times H$  unknown probabilities  $\mu_{jh}$ .

Equation (2.27) is a special case of (2.1). To see this, define  $y_{ih} \equiv \mu_{ih}^{\frac{\eta}{J\beta}}$ , so that equation (2.27) becomes:

$$y_{ih} = \frac{\exp\left(\frac{\eta}{J} u_{ih}\right) \times \sum_{j \neq i} \omega_{ij,h} y_{jh}^{J\beta}}{\left( \sum_{k=1}^H \left( \sum_{l \neq i} \exp\left(\frac{\eta}{J} u_{ik}\right) \omega_{il,k} y_{lk}^{J\beta} \right)^{\frac{J\beta}{\eta}} \right)^{\frac{\eta}{J\beta}}}$$

Furthermore, define  $x_{ih} \equiv \sum_{l \neq i} \exp\left(\frac{\eta}{J} u_{il}\right) \omega_{il,h} y_{lh}^{J\beta}$  so that equation (2.27) becomes:

$$y_{ih} = \frac{x_{ih}}{\left( \sum_{k=1}^H x_{ik}^{\frac{J\beta}{\eta}} \right)^{\frac{\eta}{J\beta}}}.$$

Then given the definition of  $x_{ih}$ , we have:

$$x_{ih} = \sum_{j \neq i} \exp\left(\frac{\eta}{J} u_{ih}\right) \omega_{ij,h} \left( \frac{x_{jh}}{\left(\sum_{k=1}^H x_{jk}^{\frac{J\beta}{\eta}}\right)^{\frac{\eta}{J\beta}}} \right)^{J\beta}. \quad (2.28)$$

Finally, defining  $f_{ijh} \equiv \exp\left(\frac{\eta}{J} u_{ih}\right) \omega_{ij,h} \left( \frac{x_{jh}}{\left(\sum_{k=1}^H x_{jk}^{\frac{J\beta}{\eta}}\right)^{\frac{\eta}{J\beta}}} \right)^{J\beta}$  if  $j \neq i$  and  $f_{iih} = 0$  results in equation (2.28) be written as:

$$x_{ih} = \sum_{j=1}^N f_{ijh}(x_{j1}, \dots, x_{jH}),$$

as in (2.1). It is straightforward to provide bounds on the elasticities of interactions as follows:

$$\frac{\partial \ln f_{ij,h}}{\partial \ln x_{j,h}} = J\beta \left( 1 - \frac{x_{jh}^{\frac{J\beta}{\eta}}}{\sum_{k=1}^H x_{jk}^{\frac{J\beta}{\eta}}} \right) \in [0, \beta J]$$

and, for  $h' \neq h$ :

$$\frac{\partial \ln f_{ij,h}}{\partial \ln x_{j,h'}} = -J\beta \left( \frac{x_{jh'}^{\frac{J\beta}{\eta}}}{\sum_{k=1}^H x_{jk}^{\frac{J\beta}{\eta}}} \right) \in [-\beta J, 0]$$

So that if we define:

$$(\mathbf{A})_{hh'} \equiv \beta J$$

then we have for all  $h, h'$ :

$$\left| \frac{\partial \ln f_{ij,h}}{\partial \ln x_{j,h'}} \right| \leq (\mathbf{A})_{hh'}$$

Since the largest eigenvalue of a constant positive square matrix is that constant divided by

the number of rows, Theorem 1(i) implies that we have uniqueness as long as  $\beta J < \frac{1}{H}$ . Hence, as the size of agent's choice set increases, guaranteeing uniqueness requires increasingly weak social spillovers.

## 2.5.5 Additional Remarks

### Footnote 4

Here we illustrate the importance of treating the endogenous as  $H$  vectors with  $N$  elements instead of one giant variable with  $NH$  elements. To focus on the ideas, we set  $N = 1$ . Consider the below example:

$$x_{11} = x_{11}^{\frac{1}{2}} x_{12}^2 + 1$$

$$x_{12} = x_{12}^{\frac{1}{2}} + 1$$

(Here, in order to be consistent with the paper, we do not suppress the notation of  $N$ .)

We show when the system is treated as a single  $2 \times 1$  vector, it is not a contraction. We consider its log transformation by setting  $y_1 = \ln x_{11}$  and  $y_2 = \ln x_{12}$ . Thus the above two equations become:

$$y_1 = \ln \left( e^{\frac{1}{2}y_1 + 2y_2} + 1 \right) \tag{2.29}$$

$$y_2 = \ln \left( e^{\frac{1}{2}y_2} + 1 \right). \tag{2.30}$$

Denote its right side as  $T(\cdot) : \mathbb{R}^2 \rightarrow \mathbb{R}^2$ . Its Jacobian matrix is

$$J(y) = \begin{pmatrix} \frac{1}{2} \frac{e^{\frac{1}{2}y_1+2y_2}}{e^{\frac{1}{2}y_1+2y_2}+1} & \frac{2e^{\frac{1}{2}y_1+2y_2}}{e^{\frac{1}{2}y_1+2y_2}+1} \\ 0 & \frac{1}{2} \frac{e^{\frac{1}{2}y_2}}{e^{\frac{1}{2}y_2}+1} \end{pmatrix}.$$

Notice that the tight upper bound of the Jacobian matrix is

$$\mathbf{A} = \begin{pmatrix} \frac{1}{2} & 2 \\ 0 & \frac{1}{2} \end{pmatrix}.$$

For two  $y$  and  $y'$ , applying the mean value theorem on the two single-valued functions of  $T(\cdot)$ , we have

$$|T(y) - T(y')| \leq \mathbf{A} |y - y'| \quad (2.31)$$

To apply the standard contraction mapping, we treat  $y_1$  and  $y_2$  as a single vector variable. We consider two natural choices of norms to serve for the metric used in the contraction mapping: 1. the max norm  $\|y\|_{\max} = \max(y_1, y_2)$ ; 2. the Euclidean norm  $\|y\| = \sqrt{y_1^2 + y_2^2}$ .

For the first norm, according to inequality (2.31), we have

$$\|T(y) - T(y')\|_{\max} \leq 2 \|y - y'\|_{\max}.$$

Clearly, the standard contraction mapping does not apply.

For the second norm, again according to inequality (2.31), we have

$$\|T(y) - T(y')\| \leq \|\mathbf{A}\| \|y - y'\|$$

where  $\|\mathbf{A}\|$  is the  $\mathbf{A}$ 's matrix norm. Here  $\|\mathbf{A}\| \approx 2.118$ . Again, the standard contraction mapping does not apply.

In contrast, applying our multi-dimension contraction mapping, we treat  $y_1$  and  $y_2$  as two separate variables. We immediately have  $\rho(\mathbf{A}) = \frac{1}{2}$ , so that inequality (2.31) implies the uniqueness.

# Chapter 3

## Optimal City Structure

with Treb Allen and Costas Arkolakis

## 3.1 Introduction

As of 2014, 54% of people worldwide live in cities. This is an increase from 34% in 1960, and urban population is expected to increase by more than 1% per year in the upcoming decades. This unprecedented concentration is indicative of the large agglomeration economies that take place in shorter distances and lead firms and individuals to cluster in cities. While local governments have a large array of potential policy tools at their disposal (e.g. zoning policies, subsidies, infrastructure projects, etc.), little is known about how a city can best take advantage of these agglomeration economies in order to improve the welfare of its citizens.

In this paper, we develop a quantitative general equilibrium model of a city that incorporates the agglomeration forces within the city and allows us to examine the welfare effects of zoning policies. Our model has three key ingredients. First, following a large literature on the economics of the city we assume that agents make commuting choices (see e.g. Anas and Kim (1996), Anas and Rhee (2006), Ahlfeldt et al. (2012)) i.e. they choose where to live and work. Second, we assume that there are spatial spillovers of productivity. Specifically, the productivity in one location may depend on the distribution of agents working within the city. Last, we assume that firms produce the good using commercial buildings and labor as perfectly complementary inputs and agents have Cobb-Douglas preferences over residential buildings and the good. Among the above three ingredients, agents' commuting choices are the nexus connecting the rest of the model; spatial spillovers of productivity imply that agents' commuting choices have externality and open up the possibility for interventions by the city planner to be welfare improving; and since residential and commercial building can affect agent's commuting choices, zoning policies can serve as tools for the city planner to

correct the externality. Despite the rich interplay among its different ingredients, the model remains tractable. In particular, we present two sets of results that facilitate the use of this model to evaluate zoning policies.

The first set (Proposition 1) is about the positive aspect of the model. We prove that for any zoning policy that allocates the aggregate residential and commercial buildings, there always exists a competitive equilibrium allocating the rest of resources. While this result is not surprising, it is reassuring that zoning policy is compatible with the rest of the market despite many spatial linkages present in the model. The second set (Proposition 2) is about the normative aspect of the model. We assign the city planner to maximize agents' average utility. When there are no spatial spillovers, we show that the market is the same with the city planner. This ensures that compared with the market, the difference of the city planner does not lie in redistribution but only efficiency. We then consider how the city planner can improve welfare and provide an explicit formula to evaluate the welfare effect of zoning policy in practice.

Our approach is related with the standard general equilibrium analysis of welfare used in trade and geography models (see, for example, Arkolakis et al. (2012) and Allen and Arkolakis (2014)). Also, our model is connected with urban models where residential and working locations are separated by commuting frictions (see Fujita and Ogawa (1982), Lucas and Rossi-Hansberg (2003), Ahlfeldt et al. (2012), Anas and Kim (1996), Anas and Rhee (2006) and Ioannides (2013) for a comprehensive review). We contribute to this literature by adding an actual geography of the city (as in Ahlfeldt et al. (2012)) and in addition by providing the apparatus to characterize the equilibrium of the model as well as the planner so as to analyze local policy interventions. Finally, our work is also related to a urban literature



that analyzes optimal spatial policy use in the presence of externalities, reviewed in Glaeser and Gottlieb (2008). Closer to our approach, Turner et al. (2014) evaluate the effect of land use regulation on the value of land use and on welfare. The authors exploit cross-border changes in development, prices, and regulation in regions near municipal borders together with detailed data on the land use and regulations.

The remainder of the paper is organized as follows: in the next section, we present the theoretical model. In Section 3, we present our formal results. Section 4 concludes.

## 3.2 Model

This section describes the theoretical model. The premise of the model is similar to the canonical Alonso-Mills-Muth model (Alonso et al. (1964), Mills (1967), Muth (1969) see Ioannides (2013) ch. 5 for a description) and in particular we assume individuals have preferences over good consumption and housing and their income is determined by their working productivity and time. We assume a perfectly competitive good market with firms that use land and labor to produce. Now we proceed to formally introduce the model.

### 3.2.1 Model Setup

We consider a city consisting of a set of locations  $\Theta = \{1, 2, \dots, N\}$  that we denote with subscripts  $i$  or  $j$ . There is a building endowment  $H_i > 0$  at each location  $i \in \Theta$  which can be put in residential,  $H_{Ri} \geq 0$ , or commercial use,  $H_{Ci} \geq 0$ ,

$$H_{Ri} + H_{Ci} \leq H_i.$$

There are two types of players in the city: firms and agents. Firms organize production only within commercial area i.e. locations where there are positive commercial building; agents live and consume in residential area and work in commercial area.

## Agents

Let  $\Omega$  be the set of all agents and  $\mu(\cdot)$  be the measure defined in set  $\Omega$ .  $\mu(\Omega)$  represents the number of population. Throughout this paper, we denote  $\mu(\Omega)$  as  $\bar{L}$ . Agents live and consume in residential area and work in commercial area. Agents can only live in one location and work in one location. But agents do not have to work and live in the same location.

Agents have the same preferences. The utility function used to represent their preference is Cobb-Douglas

$$u = u_i q^\beta h^{1-\beta},$$

where  $u_i$  stands for amenity of location  $i$  where the agent lives;  $q$  is the good consumed by the consumer;  $h$  is the quantity of housing the agent consumes; and  $\beta \in (0, 1)$ .

The only heterogeneity agents have is their location-specific productivity. Agent  $\omega$ 's productivity  $a(\omega) = [a_j(\omega)]_{j \in \Theta} \in \mathbb{R}_{++}^N$ , where  $a_j(\omega)$  stands for  $\omega$ 's productivity in location  $j$ . Regarding the distribution of productivity  $a(\omega)$ , we follow Eaton and Kortum (2002) and Ahlfeldt et al. (2012). Specifically, we assume that the idiosyncratic productivity,  $a_j(\omega)$ , follows a Frechet distribution with shape parameter  $\theta$ , i.e.  $Pr[a_j(\omega) \leq u] \sim e^{-u^{-\theta}}$ . We also assume  $a_j(\omega)$  is independent across different working places, i.e.  $a_j(\omega) \perp a_k(\omega)$  for any  $j \neq k, j, k \in \Theta$ .

The agent has one unit of time that can be used to work. If agent  $\omega$  chooses to live in  $i$

and work in  $j$ , she has  $t_{ij} \equiv 1 - d_{ij}$  unit of time left working, where  $d_{ij}$  represents the time spent in commuting. Therefore, her wage income in total is

$$w_j a_j(\omega) t_{ij}$$

where  $w_j$  is the wage at location  $j$  for agents with productivity 1 working one unit time.

Every agent equally owns all the residential and commercial buildings and therefore receives the same capital income  $k$ , which will be defined later. Thus her total income is

$$y = k + w_j a_j(\omega) t_{ij}.$$

The timing of agents making decisions is as follows. Agents first choose where to live; they then observe their idiosyncratic location-specific productivity; they finally decide where to work and how to consume. Therefore, in below we use backward induction to solve the agent's problem.

**Solving The Agent's Problem** **First**, given the agent's total income  $y$  and the choice that she chooses to live at location  $i$ , the agent maximizes her utility coming from consumption i.e.

$$\max_{q,h} q^\beta h^{1-\beta} \tag{3.1}$$

subject to

$$pq + r_{Ri}h \leq y, \tag{3.2}$$

where  $p$  and  $r_{Ri}$  are the price of good and rent of residential housing at location  $i$  respectively. The Cobb-Douglas preference over the consumption good and housing implies that the agent spends a constant share of income  $\beta$  in the consumption good and  $1 - \beta$  in housing. Thus we have the indirect expression of total consumption as

$$c \frac{y}{p^\beta r_{Ri}^{1-\beta}}$$

where  $c = \beta^\beta (1 - \beta)^{1-\beta}$  (For convenience of notation, in the following we omit the constant, as it does not affect agent's decision).

**Second**, given the realized productivity  $a(\omega)$  and the choice that she chooses to live at location  $i$ , the agent chooses where to work by maximizing her total consumption, which is equivalent to maximize her total income i.e.  $\max_{j \in \Theta} k + w_j a_j(\omega) t_{ij}$ . Clearly, the agent just needs to maximize her wage income. Thus the agent chooses to work at locations from

$$\arg \max_{j \in \Theta} w_j a_j(\omega) t_{ij}.$$

**Last**, the agent chooses to live in the place that provides the largest ex ante utility i.e.  $\max_{i \in \Theta} \mathbb{E} \left[ u_i \frac{k + \max_{j \in \Theta} w_j a_j(\omega) t_{ij}}{p^\beta r_{Ri}^{1-\beta}} \right]$ . The macro variables including  $w_j$ ,  $p$ , and  $r_{Ri}$  can be determined in equilibrium. Therefore, the agent can take them as given and only form beliefs over her wage income  $\max_{j \in \Theta} w_j a_j(\omega) t_{ij}$ . Using the Frechet distribution, we can obtain its expectation as (the detailed calculation is in the appendix)

$$\mathbb{E} \left[ \max_{j \in \Theta} w_j a_j(\omega) t_{ij} \right] = \Gamma \left( \frac{\theta - 1}{\theta} \right) W_i,$$

where  $W_i = \left( \sum_j (w_j t_{ij})^\theta \right)^{\frac{1}{\theta}}$ . Thus the agent chooses to live at locations from

$$\arg \max_{i \in \Theta} u_i \frac{k + \Gamma \left( \frac{\theta-1}{\theta} \right) W_i}{p^\beta r_{Ri}^{1-\beta}}.$$

## Firms

Firms produce goods in commercial area. We assume all firms at location  $j$  have the same production function

$$q = A_j \min(l, h).$$

where  $A_j$  is firm's productivity,  $l$  is the effective units of labor, and  $h$  is the amount of commercial building rented. We assume the goods and input market are perfectly competitive. Therefore, firms solve the below problem

$$\max_{l, h} pq - w_j l - r_{Cj} h, \tag{3.3}$$

where  $p$  is the price of goods;  $w_j$  is the wage of per effective unit labor; and  $r_{Cj}$  is the rent of commercial building in location  $i$ . We have the solution of firm's problem

$$\begin{cases} l = h = 0 & pA_j < w_j + r_{Cj} \\ l = h \geq 0 & pA_j = w_j + r_{Cj} \\ l, h = \infty & pA_j > w_j + r_{Cj} \end{cases} \tag{3.4}$$

### 3.2.2 Aggregation

Having determined the behavior of each agent and firm individually, we next turn to aggregating individual decisions to the level of the city.

**Agent Side** First, since we assume all agents hold an equal share of all the buildings, agents capital income  $k$  satisfies the below equation

$$\sum_{i \in \Theta} r_{Ri} H_{Ri} + \sum_{j \in \Theta} r_{Cj} H_{Cj} = k\bar{L}. \quad (3.5)$$

Second, we have the summation of all residents is equal to the total population

$$\sum_i L_{Ri} = \bar{L}. \quad (3.6)$$

Third, the fact that agents are homogeneous when they choose where to live implies that (ex-ante) welfare is equalized over all the residential locations i.e.

$$U = \frac{u_i y_i}{p^\beta r_{Ri}^{1-\beta}}. \quad (3.7)$$

where  $U$  stand for ex-ante welfare of the agents and total income  $y_i = k + \Gamma \left( \frac{\theta-1}{\theta} \right) W_i$  with  $W_i = \left( \sum_j (w_j t_{ij})^\theta \right)^{\frac{1}{\theta}}$ .

Fourth, from agent's problem (3.1), we know the share of the total rent in the total expenditure is  $1 - \beta$ , thus we have

$$r_{Ri} H_{Ri} = (1 - \beta) y_i L_{Ri}. \quad (3.8)$$

Last, we have the total income

$$y_i = k + \Gamma \left( \frac{\theta - 1}{\theta} \right) W_i \quad (3.9)$$

with  $W_i = \left( \sum_j (w_j t_{ij})^\theta \right)^{\frac{1}{\theta}}$ .

**Firm Side** First, the solution of firm's problem imply that at the city level, we have

$$w_j + r_{Cj} = pA_j$$

and

$$\begin{cases} w_j = pA_j & L_{Ej} < H_{Cj} \\ 0 \leq w_j \leq pA_j & L_{Ej} = H_{Cj} \\ w_j = 0 & L_{Ej} > H_{Cj} \end{cases} \quad (3.10)$$

where  $L_{Ej}$  is the total supply of effective units of labor and  $H_{Cj}$  is the total commercial building at location  $j$ .

Second,  $L_{Ej}$  the total supply of effective units of labor is a summation of effective units coming from different residential areas

$$L_{Ej} = \sum_{i \in \Theta} t_{ij} l_{ij} L_{Ri}$$

where  $l_{ij} \equiv \int_0^\infty a_j f(a_j) da_j \prod_{k \neq j} \int_0^{\frac{a_j w_j t_{ij}}{w_k t_{ik}}} f(a_k) da_k$  represents the total productivity coming from  $i$  to  $j$  if there is one unit of agents living at  $i$ ,  $f(a) = \theta a^{-\theta-1} \exp(-a^{-\theta})$  is the

probability density function of Frechet distribution with shape parameter  $\theta$ , and  $L_{Ri}$  is the total population living at location  $i$ . Here,  $l_{ij}L_{Ri}$  is the total productivity of agents commuting from  $i$  to  $j$ . Here when  $\theta > 1$  (meaning the heterogeneity is large enough),  $l_{ij}$  is finite and it can be explicitly calculated as (the calculation is in the appendix)

$$l_{ij} = g \left( \frac{(w_j t_{ij})^\theta}{\sum_k (w_k t_{ik})^\theta} \right)^{\frac{\theta-1}{\theta}}$$

where  $g = \Gamma\left(\frac{\theta-1}{\theta}\right)$  is a constant. Therefore,

$$L_{Ej} = \sum_{i \in \Theta} g t_{ij} \left( \frac{(w_j t_{ij})^\theta}{\sum_k (w_k t_{ik})^\theta} \right)^{\frac{\theta-1}{\theta}} L_{Ri}. \quad (3.11)$$

Third, we consider spatial spillovers of productivity in the following form

$$A_i = \bar{A}_i \sum_j K_{ij} L_{wj}^\eta \quad (3.12)$$

where  $\bar{A}_i > 0$ ,  $K_{ij} > 0$ , and constant  $\eta$  are exogenously given, and  $L_{wj} = \min(L_{Ej}, H_{Cj})$  represents the effective units of labor who actually work in location  $j$ . This formulation is in line with Lucas and Rossi-Hansberg (2003) and Rossi-Hansberg (2005), the endogenous interaction of agents with others implies that there are external benefits to producers from production done nearby.

Last, if the market determines the allocation of residential and commercial buildings, we have for any  $j \in \Theta$

$$H_{Rj} + H_{Cj} = H_j \quad (3.13)$$



and

$$\begin{cases} r_{Rj} = r_{Cj} & H_{Rj}, H_{Cj} > 0; \\ r_{Rj} < r_{Cj} & H_{Rj} = 0; \\ r_{Rj} > r_{Cj} & H_{Cj} = 0. \end{cases} \quad (3.14)$$

### 3.3 Equilibrium and Welfare Analysis

In this section, we define the market equilibrium and setup the zoning planner and present the equilibrium and welfare analysis.

**Definition 2.** In a **Market Equilibrium**, all the resources are allocated through the market. It is mathematically represented by real variables  $\{H_{Rj}, H_{Cj}, A_j, L_{Rj}, L_{Ej}\}_{i \in \Theta}$ , price variables  $\{r_{Rj}, r_{Cj}, w_j, y_j\}_{i \in \Theta}$ , and  $\{p, k, U\}$  which are determined in equations (3.5)-(3.14).

Observe that in a market equilibrium, the total number of variables is  $9N + 3$ . They correspond to the  $9N + 2$  equations and a price normalization condition.

**Definition 3.** A **Zoning Planner** allocates the aggregate residential and commercial buildings  $\{H_{Ci}, H_{Ri}\}_{i \in \Theta}$  and the rest allocation is completed through market. Particularly equations (3.5)-(3.12) determine variables  $\{A_j, L_{Rj}, L_{Ej}\}_{i \in \Theta}$ ,  $\{r_{Rj}, r_{Cj}, w_j, y_j\}_{i \in \Theta}$ , and  $\{p, k, U\}$ .

#### 3.3.1 Equilibrium Analysis

Now we state the existence result of the market equilibrium and zoning planner.

**Proposition 1.** *i). The market equilibrium has a solution i.e. there exists  $\{H_{Rj}, H_{Cj}, A_j, L_{Rj}, L_{Ej}\}_{i \in \Theta}$ ,  $\{r_{Rj}, r_{Cj}, w_j, y_j\}_{i \in \Theta}$ , and  $\{p, k, U\}$  such that equations (3.5)-(3.14) hold.*

ii). Given any zoning plan  $\{H_{Ci}, H_{Ri}\}_{i \in \Theta}$  satisfying  $\sum_i H_{Ci} > 0$  and  $\sum_i H_{Ri} > 0$ , there exists  $\{A_j, L_{Rj}, L_{Ej}\}_{i \in \Theta}$ ,  $\{r_{Rj}, r_{Cj}, w_j, y_j\}_{i \in \Theta}$ , and  $\{p, k, U\}$  such that equations (3.5)-(3.12) hold.

*Proof.* Here we explain the main ideas of the proof and leave details in the appendix. The proof is based on Brouwer’s fixed point theorem. There are two challenges in applying the fixed point theorem. First, equations (3.7), (3.10) and (3.14) involve corner conditions and therefore cannot directly serve as an operator used in Brouwer’s fixed point theorem; second, some variables may go unbounded whereas Brouwer’s fixed point theorem require the domain of variables to be compact. The two types of challenges are not new and have been dealt in literature. Particularly, in order to prove the existence of equilibrium points in non-cooperative game, Nash (1951) develops a technique to deal with the first challenge by embedding the equilibrium equations in a dynamic system which can serve as an operator; the literature of general equilibrium deal with the second challenge by considering the equilibrium in a large bounded set (“box”) and then show that for a fixed point cannot be at the boundary of the box. And the nature of our proof is to synthesize the two techniques and apply them multiple times since in our model the two challenges show up in several places. ■

This proposition illustrates that the characterization of the properties of the equilibrium of urban models with spatial spillovers can be generalized beyond particular examples. Theories that feature technological spillovers across space (see for example Fujita and Ogawa (1982), Lucas and Rossi-Hansberg (2003), Rossi-Hansberg (2005), Fujita and Thisse (2013) chapter 6) usually assume a particular geography (e.g. line or circle) and structure for trade costs or impose a restriction on the spillover matrix  $K_{ij}$ , and also typically assumed

particular values for the spillover elasticity,  $\eta = 0$  or  $\eta = 1$ . In contrast, Proposition 1 proves that an equilibrium always exists for any  $\eta$  and for any matrix  $K_{ij}$  governing technological diffusion across space.

### 3.3.2 Welfare Analysis

Now we turn to compare the welfare difference between the market equilibrium and zoning planner. Toward this end, we need to assign an objective function for the zoning planner to maximize. Consider the below one

$$\max_{\{H_{Ci}, H_{Ri}\}_{i \in \Theta}} U \quad (3.15)$$

subject to

$$H_{Rj} + H_{Cj} \leq H_j. \quad (3.16)$$

In below, we shall compare the expected utility of agents  $U$  under the market equilibrium and zoning planner. However, it is difficult to directly compare. Therefore, we consider a social planner as a benchmark who has a greater power than both the market equilibrium and zoning planner. Formally, we have the below definition.

**Definition 4. A Social Planner** not only directly allocates the aggregate residential and commercial buildings  $\{H_{Ci}, H_{Ri}\}_{i \in \Theta}$  but also determines all the rest allocations subject to some constraints. Particularly, the social planner organizes the production, dictates  $L_{Ri}$  i.e. how many agents live in location  $i$ , and allocates the goods and residential buildings to each agent according to a linear rule, specifically, an agent gets  $q_i + q_{ij}l$  units goods and  $h_i + h_{ij}l$

units of residential housing if an agent commutes from  $i$  to  $j$  and can effectively work  $l$  hours.

The social planner considers the below problem

$$\max_{\{H_{Ci}, H_{Ri}, L_{Ri}, q_i, h_i, q_{ij}, h_{ij}\}_{i \in \Theta}} U \quad (3.17)$$

subject to equations (3.6) and (3.16), the constraint that given the linear allocation rule, agents maximizing utilities in determining their commuting choices (denote  $\Omega_i$  as the set of agents choosing to live at location  $i$  and  $\Omega_{ij} = \left\{ \omega \in \Omega_i \mid j = \arg \max_{j \in \Theta} a_j(\omega) q_{ij}^\beta h_{ij}^{1-\beta} \right\}$  a the set of people commuting from  $i$  to  $j$ ), and the residential housing and goods constraints

$$h_i L_{Ri} + \sum_j \int_{\omega \in \Omega_{ij}} h_{ij} t_{ij} a_j(\omega) \mu(d\omega) \leq H_{Rj}$$

and

$$\sum_i q_i L_{Ri} + \sum_{ij} \int_{\omega \in \Omega_{ij}} q_{ij} t_{ij} a_j(\omega) \mu(d\omega) \leq \sum_j A_j \min(L_{Ej}, H_{Cj})$$

where  $L_{Ri} = \mu(\Omega_i)$ ,  $L_{Ej} = \sum_i t_{ij} \int_{\omega \in \Omega_{ij}} a(\omega) \mu(d\omega)$ , and

$$U = \max_{i \in \Theta} \mathbb{E} \left[ u_i \left( q_i^\beta h_i^{1-\beta} + \max_{j \in \Theta} \mathbb{E} a_j(\omega) q_{ij}^\beta h_{ij}^{1-\beta} \right) \right].$$

**Proposition 2.** *When  $\eta = 0$ , the solution(s) of both the zoning and social planners can be implemented via the market equilibrium. Specifically, equations (3.5)-(3.14) have a solution that also solves problems (3.17) and (3.15).*

*Proof.* Details are in the appendix. ■

When there are no spatial spillovers, Proposition 2 states that in our model, the market equilibrium can reach the same goal of the zoning and social planners. It is related with but

shall not be confused with the typical welfare theorems. The First Welfare Theorem cannot be readily applied in our model because of our timing assumption and the fact that there is no insurance markets (incomplete market). This result is more closed with the Second Welfare Theorem but in our market equilibrium agents' endowments are fixed, specifically, they equally own all the buildings. This proposition ensures that compared with the market, the difference of the zoning planner does not lie in redistribution but only efficiency.

When there are spatial spillovers, agents' location choices have externality. While a typical remedy to correct the externality is Pigou tax, in practice, Pigou tax may not be a feasible policy tool e.g. a city planner may not be able to subsidize workers in one neighborhood/block but not in another. We may need to consider other policy tools. Observe that the allocation  $\{H_{Ci}, H_{Ri}\}_{i \in \Theta}$  of residential and commercial building can affect agent's commuting choices. Thus, the zoning policy may, to some extent, correct the externality. Particularly, in equation 3.12,  $L_{wj} = \min(L_{Ej}, H_{Cj})$ . If  $H_{Cj}$  is the binding variable, the marginal increment of productivity in location  $i$  caused by  $H_{Cj}$  then is  $\eta \bar{A}_i K_{ij} L_{wj}^{\eta-1}$ . Aggregate this effect across all location  $i$  and multiply with the price and inputs, we have its (partial equilibrium) welfare effect<sup>1</sup> as

$$r_{Cj} + \kappa_j$$

where  $\kappa_j = \eta p L_{wj}^{\eta-1} \sum_i \bar{A}_i K_{ij} \min(L_{Ei}, H_{Ci})$ . At the same time, the opportunity cost of increasing one unit  $H_{Cj}$  is the benefit of increasing one unit  $H_{Rj}$ , which is measured by  $r_{Rj}$ . Therefore, in practice, we can use  $r_{Cj} + \kappa_j - r_{Rj}$  to evaluate zoning policy at location  $j$ .

---

1. As shown in our proof, the nominal variables are directly linked with the objective function of welfare.

## 3.4 Conclusion

In this paper, we develop a general equilibrium model of city. Despite the many spatial linkages, the model allows for characterizing the existence of the spatial equilibrium of the city even when the spillovers are much more general than what is usually considered in literature. We consider a city planner whose different with the market does not lie in redistribution but only efficiency. One shortcoming of this paper is that we are not able to provide a sharp characterization of the optimal zoning policy when there are spatial spillovers. This reflects a general difficulty in policy decision-making. Its mathematical nature is how to optimize subject to a high-dimension fixed point problem.

## 3.5 Appendix

### 3.5.1 Derivation of expected wage income and productivity

In this appendix, we derive the expression of expected income  $\mathbb{E}[\max_{j \in \Theta} w_j a_j(\omega) t_{ij}]$  and productivity  $l_{ij}$ .

Since  $a_j(\omega)$  follows Frechet distribution i.e.  $Pr[a_j(\omega) \leq u] \sim \exp(-u^{-\theta})$ , denote its density function as  $f(u) = \theta u^{-\theta-1} \exp(-u^{-\theta})$ . Thus we have

$$\begin{aligned}
\mathbb{E} \left[ \max_{j \in \Theta} w_j a_j(\omega) t_{ij} \right] &= \sum_j \int_0^\infty w_j t_{ij} a_j f(a_j) da_j \prod_{k \neq j} \int_0^{\frac{a_j w_j t_{ij}}{w_k t_{ik}}} f(a_k) da_k \\
&= \int_0^\infty w_j t_{ij} a_j^\theta a_j^{-\theta-1} \exp(-a_j^{-\theta}) da_j \exp\left(-\sum_{k \neq j} \left(\frac{a_j w_j t_{ij}}{w_k t_{ik}}\right)^{-\theta}\right) \\
&= \int_0^\infty \theta w_j t_{ij} a_j^{-\theta} \exp(-a_j^{-\theta}) \exp\left(-a_j^{-\theta} \frac{\sum_k (w_k t_{ik})^\theta}{(w_j t_{ij})^\theta}\right) da_j.
\end{aligned}$$

Denote  $c_{ij} = \left(\frac{(w_j t_{ij})^\theta}{\sum_k (w_k t_{ik})^\theta}\right)^{\frac{1}{\theta}}$ . We have

$$\mathbb{E} \left[ \max_{j \in \Theta} w_j a_j(\omega) t_{ij} \right] = \sum_j w_j t_{ij} \int_0^\infty \theta a_j^{-\theta} \exp\left(-(c_{ij} a_j)^{-\theta}\right) dv_j.$$

Notice that

$$\begin{aligned}
\int_0^\infty \theta a_j^{-\theta} \exp\left(-(c_{ij} a_j)^{-\theta}\right) da_j &= \frac{c_{ij}^\theta}{c_{ij}} \int_0^\infty \theta (c_{ij} a_j)^{-\theta} \exp\left(-(c_{ij} a_j)^{-\theta}\right) dc_{ij} a_j \\
&= c_{ij}^{\theta-1} \int_0^\infty \theta y^{-\theta} \exp(-y^{-\theta}) dy \\
&= c_{ij}^{\theta-1} \int_0^\infty x^{-\frac{1}{\theta}} \exp(-x) dx
\end{aligned}$$

where in the last two steps we use two changes of variables:  $y = c_{ij} a_j$  and  $x = y^{-\theta}$ . Notice that Gamma function is defined as  $\Gamma(t) = \int_0^\infty x^{t-1} \exp(-x) dx$ . Thus  $\int_0^\infty x^{-\frac{1}{\theta}} \exp(-x) dx =$

$\Gamma\left(\frac{\theta-1}{\theta}\right)$ . Combine the above two equations we have

$$\begin{aligned}\mathbb{E}\left[\max_{j \in \Theta} w_j a_j(\omega) t_{ij}\right] &= \Gamma\left(\frac{\theta-1}{\theta}\right) \sum_j w_j t_{ij} c_{ij}^{\theta-1} \\ &= \Gamma\left(\frac{\theta-1}{\theta}\right) \sum_j w_j t_{ij} \left(\frac{(w_j t_{ij})^\theta}{\sum_k (w_k t_{ik})^\theta}\right)^{\frac{\theta-1}{\theta}} \\ &= \Gamma\left(\frac{\theta-1}{\theta}\right) \left(\sum_j (w_j t_{ij})^\theta\right)^{\frac{1}{\theta}}\end{aligned}$$

as desired.

Notice that the above derivation has already given the value of expected productivity

$$\begin{aligned}l_{ij} &\equiv \int_0^\infty a_j f(a_j) da_j \prod_{k \neq j} \int_0^{\frac{a_j w_j t_{ij}}{w_k t_{ik}}} f(a_k) da_k \\ &= \int_0^\infty \theta a_j^{-\theta} \exp\left(- (c_{ij} a_j)^{-\theta}\right) da_j \\ &= \Gamma\left(\frac{\theta-1}{\theta}\right) c_{ij}^{\theta-1} = \Gamma\left(\frac{\theta-1}{\theta}\right) \left(\frac{(w_j t_{ij})^\theta}{\sum_k (w_k t_{ik})^\theta}\right)^{\frac{\theta-1}{\theta}}.\end{aligned}$$

### 3.5.2 Proof of Proposition 1

*Proof. Part i).*

The proof is based on Brouwer's fixed point theorem. We need to construct a suitable operator.

First, consider the operator for  $H_{Ci}$ ,  $H_{Ri}$ ,  $A_j$ , and  $L_{Ri}$ .

$$H'_{Ci} = \frac{H_{Ci} + \max(0, D_{ri}) H_j}{1 + \max(0, D_{ri}) + \max(0, -D_{ri})}, \quad (3.18)$$



$$H'_{Ri} = \frac{H_{Ri} + \max(0, -D_{ri}) H_j}{1 + \max(0, D_{ri}) + \max(0, -D_{ri})} \quad (3.19)$$

where  $D_{ri} = r_{Cj} - r_{Rj}$  is the difference between rents,

$$A'_i = \bar{A}_i \sum_j K_{ij} L_{wj}^\eta \quad (3.20)$$

$$L'_{Ri} = \frac{L_{Ri} + \max(0, E_{Ri}) \bar{L}}{1 + \sum_i \max(0, E_{Ri})} \quad (3.21)$$

where  $E_{Ri} = r_{Ri} H_{Ri} - (1 - \beta) y_i L_{Ri}$  is the excess supply on housing.

Second, consider  $L_{Ej}$ . Since all wages  $w_j$  may be zero, so is the  $\sum_k (w_k t_{ik})^\theta$ . Thus equation (3.11) may be ill-defined. To overcome this difficulty, we introduce an auxiliary variable  $\pi_{ij}$  satisfying for any  $i$   $\sum_j \pi_{ij} = 1$ , which is used to represent  $\frac{(w_j t_{ij})^\theta}{\sum_k (w_k t_{ik})^\theta}$  the percentage that people living in location  $i$  commute to  $j$ . We have the operator for  $L_{Ej}$  and  $\pi_{ij}$

$$L'_{Ej} = \sum_{i \in \Theta} g t_{ij} \pi_{ij}^{\frac{\theta-1}{\theta}} L_{Ri} \quad (3.22)$$

$$\pi'_{ij} = \frac{\pi_{ij} + (w_j t_{ij})^\theta}{1 + \sum_j (w_j t_{ij})^\theta} \quad (3.23)$$

where  $w_j = \pi_{wj} p A_j$ .

Third, consider  $r_{Rj}$ ,  $r_{Cj}$ , and  $w_j$ . They may potentially be zero and unbounded (non-compact). To deal with this issue, again we introduce new auxiliary variables  $\pi_{Rj}$  satisfying, which is used to represent  $\frac{r_{Ri}}{\sum_i r_{Ri}}$  location  $j$ 's relative rent price,  $\pi_{wj}$  and  $\pi_{Cj}$  satisfying for any  $j$   $\pi_{wj} + \pi_{Cj} = 1$ , which are used to present the wage and rent shares  $\frac{w_j}{p A_j}$  and  $\frac{r_{Cj}}{p A_j}$  in

location  $j$ . We have the operator for  $\pi_{Rj}$

$$\pi'_{Rj} = \frac{(u_i y_i)^{\frac{1}{1-\beta}}}{\sum_i (u_i y_i)^{\frac{1}{1-\beta}}}. \quad (3.24)$$

Notice that  $(u_i y_i)^{\frac{1}{1-\beta}}$  comes from equation (3.7) thus this equation states that when welfare is equalized, what the relative rent price should be.

We have the operator for  $\pi_{wj}$  and  $\pi_{Cj}$

$$\pi'_{Cj} = \frac{\pi_{Rj} + \max(0, E_{Lj})}{1 + \max(0, E_{Lj}) + \max(0, -E_{Lj})} \quad (3.25)$$

$$\pi'_{wj} = \frac{\pi_{wj} + \max(0, -E_{Lj})}{1 + \max(0, E_{Lj}) + \max(0, -E_{Lj})} \quad (3.26)$$

where  $E_{Lj} = L_{Ej} - H_{Cj}$  is the excess labor in location  $i$ .

We can use them to construct  $r_{Rj}$ ,  $r_{Cj}$ , and  $w_j$ . Specifically,

$$r'_{Rj} = r\pi_{Rj} \quad (3.27)$$

$$r'_{Cj} = pA_j\pi_{Cj} \quad (3.28)$$

$$w'_j = pA_j\pi_{wj} \quad (3.29)$$

where  $r = \min \left\{ \frac{(1-\beta)\bar{Y}}{\sum_i \pi_{Rj} H_{Ri}}, \bar{r} \right\}$ ,  $\bar{Y} = 1$  is the normalized total GDP and  $\bar{r} > 0$  is a large constant and will be explained shortly.

Last, we have the operator for  $y_i$ ,  $k$ , and  $p$

$$y'_i = k + g \left( \sum_k (w_k t_{ik})^\theta \right)^{\frac{1}{\theta}}, \quad (3.30)$$

$$k' = \frac{(1 - \beta) \bar{Y} + \sum r_{Cj} H_{Cj}}{\bar{L}}, \quad (3.31)$$

and

$$p' = \min \left\{ \frac{\beta \bar{Y}}{\sum_i A_j \min \{L_{Ej}, H_{Cj}\}}, \bar{p} \right\} \quad (3.32)$$

where  $\bar{p} > 0$  is also a large constant and will be explained shortly together with  $\bar{r}$ .

Let  $T : x \rightarrow x'$  be equations (3.18)-(3.32) where  $x$  (and  $x'$ ) represent all the endogenous variables (except  $U$  which can simply be calculated according to equation (3.7)) and the auxiliary variables  $\{\pi_{ij}, \pi_{Rj}, \pi_{wj}, \pi_{Cj}\}_{i,j \in \Theta}$ .  $T$  has a fixed point because all the variables can be constrained in a convex and compact domain, given  $\bar{r}$  and  $\bar{p}$ .

Each equation of fixed point of  $T$  directly implies one of market equilibrium except that in equations (3.27) and (3.32),  $r$  and  $p$  may be equal to  $\bar{r}$  and  $\bar{p}$ , which are not part of the market equilibrium. Now we show how to choose  $\bar{r}$  and  $\bar{p}$  such that for a fixed point of  $T$ ,  $r$  and  $p$  cannot be equal to  $\bar{r}$  and  $\bar{p}$ .

First, we choose a large enough  $\bar{r}$  such that  $r = \bar{r}$  must imply  $\max r_{Cj} < \max r_{Rj}$  which is against equations (3.18) and (3.19) of operator  $T$ . Assume  $r = \bar{r}$ . Notice that since  $\sum_j \pi_{Rj} = 1$ ,  $\max r_{Rj} = \max r \pi_{Rj} \geq \frac{\bar{r}}{N}$ . Since  $r = \min \left\{ \frac{(1-\beta)\bar{Y}}{\sum_i \pi_{Ri} H_{Ri}}, \bar{r} \right\}$ ,  $r = \bar{r}$  implies  $\frac{(1-\beta)\bar{Y}}{\sum_i \pi_{Ri} H_{Ri}} > \bar{r}$ . A very large  $\bar{r}$  implies that  $\sum_i H_{Ri}$  can be arbitrarily very small (in equation (3.24), a bounded  $y_i$  implies  $\pi_{Ri}$  is bounded). Therefore,  $H_{Cj}$  must be lower bounded above 0 (it has to be

approximately  $H_j$ ), so  $\sum_i A_j \min\{L_{Ej}, H_{Cj}\}$  must be lower bounded above 0 (notice that for some  $j$ ,  $L_{Ej}$  is lower bounded above 0). Therefore  $p = \min\left\{\frac{\beta\bar{Y}}{\sum_i A_j \min\{L_{Ej}, H_{Cj}\}}, \bar{p}\right\}$  is upper bounded **regardless** the value of  $\bar{p}$ . Thus  $\max r_{Cj} \leq \max p A_j$  is upper bounded. Particularly, we can choose  $\bar{r}$  large enough such that  $\max r_{Cj} < \frac{\bar{r}}{N}$ . Therefore, we have  $\max r_{Cj} < \max r_{Rj}$ .

Second, similarly, we choose a large enough  $\bar{p}$  such that  $p = \bar{p}$  must imply  $\max r_{Cj} > \max r_{Rj}$  which is against equations (3.18) and (3.19) of operator  $T$ . Assume  $p = \bar{p}$ . Therefore  $\frac{\beta\bar{Y}}{\sum_i A_j \min\{L_{Ej}, H_{Cj}\}} \geq \bar{p}$  furthermore, for any  $j$ ,  $\min\{L_{Ej}, H_{Cj}\}$  must be small enough. At the same time, for some  $j$ ,  $L_{Ej}$  is lower bounded above 0. Thus we have for some  $j$ ,  $L_{Ej} - H_{Cj}$  is lower bounded above 0. Thus  $\pi_{Cj} \geq \frac{L_{Ej} - H_{Cj}}{1 + L_{Ej} - H_{Cj}} > c$  (equation (3.25)), for some constant  $c > 0$ . At the same time,  $r_{Cj} = \pi_{Rj} p A_j$  (equation (3.28)). Thus we can choose  $\bar{p}$  high enough such that  $r_{Cj} > \bar{r}$  furthermore  $\max r_{Cj} > N\bar{r}$ . At the same time  $r_{Rj} = \pi_{Ri} r \leq \bar{r}$ . Thus we have  $\max r_{Cj} > \max r_{Rj}$ , as desired.

In all, the fixed point of  $T$  directly implies the existence of the market equilibrium.

**Part ii).** Observe that compared with part i), here the only difference is that  $\{H_{Cj}, H_{Rj}\}$  are taken as given. We can still use the same procedure as used in part i) except three simplifications. First, we do not need equations (3.18) and (3.19) anymore. Second, we only need to consider the residential rents in locations  $i$  where  $H_{Ri} > 0$  and productions in location  $j$  where  $H_{Cj} > 0$ . Third, denote the sets of the two type locations as  $\Theta_R$  and  $\Theta_C$ . Simply set  $r = \frac{(1-\beta)\bar{Y}}{\sum_{i \in \Theta_R} \pi_{Rj} H_{Ri}}$  and  $p' = \frac{\beta\bar{Y}}{\sum_{j \in \Theta_C} A_j \min\{L_{Ej}, H_{Cj}\}}$ , which are naturally upper bounded. That is we do not have to construct auxiliary variables  $\bar{r}$  and  $\bar{p}$  anymore. ■

### 3.5.3 Proof of Proposition 2

*Proof.* Since  $\eta = 0$ , we can treat the productivity as exogenous. It is sufficient to show the market equilibrium is equivalent with the social planner's problem. We proceed by showing the first order conditions of the social planner are equivalent with the market equilibrium conditions. Toward this end, we first transform the social planner problem into a more tractable form.

Observe that it is without loss generality to require  $\frac{q_i}{h_i} = \frac{q_{ij}}{h_{ij}}$ ; otherwise, different agents commute from  $i$  to  $j$  have different Marginal Rate of Substitution therefore there is room to improve agents' welfare (without changing agents locational choices). Thus, we assume one  $q_i = c_i a_i$ ,  $h_i = c_i b_i$ ,  $q_{ij} = c_{ij} a_i$ , and  $h_{ij} = c_{ij} b_i$  where  $c_i, c_{ij} \geq 0$  and  $a_i, b_i > 0$  satisfy

$$a_i^\beta b_i^{1-\beta} = 1 \quad (3.33)$$

which represents one unit consumption bundle at location  $i$ . Thus given agent's choice of where to live, they just need to solve  $\max_{j \in \Theta} a_j(\omega) c_{ij} t_{ij}$ . Notice that this is the same problem as in the market equilibrium  $\max_{j \in \Theta} w_j a_j(\omega) t_{ij}$  except that we replace  $w_j$  with  $c_{ij}$ .

Thus by defining

$$W_i^\theta = \sum_j (t_{ij} c_{ij})^\theta, \quad (3.34)$$

similarly as we do for the market equilibrium, we obtain agents' average consumption and productivity in location  $i$  are  $c_i + g W_i$  and  $g \frac{(c_{ij} t_{ij})^{\theta-1}}{W_i^{\theta-1}}$  (recall  $g$  is defined as  $\Gamma\left(\frac{\theta-1}{\theta}\right)$ ).

Therefore, we have: the total consumed goods constraint

$$\sum_i a_i (c_i + gW_i) L_{Ri} \leq \sum_j A_j \min (L_{Ej}, H_{Cj}), \quad (3.35)$$

the residential building at location  $i$

$$b_i (c_i + gW_i) L_{Ri} \leq H_{Ri},$$

and the constraint of the total effective labor at location  $j$

$$L_{Ej} \leq \sum_{i \in \Theta} t_{ij} g \frac{(c_{ij} t_{ij})^{\theta-1}}{W_i^{\theta-1}} L_{Ri}. \quad (3.36)$$

In addition, we have the welfare equalization condition

$$U = u_i (c_i + gW_i). \quad (3.37)$$

Therefore, the social planner's problem becomes

$$\max_{\{U, c_i, c_{ij}, W_i, a_i, b_i, H_{Ri}, H_{Cj}, L_{Ri}, L_{Ej}\}_{i,j \in \Theta}} U$$

subject to equations 3.33-3.37 and equations (3.6) and (3.16).

Set up the Lagrange function

$$\begin{aligned}
\mathcal{L} = & U + \sum_i \lambda_{Ei} \left( q_i^\beta h_i^{1-\beta} - 1 \right) + \sum_i \lambda_{Wi} \left( W_i^\theta - \sum_j (t_{ij} c_{ij})^\theta \right) + \sum_i \lambda_{ri} (H_i - H_{Ri} - H_{Ci}) \\
& + \lambda_p \left( \sum_j A_j \min(L_{Ej}, H_{Cj}) - \sum_i a_i (c_i + gW_i) L_{Ri} \right) + \sum_i \lambda_{rRi} (H_{Ri} - b_i (c_i + gW_i) L_{Ri}) \\
& + \lambda_k \left( \bar{L} - \sum_i L_{Ri} \right) + \sum_j \lambda_{wj} \left( \sum_i t_{ij} g \frac{(c_{ij} t_{ij})^{\theta-1}}{W_i^{\theta-1}} L_{Ri} - L_{Ej} \right) + \sum_i \lambda_{Pi} (u_i (c_i + gW_i) - U)
\end{aligned}$$

where  $\{\lambda_{Ei}, \lambda_{Wi}, \lambda_{ri}, \lambda_p, \lambda_{rRi}, \lambda_k, \lambda_{wj}, \lambda_{Pi}\}_{i,j \in \Theta}$  are the constraints' corresponding Lagrange multipliers.

Now we consider this Lagrange function's first order conditions. Differentiate it with respect to the Lagrange multipliers, we get the above constraints thus we do not reprint them; differentiate it with respect to  $\{U, c_i, c_{ij}, W_i, a_i, b_i, H_{Ri}, H_{Cj}, L_{Ri}, L_{Ej}\}_{i,j \in \Theta}$ , we get <sup>2</sup>

$$\frac{\partial \mathcal{L}}{\partial U} = 1 - \sum_i \lambda_{Pi} = 0, \quad (3.38)$$

$$\frac{\partial \mathcal{L}}{\partial c_i} = -\lambda_p a_i L_{Ri} - \lambda_{rRi} b_i L_{Ri} - \lambda_{Pi} u_i = 0, \quad (3.39)$$

$$\frac{\partial \mathcal{L}}{\partial c_{ij}} = -\lambda_{Wi} \theta \frac{(t_{ij} c_{ij})^\theta}{c_{ij}} + \lambda_{wj} t_{ij} g (\theta - 1) \frac{(c_{ij} t_{ij})^{\theta-1}}{c_{ij} W_i^{\theta-1}} L_{Ri} = 0, \quad (3.40)$$

$$\frac{\partial \mathcal{L}}{\partial W_i} = \lambda_{Wi} \theta \frac{W_i^\theta}{W_i} - \lambda_p a_i g L_{Ri} - \lambda_{rRi} b_i g L_{Ri} + \sum_j \lambda_{wj} t_{ij} g (1 - \theta) \frac{(c_{ij} t_{ij})^{\theta-1}}{W_i^{\theta-1} W_i} - \lambda_{Pi} u_i g = 0, \quad (3.41)$$

$$\frac{\partial \mathcal{L}}{\partial a_i} = \lambda_{Ei} \beta a_i^{\beta-1} b_i^{1-\beta} - \lambda_p (c_i + gW_i) L_{Ri} = 0, \quad (3.42)$$

---

2. Here, we do not consider the corner case here. For the corner case, the same procedure follows except that we need to use the complementary-slackness form.

$$\frac{\partial \mathcal{L}}{\partial b_i} = \lambda_{Ei} (\beta - 1) a_i^\beta b_i^{-\beta} - \lambda_{rRi} (c_i + gW_i) L_{Ri} = 0, \quad (3.43)$$

$$\frac{\partial \mathcal{L}}{\partial H_{Ri}} = \lambda_{rRi} - \lambda_{ri} = 0, \quad (3.44)$$

$$\frac{\partial \mathcal{L}}{\partial H_{Ci}} = \lambda_p A_j x - \lambda_{ri} = 0, \quad (3.45)$$

$$\frac{\partial \mathcal{L}}{\partial L_{Ri}} = -\lambda_p a_i (c_i + gW_i) - \lambda_{rRi} b_i (c_i + gW_i) - \lambda_k + \sum_j \lambda_{wj} t_{ij} g \frac{(c_{ij} t_{ij})^{\theta-1}}{W_i^{\theta-1}} = 0, \quad (3.46)$$

and

$$\frac{\partial \mathcal{L}}{\partial L_{Ej}} = \lambda_p A_j y - \lambda_{wj} = 0 \quad (3.47)$$

where  $x, y \in [0, 1]$  are used to represent the subgradients of  $\min(L_{Ej}, H_{Cj})$  with respect to  $L_{Ej}$  and  $H_{Cj}$ .

In below, we show that the market equilibrium result satisfies the first order conditions of the social planner problem. If we substitute the corresponding  $\{U, c_i, c_{ij}, W_i, a_i, b_i, H_{Ri}, H_{Cj}, L_{Ri}, L_{Ej}\}_{i,j \in \Theta}$  of the market equilibrium result, clearly equations 3.33-3.37 and equations (3.6) and (3.16) are satisfied. Thus we just need to check if we can find corresponding Lagrange multipliers such that equations 3.38-3.47 hold.

We first construct the Lagrange multipliers with the help of use the market results. Set  $\lambda_p = p$  the price of goods;  $\lambda_{wj} = w_j$  the wage per efficient unit;  $\lambda_{ri} = \lambda_{rRi} = r_{Ri}$  the residential rent<sup>3</sup>;  $\lambda_k = k$  capital income;  $\lambda_{Pi} = \beta^\beta (1 - \beta)^{1-\beta} p^\beta r_{Ri}^{1-\beta} \frac{L_{Ri}}{u_i}$ ;  $\lambda_{Wi} = \lambda_{wj} \frac{\theta-1}{\theta} \frac{1}{c_{ij} W_i^{\theta-1}} L_{Ri}$ ;  $\lambda_{Ei} = y_i L_{Ri}$  the total expenditure. Now we verify equations 3.38-3.47 one by one. Equation 3.38 holds by setting the right nominal price  $p$ ; Equation 3.39 because it is exactly the budget constraint for people who consumes one unit consumption bundle;

---

3. Again, here we only consider the non-corner case; for the corner case, the first order conditions are in the complementary-slackness form.



Equation 3.40 clearly holds after substituting  $\lambda_{W_i} = \lambda_{w_j} \frac{\theta-1}{\theta} \frac{1}{c_{ij} W_i^{\theta-1}} L_{Ri}$ ; Equation 3.41 holds because it is a linear summation of equations 3.39 and 3.40; Equations 3.42 and 3.43 holds because they are exactly the expenditure spent on goods and housing; Equations 3.42 and 3.43 holds because they are the rent equalization conditions; Equation 3.46 is the budget constraint for an average consumer satisfied; Equation 3.47 is simply the wage equation.

Also, any solution of the social planner corresponds to a market equilibrium. Notice that we can reversely use the same equations and Lagrange multipliers in the above paragraph to construct the market results. ■

# Bibliography

- D. Acemoglu, V. M. Carvalho, A. Ozdaglar, and A. Tahbaz-Salehi. The network origins of aggregate fluctuations. *Econometrica*, 80(5):1977–2016, 2012.
- G. M. Ahlfeldt, S. J. Redding, D. M. Sturm, and N. Wolf. The economics of density: Evidence from the berlin wall. *CEPR Working paper*, 1154, 2012.
- G. M. Ahlfeldt, S. J. Redding, D. M. Sturm, and N. Wolf. The economics of density: Evidence from the berlin wall. *Econometrica*, 83(6):2127–2189, 2015.
- T. Allen and C. Arkolakis. Trade and the topography of the spatial economy. *Quarterly Journal of Economics*, 2014.
- T. Allen and D. Donaldson. The geography of path dependence. *Unpublished manuscript*, 2018.
- T. Allen, C. Arkolakis, and Y. Takahashi. Universal gravity. *mimeo*, 2014.
- W. Alonso et al. Location and land use. toward a general theory of land rent. *Location and land use. Toward a general theory of land rent.*, 1964.

- F. Alvarez and R. E. Lucas. General equilibrium analysis of the eaton-kortum model of international trade. *Journal of Monetary Economics*, 54(6):1726–1768, 2007.
- A. Anas and I. Kim. General equilibrium models of polycentric urban land use with endogenous congestion and job agglomeration. *Journal of Urban Economics*, 40:232–256, 1996.
- A. Anas and H.-J. Rhee. Curbing excess sprawl with congestion tolls and urban boundaries. *Regional Science and Urban Economics*, 36:510–541, 2006.
- N. Anbarci and J. P. Bigelow. The area monotonic solution to the cooperative bargaining problem. *Mathematical Social Sciences*, 28(2):133–142, 1994.
- N. Anbarci and C.-j. Sun. Robustness of intermediate agreements and bargaining solutions. *Games and Economic Behavior*, 77(1):367–376, 2013.
- C. Arkolakis, A. Costinot, and A. Rodríguez-Clare. New trade models, same old gains? *American Economic Review*, 102(1):94–130, 2012.
- K. J. Arrow, F. Hahn, et al. General competitive analysis. 1971.
- D. R. Baqaee and E. Farhi. Macroeconomics with heterogeneous agents and input-output networks. Technical report, National Bureau of Economic Research, 2018.
- S. Berry, A. Gandhi, and P. Haile. Connected substitutes and invertibility of demand. *Econometrica*, 81(5):2087–2111, 2013.
- K. Binmore. Bargaining conventions. *International Journal of Game Theory*, 13(4):193–200, 1984.

- K. Binmore, A. Rubinstein, and A. Wolinsky. The nash bargaining solution in economic modelling. *The RAND Journal of Economics*, pages 176–188, 1986.
- W. A. Brock and S. N. Durlauf. Discrete choice with social interactions. *The Review of Economic Studies*, 68(2):235–260, 2001.
- L. Calmfors and J. Driffill. Bargaining structure, corporatism and macroeconomic performance. *Economic policy*, 3(6):13–61, 1988.
- V. M. Carvalho and A. Tahbaz-Salehi. Production networks: A primer. *Annual Review of Economics*, 11:635–663, 2019.
- V. M. Carvalho, M. Nirei, Y. Saito, and A. Tahbaz-Salehi. Supply chain disruptions: Evidence from the great east japan earthquake. *forthcoming, Quarterly Journal of Economics*, 2019.
- T. Chaney. Distorted gravity: The intensive and extensive margins of international trade. *American Economic Review*, 98(4):1707–1721, 2008.
- P.-A. Chiappori. Collective labor supply and welfare. *Journal of political Economy*, 100(3):437–467, 1992.
- Y. Chun. Nash solution and timing of bargaining. *Economics Letters*, 28(1):27–31, 1988.
- A. Costinot and A. Rodriguez-Clare. Trade theory with numbers: Quantifying the consequences of globalization. Technical report, National Bureau of Economic Research, 2013.
- E. Dekel. untitled. Technical report, Harvard University, 1982.

- J. Eaton and S. Kortum. Technology, geography and trade. *Econometrica*, 70(5):1741–1779, 2002.
- F. Y. Edgeworth. *Mathematical psychics: An essay on the application of mathematics to the moral sciences*, volume 10. Kegan Paul, 1881.
- M. Elliott and B. Golub. A network approach to public goods. *Journal of Political Economy*, 127(2):730–776, 2019.
- J. Fernández-Villaverde, J. F. Rubio-Ramírez, and F. Schorfheide. Solution and estimation methods for dsge models. In *Handbook of macroeconomics*, volume 2, pages 527–724. Elsevier, 2016.
- B. Fine and G. Rosenberger. *The Fundamental Theorem of Algebra*. Springer Science & Business Media, 1997.
- M. Fujita and H. Ogawa. Multiple equilibria and structural transition of non-monocentric urban configurations. *Regional science and urban economics*, 12(2):161–196, 1982.
- M. Fujita and J.-F. Thisse. *Economics of agglomeration: cities, industrial location, and globalization*. Cambridge university press, 2013.
- D. Gale and H. Nikaido. The jacobian matrix and global univalence of mappings. *Mathematische Annalen*, 159(2):81–93, 1965.
- E. Glaeser and J. Scheinkman. Non-market interactions. In M. Armstrong and R. Porter, editors, *In Advances in Economics and Econometetrics: Theory and Applications, Eighth World Congress*. Cambridge, UK: Cambridge University Press, 2002.

- E. L. Glaeser and J. D. Gottlieb. The economics of place-making policies. *Brooking Papers of Economics Activity*, 2008.
- E. L. Glaeser, B. I. Sacerdote, and J. A. Scheinkman. The social multiplier. *Journal of the European Economic Association*, 1(2-3):345–353, 2003.
- G. M. Grossman and E. Helpman. *Special interest politics*. MIT press, 2001.
- S. J. Grossman and O. D. Hart. The costs and benefits of ownership: A theory of vertical and lateral integration. *Journal of political economy*, 94(4):691–719, 1986.
- J. C. Harsanyi. Approaches to the bargaining problem before and after the theory of games: a critical discussion of zeuthen’s, hicks’, and nash’s theories. *Econometrica, Journal of the Econometric Society*, pages 144–157, 1956.
- O. Hart. *Firms, contracts, and financial structure*. Clarendon press, 1995.
- D. Hawkins and H. A. Simon. Note: some conditions of macroeconomic stability. *Econometrica, Journal of the Econometric Society*, pages 245–248, 1949.
- J. V. Howard. A social choice rule and its implementation in perfect equilibrium. *Journal of Economic Theory*, 56(1):142–159, 1992.
- Y. M. Ioannides. *From Neighborhoods to Nations: The Economics of Social Interactions*. Princeton University Press, 2013.
- J. Iritani. On uniqueness of general equilibrium. *The Review of Economic Studies*, 48(1): 167–171, 1981.

- E. Kalai and M. Smorodinsky. Other solutions to nash's bargaining problem. *Econometrica: Journal of the Econometric Society*, pages 513–518, 1975.
- T. J. Kehoe. Multiplicity of equilibria and comparative statics. *The Quarterly Journal of Economics*, pages 119–147, 1985.
- T. J. Kehoe, J. Whalley, et al. Uniqueness of equilibrium in large-scale numerical general equilibrium models. *Journal of Public Economics*, 28(2):247–254, 1985.
- J. Kennan. Uniqueness of positive fixed points for increasing concave functions on  $\mathbb{R}^n$ : An elementary result. *Review of Economic Dynamics*, 4(4):893–899, 2001.
- T. Lensberg. Stability and the nash solution. *Journal of Economic Theory*, 45(2):330–341, 1988.
- Z. A. Livne. Axiomatic characterizations of the raiffa and the kalai-smorodinsky solutions to the bargaining problem. *Operations research*, 37(6):972–980, 1989.
- R. Lucas and N. L. Stokey. *Recursive methods in economic dynamics*. Harvard University Press, 1989.
- R. E. Lucas and E. Rossi-Hansberg. On the internal structure of cities. *Econometrica*, 70(4):1445–1476, 2003.
- R. D. Luce and H. Raiffa. *Games and decisions: Introduction and critical survey*. John Wiley & Sons, Inc., 1965.
- M. Manser and M. Brown. Marriage and household decision-making: A bargaining analysis. *International economic review*, pages 31–44, 1980.

- A. Mas-Colell, M. D. Whinston, and J. R. Green. *Microeconomic Theory*. Oxford University Press, Oxford, UK, 1995.
- M. Maschler, G. Owen, and B. Peleg. Paths leading to the nash set. *The Shapley Value, Essays in Honor of Lloyd Shapley*, pages 321–330, 1988.
- M. B. McElroy and M. J. Horney. Nash-bargained household decisions: Toward a generalization of the theory of demand. *International economic review*, pages 333–349, 1981.
- C. D. Meyer. *Matrix analysis and applied linear algebra*. Siam, 2000.
- E. S. Mills. An aggregative model of resource allocation in a metropolitan area. *The American Economic Review*, pages 197–210, 1967.
- F. Monte, S. J. Redding, and E. Rossi-Hansberg. Commuting, migration, and local employment elasticities. *American Economic Review*, 108(12):3855–90, 2018.
- H. Moulin. Le choix social utilitarist. Technical report, Ecole Polytechnique Discussion Paper, 1983.
- R. Muth. Cities and housing: The spatial patterns of urban residential land use. *University of Chicago, Chicago*, 1969.
- J. Nash. The bargaining problem. *Econometrica: Journal of the Econometric Society*, pages 155–162, 1950.
- P. J. Olver. Numerical analysis lecture notes. *mimeo*, 2008.



- M. A. Perles and M. Maschler. The super-additive solution for the nash bargaining game. *International Journal of Game Theory*, 10(3-4):163–193, 1981.
- H. Peters and E. Van Damme. Characterizing the nash and raiffa bargaining solutions by disagreement point axioms. *Mathematics of Operations Research*, 16(3):447–461, 1991.
- H. J. Peters. *Axiomatic bargaining game theory*, volume 9. Springer Science & Business Media, 1992.
- C. A. Pissarides. *Equilibrium unemployment theory*. MIT press, 2000.
- H. Raiffa. Arbitration schemes for generalized two-person games. *Annals of Mathematics Studies*, 28:361–387, 1953.
- S. J. Redding. Goods trade, factor mobility and welfare. *Journal of International Economics*, 101:148–167, 2016.
- S. J. Redding and E. A. Rossi-Hansberg. Quantitative spatial economics. *Annual Review of Economics*, 9(1), 2017.
- Z. Ritz. An equal sacrifice solution to nash’s bargaining problem. *BEER faculty working paper; no. 1147*, 1985.
- E. Rossi-Hansberg. A spatial theory of trade. *American Economic Review*, 95(5):1464–1491, 2005.
- A. E. Roth. *Axiomatic models of bargaining*, volume 170. Springer-Verlag Berlin Heidelberg, 1979.

- A. Rubinstein, Z. Safra, and W. Thomson. On the interpretation of the nash bargaining solution and its extension to non-expected utility preferences. *Econometrica: Journal of the Econometric Society*, pages 1171–1186, 1992.
- L. S. Shapley. Utility comparison and the theory of games. *The Shapley Value, Essays in Honor of Lloyd Shapley*, pages 307–320, 1988.
- A. Shleifer and R. W. Vishny. Politicians and firms. *The quarterly journal of economics*, 109(4):995–1025, 1994.
- J. Sobel. Distortion of utilities and the bargaining problem. *Econometrica: Journal of the Econometric Society*, pages 597–619, 1981.
- M. Spence. Job market signaling. In *Uncertainty in economics*, pages 281–306. Elsevier, 1978.
- W. Thomson. Cooperative models of bargaining. *Handbook of game theory with economic applications*, 2:1237–1284, 1994.
- J. Tirole. *The theory of industrial organization*. MIT press, 1988.
- W. Trockel. A universal meta bargaining implementation of the nash solution. *Social Choice and Welfare*, 19:581–586, 2002.
- M. A. Turner, A. Haughwout, and W. van der Klaauw. Land use regulation and welfare. *Econometrica*, 82(4):1341–1403, 2014.
- E. Van Damme. The nash bargaining solution is optimal. *Journal of Economic Theory*, 38(1):78–100, 1986.

E. Van Damme. Stable equilibria and forward induction. *Journal of Economic Theory*, 48 (2):476–496, 1989.

F. Zeuthen. *Problems of monopoly and economic warfare*.

ProQuest Number: 28321897

INFORMATION TO ALL USERS

The quality and completeness of this reproduction is dependent on the quality and completeness of the copy made available to ProQuest.



Distributed by ProQuest LLC (2021).

Copyright of the Dissertation is held by the Author unless otherwise noted.

This work may be used in accordance with the terms of the Creative Commons license or other rights statement, as indicated in the copyright statement or in the metadata associated with this work. Unless otherwise specified in the copyright statement or the metadata, all rights are reserved by the copyright holder.

This work is protected against unauthorized copying under Title 17, United States Code and other applicable copyright laws.

Microform Edition where available © ProQuest LLC. No reproduction or digitization of the Microform Edition is authorized without permission of ProQuest LLC.

ProQuest LLC  
789 East Eisenhower Parkway  
P.O. Box 1346  
Ann Arbor, MI 48106 - 1346 USA