

1994

## Development and Application of a Thermistor Current Meter

Carl M. Way

Albert J. Burky

Christine Miller-Way

Follow this and additional works at: [https://ecommons.udayton.edu/bio\\_fac\\_pub](https://ecommons.udayton.edu/bio_fac_pub)

 Part of the [Biology Commons](#), [Biotechnology Commons](#), [Cell Biology Commons](#), [Genetics Commons](#), [Microbiology Commons](#), and the [Molecular Genetics Commons](#)

---

\*Original contains color plates. All DTIC reproductions will be in black and white\*

Technical Report EL-94-1  
January 1994



**US Army Corps  
of Engineers**  
Waterways Experiment  
Station

**DTIC**  
ELECTE  
FEB 18 1994  
**AD-A275 816**

# Development and Application of a Thermistor Current Meter

by *Carl M. Way*  
*Environmental Laboratory*

*Albert J. Burky*  
*University of Dayton*

*Christine A. Miller-Way*  
*Louisiana State University*



Approved For Public Release; Distribution Is Unlimited

DTIC QUALITY INSPECTED 3

411388  
**94-05335**

94 2 17 057

Prepared for U.S. Army Engineer District, Honolulu  
and U.S. Environmental Protection Agency

# DISCLAIMER NOTICE

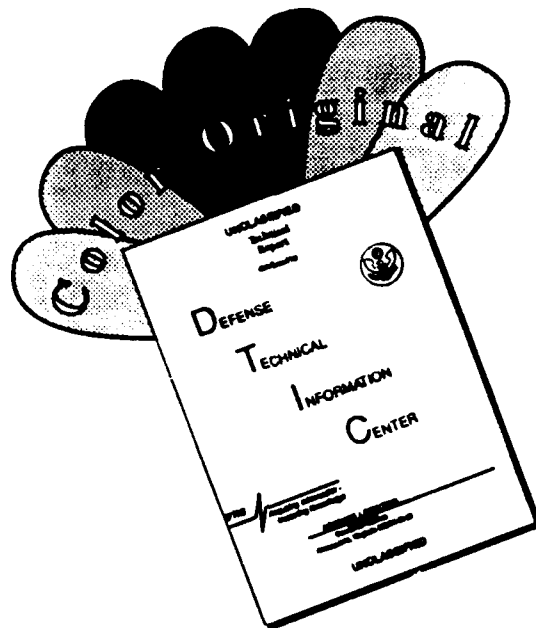

**THIS DOCUMENT IS BEST QUALITY AVAILABLE. THE COPY FURNISHED TO DTIC CONTAINED A SIGNIFICANT NUMBER OF COLOR PAGES WHICH DO NOT REPRODUCE LEGIBLY ON BLACK AND WHITE MICROFICHE.**

# Development and Application of a Thermistor Current Meter

by Carl M. Way  
Environmental Laboratory  
U.S. Army Corps of Engineers  
Waterways Experiment Station  
3909 Halls Ferry Road  
Vicksburg, MS 39180-6199

Albert J. Burky  
Department of Biology  
University of Dayton  
Dayton, OH 45469

Christine A. Miller-Way  
Department of Ocean Sciences  
Louisiana State University  
Baton Rouge, LA 70803

Final report

Approved for public release; distribution is unlimited

Accession For	
NTIS CRA&I	<input checked="" type="checkbox"/>
DTIC TAB	<input checked="" type="checkbox"/>
Unannounced	<input checked="" type="checkbox"/>
Justification _____	
By _____	
Distribution /	
Availability Codes	
Dist	Avail and/or Special
A-1	

Prepared for U.S. Army Engineer District, Honolulu  
Fort Shafter, HI 96858  
and U.S. Environmental Protection Agency, Region IX  
San Francisco, CA 94105



**US Army Corps  
of Engineers**  
Waterways Experiment  
Station

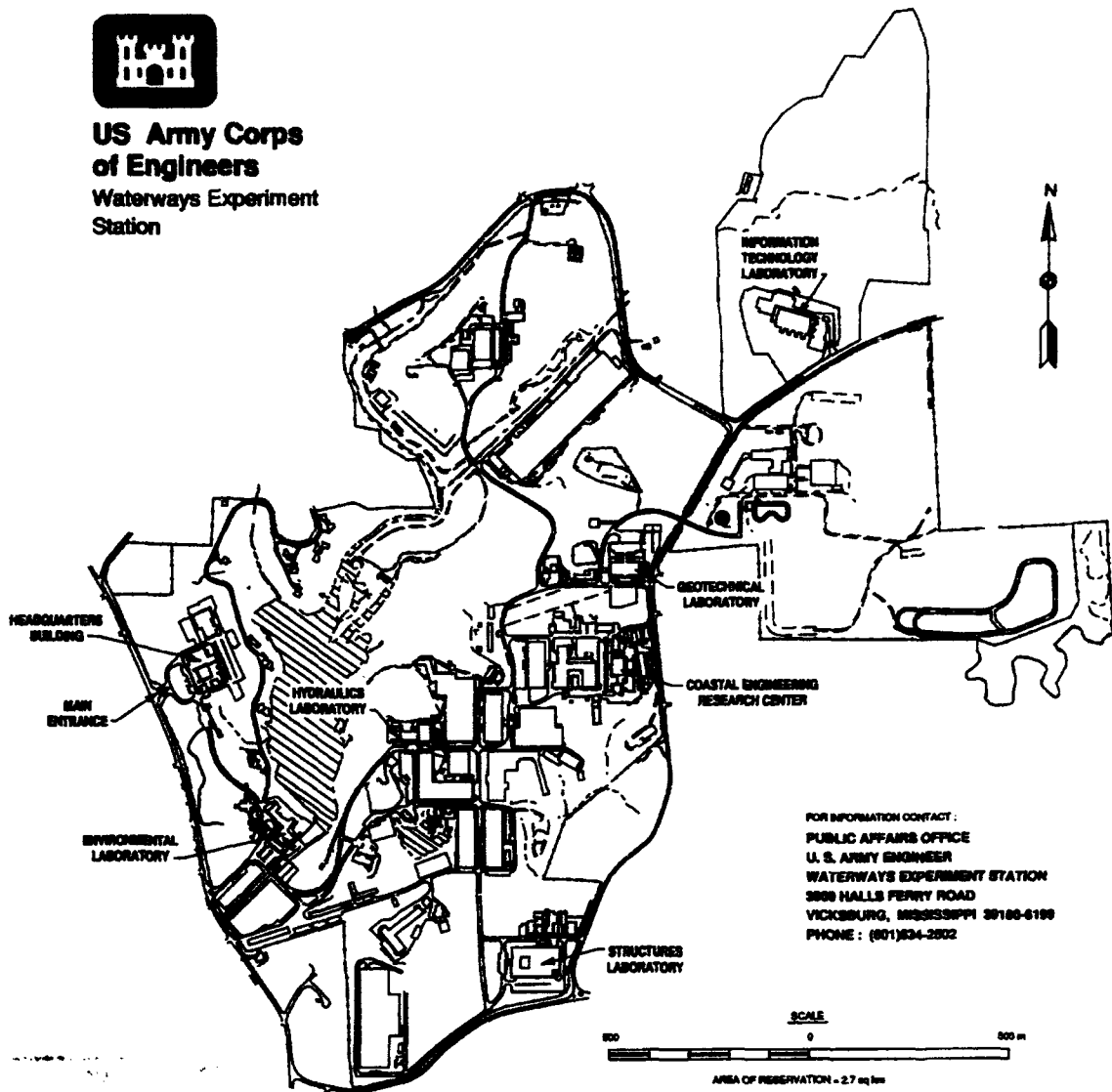

**Waterways Experiment Station Cataloging-in-Publication Data**

Way, Carl M.

Development and application of a thermistor current meter / by Carl M. Way; Albert J. Burky Christine A. Miller-Way ; prepared for U.S. Army Engineer District, Honolulu and U.S. Environmental Protection Agency, Region IX.

33 p. : ill. ; 28 cm. -- (Technical report ; EL-94-1)

Includes bibliographical references.

1. Fish screens -- Evaluation. 2. Dams -- Columbia River -- Environmental aspects. 3. Underwater imaging systems. 4. Fishes -- Migration. I. Burky, Albert J. II. Miller-Way, Christine A. III. United States. Army. Corps of Engineers. Honolulu District. IV. United States. Environmental Protection Agency. Region IX. V. U.S. Army Engineer Waterways Experiment Station. VI. Title. VII. Series: Technical report (U.S. Army Engineer Waterways Experiment Station) ; EL-94-1.

TA7 W34 no.EL-94-1

# Contents

---

Preface . . . . .	iv
Conversion Factors, Non-SI to SI Units of Measurement . . . . .	v
1—Introduction . . . . .	1
Background . . . . .	1
Purpose and Scope . . . . .	2
2—Construction of Thermistor Probe and Calibration System . . . . .	3
Thermistor Probe . . . . .	3
Calibration System . . . . .	5
Power Sources and Data Collection . . . . .	7
Field and Laboratory Examples . . . . .	8
Conclusions . . . . .	10
References . . . . .	11
Figures 1-14	
SF 298	

# Preface

---

In October 1990, the U.S. Army Engineer Waterways Experiment Station (WES) initiated the development of a thermistor-based current meter for use in determining the microhabitat requirements of organisms in Hawaiian streams. The purpose was to investigate the impacts of water diversion projects on the habitat of endemic stream organisms.

This study was funded by the Operations Division, Honolulu District, Pacific Ocean Division, Fort Shafter, Hawaii, with assistance from the U.S. Environmental Protection Agency, Region IX, San Francisco, California.

This report was prepared by Drs. Carl M. Way, Environmental Laboratory (EL), Albert J. Burky, University of Dayton, and Christine A. Miller-Way, Louisiana State University. The authors would like to thank those who provided field assistance: Mr. Skippy Hau (Department of Aquatic Resources, Maui), Dr. Bob Nishimoto (Department of Aquatic Resources, Hawaii), and Mr. Daryl Kuamoo (Department of Aquatic Resources, Hawaii). The authors would also like to thank Mr. Bill Devick of the State of Hawaii Department of Aquatic Resources for his cooperation and support of this project.

The report was prepared under the general supervision of Dr. Edwin Theriot, Chief, Aquatic Ecology Branch, EL, Dr. Conrad J. Kirby, Chief, Ecological Research Division, EL, and Dr. John Harrison, Director, EL. The technical monitor for this study was Mr. Mike Lee, Pacific Ocean Division.

At the time of publication of this report, Director of WES was Dr. Robert W. Whalin. Commander was COL Bruce K. Howard, EN.

This report should be cited as follows:

Way, C. M., Burky, A. J., and Miller-Way, C. A. (1994). "Development and application of a thermistor current meter," Technical Report EL-94-1, U.S. Army Engineer Waterways Experiment Station, Vicksburg, MS.

# Conversion Factors, Non-SI to SI Units of Measurement

---

Non-SI units of measurement used in this report can be converted to SI units as follows:

<b>Multiply</b>	<b>By</b>	<b>To Obtain</b>
cubic feet	0.0283	cubic meters
feet	0.3048	meters
inches	2.54	centimeters



# 1 Introduction

---

## Background

Habitat utilization is an important criterion for understanding the limits to the distribution and abundance of aquatic organisms. One variable which has an impact on aquatic organisms is the distribution and magnitude of water turnover and velocity. Traditionally, various measures of water-column velocity have been used to predict the habitat preferences of benthic organisms. Such measurements often do not provide an accurate description of the flow regime encountered by benthic organisms in streams with considerable substrate heterogeneity and shallow-water depths. Water-column flows did not predict conditions of benthic microhabitats based on measurements taken with a hot-bead thermistor flowmeter in high-gradient/high-substrate-heterogeneity Hawaiian rainforest streams (Burky et al. 1990, Way and Burky 1992a, Way, Burky, and Lee 1993) and in a low-gradient/low-substrate-heterogeneity mainland river (Harding and Burky 1993, Harding et al. 1992, Frenia et al. 1992, Trail et al. 1992). The importance of water movement on the biology of aquatic organisms has been shown to be influenced by shape (Burky, Way, and Lee 1991; Denny 1988, 1989; Statzner 1988; Statzner and Holm 1989; Vogel 1988; Way et al., in preparation; Weisenberger et al. 1991), behavior (Chance and Craig 1986, Way and Burky 1993), life cycle (Way et al., in preparation, Way and Burky 1993), season (Way and Burky 1992b; Way, Burky, and Lee 1991), and physical habitat (Barmuta 1990; Burky et al. 1990; Davis and Barmuta 1989; Denny 1988; Murvosh 1991; Statzner and Higler 1986; Statzner, Resh, and Gore 1988; Way, Burky, and Lee 1991; Way, Burky, and Lee 1993).

The flowing environment can range from nearly still water in lentic environments, velocity shelters of lotic habitats, slow velocities of swamps, fens, and marshes, to high-velocity waters of mountain streams or large rivers. The interaction of water velocity with substrate heterogeneity can provide velocity shelters in high discharge streams where water movement can be defined as turbulent and/or torrential. These velocity shelters can be visually transparent and unrelated to water-column velocity (Burky et al. 1990; Harding and Burky 1993; Way and Burky 1992a; Way, Burky, and Lee, in preparation). Hence, an organism can be positioned in an

apparent "open" habitat exposed to turbulent and/or torrential flow but actually be in a low-velocity shelter. Predictions of benthic velocities from water-column velocity measurements fail to address the spatial variability of velocities adjacent to substrates where benthic organisms live. Unlike bulky mechanical or electromagnetic flowmeters with relatively poor spatial resolution, hot-bead thermistor current meters are small, inexpensive, have a spatial resolution on the order of millimeters, and are adaptable to many field and laboratory applications. Hot-bead current meters have been used for collecting data representing a range from low velocities in lentic systems (Lossee and Wetzel 1988, MacIntyre 1986) to high velocities in temperate (Harding and Burky 1993) and torrential (Way and Burky 1993) stream habitats.

## **Purpose and Scope**

This report provides details for the construction of a hot-bead thermistor current meter, which is capable of measuring water velocities on a millimeter spatial scale, and for the construction of a compact and accurate calibration system. Examples of field and laboratory applications are also provided.

## 2 Construction of Thermistor Probe and Calibration System

---

### Thermistor Probe

The electrical components of the hot-bead thermistor current meter were assembled according to the description of LaBarbera and Vogel (1976) with subsequent corrections, modifications, and simplifications provided by Vogel (1981). Hot-bead thermistor current meters can be built with response times of 200 ms capable of measuring velocities between 0.1 and 80 cm s<sup>-1</sup>; velocities  $\geq 1.0$  m s<sup>-1</sup> can be measured by changing resistor configuration. The sensing thermistor ( $T_s$ ) is held at a constant 10 °C above ambient regardless of water temperature or movement. The resulting potential difference across the bridge between  $T_s$  and the compensating thermistor ( $T_c$ ) is approximately proportional to the logarithm of water velocity. Therefore, accuracy is best at low velocities and more variable at high values. The thermistor current meter does not measure velocity vectors. Velocity data from a stream or experimental flume is a measure of the sum of all vectors. Therefore, accurate calibration in laminar flow is crucial (Figures 1 and 3). Calibration at two levels of flow is achieved by varying resistors in the circuitry (LaBarbera and Vogel 1976, Vogel 1981) while  $T_s$  is under conditions of controlled laminar flow.

The construction of a sturdy probe for application in lotic systems such as high-gradient Hawaiian streams was achieved by modifying the design of LaBarbera and Vogel (1976) through the use of heavy-duty acrylic tubing, small stainless steel gas-chromatography tubing, and flexible Tygon spaghetti tubing (Figures 1c and 5). An acrylic handle anchors (using epoxy and silicone aquarium cement) the electrical cable at one end and  $T_s$  and  $T_c$  at the other; small spatial flow resolution ( $\leq 2$  mm) is maintained at the end of durable stainless steel tubing with  $T_s$  heat fused in the Tygon tubing.

Construction of a probe requires concentration, patience, and dexterity. Once all the materials (Figure 5) have been procured, the acrylic and stainless steel tubing are cut to desired length with ends sanded to remove burrs. The two pieces of acrylic tube are fused to each other with dichlorethane or other appropriate solvent. A third piece of large acrylic tube can be cut and set aside for use as a probe protector (Figures 7d and 7e). Leads from  $T_s$  and  $T_c$  (from Victory Engineering Corporation, Springfield, NJ) must be short with tight junction bends. The  $T_s$  and  $T_c$  (Figure 5) are held in clamps and soldered (no excess solder), using a gas-fired soldering iron, to tiny coated wires under a dissecting microscope. Insulation from larger gauge wire is slipped over the bare wire to prevent shorting. The Tygon spaghetti tubing is slipped over the stainless steel tube so that it overlaps at one end. The wires from  $T_s$  are then threaded (with a stiffener wire if needed to prevent excess bending of the tip for a particular application) through the Tygon and stainless steel tubing; patience is necessary for this tight fit process in order to maintain the integrity of the soldered assembly. Mounting of  $T_c$  varies depending on the application. The easiest construction for many field applications is to simply embed  $T_c$  with its tip exposed (no Tygon tubing) in the silicone potting cement (Figure 7e) at the base of the rod for  $T_s$ . Another method is to thread  $T_c$  through Tygon tubing with a stiffener wire (no stainless steel tubing, Figure 5), so it can be bent to a needed position.  $T_s$  and  $T_c$  must both be submerged for the flowmeter to work. That is, the shallower the water the longer the extension needed for  $T_c$ . Once  $T_s$  and  $T_c$  are positioned with Tygon tubing covering about 75 percent of the glass, the tip can be sealed. Use of room temperature, vulcanizing, silicone cement works, but adhesion to Tygon surfaces is poor, and resealing must be performed before each use. The areas of  $T_s$  and  $T_c$  receive much mechanical disturbance under field conditions and will fail if any moisture enters. Therefore, the best approach is to embed  $T_c$  in the base as described above and heat-fuse the Tygon to  $T_s$  (Figure 5). Heat fusion is achieved by securing a gas-fired soldering iron under a dissecting microscope and holding the  $T_s$ -Tygon tip near the glowing base-furnace behind the soldering tip while rolling the thermistor tip for even heat distribution and fusion. Fusion will usually extend back from the glass tip about the wires and insulation to form a more secure and watertight tip. Care must be taken to not overheat and/or scorch the Tygon. It is difficult to salvage the  $T_s$  assembly if the fusion process fails; practice with heat-fusion of Tygon tubing to tiny glass rods or pipette tips will help refine the technique. Heat-fused tips have been used in excess of a year without failure. Leads from  $T_s$  and  $T_c$  are threaded through the acrylic base and soldered to the cable leads. A cable tie is tightened around the cable, fastened in the acrylic body with epoxy, and cured. The cable and prepared thermistors ( $T_s$  and  $T_c$ ) are potted with silicone cement in the acrylic base at opposite ends. Before each calibration and laboratory/field use, both ends of the acrylic body must be checked, and any loose silicone cement removed. A thin layer of silicone is carefully applied to ensure a watertight seal to cable, Tygon, and acrylic; excess cement is removed before curing.

During use, it is also important to prevent excess stress at the point where the cable enters the acrylic body. This is achieved by securing the acrylic body to an aluminum rod with Velcro (see Figures 7d and 7e). The aluminum rod not only provides support to the cable connection, but it also provides a necessary handle for securing the probe in the calibration chamber and for manipulation of the probe in the field.

## Calibration System

Reliable calibration of the thermistor current meter under conditions of laminar flow is critical. Construction of a reliable and accurate system was one of the greatest challenges for this project. Calibration is achieved with a system which modifies and combines designs from Vogel (1981) and Muschenheim, Grant, and Mills (1986). The following criteria were central to the development of the calibration system: accurate calibration; compact unit for storage and use in limited laboratory space; leak-proof system for routine use where water accidents are intolerable; inexpensive design requirement for readily available materials; and construction requirements for the use of hand tools.

Details of the calibration system are given in Figures 1 through 4 and Figures 7a, 7b, 7c, and 7f. Figure 1 provides the overall schematic for the calibration system giving the direction of flow and describing details for adjusting flow; Figures 7a, 7b, 7c, and 7f show a compact practical laboratory setup in use. It is important that the water reservoir and plastic pails are heavy duty and will not warp when filled with water. It is also convenient for the pails of the constant pressure and overflow containers to have side walls which are perpendicular to their base. Specimen pails (see Figure 7) work best but need to have the outer rim-ridges removed with a Dremel tool to accommodate pipe fittings. Actual laboratory setup can be condensed by using a large plastic industrial trash can for the water reservoir which is positioned beneath a wooden rack. The rack supports the plastic pail and a burette stand to secure the flow sensor at the opening of the laminar flow pipe. Volume of water (graduated cylinder) per unit time passing through the known cross-sectional area of the laminar flow pipe determines the calibration velocity. Velocity is adjusted by augmenting the screw clamp on the tubing which leads to the baffle chamber. Velocity is maintained by augmenting the screw clamp on the tubing providing water for continuous overflow and a constant pressure head in the plastic pail above the water reservoir. Adjusting height of pressure head and changing the diameters of pipe and tubing will alter the range of velocities which can be achieved. Figures 2 and 3 provide details of Figures 1a and 1b, respectively, along with a parts list. Tygon tubing over polyvinyl chloride (PVC) male screw adapters form tight seals, but an occasional small water drop may leak from these fittings during calibration since the screw fitting forms spiral rings instead of concentric rings. Silicone cement can be used to fill the open screw threads to eliminate this minor problem. The baffle chamber (Figures 1b and 3; Figure 7a) is critical for

removing turbulence and creating laminar water flow in the smooth, clear PVC pipe. The 3-in. pipe of the baffle chamber is filled with aquarium filter floss which is held in place by nylon screening. Some water will leak from the 3-in. PVC screw adapters which hold the nylon screen in place; this will collect in the reservoir. However, for accurate velocity control, it is essential that there are no leaks from the point where the clear PVC pipe is cemented in position (through modified PVC bushing) to where water is collected in a graduated cylinder. The clear PVC pipe must have perpendicular ends which are sanded and polished, and the pipe must be as short as possible to prevent the reestablishment of turbulent flow at the point where the thermistor probe is positioned in the calibration chamber. The stability of laminar flow can be easily checked by moving the probe across the open pipe and watching for variation in voltage readings on the meter. Velocity is calculated from the cross-sectional area of the smooth PVC pipe and the volume delivered (per unit time) to the graduated cylinder; cylinder size can be changed in accordance with the flow/volume to accommodate a wide range of velocities for calibration.

The importance of leak-proof construction and operation for accurate calibration cannot be overemphasized. Watertight fittings are required wherever pipe passes through container walls (Figures 1, 2, and 3). The modification of the PVC compression coupling to provide strong watertight seals is diagrammed in Figure 4. Cuts in the compression nuts and tube need to be parallel to finished ends and sanded. Tube length and threads/depth of nuts are not standardized among manufacturers so that it is usually necessary to cut two compression nuts to achieve the modification for sealed holes. Each hole in the pail wall should be tight to the threads of the compression tube. Once the modifications have been completed, the PVC pipe is placed in position through the rubber compression ring; aquarium silicone cement (SC) is used to caulk around the hole of the plastic pail on both sides against the threads of the compression tube. The cap end of the modified compression nut is tightened first to secure a watertight fit between PVC pipe, rubber compression ring, and modified compression tube. Modified compression nut end is then tightened against pail wall, pushing SC to form watertight seal between pail and modified compression coupling. Excess SC is then wiped off and allowed to cure. These strong watertight fittings are a must for the recirculating calibration system.

Reliable initial calibration and recalibration of the flowmeter requires a clean calibration system. Any foreign material in the system can either impede flow or interfere with flowmeter function. Water left in the system for prolonged periods will encourage the growth of an assemblage of microbial slime organisms which must be cleaned from the system with sodium hypochlorite prior to use. A clean system can be maintained by filling within 24 hr before calibration using new aquarium filter floss in the baffle chamber. After use, the calibration system should be drained, dried, the filter floss discarded, and the system covered.

The current meter circuit includes both the cable and thermistors ( $T_S$  and  $T_C$ ) (Vogel 1981). Each cable with its thermistors is a unique entity, and once balanced to the meter, they form a unified electrical circuit. The probe-cable units are not interchangeable. Probe-cable units of  $\leq 2$  to  $\geq 50$  m long have been used in the laboratory and field. Changing a probe-cable unit involves rebalancing the circuitry and recalibration of the current meter.

Calibration of the thermistor current meter involves electrically setting the resistors for specific voltages, balancing the circuitry for  $\pm 6$  °C of expected temperatures (using two temperature baths 12 °C apart), and zeroing the meter to still water. Vogel (1981) details the specific steps for achieving an electrically balanced circuit using still water at the extremes of the expected temperature range. Once the circuitry is balanced and zeroed, the probe is positioned in the calibration system (Figures 1, 3, 5, and 7), and voltages are recorded for a range of velocities. A typical calibration is illustrated in Figure 6. The high positive correlation ( $r$  is usually between 0.95 and 0.99) between voltage and velocity depends on stable electronics, the accurate control of calibration velocities, and maintenance of laminar flow in the calibration system. Recalibration of the current meter should take place several days before taking measurements in the field. Daily checking of calibration would be ideal; however, this is not always practical. Careful handling of the equipment is needed to prevent alterations in settings and is critical for maintaining the reliability of the calibration over time. Experience using the meter and a particular probe builds confidence and decreases likelihood of accidents. Usually, there is consistent recalibration to the same or a similar relationship between voltage and velocity.

## Power Sources and Data Collection

The thermistor current meter is extremely flexible with respect to power sources and data recording. In the laboratory, power can be supplied from a standard 110-V electrical outlet through an AC/DC power supply which delivers 18 V. In the field, the current meter is powered with both 9-V and 6-V, alkaline, dry cell batteries. A compact power pack (the elongate black box on top of the current meter in Figure 7a) can be constructed using snap terminal connectors for four 9-V dry cells, a plastic project box, and a minijack connector. A soldered harness of the terminal connectors provides two sets of two, in-series, 9-V batteries which are wired in parallel to deliver 18 V of power for 4 to 6 hr of measurements. Extra packs can be prepared in advance, or batteries can be quickly changed in the field or laboratory. Velcro tape is used to secure the battery pack to the top of the meter, and a short two-wire cable with jacks on each end connects the power pack to the meter. Power for field monitoring of water velocities in excess of 6 hr can be supplied using six 6-V dry cells. Two sets of three, in-series, 6-V dry cells are wired in parallel to deliver 18 V of power for greater than 24 hr of operation. The 6-V batteries

are connected using a presoldered wire harness with alligator clips. The alligator clips connect the battery terminals to a two-wire cable with a jack which attaches to the current meter. It is also possible to connect the current meter to solar cells for long-term field use.

The current meter has a digital LCD panel from which voltages can be directly read. Six to ten voltage readings are typically recorded at 10-sec intervals; the mean is then used as the average voltage for the time interval. The variance in voltage is an indicator of relative turbulence (the variance is directly correlated to turbulence around the sensing thermistor). More accurate voltage measurements can be made by connecting the current meter to either a strip-chart recorder (laboratory) or datalogger (laboratory or field). The current meter has been successfully connected directly to a LI-COR Model L1000 datalogger. The datalogger automatically records voltages at user-specified intervals (as short as 1 sec). The datalogger can time-stamp all readings, record running averages, and record minimum and maximum values over user-specified time intervals. These data can be downloaded to a portable microcomputer for analyses. The current meter/datalogger system was used to make continuous 48-hr in situ measurements of water velocities in Hawaiian rainforest streams.

## Field and Laboratory Examples

The thermistor current meter has been used to measure velocities in the water column and around various substrate features in riverine habitats. These data were used to determine spatial patterns of benthic velocities and vertical velocity profiles. Figures 8 and 9 illustrate measurements taken with the current meter in rapids located in Honolii Stream, a high-gradient rainforest stream on the island of Hawaii. In the smaller rapid (30-cm-deep, 1-m-wide), water velocities varied an order of magnitude over 30 vertical cm and ranged from  $21 \text{ cm s}^{-1}$  near the bottom to  $> 150 \text{ cm s}^{-1}$  at the surface (Figure 8). Measurements on the bottom near a goby, *Lentipes concolor*, and a group of atyid shrimp, *Atyoida bisulcata*, indicated that these organisms were experiencing velocities two to three times lower than velocities measured 10 cm above the bottom and were four to eight times lower than those measured at the water surface (Figure 8). Dye markers, small strips of plastic, and attached filamentous algae were used to determine the direction of water flow over the substrate. In the small rapid, a circular eddy was located directly beneath the bedrock lip; such water moved upstream on the bottom near the organisms (Figure 8). The rapid in Figure 9 was deeper (1 m) and broader (ca. 2 m) than the smaller rapid (Figure 8), but water column velocities were lower. Velocities on the upstream face of the large rapid were three times less than those at the surface. A *L. concolor* oriented perpendicular to an upstream-directed water flow in an eddy at the base of the rapid face was experiencing a  $94\text{-cm s}^{-1}$  velocity directed towards its upstream side and  $19\text{-}$  and  $26\text{-cm s}^{-1}$  velocities on its downstream side; velocities were  $81 \text{ cm s}^{-1}$  1 cm above the dorsal fin of the fish (Figure 9).



More detailed spatial velocity measurements were made in streams by dividing a habitat into small grid cells. With fine spatial scales (e.g., grid sizes of 200 to 300 cm<sup>2</sup> or less) and repetitive sampling under varying water flow conditions, insights into relationships between various spatial and temporal characteristics of microhabitat velocities were made. Two-dimensional raster images illustrate water velocities at the surface and bottom of a small run (1 m across and 30 to 70 cm deep at a discharge rate of 43 cfs) in Honolii Stream, Hawaii (Figure 10). The habitat was divided into six transects spaced 20 cm apart with velocity measurements taken every 20 cm along a transect 1 cm below the water surface and 1 mm off the bottom. Intensity of color is directly correlated to water velocity, and black indicates two rocks which bound this small run (Figure 10). It was possible to detect patterns of water movement around rocks and velocities which varied an order of magnitude from the surface to the bottom. Much of the variation in velocities in the habitat was due to the extremely heterogeneous substrate of bedrock and medium to large cobble. The substrate altered water flow over very small spatial scales creating complex patterns of water movement in the water column (Figure 10).

The current meter can also be used to monitor changes in habitat velocities over prolonged time periods. Figure 11 shows 6 hr of continuous water velocity measurements made on the bottom of a small run (ca. 1.5 m wide by 0.5 m deep) in Makamaka'ole Stream, Maui. The current meter was attached to a datalogger which recorded voltages every 10 sec. The data presented in Figure 11 represent mean, minimum, and maximum velocities over 10-min intervals. The data indicates a gradual increase in velocity resulting from rainfall in the higher elevation rainforest. The data is noteworthy in that it indicates that moderate rainfall in the watershed did not result in a sudden pulsing of water in the stream, but it did result in a gradual increase in velocities over the time course of the recordings (Figure 11). The data also indicate that this microhabitat is not a velocity "refuge" in that velocities change considerably over short temporal scales.

The current meter has been used to determine ambient velocity profiles around a variety of benthic stream organisms including gobiid fishes, atyid shrimp, neritid snails, larval chironomids, and larvae caddisflies. These data can provide insights into the distribution, abundance, feeding patterns, reproduction, and behavior of the organism. Additionally, these data can be used to determine the spatial and temporal relationships between benthic velocities encountered by an organism in its daily life and velocities elsewhere in the water column. The understanding of these relationships is important for successfully predicting biological impacts because of alterations in stream flows.

Figure 12 provides velocity measurements around bodies of the goby, *Lentipes concolor*, from Honolii Stream, Hawaii. The three fish in Figure 12 were territorial males 5 to 7 cm in total length living on a bedrock, cobble substrate in a small rapid/run (water depth ca. 0.5 m). The fish were oriented perpendicular to stream flow when at rest in their respective territories. Note that for the three fish, there was a significant reduction in

velocities from the upstream to the downstream side of the fish; the nose velocities were also significantly different from velocities 2 cm in front of the fish (Figure 12). Velocities in the water column 5 cm above the fish ( $> 1.2 \text{ m s}^{-1}$ ) were three to four times greater than velocities around the fish (Figure 12). These data indicate that the fish are located in a habitat in which velocities vary over very small spatial scales (centimeters) and that the fish were utilizing a velocity refuge in which local velocities were significantly less than velocities in the surrounding water column.

Field measurements for spot velocities around the stream limpet, *Neritina granosa*, in Hakalau Stream, Hawaii, are illustrated in Figure 13. The limpet was oriented parallel to water flow with its head facing upstream in a shallow run with ambient substrate velocities of  $75 \text{ cm s}^{-1}$  and surface water velocities of  $96 \text{ cm s}^{-1}$ . Water velocities 1 mm above the shell were significantly lower than both ambient bottom, middepth, and surface velocities. Velocities increased significantly from the leading shell edge to the apex and from the apex to the trailing shell edge. Velocities recovered to ambient levels 12 cm downstream of the shell (Figure 13).

The current meter can also be used to precisely define the microhabitat characteristics of benthic stream organisms. The endemic Hawaiian caddisfly, *Cheumatopsyche analis*, is known to be found in high velocity runs and rapids in rainforest streams. The current meter was used to determine the specific velocity characteristics of habitat of *C. analis* in Honolii Stream, Hawaii. Figure 14 gives velocity profiles (surface, middepth, and bottom) for transects separated by only 10 cm. One transect has *C. analis* densities  $> 150 \text{ m}^{-2}$ , while the upstream transect has densities  $< 10 \text{ m}^{-2}$ . The profiles indicate that bottom velocities along the transect with abundant *C. analis* are  $> 60 \text{ cm s}^{-1}$  and significantly greater than bottom velocities 10 cm upstream which are all  $< 10 \text{ cm s}^{-1}$  (Figure 14).

## Conclusions

The thermistor current meter and probe are unique instruments which can provide exacting measurements of velocities with spatial resolutions of less than 2 mm. The current meter/probe can provide much needed data on a quantification of spatial variation in velocity regimes in both lotic and lentic habitats (these types of data can provide insights into the dynamics of water movement on a fine scale); temporal variation in velocities within a microhabitat; the effects of short- and long-term disturbance events on the velocities in a microhabitat; a quantification of the velocities encountered by an animal or plant through space and time; and an understanding of the relationship between gross habitat velocities and velocities encountered on a microscale by an organism. These data can provide information on the distribution, abundance, ecology, and behavior of important lotic and lentic organisms and provide the basis for decisions on the management of water flows in critical habitats.

## References

---

- Barmuta, L. A. (1990). "Interaction between the effects of substratum, velocity and location in stream benthos: An experiment," *Australian Journal of Marine and Freshwater Research* 41, 557-573.
- Burky, A. J., Way, C. M., and Lee, M. T. (1991). "The relationship between instream flow and shell morphology of the endemic snail (Hihiwai), *Neritina granosa*, in Hawaiian streams," *Bulletin of the North American Benthological Society* 8, 111.
- Burky, A. J., Way, C. M., Miller-Way, C. A., and Lee, M. T. (1990). "The use of a thermistor-based current meter to define flow-habitat relationships of the endemic Hawaiian goby, *Lentipes concolor* (Gill)," *Bulletin of the North American Benthological Society* 7, 82.
- Chance, M. M., and Craig, D. A. (1986). "Hydrodynamics and behavior of simuliidae larvae (Diptera)," *Canadian Journal of Zoology* 64, 1295-1309.
- Davis, J. A., and Barmuta, L. A. (1989). "An ecologically useful classification of mean and near-bed flows in streams and rivers," *Freshwater Biology* 21, 271-282.
- Denny, M. (1988). *Biology and mechanics of the wave-swept environment*. Princeton University Press, Princeton, NJ.
- \_\_\_\_\_ (1989). "A limpet shell shape that reduces drag: Laboratory demonstration of a hydrodynamic mechanism and an exploration of its effectiveness in nature," *Canadian Journal of Zoology* 67, 2098-2106.
- Frenia, D. K., Harding, J. M., Trail, M. L., Scott, S. B., and Burky, A. J. (1992). "The relationship between flow and habitat of the crayfish, *Orconectes rusticus*, in an Ohio river," *Bulletin of the North American Benthological Society* 9, 164.
- Harding, J. M., and Burky, A. J. (1993). "Habitat preferences of the rainbow darter, *Etheostoma caeruleum*, in a central Ohio river with regard to water column and benthic flow," Manuscript submitted to *Journal of the North American Benthological Society*.

- Harding, J. M., Frenia, D. K., Trail, M. L., Scott, S. B., and Burky, A. J. (1992). "Habitat preferences of the rainbow darter, *Etheostoma caeruleum*, with regard to benthic flow," *Bulletin of the North American Benthological Society* 9, 67.
- LaBarbera, M., and Vogel, S. (1976). "An inexpensive thermistor flowmeter for aquatic biology," *Limnology and Oceanography* 21, 750-756.
- Losee, R. F., and Wetzel, R. G. (1988). "Water movement within submersed littoral vegetation," *Verh. Internat. Verein. Limnol.* 23, 62-66.
- MacIntyre, S. (1986). "A flow-measuring system for use in small lakes," *Limnology and Oceanography* 31, 900-906.
- Murvosh, C. M. (1991). "The torrential insect fauna of North America," *Bulletin of the North American Benthological Society* 8, 322-327.
- Muschenheim, D. K., Grant, J., and Mills, E. L. (1986). "Flumes for benthic ecologists: Theory, construction and practice," *Marine Ecology Progress Series* 28, 185-196.
- Statzner, B. (1988). "Growth and Reynolds number of lotic macroinvertebrates: A problem for adaptation of shape to drag," *Oikos* 51, 84-87.
- Statzner, B., and Higler, B. (1986). "Stream hydraulics as a major determinant of benthic invertebrate zonation patterns," *Freshwater Biology* 16, 127-139.
- Statzner, B., and Holm, T. F. (1989). "Morphological adaptations of shape to flow; microcurrents around lotic macroinvertebrates with known Reynolds numbers at quasi-natural flow conditions," *Oecologia* 78, 145-157.
- Statzner, B., Resh, V. H., and Gore, J. A. (1988). "Hydraulic stream ecology: Observed patterns and potential applications," *Bulletin of the North American Benthological Society* 7, 307-360.
- Trail, M. L., Harding, J. M., Frenia, D. K., Scott, S. B., and Burky, A. J. (1992). "The habitat-flow relationship of the mottled sculpin, *Cottus bairdi*, in a central Ohio river," *Bulletin of the North American Benthological Society* 9, 165.
- Vogel, S. (1981). *Life in moving fluids: The physical biology of flow*. Willard Grant, Boston.
- \_\_\_\_\_ (1988). *Life's devices: The physical world of animals and plants*. Princeton University Press, Princeton, NJ.

- Way, C. M., Bingham, R., Miller, A., and Burky, A. J. "Effects of surface structure of articulated concrete mattress blocks on physical and biological conditions," Technical Report in preparation, U.S. Army Engineer Waterways Experiment Station, Vicksburg, MS.
- Way, C. M., and Burky, A. J. (1992a). "Preliminary characterization of habitat of an endemic goby (o'opu alamo'o), *Lentipes concolor* (Gill), in relation to water column and benthic flow in Hawaiian streams." *Proceedings: New directions in research, management and conservation of Hawaiian freshwater stream ecosystems*. 165-174.
- \_\_\_\_\_. (1992b). "The effects of stream flow on benthic organisms in torrential streams: A conceptual dilemma in space and time," *Bulletin of the North American Benthological Society* 9, 162.
- \_\_\_\_\_. (1993). "The effect of water velocity on the distribution of the larvae of the endemic chironomid, *Telmatogeton torrenticola* (Terry), from Honolii Stream, Hawaii," Manuscript submitted to *Journal of the North American Benthological Society*.
- Way, C. M., Burky, A. J., and Lee, M. T. (1991). "The importance of spatial and temporal scales in flow to the biology of the Hawaii stream goby, *Lentipes concolor*," *Bulletin of the North American Benthological Society* 8, 134.
- \_\_\_\_\_. "The relationship between shell morphology and microhabitat flow in the endemic Hawaiian stream limpet ('hihiwai'), *Neritina granosa* Sowerby (*Prosobranchia: Neritidae*)," *Pacific Science* (In Preparation).
- \_\_\_\_\_. (1993). "A new methodology for determining instream flows and habitat utilization in torrential streams," Manuscript submitted to *Rivers*.
- Weisenberger, J., Spatz, H. Ch., Emanns, A., and Schwerbel, J. (1991). "Measurements of lift and drag forces in the mN range experiences by benthic arthropods at flow velocities below  $1.2 \text{ m s}^{-1}$ ," *Freshwater Biology* 25, 21-31.

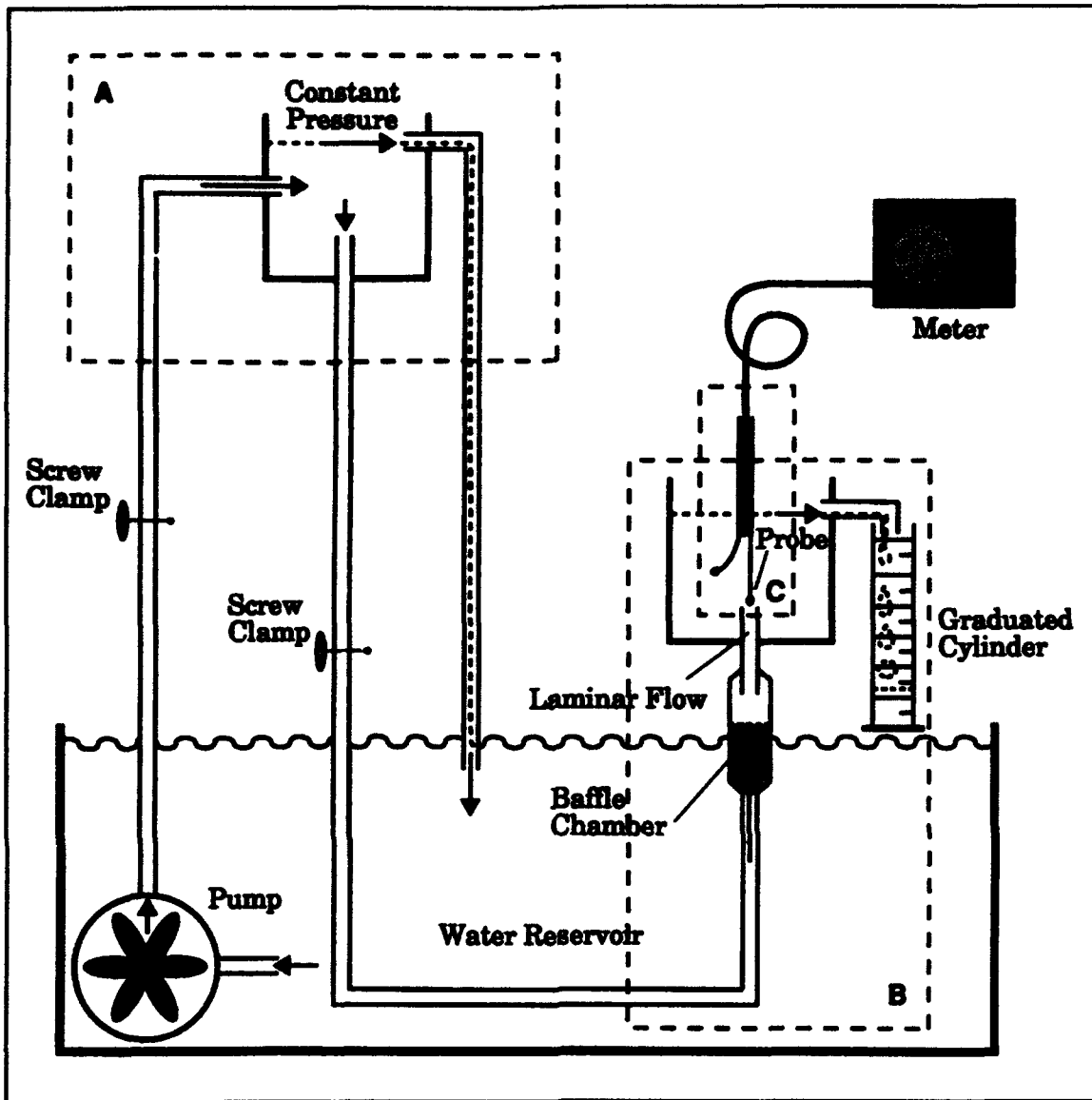
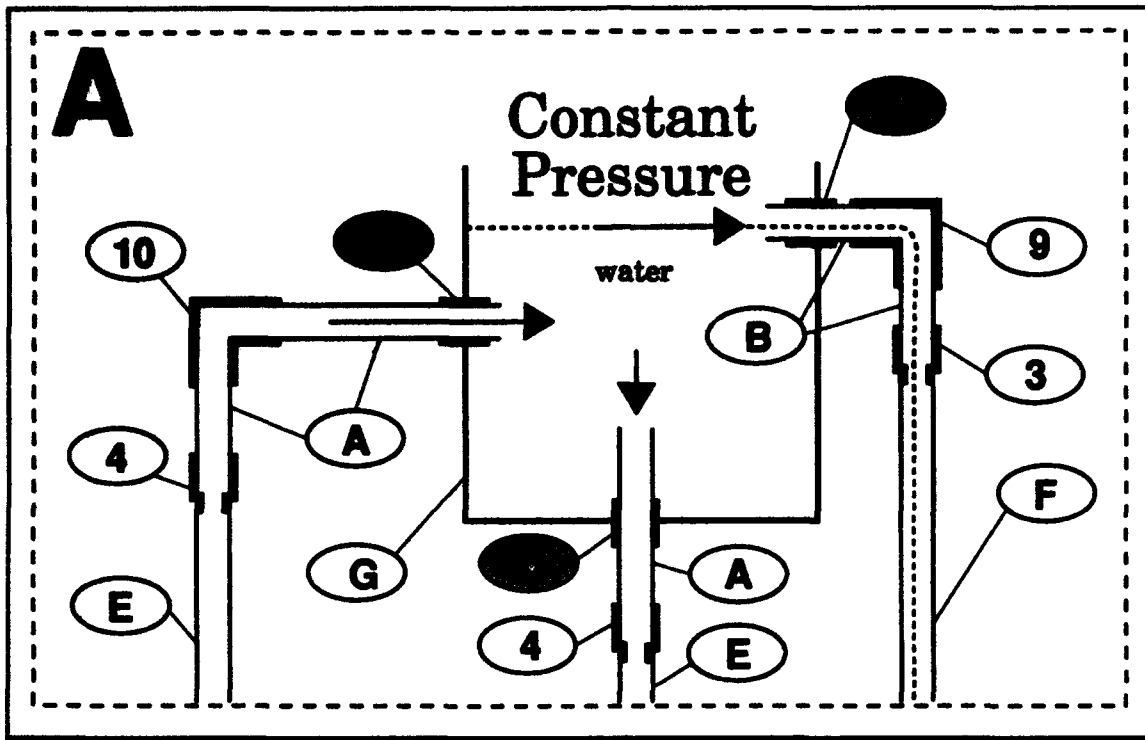

Figure 1. Calibration System for thermistor flow meter. Outline box A represents the constant pressure head which is maintained by continuous overflow through the use of a fountain pump (Silent Giant Model 3E12NR). Outline box B represents where controlled laminar flow is achieved. Outline box C gives the position of the thermistor flow sensor during calibration. Details of boxes A, B, and C are provided in following figures



**Explanation of Circled Labels**

1. 3-in. PVC SCH male adapter	A. 3/4-in. PVC pipe
2. 3-in. PVC SCH female adapter	B. 1-in. PVC pipe
3. 1-in. PVC SCH male adapter	C. 1-in. R4000 clear PVC pipe
4. 3/4-in. PVC SCH male adapter	D. 3-in. PVC pipe
5. Modified 1-in. PVC compression coupling	E. Tygon tubing (1-in. ID, 1-1/4-in. OD)
6. Modified 3/4-in. PVC compression coupling	F. Tygon tubing (5/8-in. ID, 7/8-in. OD)
7. Modified 1-1/2 by 1-in. PVC bushing	G. 5-gal heavy-duty plastic pail
8. 3-in. slip by 1-1/2-in. PVC reduction coupling	S. Nylon screen
9. 1-in. 90-deg PVC adapter elbow	AF. Aquarium filter floss
10. 3/4-in. 90-deg PVC adapter elbow	
11. 1-1/2- by 3/4-in. PVC bushing	

**Figure 2.** Details of Figure 1 (dashed outline box A) giving components for construction. Continuous overflow level maintains pressure head for constant flow. All PVC slip fittings are fused with PVC plumbing cement. All Tygon tubing to PVC pipe are tension connections of flexible tubing over threaded ends of PVC adapters. Modifications of 5 and 6 are presented in Figure 4

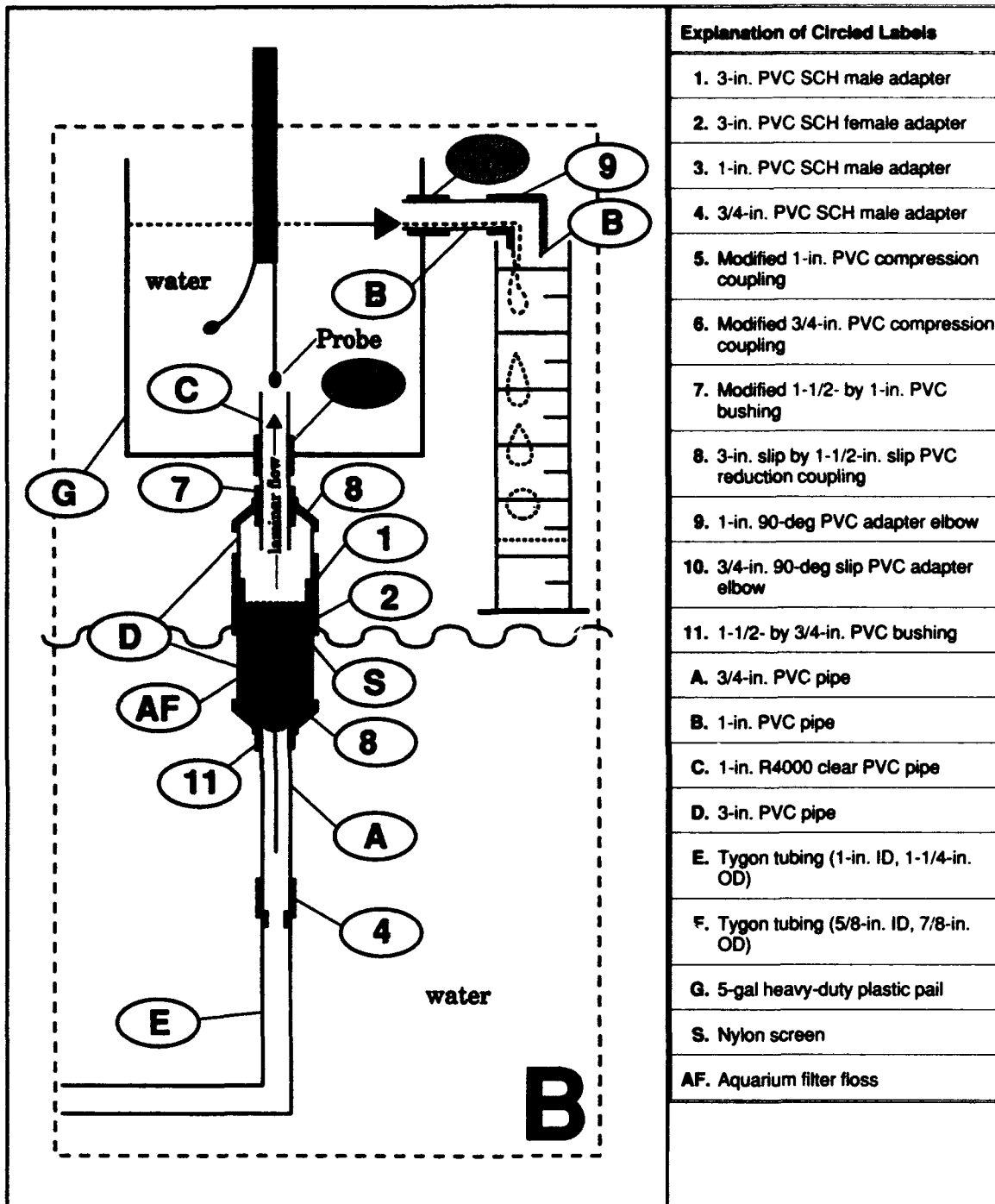

Figure 3. Details of Figure 1 (dashed outline box **B**) giving components for construction. Laminar flow is achieved at the point where the sensor thermistor (probe) is positioned. Careful increase of the bore of 7 (1-1/2- by 1-in. PVC bushing) allows snug fit of C (1-in. clear PVC pipe) which must pass through bushing. It is fused in place with PVC plumbing cement. All PVC slip fittings are fused with PVC plumbing cement. Modifications of 5 are presented in Figure 4



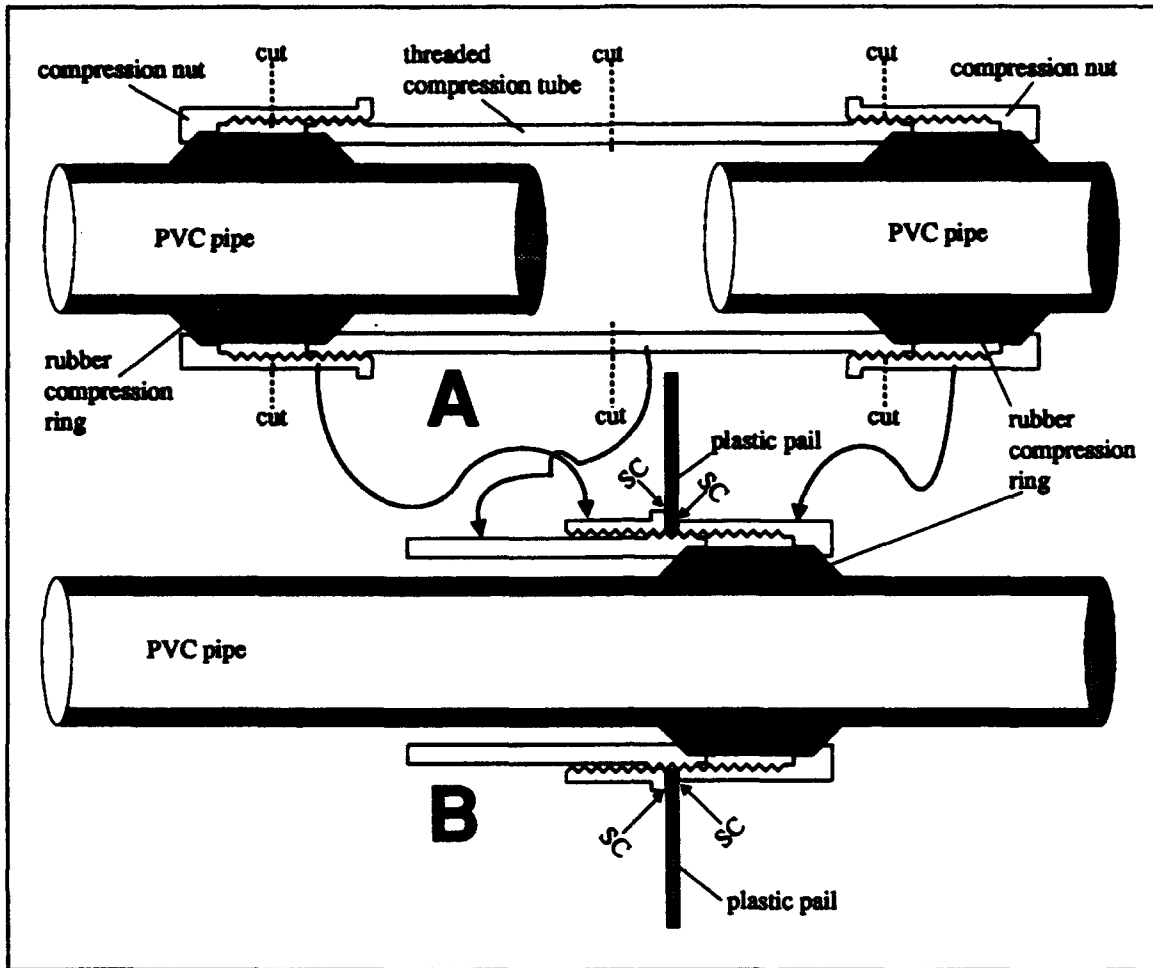
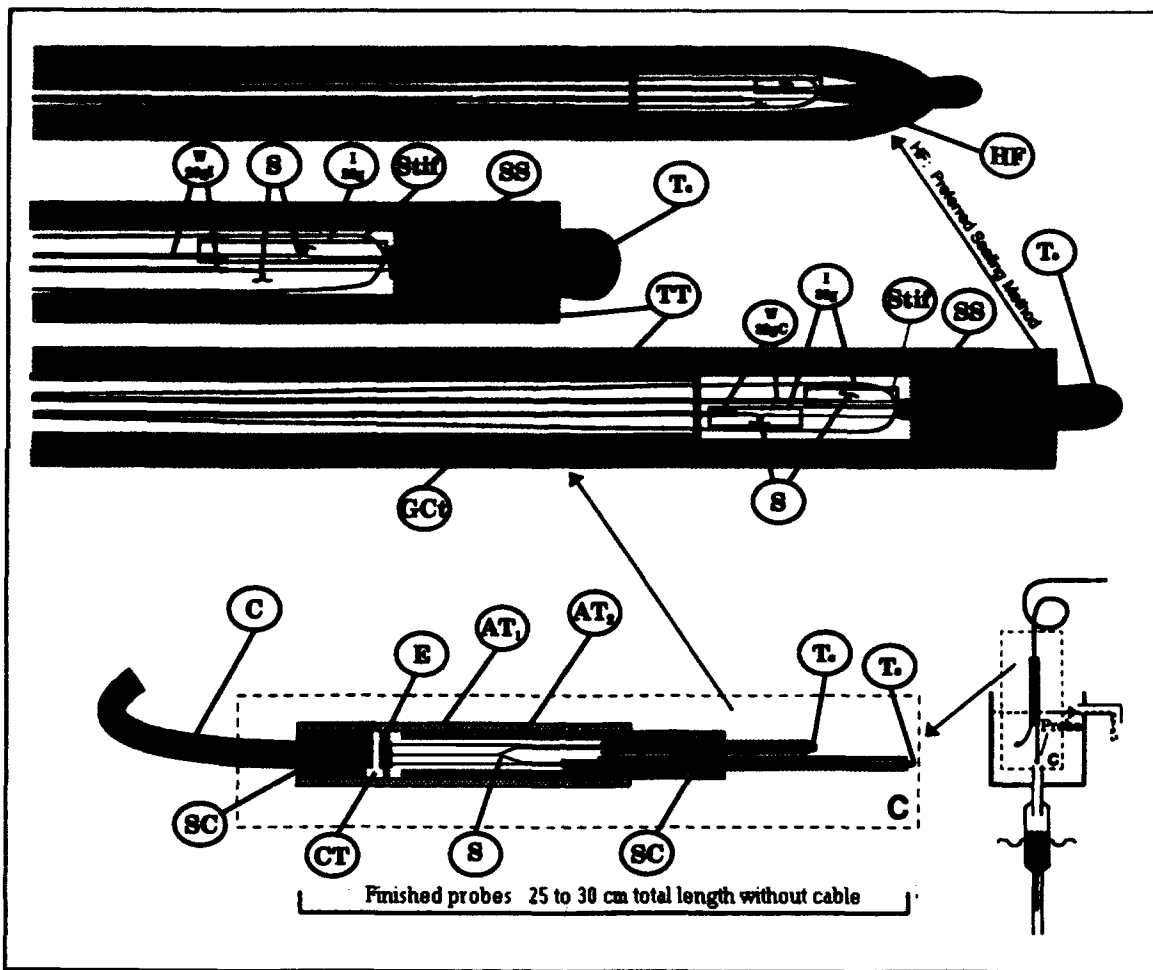

Figure 4. Modification (B) of PVC compression coupling (A) to form strong watertight SC seals where PVC pipe passes through walls of plastic pails (Figures 1, 2, and 3) of calibration system



**Explanation of Circle Labels**

<b>W:</b> solid electrical wire	<b>TT:</b> Tygon tubing (1/16-in. ID, 1/8-in. OD)
<b>#g:</b> wire gauge	<b>AT<sub>1</sub>:</b> acrylic tubing (5/8-in. ID, 7/8-in. OD)
<b>#gC:</b> coated wire	<b>AT<sub>2</sub>:</b> acrylic tubing (3/8-in. ID, 5/8-in. OD)
<b>I:</b> insulated wire or insulation from wire	<b>SC:</b> silicone cement (aquarium sealer)
<b>Stif:</b> stiffener wire (optional)	<b>SS:</b> silicone sealant (Dow Corning room temperature vulcanizing rubber)
<b>CT:</b> nylon cable tie	<b>GCt:</b> stainless steel gas chromatograph tubing [0.046-in. ID, 0.062 (1/16)-in. OD]
<b>C:</b> shielded 3 conductor cable	<b>HF:</b> heat-fusion seal of Tygon tubing to glass-bead thermistor
<b>E:</b> epoxy cement	<b>T<sub>s</sub>:</b> sensor glass bead (VECO 21A14)
<b>S:</b> solder connection	<b>T<sub>c</sub>:</b> compensator glass bead (VECO 33A38)

Figure 5. Details of Figure 1 (dashed outline box C) giving components for a field-ready probe. Top diagram shows the result of the preferred watertight heat-fusion method of sealing sensor. See text for details

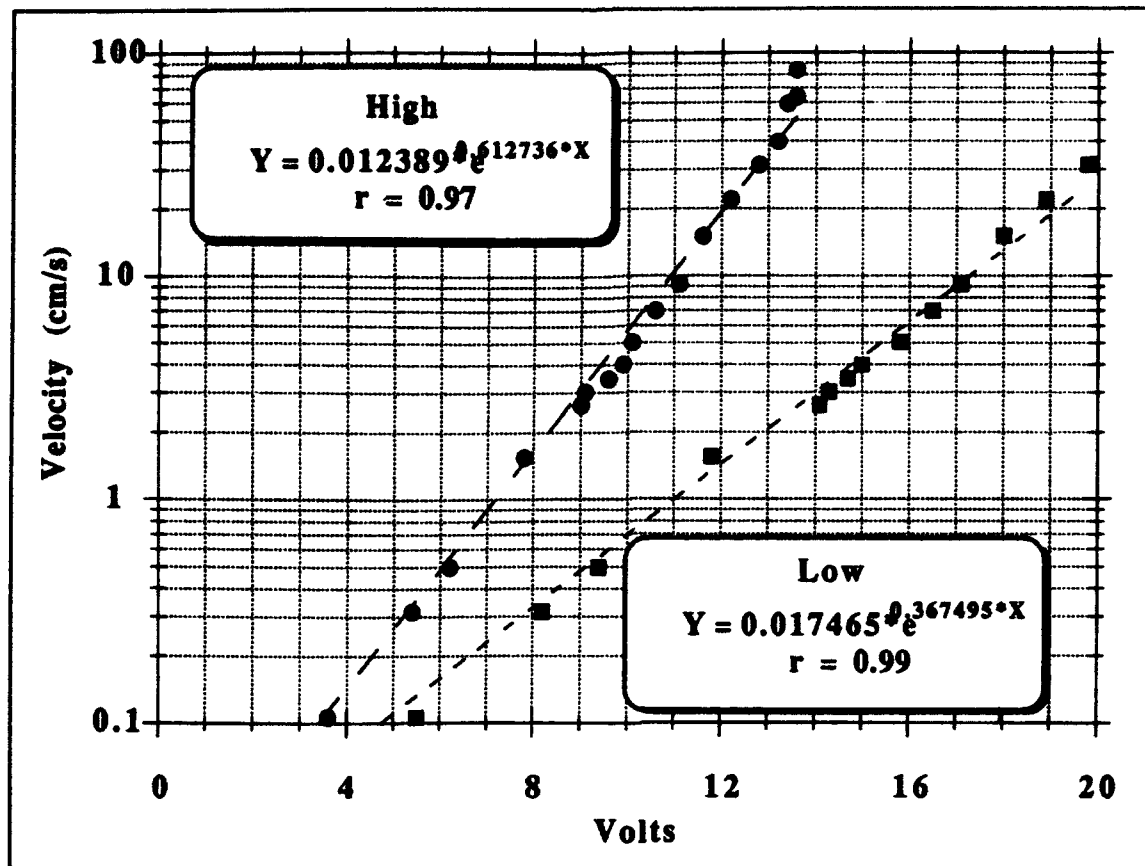
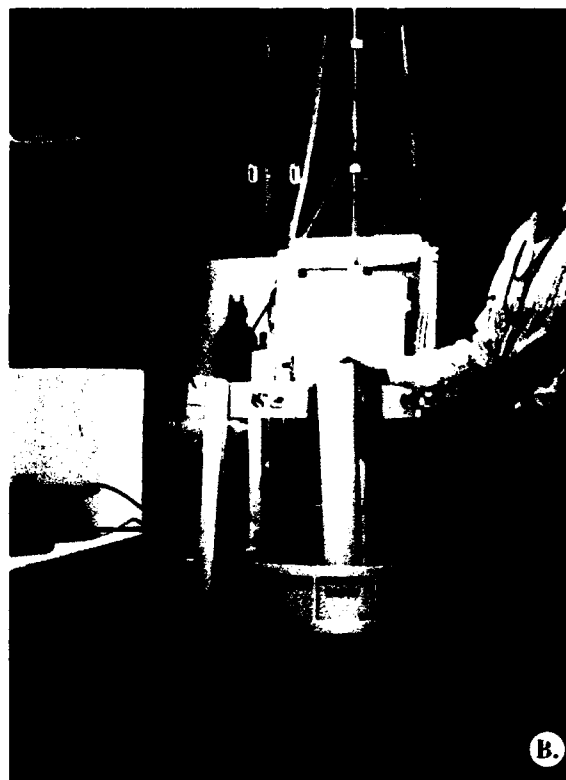

Figure 6. Typical calibration of thermistor flowmeter. High and low range calibration relationships are achieved by switching resistors in the circuit. Greatest sensitivity and accuracy are achieved at lower water velocities



**Figure 7. Laboratory setup for thermistor current meter**

**A.** The constant pressure container is on two by four stand above wall cabinets. Probe is positioned in overflow container from a burette stand on two by four support; baffle chamber is suspended below overflow container over the water reservoir. Screw clamps are attached to each side for control of water pumped to constant pressure container (left) and flowing to the baffle chamber (right). Meter is positioned on white desk surface to left of two by four floor stand.

**B.** Water is being collected from the overflow container for a timed period.

**C.** Top view is shown of overflow container with thermistor sensor positioned at middle of opening of laminar flow pipe; heavy duty screw clamps are attached to the wooden frame.



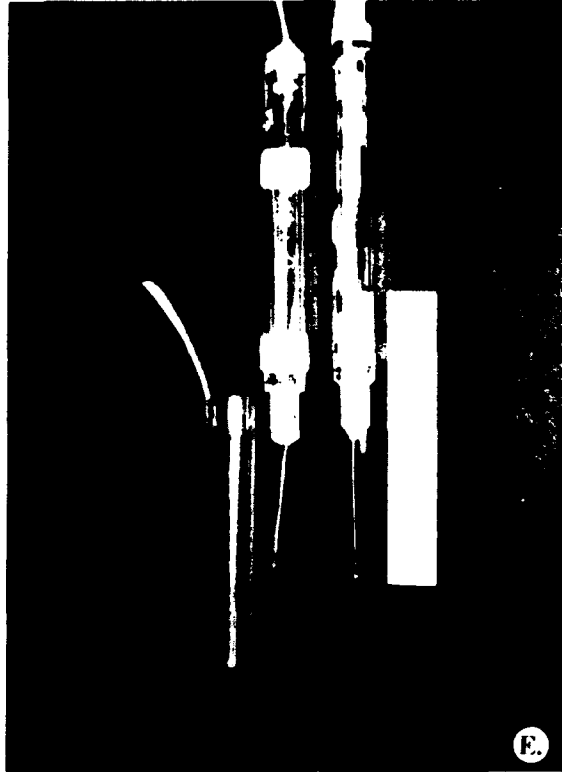
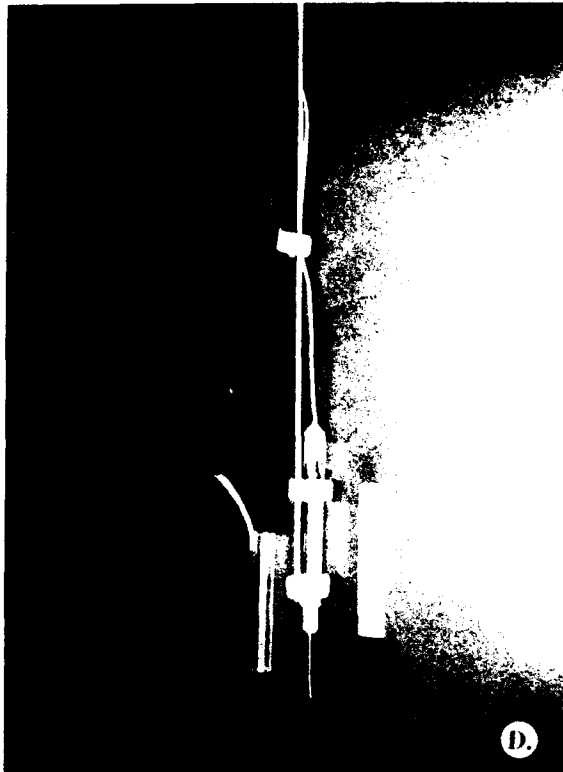
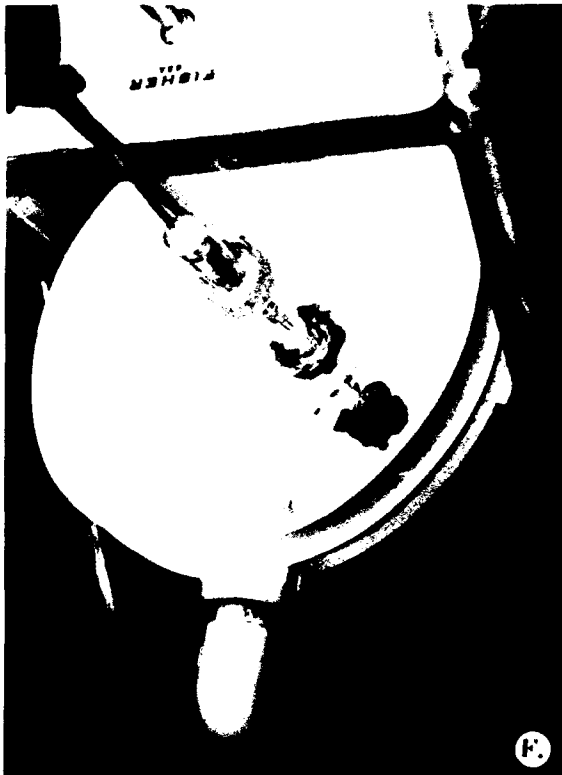

Figure 7. (continued)

D. Probe is attached to aluminum rod with Velcro. Velcro hook and eye straps are fabricated and attached to the rod with epoxy cement, and self-stick rings of Velcro eye tape are wrapped around the acrylic body of the probe. Velcro hook and eye straps form a self-wrap to secure the cord. Aluminum rod provides support to clamp probe in calibration system and for use under turbulent field conditions. Acrylic tube with Velcro is used to cover probe tip for protection during transportation.

E. Two versions of thermistor probe are shown. Probe at left has compensator resistor/thermistor molded into silicone cement at base with only resistor tip exposed; sensor has heat fusion seal at tip. Velcro eye tape is for fastening to aluminum rod. Probe at right has compensator resistor/thermistor extended from base.



F. Top view of overflow container with thermistor is shown.

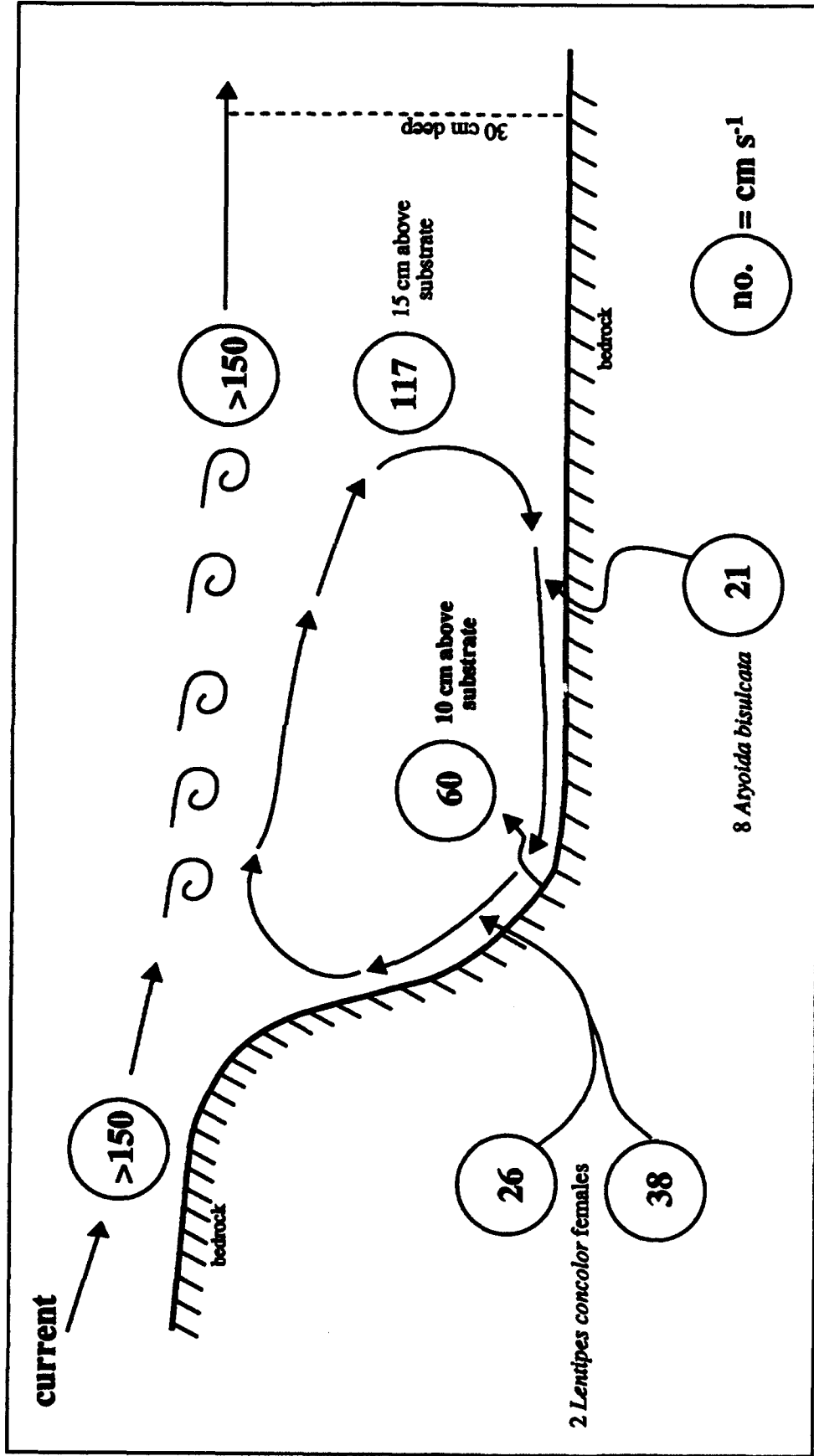

Figure 8. Velocity measurements taken in a small rapid in Holoii Stream, Hawaii. Measurements were taken 1 mm above the substrate surface, 1 cm below the water surface, and 1 mm away from goby, *Lentipes concolor*, and the atyid shrimp, *Atyoida bisulcata*

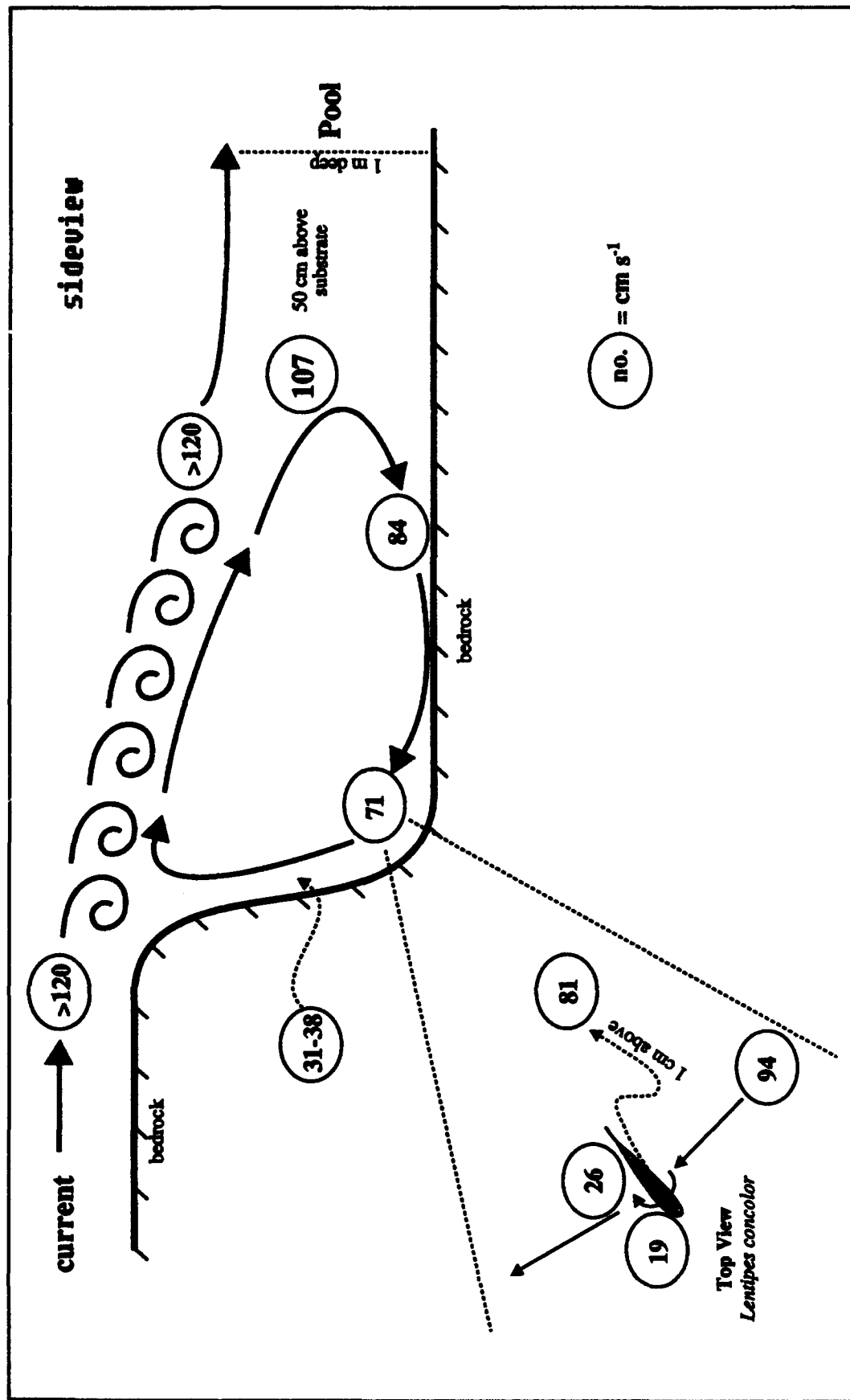
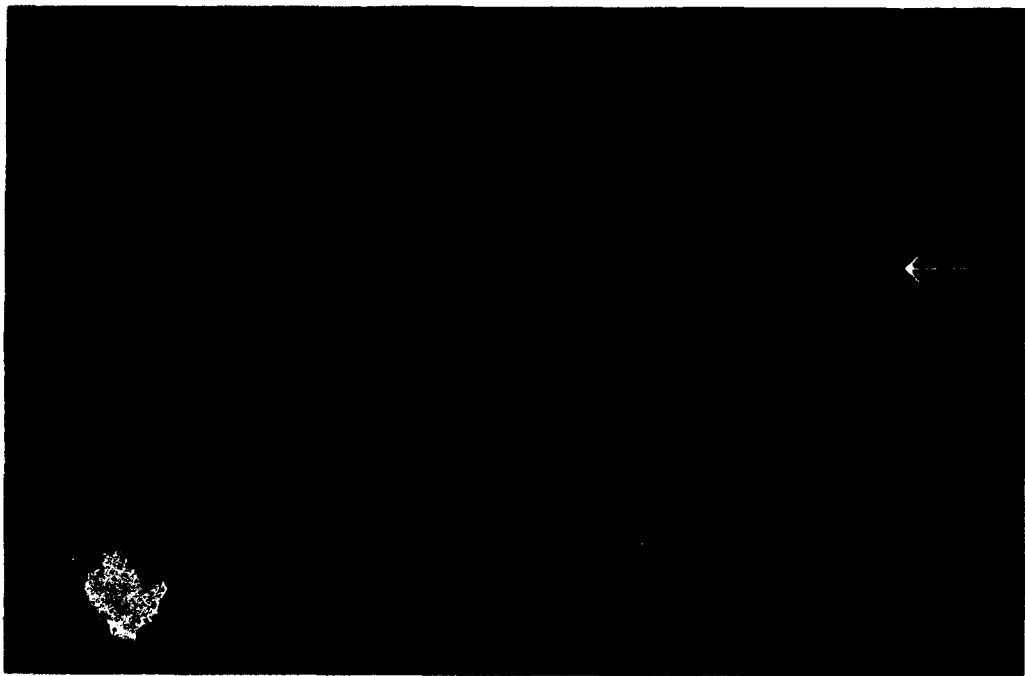
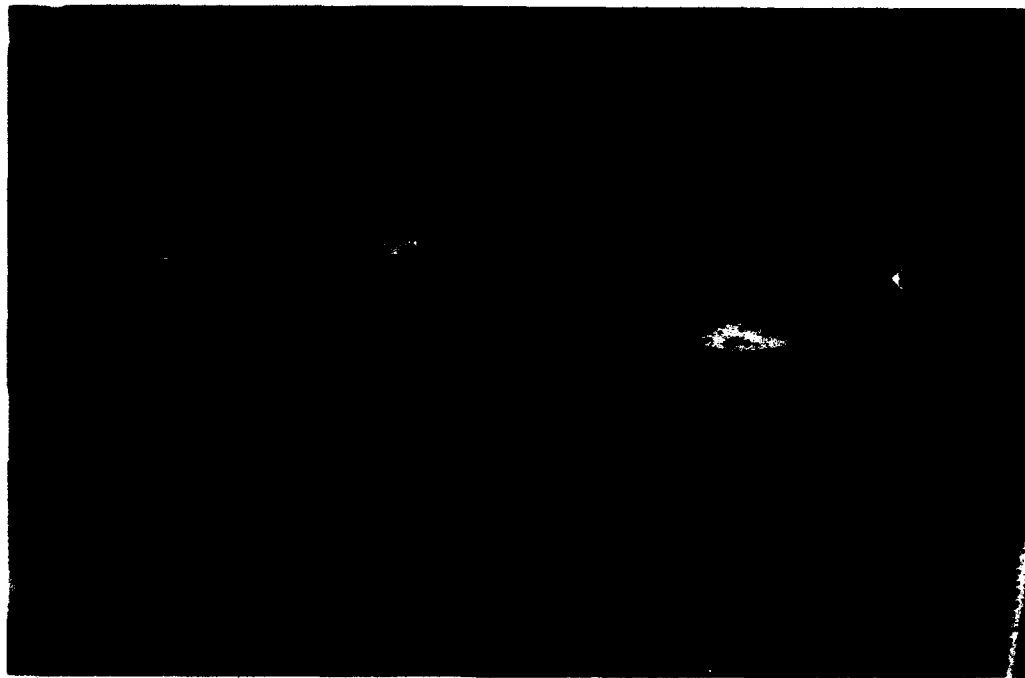

Figure 9. Velocity measurements taken in a large rapid in Honolii Stream, Hawaii. Measurements were taken 1 mm above the substrate surface, 1 cm below the water surface, and 1 mm away from the goby, *Lentipes concolor*



Velocity,  $\text{cm s}^{-1}$



Figure 10. Raster image of surface and benthic velocities in a small run in Honolii Stream, Hawaii. Intensity of color is directly related to the magnitude of water velocity. Black denotes large boulders which border the run. Direction of water movement is indicated by the white arrows



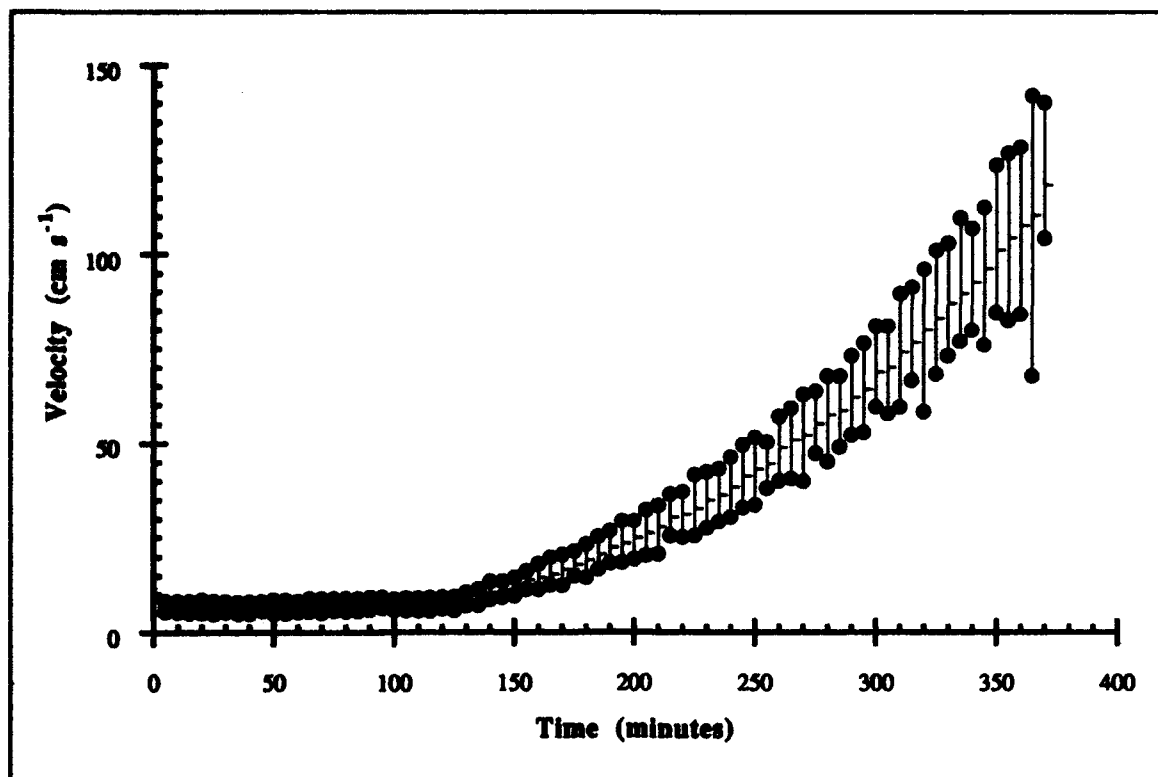

Figure 11. Velocity measurements for the bottom of a small run in Honolii Stream, Hawaii. Measurements were taken 1 mm above the substrate every 10 sec, and the plotted points represent the average, minimum, and maximum velocities over a 10-min interval

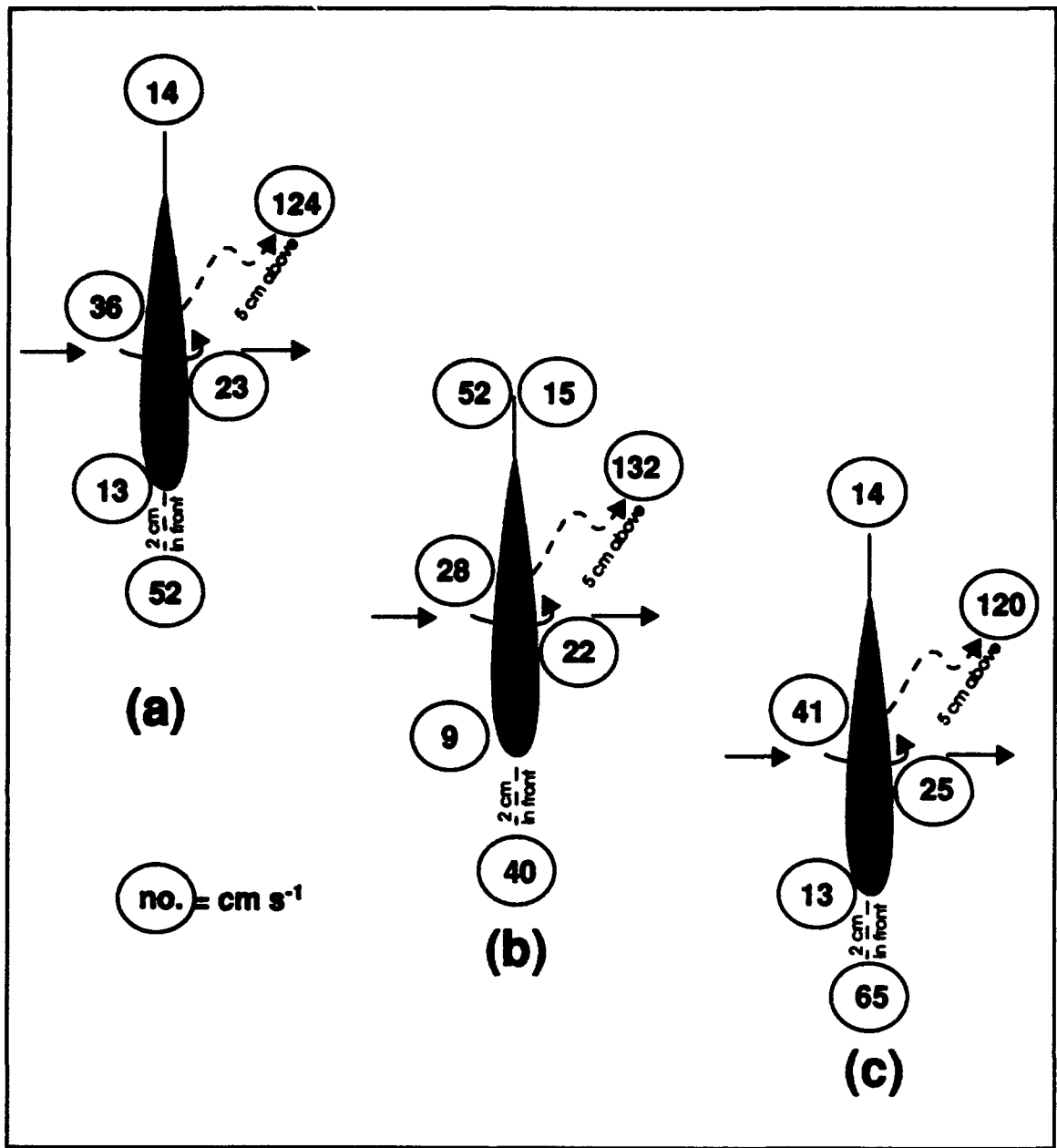

Figure 12. Velocity profiles measured in the water column and around male *Lentipes concolor* from a run in Honolii Stream, Hawaii. Measurements were taken either 1 mm from the body of the goby, 1 mm off the substrate, or at the indicated position in the water column

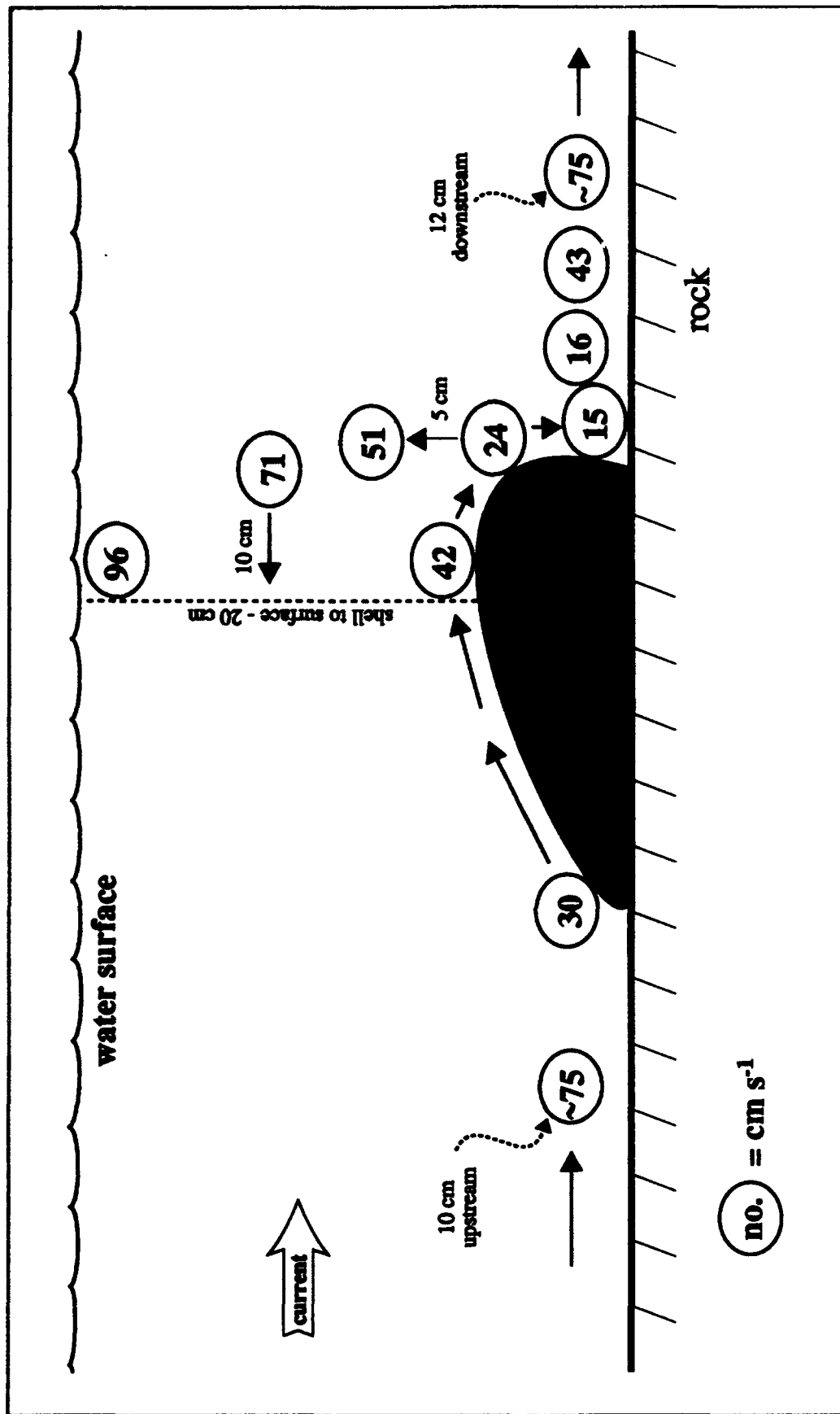

Figure 13. Velocity measurements in the water column and around a *Neritina granosa* located in a small run in Hakalau Stream, Hawaii. Measurements were taken either 1 mm off the rock surface, 1 mm above the limpet shell, or at the indicated positions in the water column. Values represent a mean of eight measurements taken at 10-sec intervals

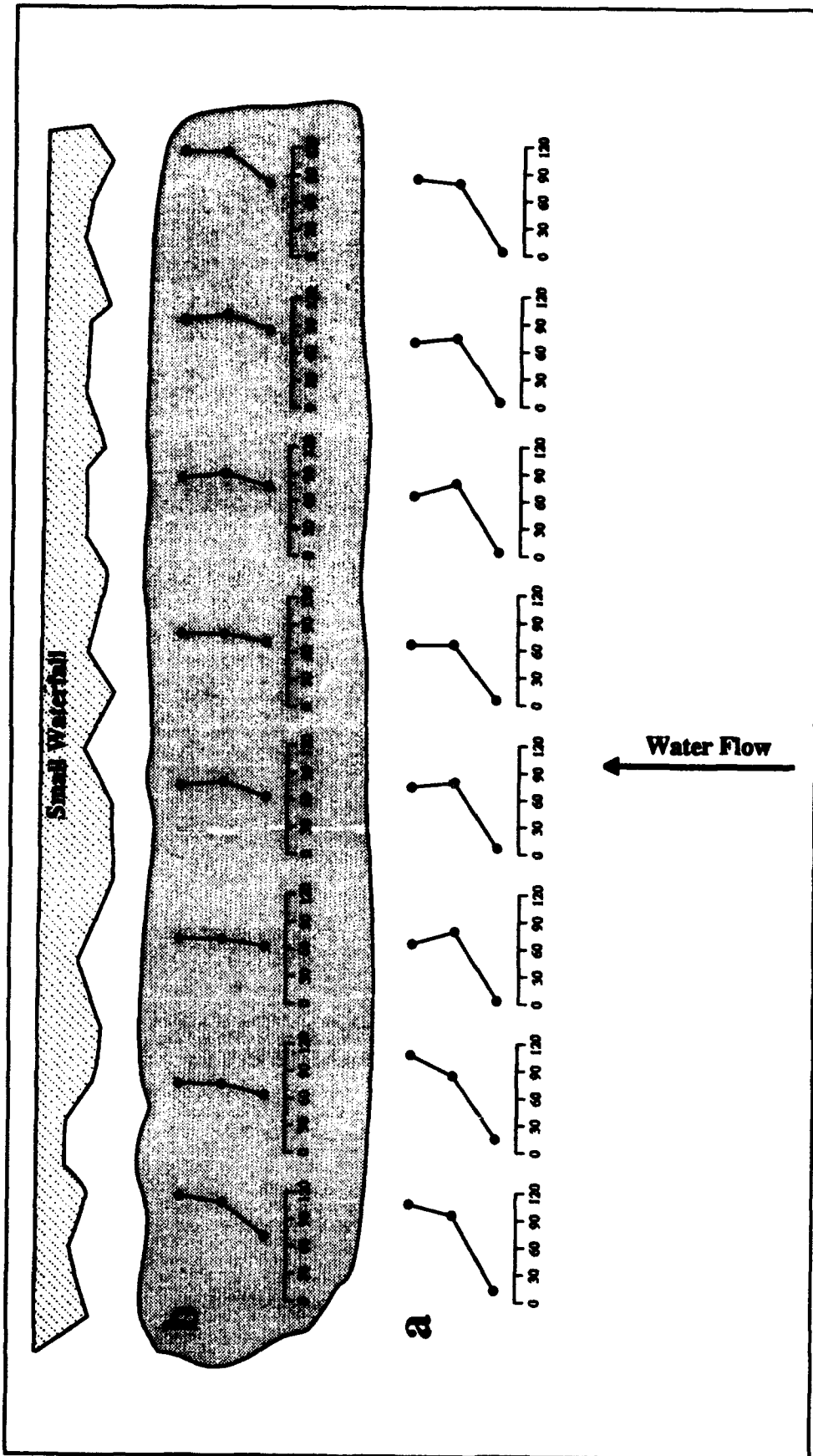

Figure 14. Velocity profiles along a transect for habitats with and without the endemic caddisfly, *Cheumatopsyche analis*, from a run in Honolii Stream, Hawaii. Each profile gives velocities (in centimeters per second) 1 cm below the water surface, at middepth, and either on the surface of an algal mat (a) or directly adjacent to a *C. analis* (b). Each profile along a transect was 10 cm apart, and the transects were 20 cm apart. The light gray region represents an area with abundant *C. analis*, while the transect upstream had no *C. analis*.

# REPORT DOCUMENTATION PAGE

Form Approved  
OMB No. 0704-0188

Public reporting burden for this collection of information is estimated to average 1 hour per response, including the time for reviewing instructions, searching existing data sources, gathering and maintaining the data needed, and completing and reviewing the collection of information. Send comments regarding this burden estimate or any other aspect of this collection of information, including suggestions for reducing this burden, to Washington Headquarters Services, Directorate for Information Operations and Reports, 1215 Jefferson Davis Highway, Suite 1204, Arlington, VA 22202-4302, and to the Office of Management and Budget, Paperwork Reduction Project (0704-0188), Washington, DC 20503.

1. AGENCY USE ONLY (Leave blank)		2. REPORT DATE January 1994	3. REPORT TYPE AND DATES COVERED Final report	
4. TITLE AND SUBTITLE Development and Application of a Thermistor Current Meter			5. FUNDING NUMBERS	
6. AUTHOR(S) Carl M. Way, Albert J. Burky, Christine A. Miller-Way				
7. PERFORMING ORGANIZATION NAME(S) AND ADDRESS(ES) U.S. Army Engineer Waterways Experiment Station, Environmental Laboratory, 3909 Halls Ferry Road, Vicksburg, MS 39180-6199; Department of Biology, University of Dayton, Dayton, OH 45469; Department of Ocean Sciences, Louisiana State University, Baton Rouge, LA 70803			8. PERFORMING ORGANIZATION REPORT NUMBER Technical Report EL-94-1	
9. SPONSORING/MONITORING AGENCY NAME(S) AND ADDRESS(ES) U.S. Army Engineer District, Honolulu, Fort Shafter, HI 96858; U.S. Environmental Protection Agency, Region IX, San Francisco, CA 94105			10. SPONSORING/MONITORING AGENCY REPORT NUMBER	
11. SUPPLEMENTARY NOTES Available from National Technical Information Service, 5285 Port Royal Road, Springfield, VA 22161.				
12a. DISTRIBUTION/AVAILABILITY STATEMENT Approved for public release; distribution is unlimited.			12b. DISTRIBUTION CODE	
13. ABSTRACT (Maximum 200 words) This report provides details for the construction of a hot-bead thermistor current meter which is capable of measuring water velocities on a millimeter spatial scale and for the construction of a compact and accurate calibration system. Hot-bead thermistor current meters can be built with response times of 200 ms capable of measuring velocities between 0.1 and 80 cm s <sup>-1</sup> . The construction of a sturdy probe for application in lotic systems such as high gradient Hawaiian streams was achieved by the use of heavy-duty acrylic tubing, small stainless steel gas-chromatography tubing, and flexible Tygon spaghetti tubing. An acrylic handle anchors the electrical cable at one end and the thermistors at the other. The following criteria were central to the development of the calibration system: (a) accurate calibration; (b) compact unit for storage and use in limited laboratory space; (c) leak-proof system; (d) inexpensive design requirement for readily available materials; and (e) construction requirements for the use of hand tools. The thermistor current meter has been used to measure velocities in the water column and around various substrate features in riverine habitats. More detailed spatial velocity measurements were made in streams by dividing a habitat into small grid cells. With fine spatial scales (e.g., grid sizes of 200 to 300 cm <sup>2</sup> or less) and repetitive sampling under varying water flow conditions, insights into relationships between various spatial and temporal characteristics of microhabitat velocities were made. The current meter has been used to determine ambient velocity profiles around a variety of benthic stream organisms including gobiid fishes, (Continued)				
14. SUBJECT TERMS Current meter                      Stream ecology Goby                                      Stream hydrology Hawaii                                      Thermistor			15. NUMBER OF PAGES 33	
			16. PRICE CODE	
17. SECURITY CLASSIFICATION OF REPORT UNCLASSIFIED	18. SECURITY CLASSIFICATION OF THIS PAGE UNCLASSIFIED	19. SECURITY CLASSIFICATION OF ABSTRACT	20. LIMITATION OF ABSTRACT	

**13. (Concluded).**

atyid shrimp, neritid snails, larval chironomids, and larvae caddisflies. These data can provide insights into the distribution, abundance, feeding patterns, reproduction, and behavior of the organism. Additionally, these data can be used to determine the spatial and temporal relationships between benthic velocities encountered by an organism in its daily life and velocities elsewhere in the water column.

The current meter/probe can provide much needed data on (a) quantification of spatial variation in velocity regimes in both lotic and lentic habitats—these types of data can provide insights into the dynamics of water movement on a fine scale; (b) temporal variation in velocities within a microhabitat; (c) the effects of short- and long-term disturbance events on velocities in a microhabitat; (d) quantification of the velocities encountered by an animal or plant through space and time; and (e) an understanding of the relationship between gross macrohabitat velocities and velocities encountered on a microscale by an organism. These data can provide information on the distribution, abundance, ecology, and behavior of important lotic and lentic organisms and provide the basis for decisions on the management of water flows in critical habitats.