

DETERMINATION OF COMPOSITION AND FLUIDITY OF AN ALLOY FOR IMPREGNATING HARD ALLOYS ON THE BASIS OF TITANIUM CARBIDE

Received – Prispjelo: 2015-08-19
Accepted – Prihvaćeno: 2016-01-20
Preliminary Note – Prethodno priopćenje

In this paper optimum compositions of a metal bond of Cr – Ni - Co system are determined by mathematical planning methods. As a response function, value of bending strength at a temperature of 800 °C was used. On the basis of the developed planning matrix samples of required composition were made, bending strength and long-term strength are measured. A certain composition of alloy-bond and its quantity is found. Spiral tests were conducted to determine fluidity.

Key words: Cr – Ni - Co alloy, titanium carbide, mathematical planning, bending strength, fluidity

INTRODUCTION

Ceramic-metal materials - cermets - prepared by pressing and sintering mixtures of ceramic powders (high-melting point carbides, oxides, silicates and ets.) and metal powders. Carbide powder (oxide, silicate) is mixed with powdered cobalt or other metal, performing the role of binder and sintered at a temperature 1 400-1 5000 °C. During sintering of the bunch dissolves carbides and melts. The result is a dense material (porosity less than 2 %), the structure of which 80-95 % consists of carbide particles connected by the binder. Increasing the binder content causes a decrease in hardness, but leads to increased strength and toughness.

In connection with the search for new high-temperature materials began to appear studies on the effect of the type and amount of binder on the properties of materials, particularly on creep characteristics and yield long-term strength.

It is known that the products on the basis of titanium carbide obtained by standard methods of powder metallurgy have high hardness and wear resistance, but at the same time differ in sufficient low impact hardness, plasticity and high fragility.

It complicates possibility of their processing and limits application both at room temperatures, and at elevated ones.

In the paper [1] it is shown that the use of impregnation method in the process of cermet manufacturing makes it possible to considerably improve their operational properties.

When using this method the metallic phase as a bond is added not as a powder form, but as a liquid-alloy entered by impregnating. The method of impregnation enables to obtain low-porous products of the necessary form with the minimum deviations from given sizes; in many respects these products remind exact molding. It should be noted that when changing a bond composition, the opportunity occurs to give cermets certain properties.

In this paper it studied the effect of the content of the nickel-chromium and nickel-cobalt-chromium binder on the properties of the cermet based on titanium carbide. Thus binder content was varied depending on the desired properties of the product. For example, if the material should have high tear resistance, and demands for impact resistance are relatively less important (e.g., when used in turbine disks small), it is desirable to use materials having from about 20 to 45 % (by weight) of the binder alloy. However, if we consider materials for the guide vanes of turbines, where a somewhat lower creep rupture strength, but increased toughness, can prevent the use of material containing from 50 to 65 % (by weight) of binder.

In the earlier conducted studies [2,3] it was established that using Cr – Ni - Co system alloys as a bond, it is possible to give products from titanium carbide certain heat resisting properties.

The purpose of the present paper was establishing optimum composition of a metal bond on the basis of Cr – Ni - Co system with the use of mathematical planning methods and studying fluidity of some alloys of this system.

EXPERIMENTAL AND DISCUSSION

Let's consider the mathematical description of the system [4]: TiC, Ni, Cr (with = 100 (Ni + Cr), number

A. Z. Issagulov, Sv. S. Kvon, V. Yu. Kulikov, T. S. Filippova, G. K. Koshebayeva, I. I. Yerakhtina, Karaganda State Technical University, Karaganda, Kazakhstan

of a bond. As basic data the content of TiC, Ni, Cr and number of a bond in % are accepted. Basic data are taken on the basis of earlier conducted studies [2]. As a response function, values of bending strength, MPa at a temperature of 800 ° C are used Table 1.

Table 1 Values of factor levels and variability steps

Factor	Base level	Variability step
X ₁	50	10
X ₂	40	12
X ₃	10	3
X ₄	50	10

Were:

- X₁ - factor defining the content TiC / %;
- X₂ - factor defining the content Ni / %;
- X₃ - factor defining the content Cr / %;
- X₄ - factor defining the content bond / %.

The mathematical description of the studied alloy can be presented as the regression equations:

$$y = a_0 + a_1X_1 + a_2X_2 + a_3X_3 + a_4X_4$$

Were:

- a₀, a₁, a₂, a₃, a₄ – corresponding regression coefficients.

After conducted calculations the following regression equation was obtained:

$$y = 1564,25 + 19,25 X_1 + 37,75 X_2 + 2,75 X_3 + 104,25 X_4 \tag{1}$$

The predictive Fisher’s ratio test is defined by the relation of the variance estimates:

$$F_p = \frac{\max(s_{(AD)}^2, s_y^2)}{\max(s_{(AD)}^2, s_y^2)} = \frac{24934,7}{2261,5} = 11$$

where s_(AD)² – dispersion of standard deviation; s_y² – standard deviation.

The calculated value of Fisher’s ratio test F_p < F_{tab} = 19,3 for mentioned degrees of freedom, thus far, the equation is (1) adequate.

On the basis of the equation (1) bend strengths were calculated, as a response function. The alloys that have the highest values of a response function (see Table 2), were used as samples for experimental studies.

Table 2 Compositions of alloys calculated on the basis of the regression equations and planning matrix

Sample	Chemical composition / %			
	TiC	bond		
		Ni	Co	Cr
Sample 4/1	70	12	18	7
Sample 5/1	60	24	9	7
Sample 6/1	50	28	12	10
Sample 7/1	40	40	7	13

In the considered alloys the content of the bond in weight changed from 30 % to 60 %.

Laboratory samples were put on trial for bending strength at a temperature of 800 ° C. Tests were carried out on test methods for hard alloys [4]. Results on deter-

mination of bending strength of the studied samples are given in Table 3.

Figure 1 shows dependences (calculated on the basis of the regression equations and experimental) of bending strength from the content of the bond. As Figure 1 shows, calculated and experimental data are in sufficient good correlation, especially in the range of 40 – 50 % of the content of the bond.

Table 3 Mechanical properties of the studied samples

Sample	Bond content / %	Bending strength	100 hour long-term strength / MPa	
		R _B / MPa	800 °	1 000 °
Sample 4/1	30	1 200-1 300	120	-
Sample 5/1	40	1 340-1 500	320	80
Sample 6/1	50	1 590-1 790	280	60
Sample 7/1	60	1 740-1 880	260	60

The conducted studies showed that the highest values of bending strength and, respectively, sample 5/1 containing 40 % of the bond have values of long-term strength. The bond composition: 24 % of Ni; 9 % of Co; 7 % of Cr.

Introduction of the metallic bond to products of powder metallurgy by method of impregnation assumes sufficiently high foundry properties of liquid-alloy, in particular, fluidity.

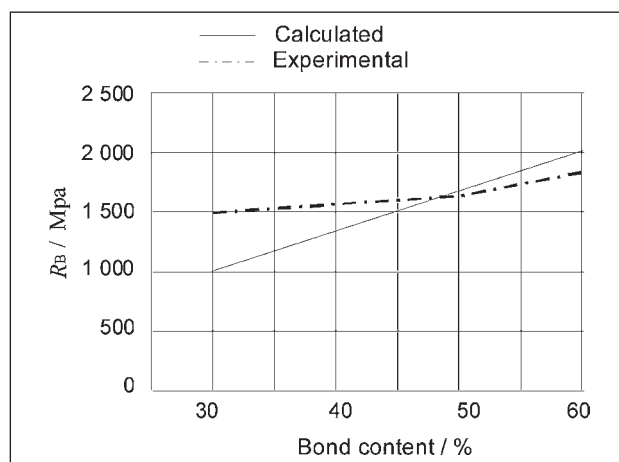

Figure 1 Calculated and experimental values of bending strength depending on the bond content

Fluidity - the ability of metals and alloys in a molten state to fill the cavity of the standard form (sample), and accurately reproduce the outline of the casting. Fluidity depends upon: a) with the composition and physico-chemical properties of the alloy; b) the thermal properties of the form; c) molding process conditions. Pure metals and eutectic alloys have the greatest fluidity. The alloys based on solid solutions or heterogeneous structures is a solid solution with the particles are distributed in other phases have a lower fluidity. This is due to the different nature of the solidification process caused by wide temperature range of crystallization: the difference between the temperature of the beginning of (liq-

uidus) and end (the solidus) for the crystallization of a particular alloy. Fluidity determined by a standard sample in the form of a channel of defined length and diameter of the sprue cup.

In this paper fluidity of alloys was estimated by pouring-in of special technological samples. In this investigation a spiral test [6,7] was used. According to this method fluidity of alloy is determined by length (in centimeters) of the spiral bar which is formed in the course of liquid-alloy motion in channels of technological samples (Figure 2).

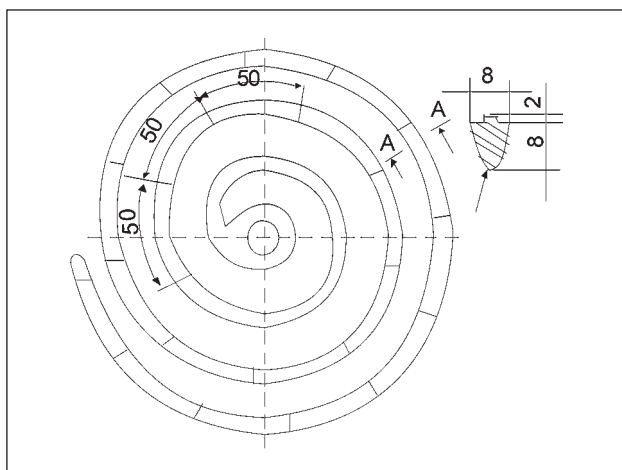

Figure 2 Spiral sample to determine alloy fluidity

Table 4 provides values of fluidity of the used alloys. For comparison data on fluidity of austenitic steel 1X18H9T [7] are provided.

Table 4 Data on fluidity of alloys corresponding to the bond composition

Bond of sample	Fluidity / mm
Sample 4/1	280
Sample 5/1	295
Sample 6/1	330
Sample 7/1	355
Steel 1X18H9T	340

As data of Table 4 show the bond of sample 7/1 has the best fluidity. However, this alloy considerably concedes to alloy 5/1 in heat resisting properties.

CONCLUSION

On the basis of the developed planning matrix and conducted experiments it is found that an optimum alloy for impregnation from the perspective of high temperature strength is an alloy that has composition 24 % Ni; 9 % Co; 7 % Cr when the bond composition is 40 % (sample 5/1).

According to the conducted studies fluidity of an alloy is only 295 mm that is less than fluidity of high-alloyed steel. Therefore satisfactory conducting process of impregnation requires developing a “frame” with certain characteristics (porosity, pore size, etc.). The last ones, in turn, are functions of grading composition and moulding conditions that defines problems of the subsequent studies.

REFERENCE

- [1] Kiparisov S. S. Karbid titana: poluchenie, svoistva, primeneniye. Metallurgy, M. (1997), 216p.
- [2] Kvon Sv.S., Sidorina E.A. i dr. Svoistva materialov na osnove karbida titana, prednaznachennih dlya raboti pri visokoi temperature. Metallurgiya. Mashinostroenie. (2013) 3.
- [3] Y. Lu, Y. Dong, S. Guo. Promising New Class of High-Temperature Alloys: Eutectic High-Entropy Alloys. Scientific Reports 4, Article number: 6200 29, (2014) April.
- [4] Ermakov S.M. Matematicheskaya teoriya optimalnogo eksperimenta. Science, M. (2007), 320 p.
- [5] GOST 20019_74. Splavi tverdie spechennye. Metod opredeleniya prochnosti pri izgibe.
- [6] GOST 16438—70. Opredelenie jidkotekuchesti metallicheskikh rasplavov metodom spiralnoi probi.
- [7] Girshovich N.G. Spravochnik po chugunnomu i stalnomu lityu. M. (2007), 345p.

Note: The responsible for England language is Assel Alashpekova, Karaganda Kazakhstan