

Theoretical research into directional stability of trailed tandem- type disk harrow

V. Bulgakov¹, J. Olt^{2,*}, V. Nadykto³, V. Volskiy⁴, S. Polishchuk⁵,
A. Aboltins⁶ and H. Beloev⁷

¹National University of Life and Environmental Sciences of Ukraine, 15 Heroyiv Oborony Str., UA 03041 Kyiv, Ukraine

²Estonian University of Life Sciences, Institute of Technology, 56 Kreutzwaldi Str., EE 51006 Tartu, Estonia

³Dmytro Motorny Tavria State Agrotechnological University, 18^B Khmelnytsky Ave, UA 72310 Melitopol, Zaporozhye Region, Ukraine

⁴National Scientific Centre, Institute for Agricultural Engineering and Electrification, 11 Vokzalna Str., Glevakcha 1, Vasylykiv District, UA 08631 Kyiv Region, Ukraine

⁵National Scientific Centre, Institute of Agriculture of NAAS of Ukraine, 2^b, Mashinobudivnikiv Str., Chabany vil., Kyiv-Svyatoshin Dist., UA 08162, Kyiv Region, Ukraine

⁶Latvia University of Life Sciences and Technologies, Cakstes Blvd. 5, LV 3001 Jelgava, Latvia

⁷University of Ruse “Angel Kanchev”, 5, Studentska Str., BG 7017, Ruse, Bulgaria

*Correspondence: jyri.olt@emu.ee

Received: August 27th, 2021; Accepted: October 6th, 2021; Published: October 7th, 2021

Abstract. Disking is one of the methods of soil cultivation, provides its effective crumbling, loosening, partial mixing and soil inversion. This ensures that crop residues on the soil surface are shredded and intermixing with loosened soil particles. Since, in addition to crop stubble, weeds are also counted as crop residues, soil disking, along with the use of herbicides, is often regarded as the most effective method of controlling the weediness of the agricultural background. Despite the fact that numerous studies on the disk harrow working process are available, insufficient attention has been paid to the study of the stability of harrow machine-tractor units, especially trailed ones. The purpose of this study is to establish the theoretical patterns that would provide for selecting the trailed disk harrow parameters that ensure the desired directional stability of the implement, which, in its turn, helps to achieve the desired qualitative performance of the disk harrowing machine-tractor unit. The principles of the theory agricultural machine, analytical mechanics, higher mathematics, as well as methods of PC-assisted numerical calculations have been used. According to the results of the study, it has been established that sufficient directional stability of the trailed disk harrow can be ensured if its working width B , the distance from the hitch point to the centre of resistance (parameter d) and the operating speed V_0 are properly selected. Determining the above-mentioned parameters of the disk harrow with the use of the obtained new analytical relations ensures achieving just their optimal combination, which provides for the maximum field productivity of the harrow machine-tractor unit with the satisfactory stability of disk harrow movement in the horizontal plane.

Key words: disk harrow, dissipation; quasi-elasticity, speed, stability, working width.

INTRODUCTION

One of the methods of soil cultivation, providing good crumbling, loosening, partial mixing and soil inversion, is disking operation. If there are plant residues on the soil surface, they are effectively shredded and involved in the process of intermixing with loosened soil particles. Since, in addition to crop stubble, crop residues include weeds, soil disking, along with the use of herbicides, is often seen as a method of controlling the weediness of agricultural background (Knezevic et al., 2003; Balsari et al., 2021).

Soil disking, as is known, is performed by trailed or mounted (sometimes semi-mounted) disk harrows. Scientists all over the world pay a lot of attention to the rational choice of their design parameters. After careful analysis, the bulk of the results obtained in the completed research can be divided into two groups.

The first and more numerous of them are studies of the influence of the design parameters and operating mode of the disk harrow on the draft-energy performance of the tillage unit.

Ranjbar et al. (2013) studied the effect of disk harrow speed on its draft resistance. The speed of the tillage unit varied from 0.80 to 1.98 m s⁻¹. In addition, soil moisture (11–23%) and tillage depth (4–16 cm) were variables.

The same goal was pursued by Kogut et al. (2016). The researchers changed the angle of the harrow discs in the horizontal (12–20°) and vertical (7–15°) planes at different values of tillage depth and working speed of the tillage unit.

The influence of the disk harrow tool setting angle in the horizontal plane (when installed up to 30°), the operating speed (2.1–3.1 m s⁻¹) and the disk depth (6–18 cm) on the disk draft resistance was studied by Bulgakov et al. (2019).

In a study by Priporov & Priporov (2021) when measuring the draft resistance of harrows, the authors determined the specific value of this parameter per meter of the working width of the tillage tool. Similar results were obtained by Serrano et al. (2008) and Serrano & Peça, 2008. The working width of the disk harrow did not exceed 4 m, and its operating speed started from a rather small value - 0.8 m s⁻¹.

In addition to estimating the draft resistance of the disk harrow, researchers have studied the effect of changes in its parameters and mode of operation on the fuel consumption of the wheeled tractor used and the slipping of its wheels (Serrano et al., 2003 and 2007; Salokhe et al., 2010).

In addition to the traditional arrangement of the disk harrow, variants of combining different working tools in one design have been investigated. For example, in Javadi & Hahiahmad (2006) the option of combining disks with rollers was considered. There have been studies of harrow designs, in which the front row of the tools has an active drive and the rear row has a passive drive (Upadhyay & Raheman, 2018). The disk harrow parameters studied were the angles of inclination of the tools in the horizontal plane, as well as the depth of tillage and soil hardness (cone index). The presence of actively driven disks in some harrow designs made it necessary to study the effect of the mode of their rotation on the draft resistance of the harrow, as well as the torque and power required to drive these working tools.

In addition to harrows, the use of spherical working tools was investigated in disk ploughs (Ranjbarian et al., 2017). The tillage depth did not exceed 23 cm, and the movement speed of the ploughing unit was, in our opinion, extremely low: 0.5–1.1 m s⁻¹.

The second direction of research on disk harrows is devoted to the study of the influence of the design parameters and operating modes of these implements on the quality of tillage. In the work (Damauskas et al., 2019) the process of quality of chopping and incorporation winter rape stubble into the soil was investigated. The studied parameters were disk setting angles in horizontal plane (10–20°), tillage depth (5–8 cm) and working speed of the harrow (1.4–3.6 m s⁻¹). The results of almost similar research problem were presented in the article (Aykas et al., 2005).

The positioning of disk working tools on the harrow frame provides for their movement in the soil with a certain overlap. The value of this parameter in relation to the angles of inclination of the disk tool in the horizontal and vertical projection planes is analysed in the work (Zhuk & Sokht, 2018).

From the above analysis, it is easy to see that among the numerous scientific studies devoted to disk implements, there are almost no works aimed at substantiating the optimal value of their working width (parameter *B*). Especially in combination with the establishing the optimal relation between this design parameter and the desired value of the working speed of the disking machine-tractor unit (parameter *V*). While that is very important, because the right combination of parameters *B* and *V* allows you to achieve optimum field productivity of the tillage machine (*W*).

The attempt to increase the *W* value by increasing the value of the *B* parameter encourages engineers to create trailed machines. And it is quite logical, because an increase in the working width of any agricultural machine is associated with a corresponding increase in its weight. And the greater the value of the latter is, the more problematic it is to use such a machine in the tractor-mounted configuration.

It should be emphasized that the use of wide-span trailed agricultural machines requires a careful study of their stability in the horizontal plane (Bulgakov et al., 2016, 2017), especially at relatively high (more than 2.5 m s⁻¹) speeds of the machine-tractor unit.

The problem is that the increase in the linear dimensions and the resulting increase in the masses, moments of inertia of trailed machines together with the increase in working speeds of their movement leads to a significant change in the dynamic properties of the entire machine-tractor unit. In some cases, the latter can acquire the properties of a mechanical oscillating system with reduced directional stability. As a result, this definitely leads to a decrease in the quality of the technological operation performed by this machine-tractor unit. When disking the soil, this can manifest itself in the presence of blunders in the field, increased overlap of the cultivated area, undesirable type of the course stability of the used aggregate tractor and the associated increased fuel consumption, etc.

Once again emphasizing and understanding the importance of this problem, the authors, however, could not find the scientific research results related to the study of the stability of harrow machine-tractor units, first of all, trailed ones.

In view of the above, the purpose of this study is to establish theoretical patterns that allow to select the values of speed and working width of the trailed disk harrow that ensure its desired directional stability. The solution of such a problem is one of the main

conditions ensuring the high-quality performance of the technological process carried out by the machine.

MATERIALS AND METHODS

Initially, the assumption is made that the trailed tandem type (with an X frame) disk harrow as a dynamic system performs plane-parallel motion only in the horizontal plane. For analytical study of the trailed disk harrow movement, it is necessary to generate the differential equation of its movement relative to the point of its attachment to the carrying tractor. Fig 1 shows the equivalent diagram of such disk harrow movement, considering the movement of all its points in the horizontal plane. In this case, in first approximation, it is assumed that the point of connection of the disk harrow to the wheeled tractor (point S), with which the movable reference system YOX , is connected, moves linearly and uniformly at speed \vec{V}_o , the modulus of which is $V_o = \text{const}$ (Fig. 1).

All external forces acting on a given dynamic system are represented by the resultant vector \vec{R} . It is applied at the centre of resistance of the harrow, i.e., at point K (Fig. 1) and determines the direction of the absolute velocity \vec{V}_a of this point.

In the vector representation \vec{V}_a is the geometric sum of the translational \vec{V}_o and relative \vec{V}_r speeds of the disk harrow resistance centre movement. The modulus of the latter is equal to:

$$V_r = \dot{\varphi} \cdot d, \quad (1)$$

where d – the distance between the disk harrow's hitching point (point S , Fig. 1) and the centre of its resistance (point K).

The result of the relative movement of the point K is the horizontal rotation of the harrow relative to the point of its attachment to the aggregating tractor. A quantitative measure of this rotation is the angle φ (Fig. 1).

As follows from the analysis of Fig. 1, the vector of absolute speed of the disk harrow's centre of resistance \vec{V}_a makes an angle δ with its trailing device (line SK). It is easy to see that, given the smallness of the angles φ and δ and using expression (1), the value of $\tan \delta$ will be equal to:

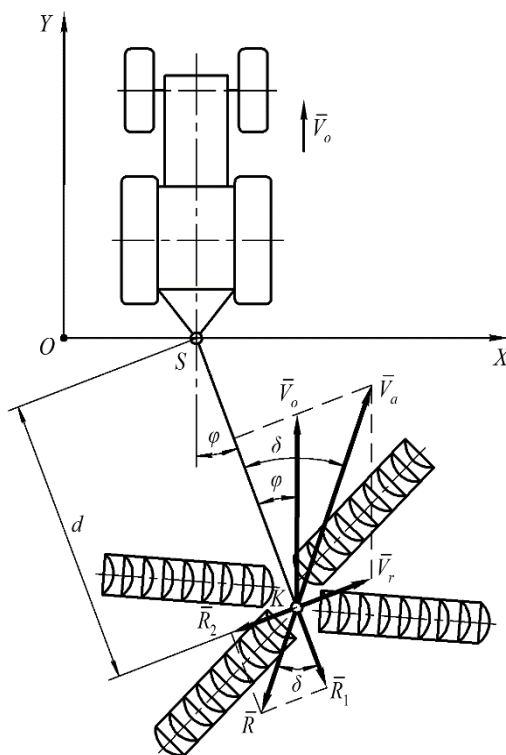

Figure 1. Equivalent diagram movement performed by trailed tandem type disk harrow in the horizontal plane.

$$\tan \delta \approx \delta \approx \frac{V_r + V_o \cdot \sin \varphi}{V_o \cdot \cos \varphi} = \frac{\dot{\varphi} \cdot d + V_o \cdot \varphi}{V_o} = \frac{\dot{\varphi} \cdot d}{V_o} + \varphi. \quad (2)$$

The resultant force vector \bar{R} (Fig. 1) is conveniently represented as the geometrical sum of two components: longitudinal \bar{R}_1 and transverse \bar{R}_2 . The first can be expressed by the following composition:

$$R_1 = K_s \cdot B, \quad (3)$$

where K_s – specific draft resistance of the harrow, kN m^{-1} ; B – disk harrow working width, m.

As for the force \bar{R}_2 , it can be determined from the following relation (Fig. 1):

$$R_2 = R_1 \cdot \tan \delta. \quad (4)$$

Taking into account relations (2), (3) and (4), we finally have:

$$R_2 = K_s \cdot B \cdot \left(\frac{\dot{\varphi} \cdot d}{V_o} + \varphi \right). \quad (5)$$

The differential equation that describes the independent rotational motion of the disk harrow relative to the point S of its attachment to the aggregating tractor is:

$$J_o \cdot \ddot{\varphi} = \Sigma \bar{M}_{(S)}, \quad (6)$$

where J_o – moment of inertia of the disk harrow relative to the vertical axis passing through the point S ; $\Sigma \bar{M}_{(S)}$ – sum of moments of external forces acting on the harrow relative to the point S .

As follows from the equivalent diagram shown in Fig. 1:

$$\Sigma \bar{M}_{(S)} = -R_2 \cdot d, \quad (7)$$

or taking into account relation (4):

$$\Sigma \bar{M}_{(S)} = -K_s \cdot B \cdot d \cdot \left(\frac{\dot{\varphi} \cdot d}{V_o} + \varphi \right). \quad (8)$$

The value of the moment of inertia J_o can be calculated with sufficient accuracy from the following relationship:

$$J_o = \frac{m}{3} \cdot (13d^2 + 4b^2 + a^2), \quad (9)$$

where m, b, a – mass (kg), length (m) and width (m) of one section of the disk harrow, respectively.

After substituting the obtained expressions (8) and (9) into (6) and performing appropriate transformations, we finally obtain the differential equation of motion, i.e. the mathematical model of the trailed disk harrow rotary motion, in the following form:

$$\ddot{\varphi} + 2n \cdot \dot{\varphi} + k^2 \cdot \varphi = 0, \quad (10)$$

where $n = \frac{K_s \cdot B \cdot d^2}{2J_o \cdot V_o}$; $k^2 = \frac{K_s \cdot B \cdot d}{J_o}$.

It should be noted that the coefficient n characterizes the dissipative properties of the dynamic system and the coefficient k^2 – characterizes the quasi-elastic ones. Since the values of these coefficients are always positive, the oscillatory motion of the trailed harrow, as a dynamic system, is stable. However, this stability can be various. First of

all, it depends on the roots of the characteristic Eq. (10). In this case there can be three variants of them. Namely:

$$\lambda_{1,2} = -n \pm i\sqrt{n^2 - k^2} : \text{if } n^2 < k^2; \quad (11)$$

$$\lambda_{1,2} = -n \pm \sqrt{n^2 - k^2} : \text{if } n^2 > k^2; \quad (12)$$

$$\lambda_{1,2} = -n : \text{if } n^2 = k^2, \quad (13)$$

where $i = \sqrt{-1}$.

Let us consider these three cases one by one. Due to the presence of the complex component, the solution of relation (11) represents a stable (i.e., damped), but still oscillatory motion of the trailed harrow relative to its equilibrium position.

The roots defined by expressions (12) and (13) belong to the solution of Eq. (10) in this form:

$$\varphi = e^{-nt} \cdot (K_1 \cdot e^{\sqrt{n^2 - k^2} \cdot t} + K_2 \cdot e^{-\sqrt{n^2 - k^2} \cdot t}), \quad (14)$$

where K_1, K_2 – integration constants; t – time.

From the analysis of Eq. (14), it follows that at time $t = 0$ some initial angle φ_0 of disk harrow's deviation from the equilibrium state is related to the integration constants K_1 and K_2 in accordance with the following expression:

$$\varphi = \varphi_0 = K_1 + K_2. \quad (15)$$

At the same moment of time (i.e., at $t = 0$) another relation is also true:

$$\dot{\varphi} = K_1 \cdot (\sqrt{n^2 - k^2} - n) - K_2 \cdot (\sqrt{n^2 - k^2} + n) = 0. \quad (16)$$

The joint solution of equations (15) and (16) allows us to determine the integration constants:

$$K_1 = \varphi_0 \cdot \frac{\sqrt{n^2 - k^2} + n}{2 \cdot \sqrt{n^2 - k^2}}; \quad K_2 = \varphi_0 \cdot \frac{\sqrt{n^2 - k^2} - n}{2 \cdot \sqrt{n^2 - k^2}}.$$

After substituting these constants into Eq. (14), we obtain the solution to the mathematical model (10) in the following form:

$$\varphi = \frac{\varphi_0}{2 \cdot A} \cdot e^{-nt} \cdot [(A + n) \cdot e^{At} + (A - n) \cdot e^{-At}], \quad (17)$$

where $A = \sqrt{n^2 - k^2}$.

Relation (17) describes the damped aperiodic motion of the considered dynamic system. Obviously, it is more preferable, than the oscillatory motion.

The roots defined by expression (12) of Eq. (17) will occur if the following condition is met:

$$n^2 = \frac{(K_s \cdot B)^2 \cdot d^4}{4J_o^2 \cdot V_o^2} \geq k^2 = \frac{K_s \cdot B \cdot d}{J_o}. \quad (18)$$

From the analysis of the obtained expression (18), it follows that the movement speed V_o of the disk harrow tilling unit should not exceed the value determined by this expression:

$$V_o \leq \frac{d}{2} \cdot \sqrt{\frac{3K_s \cdot B \cdot d}{m \cdot (13d^2 + 4b^2 + a^2)}}. \quad (19)$$

The obtained Eq. (19), as we see, includes such an important construction parameter of the disk harrow as its working width B . In this case, in conjunction with the speed V_o of working movement, it also determines such an indicator as the field productivity W of this tillage machine. In analytical form it looks as follows (Boson et al., 2019):

$$W = 0.36 \cdot B \cdot V_o. \quad (20)$$

The optimal value of the disk harrow working width B can be determined by taking into account the following relation of partial derivatives:

$$\frac{\partial W}{\partial V_o} = \frac{\partial W}{\partial B}, \quad (21)$$

where N_e – engine power of the used aggregating tractor, kW.

It is known from tractor theory (Macmillan, 2002) that:

$$N_e = \frac{(K_s \cdot B + f \cdot G) \cdot V_o}{\eta_t \cdot (1 - \delta)}, \quad (22)$$

where f – rolling resistance coefficient; G , η_t , δ – operating gravity force (kN), transmission efficiency and drive wheel slip of the used wheeled tractor, respectively.

According to the up-to-date approaches to the determination of the value of the parameter δ (Nadykto et al., 2015), we take the linear pattern of its change in the following form is assumed:

$$\delta = k + k_1 \cdot \frac{K_s \cdot B}{G}, \quad (23)$$

where k , k_1 – approximation constants of relation of slipping of the tractor wheels and the draft force generated by the tractor.

Taking into account expression (23), relation (22) has the following form:

$$N_e = \frac{(K_s \cdot B + f \cdot G) \cdot V_o \cdot G}{\eta_t \cdot [G(1 - k) - k_1 \cdot K_s \cdot B]}. \quad (24)$$

After determining the partial derivatives $\frac{\partial W}{\partial V_o}$, $\frac{\partial W}{\partial B}$, $\frac{\partial N_e}{\partial V_o}$, $\frac{\partial N_e}{\partial B}$, then substituting these expressions into (21) and performing appropriate transformations, we obtain a relationship that allows us to determine the optimal working width B of the disk harrow. We have:

$$C_3 \cdot B^3 + C_2 \cdot B^2 + C_1 \cdot B + C = 0, \quad (25)$$

where $C_3 = K_s^3 \cdot k_1^2 \cdot G$;

$$C_2 = -(K_s \cdot G)^2 \cdot (1 - k);$$

$$C_1 = -K_s \cdot k_1 \cdot f \cdot G^3 \cdot (1 - k);$$

$$C = G^4 \cdot f \cdot (1 - k)^2.$$

Thus, all the analytical expressions determine the relations between the parameters of the considered dynamic system have been obtained. The application of these expressions make it possible in practice to determine the optimal values of the said parameters.

As an example of applying the obtained theoretical results, let us consider a machine-tractor unit for soil disking on the basis of the aggregating wheeled tractor of class 3 with a nominal drawbar pull of 30 kN. Such tractor with 4WD wheel arrangement and 23.1R26 tires has the following parameters: operational gravity $G = 81$ kN; engine

power $N_e = 135$ kW; transmission efficiency $\eta_{tr} = 0.93$; approximation constants of tractor wheels slipping vs. drawbar pull $k = 0.001$ and $k_1 = 0.450$.

The disk harrow considered in the theoretical studies has the following values of its design parameters: $m = 850$ kg; $d = 4.8$ m; $a = 2.2$ m; $b = 0.8$ m. These design parameters are averaged for the family of those trailed disk harrows that in practice are used with the aforementioned tractor with a nominal drawbar pull of 30 kN.

Many years of practice have shown that the disking machine-tractor unit is most often used on agricultural background, for which the average value of the coefficient of to rolling resistance is $f = 0.12$. In this case, the specific resistance coefficient of disk harrow K_s can vary within range of 5.5-7.0 kN m^{-1} . In principle, this corresponds to the experimental data presented in (Serrano & Peça, 2008).

Numerical solution of received analytical expressions (17), (18), (19) and (25) has been carried out with the use of the PC program developed by authors. This made it possible to plot the graphical relations between the parameters of the considered dynamic system, as presented in Fig. 2 – Fig. 7.

In the theoretical calculations of the relation (17), the initial deviation of the trailed harrow from the state of equilibrium was taken equal to $\varphi_0 = 3^\circ$. As is known from practice, in the real conditions of operating this tillage tool, the value of this angle does not exceed 5° .

RESULTS AND DISCUSSION

The analysis of solution of equations (18) and (22) shows that with increase of K_s from 5.5 to 7.0 kN m^{-1} the optimal value of disk harrow working width B decreases (Fig. 2).

But the change in the parameter B occurs in such a way that the value of the product ($B \cdot K_s$), which is the draft resistance of the disc harrow, remains almost at the same level. In this connection, the operating speed V_o of forward movement of the disk tillage machine, which satisfies the condition (19), is also constant and equal to 2.86 m s^{-1} (i. e. 10.3 km h^{-1}). The required tractor engine power is 132 kW. This is quite realizable, because the nominal power of the tractor engine with a nominal drawbar pull of 30 kN can, as noted above, be 135.0 kW.

Increasing the speed V_o of the working movement of the tractor with disk harrow to a level of more than 2.86 m s^{-1} is technically possible, due to the consequent change in the value of the condition (18), the very nature of the relative motion performed by the trailed tillage implement under consideration as a dynamic system will change (Fig. 3).

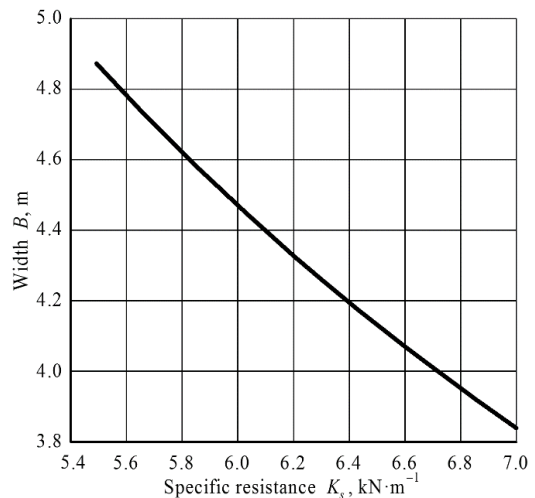

Figure 2. Relation of the working width B of the disc harrow on the value of K_s .

For example, condition (18) is fulfilled at speed equal to $V_0 = 2.86 \text{ m s}^{-1}$. Since in this case dissipative properties of the dynamic system, represented by the parameter n^2 , prevail over quasi-elastic ones, then after the initial deviation of the harrow from the equilibrium state by 3° its aperiodic movement back to the initial position takes place.

After increasing the working speed of the tillage machine up to $V_0 = 3.36 \text{ m s}^{-1}$ condition (18) is violated. This means that the quasi-elastic properties of the system, represented by the coefficient k^2 , become predominant in the considered dynamic system. As a result, the movement of the trailed disk harrow in relation to the point S (Fig. 1) becomes oscillatory. The higher the working speed of the cultivation unit (Fig. 3) is, the more these oscillations occur.

Analysis of equations (18) and (19) shows that the nature of the relative motion of the disc harrow is influenced to some extent, in addition to its working width B , by the moment of inertia J_o . The latter, as can be seen from expression (9), in its turn depends on such parameters as d , m , b and a . Of these, according to the results of our calculations, the first two (i.e., d and m) have a significant influence on the value of J_o . In this case, the influence of the parameter d is more tangible if changes in the mass of the harrow are considered within such limits, which do not lead to changes in its working width B .

It should be noted that the trailed disk harrow in terms of mechanics is essentially a physical pendulum, the swing radius of which represented by the parameter d – the distance between the hitch point of the disk harrow (point S , Fig. 1) and the centre of its resistance (point K). As the value of this parameter d decreases, the character of the relative motion of the disk harrow trends to change from asymptotically stable to oscillatory one (Fig. 4).

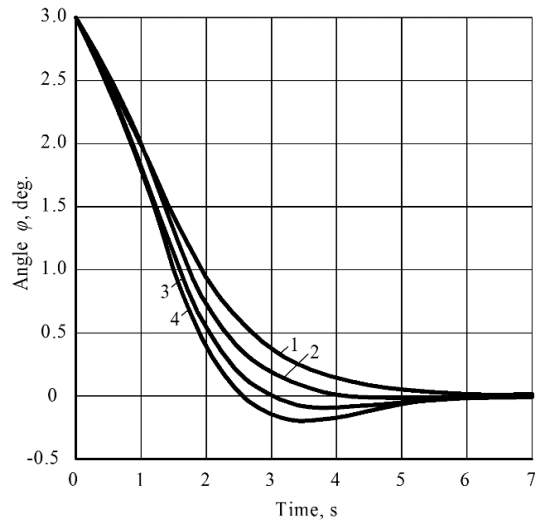

Figure 3. Dynamics of change in the disk harrow deviation angle φ at different forward speeds V_0 : 1 – $V_0 = 2.86 \text{ m s}^{-1}$; 2 – $V_0 = 3.36 \text{ m s}^{-1}$; 3 – $V_0 = 3.86 \text{ m s}^{-1}$; 4 – $V_0 = 4.36 \text{ m s}^{-1}$.

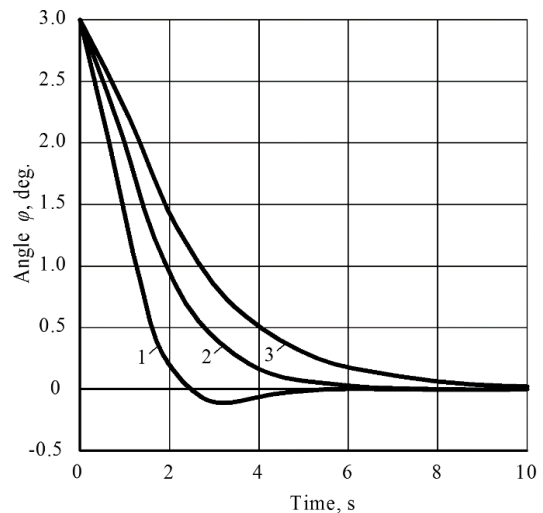

Figure 4. Dynamics of change in disk harrow deviation angle φ at different values of the parameter d : 1 – $d = 2.8 \text{ m}$; 2 – $d = 4.8 \text{ m}$; 3 – $d = 6.8 \text{ m}$.

This result is quite logical. As noted above, increasing the value of the parameter d leads to an increase in the moment of inertia of the disk harrow J_o . However, at first glance, it would seem that according to Eq. (18), this should cause a corresponding decrease in the values of the parameters n^2 and k^2 .

In reality, this is true only for the quasi-elastic coefficient (i.e. k^2). For it, an increase in the parameter d leads to such an outstripping growth of the moment of inertia J_o , which eventually causes an intensive decrease in the value of the k^2 (Fig. 5).

The nature of the change in the square of the dissipative parameter n^2 in this case is quite different. Here, a similar increase in the value of the design parameter d , raised to the fourth degree [see expression (18)], significantly outpaces the growth of the value of the moment of inertia of the harrow J_o . As a result, as the value of d increases, the value of the parameter n^2 also increases accordingly (Fig. 5). Because of the predominance of dissipative (i.e., scattering) properties in the dynamical system we are considering, it becomes more prone to asymptotic motion after receiving an external deflecting perturbation.

Conversely, reducing the distance between the hitch point and the centre of resistance of the disk harrow (parameter d) can result in, as shown in Fig. 4, although stable, but still oscillatory nature of its relative motion in the horizontal plane of projections.

The limit value for the reduction of the parameter d can be easily determined by using the characteristic point M_1 (Fig. 5). Its coordinates correspond to the conditions movement of the trailed disk harrow, in which the condition $n^2 = k^2$ is true. In this case solving the Eq. (10) results in obtaining the roots defined by expression (13).

In fact, the abscissa of the point M_1 reflects the value of the design parameter d , the decrease of which can cause the oscillatory behaviour of the trailed disk harrow, when it returns from the perturbed state to the position of stable equilibrium.

However, it this does not imply that in the real design of this tilling implement, the link length SK (Fig. 1) should be as long as possible. It should be remembered that an increase in the parameter d inevitably leads to an increase in the turning radius of the unit (Bulgakov et al., 2018) and its longitudinal dimension. And this is already an undesirable situation.

Moreover, a significant increase in the value of J_o as a result of increasing the value of the parameter d can lead to a deterioration in the damping conditions of the harrow angular oscillations during its return from the perturbed position to the initial equilibrium one.

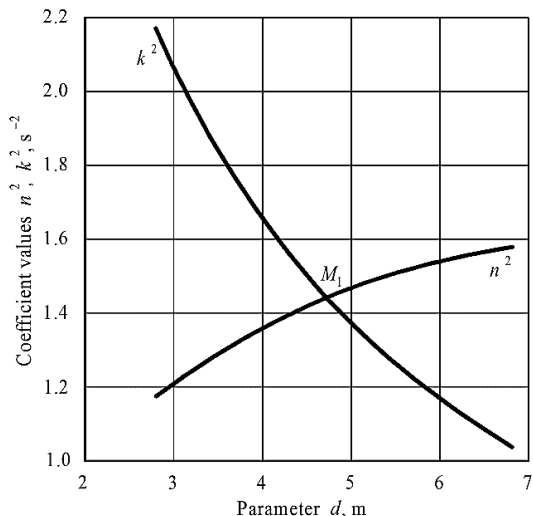

Figure 5. Relation between coefficients n^2 and k^2 and parameter d .

Finding a compromise in this solution lies in selecting the value of d with due account for the condition (19), meeting which ensures the asymptotic character of trailed disk harrow's angular displacement in the horizontal plane.

As emphasized above, increasing the value of the parameter m also affects the moment of inertia of the harrow J_o . However, as calculations show, it's effect is not as significant as that of the parameter d .

The effect of mass m on the coefficients n^2 and k^2 is qualitatively the same, but quantitatively it is different. As calculations show, in the whole range of the accepted values of the parameter m , the dissipative properties of the trailed harrow n^2 decrease more intensively than the quasi-elastic ones k^2 (Fig. 6).

This results in obtaining the characteristic point M_2 , which characterizes the condition $n^2 = k^2$ and separates the zones of asymptotic and oscillatory character of the trailed harrow motion after its return from the deflected state to the initial equilibrium state. It is quite obvious that the first and more preferable of these zones is situated to the left of point M_2 , since in it this zone the dissipative properties of the dynamical system in question prevail over the quasi-elastic ones. That causes the situation, where external disturbances are unable to generate the unwanted oscillatory character of the relative motion of the trailed disk harrow.

As follows from the analysis of the graphical dependences presented in Fig. 6, to ensure the asymptotic character of the perturbed motion of the considered trailed harrow, its design parameter m , defined by abscissa of the point M_2 , should not exceed 880 kg. Otherwise, i.e., when selecting a larger value of mass m , the speed V_o of forward movement of the disk harrow should be reduced. The graphical representation of this process is shown in Fig. 7.

When making the final selection of disk harrow mass, it should be kept in mind that increasing the value of this parameter increases the inertial properties of this dynamic system. In a

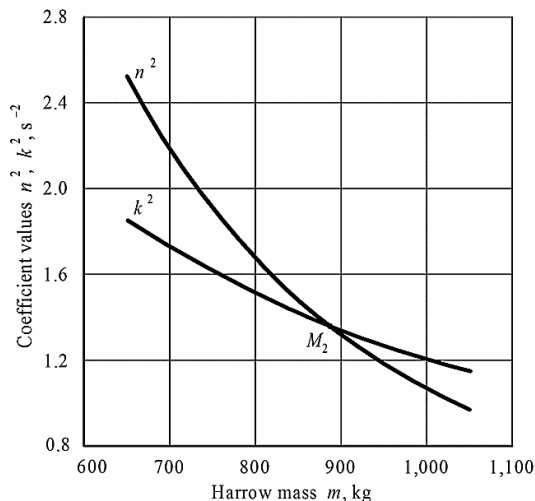

Figure 6. Relation between coefficients n^2 and k^2 and parameter m .

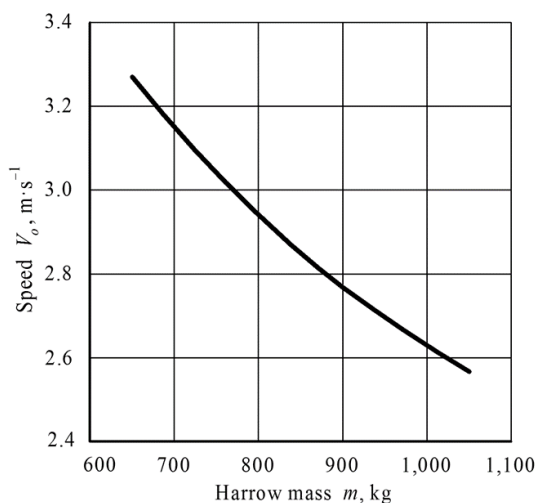

Figure 7. Relation between optimum speed V_o of the disk harrow on its mass.

certain way, this increases its resistance to the influence of external disturbing (deviating) factors. At the same time, a dynamic system with a large mass is much more difficult to bring out of the state of oscillatory motion.

CONCLUSIONS

The satisfactory directional stability of the trailed disk harrow can be ensured by proper selection of its working width B , the distance from the hitch point to the centre of resistance (parameter d) and the operating speed V_0 .

The optimum combination of the disk harrow parameters B , d and V_0 , which provides for the maximum field productivity of the harrow machine-tractor unit with satisfactory stability of the disk harrow movement in the horizontal plane, is achieved, when these parameters are determined using the obtained new analytical relations (18), (19) and (25).

The theoretically obtained mathematical relations (18), (19) and (25) can be used for solving similar problems in case of any other symmetrical machine-tractor unit with a trailed process part.

REFERENCES

- Aykas, E., Cakir, E. & Gulsoylu, E. 2005. The effect of tillage parameters on the performance of the heavyduty offset disk harrow. *Asian J. Plant Sci.* **3**, 425–428.
- Balsari, P., Biglia, A., Comba, L., Sacco, D., Eloi Alcatrão, L., Varani, M., Mattetti, M., Barge, P., Tortia, C., Manzone, M., Gay, P. & Ricauda Aimonino, D. 2021. Performance analysis of a tractor - power harrow system under different working conditions. *Biosystem Engineering* **202**, 28–41. <https://doi.org/10.1016/j.biosystemseng.2020.11.009>
- Boson, E.S., Verniaev, O.V., Smirnov, I.I. & Sultan-Shach, E.G. 2019. *Theory, Construction and Calculation of Agricultural Machines*. 2nd Ed., Scientific Publisher, 810 pp. ISBN: 9789388399838
- Bulgakov, V., Adamchuk, V., Arak, M., Nadykto, V., Kyurchev, V. & Olt, J. 2016. Theory of vertical oscillations and dynamic stability of combined tractor-implement unit. *Agronomy Research* **14**(3), 689–710.
- Bulgakov, V., Adamchuk, V., Nadykto, V., Kistechok, O. & Olt, J. 2017. Theoretical research into the stability of motion of the ploughing tractor-implement unit operating on the 'push-pull' principle. *Agronomy Research* **15**(4), 1517–1529. doi: 10.15159/AR.17.069
- Bulgakov, V., Pascuzzi, S., Ivanovs, S. & Volskyi, V. 2019. Experimental Investigations in Draft Resistance of Spherical Working Tool of Disk Harrow. *Engineering for Rural Development* **18**, 144–152. <https://doi.org/10.22616/ERDev2019.18.N171>
- Bulgakov, V., Pascuzzi, S., Nadykto, V. & Ivanovs, S. 2018. A mathematical model of the plane-parallel movement of an asymmetric machine-and-tractor aggregate. *Agric.* **8**. <https://doi.org/10.3390/agriculture8100151>
- Damanauskas, V., Velykis, A. & Satkus, A. 2019. Efficiency of disc harrow adjustment for stubble tillage quality and fuel consumption. *Soil Tillage Res.* **194**, 104311. <https://doi.org/10.1016/J.STILL.2019.104311>
- Javadi, A. & Hahiahmad, A. 2006. Effect of a New Combined Implement for Reducing Secondary Tillage Operation. *Int. J. Agric. Biol.* **8**, 725–727.
- Knezevic, M., Đurkic, M. & Knezevic, I. 2003. Effects of pre-and post-emergence weed control on weed population and maize yield in different tillage systems. *Plant soil environ* **49**(5), 223–229.

- Kogut, Z., Sergiel, L. & Zurek, G. 2016. The effect of the disc setup angles and working depth on disc harrow working resistance. *Biosyst. Eng.* **151**, 328–337. <https://doi.org/10.1016/j.biosystemseng.2016.10.004>
- Macmillan, R.H. 2002. *The Mechanics of Tractor Implement Performance*. Theory and Worked Examples. University of Melbourne, 165 pp.
- Nadykto, V., Arak, M. & Olt, J. 2015. Theoretical research into the frictional slipping of wheel-type undercarriage taking into account the limitation of their impact on the soil. *Agronomy Research* **13**(1), 148–157.
- Priporov, E.V. & Priporov, I.E. 2021. Justification of parameters of a four-row disk harrow using the experiment planning method. *IOP Conf. Ser. Earth Environ. Sci.* **659**, 8–13. <https://doi.org/10.1088/1755-1315/659/1/012013>
- Ranjbar, I., Rashidi, M., Lehmal, H.F., Mirmoradi, M. & Abdolizadeh, E. 2013. Modeling of double action disc harrow draft force based on tillage depth and forward speed. *Middle East J. Sci. Res.* **17**, 1061–1067.
- Ranjbarian, S., Askari, M. & Jannatkah, J. 2017. Performance of tractor and tillage implements in clay soil. *J. Saudi Soc. Agric. Sci.* **16**, 154–162. <https://doi.org/10.1016/j.jssas.2015.05.003>
- Salokhe, V.M., Soni, P., Nalavade, P.P. & Niyamapa, T. 2010. Performance of Free Rolling and Powered Tillage Discs. *Soil Tillage Research* **109**, 87–93. <https://doi.org/10.1016/j.still.2010.05.004>
- Serrano, J.M. & Peça, J.O. 2008. The forward speed effect on draught force required to pull trailed disc harrows. *Spanish J. Agric. Res.* **6**, 182–188. <https://doi.org/10.5424/sjar/2008062-309>
- Serrano, J.M., Peca, J.O., Marques da Silva, J., Pinheiro, A. & Carvalho, M. 2007. Tractor energy requirements in disk harrow systems. *Biosyst. Eng.* **98**, 286–296. <https://doi.org/10.1016/j.biosystemseng.2007.08.002>
- Serrano, J.M., Peça, J.O., Pinheiro, A., Carvalho, M., Nunes, M., Ribeiro, L. & Santos, F. 2003. The Effect of Gang Angle of Offset Disc Harrows on Soil Tilth, Work Rate and Fuel Consumption. *Biosyst. Eng.* **84**, 171–176. [https://doi.org/10.1016/S1537-5110\(02\)00261-1](https://doi.org/10.1016/S1537-5110(02)00261-1)
- Serrano, J.M., Peça, J.O., Pinheiro, A.C. & Carvalho, M. 2008. Short communication. Evaluation of the energy requirements in tractor-disc harrow systems. *Spanish J. Agric. Res.* **6**, 205–209. <https://doi.org/10.5424/sjar/2008062-321>.
- Upadhyay, G. & Raheman, R. 2018. Performance of combined offset disc harrow (front active and rear passive set configuration) in soil bin. *Journal of Terramechanics* **78**, 27–37. <https://doi.org/10.1016/j.jterra.2018.04.002>
- Zhuk, A.F. & Sokht, K.A. 2018. Arrangement of Spherical Disks for Frontal Harrows. *Agric. Mach. Technol.* **12**, 41–43. <https://doi.org/10.22314/2073-7599-2018-12-4-53-56>