

UNIVERSITÉ DE MONTRÉAL

POSITION LOCATION IN WIRELESS MIMO  
COMMUNICATION SYSTEMS

JI LI

DÉPARTEMENT DE GÉNIE INFORMATIQUE  
ÉCOLE POLYTECHNIQUE DE MONTRÉAL

THÈSE PRÉSENTÉE EN VUE DE L'OBTENTION  
DU DIPLÔME DE PHILOSOPHIAE DOCTOR  
(GÉNIE ÉLECTRIQUE)

NOVEMBRE 2007



Library and  
Archives Canada

Bibliothèque et  
Archives Canada

Published Heritage  
Branch

Direction du  
Patrimoine de l'édition

395 Wellington Street  
Ottawa ON K1A 0N4  
Canada

395, rue Wellington  
Ottawa ON K1A 0N4  
Canada

*Your file* *Votre référence*

*ISBN: 978-0-494-37129-9*

*Our file* *Notre référence*

*ISBN: 978-0-494-37129-9*

#### NOTICE:

The author has granted a non-exclusive license allowing Library and Archives Canada to reproduce, publish, archive, preserve, conserve, communicate to the public by telecommunication or on the Internet, loan, distribute and sell theses worldwide, for commercial or non-commercial purposes, in microform, paper, electronic and/or any other formats.

The author retains copyright ownership and moral rights in this thesis. Neither the thesis nor substantial extracts from it may be printed or otherwise reproduced without the author's permission.

#### AVIS:

L'auteur a accordé une licence non exclusive permettant à la Bibliothèque et Archives Canada de reproduire, publier, archiver, sauvegarder, conserver, transmettre au public par télécommunication ou par l'Internet, prêter, distribuer et vendre des thèses partout dans le monde, à des fins commerciales ou autres, sur support microforme, papier, électronique et/ou autres formats.

L'auteur conserve la propriété du droit d'auteur et des droits moraux qui protègent cette thèse. Ni la thèse ni des extraits substantiels de celle-ci ne doivent être imprimés ou autrement reproduits sans son autorisation.

---

In compliance with the Canadian Privacy Act some supporting forms may have been removed from this thesis.

Conformément à la loi canadienne sur la protection de la vie privée, quelques formulaires secondaires ont été enlevés de cette thèse.

While these forms may be included in the document page count, their removal does not represent any loss of content from the thesis.

Bien que ces formulaires aient inclus dans la pagination, il n'y aura aucun contenu manquant.

  
**Canada**

UNIVERSITÉ DE MONTRÉAL

ÉCOLE POLYTECHNIQUE DE MONTRÉAL

Cette thèse intitulée:

**POSITION LOCATION IN WIRELESS MIMO  
COMMUNICATION SYSTEMS**

présentée par: LI Ji

en vue de l'obtention du diplôme de: Philosophiae Doctor

a été dûment acceptée par le jury d'examen constitué de:

M. FRIGON Jean-François, Ph.D., président

M. PIERRE Samuel, Ph.D., membre et directeur de recherche

M. CONAN Jean, Ph.D., membre et codirecteur de recherche

M. CARDINAL Christian, Ph.D., membre

M. DELISLE Gilles-Y., Ph.D., membre

To Vivian and my family

## ACKNOWLEDGMENTS

I wish to express my sincere gratitude and appreciation to my Ph. D supervisors, Professors Samuel Pierre and Jean Conan, for their guidance, support and encouragement through these years. Professor Pierre gave me the opportunity to be part of his research group and is always available when I need help. I indebted to Professor Conan for the invaluable instruction and many discussions throughout the doctoral program. His insight advice played an important role in shaping the direction and scope of my research.

Special thanks go to Dr. Marc Laforest and Dr. Alehdro Quintero who gave me many constructive suggestions during my research. I also wish to express appreciation to Dr. Gilles-Y. Delisle, Dr. Jean-Francois Frigon, Dr. Christian Cardinal for being my thesis committee members and for their insightful comments and suggestions.

Many people helped me in many ways during my study. I would like to thank all my fellow colleagues at the Laboratoire de recherche en réseautique et informatique mobile (LARIM) and telecommunication lab, and many others for their generous help and encouragement. I am also grateful to my friends Feng Wan, Yufei Wu, Yaohui Lei, for their friendship and help through these years.

Finally, I wish to share this thesis with my family for their constant encouragement and support, and with my wife Vivian who has been very understanding and supportive during the study. This dissertation is dedicated to them.

## ABSTRACT

The rapid growth in demand for location based service has encouraged research into improving the performance of mobile location systems. A promising approach to achieve this goal is the use of antenna array at both the transmitter and receiver sides. Such multiple-input multiple-output (MIMO) communication systems operate by exploiting the spatial properties of the multipath channel, thereby offering new information which can be used to enhance communication performance. In a wireless MIMO system, the parameters such as angle of arrival, angle of departure and delay of arrival of the multipath signals can be estimated using advanced array signal processing techniques.

In this work, we first developed a bidirectional beamforming MIMO channel model which includes physical multipath propagation parameters. After rearranging the estimated channel response by a vectorization scheme, we propose a subspace based approach to jointly estimate the parameters of the multipath signal in MIMO communication systems. The novel approach uses a collection of estimates of a space time manifold vector of the channel which utilizes a Khatri-Rao product to transform the estimated channel response matrix into the classical model. Two Maximum Likelihood methods are derived, and a MUSIC like method is proposed to achieve high resolution of channel parameters. The Cramer-Rao lower bound and simulation results are also provided.

Based on the estimated multipath signal parameters in the context of a MIMO channel, we propose a novel approach to determine the position of mobile stations using *only one Base Station*. This approach intends to minimize the error occurring from the estimation of multiple paths and gives an optimal estimation of the position of mobile station by simultaneously calculating a set of nonlinear algebraic position

equations. The mean square error is measured to demonstrate the performance of the proposed algorithm. The Cramer-Rao lower bound is also derived and compared with the measured MSE. This solution breaks the bottleneck of conventional mobile positioning systems which have to require multi-lateration of at least three base stations. In addition, since this solution takes advantage of the multipath propagation environment, it works well under NLOS environment, the major problem posed by classical trilateration location schemes.

## RÉSUMÉ

La croissance rapide de la demande sur les services mobiles a encouragé la recherche et l'amélioration de la performance des systèmes mobiles. Une approche prometteuse pour atteindre cet objectif est l'utilisation de réseaux d'antennes à l'émetteur et au récepteur. Ce système de communication à entrées et sorties multiples (MIMO) fonctionne en exploitant les propriétés spatiales du canal à trajets multiples, offrant de nouvelles informations qui peuvent être utilisées pour améliorer les performances de communication. Dans un système MIMO sans fil, les paramètres tels que l'angle d'arrivée, l'angle de départ et le retard de propagation des signaux à trajets multiples peuvent être estimés à l'aide des techniques de traitement du signal avancé.

Dans ce travail, nous avons développé un modèle de canal MIMO bidirectionnel qui inclut les paramètres physiques de propagation des trajets multiples. Après la réorganisation des réponses anticipées des canaux par un système de vectorisation, nous proposons une approche basée sur les sous-espaces pour conjointement estimer les paramètres du signal à trajet multiples dans les systèmes de communication MIMO. La nouvelle approche fournit un ensemble d'estimateurs du vecteur espace-temps qui utilise le produit Khatri-Rao pour exprimer le problème d'estimation sous la forme classique. Deux méthodes d'estimation des paramètres du canal à maximum de vraisemblance sont proposées ainsi que l'algorithme MUSIC qui permet d'atteindre une haute résolution. La borne inférieure de Cramer-Rao et les résultats de la simulation sont également fournis.

En se basant sur l'estimation des paramètres des signaux à trajets multiples dans le cadre d'un canal MIMO, nous proposons une nouvelle approche pour déterminer la position des stations mobiles utilisant une seule station de base. Cette approche fournit une estimation optimale de la position de la station mobile en résolvant si-



multanément un ensemble d'équations algébriques non linéaires de position. L'erreur quadratique moyenne est mesurée pour démontrer les performances de l'algorithme proposé. La limite inférieure de Cramer Rao est également dérivée et comparée avec les valeurs d'erreur quadratique mesurées. Cette solution qui n'utilise qu'une base supprime l'obstacle majeur des systèmes de localisation mobile classiques, qui requièrent un minimum d'au moins trois stations de base. En plus, puisque cette solution profite de l'environnement de propagation à trajets multiples, la méthode fonctionne bien sous l'environnement NLOS, ce qui n'est pas le cas pour les systèmes classiques.

## CONDENSÉ

### 1. Introduction et objectif de recherche

Les technologies de localisation de position (PL) ont été traditionnellement des technologies présentant un intérêt pour les militaires et les services de renseignement. En plus des applications classiques de localisation, trouver la position du téléphone mobile devient l'un des problèmes les plus importants des systèmes de communications mobiles. La Commission Fédérale de Communications américaine (FCC) requiert l'accès au numéro d'urgence 911 (E911) pour les services de communications sans fil. L'Union Européenne a manifesté de l'intérêt pour un règlement similaire. D'autres applications sont l'identification automatique de la position (ALI), la facturation automatique et la détection de fraudes aux fournisseurs cellulaires, l'alerte en cas d'accident, le suivi des marchandises, et les systèmes de transport intelligents.

Les travaux de recherche sur les systèmes de positionnement sans fil sont principalement fondés sur des méthodes de triangulation qui nécessitent au moins trois stations de base pour estimer la position du terminal mobile. Le principal problème de ces systèmes est la synchronisation temporelle de toutes les stations de bases concernées. Un autre problème est lié à la présence ou non d'un signal en ligne de vue (LOS, NLOS). En général, il n'existe pas de trajet direct entre la base et le mobile.

Les systèmes de communication sans fil conventionnels ne peuvent estimer que le délai d'arrivée (DOA) du signal reçu dans le but d'accomplir une méthode de localisation (TDOA) par triangulation. Dans les systèmes utilisant les antennes agiles (SMART antennas), l'estimation des angles d'arrivée ainsi que des délais d'arrivée des signaux reçus est possible grâce à des techniques de traitement du signal avancées utilisant le réseau d'antennes. Toutefois, plusieurs stations de base sont toujours nécessaires dans ce cas.

Les travaux récents de recherche sur les systèmes de communication MIMO fournissent de nouvelles idées et des solutions pour satisfaire les besoins actuels en matière de positionnement. L'objectif principal de notre recherche est d'élaborer un nouveau système de positionnement basé sur les systèmes de communication sans fil MIMO. Ce travail peut être essentiellement divisé en deux parties: l'estimation des paramètres communs pour les canaux à trajets multiples MIMO, et l'estimation de position pour un terminal mobile MIMO.

### 1.1 Estimation conjointe des paramètres de trajets multiples d'un système MIMO

L'estimation des paramètres du canal tels que le retard de propagation à l'arrivée (DOA) et l'angle d'arrivée (AOA) d'un signal connu est une des fonctions centrales d'un système de localisation [11, 20, 21]. Les méthodes classiques pour estimer l'angle ou le retard du signal reçu sont basées sur la transmission d'un signal connu, tel qu'une impulsion de forme déterminée, son identification suivie de corrélations ou d'estimations paramétriques séparées [49, 51]. Malheureusement, le signal reçu est composé de multiples réflexions causant des interférences dans le temps et dans l'espace. Les algorithmes classiques d'estimation de l'AOA et le DOA ne sont plus optimaux dans de telles situations [45, 47, 61].

Avec l'application de la technologie des réseaux d'antennes pour la prochaine génération de réseau mobile, plus d'information est disponible. Dans les systèmes de communication MIMO, puisque plusieurs antennes sont utilisées à la transmission et à la réception, on peut résoudre les différents chemins de propagation entre l'émetteur et le récepteur en utilisant des techniques avancées de traitement de signal pour exploiter cette information supplémentaire sur l'angle de départ (AOD). Les méthodes basées sur les sous-espaces telles que MUSIC [51] et ESPRIT [49] permettent d'atteindre de haute résolution dans l'estimation des d'angles et seront utilisées.

### 1.2 Prévision de position d'un système MIMO

Les techniques traditionnelles pour la localisation telle que la recherche de direction, et la mesure de distance sont basées sur la triangulation. Ces systèmes utilisent des mesures prises depuis trois ou plus stations de base pour estimer le positionnement bidimensionnel de l'émetteur portable. Avec l'information supplémentaire sur le AOD qui peut être estimée à partir d'un système MIMO, il est possible de déterminer la position du terminal mobile à partir des signaux à trajets multiples.

## 2. Modèle du canal bidirectionnel

Dans ce travail, nous essayons de mettre au point un modèle de canal bidirectionnel MIMO qui inclut les paramètres physiques multiples (AOA, AOD, DOA, ...). Afin d'estimer conjointement les paramètres du canal à trajets multiples, nous examinerons les conditions suivantes sur le scénario de la propagation radio mobile :

- L'environnement multi-trajet MIMO est modélisé par un certain nombre discret d'ondes paramétrisées par un déphasage, une amplitude complexe (trajet gains), un angle d'arrivée et un angle de départ.
- Les signaux source sont des suites numériques qui sont linéairement modulées par des impulsions de forme connue.
- Les paramètres tels que les AOD, AOA, et DOA ne changent pas significativement d'un créneau temporaire à l'autre.
- Les données transmises par les antennes sont échantillonnées à taux égal ou supérieure au taux de Nyquist.
- Le réseau d'antennes possède une structure connue.

Dans le modèle à trajets multiples illustré à la Fig. 1, nous considérons un canal MIMO muni de deux réseaux linéaires uniformes à l'émission et à la réception. Le

trajet multiple comprend  $R$  chemins de propagation. Chacun est paramétré par  $\theta_r, \phi_r, \tau_r, \beta_r$ . Les paramètres  $\theta_r$  et  $\phi_r$  sont les angles de départ et d'arrivée de la composante  $r$  de l'onde, et  $\beta_r$  et  $\tau_r$  en sont respectivement le gain complexe et le retard de propagation.

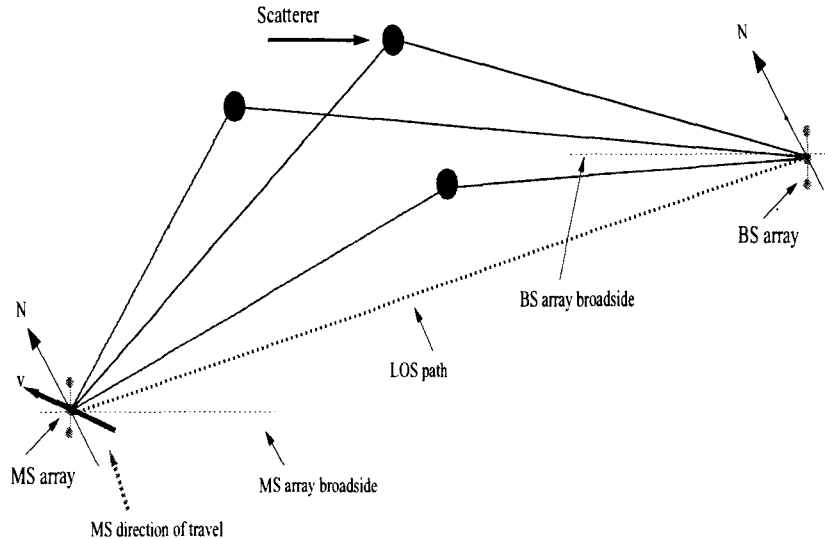

FIGURE 1 A BIDIRECTIONAL BEAMFORMING MIMO PROPAGATION CHANNEL MODEL

Nous utilisons un signal de sonde connu pour estimer la réponse impulsionnelle du canal MIMO qui est requise pour réaliser l'estimation conjointe des paramètres du canal. Des techniques aveugles peuvent aussi être envisagées pour effectuer cette identification. Elles n'ont pas été considérées de façon explicite dans ce travail.

### 3. Estimation conjointe des paramètres de trajets multiples dans les systèmes MIMO

A partir de la réponse impulsionnelle estimée du canal, on peut former un vecteur "espace-temps" auquel on peut appliquer les méthodes classiques d'estimation des sous-espaces telles que le maximum de vraisemblance déterministe, le maximum de vraisemblance dit stochastique ainsi que l'algorithme MUSIC. De plus, le calcul classique de la borne de Cramer-Rao (CRB) peut être étendu à l'espace-temps de notre

modèle.

La méthode de classification "signal multiple" (MUSIC) est un algorithme basé sur la méthode spectrale et repose sur les propriétés de la décomposition en valeurs propres de la matrice de covariance. Les sous-espaces correspondant au signal et au bruit sont orthogonaux. Il n'est pas possible dans un résumé de cette nature de rentrer dans les détails de la procédure MUSIC. Nous renvoyons le lecteur au Chapitre 4 de la thèse pour une analyse fine de la procédure.

Nous nous contenterons à ce point des commentaires suivants:

- Lorsque les signaux reçus arrivent dans le même temps mais de directions différentes ou de mêmes directions mais à des temps différents, les algorithmes d'estimation classiques ne permettent pas de les distinguer. Ce n'est pas le cas avec l'estimation conjointe qui permet la distinction dans ce cas.
- Contrairement aux algorithmes traditionnels fondés sur la méthode des sous-espaces mais n'utilisant qu'un seul réseau d'antennes, l'algorithme d'estimation conjointe MIMO peut fonctionner dans le cas où le nombre de trajets radio est supérieur au nombre d'antennes du réseau.
- Puisqu'il s'agit d'un algorithme spectral à haute résolution pour l'estimation des paramètres du canal, ceux-ci peuvent être obtenus avec une bonne précision même à faible rapport signal sur bruit.

#### 4. Positionnement des terminaux mobiles dans les systèmes MIMO

##### 1) Introduction

En utilisant le complément d'information fourni par le système MIMO sous la forme d'un estimé des angles de départ des ondes, il est possible de repérer la position des

terminaux mobiles en utilisant une seule base. A partir des paramètres complets des trajets multiples (AOD, AOA et DOA) on peut définir un ensemble d'équations non linéaires dont la solution donne les coordonnées 2-D de la source. Une solution est possible par linéarisation suivie de l'application de la méthode des moindres carrés. L'algorithme proposé conduit à minimiser l'erreur quadratique entre la position et les estimés obtenus à partir des équations.

La méthode de positionnement hybride AOA/AOD/TDOA proposé pour les systèmes de communication MIMO est différente des méthodes conventionnelles de positionnement par de nombreux aspects:

- Deux réseaux d'antennes sont nécessaires à l'émission et à la réception.
- Puisque tous les paramètres (AOA, AOD, DOA) peuvent être exploités en canal MIMO, il est possible de repérer la position des terminaux mobiles en utilisant une seule base.
- L'estimation de l'emplacement du terminal mobile peut pleinement utiliser l'approche TDOA/AOA/AOD hybride pour atteindre une plus grande précision.
- Le système étant symétrique, le positionnement peut se faire soit à l'émetteur soit au récepteur, ce qui n'est pas possible dans les systèmes conventionnels.

## 2) Les avantages de la méthode de positionnement MIMO proposée

Du fait que plus de paramètres du signal à trajets multiples peuvent être résolus dans les systèmes de communication MIMO, la méthode hybride TDOA/AOA/AOD de localisation peut tenir compte des angles de départ qui une fois combinés avec les angles d'arrivée et les retards permet le positionnement précis du mobile. On note les avantages suivants en plus du fait qu'une seule station de base est en cause:

- La synchronisation en temps est simple à acquérir. En outre, la collecte de l'information de positionnement par le réseau est grandement facilitée.
- Tous les systèmes classiques de positionnement supposent qu'un chemin LOS est toujours disponible. Notre méthode n'a pas besoin de cette hypothèse. En fait, elle peut même identifier le chemin LOS s'il existe.

## 5. Conclusion

Dans ce travail, nous avons élaboré une nouvelle méthode de mesure de positionnement des terminaux mobiles dans les systèmes MIMO sans fil. La méthode utilise l'estimation conjointe des paramètres du signal à trajets multiples de propagation combinée avec une méthode de calcul de la position des terminaux mobiles basée sur l'utilisation des angles de départ et d'arrivée ainsi que des délais. La méthode proposée ne requiert qu'une seule base pour déterminer la position du mobile.

Les principales contributions de ce travail de recherche sont résumées comme suit:

- En se basant sur le modèle 3GPP du canal MIMO, nous avons élaboré un modèle spéculaire de propagation MIMO à trajets multiples. Chacune des ondes du signal est paramétrée par un retard, une amplitude complexe, un angle d'arrivée et un angle de départ. D'autre part, les paramètres du canal sont supposés être invariants pendant toute la période d'estimation.
- Une approche basée sur la méthode du "sous-espace" est proposée pour estimer conjointement les paramètres du canal (comme les AOD's, DOA's et AOA's) dans un environnement multi-trajet MIMO. Cette nouvelle approche repose sur l'analyse de valeurs propres de la matrice de covariance du canal MIMO.
- Nous proposons aussi une nouvelle approche hybride TDOA/AOA/AOD de localisation des terminaux mobiles utilisant une seule base. La méthode exige



cependant la présence d'au moins trois trajets distincts dans le signal reçu. La méthode de calcul utilise l'estimation au moindres carrés après linéarisation des équations reliant les paramètres à la position. Nous avons testé la viabilité de cette technique par simulations numériques. A notre connaissance, aucune des techniques de positionnement disponibles dans les ouvrages spécialisés ne possède des caractéristiques similaires puisque cette solution élimine le goulot d'étranglement des systèmes conventionnels qui exigent toujours une triangulation requérant plusieurs bases.

## TABLE OF CONTENTS

DEDICATION . . . . .	iv
ACKNOWLEDGMENTS . . . . .	v
ABSTRACT . . . . .	vi
RÉSUMÉ . . . . .	viii
CONDENSÉ . . . . .	x
TABLE OF CONTENTS . . . . .	xviii
LIST OF TABLES . . . . .	xxii
LIST OF FIGURES . . . . .	xxiii
ABBREVIATIONS AND SYMBOLS . . . . .	xxv
CHAPTER 1 INTRODUCTION . . . . .	1
1.1 Background . . . . .	1
1.2 Motivation and Objectives . . . . .	4
1.2.1 Space-time Channel Parameters Estimation . . . . .	5
1.2.2 Location Estimator for MIMO Systems . . . . .	6
1.3 Contributions . . . . .	7
1.4 Organization of the Thesis . . . . .	9
CHAPTER 2 RELATED WORK . . . . .	10
2.1 Wireless Communication Channels . . . . .	10
2.2 Overview of Wireless Position Location Systems . . . . .	11
2.2.1 Classification of Wireless PL System . . . . .	13

2.2.1.1	Handset-Based Technologies . . . . .	13
2.2.1.2	Network-Based Technologies . . . . .	14
2.2.1.3	Hybrid Technologies . . . . .	14
2.2.2	Error Sources in Wireless PL System . . . . .	17
2.2.3	Location Measurement and Principles . . . . .	19
2.2.3.1	Direction Finding Systems . . . . .	19
2.2.3.2	Range-Based Systems . . . . .	20
2.2.4	Location System Controller . . . . .	21
2.2.4.1	Geometric Dilution of Precision . . . . .	22
2.2.4.2	NLOS Error Mitigation . . . . .	22
2.2.5	Location Estimator and Algorithms . . . . .	22
2.2.5.1	AOA-based PL estimator . . . . .	23
2.2.5.2	TDOA-based PL estimator . . . . .	24
2.2.5.3	Hybrid Solution . . . . .	26
2.2.6	Measures of PL Accuracy . . . . .	26
2.3	Fundamentals of Array Signal Processing . . . . .	28
2.3.1	Concepts of Antenna Array . . . . .	28
2.3.2	Adaptive Array Processing and Smart Antenna Systems . . . . .	31
2.3.3	Parameter Estimation . . . . .	33
2.3.3.1	Parameter Estimation Model . . . . .	33
2.3.3.2	Maximum Likelihood Estimator . . . . .	34
2.3.3.3	The MUSIC Algorithm . . . . .	35
2.4	MIMO and Space-time Processing . . . . .	39
2.4.1	Introduction to MIMO Communication Systems . . . . .	39
2.4.2	The MIMO Channel Modeling and Multipath Propagation . . . . .	41
2.5	Conclusions . . . . .	43
CHAPTER 3	BIDIRECTIONAL MIMO CHANNEL MODEL . . . . .	44

3.1	Introduction . . . . .	44
3.2	The System Model . . . . .	47
3.2.1	The Pulse Shaping Scheme . . . . .	47
3.2.2	The SIMO Beam-forming Model . . . . .	48
3.2.3	The MIMO Signal Model . . . . .	52
3.2.4	Considering Oversampling . . . . .	56
3.3	The Bidirectional Beamforming MIMO Channel . . . . .	58
3.3.1	Channel Estimation . . . . .	58
3.3.2	Arrangement of Channel Response for Parameter Estimation . . . . .	59
CHAPTER 4	JOINT ESTIMATION OF MULTIPATH PARAMETERS FOR MIMO SYSTEMS . . . . .	62
4.1	The Proposed Maximum Likelihood Multipath Parameter Estimation Algorithms . . . . .	62
4.1.1	The Deterministic Maximum Likelihood (DML) Method . . . . .	63
4.1.2	The Stochastic Maximum Likelihood (SML) Method . . . . .	64
4.2	The Proposed Subspace-based Multipath Parameter Estimation Algo- rithm . . . . .	65
4.3	The Cramer-Rao Lower Bound . . . . .	66
4.4	Simulation Results and Discussions . . . . .	69
4.5	Conclusions . . . . .	73
CHAPTER 5	POSITION LOCATION OF MOBILE TERMINAL IN MIMO SYSTEMS . . . . .	75
5.1	The Proposed Hybrid TDOA/AOA/AOD Location Method for MIMO Systems . . . . .	75
5.1.1	System Model for Position-Location . . . . .	76
5.1.1.1	Line-of-sight Scenario . . . . .	77
5.1.1.2	Non-Line-of-Sight Scenario . . . . .	78

5.1.2	A Generic Nonlinear Location Estimation Method . . . . .	80
5.1.3	Solution to Hybrid TDOA/AOA/AOD Location Equations . . . . .	85
5.2	Analysis of the Proposed Location Method for MIMO Systems . . . . .	87
5.2.1	Cramer-Rao Lower Bound . . . . .	87
5.2.2	Advantages of Proposed MIMO PL Method . . . . .	88
5.3	Simulations and Results . . . . .	89
5.4	Statistic Results for Geometric Dilution Model . . . . .	94
5.5	Conclusions . . . . .	97
CHAPTER 6 CONCLUSIONS AND FUTURE WORK . . . . .		99
6.1	Review of Main Contributions . . . . .	99
6.2	Future Directions . . . . .	102

**LIST OF TABLES**

TABLE 2.1	Current wireless PL industry leaders . . . . .	13
TABLE 4.1	Value of multipath parameters . . . . .	69
TABLE 5.1	Positions of all scatterers . . . . .	91
TABLE 5.2	Comparison of RMS error with CRLB . . . . .	92

## LIST OF FIGURES

FIGURE 1	A bidirectional beamforming MIMO propagation channel model	xiii
FIGURE 1.1	Multipath propagation channel . . . . .	2
FIGURE 2.1	A typical PL system in cellular network . . . . .	16
FIGURE 2.2	The block diagram of a wireless PL system . . . . .	16
FIGURE 2.3	AOA-based wireless location . . . . .	24
FIGURE 2.4	TDOA-based wireless location . . . . .	25
FIGURE 2.5	Array with plane-wave input . . . . .	29
FIGURE 2.6	Illustration of a Delay-and-sum beamforming structure for linear array . . . . .	30
FIGURE 2.7	Polar plot of beam pattern for N=11 ULA . . . . .	30
FIGURE 2.8	An adaptive array structure . . . . .	32
FIGURE 2.9	Comparison of resolution performance of MVDR, Music and ESPRIT . . . . .	38
FIGURE 2.10	Diagram of a MIMO wireless transmission system . . . . .	39
FIGURE 3.1	A bidirectional beamforming MIMO propagation channel model	46
FIGURE 3.2	Raised cosine pulses for various excess bandwidths . . . . .	48
FIGURE 4.1	Plot of the Music spatial spectrum for Multipath (AOD vs. DOA)	70

FIGURE 4.2	Plot of the spatial spectrum for bidirectional Angle Estimation (AOD vs. AOA) . . . . .	70
FIGURE 4.3	Plot of the resolution of AOA and AOD estimation for six multipaths . . . . .	71
FIGURE 4.4	Performance of the subspace-based algorithm for various SNR's (AOA estimation) . . . . .	72
FIGURE 4.5	Performance of the subspace-based algorithm for various SNR's (DOA estimation) . . . . .	72
FIGURE 5.1	Illustration of the $i$ th scattered path with respect to transmit and receive antenna array . . . . .	77
FIGURE 5.2	Geometry arrangement of scatters between MS and BS . . . . .	90
FIGURE 5.3	Root of squared location error with different scatterers' geometry arrangement . . . . .	91
FIGURE 5.4	The distribution of Squared Error . . . . .	93
FIGURE 5.5	Mean Square Error with different TDOA and AOD noise measurement . . . . .	93
FIGURE 5.6	Cramer-Rao lower bound with different TDOA and AOD noise measurement . . . . .	94
FIGURE 5.7	Geometric dilution model for Scattering . . . . .	95
FIGURE 5.8	Cumulative distribution of RSE location error . . . . .	96
FIGURE 5.9	Distribution of squared location errors . . . . .	97



## ABBREVIATIONS AND SYMBOLS

### Abbreviations

3GPP	3rd generation partnership project
AOA	Angle of arrival
AOD	Angle of departure
AWGN	Additive white Gaussian noise
BER	Bit error rate
BS	Base station
CDMA	Code division multiple access
CRB (CRLB)	Cramer-Rao (lower) bound
DF	Direction finding
DOA	Delay of arrival
E-911	Enhanced 911 public safety services
ESPRIT	Estimation of signal parameters via rotational invariance techniques
FCC	Federal communications commission
GDOP	Geometric dilution of precision
GIS	Geographic information system
GPS	Global positioning system
GSM	Global systems for mobiles
LOB	Line of bearing
LOS	Line of sight

LS	Least-Squares
MAP	Maximum a posteriori probability
MIMO	Multiple input multiple output
ML	Maximum likelihood
MS	Mobile station
MSE	Mean square error
MUSIC	Multiple signal identification and classification
MVDR	Minimum variance distortionless response
NLOS	Non-line of sight
OFDM	Orthogonal frequency-division multiplexing
PL	Position location
RF	Radio frequency
RMS	Root mean square
RSS	Received signal strength
RSSI	Received signal strength indicator
RTOF	Round-time-of flight
SNR	Signal-to-noise ratio
TDOA	Time difference of arrival
TOA	Time of arrival
ULA	Uniform linear array

## Symbols

Throughout this work, vectors are denoted by lowercase boldface or Greek letters with underscore, matrix by boldface capitals or calligraphic capitals, scalar parameters by capitals or lowercase Latin or Greek letters. Other symbols used are:

$[\cdot]^T$	matrix or vector transpose
$[\cdot]^*$	matrix or vector complex conjugate transpose
$[\cdot]^\dagger$	matrix pseudo-inverse (Moore-Penrose inverse)
$*$	convolution operator
$\otimes$	kronnecker product
$\diamond$	Khatri-Rao product, which is a columnwise Kronecker product
<i>trace</i>	trace of a matrix
<i>vec</i>	the column vector obtained by stacking the columns of a matrix
<i>diag</i>	the column vector of the diagonal elements of the matrix
$\mathbf{I}_m$	the $m \times m$ identity matrix
$real\{\cdot\}$	real part of a complex scalar, vector, or matrix
$imag\{\cdot\}$	imaginary part of a complex scalar, vector, or matrix
$ \cdot $	modulus of a scalar, determinant of a matrix
$\ \cdot\ _2, \ \cdot\ $	2-norm of a vector
$\ \cdot\ _F$	Frobenius-norm of a vector
$E[\cdot]$	statistical expectation
$\doteq$	“is defined to be”

## CHAPTER 1

### INTRODUCTION

#### 1.1 Background

Position location (PL) technologies have traditionally been of interest to the military and intelligence communities. In addition to that, finding the location of the mobile phone becomes one of the most important features of the mobile communication systems. The U.S. Federal Communication Commission (FCC) has made Emergency 911 (E911) a mandatory requirement for wireless communications services. The European Union has shown interest in similar regulation. Other than that, Automatic location identification (ALI) will be a system requirement for wireless operators in the near future. PL system can also be used by advanced user hand-off schemes, and potentially many user services for which a GPS is impractical. Other applications are automatic billing and fraud detection for cellular providers, accident reporting, cargo tracking, and intelligent transportation systems [7, 70].

The position of mobile devices can be determined by observing and comparing the signals received from multiple base stations. The traditional techniques for position location such as AOA and TDOA estimation are based on trilateration/multilateration system. These parameters can be measured by using hardware or advanced signal processing techniques.

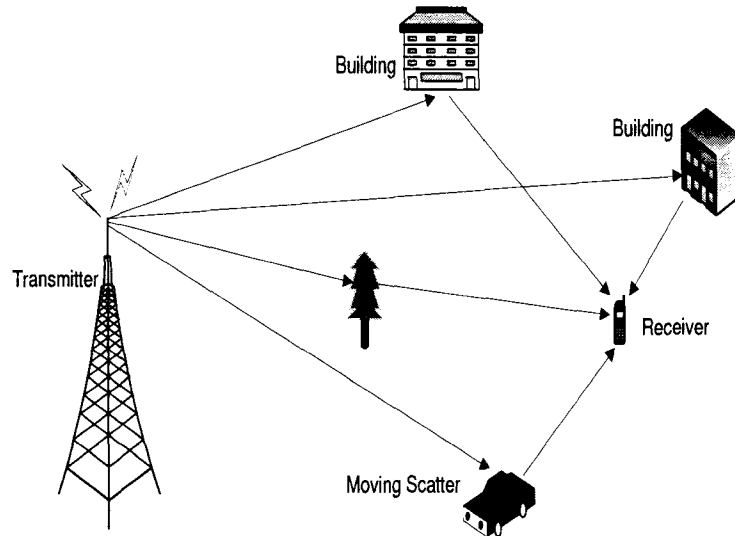

FIGURE 1.1 MULTIPATH PROPAGATION CHANNEL

Due to the radio propagation characteristics that corrupt the wireless communications, previous PL methods have exhibited problems such as time synchronization, NLOS, multipath effect ... etc. Recently, some research showed that multipaths are not as harmful as previously thought for communication systems and that multiple diversity can be exploited to increase capacity even when the channel is unknown. Spatial diversity exploits multiple antennas either separated in space or differently polarized. Different antennas see different multipath characteristics or different fading characteristics and this can be utilized to generate a stronger signal. A typical multipath propagation channel is shown in Figure 1.1

Wireless Multiple-input multiple-output (MIMO) systems have recently emerged as one of the most significant technical breakthroughs in modern communications. MIMO systems use multiple transmit and receive antennas to exploit the spatial properties of the multipath channel, thus offer a new dimension to enable enhanced communication performance. Since wireless MIMO systems can greatly improve system performance in terms of capacity and data rate, MIMO technology will be applied

widely for incoming wireless systems such as 802.16, 802.11n ... etc. one of the key features of MIMO systems is the ability to turn multipath propagation, traditionally a pitfall of wireless transmission, into a benefit for the user.

Modeling MIMO radio channel is essential to understand and analyze the performance of wireless transmission systems. Most of performance investigations have been based on non-physical models, which correspond to a simple stochastic matrix. However, considering wireless multipath wave propagation, physical models of the MIMO channel are alternative models. In such models, the most important and useful parameters of a signal propagating over a MIMO channel are path gain, angles of departure, angles of arrival and delay of arrival.

Traditionally, the problem of estimating angle of received plane wave is referred to as the direction finding estimation problem. It is important in radar, sonar, seismic systems ... etc. Because of its widespread application and the difficulty of obtaining the optimum estimator, the topic has received a significant amount of attention over the last several decades. Recently, it has been extended to estimate delay and frequency of received signal. These parameters can be estimated using adaptive array signal processing techniques.

In a smart antenna system, the radio frequency channel from the transmit to the receive unit can be modeled as a parameter-dependent function for the following reason: most radio propagation environments exhibit the multipath effect, that is, a transmitted signal arrives via multiple paths, each having its own AOA, DOA, and attenuation (fading). Using blind adaptive array processing, these parameters of the received signals could be determined by using prior knowledge of the array response, i.e., the array manifold or special array structure. The high-resolution techniques for AOA estimation include MUSIC and ESPRIT. The knowledge of the AOA of received signal then could be used to track and locate the user. However, in an obstructed line-

of-sight scenario presenting reflected waves, the angle of arrival becomes insufficient and we need to know more parameters like delay of arrival and angle of departure of the propagating signal. Smart antennas systems using adaptive array processing are in fact SIMO or MISO systems. In this work, we try to extend the parameter estimation methods for smart antenna systems to MIMO systems.

As mentioned before, based on estimated parameters of the wireless propagating signals, conventional position location systems use multi-lateration to determine the position of the mobile terminal. However, the performance of these PL systems are highly degraded due to some major obstacles such as multipath, NLOS error and time synchronization problem. In MIMO systems, since more multipath signal parameters (AOD, AOA, DOA...) can be estimated using advanced adaptive array processing techniques, it motivates us to develop new solutions to provide high accuracy for position location of mobile terminal.

## 1.2 Motivation and Objectives

The classical work on wireless PL systems are mainly based on trilateration or multi-lateration techniques which require at least three BSs to estimate the position of the mobile terminal. The main problem of multi-lateration systems is the time synchronization of all involved BSs. Another problem is to distinguish between LOS and NLOS signals. Generally, the first received signal will be treated as the LOS signal, however, it's hard to know whether this signal is a LOS signal. From the structure of the wireless cellular networks, we can easily notice that it does not always exist a LOS path between the mobile device and neighbor BSs. Moreover, for future peer to peer network architecture, the point to point location method will be desired.

With the application of antenna array technology in the next generation mobile net-

works, more channel information can be exploited through space-time processing. For instance, MIMO systems can fully take advantage of multipath effects. In MIMO communication systems, since multiple antennas or antenna arrays are utilized at both sides, they can resolve different propagation paths between a transmitter and receiver by using more advanced array signal processing to exploit more channel information (such as AOD) than smart antenna and point-to-point wireless communication systems. Therefore, new position location methods for MIMO systems need to be developed.

### 1.2.1 Space-time Channel Parameters Estimation

Channel parameter estimation is a classical problem encountered in radar, sonar, wireless positioning systems and future wireless intelligent networks [16]. Furthermore, to understand the characteristics of the spatial radio channel is important for the design of space-time processors. In wideband wireless communications, channel parameter estimation is often an important process to analyze multipath propagation.

Conventional wireless PL systems usually only estimate the delay of arrival of the received signal in order to perform a TDOA location method through trilateration of more than two base stations. In smart antenna systems, the joint estimation of the angle and delay of arrival of the received signals is possible through some advanced array signal processing techniques. However, multiple base stations are still required in this case.

The estimation of channel parameters such as delay and angle for a known received signal is the central functions for location systems [11, 20, 21]. Conventional schemes for estimating the angle and delay of the received signal in a wireless communication system are based on transmitting a known signal, such as a pulse, and performing correlation or parametric estimations separately [49, 51]. Unfortunately, in many



cases, the received signal is composed of multiple reflections having different AOAs and DOAs, which usually causes the signal to overlap in either the time or space domain. The classical algorithms for estimating the AOA and DOA are no longer optimal in such situations [37, 45, 61].

So far, there are many nonlinear parameter estimation problems of interest in the array processing area which includes estimating the spatial (and or/temporal) characteristics of radio propagation channel and estimating the range of a target in the wireless systems [29, 44]. The subspace-based methods such as MUSIC [51] and ESPRIT [49] can achieve high resolution of angles of arrival of received signals. Therefore, they are widely used because of their performance capability. Moreover, the subspace-based methods have various versions and modifications. This motivates us to develop a subspace-based approach for MIMO communication systems to estimate channel parameters. The estimated information can then be used for many applications, for example, to locate the position of mobile terminal in cellular communication systems.

### 1.2.2 Location Estimator for MIMO Systems

In multilateration hyperbolic ranging PL systems, two range-difference measurements produced from three base stations can provide the position of the mobile target, additional measurements from more BSs can be used to reduce the ambiguities due to multipath, signal degradation, and noise. Two well known methods for hyperbolic PL estimation are proposed for TDOA estimation. The first method use Taylor Series expansion to linearize a set of range-difference equations [19]. While the Taylor Series solution is estimated in an iterative manner, a non-iterative solution to the hyperbolic position estimation problem, which capable of achieving optimum performance for arbitrarily placed receivers, was proposed by Chan [9]. The above mentioned PL

estimation system are only for TDOA estimation. Recently, hybrid TDOA/AOA methods have been proposed in [12, 38]. However, all these methods are based on point-to-point or smart antenna system.

In wireless MIMO systems, with multiple antennas or antenna arrays in both transmit and receive sides, it is possible to estimate parameters such as AOA, AOD and DOA in multipath environment. These parameters for MIMO channel need to be exploited by using adaptive array signal processing techniques. With additional AOD information in MIMO systems, it motivates us to estimate the position of mobile terminal from signals of multiple path. If we estimate the TDOA between the first path and other paths, along with the estimation the AOA and DOA for each path, a set of nonlinear location equations can be defined. Solving the established set of nonlinear equations can be performed by linearization. Therefore, new location methods similar to Taylor-series and TSLS solutions can be developed to locate the position of mobile terminal using single base station [33].

### 1.3 Contributions

The research works on MIMO communication system provide new insights and promising solutions to satisfy the current needs. However, parameter estimation for MIMO multipath channel is still an open research area. Furthermore, position location in MIMO systems opens a new research direction for next generation mobile communications. The main objective of this research is to develop a novel PL scheme in wireless MIMO communication systems. This scheme can be mainly decomposed into two parts: joint parameter estimation for MIMO multipath channel, and the location estimation of mobile terminal in MIMO cellular systems. The following works are proposed for this research:

- Based on 3GPP MIMO channel model, we developed a specular MIMO multipath propagation channel model. For an outdoor MIMO channel, we consider a bidirectional beamforming model where the elements of both transmitting and receiving antenna arrays are co-located and the scatterers can be considered as point sources (specular channel model) [54]. This model choose some physical parameters to express the MIMO propagation channel. In this model, we employ uniform linear array (ULA) at both transmitter and receiver sides, each multipaths parameterized by a delay, complex amplitude, angle of arrival and angle of departure. As in many literatures, a quasi-static block-fading channel model is used in this work. The propagation channel is assumed to be constant within one or more time-slots [62].
- A subspace-based approach is proposed to jointly estimate channel parameters (such as AOD, AOA and DOA) in MIMO multipath environment by using a collection of estimates of space-time manifold vector. This new approach rely on analysis of eigenstructure of covariance of MIMO channel transfer matrix to achieve high-resolution estimation of channel parameter. This method, to our knowledge, has so far not been proposed in MIMO multipath parameter estimation. Two Maximum Likelihood methods are derived, and a MUSIC-like method is proposed to achieve high resolution of multipath signal parameters.
- The scattering multipath propagation model for location of the mobile terminal is developed. We assume it's a single bounce model which has only one scatterer for each path. This geometry model utilize jointly estimated channel parameters such as AOA, AOD and DOA to reconstruct the signal propagating path. The TDOAs are computed via the relative DOA between the first arrived signal and other signals.
- We proposed a novel hybrid TDOA/AOA/AOD approach to locate mobile terminals by using only one BS in MIMO communication systems. With more

than three multipath signal available, we developed an over-determined system which could be solved by modified nonlinear LS method. We demonstrate its viability in position location of mobile terminal with numerical experiments. To our knowledge, no similar results for the mobile location technique in MIMO communication systems are available in previously published works. This solution breaks the bottleneck of conventional PL systems which have to require trilateration of at least two BSs. Furthermore, with MIMO systems, the location estimation seems possible at MS side which is not realistic in traditional communication systems.

#### 1.4 Organization of the Thesis

The remainder of this thesis is organized as follows. Related work is given in Chapter 2, in which the relevant preliminaries in wireless position location systems and MIMO space-time communication systems are reviewed. Chapter 3 derives the system model of the bidirectional beamforming MIMO channel with considering oversampling. We also define the concept of space-time manifold vector which utilizes a Khatri-Rao product to transfer the estimated channel response matrix to the classical model for parameter estimation. In Chapter 4, the proposed subspace-based joint parameter estimation method for MIMO multipath channel is proposed, whereas CRLB is also derived. The simulation results and performance analysis are also presented. In Chapter 5, a novel algorithm to calculate the position of mobile terminals by using only one BS in cellular MIMO communication systems is proposed, which involves nonlinear LS estimation and Taylor series linearization. The simulation results with analysis are also reported. Finally, conclusions and future work for this research are given in Chapter 6.

## CHAPTER 2

### RELATED WORK

#### 2.1 Wireless Communication Channels

Wireless communication systems are limited in performance and capacity by major phenomena such as propagation loss, shadowing, fast fading and co-channel interference. Path loss corresponds to the mean signal power attenuation as a function of the propagation distance. The shadowing effect predicts the slow variation of mean signal power at different locations of a fixed transmitter to receiver separation. The phenomenon of fast fading is represented by the rapid fluctuations of the signal over small areas. Multipath propagation results in the spreading of the signal in different dimensions. These are the delay spread, Doppler (or frequency) spread and angle spread. These spreads have significant effects on the signal transmission.

Multipath fading effect occurs in most wireless communication environments. Transmitted signals on their way could meet walls, trees, and other physical entities. This natural phenomenon may induce reflection, refraction, deviation, boomerang, and ultimately these affected signals will take an altogether different path to reach their destination. Some signals even collapse. Thus signals traversing less direct paths arrive at the receiver later and are often attenuated. The excess time delay of the multipath causes time dispersion of the transmitted signal. The time dispersion affects the channel characteristics, and is categorized as either flat fading channels or frequency selective fading channels.

A channel is said to exhibit flat fading when the duration of the transmitted symbol is much larger than the time dispersion of the channel, such that the multipath cannot

be resolved. Viewed in frequency domain, a flat fading channel is one that has a constant amplitude and linear phase response over the transmitted signal bandwidth. This channel has an impulse response that appears to be "flat" in the bandwidth of the transmitted signal, and thus preserve the spectral characteristics of the transmitted signal.

When the bandwidth of constant amplitude and linear phase response of the channel is less than the transmitted signal bandwidth, the spectral characteristic of the signal cannot be maintained. In this case, the channel applied different gain or attenuation to different frequency components of the transmitted signal, causing spectral distortion in the signal. This channel is called the frequency selective fading channel. In the time domain perspective, the time dispersion of the multipath channel is large enough such that some multipaths can be resolved at the receiver into symbol-spaced delay. In other words, a frequency selective fading channel creates intersymbol interference to the transmitted symbols.

With proper pulse shaping and match filtering at the receiver, the frequency selective fading channel can be modeled as a symbol-spaced tap delay line filter. A frequency selective fading channel is a more practical model than flat fading channel for high speed wireless communication where the transmitted signal bandwidth is usually larger than the channel's coherence bandwidth.

## **2.2 Overview of Wireless Position Location Systems**

Wireless position location systems focus on providing Geographic information system (GIS) and spatial information via mobile and field units. The estimated information is used to filter out irrelevant information and provides the context for different services. These services could be offered and executed both with and outside the

mobile operator's network [2, 72].

In 2000 Gravitare Inc. has published a white paper which identifies three evolution steps for PL system. The first generation refers to services where the subscriber has to manually give his position information to the system. The second generation (existing services) refers to location services where the position of the subscriber is automatically discovered but with little accuracy. Finally, the third generation refers to services where the position of the subscriber is automatically discovered with accuracy and which have the intelligence to inform or warn the subscriber about events depending on his position (the subscriber does not have to initiate the service, the initiation depends on triggers according to his preferences).

Location technologies for 3G wireless systems are currently being standardized. These include cell-ID based, assisted GPS(A-GPS), and TDOA-based methods, such as observed TDOA(OTDOA), Enhanced observed time difference (E-OTD) and advanced forward-link trilateration (A-FLT). E-OTD is a TDOA positioning method based on the OTD feature already existing in GSM [66]. In principle, it is similar to OTDOA but operates in TDMA-based networks. A-FLT is in principle a TDOA method and operates in CDMA-based networks. The basic idea of A-FLT method is to measure the phase delay between CDMA pilot signal pairs. Each pair consists of the home BS pilot and neighboring pilot.

In Table 2.1, we list some of the companies currently engaged in wireless PL, and their technologies of location technologies. Most of these companies are focus on GPS-based and TDOA-based methods. The US Wireless Corp and Digital Earth Systems, on the other hand, focus on the statistical signature matching on empirical database.

TABLE 2.1 CURRENT WIRELESS PL INDUSTRY LEADERS

Company	Technology
TruePosition	TDOA
Cell-Loc	TDOA
TeleCommunication Systems Inc.	TDOA
Grayson Wireless	Uplink TDOA (U-TDOA)/AOA
Cambridge Positioning Systems	E-OTD, observed TDOA (OTDOA)
Aerial	E-OTD
SnapTrack (Qualcomm)	Assisted GPS(A-GPS)
US Wireless Corp	Multipath signature matching (MSM)
Digital Earth Systems	Observed propagation data matching (A-OPD)

### 2.2.1 Classification of Wireless PL System

Location enabled technologies that have been proposed to date fall into three broad categories: network-based, handset based, and hybrid in nature. Network-based technologies use the cellular network to determine the location of the mobile devices. Handset-based technologies rely on a modified handset to calculate its own position.

#### 2.2.1.1 Handset-Based Technologies

Handset-based technologies use the radio navigation system provided by the satellites of the U.S. government-operated global positioning system. GPS-based technology uses an embedded GPS receiver in the handset to detect how far it is from at least three satellites of GPS.

GPS-based technology is well suited for many outdoor local positioning tasks. However, GPS has its shortcomings in dense urban areas and inside buildings. Unfortunately, this is exactly the area where heavy, strongly-growing local wireless data transfer takes place. Moreover, it has other drawbacks such as increased cost, size and power consumption of mobile devices. A conventional GPS receiver could take several minutes to acquire the satellite signal and therefore tends to operate continuously



rather than be turned on and off for each acquisition. The drain on the receiver's battery is significant. It also requires line-of-sight to calculate location. The unobstructed line of sight to the orbiting transmitters is important. The satellite signals are weak (below  $10^{-15}$  W) when they arrive at a receiver's antenna, and are further weakened upon entering a building. Because of the drawbacks of non-network-based technologies, cellular carriers generally favor the use of a network-based approach, provided the necessary infrastructure is not prohibitively expensive.

#### **2.2.1.2 Network-Based Technologies**

The network-based location technologies are based on the parameters of the transmission such as signal propagation time and angle of arrival. These technologies typically require considerable expenditure on the network infrastructure but do not require any modifications on the handset. A network-based location overlay system can be implemented by deploying location receiver/processors at either existing base stations or new receiver sites. These location receiver/processors are used to capture signals from the desired mobile unit and to transmit either the captured digitized signal or certain attributes. Preferably, the location receivers will be located at existing cellular antennas and RF front-end circuits.

#### **2.2.1.3 Hybrid Technologies**

Network-assisted GPS hybrid technologies are expected to deliver the accuracy of GPS and overcome the drawbacks of GPS associated with its line-of-sight requirement, and power consumption by shifting significant processing load from the device to the network.

Another viewpoint for examining MS location systems is to consider where the po-

sition measurements are made and where the position information is used. Three broad classifications are made:

- Mobile-based Positioning

In such a system, the MS receiver makes the appropriate signal measurements from several transmitters and uses these measurements to determine its own position. One good example for mobile-based positioning is GPS system.

- Mobile-assisted Positioning

In a mobile-assisted positioning system, receivers at one or more BSs measure a signal originating from the MS to be positioned. These measurements are communicated to a central site (such as a Base Station Controller or Mobile Switching Center) where they are combined to give an estimate of the MS position.

- Indirect Positioning

Using a data link, it is possible to combine position measurements from the MS and BS to make a location estimate. Such hybrid systems are called indirect positioning systems.

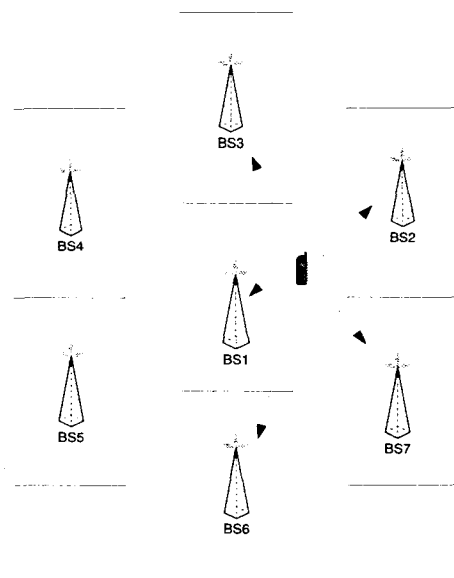

FIGURE 2.1 A TYPICAL PL SYSTEM IN CELLULAR NETWORK

In this research work, we focus on the network-based or mobile-assisted wireless PL system. Figure 2.1 illustrates a typical PL system in cellular networks. In cellular systems, PL technology typically uses BSs or other devices to measure radio signals from MS. A general structure of wireless PL system is illustrated in Figure 2.2. Each part of this structure will be investigated in details in the following sections.

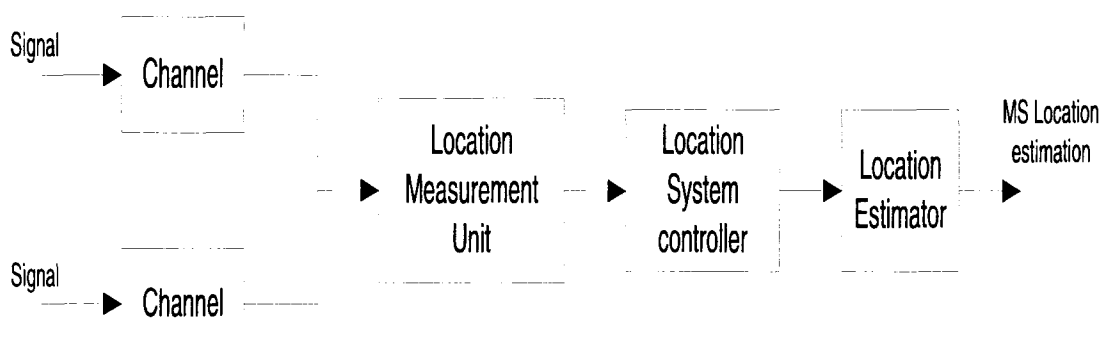

FIGURE 2.2 THE BLOCK DIAGRAM OF A WIRELESS PL SYSTEM

## 2.2.2 Error Sources in Wireless PL System

### Noise

A mobile radio system is beset with noise from various sources and each source may have different characteristics. Firstly, there is receiver thermal noise which is Gaussian in nature and arise from the receiving system itself. Atmospheric noise may also be present, but it decreases rapidly with frequency and is generally, negligible in the VHF range. There is also "man-made" noise which is impulsive in nature and is radiated by electrical equipment of various kind. In wireless communication systems, the noise is often modelled as zero mean Gaussian noise with a certain variance, determined by the signal to noise ratio, measurement resolution, and some other factors.

### Multipath

Multipath is the primary error sources for PL measurement systems. Therefore, techniques for mitigating multipath propagation are extremely valuable for PL systems, and continue to be an open research area. Traditionally, in wireless multipath environment, only the first arrived signal will be processed by PL systems, other multipath signals will be treated as interference and discarded. However, in this work, since more information can be acquired in a MIMO multipath propagation channel, we hope to develop a novel PL method by taking advantage of multipath signals in MIMO communication systems. It's the starting point of this research.

### NLOS

Most PL systems require LOS communication links. However, such direct links do not always exist in reality because of the intrinsic complexity of mobile channels. The average error introduced by NLOS propagation has been measured to be 400-500 meters in the GSM systems [66]. A field test shows that the average NLOS range

error can be as large as 589 m in an IS-95 CDMA system[70]. Therefore, NLOS errors are normally much larger than receiver noise and can degrade the location estimate significantly. NLOS propagation will bias the AOA, TOA and TDOA measurements even when high-resolution techniques are employed and multipath interference is absent.

### **Hearability**

Hearability is the ability of receiving signals from a sufficient number of BSs simultaneously at a sufficient power level, and it is evaluated by the number of BSs that an MS can detect or hear. The higher the value, the better is the hearability [3]. Significantly, there exists an operational conflict between wireless communication and wireless location. Whereas wireless location requires that the MS hear as many BSs as possible to improve location accuracy, wireless communications tries to minimize the power of all signals to mitigate interference and to increase system capacity. As a consequence, it is difficult for an MS to detect enough BSs for location purposes in current cellular phone networks. The lack of available BSs limits the location service coverage area and impedes the implementation of location systems. In order to improve the hearability, the correlation time at the location measurement unit should be increased. Another option is the use of idle period downlink (IP-DL) method [42].

### **Geometric Dilution**

The geometric relationship of receiving BSs will greatly affect the location accuracy. When they are placed in a certain way, a small deviation in measurements can cause a large error in the final estimate. This is called the high Geometric Dilution of Precision(GDOP) error case [59]. GDOP occurs when an MS has a severely degraded location estimate, even if the measurements are fairly accurate.

### 2.2.3 Location Measurement and Principles

The location measurement unit measures the parameters need for location estimation from the received signal corrupted with additive noise, multipath, and /or NLOS errors. Classical parameters include signal strength, direction of arrival, and propagation time of delay of received signal [7, 60]. These parameters can be measured by using hardware or advanced signal processing techniques.

The measurement principle of radio position systems can be classified into two broad categories: Direction Finding (DF) and Range based systems. Direction finding systems estimate the position location of a mobile source by measuring the AOA of the received signals, using parameter estimation methods of array signal processing. Range based PL systems may be categorized as RSS (received signal strength) systems which are mainly based on propagation-loss equations, and propagation-time based systems that can be further divided into three different subclass: Time-of-arrival (TOA), Round-trip-time-of-flight (RTOF) and Time difference-of-arrival (TDOA) [67]. The detailed measurement principle will be present in the following sections.

#### 2.2.3.1 Direction Finding Systems

Direction Finding systems use antenna array at the base station to determine the direction from which the mobile's signal arrives. The AOA measurement restricts the location of the source along a line in the estimated AOA. When multiple AOA measurements are made simultaneously by multiple base stations, a triangulation method may be used to form a location estimate of the source at the intersection of these Lines-Of-Bearing (LOB).

Numerous techniques have been developed to determine the angle of arrival of incident signals on an antenna array. These methods typically are based on the phase difference

of the signal at adjacent elements in the antenna array since this phase difference is proportional to the angle of arrival of the incoming signal. Superresolution techniques have also been developed that take advantage of the structure of the input data model. These methods, including MUSIC and ESPRIT [49, 51], fall into a class of algorithms known as subspace-based techniques.

### 2.2.3.2 Range-Based Systems

- RSS-Based Wireless Location Systems

Received signal strength is based on propagation-loss equations. The free space transmission loss for instance is proportional to  $1/r^2$  ( $r$  is the propagation distance). The major advantage of RSS systems is the fact that most modern radio modules already provide a received signal strength indicator (RSSI). Also the bit error rate (BER) can be used to estimate the signal attenuation. However, for RSS based location systems, high accuracy is difficult to obtain. In a multipath propagation environment, variations in the RSS can be  $30 - 40dB$  over distances on the order of an half wavelength. The power control mechanism employed in cellular systems will impose another difficulty in estimating the location via RSS measurements [67].

- Propagation Time-Based Wireless Location Systems

The propagation time-based PL methods (such as TOA, RTOF, and TDOA) make use of the fact that electromagnetic waves propagate at the constant speed of light. By measuring the propagation times of the signals traveling between the MS and at least three BSs, the distance between the MS and BSs can be obtained, which can then be used to derive the MS location. Due to their physical restraints, AOA and RSS systems only deliver moderate position accuracy, whereas the propagation time-based measurements can achieve higher

accuracy and does not require complex antenna arrays.

The perhaps most intuitive and accurate approach for local position measurement is to measure the RTOF of the signal traveling from the transmitter to the measuring unit and back. Obviously, the time-of-flight can then be used to calculate the distance. In TOA systems, the one-way propagation time is measured and the distance between measuring unit and signal transmitter is calculated. However, there're two main drawbacks of these two approaches: the transmitted signal must be labeled with a time stamp in order for the receiver to discern that the signal has traveled, and precise time synchronization of all involved fixed measuring units and mobile units is required. Therefore, TDOA method is a more practical means of location for commercial systems. In TDOA systems, the time-difference of arrival of the signals received in several pairs of measuring units is evaluated. The benefit of TDOA systems is that it is only necessary to synchronize the measuring units. This synchronization is done using a backbone network or a reference transponder in a known position.

#### **2.2.4 Location System Controller**

Depending on the location scheme used, the location measurement unit passes measured information such as AOA, TOA, or TDOA to the location system controller. The location system controller gathers all the information and select the measurements to be used in the location estimator. The error statistics of each measurement is a major concern for choosing the measurements. The decision to select or reject a measurement can be based on a number of factors.



#### **2.2.4.1 Geometric Dilution of Precision**

This GDOP phenomenon may be used as a means of characterizing the performance of a PL system for various conditions and geometry. The numerical value of the GDOP is defined as the ratio of the RMS position error to the RMS measurement error. The GDOP value can be used to decide whether the BS/MS geometry is appropriate for location estimate. For example, poor BS/MS geometry can lead to high GDOP.

#### **2.2.4.2 NLOS Error Mitigation**

Extensive research on NLOS mitigation techniques have been carried out in the past, as evidenced by the literature [10, 13, 73]. Most of these techniques assume that NLOS corrupted measurements only consist of a small portion of the total measurements. Since NLOS corrupted measurements are inconsistent with LOS expectations, they can be treated as outliers. These algorithms only work well with a large size of samples and small number of outliers. However, the number of available BSs is always limited, and multiple NLOS are likely to occur in a practical situation. Several other approaches [8, 65] are proposed to reduce estimation errors for TOA when the majority are NLOS. By assuming the distributions of NLOS errors are mainly location dependent, some non-parametric approaches based on empirical data from various locations are proposed in [39, 69].

#### **2.2.5 Location Estimator and Algorithms**

The location estimator takes the measurement from the location system controller, and estimate the MS location. A straightforward approach uses a geometric interpretation to calculate the intersection of lines for AOA, circles for TOA and hyperbolas for TDOA. This approach, however, becomes difficult if the lines or curves do not

intersect at a point due to measurement errors.

The traditional techniques for position location such as direction finding and ranging are based on trilateration/multilateration system. Trilateration/multilateration PL systems utilize measurements from three or more BSs to estimate the two-dimensional (2-D) location of the mobile transmitter. In a trilateration hyperbolic ranging PL system, two range-difference measurements produced from three base stations can provide the position of the mobile target, additional measurements from more BSs can be used to reduce the ambiguities due to multipath, signal degradation, and noise.

#### 2.2.5.1 AOA-based PL estimator

Signal AOA information, measured at BSs with an antenna array, can be used for positioning purpose as in Figure 2.3. MS is at the intersection of several direction lines corresponding to AOA measurements. An AOA system normally tries to determine the MS location by solving the following problem [38]:

$$x = \underset{i \in S}{\operatorname{argmin}} \sum \operatorname{dist}(x, \beta_i)^2 \quad (2.1)$$

$$\operatorname{dist}(x, \beta_i) = | -\sin\beta_i(x - x_i) + \cos\beta_i(y - y_i) | \quad (2.2)$$

where  $\beta_i$  is the measured direction angle or direction line between MS and  $BS_i$ ,  $S$  denotes the total number of BSs involved for location estimation, and  $\operatorname{dist}$  is the distance between the calculated MS and the measured direction line  $\beta_i$ .  $(x_i, y_i)$  denotes the position of  $i$ th BS.

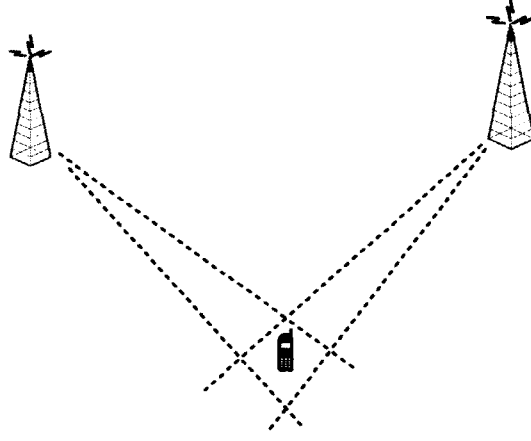

FIGURE 2.3 AOA-BASED WIRELESS LOCATION

### 2.2.5.2 TDOA-based PL estimator

Hyperbolic position location systems estimate the location of a source by the intersection of hyperboloids, which are the set of range-difference measurements between three or more base stations. The range-difference between two receivers is determined by measuring the difference in Time-of-Arrival of a signal between range-difference and the TDOA between receivers is given by:

$$r_{i,j} = c\tau_{i,j} = c(\tau_i - \tau_j) = r_i - r_j \quad (2.3)$$

where  $\tau_{i,j}$  and  $r_{ij}$  are respectively the TDOA and the range difference measurement of the MS to the  $i_{th}$  and  $j_{th}$   $BS_s$ . The TDOA estimate, in the absence of noise and interference, restricts the possible source locations to a hyperboloid of revolution with the receivers as the foci.

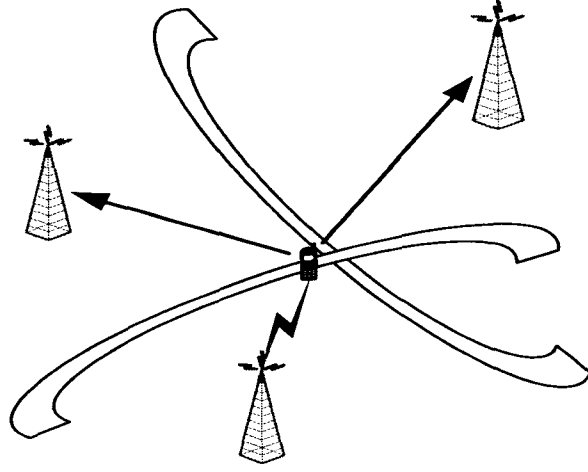

FIGURE 2.4 TDOA-BASED WIRELESS LOCATION

The TDOA system determines the MS position based on trilateration technique, as shown in Figure 2.4. The TDOA scheme is a nonlinear problem. It tries to solve the following optimization problem [38]:

$$\hat{x} = \underset{x}{\operatorname{argmin}} \sum_{i,j \in S, i \neq j} (r_{ij} - \|\|x - X_i\| - \|x - X_j\|\|)^2 \quad (2.4)$$

where  $x$  is MS location,  $S$  is the set of all BSs, and  $X_i$  and  $X_j$  are coordinates of  $BS_i$  and  $BS_j$ .

A major advantage of the TDOA, or Hyperbolic PL, method is that it does not require knowledge of the transmit time from the source. Consequently, strict clock synchronization between the source and receiver is not required. As a result, hyperbolic position location techniques may not require additional hardware or software implementation with the mobile unit. Two well known methods for hyperbolic PL estimation are discussed in details in the following chapter. The first method uses Taylor Series expansion to linearize a set of range-difference equations [19]. While the Taylor Series solution is estimated in an iterative manner, a non-iterative solution

to the hyperbolic position estimation problem, which is capable of achieving optimum performance for arbitrarily placed receivers, was proposed by Chan [9]. The Two-step least square (TSLs) solution is in closed-form and is valid for both distant and close sources. When TDOA estimation errors are small, this method is an approximation to the maximum likelihood (ML) estimator.

### 2.2.5.3 Hybrid Solution

To improve positioning accuracy, it is better to use as much information as possible. A hybrid solution is proposed by simply combining TDOA and AOA measurement as follows [12, 38]:

$$\begin{bmatrix} x_2 - x_1 & y_2 - y_1 & r_{21} \\ \dots & \dots & \dots \\ x_M - x_1 & y_M - y_1 & r_{M,1} \\ \sin\beta_1 & -\cos\beta_1 & 0 \\ \dots & \dots & \dots \\ \sin\beta_N & -\cos\beta_N & 0 \end{bmatrix} \begin{bmatrix} x \\ y \\ r_1 \end{bmatrix} = \begin{bmatrix} (K_2 - K_1 - r_{21}^2)/2 \\ \dots \\ (K_M - K_1 - r_{M1}^2)/2 \\ \sin\beta_1 x_1 - \cos\beta_1 y_1 \\ \dots \\ \sin\beta_N x_N - \cos\beta_1 y_1 \end{bmatrix} \quad (2.5)$$

where  $\beta_i$  is the AOA of MS signal with respect to  $BS_i$ ,  $r_i^2 = (x - x_i)^2 + (y - y_i)^2$ ,  $K_i = x_i^2 + y_i^2$ , and  $r_{i,1} = r_i - r_1$ . The hybrid location estimator can be found in [12, 38]

### 2.2.6 Measures of PL Accuracy

There are some benchmarks to evaluate the accuracy of the position location techniques. A commonly used measure of PL accuracy is the comparison of the MSE of the position location solution to the theoretical MSE based on the Cramer-Rao Lower Bound (CRLB). Another useful measure of PL accuracy is the GDOP. The GDOP

measures the effect of the geometric configuration of the base station on the accuracy of the position location estimate [37].

### **MSE and CRLB**

A commonly used measure of accuracy of a PL estimator is the comparison of the MSE of the PL solution  $(x, y)$  to the theoretical MSE on the CRLB on the variance of unbiased estimators for PL system. The classical method for computing the MSE of a 2-D position location estimate is:

$$MSE = \varepsilon = E[(x - x_v)^2 + (y - y_v)^2] \quad (2.6)$$

where  $(x, y)$  is the position of the source,  $(x_v, y_v)$  is the estimated position of the source, and  $E[ \ ]$  denotes the ensemble average over all channel conditions and hardware anomalies for a user at a particular position location. The RMS location error, which can also be used as a measure of PL accuracy, is calculated as the square root of MSE.

To gauge the best achievable accuracy of the PL estimator, the calculated MSE or RMS PL is compared to the theoretical minimum MSE based on the CRLB. The conventional CRLB sets a lower bound for the variance of any unbiased parameter estimator and is typically used for a stationary Gaussian signal in the presence of stationary Gaussian noise. For non-Gaussian and nonstationary signals and noise, alternate methods have been used to evaluate the performance of the estimators [37]. The derivation of the CRLB for Gaussian noise is provided in [9].

### **Geometric Dilution of Precision**

The accuracy of PL system depends not only on the measurement accuracy, but also on the geometric relationship between the locations of the base stations and the locations of the source. The GDOP quantifies the position accuracy based on this

geometric configuration and is defined as the ratio of the RMS position error to the RMS measurement error. The GDOP for an unbiased estimator and a 2-D hybolic system is given by:

$$GDOP = \sigma_p / \sigma_m = (\sqrt{\sigma_x^2 + \sigma_y^2}) / \sigma_m \quad (2.7)$$

where  $\sigma_p$  is the standard deviation of position estimation;  $\sigma_m$  is the standard deviation of measurement. Finding the smallest GDOP is often used as criterion for selecting a set of base station receivers from a larger set of base station measurements, in order to produce minimum PL estimation error for a particular zone from which mobile users are to operate.

## 2.3 Fundamentals of Array Signal Processing

### 2.3.1 Concepts of Antenna Array

In any wireless system, antennas are used at each end of the link. The antenna is a means of coupling radio frequency power from a transmission line into free space, allowing a transmitter to radiate, and a receiver to capture incident electromagnetic power [20, 21, 37]. An antenna array is a set of antenna elements arranged in space whose outputs are combined to give an overall antenna pattern that can differ from the pattern of the individual elements. An array can achieve the same directional performance of a larger antenna by trading the electrical problems of combining several antenna outputs for the mechanical problems of supporting and turning a large antenna. By varying the phase and amplitude of the individual element outputs before combining, the overall array pattern can be steered in the desired user's direction without physically moving any of the individual elements.

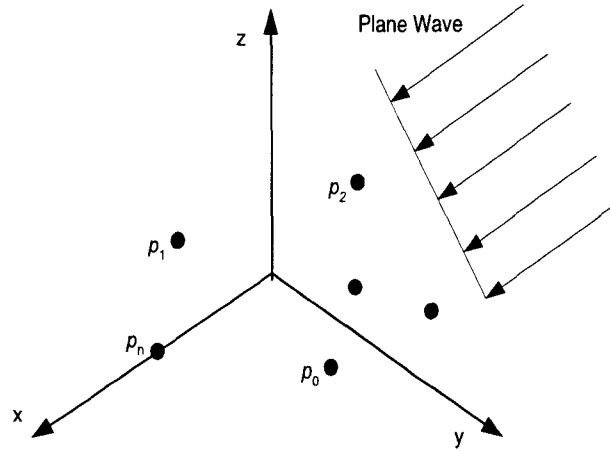

FIGURE 2.5 ARRAY WITH PLANE-WAVE INPUT

To illustrate a simple beamforming operation, consider the case shown in Figure 2.5. The input is a plane wave propagating with temporal (radian) frequency  $\omega$ . The array consists of a set of isotropic sensors located at positions  $\mathbf{p}_n$ ,  $n = 0, 1, \dots, N-1$ . A conventional Delay-and-sum beamformer for a simple  $N$ -element Uniform Linear Array (ULA) which has equally spaced array element along the axis is shown in Figure 2.6. For a planewave incident on the array from direction  $\theta_0$ , the difference in phase between adjacent signal component is:

$$\Phi = \frac{2\pi}{\lambda} d \sin \theta_0 \quad (2.8)$$

where the term  $\lambda$  denotes the wavelength, given by  $c/f$ , where  $c$  is the speed of light,  $f$  is the carrier frequency in Hz, and  $d$  is the space between elements. Then we can define the *array manifold vector* as:

$$\mathbf{v} = \left[ 1 \quad e^{-j\Phi} \quad \dots \quad e^{-j(N-1)\Phi} \right]^T \quad (2.9)$$



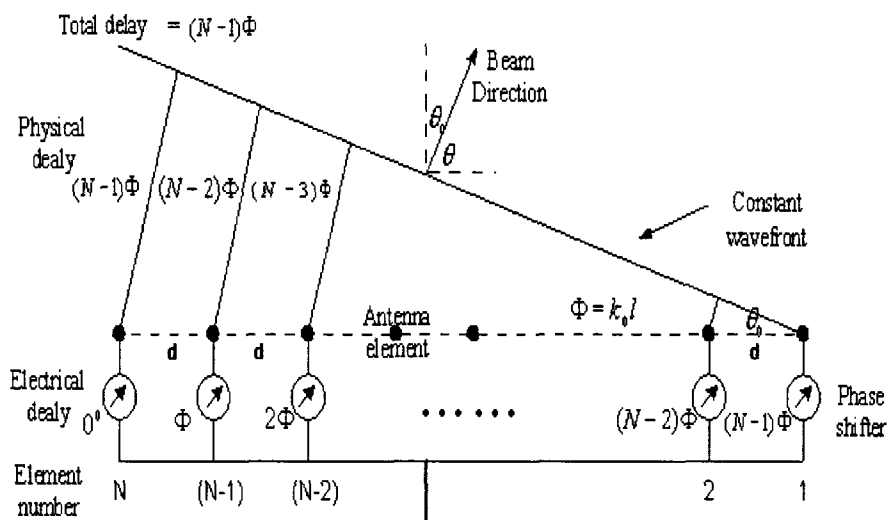

FIGURE 2.6 ILLUSTRATION OF A DELAY-AND-SUM BEAMFORMING STRUCTURE FOR LINEAR ARRAY

Figure 2.7 shows a polar plot of beam pattern for 11-element uniform linear array.

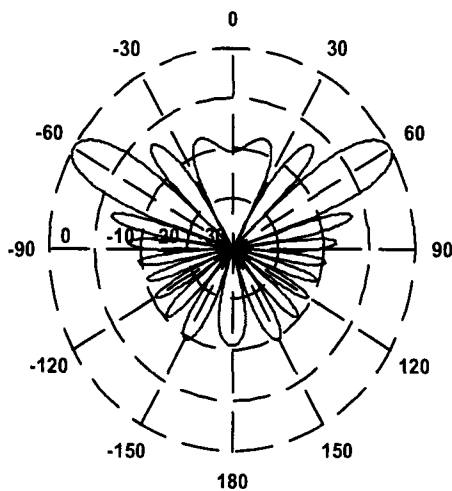

FIGURE 2.7 POLAR PLOT OF BEAM PATTERN FOR  $N=11$  ULA

### 2.3.2 Adaptive Array Processing and Smart Antenna Systems

According to their work pattern, the antenna arrays for wireless communications can be divided into two classes: switched beam system and adaptive arrays system. The switched beam system utilizes antenna arrays to perform some narrow beam which point to each direction. It's equivalent to cover  $N$  radiant areas with  $N$  antennas. While the users move from one area to another, the system switches from one beam to another by monitoring the signal strength, and tracking the user by selecting the right area. The switched beam pattern can be regarded as partial adaptation to the mobile communication environment. In array antenna systems which use only the fixed performing method, a switch is used to select the best beam to receive a particular signal. The switched beam is relatively simple to implement, requiring only a performing network, an RF switch, and control logic to select a particular beam.

An adaptive antenna array consists of an array of antenna elements and an adaptive receiver-processor. Given a beam-steering command, the adaptive processor takes samples from the antenna elements and automatically adjusts element control weights according to some optimization criterion. Typically, the weights are chosen to maximize the output signal-to-noise-ratio or the signal-to-interference-plus-noise-ratio (SINR).

The adaptive antenna arrays use adaptive algorithms to form the beam to point the desired user real time in order to track and locate the user, thus effectively suppressing the interference signal and enhancing the desired signal. The adaptive array antennas adjust the beam direction from time to time according to the variant of signal propagation environment without pre-form the fixed beam. It has better performance than beam switched systems, but with complicated implementation. Figure 2.8 shows an example of adaptive array, the weight vector  $\underline{\omega}_{k,i}$  is adjusted, or adapted to maximize the quality of the signal that is available to the demodulator

for signal  $k$  at time index  $i$  [37].

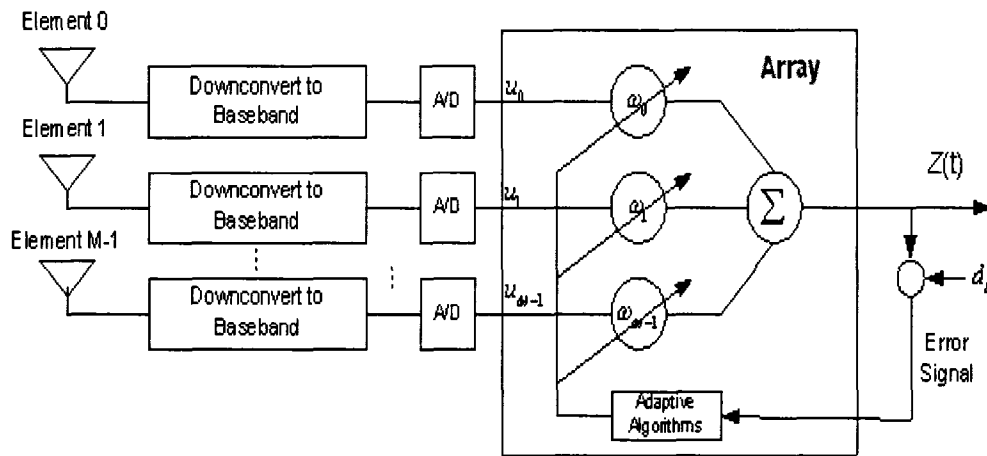

FIGURE 2.8 AN ADAPTIVE ARRAY STRUCTURE

Antenna array processing in wireless communications are called smart antenna systems. In the conventional smart antenna terminology, only the transmitter or the receiver is actually equipped with more than one element, being typically the base station, where the extra cost and space have so far been perceived as more easily affordable than on a small phone handset. Smart antenna can provide significant performance in existing wireless cellular systems which utilize various types of multiple access technique such as TDMA, FDMA and CDMA. Adaptive arrays give wireless providers the ability of forming a main beam in the direction of each user. Antenna arrays can combat multipath fading of the desired signal and suppress interfering signals, thereby increasing both the performance and capacity of wireless systems. A theoretical study showed that a base station with an adaptive array antenna could handle three times as many users in a cell as a base station with an omni-directional antenna [11]. An additional benefit of antenna arrays is that high resolution direction of arrival algorithms such as maximum likelihood, MUSIC, and ESPRIT can be used to estimate the angles of arrival of incoming signals to sub-degree accuracy. Therefore, antenna arrays are widely used to solve DF problems.

Simple linear antenna array combining can offer a more reliable communications link in the presence of adverse propagation conditions such as multipath fading and interference. A key concept in smart antennas is that of beamforming by which one increases the average SNR through focusing the energy into desired directions, in either the transmit or the receiver. Indeed, if one estimates the response of each antenna element to a given desired signal, and possibly to interference signal, one can optimally combine the elements with weights selected as a function of each element response. One can then maximize the average desired signal level or minimize the level of other components whether noise or co-channel interference.

### 2.3.3 Parameter Estimation

Position Location evolves from the classical direction finding problem in array signal processing. These techniques try to estimate the angle-of-arrival (AOA) of the source. They include maximum likelihood estimation, Capon's minimum variance method (MVDR) [37, 61], and subspace based estimation (MUSIC and ESPRIT ) [37, 49, 51, 61].

#### 2.3.3.1 Parameter Estimation Model

A number of methods are available in the literature for estimating the signal parameters in the classical model

$$\mathbf{x}(k) = \mathbf{V}\mathbf{s}(k) + \mathbf{n}(k) \quad (2.10)$$

where the  $i_{th}$  column of matrix  $\mathbf{V}$ , denoted by  $\mathbf{v}_i$ , represents array manifold vector of signal  $s_i(k)$  which is transmitted by source  $i$  ( $i = 1, 2, \dots, D$ ).  $\mathbf{v}_i$ s reflect different time

delays of the signals at different antennas. The vector

$$\mathbf{s}(k) = [s_1(k), s_2(k), \dots, s_D(k)]^T \quad (2.11)$$

is the unknown signal vector.  $\mathbf{n}(k)$  is the additive measurement noise.

For an isotropic  $M$ -element linear array along  $Z$ -axis with uniform spacing  $d = \lambda/2$ , where  $\lambda$  is signal wavelength:

$$\mathbf{v}_i = [1, e^{j\pi \sin \phi_i}, e^{j2\pi \sin \phi_i}, \dots, e^{j(M-1)\pi \sin \phi_i}]^T \quad (2.12)$$

### 2.3.3.2 Maximum Likelihood Estimator

Maximum Likelihood (ML) techniques [37,61] are some of the first techniques to be investigated for AOA estimation. Since ML techniques were computationally intensive, they were less popular than suboptimal subspace techniques, especially in low signal-to-noise ratio conditions or when the number of signal samples is small. However, ML based techniques can perform well in correlated signal environments. Moreover, under some practical conditions, the ML estimators is unbiased and, asymptotically its variance approaches the Cramer-Rao bound.

Assume the noise is an ergodic complex-valued Gaussian process of zero mean and covariance  $\sigma^2 \mathbf{I}$ , where  $\sigma^2$  is an unknown scalar and  $\mathbf{I}$  is the identity matrix, the joint probability density function of the sampled data as given by equation (2.10) can be expressed as:

$$p(\mathbf{x}) = \prod_{k=0}^{N-1} \frac{1}{\pi \det[\sigma^2 \mathbf{I}]} \exp\left(-\frac{|\mathbf{x}(k) - \mathbf{V}(\phi)s(k)|^2}{\sigma^2}\right) \quad (2.13)$$

where  $\det[\cdot]$  denotes the determinant. Ignoring the constant terms, the log likelihood

function is given by:

$$J = -ND \log \sigma^2 - \frac{1}{\sigma^2} \sum_{k=0}^{N-1} |\mathbf{x}(k) - \mathbf{V}(\underline{\phi})s(k)|^2 \quad (2.14)$$

Maximizing equation(2.14) is equivalent to the following minimization:

$$\min_{(\underline{\phi}, \mathbf{S})} \left\{ \sum_{k=0}^{N-1} |\mathbf{x}(k) - \mathbf{V}(\underline{\phi})s(k)|^2 \right\} \quad (2.15)$$

where  $\mathbf{S} = E[s(k)s^H(k)]$ .

Fixing  $\underline{\phi}$  and minimizing with respect to  $\mathbf{S}$ , yields the well known least squares solution:

$$\hat{\mathbf{s}}(k) = (\mathbf{V}^H(\underline{\phi})\mathbf{V}(\underline{\phi}))^{-1}\mathbf{V}^H(\underline{\phi})\mathbf{x}(k) \quad (2.16)$$

The ML estimation of the DOA  $\underline{\phi} = \phi_1, \dots, \phi_{D-1}$  is obtained by maximizing the log-likelihood function:

$$\mathbf{J}(\underline{\phi}) = \sum_{k=0}^{N-1} |\mathbf{P}_{V(\underline{\phi})}\mathbf{x}(k)|^2 \quad (2.17)$$

where  $\mathbf{P}_{V(\underline{\phi})}$  is the projection operator which projects vectors onto the space spanned by the columns of  $\mathbf{V}(\underline{\phi})$ , and is given by:

$$\mathbf{P}_{V(\underline{\phi})} = \mathbf{V}(\underline{\phi})(\mathbf{V}^H(\underline{\phi})\mathbf{V}(\underline{\phi}))^{-1}\mathbf{V}^H(\underline{\phi}) \quad (2.18)$$

### 2.3.3.3 The MUSIC Algorithm

The MUSIC proposed by Schmidt in 1979 [51] is a subspace based high resolution multiple signal classification technique that can be used to accurately estimate the number of incident signals and the direction of arrivals of the signals by exploiting the eigen-structure of the input covariance matrix. The term "high-resolution" refers

to the fact that the frequency estimation or angle of arrival estimation has, under carefully controlled conditions, the ability to surpass the limiting behavior of classical Fourier-based methods [27]. This algorithm divides the space spanned by the eigenvectors of the input covariance matrix of the received signal into two subspaces - signal plus noise subspace and the noise subspace.

Considering a uniformly spaced linear array of  $M$  identical isotropic antenna elements and if  $D$  signals arriving at the linear array, then the received signal can be represented by the equation [37]:

$$\mathbf{x}(t) = \sum_{l=0}^{D-1} \mathbf{v}(\phi_l) s_l(t) + \mathbf{n}(t) \quad (2.19)$$

Writing the above equation in matrix form,

$$\mathbf{x}(t) = \begin{bmatrix} \mathbf{v}(\phi_0) & \mathbf{v}(\phi_1) & \cdots & \mathbf{v}(\phi_{D-1}) \end{bmatrix} \begin{bmatrix} s_0(t) \\ s_{D-1}(t) \end{bmatrix} + \mathbf{n}(t) = \mathbf{V}\mathbf{s}(t) + \mathbf{n}(t) \quad (2.20)$$

Taking the autocorrelation of equation(2.20),

$$\mathbf{R}_{xx} = E[\mathbf{x}(t)\mathbf{x}(t + \tau)^H] = E[(\mathbf{V}\mathbf{s}(t) + \mathbf{n}(t))(\mathbf{V}\mathbf{s}(t) + \mathbf{n}(t))^H] \quad (2.21)$$

where  $H$  denotes Hermitian transpose. Dropping the time argument of the vector for simplicity and using the assumption that the noise is uncorrelated with the signals, we can arrive at the following expressions using basic linear algebra:

$$\mathbf{R}_{xx} = \mathbf{V}E[\mathbf{s}\mathbf{s}^H]\mathbf{V}^H + E[\mathbf{n}\mathbf{n}^H] = \mathbf{V}\mathbf{R}_{ss}\mathbf{V}^H + \sigma^2\mathbf{I} \quad (2.22)$$

where we assume that the noise at each of the array element is additive white Gaussian, and the mean of each signal arriving at the antenna elements is zero.  $\mathbf{R}_{ss}$  denotes the correlation or the covariance matrix of the incoming signals.

The eigen values of  $\mathbf{R}_{xx}$  can be found by solving the equation:

$$|\mathbf{R}_{xx} - \lambda_i \mathbf{I}| = 0, i = 0, 1, \dots, M - 1 \quad (2.23)$$

where  $|\cdot|$  represents the determinant. From these eigen values, the eigen values of  $\mathbf{V}\mathbf{R}_{ss}\mathbf{V}^H$  can be found as:

$$v_i = \lambda_i - \sigma_n^2 \quad (2.24)$$

It can be shown that when the number of incident signals  $D$  is less than the number of antenna elements  $M$ ,  $(M - D)$  eigen values of  $\mathbf{V}\mathbf{R}_{ss}\mathbf{V}^H$  are zero. If the eigen values of  $\mathbf{R}_{xx}$  are sorted in descending order, then the  $(M - D)$  largest eigen values of  $\mathbf{R}_{xx}$  can be seen to be:

$$\lambda_i = \sigma_n^2, \quad i = D, D + 1, \dots, M - 1 \quad (2.25)$$

It can be shown that the eigen vectors of  $\mathbf{R}_{xx}$  corresponding to the  $(M - D)$  equal eigen values found above satisfy the following equation [37]:

$$\mathbf{V}^H \mathbf{q}_i = 0, i = D, D + 1, \dots, M - 1 \quad (2.26)$$

where  $\mathbf{q}_i$ ,  $i = D, D + 1, \dots, M - 1$  are the eigen vectors of  $\mathbf{R}_{xx}$  whose corresponding eigen values are nearly equal to  $\sigma_n^2$ .

In other words, the array propagation vectors corresponding to each of the incident signals are orthogonal to the eigen vectors of  $\mathbf{R}_{xx}$  whose corresponding eigen values are nearly  $\sigma_n^2$ . Thus spatial searching for the incoming signals can be done by calculating the array propagation vector  $\mathbf{v}_{\underline{\phi}}$ ,  $-\pi/2 \leq \underline{\phi} \leq \pi/2$  and checking if it is orthogonal to each of the eigen vectors  $\mathbf{q}_i$ ,  $i = D, D + 1, \dots, M - 1$ .

The DOA's of each of the incident signals can be estimated by plotting the spatial



spectrum given by the expression [37].

$$P_{music}(\underline{\phi}) = \frac{\mathbf{v}^H(\underline{\phi})\mathbf{v}(\underline{\phi})}{\mathbf{v}^H(\underline{\phi})\mathbf{U}_n\mathbf{U}_n^H\mathbf{v}(\underline{\phi})} \quad (2.27)$$

where

$$\mathbf{U}_n = [\mathbf{q}_D \quad \mathbf{q}_{D+1} \quad \cdots \quad \mathbf{q}_{M-1}] \quad (2.28)$$

and locating the peaks in the plot.

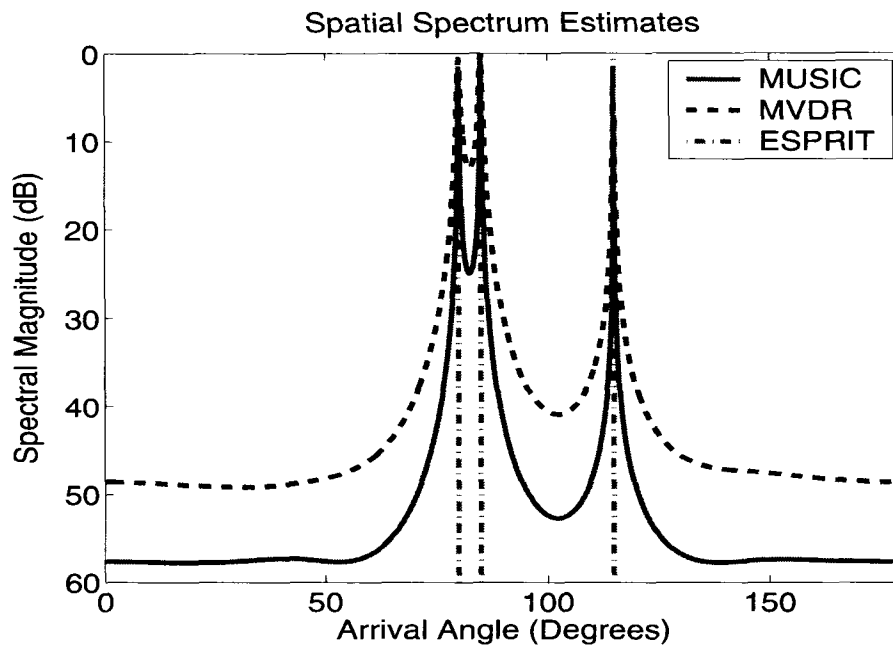

FIGURE 2.9 COMPARISON OF RESOLUTION PERFORMANCE OF MVDR, MUSIC AND ESPRIT

Figure 2.9 illustrates the performance improvement obtained by Music and ESPRIT method over the MVDR method. Here three equal power (each has a SNR of 20dB) sinusoidal signals of different frequencies, arriving at angles of 80, 85 and 115 degree respectively were incident on a uniform linear array of 6 elements. Matlab simulation shows that Music exhibits better resolution than MVDR method, while ESPRIT gives

a closed-form solution.

## 2.4 MIMO and Space-time Processing

### 2.4.1 Introduction to MIMO Communication Systems

MIMO systems can be defined simply. Given an arbitrary wireless communication system, we consider a link for which the transmitting end as well as the receiving end is equipped with multiple antenna elements. Such a system is illustrated in Fig. 2.10. The idea behind MIMO is that the signals on the transmit (Tx) antennas at one end and the receive (Rx) antennas at the other end are "combined" in such a way that the quality (bit-error rate or BER) or the data rate (bits/sec) of the communication for each MIMO user will be improved. Such an advantage can be used to increase both the network's quality of service and the operator's revenues significantly.

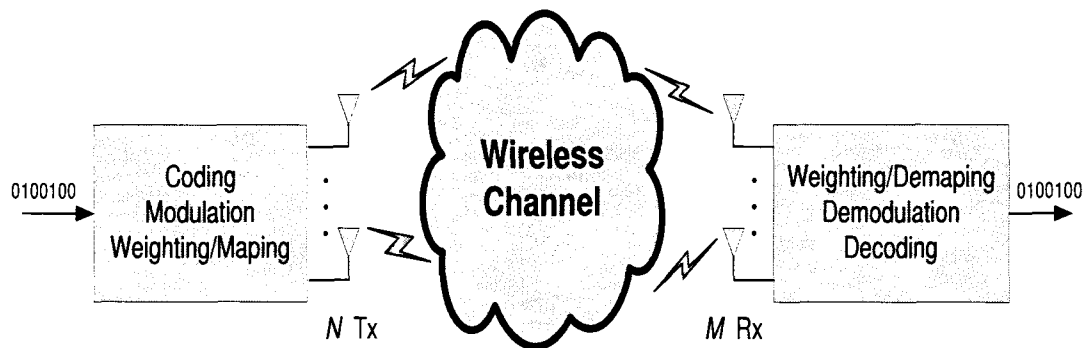

FIGURE 2.10 DIAGRAM OF A MIMO WIRELESS TRANSMISSION SYSTEM

A key feature of MIMO systems is the ability to turn multipath propagation, traditionally a pitfall of wireless transmission, into a benefit for the user. MIMO effectively takes advantage of random fading [28] and when available, multipath delay spread [48], for multiplying transfer rates. The prospect of many orders of magnitude im-

provement in wireless communication performance at no cost of extra spectrum (only hardware and complexity are added) is largely responsible for the success of MIMO as a topic for new research. This has prompted progress in areas as diverse as channel modeling, information theory and coding, signal processing, antenna design and multiantenna-aware cellular design, fixed or mobile.

Because MIMO transmits multiple signals across the communications channel, MIMO has the ability to multiply capacity, which is another word for speed. A common measure of wireless capacity is spectral efficiency—the number of units of information per unit of time per unit of bandwidth. MIMO approach is turning out to be a compelling method that addresses the wireless communication challenges of signal fading, increasing interference and limited spectrum. MIMO multiplies the data throughput and provides for a simultaneous increase in range and reliability all without consuming extra radio frequency. It is a multidimensional approach that transmits and receives two or more unique data streams through one radio channel whereby the system delivers two or more times the data rate per channel.

For both transmitter and receiver, MIMO exploits the use of multiple signals transmitted into the wireless medium and multiple signals received from the wireless medium to improve the wireless performance significantly. Using multiple antennas, MIMO uses spectrum more efficiently without sacrificing the reliability. Before MIMO flourishes, speed could be increased only by sacrificing range and reliability. Range could be extended at the expense of speed and reliability. And reliability could be improved by reducing speed and range. MIMO technology may provide Spatial Division Multiplexing (SDM). spatial multiplexing essentially sends multiple data streams through the same RF channel simultaneously. This technology turns the normally villainous multipath into an asset, presumably delivering greater range and greater bandwidth at a given range.

### 2.4.2 The MIMO Channel Modeling and Multipath Propagation

Assessing the potential performance of MIMO systems in realistic environments requires a detailed description of the multipath channel under investigation. This description must go beyond traditional models, as we must accurately represent a matrix of transfer functions. In some cases, channel measurements are used to fully characterize these channels. However, since relatively few such campaigns have been performed and the resulting data is not widely available, many researchers have turned to channel models that capture the key behaviors observed in the experimental data [14, 46, 50]. When accurate, these models facilitate performance assessment of potential space-time coding approaches in realistic propagation environments. Several works have been reported in this area and the proposed models can be classified in different ways.

#### Wideband Models vs. Narrowband Models

The MIMO channel models can be divided into the wideband models and the narrowband models directly by considering the bandwidth of the system. The wideband models treat the propagation channel as frequency selective, which means that different frequency sub-bands have different channel response. On the other hand, the narrowband models assume that the channel has frequency non-selective fading and therefore the channel has the same response over the entire system bandwidth. Wideband MIMO channel models can be found in [30, 46, 74, 75] while [15, 53] treat narrowband models.

#### Field Measurements vs. Scatterer Models

To model the MIMO channel, one approach is to measure the MIMO channel responses through field measurements. Some important characteristics of the MIMO channel can be obtained by investigating the recorded data and the MIMO chan-

nel can be modeled to have similar characteristics. Models based on MIMO channel measurements were reported in [31, 40, 41]. An alternative approach is to postulate a model (usually involving distributed scatterers) that attempts to capture the channel characteristics. Such a model can often illustrate the essential characteristics of the MIMO channel as long as the constructed scattering environment is reasonable. Examples of scatterer models can be found in [14, 53].

### **Non-physical Models vs. Physical Models**

The MIMO channel models can be divided into the non-physical and physical models [30, 46, 74, 75]. The non-physical models are based on the channel statistical characteristics using non-physical parameters. In general, the non-physical models are easy to simulate and provide accurate channel characterization for the situations under which they were identified. On the other hand they give limited insight to the propagation characteristics of the MIMO channels and depend on the measurement equipment, e.g. the bandwidth, the configuration and aperture of the arrays, the heights and response of transmit and receive antennas in the measurements. The influence of the channel and measurement equipment on the model can not be separated. Another category are the physical models. In general, these models choose some crucial physical parameters to describe the MIMO propagation channels. Some typical parameters include AOA, AOD, DOA.

A common strategy for dealing with weaker multipath signals is to simply ignore them-in which case the energy they contain is wasted. MIMO, in contrast, takes advantage of multipath propagation to increase the much-wanted throughput, range/coverage, and reliability. Rather than combating the multipath signals, MIMO intelligently use those signals to carry more bits of information thereby saving a lot of energy and guaranteeing the longevity of the expensive wireless infrastructures. That is, the high performance is accomplished by sending and receiving more than

one data signal in the same radio channel at the same time.

## 2.5 Conclusions

In this chapter, we first give an overview of the current position location systems. In principle, wireless PL system can be implemented on direction finding approach and range-based approach, or their combination. By introducing the concept of array processing, we present the classical parameter estimation techniques which include Maximum Likelihood and subspace-based methods. In order to extend the classical parameter estimation methods in wireless MIMO systems, we give an brief introduction to MIMO communication systems, and we also provide the classification of MIMO channel model.

## CHAPTER 3

### BIDIRECTIONAL MIMO CHANNEL MODEL

#### 3.1 Introduction

MIMO systems offer a new dimension by exploiting the spatial property of the multipath channel [14, 17]. Therefore in a wireless MIMO system, it is possible to estimate more channel parameters due to the multipath environment. Recently, double-directional estimation methods have been proposed to estimate both angles of departure on the transmit site and angles of arrival on the receive site simultaneously [55]. However, the estimation of channel features has to include some other parameters such as the delay of arrival.

Traditionally, to estimate the channel, some known training signals are sent during some portion of the transmission interval. The training-based schemes can be divided into training phase and data transmission phase [26]. During the training phase, knowing the received signals at receiver and training signals at transmitter, we can estimate channel matrix using several training-based channel estimation algorithms i.e. Least Squares, Maximum Likelihood, Maximum a posteriori (MAP) and Maximum Mean Square Error (MMSE) algorithms [4, 62]. The estimated channel matrix is then used in the succeeding data transmission phase to obtain the desired data.

In this work, we first develop a bidirectional beamforming MIMO channel model which includes the physical multipath parameters (AOA, AOD, DOA, ...). We then use a training based scheme to estimate the MIMO channel impulse response. After rearranging the estimated channel response by vectorization, the conventional

parameter estimation model discussed in chapter 2 can be modified to achieve high resolution of multipath parameters such as AOA, AODs and DOAs.

In many of the literature, a quasi-static block-fading channel model is used. The propagation channel is assumed to be constant during the estimation process [62]. As mentioned before, when multipath is considered, the channel usually experience frequency-selective fading. Therefore, the propagation channel considered in this work is block frequency-selective channel. There are two different multipath MIMO frequency selective channel models (or combination model of them) corresponding to different assumptions about the geometry of antenna arrays and scatterers [54].

- **Beamforming model:** In this model, the elements of both transmit and receive antenna arrays are co-located and the scatterers can be considered as point sources. Each multipath channel is characterized by a AOD and AOA, a delay and a complex fading amplitude. In general, this model is fit for outdoor channels. The MIMO model in the 3rd Generation Partnership Project (3GPP TR 25.996) adopts this approach.
- **Diversity model:** The elements of the transmit and/or receive antenna arrays are not necessary co-located and/or the different scatterers are modeled as distributed sources. This model is generally suitable for an indoor channel. In this model, the channel gains between different transmit and receive antennas is modeled as spatially and temporally correlated jointly Gaussian random variable with zero/nonzero mean (Rayleigh /Ricean fading). The MIMO model for wireless LAN in IEEE P802.11 (IEEE 802.11-03) uses this type of model.

In this work, we consider a simplified 3GPP MIMO channel model [1] which is bidirectional beamforming propagation channel model illustrated as Fig.3.1. In this outdoor beamforming model, we assume there is only one path that goes through each scat-



terer. Each path has its own AOD, AOA, and the delay between each pair of paths can also be measured.

For a  $(N, M)$  MIMO transmission system, there exists  $N \times M$  wireless channels from the transmit antennas to the receive antennas, and each of these wireless channels experience frequency selective fading. These channels can be modeled as an equivalent symbol-spaced tap delay line with  $L$  channel taps. Each channel tap gains are assumed to be independent to each other in a rich scattering scenario. Moreover, the number of channel taps for all  $N \times M$  are assumed to be the same. This assumption is made because in wave propagation, the delay profile of the channels are mainly due to reflection off large objects. As the antennas are not separated very far apart and are in similar environment, all the  $N \times M$  channels should have similar delay spread, but with different fading coefficients.

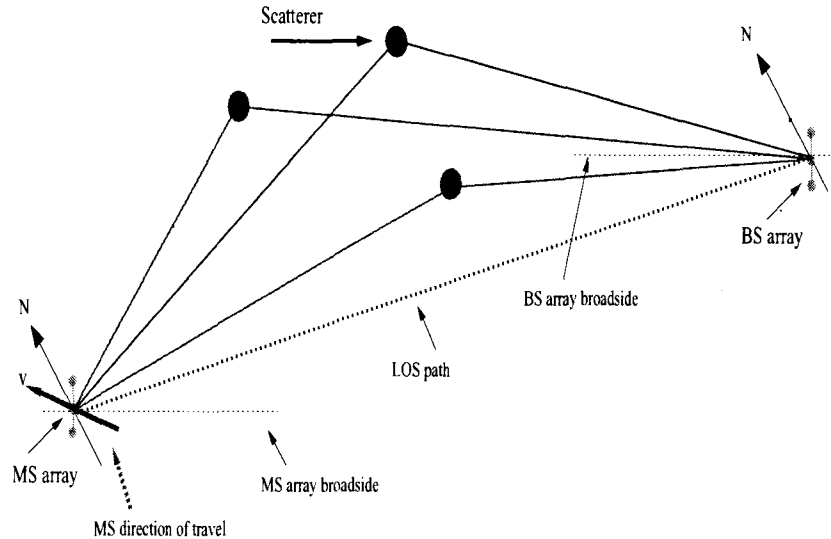

FIGURE 3.1 A BIDIRECTIONAL BEAMFORMING MIMO PROPAGATION CHANNEL MODEL

In order to jointly estimate multipath channel parameters, we shall consider the following conditions on the mobile radio propagation scenario:

- The MIMO multipath environment is modelled by a discrete number of rays, each parameterized by a delay, complex amplitude (path fading), AOA and AOD.
- The training sequence signals are digital sequences that are linearly modulated by known pulse shape functions.
- The parameters such as AODs, AOAs, and DOAs are not changing significantly from each time slot to the next.
- The data transmitted by the antennas is sampled at or above the Nyquist rate.
- The antenna array response has a known structure.

The subspace-based methods such as MUSIC [51] and ESPRIT [49] can achieve high resolution of AOA of received signals. Therefore, they are widely used for parameter estimation with various versions. This motivates us to develop a subspace-based approach for MIMO communication systems to estimate channel parameters in multipath environment.

## 3.2 The System Model

### 3.2.1 The Pulse Shaping Scheme

Just as the array manifold contains the spatial wavefield information, the time manifold contains the temporal pulse-shaping function information. Some commonly used pulse shape functions are the family of raised cosine pulses, given by:

$$g(t) = \left(\frac{\sin(\pi t/T)}{\pi t/T}\right) \left(\frac{\cos(\alpha\pi t/T)}{1 - (2\alpha t/T)^2}\right) \quad (3.1)$$

where  $\alpha$  is the *excess bandwidth* beyond the minimum bandwidth  $\pi/T$  required to transmit without inter-symbol-interference (ISI). Fig. 3.2 shows raised cosine pulses for various excess bandwidths. These pulses satisfy the Nyquist criterion for no ISI, that is, are zero at sampling instants  $kT$ , where  $k$  is any nonzero integer. They are bandlimited to  $|\omega| \leq (1 + \alpha)\pi/T$ , but in time domain they are often truncated.

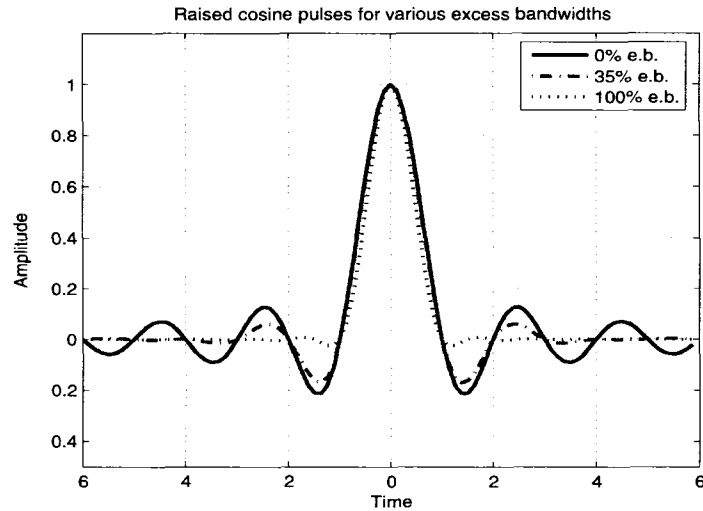

FIGURE 3.2 RAISED COSINE PULSES FOR VARIOUS EXCESS BANDWIDTHS

### 3.2.2 The SIMO Beam-forming Model

In this work, we focus on the case of a single user transmitting modulated digital signal in a specular multipath environment. Digital modulation is the process by which a digital baseband signal is converted into an RF signal for transmission. The digital sequence  $\{x_k\}$  is modulated by the pulse shaping function  $g(t)$ , such that, assuming linear modulation for simplicity, the baseband transmitted signal is the convolution of the digital signal with the modulation waveform:

$$x(t) = \sum_l x_l g(t - lT) \quad (3.2)$$

where  $T$  is the symbol period, and the digital signal is described by a sequence of Dirac pulse  $\sum_l x_l \delta(t - lT)$ .

Let's start with the SIMO case with 1 transmit antenna and  $N$  receiving antenna. The continuous-time received signal at  $n^{\text{th}}$  antenna can be modeled as

$$y_n(t) = \sum_{r=1}^R \beta_r a_{R,n}(\phi_r) a_{T,1}(\theta_r) x(t - \tau_r) + n_n(t) \quad n = 1, 2, \dots, N \quad (3.3)$$

where  $n_n(t)$  is the additive noise.  $\beta_r$  is the amplitude of the multipath signal passing through the  $r^{\text{th}}$  propagation path. The transmit antenna gain at direction  $\theta_r$  is  $a_{T,1}(\theta_r)$ , and the  $n^{\text{th}}$  receive antenna gain at direction  $\phi_r$  is  $a_{R,n}(\phi_r)$ .

Thus, the received signal at the antenna array can be written as an  $N \times 1$  vector  $\mathbf{y}(t)$

$$\mathbf{y}(t) = \sum_{r=1}^R \beta_r \mathbf{a}_R(\phi_r) a_{T,1}(\theta_r) x(t - \tau_r) + \mathbf{n}(t) \quad (3.4)$$

where Gaussian noise  $\mathbf{n}(t)$  has same structure as  $\mathbf{y}(t)$ . The vector  $\mathbf{a}_R(\phi_r) = [a_{R1}(\phi_r), \dots, a_{Rn}(\phi_r)]^T$  is the receive array manifold vector for an ULA array at direction  $\phi_r$ .

In order to derive a formulation for overall channel matrix involving both multipath channel and the pulse shaping filter, we first define a time-invariant channel  $\mathbf{c}(t)$  as (for short intervals),

$$\mathbf{c}(t) = \sum_{r=1}^R \beta_r \mathbf{a}_R(\phi_r) a_{T,1}(\theta_r) \delta(t - \tau_r) \quad (3.5)$$

then the output of the antenna array in a convolution form is

$$\mathbf{y}(t) = \mathbf{x}(t) \star \mathbf{c}(t) + \mathbf{n}(t) \quad (3.6)$$

Thus, by combining the pulse shaping filter  $g(t)$ , the overall channel response can be given by

$$\mathbf{h}(t) = \sum_{r=1}^R \beta_r \mathbf{a}_R(\phi_r) a_{T,1}(\theta_r) g(t - \tau_r) \quad (3.7)$$

It is reasonable to assume that the pulse shape function  $g(t)$  has finite support  $t \in [-\frac{L_g}{2}, \frac{L_g}{2}]$ . If the delay spread  $T_d = M_d T$ , where  $M_d$  is an integer, then Eq. (3.7) implies that the (integer) channel length is  $L$ , where  $LT = L_g T + T_d$ , which means  $\mathbf{h}(t)$  is nonzero only for  $t \in [-\frac{L}{2}, \frac{L}{2}]$ , thus we can write

$$\mathbf{y}(t) = \sum_l x_l \mathbf{h}(t - lT) + \mathbf{n}(t) \quad (3.8)$$

Based on Eq. (3.8), we will derive a discrete time formula of MIMO channel model. Without loss of generality, we suppose that the sampling is perfectly synchronized with the transmission. Collect data over  $K$  symbol periods, and sample at instant  $t = kT$ , Eq. (3.8) becomes

$$\mathbf{y}(kT) = \sum_{l=k-L+1}^k x_l \mathbf{h}(kT - lT) + \mathbf{n}(kT), \quad k = 0, 1, \dots, K-1 \quad (3.9)$$

The channel vectors can be collected into a  $N \times L$  matrix

$$\mathbf{H} = [\mathbf{h}(0) \ \mathbf{h}(T) \ \dots \ \mathbf{h}((L-1)T)]; \quad (3.10)$$

Then based on the channel model (3.7), it follows that

$$\mathbf{H} = [\mathbf{a}_R(\phi_1) \cdots \mathbf{a}_R(\phi_R)] \begin{bmatrix} \beta_1 a_{T,1}(\theta_1) & & & \\ & \beta_2 a_{T,1}(\theta_2) & & \\ & & \cdots & \\ & & & \beta_R a_{T,1}(\theta_R) \end{bmatrix} \begin{bmatrix} \mathbf{g}^T(\tau_1) \\ \mathbf{g}^T(\tau_2) \\ \vdots \\ \mathbf{g}^T(\tau_R) \end{bmatrix} \quad (3.11)$$

where  $\mathbf{g}^T(\tau_r) = [g(kT - \tau_r)]_{k=0,1,\dots,L-1}$  is the  $L$ -dimensional column vector containing the samples of  $g(t - \tau_r)$  defined in last section.

Based on Eq. (3.11), parameter estimation has been proposed to joint DOA and AOA in [63, 64]. In order to estimate these parameters, the channel  $\mathbf{H}$  needs to be determined first. For instance, it can be estimated using least squares methods by collecting training data. For this reason, we write the discrete-time signal model in matrix form as

$$\mathbf{Y} = \mathbf{H}\mathbf{X} + \mathbf{N} \quad (3.12)$$

In Eq. (3.12), the received signal can be written as

$$\mathbf{Y} = [\mathbf{y}_1 \cdots \mathbf{y}_N]^T \quad (3.13)$$

where

$$\mathbf{y}_n = [y_{n,1} \ y_{n,2} \ \cdots \ y_{n,K}]^T$$

and  $\mathbf{N}$  is defined similar to  $\mathbf{Y}$ .

The transmitted signals can be expressed as

$$\mathbf{X} = \begin{bmatrix} x_0 & x_1 & \cdots & x_{K-1} \\ x_{-1} & x_0 & x_1 & \cdots \\ \vdots & \vdots & \vdots & \vdots \\ x_{-L+1} & x_{-L+2} & \cdots & x_{K-L} \end{bmatrix}_{L \times K}$$

### 3.2.3 The MIMO Signal Model

Different from SIMO channel model, additional parameters such as angle of departure will be included. In the MIMO multipath model shown in Fig. 3.1, we assume a MIMO channel employing ULAs (uniform linear array) in both end with  $M$  transmit elements and  $N$  receive elements. There are  $R$  propagating paths, each parameterized by  $\theta_r, \phi_r, \tau_r, \beta_r$ . The parameters  $\theta_r$  and  $\phi_r$  are the departure and arrival angles of the  $r$ th path respectively, while each associated path has a complex path gain  $\beta_r$  and delay  $\tau_r$ .

In order to estimate multipath parameters, we first analyze the MIMO system model. The original data stream  $\mathbf{s}$  is demultiplexed into  $M$  parallel substreams  $\mathbf{d}_m$  ( $m = 1 \cdots M$ ), and each substream is then mapped into symbol substream  $\mathbf{x}_m$ . These symbols in parallel substreams are then transmitted through their respective antennas simultaneously. The signals we sending out are actually electromagnetic waves which convey the same information as the discrete sequence of  $x_m[k]$ .

The digital sequence  $x_m[k]$  is modulated by a pulse shaping function  $g(t)$ . The problem of pulse shaping involves taking a sequence of samples  $x_m[k]$  and converting them into a continuous time waveform  $x_m(t)$  such that the waveform has all its spectral content within the channel bandwidth  $W$  and there is no loss of information (i.e., we have a perfect reconstruction). The baseband transmitted signal  $x_m(t)$  at  $m^{\text{th}}$

antenna can be represented as a convolution of the digital signal with the modulation wave:

$$x_m(t) = \sum_l x_m[l]g(t - lT) \quad (3.14)$$

where  $T$  is the symbol period, and the digital signal is described by a sequence of dirac pulse  $\sum x_{mk}\delta(t - kT)$ .

For the case that different signals sent over the transmit antennas

$$\mathbf{x}(t) = [\mathbf{x}_1(t) \ \mathbf{x}_2(t) \ \cdots \ \mathbf{x}_M(t)]^T \quad (3.15)$$

The continuous-time received signal at  $n^{\text{th}}$  antenna can be modeled as

$$y_n(t) = \sum_{r=1}^R \beta_r a_{R,n}(\phi_r) \sum_{m=1}^M a_{T,m}(\theta_r) \mathbf{x}_m(t - \tau_r) + n_n(t) \quad n = 1, 2, \dots, N \quad (3.16)$$

where  $n_n(t)$  is the additive Gaussian noise.  $\mathbf{a}_T(\theta_r)$  is the corresponding array manifold vector for a signal emitting from the direction  $\theta_r$ . Here  $\mathbf{a}_T(\theta_r) = [a_{T1}(\theta_r), \dots, a_{Tm}(\theta_r)]^T$ .

From Eq. (3.16), by considering  $N$  receiving antennas together, we can define the receive vector as

$$\mathbf{y}(t) = \sum_{r=1}^R \beta_r \mathbf{a}_R(\phi_r) \sum_{m=1}^M a_{T,m}(\theta_r) \mathbf{x}_m(t - \tau_r) + \mathbf{n}(t) \quad (3.17)$$

where  $\mathbf{n}(t)$  is the additive Gaussian noise.

Similar to SIMO case, the channel response to a pulse  $g(t)$  for  $m^{\text{th}}$  transmit antenna can be written as

$$\mathbf{h}_m(t) = \sum_{r=1}^R \beta_r \mathbf{a}_R(\phi_r) a_{T,m}(\theta_r) g(t - \tau_r), \quad m = 1, \dots, M \quad (3.18)$$



By combining Eq. (3.17) and (3.18), the output of antenna array at receive side can be rewritten as

$$\mathbf{y}(t) = \sum_{m=1}^M \sum_l x_{m,l} \mathbf{h}_m(t - lT) + \mathbf{n}(t) \quad (3.19)$$

In the following, we will derive a discrete time beamforming model for MIMO systems based on Eq. (3.19). We first collect data over  $K$  symbol periods, then Eq. (3.19) becomes

$$\mathbf{y}(kT) = \sum_{m=1}^M \sum_{l=k-L+1}^k x_{m,l} \mathbf{h}_m(kT - lT) + \mathbf{n}(kT) \quad k = 0, 1, \dots, K-1 \quad (3.20)$$

By considering  $\mathbf{h}_m(kT - lT)$  in a matrix form, the beamforming channel model (3.18) can be rewritten as

$$\begin{aligned} \mathbf{H}_m &= [\mathbf{a}_R(\phi_1) \cdots \mathbf{a}_R(\phi_R)] \begin{bmatrix} \beta_1 a_{T,m}(\theta_1) & & & \\ & \beta_2 a_{T,m}(\theta_2) & & \\ & & \ddots & \\ & & & \beta_R a_{T,m}(\theta_R) \end{bmatrix} \begin{bmatrix} \mathbf{g}^T(\tau_1) \\ \mathbf{g}^T(\tau_2) \\ \vdots \\ \mathbf{g}^T(\tau_R) \end{bmatrix} \\ &= \mathbf{A}_R(\underline{\phi}) \mathbf{B} \begin{bmatrix} g(0T - \tau_1) a_{T,m}(\theta_1) & \cdots & g((L-1)T - \tau_1) a_{T,m}(\theta_1) \\ \vdots & & \vdots \\ g(0T - \tau_R) a_{T,m}(\theta_R) & \cdots & g((L-1)T - \tau_R) a_{T,m}(\theta_R) \end{bmatrix} \\ &= \mathbf{A}_R(\underline{\phi}) \mathbf{B} \mathbf{Q}_m \end{aligned} \quad (3.21)$$

where  $\mathbf{g}(\tau_r) = [g(kT - \tau_r)]_{k=0,1,\dots,L-1}$  is an  $L$ -dimensional column vector containing

the samples of  $g(t - \tau_r)$ . And the matrix  $\mathbf{B}$  is defined as

$$\mathbf{B} = \begin{bmatrix} \beta_1 & & & \\ & \beta_2 & & \\ & & \ddots & \\ & & & \beta_R \end{bmatrix} \quad (3.22)$$

The matrix  $\mathbf{Q}_m$  is defined as

$$\mathbf{Q}_m = \begin{bmatrix} g(0T - \tau_1)a_{T,m}(\theta_1) & \cdots & g((L-1)T - \tau_1)a_{T,m}(\theta_1) \\ \vdots & & \vdots \\ g(0T - \tau_R)a_{T,m}(\theta_R) & \cdots & g((L-1)T - \tau_R)a_{T,m}(\theta_R) \end{bmatrix}$$

Finally, the complete pulse response of the MIMO channel for M transmit antennas can be conveniently represent as

$$\begin{aligned} \mathbf{H} &= [\mathbf{H}_1, \cdots, \mathbf{H}_M] \\ &= [\mathbf{h}_1(0) \mathbf{h}_1(T) \cdots \mathbf{h}_1((L-1)T), \cdots, \mathbf{h}_M(0) \mathbf{h}_M(T) \cdots \mathbf{h}_M((L-1)T)] \\ &= \mathbf{A}_R(\underline{\phi})\mathbf{B}[\mathbf{Q}_1, \mathbf{Q}_2, \cdots, \mathbf{Q}_M] \\ &= \mathbf{A}_R(\underline{\phi})\mathbf{B}[\mathbf{a}_T(\theta_1) \otimes \mathbf{g}(\tau_1), \cdots, \mathbf{a}_T(\theta_R) \otimes \mathbf{g}(\tau_R)]^T \\ &= \mathbf{A}_R(\underline{\phi})\mathbf{B}[\mathbf{A}_T(\underline{\theta}) \diamond \mathbf{G}(\underline{\tau})]^T \end{aligned} \quad (3.23)$$

where  $\mathbf{G}(\underline{\tau}) = [\mathbf{g}(\tau_1), \cdots, \mathbf{g}(\tau_R)]$ .

In order for parameter estimation, similar to SIMO case, the discrete-time signal model in matrix form can be expressed as

$$\mathbf{Y} = \mathbf{H}\mathbf{X} + \mathbf{N} \quad (3.24)$$

Note  $\mathbf{H}$  contains multiple transmit antennas which is different from SIMO counterpart.

in Eq. (3.24), the received signal can be written as

$$\mathbf{Y} = [\mathbf{y}_1 \ \cdots \ \mathbf{y}_N]^T \quad (3.25)$$

where

$$\mathbf{y}_n = [y_{n,1} \ y_{n,2} \ \cdots \ y_{n,K}]^T$$

and  $\mathbf{N}$  is defined similar to  $\mathbf{Y}$ .

Signals sent over the transmitted antenna can be expressed as

$$\mathbf{X} = [\mathbf{X}_1 \ \mathbf{X}_2 \ \cdots \ \mathbf{X}_M]^T \quad (3.26)$$

where at each transmit antenna

$$\mathbf{X}_m^T = \begin{bmatrix} x_{m,0} & x_{m,1} & \cdots & x_{m,K-1} \\ x_{m,-1} & x_{m,0} & x_{m,1} & \cdots \\ \ddots & \ddots & \ddots & \ddots \\ x_{m,-L+1} & x_{m,-L+2} & \cdots & x_{m,K-L} \end{bmatrix}_{L \times K}$$

### 3.2.4 Considering Oversampling

If we consider the oversampling factor (i.e., at each symbol period we take  $P$  samples of data), then we got the temporal vector as the truncated, delayed, and upsampled impulse response of the pulse shaping filter:

$$\mathbf{g}(\tau_r) = [g(-\tau_r) \ g(-\tau_r + T/P) \ \cdots \ g(-\tau_r + (L-1)T/P)]^T \quad (3.27)$$

Here  $L$  denotes the length of the pulse shaping filter, whereas  $g(\cdot)$  denotes the time-continuous Nyquist pulse shape. The path delay is usually expressed in relative units (i.e., normalized by the symbol period  $T$ ).

The Eq. (3.20) becomes

$$\mathbf{y}(kT) = \sum_{m=1}^M \sum_{l=k-L+1}^k x_{m,l} \mathbf{h}_m(kT - lT) + \mathbf{n}(kT) \quad k = 0, \frac{1}{P}, \dots, K - \frac{1}{P} \quad (3.28)$$

If we collect the channel vectors into a  $N \times MPL$  matrix

$$\tilde{\mathbf{H}} = [\mathbf{h}_1(0) \mathbf{h}_1(\frac{T}{P}) \cdots \mathbf{h}_1((L - \frac{1}{P})T), \dots, \mathbf{h}_M(0) \mathbf{h}_M(\frac{T}{P}) \cdots \mathbf{h}_M((L - \frac{1}{P})T)] \quad (3.29)$$

Then in channel model (3.23),  $\mathbf{g}^T(\tau_r) = [g(kT - \tau_r)]_{k=0,1/P,\dots,L-1/P}$  is an  $PL$ -dimensional column vector containing the samples of  $g(t - \tau_r)$ .

In this case, the MIMO channel (3.23) becomes a  $N \times MPL$ , we then rewrite it into an  $NP \times ML$  matrix, which comes

$$\mathbf{H} = [\mathbf{H}_1 \ \mathbf{H}_2 \ \cdots \ \mathbf{H}_M] \quad (3.30)$$

where

$$\mathbf{H}_m = \begin{bmatrix} \mathbf{h}_m(0) & \mathbf{h}_m(T) & \cdots & \mathbf{h}_m((L-1)T) \\ \mathbf{h}_m(\frac{T}{P}) & \mathbf{h}_m((1+\frac{1}{P})T) & \cdots & \cdots \\ \cdots & \cdots & \ddots & \cdots \\ \mathbf{h}_m((1-\frac{1}{P})T) & \mathbf{h}_m((2-\frac{1}{P})T) & \cdots & \mathbf{h}_m((L-\frac{1}{P})T) \end{bmatrix}_{NP \times L}$$

From Eq. (3.28), we can write

$$\mathbf{Y} = [\mathbf{y}_1(0) \mathbf{y}_1(\frac{T}{P}) \cdots \mathbf{y}_1((1-\frac{1}{P})T), \dots, \mathbf{y}_N(0) \mathbf{y}_N(\frac{T}{P}) \cdots \mathbf{y}_N((1-\frac{1}{P})T)]^T \quad (3.31)$$

where

$$\mathbf{y}_n = [y_{n,1} \ y_{n,2} \ \cdots \ y_{n,K}]^T$$

Here  $\mathbf{X}$  is defined same as (3.26).

### 3.3 The Bidirectional Beamforming MIMO Channel

#### 3.3.1 Channel Estimation

The goal we are pursuing is: given the estimates of the MIMO channel impulse response, estimate the channel parameters such as AOD, AOA, and DOA. In the first step, we will estimate the channel impulse response for the MIMO channel. This can be done by using training sequence (TS) or blindly [4].

Now we consider TS based channel estimation, from Eq. (3.31), we can estimate the channel matrix  $\mathbf{H}$  using a Least Squares (LS) estimator. If  $\mathbf{X}$  is already known, because of training for instance, then the LS estimation of the channel with noise is

$$\hat{\mathbf{H}}_{LS} = \mathbf{Y}\mathbf{X}^\dagger + \mathbf{N}\mathbf{X}^\dagger \doteq \mathbf{Y}\mathbf{X}^\dagger + \mathbf{N}' \quad (3.32)$$

where  $\mathbf{N}$  is the Gaussian white noise satisfying  $E[\text{vec}(\mathbf{N})\text{vec}(\mathbf{N})^H] = \sigma^2\mathbf{I}_{MNPL \times MNPL}$ .  $\mathbf{N}'$  by definition is  $\mathbf{N}\mathbf{X}^\dagger$  and  $\mathbf{X}^\dagger = \mathbf{X}^H(\mathbf{X}\mathbf{X}^H)^{-1}$  denotes the Moore-Penrose pseudo-inverse of  $\mathbf{X}$ .

If we choose the sequence to satisfy the condition in which

$$\mathbf{X}\mathbf{X}^H = N_t\mathbf{I} \quad (3.33)$$

where  $N_t$  is the length of the training sequence, then  $\mathbf{N}' = \frac{1}{N_t}\mathbf{N}\mathbf{X}^H$ .

It is easy to show that

$$E[\text{vec}(\mathbf{N}')\text{vec}(\mathbf{N}')^H] = \frac{\sigma^2}{N_t} \mathbf{I}_{MNPL \times MNPL} \doteq \sigma_e^2 \mathbf{I}_{MNPL \times MNPL} \quad (3.34)$$

where  $\sigma_e^2 = \frac{\sigma^2}{N_t}$ , which will be useful in the Cramer-Rao Lower Bound calculation.

Assume that the transmitted training signal's power is constrained as  $\|\mathbf{X}\|_F^2 = \mathbf{E}$ , where  $\mathbf{E}$  is a given power constant. We can find the optimal signal minimizing the channel mean square error (MSE) based on this constraint, it becomes;

$$\min_{\mathbf{X}} J_{LS} = \min_{\mathbf{X}} E\{\|\mathbf{H} - \hat{\mathbf{H}}_{LS}\|_F^2\} \text{ subject to } \|\mathbf{X}\|_F^2 = \mathbf{E} \quad (3.35)$$

It has been proved that  $\mathbf{X}$  is an optimal training matrix if  $\mathbf{X}\mathbf{X}^H = \frac{\mathbf{E}}{M}\mathbf{I}$ . Therefore, the optimal training signal is any signal with training matrix with orthogonal rows of the same norm  $\sqrt{\frac{\mathbf{E}}{M}}$ .

### 3.3.2 Arrangement of Channel Response for Parameter Estimation

In order to estimate the angle of departure, angle of arrival, and the delay of arrival with knowledge only of the transfer matrix  $\mathbf{H}$ , we can first vectorize the matrix by stacking its columns. Using the *vec* operator, we get from (3.23):

$$\mathbf{h} = \text{vec}(\mathbf{H}) = \mathbf{A}_T(\underline{\theta}) \diamond \mathbf{G}(\underline{\tau}) \diamond \mathbf{A}_R(\underline{\phi}) \mathbf{b} \quad (3.36)$$

where  $\mathbf{b} = [\beta_1 \dots \beta_R]^T$ .

Let us define the space-time response matrix for  $R$  paths as

$$\mathbf{W}(\underline{\theta}, \underline{\phi}, \underline{\tau}) = \mathbf{A}_T(\underline{\theta}) \diamond \mathbf{G}(\underline{\tau}) \diamond \mathbf{A}_R(\underline{\phi}) \quad (3.37)$$

where  $\mathbf{A}_T(\underline{\theta})$  and  $\mathbf{A}_R(\underline{\phi})$  represent array response matrix for transmit and receive side respectively, where  $\mathbf{A}_T(\underline{\theta}) = [\mathbf{a}_T(\theta_1) \dots \mathbf{a}_T(\theta_R)]$ , and the similar definition holds for  $\mathbf{A}_R(\underline{\phi})$ .

Since  $\mathbf{A}_T(\underline{\theta})$ ,  $\mathbf{A}_R(\underline{\phi})$ , and  $\mathbf{G}(\underline{\tau})$  has same number of column, the MIMO space-time manifold vector is the  $r^{th}$  column of  $\mathbf{W}(\underline{\theta}, \underline{\phi}, \underline{\tau})$ , which can be expressed as

$$\mathbf{w}(\underline{\theta}, \underline{\phi}, \underline{\tau}) \doteq \mathbf{a}_T(\underline{\theta}) \otimes \mathbf{g}(\underline{\tau}) \otimes \mathbf{a}_R(\underline{\phi}) \quad (3.38)$$

This MNPL-dimensional vector is the spatial-temporal response to the antenna array to a signal path with AOD ( $\underline{\theta}$ ), AOA ( $\underline{\phi}$ ), and delay ( $\underline{\tau}$ ).

With  $\mathbf{v}$  as the estimated white noise vector, we can rewrite (3.36) into

$$\mathbf{u} = \mathbf{h} + \mathbf{v} = \mathbf{W}(\underline{\theta}, \underline{\phi}, \underline{\tau})\mathbf{b} + \mathbf{v} \quad (3.39)$$

After all, we collect data from  $Q$  consecutive time slots and use it to obtain (noise) estimates of  $\mathbf{H}$ . If we let  $q$  be the time slot index, our estimates  $\mathbf{U}(q)$  of the true channel  $\mathbf{H}(q)$  take the form

$$\mathbf{U}(q) = \mathbf{H}(q) + \mathbf{V}(q), \quad q = 1, \dots, Q \quad (3.40)$$

where  $\mathbf{V}(q)$  is the estimation noise matrix. Applying the  $\text{vec}(\cdot)$  operation yields with the obvious notation,

$$\mathbf{u}(q) = \mathbf{h}(q) + \mathbf{v}(q) = \mathbf{W}(\underline{\theta}, \underline{\phi}, \underline{\tau})\mathbf{b}(q) + \mathbf{v}(q) \quad q = 1, \dots, Q \quad (3.41)$$

Next, letting  $\mathbf{U} = [\mathbf{u}(1) \dots \mathbf{u}(Q)]$ ,  $\mathbf{D} = [\mathbf{b}(1) \dots \mathbf{b}(Q)]$  and similarly for  $\mathbf{V}$ , we obtain

$$\mathbf{U} = \mathbf{W}(\underline{\theta}, \underline{\phi}, \underline{\tau})\mathbf{D} + \mathbf{V} \quad (3.42)$$

The joint parameter estimation problem is, for given channel estimates  $\mathbf{U}$ , to find the  $AOD(\underline{\theta})$ ,  $AOA(\underline{\phi})$ , and  $DOA(\underline{\tau})$  using the model in (3.42). As an aside, note the resemblance of the estimation model to the conventional angle of arrival estimation model

$$\mathbf{Y} = \mathbf{A}(\underline{\theta})\mathbf{X} + \mathbf{N} \quad (3.43)$$

where  $\mathbf{Y}$  is the array output measurements,  $\mathbf{X}$  is the matrix of signals, and  $\mathbf{N}$  is the additive noise. The difference with (3.42) is the following.

1. The “data” are the channel estimates and not the array outputs.
2. The manifold matrix is parameterized by AOD, AOA and DOA.
3. The path fading play the role of the signals.



## CHAPTER 4

### JOINT ESTIMATION OF MULTIPATH PARAMETERS FOR MIMO SYSTEMS

In [34, 55], the multipath signal parameters can be estimated using adaptive array signal processing techniques. Subspace-based methods can achieve high resolution for angle estimation, and can be extended to include other parameters. Joint Angle and Delay Estimation (Jade) algorithms [63, 64] for smart antenna have been proposed for more robust estimation. In a multipath environments, the direction of received signals and associated delays of the path do not change quickly, so that it is possible to estimate these parameters by extending the conventional methods to the joint space and time domain.

With the introduction of the MIMO space time manifold vector, the classical subspace methods, including the deterministic maximum likelihood, stochastic maximum likelihood, and MUSIC can be directly applied. Furthermore, the classical CRB calculation can also be easily extended to the joint space-time model. Therefore, in this research, we propose a subspace-based approach to jointly estimate the AOA, AOD and DOA of digitally modulated multipath signals in MIMO communication system.

#### 4.1 The Proposed Maximum Likelihood Multipath Parameter Estimation Algorithms

The method of ML requires a statistical framework for the data. It can be applied when the data are random variables with a known type of distribution. Their joint likelihood function is computed and maximized over the set of all possible parameters.

The ML estimates of these unknowns are the maximizing arguments of this likelihood function. The rationale is that these values make the probability of having observed the given data as high as possible. Two different assumptions about the path fading lead to corresponding ML approaches (stochastic and deterministic).

#### 4.1.1 The Deterministic Maximum Likelihood (DML) Method

The deterministic approach of the ML technique does not require any assumption about the ray paths. The complex path gains are modelled as arbitrary deterministic sequences although they are unknown (the carrier frequency of the propagating waves over the MIMO channel is known). However the noise term is assumed to be white Gaussian with zero mean as we have seen before.

Since the estimates are assumed independent, their joint likelihood function for  $Q$  time slots is the product of the individual pdf's:

$$P[\mathbf{u}^1, \dots, \mathbf{u}^Q] = \prod_{q=1}^Q (\pi\sigma^2)^{-MNPL} \exp\{-\|\mathbf{u}^{(q)} - \mathbf{W}\mathbf{b}^{(q)}\|^2/\sigma^2\} \quad (4.1)$$

The unknown parameters are the noise variance  $\sigma^2$ , the path parameter  $\underline{\eta} = [\underline{\theta}^T, \underline{\phi}^T, \underline{\tau}^T]^T$  and the fading  $\mathbf{b}^{(q)}$ . The log likelihood function, normalized by  $Q$ , has the form

$$[\sigma^2, \underline{\eta}, \mathbf{b}] = \underset{\sigma^2, \underline{\eta}, \mathbf{b}}{\operatorname{argmax}} \left\{ -MNPL \ln(\pi\sigma^2) - \frac{1}{\sigma^2 Q} \|\mathbf{u} - \mathbf{W}\mathbf{b}\|_F^2 \right\} \quad (4.2)$$

Maximizing w.r.t.  $\sigma^2$  yields

$$\hat{\sigma}^2 = \frac{1}{MNPL} \operatorname{trace}\{\mathbf{P}_u^\perp \hat{\mathbf{R}}_u\} \quad (4.3)$$

where

$$\mathbf{P}_u^\perp = \mathbf{I} - \mathbf{W}(\underline{\phi}, \underline{\theta}, \underline{\tau})[\mathbf{W}^H(\underline{\theta}, \underline{\phi}, \underline{\tau})\mathbf{W}(\underline{\theta}, \underline{\phi}, \underline{\tau})]^{-1}\mathbf{W}^H(\underline{\theta}, \underline{\phi}, \underline{\tau}) \quad (4.4)$$

and

$$\hat{\mathbf{R}}_u = \frac{1}{Q} \sum_{q=1}^Q \mathbf{u}(t_q)\mathbf{u}^H(t_q) \quad (4.5)$$

Thus the DML estimates of channel parameter are obtained by minimizing the cost function

$$[\hat{\underline{\eta}}, \hat{\mathbf{b}}] = \arg \min_{\underline{\eta}, \mathbf{b}} \|\mathbf{u} - \mathbf{W}(\underline{\eta})\mathbf{b}\|_F^2 \quad (4.6)$$

or

$$F(\underline{\theta}, \underline{\phi}, \underline{\tau}) = \text{trace}\{\mathbf{P}_u^\perp \hat{\mathbf{R}}_u\} \quad (4.7)$$

#### 4.1.2 The Stochastic Maximum Likelihood (SML) Method

The stochastic approach of the ML technique assumes the complex path gains to be a stationary, temporally white Gaussian random processes with the following property:

$$E\{\mathbf{b}(t)\} = 0, E\{\mathbf{b}(t)\mathbf{b}^H(t)\} = \mathbf{R}_b, E\{\mathbf{b}(t)\mathbf{v}^H(t')\} = 0 \quad (4.8)$$

The ML estimates of channel parameter are obtained by minimizing the cost function:

$$F(\underline{\theta}, \underline{\phi}, \underline{\tau}) = \ln|\mathbf{R}_u| + \text{trace}\{\mathbf{R}_u^{-1}\hat{\mathbf{R}}_u\} \quad (4.9)$$

where

$$\mathbf{R}_u = \mathbf{W}(\underline{\theta}, \underline{\phi}, \underline{\tau})\mathbf{R}_b\mathbf{W}^H(\underline{\theta}, \underline{\phi}, \underline{\tau}) + \sigma^2\mathbf{I} \quad (4.10)$$

and if  $\sigma^2$  and  $\mathbf{R}_b$  are not known, they can be estimated from  $\hat{\mathbf{R}}_u$ , as defined in Eq. (4.5)

$$\hat{\sigma}^2 = \frac{1}{MNL P - R} \cdot \text{trace}\{[\mathbf{I} - \mathbf{W}\mathbf{W}^\dagger]\hat{\mathbf{R}}_u\} \quad (4.11)$$

$$\hat{\mathbf{R}}_b = \mathbf{W}^\dagger [\hat{\mathbf{R}}_u - \hat{\sigma}^2 \mathbf{I}] \mathbf{W}^{\dagger H} \quad (4.12)$$

where  $\mathbf{W}^\dagger$  indicates the Moore-Penrose Inverse of  $\mathbf{W}$ .

## 4.2 The Proposed Subspace-based Multipath Parameter Estimation Algorithm

The multiple signal classification (MUSIC) method proposed in [51] is a spectral-based algorithm but relies on the properties of the eigenvalue decomposition of the covariance matrix. The divided signal and noise subspace are orthogonal. For MIMO channel, the noise eigenvectors  $\Lambda_n$  are perpendicular to the space-time manifold vector  $\mathbf{w}(\underline{\theta}, \underline{\phi}, \underline{\tau})$  or the signal subspace spanned by  $\Lambda_s$ . Then we have the following orthogonality condition

$$\Lambda_n^H \mathbf{w}(\underline{\theta}, \underline{\phi}, \underline{\tau}) = 0 \quad (4.13)$$

The idea of the algorithm is to find the  $R$  vectors  $\mathbf{w}(\underline{\theta}, \underline{\phi}, \underline{\tau})$  which are the most orthogonal to the estimate of  $\Lambda_n$ .

Let  $\Lambda_1, \Lambda_2, \dots, \Lambda_{MNLP}$  be the eigenvectors of the estimated covariance matrix  $\hat{\mathbf{R}}_u$  arranged in the descending order of the corresponding eigenvalues. The eigenvectors spanning the signal subspace corresponding to the  $R$  largest eigen values will be

$$\hat{\Lambda}_s = [\Lambda_1, \Lambda_2, \dots, \Lambda_R] \quad (4.14)$$

The MUSIC estimation of the channel parameter is to find the  $R$  minima of the following cost function:

$$F(\underline{\theta}, \underline{\phi}, \underline{\tau}) = \mathbf{w}^H(\underline{\theta}, \underline{\phi}, \underline{\tau}) [\mathbf{I} - \hat{\Lambda}_s \hat{\Lambda}_s^H] \mathbf{w}(\underline{\theta}, \underline{\phi}, \underline{\tau}) \quad (4.15)$$

The proposed subspace-based algorithm can be summarized as follows:

1. At each time slot, using training sequence or blindly estimate the channel transfer matrix  $\mathbf{H}$ , then use *vec* operation to yield  $\mathbf{u}$ .
2. Collect data from  $Q$  time slots, then the covariance matrix of  $\mathbf{u}$  can be expressed as Eq. (4.5).
3. Find eigenvalues of  $\hat{\mathbf{R}}_u$ , and arrange them in the descending order, the eigenvectors  $\hat{\mathbf{\Lambda}}_s$  spanning the signal subspace are corresponding to the  $R$  largest eigenvalues.
4. The estimation of the channel parameters is to find the  $R$  minima of the cost function (4.15).

### 4.3 The Cramer-Rao Lower Bound

The CRLB is a lower bound on the variance of any unbiased estimator. We now derive the deterministic CRLB for the proposed MIMO parameter estimates.

Starting with (3.42)

$$\mathbf{u} = \mathbf{W}(\underline{\theta}, \underline{\phi}, \underline{\tau})\mathbf{b} + \mathbf{v} \quad (4.16)$$

where  $E[\mathbf{v}\mathbf{v}^H] = \sigma_e^2 \mathbf{I}_{MNPL \times MNPL}$ .

If we define  $\underline{\eta} = [\underline{\theta}^T, \underline{\phi}^T, \underline{\tau}^T]^T$ , the probability density function of  $\mathbf{U}$  is an i.i.d. Gaussian:

$$L(\mathbf{u}) = \frac{1}{(2\pi)^{MNPL}(\sigma_e^2/2)^{MNPL}} \exp\left\{-\frac{1}{\sigma_e^2}[\mathbf{u} - \mathbf{W}(\underline{\theta}, \underline{\phi}, \underline{\tau})\mathbf{b}]^H[\mathbf{u} - \mathbf{W}(\underline{\theta}, \underline{\phi}, \underline{\tau})\mathbf{b}]\right\} \quad (4.17)$$

The log-likelihood function is

$$\ln L = \text{const} - MNPL \ln(\sigma_e^2) - \frac{1}{\sigma_e^2} [\mathbf{u} - \mathbf{W}(\underline{\theta}, \underline{\phi}, \underline{\tau}) \mathbf{b}]^H [\mathbf{u} - \mathbf{W}(\underline{\theta}, \underline{\phi}, \underline{\tau}) \mathbf{b}] \quad (4.18)$$

Thus the parameter vector can be defined as  $[\sigma_e^2, \mathbf{b}, \underline{\theta}, \underline{\phi}, \underline{\tau}]$ . Let  $\bar{\mathbf{b}} \doteq \text{real}(\mathbf{b})$  and  $\tilde{\mathbf{b}} \doteq \text{imag}(\mathbf{b})$ . Taking derivations of the above these parameters. we have:

$$\frac{\partial \ln L}{\partial \sigma_e^2} = -\frac{MNPL}{\sigma_e^2} + \frac{1}{\sigma_e^4} \mathbf{v}^H \mathbf{v} \quad (4.19)$$

$$\frac{\partial \ln L}{\partial \bar{\mathbf{b}}} = \frac{2}{\sigma_e^2} \text{real}(\mathbf{W}^H \mathbf{v}) \quad (4.20)$$

$$\frac{\partial \ln L}{\partial \tilde{\mathbf{b}}} = \frac{2}{\sigma_e^2} \text{imag}(\mathbf{W}^H \mathbf{v}) \quad (4.21)$$

$$\frac{\partial \ln L}{\partial \theta_r} = \frac{2}{\sigma_e^2} \text{real}(\beta_r^* \mathbf{d}_{\theta_r}^H \mathbf{v}) \quad (4.22)$$

$$\frac{\partial \ln L}{\partial \phi_r} = \frac{2}{\sigma_e^2} \text{real}(\beta_r^* \mathbf{d}_{\phi_r}^H \mathbf{v}) \quad (4.23)$$

$$\frac{\partial \ln L}{\partial \tau_r} = \frac{2}{\sigma_e^2} \text{real}(\beta_r^* \mathbf{d}_{\tau_r}^H \mathbf{v}) \quad (4.24)$$

where  $r = 1, 2, \dots, R$ ,  $\mathbf{d}_{\theta_r}$  is the derivative of the  $r$ th column of  $\mathbf{W}$  and  $\mathbf{d}_{\theta_r} \doteq g(\tau_r) \otimes \mathbf{a}(\phi_r) \otimes d\mathbf{a}(\theta_r)/d\theta_r$ . The similar definition holds for  $\mathbf{d}_{\phi_r}$  and  $\mathbf{d}_{\tau_r}$ . Written more compactly,

$$\frac{\partial \ln L}{\partial \underline{\theta}} = \frac{2}{\sigma_e^2} \text{real}(\text{diag}(\mathbf{b})^H \mathbf{D}_{\theta}^H \mathbf{v}) \quad (4.25)$$

$$\frac{\partial \ln L}{\partial \underline{\phi}} = \frac{2}{\sigma_e^2} \text{real}(\text{diag}(\mathbf{b})^H \mathbf{D}_{\phi}^H \mathbf{v}) \quad (4.26)$$

$$\frac{\partial \ln L}{\partial \underline{\tau}} = \frac{2}{\sigma_e^2} \text{real}(\text{diag}(\mathbf{b})^H \mathbf{D}_{\tau}^H \mathbf{v}) \quad (4.27)$$

where  $\mathbf{D}_{\theta} \doteq [\mathbf{d}_{\theta_1}, \dots, \mathbf{d}_{\theta_R}]$ ,  $\mathbf{D}_{\phi} \doteq [\mathbf{d}_{\phi_1}, \dots, \mathbf{d}_{\phi_R}]$ , and  $\mathbf{D}_{\tau} \doteq [\mathbf{d}_{\tau_1}, \dots, \mathbf{d}_{\tau_R}]$ . Finally, we define  $\mathbf{D}_W \doteq [\mathbf{D}_{\theta}, \mathbf{D}_{\phi}, \mathbf{D}_{\tau}]$  and  $\bar{\mathbf{B}} \doteq \mathbf{I}_{3 \times 3} \otimes \text{diag}(\mathbf{b})$ . Then we arrive at a more compact

form in terms of  $\underline{\eta}$ :

$$\frac{\partial \ln L}{\partial \underline{\eta}} = \frac{2}{\sigma_e^2} \text{real}(\bar{\mathbf{B}}^H \mathbf{D}_W^H \mathbf{v}) \quad (4.28)$$

The Fisher Information Matrix (FIM) involves calculation of the following ensemble averages:

$$E\left[\left(\frac{\partial \ln L}{\partial \sigma_e^2}\right)^2\right] = \frac{MNPL}{\sigma_e^4} \quad (4.29)$$

$$E\left[\left(\frac{\partial \ln L}{\partial \underline{\mathbf{b}}}\right)\left(\frac{\partial \ln L}{\partial \underline{\mathbf{b}}}\right)^T\right] = \frac{2}{\sigma_e^2} \text{real}(\mathbf{W}^H \mathbf{W}) \quad (4.30)$$

$$E\left[\left(\frac{\partial \ln L}{\partial \underline{\mathbf{b}}}\right)\left(\frac{\partial \ln L}{\partial \underline{\mathbf{b}}}\right)^T\right] = -\frac{2}{\sigma_e^2} \text{imag}(\mathbf{W}^H \mathbf{W}) \quad (4.31)$$

$$E\left[\left(\frac{\partial \ln L}{\partial \underline{\mathbf{b}}}\right)\left(\frac{\partial \ln L}{\partial \underline{\mathbf{b}}}\right)^T\right] = \frac{2}{\sigma_e^2} \text{real}(\mathbf{W}^H \mathbf{W}) \quad (4.32)$$

$$E\left[\left(\frac{\partial \ln L}{\partial \underline{\mathbf{b}}}\right)\left(\frac{\partial \ln L}{\partial \underline{\eta}}\right)^T\right] = \frac{2}{\sigma_e^2} \text{real}(\mathbf{D}_W \bar{\mathbf{B}}) \quad (4.33)$$

$$E\left[\left(\frac{\partial \ln L}{\partial \underline{\mathbf{b}}}\right)\left(\frac{\partial \ln L}{\partial \underline{\eta}}\right)^T\right] = \frac{2}{\sigma_e^2} \text{imag}(\mathbf{D}_W \bar{\mathbf{B}}) \quad (4.34)$$

$$E\left[\left(\frac{\partial \ln L}{\partial \underline{\eta}}\right)\left(\frac{\partial \ln L}{\partial \underline{\eta}}\right)^T\right] = \frac{2}{\sigma_e^2} \text{real}(\bar{\mathbf{B}}^H \mathbf{D}_W^H \mathbf{D}_W \bar{\mathbf{B}}) \quad (4.35)$$

Finally, the FIM for the parameter is given by  $E[\underline{\gamma} \underline{\gamma}^T]$ , where  $\underline{\gamma} \doteq \partial \ln L / \partial [\sigma_e^2 \bar{\mathbf{b}}^T \underline{\mathbf{b}}^T \underline{\eta}^T]^T$ .

Directly using results proven in [56], we have

$$CRLB(\underline{\eta})^{-1} = \frac{2}{\sigma_e^2} \text{real}(\bar{\mathbf{B}}^H \mathbf{D}_W^H \mathbf{P}_W^\perp \mathbf{D}_W \bar{\mathbf{B}}) \quad (4.36)$$

where  $\mathbf{P}_W^\perp = \mathbf{I} - \mathbf{W}(\mathbf{W}^H \mathbf{W})^{-1} \mathbf{W}^H$  is the projector onto the noise space.

#### 4.4 Simulation Results and Discussions

In this simulation, we assume a single user, and a two-element ULA at transmitter and a three-element ULA at receiver. The received signal at the MS consists of three time-delayed multipath replicas of the transmitted signal.

The value of multipath parameters in this simulation are given in Table 4.1. The angle unit is degree, and the unit of DOA is second, where  $T$  is normalized to one. The collected data are corrupted by noise with inverse variance  $1/\sigma^2 = 20dB$ . The

TABLE 4.1 VALUE OF MULTIPATH PARAMETERS

Multipaths	First	Second	Third
DOA	0.34T	0.93T	1.77T
AOD	-17	23	65
AOA	7	35	-51

modulation waveform is a raised cosine pulse with excess bandwidth 0.35, assumed to be zero outside the interval  $[-3, 3)$ . We sampled at rate  $T/2$ . Data is collected over 30 time slots, and at each time slot the channel is estimated via Least Square method using 30 training bits. The experiment variance of the angle and delay estimation is computed from 100 runs.

The following figures show simulation results for the proposed spectral based approach.



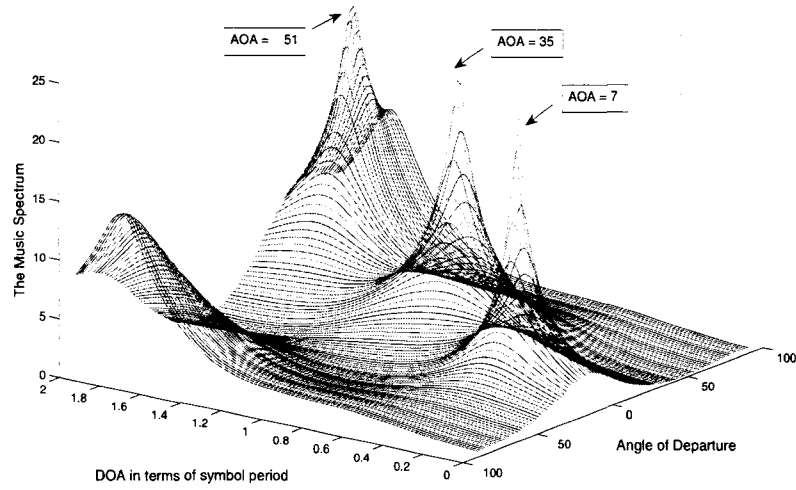

FIGURE 4.1 PLOT OF THE MUSIC SPATIAL SPECTRUM FOR MULTIPATH (AOD vs. DOA)

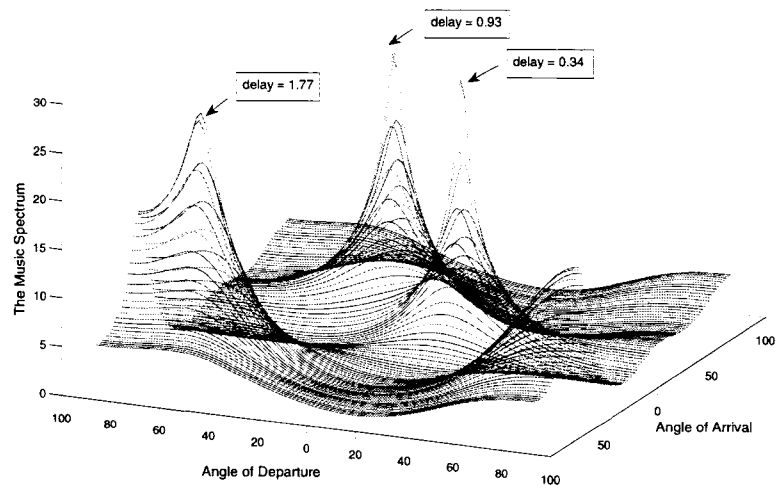

FIGURE 4.2 PLOT OF THE SPATIAL SPECTRUM FOR BIDIRECTIONAL ANGLE ESTIMATION (AOD vs. AOA)

Fig. 4.1 and Fig. 4.2 illustrate the computer simulations of the proposed joint estimation algorithm for MIMO channel that using a two uniformly spaced linear array with half wavelength inter-element spacing at both site. This method is able to distinguish the three multipath signals of equal power. All multipaths parameters can be found in Table 4.1.

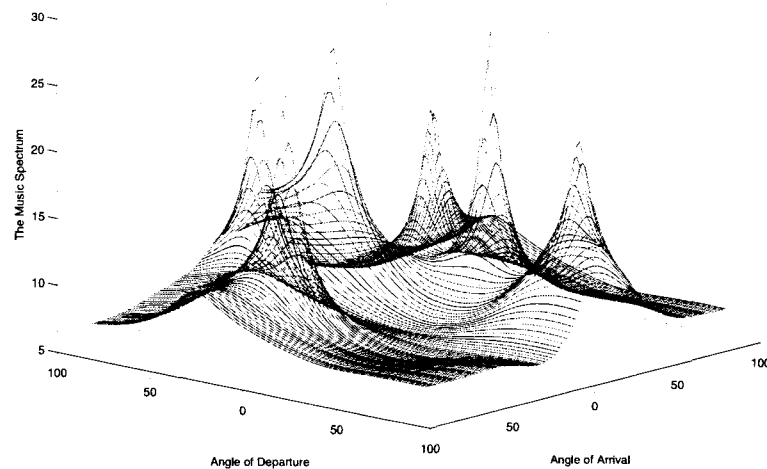

FIGURE 4.3 PLOT OF THE RESOLUTION OF AOA AND AOD ESTIMATION FOR SIX MULTIPATHS

Fig. 4.3 shows that the proposed method can achieve high resolution of multipath parameters and resolve more multipath components than the number of array elements. In this figure, there're six multipath signals can be distinguished using the same ULA configuration as Fig. 4.1.

The RMS value of the spatio-temporal estimates are plotted in Fig. 4.4 and Fig. 4.5 for various SNR's. Only the first two paths are shown-others exhibit similar behavior. They are compared against the deterministic CRLB (??). Fig. 4.4 shows the RMS value of AOA, as well as the RMS value of DOA in Fig. 4.5. The AOD estimates are

found much closer to the AOA estimates.

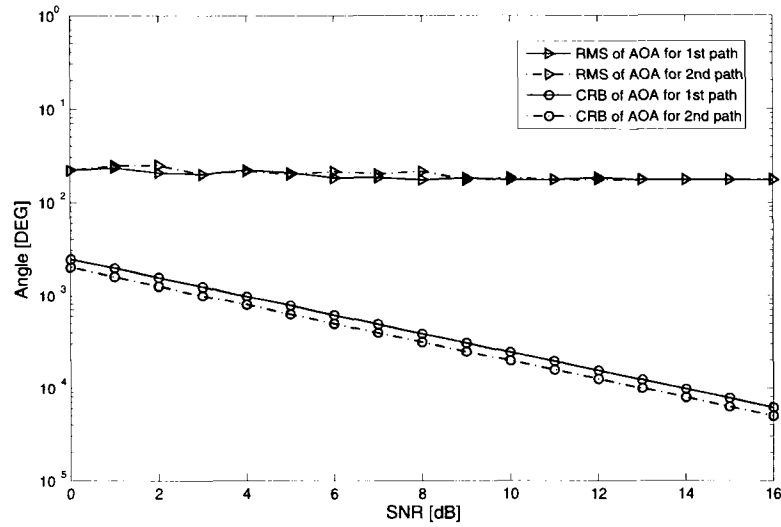

FIGURE 4.4 PERFORMANCE OF THE SUBSPACE-BASED ALGORITHM FOR VARIOUS SNR's (AOA ESTIMATION)

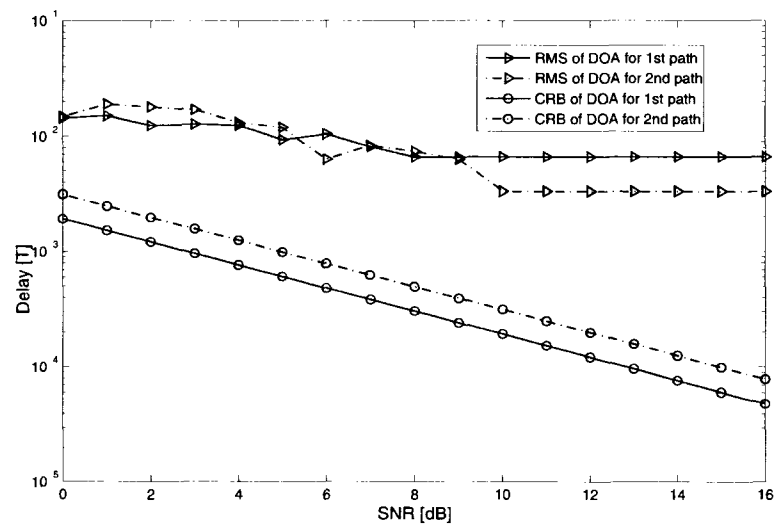

FIGURE 4.5 PERFORMANCE OF THE SUBSPACE-BASED ALGORITHM FOR VARIOUS SNR's (DOA ESTIMATION)

If we consider multiple users in this communication system, we can use each user's unique training sequence which could be orthogonal to each other to independently estimate the channel matrices  $\mathbf{H}$ .

The proposed algorithm for joint estimation of MIMO channel parameters exploits the space time properties of the multipath channel. It has the following advantages:

- If received signals arrive in same direction, the conventional estimation algorithm can not distinguish their difference. But with joint estimation, the two signals with same direction can be separated by their delays.
- Since it's a spectral based algorithm, high-resolution of channel parameters can be achieved even under low SNR.

However, the proposed spectral based approach requires a three-dimension extrema search of the cost function. This search can be performed using dynamic programming or alternate projection methods. But this technique does give us a practical insight into the resolving power of the subspace based approach for MIMO communication systems.

## 4.5 Conclusions

In Chapter 3 and Chapter 4, we first developed a parametric MIMO channel model in multipath environment. By using the fact that the AOA, AOD and DOA are almost constant over several time slots, we then proposed a novel approach to jointly estimate channel parameters for MIMO communication systems. This approach collects estimates of space-time manifold vector through several time slots, then analyze the eigen structure of covariance of MIMO channel transfer function. A high-resolution estimation of multipath parameters can be achieved through subspace based meth-

ods. This method uses a collection of estimates of a space-time manifold vector of the channel, then exploits the eigenstructure of the input covariance matrix. Finally, by searching the peaks of the MUSIC spatial spectrum to estimate the parameters of the multiple incident signals. Cramer-Rao Lower Bound for this approach is also derived to demonstrate the performance of the proposed method. Furthermore, with additional multipath parameters estimated, new source localization methods for mobile terminals or sensors can be developed to reach higher accuracy.

## CHAPTER 5

### POSITION LOCATION OF MOBILE TERMINAL IN MIMO SYSTEMS

#### 5.1 The Proposed Hybrid TDOA/AOA/AOD Location Method for MIMO Systems

The research work on wireless PL systems are mainly based on multilateration solutions which require at least three BSs to estimate the position of Mobile terminal. In MIMO communication systems, since multiple antennas or antenna arrays are utilized in both sides, it can resolve the different propagation paths between a transmitter and receiver by using more advanced array signal processing to exploit more channel information (such as AOD) than smart antenna and point-to-point wireless communication systems. Therefore, new position location method for MIMO systems need to be developed.

With additional AOD information in MIMO system, it is possible to locate the position of mobile terminals by using only one BS in MIMO communication systems. If we estimate the TDOA between the first path and other paths, along with the estimation of the AOA and AOD for each path, a set of nonlinear equations whose solution gives the 2-D coordinates of the source can be defined. As mentioned earlier, solving the set of nonlinear equation can be performed by linearization. Some methods similar to Taylor-series and TSLS solutions can be developed to locate the position of mobile terminal by using only one BS.

The proposed hybrid AOA/AOD/TDOA PL method for MIMO communication systems is different from conventional PL methods in many aspects:

- Both transmitter and receiver sides use antenna array, then the channel model between BS and MS can be treated as MIMO channel.
- Using adaptive array signal processing, the spatial and time properties of the multipath channel will be exploited. The multipath propagation turns into benefit for position location systems.
- Since more parameters(AOA, AOD, DOA) can be exploited in MIMO channel, it is possible to locate the position of mobile terminals by using only one BS in MIMO communication systems.
- The estimation for the location of the mobile terminal can fully utilize hybrid TDOA/AOA/AOD approach to reach higher accuracy.
- The position location seems also possible on Mobile terminal side which is not realistic in conventional PL systems.

### 5.1.1 System Model for Position-Location

The location estimation model for MIMO multipath propagation channel is illustrated in Fig. 5.1. The proposed algorithm intends to minimize the error occurring from the estimation of multiple paths and give an optimal estimation of the MS position by simultaneously calculating a set of nonlinear location equations.

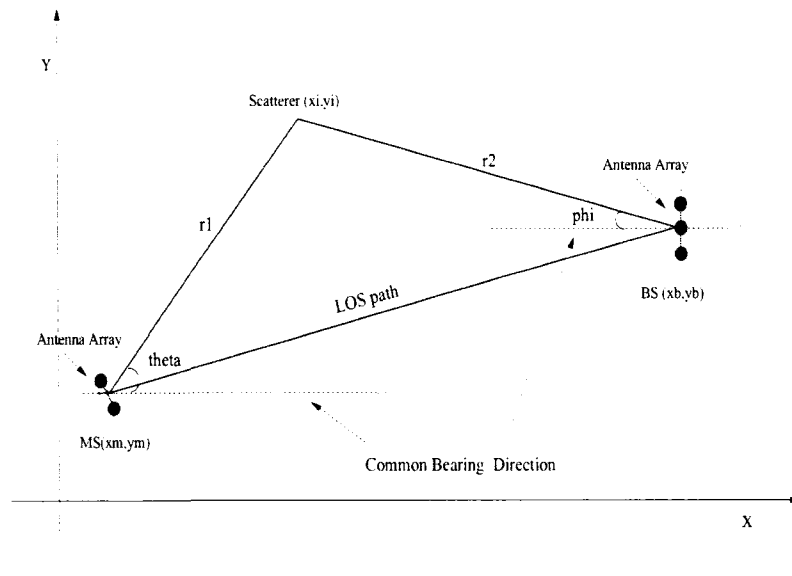

FIGURE 5.1 ILLUSTRATION OF THE  $i$ TH SCATTERED PATH WITH RESPECT TO TRANSMIT AND RECEIVE ANTENNA ARRAY

### 5.1.1.1 Line-of-sight Scenario

If we have a line-of-sight path available, the position of mobile station can be calculated easily, then we will have:

$$\begin{aligned}
 \theta'_i &= \theta_i - \theta_1, & \phi'_i &= \phi_i - \phi_1 \\
 r'_i &= \frac{r_1 \sin \phi'_i}{\sin(\theta'_i + \phi'_i)}, & r''_i &= \frac{r_1 \sin \theta'_i}{\sin(\theta'_i + \phi'_i)} \\
 r_i &= r'_i + r''_i
 \end{aligned} \tag{5.1}$$

where  $\theta_i$  and  $\phi_i$  are the angle of departure and arrival for the  $i$ th path from the mobile station to the base station respectively. The angle  $\theta_1$  and  $\phi_1$  are respectively the AOD and AOA for LOS propagation path. As depicted in Fig. 5.1,  $r_i$  is the total length of the  $i$ th path, while  $r'_i$  and  $r''_i$  are respectively the lengths of the segments forming the  $i$ th path, and  $r_1$  is the LOS distance between MS and BS.



Thus, we have the line-of-sight distance between MS and BS:

$$r_1 = r_{i,1} / \left( \frac{\sin \theta'_i + \sin \phi'_i}{\sin(\theta'_i + \phi'_i)} - 1 \right) \quad (5.2)$$

where  $r_{i,1} = r'_i + r''_i - r_1$  is the relative distance between  $i$ th path and LOS path. And the position of MS will be:

$$\begin{aligned} x_m &= x_b - r_1 \cos \theta_1 \\ y_m &= y_b - r_1 \sin \theta_1 \end{aligned} \quad (5.3)$$

In this case, we found there is only one BS station required to give an estimation of the position of MS, because the multiple antennas or antenna array at MS site provide more information for location position. The conventional trilateration method using multiple BSs is not necessary for MIMO systems.

### 5.1.1.2 Non-Line-of-Sight Scenario

However, in practice, the LOS is not always available or can not be distinguished easily. Moreover, the measurements of DOA, AOA and AOD always contain errors due to the hostile wireless propagation environment. As illustrated in Fig. 5.1, let  $(x_b, y_b)$ ,  $(x_m, y_m)$  and  $(x_i, y_i)$  denote the true position of respectively the BS, the MS and the  $i$ th scatterers. The values of  $(x_m, y_m)$  and  $(x_i, y_i)$  are not known in practice and must be estimated.

From Fig. 5.1, it is straightforward to obtain  $\theta_i$  and  $\phi_i$  as a function of the mobile station and the scatterers:

$$\begin{aligned} \theta_i(x_m, y_m, x_i, y_i) &= \arctan\left(\frac{y_i - y_m}{x_i - x_m}\right) \\ \phi_i(x_m, y_m, x_i, y_i) &= \arctan\left(\frac{y_i - y_b}{x_i - x_b}\right) \end{aligned} \quad (5.4)$$

for  $i = 1, \dots, N$ , where  $N$  is the total number of paths. Similarly, with  $c$  defined as the signal propagation speed, the TDOA can be computed:

$$\tau_i(x_m, y_m, x_i, y_i) = (r_i - r_1)/c, \quad i = 2, \dots, N \quad (5.5)$$

where  $r_i = r'_i + r''_i$  with

$$\begin{aligned} r'_i &= \sqrt{(x_i - x_m)^2 + (y_i - y_m)^2} \\ r''_i &= \sqrt{(x_i - x_b)^2 + (y_i - y_b)^2} \end{aligned} \quad (5.6)$$

The objective is to determine the unknown position  $(x_m, y_m)$  from the exact position  $(x_b, y_b)$  and uncertain measurements of  $\hat{\theta}_i$ ,  $\hat{\phi}_i$  and  $\hat{\tau}_i$  (the time delay between paths are known). These assumptions are realistic as several methods have been recently proposed to measure  $\theta_i$ ,  $\phi_i$  and  $\tau_i$  in MIMO communications [34, 55].

Statistically, the measurement contain errors:

$$\begin{aligned} \hat{\tau}_i &= \tau_i(x_m, y_m, x_i, y_i) + n_{\tau_i} \\ \hat{\theta}_i &= \theta_i(x_m, y_m, x_i, y_i) + n_{\theta_i} \\ \hat{\phi}_i &= \phi_i(x_m, y_m, x_i, y_i) + n_{\phi_i}, \end{aligned} \quad (5.7)$$

where  $i = 1, \dots, N$  for  $\hat{\theta}_i$  and  $\hat{\phi}_i$ ,  $i = 2, \dots, N$  for  $\hat{\tau}_i$ .  $n_{\tau_i}, n_{\theta_i}, n_{\phi_i}$  is the measurement error of TDOA, AOA and AOD respectively.

When the number of path  $N \geq 4$ , then we have  $(3N - 1)$  measurements and  $(2N + 2)$  unknown parameters, and the system is over-determined. It is then possible to apply the Least-Squares method to this nonlinear estimation problem.

### 5.1.2 A Generic Nonlinear Location Estimation Method

The process of location estimation is computing a value for an unknown state vector from a related measurement vector. The value or estimate will in general be in error because of measurement noise and “model” errors. In most estimation problems, knowledge of the probability density function of the state parameter to be estimated was always required prior to the measurement parameter. However, this information is not available in many practical cases. The state parameter to be estimated may not even be a random variable. One approach to such problems is to interpret the lack of knowledge concerning the *a priori* probability density function of the parameter in the sense that the density function is implicitly assumed to be uniform (or approximately so over a very wide range).

However, it is often desirable to use an estimation concept free of such assumptions. The well known maximum likelihood estimate of a parameter is that value which will make a given measurement most likely, i.e., the parameter value which causes the conditional probability density induced on the measurements to have its greatest maximum at the given measurements.

More precisely, let  $\mathbf{x}$  be the state vector to be estimated (in general an  $n$ -vector). Let  $z(i), 1 \leq i \leq k$ , be a sequence of measurements (here we assume each  $z(i)$  is scalar) which are generated by the functional relationship:

$$z(i) = h_i[\mathbf{x}, v(i)], \quad i = 1, \dots, k \quad (5.8)$$

where each  $v(i)$  is representing measurement noise or other random interference which tends to make it possible to infer the true value of  $\mathbf{x}$  from the observation  $z(i)$ . Assuming now that the conditional probability density  $p[z(1), \dots, z(k)|\mathbf{x}]$  is known, or has been derived from Eq. (5.8) and the statistics of  $v(i)$ , we may define the

“likelihood function”:

$$l(\mathbf{x}) \doteq p[z(1), \dots, z(k)|\mathbf{x}] \quad (5.9)$$

where the conditional probability density  $p[z(1), \dots, z(k)|\mathbf{x}]$  is now assumed to have been evaluated at a given received measurement sequence,  $z(1), \dots, z(k)$ .

The ML estimate of  $\mathbf{x}$ , denoted by  $\hat{\mathbf{x}}$ , is now the value of  $\mathbf{x}$  which maximizes  $l(\mathbf{x})$  which was the conditional probability density  $p[z(1), \dots, z(k)|\mathbf{x}]$  evaluated for the given received measurements.

Let the observation noise  $v(i)$  in Eq. (5.8) be additive and represent a zero-mean independent gaussian random sequence. Then we have:

$$z(i) = f_i(\mathbf{x}) + v(i) \quad i = 1, \dots, k \quad (5.10)$$

$$\begin{aligned} E[v(i)] &= 0 \\ E[v(i)v(j)^T] &= \mathbf{Q}(j, i)\Delta(j - i) \end{aligned} \quad (5.11)$$

where  $\mathbf{Q}(j, i)$  is a sequence of known covariance matrices, each covariance matrix representing the covariance among the components of  $v(i)$ .

It is desired to determine the maximum likelihood estimate of the parameter  $\mathbf{x}$ . the likelihood function, i.e. the conditional probability of  $z(1), \dots, z(k)$  given  $\mathbf{x}$  is given by:

$$l(\mathbf{x}) = C \exp -\frac{1}{2} \sum_{i=0}^k [z(i) - f_i(\mathbf{x})]^T \mathbf{Q}^{-1}(i, i) [z(i) - f_i(\mathbf{x})] \quad (5.12)$$

where  $C$  (which involves factors of  $\sqrt{2\pi}$  and  $|\mathbf{Q}(i, i)|$ ) is a constant independent of  $\mathbf{x}$ . From the form of Eq. (5.12), we see that maximizing  $l(\mathbf{x})$  leads to minimizing the

quadratic function:

$$\min_{\mathbf{x}} \sum_{i=1}^k [z(i) - f_i(\mathbf{x})]^T \mathbf{Q}^{-1}(i, i) [z(i) - f_i(\mathbf{x})] \quad (5.13)$$

Let

$$\mathbf{z} = \begin{pmatrix} z_1 \\ \vdots \\ z_k \end{pmatrix}, \quad \mathbf{f}(\mathbf{x}) = \begin{pmatrix} f_1(\mathbf{x}) \\ \vdots \\ f_k(\mathbf{x}) \end{pmatrix}, \quad \mathbf{v} = \begin{pmatrix} v_1 \\ \vdots \\ v_k \end{pmatrix} \quad (5.14)$$

In matrix form:

$$\mathbf{z} = \mathbf{f}(\mathbf{x}) + \mathbf{v} \quad (5.15)$$

If  $\mathbf{f}(\mathbf{x})$  is a linear function,  $\mathbf{f}(\mathbf{x}) = \mathbf{G}\mathbf{x}$ , where  $\mathbf{G}$  is a constant matrix. The operation specified by Eq. (5.13) define the method of weighted least squares for estimating the parameter  $\mathbf{x}$  when the observation consists of a discrete sequence. If  $\mathbf{Q}(i, i)$  was identity matrices, then we would have the ordinary least squares problem. In the ordinary LS problem, we simply choose  $l(\hat{\mathbf{x}})$  such that the expected observation (i.e.,  $z(i) = f_i(\mathbf{x})$  which ignores the noise  $v(i)$ ) comes as close as possible to the actual measurement in LS sense of Eq. (5.13). Thus, when the measurement errors are small, the ML estimator gives a LS solution:

$$\hat{\mathbf{x}} = (\mathbf{G}^T \mathbf{Q}^{-1} \mathbf{G})^{-1} \mathbf{G}^T \mathbf{Q}^{-1} \mathbf{z} \quad (5.16)$$

It was shown above that the method of ML and LS yield the same results in the special case of additive white gaussian noise. Notice that a stochastic optimization problem characterized by ML estimation is in fact replaced by a deterministic optimization problem defined by Eq. (5.13).

For a nonlinear  $\mathbf{f}(\mathbf{x})$ , we have to linearize it in order to determine a reasonably simple

estimator. The most straightforward linearization approach is to use the Taylor Series expansion. Consider a nonlinear state/measurement model in Eq. (5.15), we have measurement  $\mathbf{z}$  and want to estimate  $\mathbf{x}$ . In addition, the  $k$ -dimension vector function  $\mathbf{f}(\cdot)$  is assumed to be defined and “well-behaved” in particular, the first derivatives of  $\mathbf{f}(\cdot)$  components with respect to  $\mathbf{x}$  exists. Let  $\mathbf{x}^*$  be an arbitrary estimate of the true state vector  $\mathbf{x}$ , then a weighted sum of squares of measurement residual  $J$  is defined by:

$$J \doteq [\mathbf{z} - \mathbf{f}(\mathbf{x}^*)]^T \mathbf{Q}^{-1} [\mathbf{z} - \mathbf{f}(\mathbf{x}^*)] \quad (5.17)$$

The objective of this nonlinear Least Squares estimation problem can be described as follows: For the measurement/state model of Eq. (5.15) and for the residual performance index given by Eq. (5.17) with  $\mathbf{Q}^{-1}$ , find that estimator  $\mathbf{x}^*$  for which  $J$  in Eq. (5.17) is minimized.

The solution to this nonlinear problem will be an iterative one using perturbations. More specifically, the global properties of  $\mathbf{f}(\cdot)$  will not be involved - it will be assumed that an initial guess (usually  $\mathbf{x}_0$ ) for the required minimizing value in the problem is in a convergent neighborhood of this minimizing value. Thus, we define:

$$\hat{\mathbf{x}}_{k+1} \doteq \hat{\mathbf{x}}_k + \delta_k, \quad k = 0, 1, \dots \quad (5.18)$$

as an iterative sequence for optimal estimate  $\hat{\mathbf{x}}$ :

$$\hat{\mathbf{x}} = \lim_{k \rightarrow \infty} \hat{\mathbf{x}}_k \quad (5.19)$$

Criteria for stopping the iteration in a finite number of steps will be introduced. For a general  $(k + 1)$ th step in the iteration, the value of the performance index  $J$  in Eq.

(5.17) is:

$$J(\hat{\mathbf{x}}_{k+1}) \doteq [\mathbf{z} - \mathbf{f}(\hat{\mathbf{x}}_{k+1})]^T \mathbf{Q}^{-1} [\mathbf{z} - \mathbf{f}(\hat{\mathbf{x}}_{k+1})] \quad (5.20)$$

Combining Eq. (5.18) and (5.20) gives a perturbation equation in the performance index; i.e., the performance index value changes from  $J(\hat{\mathbf{x}}_k)$  to  $J(\hat{\mathbf{x}}_{k+1})$  if the estimator value is changed from  $\hat{\mathbf{x}}_k$  to  $\hat{\mathbf{x}}_{k+1}$ . A perturbation of  $J(\hat{\mathbf{x}}_{k+1}) - J(\hat{\mathbf{x}}_k)$  results from a perturbation of  $\hat{\mathbf{x}}_{k+1} - \hat{\mathbf{x}}_k = \delta_k$ . These are related by combining the equations:

$$J(\hat{\mathbf{x}}_{k+1}) \doteq [\mathbf{z} - \mathbf{f}(\hat{\mathbf{x}}_k + \delta_k)]^T \mathbf{Q}^{-1} [\mathbf{z} - \mathbf{f}(\hat{\mathbf{x}}_k + \delta_k)] \quad (5.21)$$

Now, we use linear perturbations by retaining only the first-order terms in an expansion for  $\mathbf{f}(\cdot)$ :

$$\mathbf{f}(\hat{\mathbf{x}}_k + \delta_k) \simeq \mathbf{f}(\hat{\mathbf{x}}_k) + \left. \frac{\partial \mathbf{f}}{\partial \mathbf{x}} \right|_{\mathbf{x}=\hat{\mathbf{x}}_k} \delta_k \quad (5.22)$$

we then take that:

$$\mathbf{f}(\hat{\mathbf{x}}_k + \delta_k) \simeq \mathbf{f}(\hat{\mathbf{x}}_k) + \mathbf{A}_k \delta_k \quad (5.23)$$

where the  $m \times n$  matrix  $\mathbf{A}_k$  is defined by:

$$\mathbf{A}_k \doteq \left. \frac{\partial \mathbf{f}}{\partial \mathbf{x}} \right|_{\mathbf{x}=\hat{\mathbf{x}}_k} \quad (5.24)$$

Solving Eq. (5.21) gives the sought-after iterative solution algorithm for the nonlinear least squares problem:

$$\hat{\mathbf{x}}_{k+1} = \hat{\mathbf{x}}_k + (\mathbf{A}_k^T \mathbf{Q}^{-1} \mathbf{A}_k)^{-1} \mathbf{A}_k^T \mathbf{Q}^{-1} [\mathbf{z} - \mathbf{f}(\hat{\mathbf{x}}_k)] \quad (5.25)$$

In a practical application of the iterative algorithm, the iteration would be stopped after a finite number of steps and  $\delta_k$  would not in general be zero. An error is thus introduced into the estimate and is held to acceptable levels with iteration-stopping

criteria discussed in conjunction with applications of iterative least squares in the text.

### 5.1.3 Solution to Hybrid TDOA/AOA/AOD Location Equations

In this section, we derive a location estimator to solve the nonlinear hybrid TDOA/AOA/AOD equations for the MS location. Let  $\mathbf{x} = [x_m, y_m, x_1, y_1, \dots, x_N, y_N]^T$  denote true positions of mobile station and scatterers, and we define  $\mathbf{f}$  the  $(3N - 1)$  column vector valued function according to Eq. (5.4) and (5.5):

$$\mathbf{f}(\mathbf{x}) = \begin{pmatrix} \tau_i(x_m, y_m, x_i, y_i) \\ \vdots \\ \theta_i(x_m, y_m, x_i, y_i) \\ \vdots \\ \phi_i(x_m, y_m, x_i, y_i) \end{pmatrix} \quad (5.26)$$

the estimation model of the unknown  $(2N + 2)$  column vector  $\mathbf{x}$  in the presence of additive Gaussian noise is:

$$\mathbf{z} = \mathbf{f}(\mathbf{x}) + \mathbf{n} \quad (5.27)$$

where  $\mathbf{z} = [\hat{\tau}_i \dots \hat{\theta}_i \dots \hat{\phi}_i]^T$  are  $(3N - 1)$  measurement values [12]. The measurement noise  $\mathbf{n} = [n_{\tau_i} \dots n_{\theta_i} \dots n_{\phi_i}]^T$  is assumed to be a multivariate random vector with an  $(3N - 1) \times (3N - 1)$  positive covariance matrix:

$$\mathbf{Q} = E[(\mathbf{n} - E[\mathbf{n}])(\mathbf{n} - E[\mathbf{n}])^T] \quad (5.28)$$



If the covariance matrix  $\mathbf{Q}$  has zero mean, it can be further expressed as:

$$\mathbf{Q} = \begin{pmatrix} \mathbf{Q}_t & \mathbf{0} & \mathbf{0} \\ \mathbf{0} & \mathbf{Q}_d & \mathbf{0} \\ \mathbf{0} & \mathbf{0} & \mathbf{Q}_a \end{pmatrix} \quad (5.29)$$

where  $\mathbf{Q}_t$  is the covariance matrix for TDOA measurement errors,  $\mathbf{Q}_d$  and  $\mathbf{Q}_a$  are the covariance matrix for AOD and AOA measurement errors respectively.

As shown in Eq. (5.24), we could have the gradient matrix [61]:

$$\mathbf{A}_k = \begin{pmatrix} \frac{\partial f_1(\mathbf{x})}{\partial x_1} & \dots & \frac{\partial f_1(\mathbf{x})}{\partial x_{2N+2}} \\ \vdots & \ddots & \vdots \\ \frac{\partial f_{3N-1}(\mathbf{x})}{\partial x_1} & \dots & \frac{\partial f_{3N-1}(\mathbf{x})}{\partial x_{2N+2}} \end{pmatrix} \quad (5.30)$$

The gradient matrix  $\mathbf{A}_k$  is a  $(3N - 1) \times (2N + 2)$  matrix.

Assume  $\mathbf{A}_k^T \mathbf{Q}^{-1} \mathbf{A}_k$  is nonsingular, similar to Eq. (5.25), the iterative nonlinear LS solution of the location estimator gives the estimated  $\mathbf{x}$  for  $(k + 1)$ th iteration:

$$\hat{\mathbf{x}}_{k+1} = \mathbf{x}_k + (\mathbf{A}_k^T \mathbf{Q}^{-1} \mathbf{A}_k)^{-1} \mathbf{A}_k^T \mathbf{Q}^{-1} [\mathbf{z} - \mathbf{f}(\mathbf{x}_k)] \quad (5.31)$$

Therefore, given a set of measured multipath signal parameters, such as AOD and AOA for each path, TDOA between each pair of paths, along with a previous estimate of the mobile's location and angles of departure and arrival of multipath signals, it is possible to determine values of  $\delta_k = \mathbf{x}_{k+1} - \mathbf{x}_k$ , to update the estimated position of MS and scatterers to more closely approximate the actual value. This process is repeated until the value of  $\delta_k$  becomes smaller than a desired threshold, indicating convergence.

Now, let's summarize the procedure to obtain  $\hat{\mathbf{x}}$  from Eq. (5.31) for the proposed

method as follows:

1. Choose  $\mathbf{x}_0$ , initial guesstimate.
2. Linearize  $\mathbf{f}$  about  $\mathbf{x}_0$  and obtain  $\mathbf{A}_k$  matrix.
3. Compute residuals  $[\mathbf{z} - \mathbf{f}(\mathbf{x}_k)]$  and then compute the  $\hat{\mathbf{x}}$ .
4. Check for the orthogonality condition:  $\mathbf{A}_k^T[\mathbf{z} - \mathbf{f}(\mathbf{x})] |_{\mathbf{x}=\hat{\mathbf{x}}} = \text{orthogonality condition value} = 0$
5. If the above condition is not satisfied, then replace the initial guessed value and repeat the procedure.
6. Terminate the iterations when the orthogonality condition is at least approximately satisfied.

## 5.2 Analysis of the Proposed Location Method for MIMO Systems

Suppose there are  $N(\geq 4)$  multiple paths available between BS and MS with 2D array layout for determining the MS position, we have a set of over-determined nonlinear location equations. Because of measurement errors, the solution is not unique.

### 5.2.1 Cramer-Rao Lower Bound

The CRLB is a lower bound on the variance of any unbiased estimator. We now derive the CRLB for the proposed MIMO Hybrid TDOA/AOA/AOD method. The vector of TDOA/AOA/AOD measurements  $\mathbf{z}$  in Eq. (5.15) is asymptotically zero mean Gaussian with covariance matrix given by  $\mathbf{Q}$ , the conditional probability density

function is:

$$P(\mathbf{z}|\mathbf{x}) = \frac{1}{(2\pi)^{k/2} |\mathbf{Q}|^{1/2}} \exp\left\{-\frac{1}{2}(\mathbf{z} - \mathbf{f}(\mathbf{x}))^T \mathbf{Q}^{-1} (\mathbf{z} - \mathbf{f}(\mathbf{x}))\right\} \quad (5.32)$$

If the MIMO hybrid measurement errors are small so that the bias square is insignificant compared with the variance, the CRLB of  $\mathbf{x}$  is given by [34]:

$$\Phi = \left\{ E\left[ \left( \frac{\partial}{\partial \mathbf{x}} \ln P(\mathbf{z}|\mathbf{x}) \right) \left( \frac{\partial}{\partial \mathbf{x}} \ln P(\mathbf{z}|\mathbf{x}) \right)^T \right] \right\}^{-1} \quad (5.33)$$

From vector calculus, if  $\mathbf{z}$  is a  $K \times 1$  vector and  $\mathbf{A}$  is a  $K \times K$  symmetric matrix, then

$$\frac{d}{d\mathbf{z}} (\mathbf{z}^T \mathbf{A} \mathbf{z}) = 2\mathbf{A} \mathbf{z} \quad (5.34)$$

Thus the partial derivative of  $\ln P(\mathbf{z}|\mathbf{x})$  with respect to  $\mathbf{x}$  is:

$$\frac{\partial}{\partial \mathbf{x}} \ln P(\mathbf{z}|\mathbf{x}) = -\frac{\partial \mathbf{f}^T(\mathbf{x})}{\partial \mathbf{x}} \mathbf{Q}^{-1} (\mathbf{z} - \mathbf{f}(\mathbf{x})) \quad (5.35)$$

Hence,

$$\Phi = \left( \frac{\partial \mathbf{f}^T(\mathbf{x})}{\partial \mathbf{x}} \mathbf{Q}^{-1} \frac{\partial \mathbf{f}(\mathbf{x})}{\partial \mathbf{x}} \right)^{-1} \quad (5.36)$$

where  $\frac{\partial \mathbf{f}(\mathbf{x})}{\partial \mathbf{x}}$  is found to be the true value of  $\mathbf{A}_k$  in Eq. (5.30).

### 5.2.2 Advantages of Proposed MIMO PL Method

The proposed hybrid TDOA/AOA/AOD location method for MIMO communication system exploits the spatial properties of the multipath channel, and then it can resolve more signal parameters than traditional PL methods. It has the following advantages:

1. No time synchronization required: All the propagation time-based PL systems

require precise time synchronization of all involved measuring units. For the proposed method, since only one base station is involved in the position location, the time synchronization is not required.

2. No multilateration: Most position location approaches require measurements at multiple receiving stations. This requirement is counter to the cellular network design that assigns one base station to serve a given user. Our new method uses single base station to perform position location in wireless MIMO communication systems.
3. No LOS signal required: Most PL systems require LOS communication links. However, such direct links do not always exist in reality because of the intrinsic complexity of mobile channels. In this work, the proposed method can not only work perfectly without LOS signal, but also find the LOS signal.
4. Less network traffic for PL system: Since only one base station is required for location estimation, it will generate less location update information in the whole PL system. Thus the overall network traffic related to PL can be reduced. Moreover, PL information collection by the network is facilitated.

### 5.3 Simulations and Results

The performance of the proposed mobile location method for MIMO communication system is investigated by computer simulations. The geometric scatterers arrangement in Fig. 5.2 is used as an example which is a simplified MIMO channel propagation model based on 3GPP standard [1]. In this model, we assume that the signal follow  $N$  paths and that along the  $i$ th path, the signal is only scattered by one obstacle at the planar location  $(x_i, y_i)$ . For the two dimensional array MS and BS layout, we have the BS much higher than the MS and most scatterers. For simplicity, we

assume that the signals and noises are Gaussian random process. The TDOA covariance matrix  $\mathbf{Q}_t$  is similar to [9] which has TDOA variance  $\sigma_t^2$  for diagonal elements and  $0.5\sigma_t^2$  for all other elements. The TDOA estimates are simulated by adding to the actual TDOA's correlated Gaussian random noises with covariance matrix given by  $\mathbf{Q}_t$ . The AOD covariance matrix  $\mathbf{Q}_d$  and the AOA covariance matrix  $\mathbf{Q}_a$  have AOD variance  $\sigma_d^2$  and AOA variance  $\sigma_a^2$  as their diagonal elements respectively.

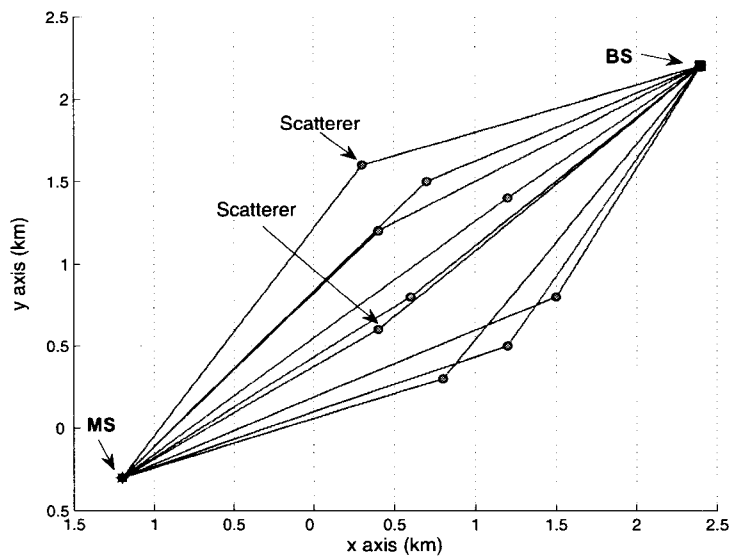

FIGURE 5.2 GEOMETRY ARRANGEMENT OF SCATTERS BETWEEN MS AND BS

The Taylor series estimator is used to derive the MS location. The measured AOD and AOA information are used as initial guess of AOD and AOA, and a location error (about 5 percent of distance between MS and BS) is added to the true MS location as the initial guess of MS position. Simulations show that at most five iterations are required for the Taylor-series solution to converge. A validity test at each step is implemented. We compute  $\det[\mathbf{A}_k^T \mathbf{Q}^{-1} \mathbf{A}_k]$  and reject the input data or the position guess if this number is too small. To detect the failure of convergence, we compute the trace of  $(\mathbf{A}_k^T \mathbf{Q}^{-1} \mathbf{A}_k)^{-1}$  at the end of each iteration, and after five steps or so,

start to compare it with that of the previous step. If the ratio is not much less than unity, the process is not converging. The squared error of MS location estimation is derived at the end of iteration, as a useful check on the validity of the solution. The MSE or RMS location error is obtained from the average of 10,000 independent runs. For each simulation run, the noise corrupted measurements are used where the noises are generated according to the standard deviation of TDOA, AOA and AOD. The iterative computation time of each simulation run is less than 0.01 second.

The position of all scatterers are given in Table 5.1 with MS at position  $(-1.2, -0.3)$ , and BS at position  $(2.4, 2.2)$ . The distance unit is 1km in this work.

TABLE 5.1 POSITIONS OF ALL SCATTERERS

$N$	1	2	3	4	5	6	7	8	9	10
x	0.7	0.3	1.5	0.4	1.2	0.8	1.2	0.4	0.3	0.6
y	1.5	1.6	0.8	0.6	1.4	0.3	0.5	1.2	0.3	0.8

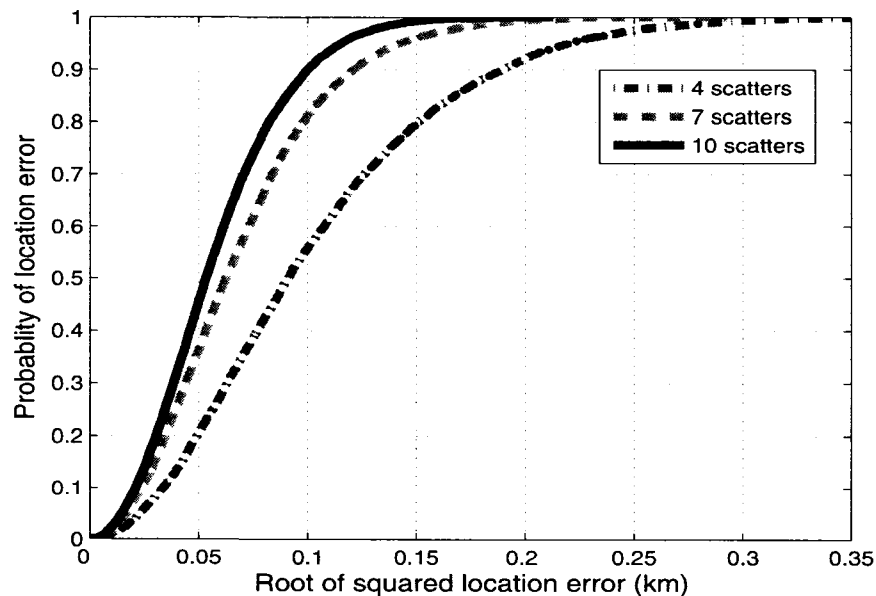

FIGURE 5.3 ROOT OF SQUARED LOCATION ERROR WITH DIFFERENT SCATTERERS' GEOMETRY ARRANGEMENT

In Fig. 5.3, the root value of squared location error estimations are compared as the number of scatterers increases from 4 to 10. The TDOA noise standard deviation is set to be  $0.02/c$ , whereas the AOD and AOA noise standard deviation is 0.3 degrees and 0.1 degrees respectively. It is clear that the proposed method performs better with more scatterers since there are more location equations than unknown parameters. For example, if  $N = 4$ , we have 11 location equations and 10 parameters to estimate; however, as  $N = 10$ , we have 29 location equations and 22 parameters to estimate. Thus, the performance improvement introduced by additional scatterers is significant.

Table 5.2 compares the RMS location errors with the CRLB. The first two diagonal elements from Eq. (5.36) are used to compute the CRLB for MS location estimation. The standard deviation of TDOA, AOA and AOD are the same as Fig. 5.3. From the results, we can see that the position of MS can be estimated with high accuracy, and RMS error estimation of the proposed method approaches the CRLB very closely.

TABLE 5.2 COMPARISON OF RMS ERROR WITH CRLB

Multipaths	RMS (km)	CRLB (km)
N = 4	0.14479	0.11869
N = 5	0.09775	0.08781
N = 6	0.07254	0.06147
N = 7	0.06214	0.05319
N = 8	0.06082	0.05247
N = 9	0.04667	0.04398
N = 10	0.04319	0.04100

Fig. 5.4 illustrates the distribution of squared error estimation for 20,000 runs. The TDOA noise standard deviation is set to be  $0.02/c$ , whereas the AOD and AOA noise standard deviation is 0.3 degree and 0.1 degree respectively.

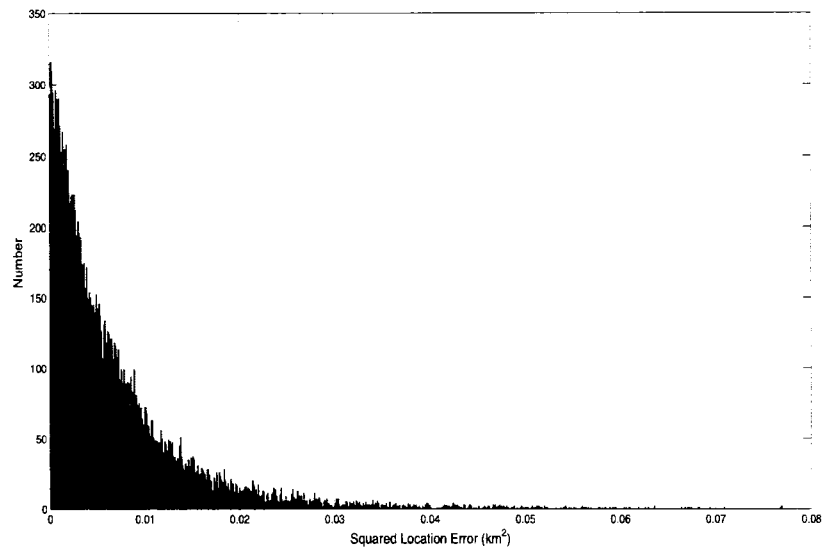

FIGURE 5.4 THE DISTRIBUTION OF SQUARED ERROR

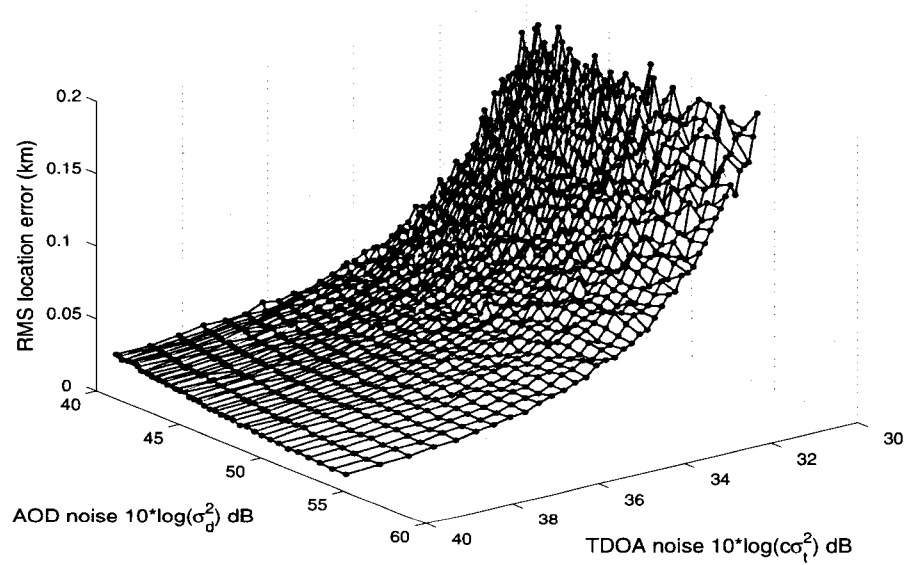

FIGURE 5.5 MEAN SQUARE ERROR WITH DIFFERENT TDOA AND AOD NOISE MEASUREMENT



In Fig. 5.5, we show a 3D illustration of the RMS estimation with different TDOA and AOD noise measurement, whereas the AOA noise standard deviation is set to be 0.1 degree. The simulation results show that the maximum value of RMS is lower than 200m.

The CRLB is also derived in Eq. (5.36) for the proposed location method. In Fig. 5.6, we show a 3D illustration of the Cramer-Rao lower bound with different TDOA and AOD noise measurement, whereas the AOA noise standard deviation is set to be 0.1 degree.

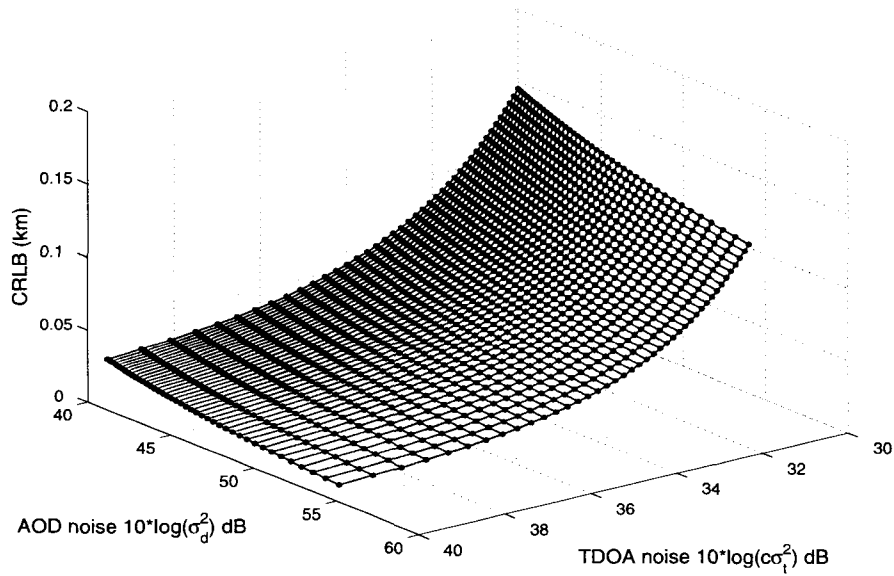

FIGURE 5.6 CRAMER-RAO LOWER BOUND WITH DIFFERENT TDOA AND AOD NOISE MEASUREMENT

#### 5.4 Statistic Results for Geometric Dilution Model

In this section, in order to investigate the effect of various positions of scatterers on the performance of the proposed MIMO location method, we simulate a geometric

dilution model to give some statistical results on the performance of the proposed MIMO location method.

In this simulation, the positions of scatterers are uniformly generated in a square area according to the geometric dilution model shown in Fig. 5.7. The mobile and base station are at a distance  $D = 1$  which is taken as our unit. The scatterers are drawn uniformly in a square domain of center C of coordinates  $(.7, 0)$  and sides  $d_x = d_y = 1$ .

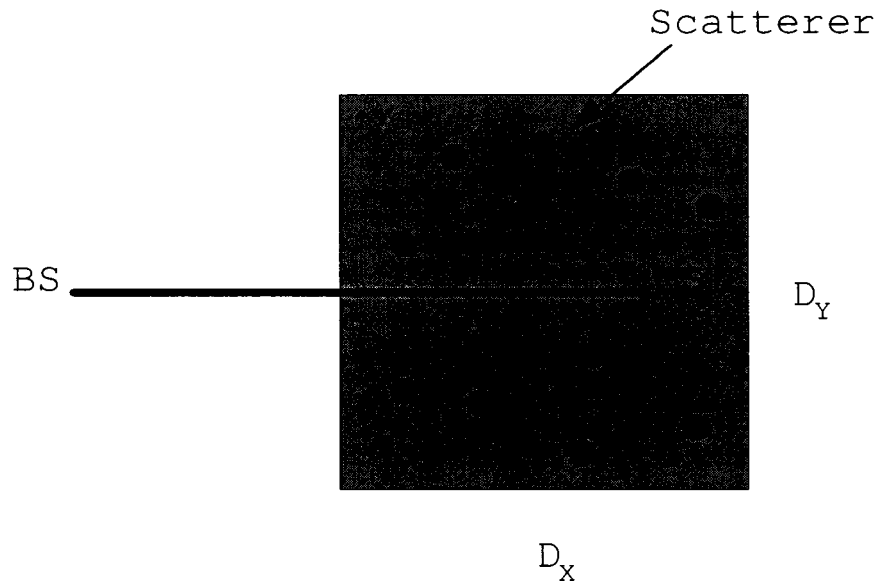

FIGURE 5.7 GEOMETRIC DILUTION MODEL FOR SCATTERING

The Monte Carlo simulation will determine the mean square error distribution of the position measurement for a variable number of scatterers of different positions. For each Monte Carlo simulation run, we randomly choose  $M$  scatterers in the scattering domain. We then calculate the squared location error based on Gaussian random noise. The root mean squared location error is calculated for at least 1000 Monte Carlo simulation runs. We repeat the simulation for a variable number of scatterers  $M$  ( $M = 4 \sim 10$ ). For the noise measurement, the TDOA noise standard deviation is set to be  $0.02/c$ , whereas the AOD and AOA noise standard deviation is 0.3 degree

and 0.1 degree respectively.

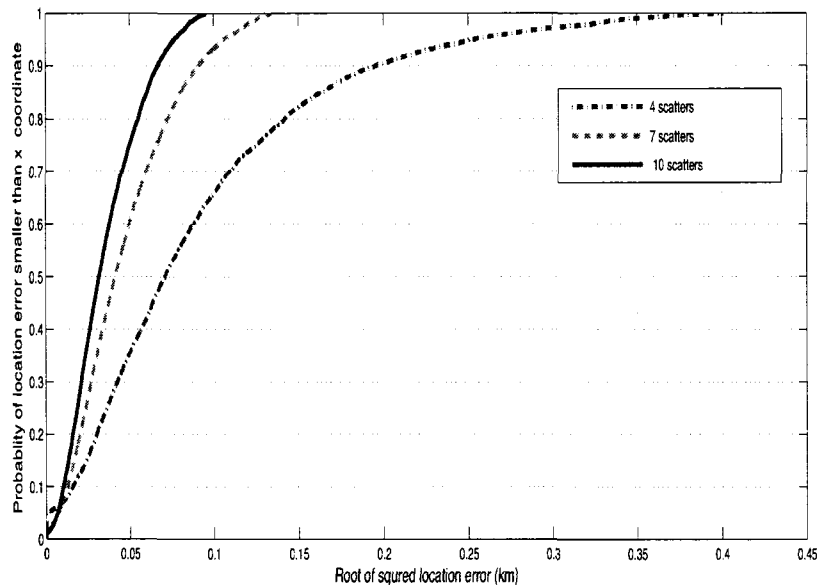

FIGURE 5.8 CUMULATIVE DISTRIBUTION OF RSE LOCATION ERROR

In Fig. 5.8, we show the cumulative distribution of root of squared location error (RSE). Ordinate x is the RSE location error, while ordinate y shows the probability of value less than ordinate x (ordinate  $y \leq$  ordinate x).

For Fig. 5.9, the squared location errors are used as the x-coordinate. Seven scatters are used in this simulation. For the noise measurement, the TDOA noise standard deviation is set to be  $0.02/c$ , whereas the AOD and AOA noise standard deviation is 0.3 degree and 0.1 degree respectively. The x ordinate shows the value of SE (not RSE) location error, whereas the y ordinate shows the number of runs with results falls into certain range. If  $D = 1km$ , we found that the simulated results meet the FCC regulation for E911 service, which require 100 meters for 67 percent of calls, and 300 meters for 95 percent of calls.

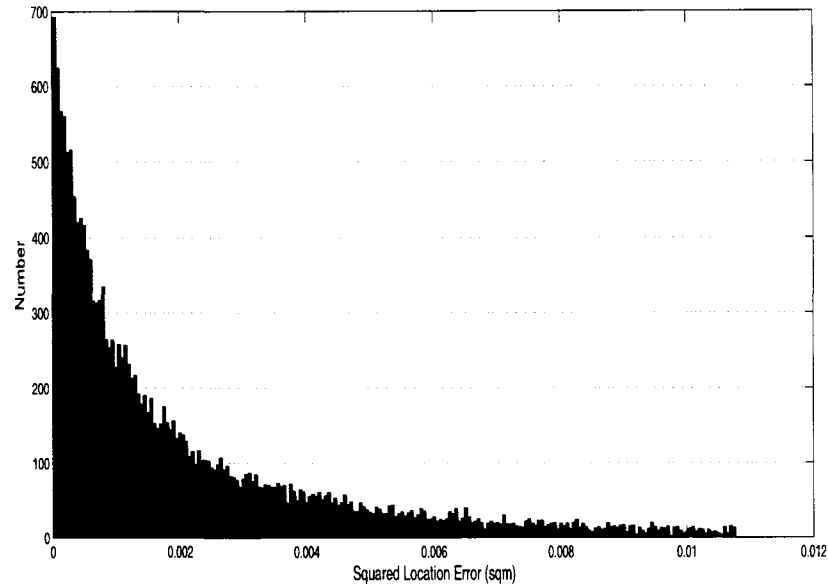

FIGURE 5.9 DISTRIBUTION OF SQUARED LOCATION ERRORS

## 5.5 Conclusions

For the network-based mobile location systems, basic location estimates such as time difference of arrival (TDOA), angle of arrival (AOA) are usually used in accuracy improvement for location methods. However, for conventional location methods, multi-lateration of several BSs are required to give location estimation. In this work, we proposed a novel position location estimation method for MIMO communication systems. The advantage of MIMO systems is to use multiple antennas in both side, thus multipath will be utilized to enhance overall performance of wireless communication. Moreover, it is also possible to estimate more parameters of multipath signals such as AOA, AOD and TDOA.

Using measured multipath signal parameters in MIMO systems, such as TDOA between each pair of path, and AOD and AOA for each path, an over-determined system

can be established with a set of nonlinear location equations. The proposed hybrid TDOA/AOA/AOD location method utilizes Taylor-series linearization to give an iterative nonlinear LS solution. With an initial guess of the mobile's position, the least-squared difference between true MS position and previous estimation of MS position will be minimized. This process is repeated iteratively until the difference falls under a desired threshold. The performance of the proposed method has been evaluated through computer simulation. The Cramer-Rao Lower Bound is also derived.

This method is able to determine the position of the mobile terminal so as to minimize the measurement noise by using a single base station. It might be a revolution for location-position problems by taking full advantage of the power of MIMO communication system for multipath dispersion. Since MIMO communication would be a must for next generation mobile communication systems, this method can be applied in many areas such as mobile devices and sensor position-location problems.

## CHAPTER 6

### CONCLUSIONS AND FUTURE WORK

#### 6.1 Review of Main Contributions

In this work, we have developed a complete new method for position location of mobile terminal in wireless MIMO systems. The focus has been on the joint parameters estimation of multipath propagation channel and position location method of the mobile terminal. The proposed methods have the advantages that the multipath effect has been utilized, thus only one BS is needed to determine the position of MS.

The first part of this dissertation aims at working out some algorithms for the joint estimation of the physical parameters of MIMO channels. Based on a simplified 3GPP MIMO channel models, a bidirectional MIMO multipath propagation channel model is developed. The parameters of interest are the AOA, AOD, DOA and the path gain of each path component. We assume these parameters do not change quickly from each time slot to the next.

By extending the classical parameter estimation methods to the joint space and time domain, the parameters such AOA, AOD and DOA of digitally modulated multipath signals have been jointly estimated in MIMO communication systems. In this work, modified subspace based parameter estimation method is used to achieve high resolution of multipath signal parameters. The novel approach uses a collection of estimates of a space-time manifold vector of the channel which utilizes a Khatri-Rao product to transfer the estimated channel response matrix to the classical model. The proposed algorithms have been evaluated through computer simulation. The Cramer-Rao lower bound on the variance of the parameters's error is also derived,

and compared with the simulation results. The identifiability analysis of the proposed parameter estimation method is also provided.

The estimated multipath signal parameters can be utilized to determine the position of mobile terminal. We then developed a system model for position location, both LOS and NLOS scenario are considered. With this single bounce model, there are  $N$  resolvable propagation paths between the transmitter and the receiver sites, and whereas each scatterer has single reflected signal. Each path is delayed according to its excess delay, and each angle of departure is connected to the corresponding angle of arrival.

In this work, we developed a novel method to use these parameters to build a geometric reconstruction and to localize mobile phone using only one base station in wireless cellular network. By using a set of measured multipath signal parameters, such as TDOA between pairs of paths, and AOD, AOA for each path, it is possible to estimate the position of the mobile terminal so as to minimize the effect of the measurement noise.

For the proposed method, it is not necessary to have a LOS path available. When the number of multipaths  $N$  is greater than 3, we have  $3N - 1$  measurements and  $2N + 2$  unknown parameters, hence the system is over-determined yielding a nonlinear estimation problem. To solve the nonlinear hybrid TDOA/AOA/AOD location equations, the proposed solution uses an iterative Least Squares method combined with Taylor series linearization.

In this way, this approach minimizes the errors occurring from the estimation of multipath parameters and gives the position of the mobile terminal by simultaneously resolving a set of algebraic location equations. The RMS errors are measured and compared with the Cramer-Rao lower bound to demonstrate the performance of the proposed method. This solution breaks the bottleneck of conventional mobile

positioning systems which have to require multi-lateration of at least three BSs. The proposed location method took advantage of multipath effect of signal propagation and worked perfectly under NLOS scenario.

Since more multipath signal parameters can be resolved in MIMO communication systems, the proposed hybrid TDOA/AOA/AOD location method can fully take advantage of the information richness of MIMO systems due to multipath dispersion. We outline the following advantages due mostly to the fact that single base station is involved:

1. The time synchronization is straightforward, and furthermore, PL information collection by the network is facilitated.
2. Most PL systems require LOS path which do not always exist in practice. Our method does not need this requirement. In fact, it will even find the LOS path in that case.
3. Ideal for peer to peer network architecture.

To summarize, in this dissertation, we have proposed a novel approach to determine the position of mobile terminals based on estimated multipath signal parameters using only one base station in the context of MIMO communication systems. The problem of conventional PL methods in terms of time synchronization, multipath effect and NLOS can be solved using the proposed location method. This PL method can be potentially used in many applications as shown below:

- Sensor networks: using single sensor to locate other sensors. Furthermore, routing protocol for sensor network can be greatly improved.
- Medical: remote sensing; ultrasonic positioning; biomedical device for the seeing and hearing impaired.



- Military: radar tracking, signal detection and estimation.
- Safety: This solution allows to localize accurately a device even in densely populated urban environment.

## 6.2 Future Directions

Some aspects might be important and can be extended for the future research work:

### **Joint Parameter Estimation Using Unitary ESPRIT Algorithm**

Due to its simplicity and high performance, ESPRIT has become one of the most powerful subspace-based techniques for AOA or frequency estimation schemes. For certain array geometries, namely centro-symmetric arrays, an ESPRIT-type algorithm has been formulated to reduce the computational complexity significantly. The resulting algorithm is called Unitary ESPRIT [23]. This algorithm has been extended to two, three, and multidimensional cases [22]. Some theoretical elements are presented in [24] and a thorough description of the Multidimensional extension of Unitary ESPRIT is presented in [25]. Since the algorithm deals with the shift invariance in the space frequency domain, which is provided by the antenna configuration, we expect that the antenna to have certain doublets or shift invariance properties found in the classical ESPRIT method. At the same time, the DFT of the channel estimation provides the shift invariant property other DOA in the frequency domain, which allows the algorithm to jointly estimate the AOA and DOA. The elegant spatial smoothing and forward-backward averaging methods are also included in the algorithm. This eliminates the rank deficiency of the channel estimation for cases where the AOAs or DOAs are the same for different multipath components. Therefore, a close-formed subspace-based approach using Unitary ESPRIT technique can be proposed to jointly estimate the AOA, AOD and DOA of digitally modulated multipath signals in MIMO

communication systems.

### **Diffuse paths**

We have assumed a specular multipath environment in this work. That is, the multipath signal path is modelled by a discrete number of rays, each parameterized by a delay, complex amplitude (path gain), angle of arrival and angle of departure. An interesting extension is the case of diffuse paths.

Depending on the nature of the reflection and scattering in many propagation environments, signal components of one source arriving from different directions exhibit varying degrees of correlation, ranging from totally uncorrelated to fully correlated cases. Because spatially-spread sources widely appear in many engineering applications, it is important to develop estimation and detection algorithms to extract signals and parameters of these spatially-spread sources. This leads to so called parametric distributional model, several algorithms (such as COMET, DSPE, DSF/WPSF) for smart antenna systems have been developed to estimate the value of parameters of spatially-spread sources [11, 32]. How to extend these solutions to MIMO systems is an interesting subject of future research.

### **To modify the propagation channel model to meet practical environment**

In this dissertation, a single bounced scattering model for wireless PL system has been proposed, as depicted in MIMO multipath propagation channel model of Fig. 3.1. In the next stage, we can develop a two bounce model where there are scatterers distributed in a circle near the MS. This assumption is close to the Jake's propagation model, but we also consider the far-field scattering point for the second bounce between BS and MS.

### **A new algorithm for 3D mobile position systems**

One assumption in most existing researches is that the MS and BS are located in the same plane. The location to be determined is two-dimensional. Therefore, the effect of BS antenna height is not considered. However, in a real radio propagation environment, the elevation angle of received signal should be considered especially when the MS is inside a high-rise building, or traveling in a hilly terrain area. Hence, a three-dimensional location estimation scheme has to be developed.

### **Mobile location in MIMO communication systems using learning machine**

Due to unavoidable background noise and measurement error, it is very hard to accurately obtain the MS location based on the measurements. To tackle this difficulty, we can use machine learning approach to handle the problems related to uncertainty and imprecision. Learning approach is especially suitable when the relationship between measurements and the object is too complicated to be solved analytically. For example, the nearest neighbor regressor can be adopted as the learning machine to estimation the highly nonlinear relationship between the multipath signal parameters and the mobile terminal position.

### **Extending the proposed method to MIMO-OFDM systems.**

MIMO systems combined with OFDM has received a great deal of attention due to its great potential in achieving high data rates in wireless communications [6]. The main motivation for using OFDM in a MIMO channel is the fact that OFDM modulation turns a frequency-selective MIMO channel into a set of parallel frequency at MIMO channels. This renders multi-channel equalization particularly simple, since for each OFDM-tone only a constant matrix has to be inverted [5, 47].

In MIMO-OFDM systems, the received signal has the same structure as in Eq. (3.24). For pilot-based channel estimation,  $K$  subcarriers are used to carry pilot symbols. Therefore, for channel estimation purposes, the received signal can be collected into a

$N \times K$  matrix  $\mathbf{Y}$  that contains the frequency domain samples received over the pilot subcarriers. Matrix  $\mathbf{H}$  is the  $N \times ML$  MIMO-FIR (time-domain) channel matrix defined as in (3.24). The  $ML \times K$  matrix  $\mathbf{X}$  in this case is no longer a convolution matrix but is the product of a matrix that perform NM Discrete Fourier Transforms on the time domain channels in  $\mathbf{H}$  and a block-diagonal matrix that gathers the pilot symbols transmitted by the  $M$  transmitting antennas. In this way, a parametric estimator can benefit from a joint estimate of the channels for all the transmitting antennas. Therefore, estimation of multipath signal parameters in MIMO-OFDM systems remains an open research direction.

## BIBLIOGRAPHY

- [1] "Spatial channel model for Multiple Input Multiple Output (MIMO) simulations," 3GPP TR 25.996 V6.1.0, Sep. 2003.
- [2] I. K. Adusei, I. K. Kyamakya, K. Jobmann, "Mobile positioning technologies in cellular networks: an evaluation of their performance metrics," in *Proc. MILCOM 2002*, vol. 2, pp. 1239-1244, Oct. 2002.
- [3] D. Bartlett, "Hearability analysis for OTDOA positioning in 3G UMTS networks," *CPS white paper CTN-2002-4-V1.0*, <http://www.cursor-system.com/>.
- [4] M. Biguesh and A.B. Gershman, "MIMO Channel Estimation: Optimal Training and Tradeoffs Between Estimation Techniques," in *Proc. 2004 IEEE International Conference on Communications*, vol. 5, pp. 20-24 June 2004.
- [5] H. Bolcskei, D. Gesbert, and A. J. Paulraj, "On the capacity of OFDM-based spatial multiplexing systems," *IEEE Trans. Commun.*, vol. 50, no. 2, pp. 225-234, Feb. 2002.
- [6] N. Boubaker, K.B. Letaief, and R.D. Murch, "A low complexity multicarrier BLAST architecture for realizing high data rates over dispersive fading channels," in *Proc. IEEE VTC*, vol. 2, May 2001.
- [7] J. Caffery Jr. and G.L. Stuber, "Overview of radiolocation in CDMA cellular systems," *IEEE Communications Magazine*, vol. 36, no.4, pp. 38-45, April 1998.
- [8] J. Caffery Jr. and G.L. Stuber, "Subscriber location in CDMA cellular networks," *IEEE Trans. on vehicular technology*, vol.47, no.2, pp.406-416, May 1998.

- [9] Y. T. Chan and K.C.Ho, "A simple and efficient estimator for hyperbolic location," *IEEE Trans. on Signal Processing*, vol. 42, No.8, pp.1905-1915, Aug. 1994.
- [10] P. C. Chen, "A non-line-of-sight error mitigation algorithm in location estimation," in *Proc. IEEE Wireless Communications Networking conference*, vol. 1, pp. 316-320, 1999.
- [11] I. Chiba, R.Yonezawa, R. Kihira, "Adaptive array antenna for mobile communication," in *Phased Array Systems and Technology, 2000. Proceedings. 2000 IEEE International Conference on*, pp. 109-112, May 2000.
- [12] L. Cong and W. Zhuang, "Hybrid TDOA/AOA mobile user location for wide-band CDMA cellular systems," *IEEE Trans. on Wireless Communications*, vol. 1, pp. 439-447, Jul. 2002.
- [13] L.Cong and W. Zhuang, "Non-line-of-sight error mitigation in TDOA mobile location," in *Proc. IEEE Globecom*, pp. 680-684, Nov. 2001.
- [14] D. Gesbert, H. Bolcskei, D.A. Gore, and A.J. Paulraj, "Outdoor MIMO wireless channels: models and performance prediction," *IEEE Trans. Commun.*, vol. 50, pp. 1926-1934, Dec. 2002.
- [15] D. Gesbert, H. Bölcskei, D. Gore, and A. Paulraj, "MIMO wireless channels: capacity and performance," in *Proceedings Global Telecommunications Conference*, vol. 2, pp. 1083-1088, Nov. 2000,
- [16] R. B. Ertel, P. Cardieri, K. W. Sowerby, T. S. Rappaport, J. H. Reed, "Overview of spatial channel models for antenna array communication systems," *Personal Communications, IEEE*, vol. 5, Issue 1, pp. 10 - 22, Feb. 1998.

- [17] G. J. Foschini, "Layered space-time architecture for wireless communication in a fading environment when using multielement antennas," *Bell Labs Tech. J.*, pp. 41-59, Autumn 1996.
- [18] G. J. Foschini, "Some basic layered space time architectures and their performance," *IEEE J. Select. Areas Commun.-Special Issue on MIMO Systems*, 2003.
- [19] W. H. Foy, "Position-location solutions by Taylor series estimation," *IEEE Trans. on Aerosp. Electron. Syst.*, vol. AES-12, No.3, pp. 187-194, March 1976.
- [20] L. C. Godara, "Applications of antenna arrays to mobile communications and part I: Performance improvement and feasibility and system considerations," *IEEE Proceedings*, vol. 85, No. 7, pp. 1031-1060, July 1997.
- [21] L. C. Godara, "Applications of antenna arrays to mobile communications and part ii: Beamforming and direction-of-arrival considerations," *IEEE Proceedings*, vol. 85, No. 8, pp. 1195-1245, August 1997.
- [22] M. Haardt, "Efficient One-, Two-, and Multi-dimensional High-Resolution Array Signal Processing," Ph.D. Thesis, Shaker Verlag, Aachen, Germany, 1996.
- [23] M. Haardt and J. A. Nossek, "Unitary ESPRIT: how to obtain increased estimation accuracy with a reduced computational burden," *IEEE Tran. Signal processing*, vol.43, pp. 1232-1242, May 1995.
- [24] M. Haardt, M.D. Zoltowski, C.P. Mathews, and J.A. Nossek, "2D Unitary ESPRIT for efficient 2D parameter estimation," in *Proc. IEEE Int. Conf. Acoustics, Speech, Signal Processing*, Detroit, May 1995.
- [25] M. Haardt and J.A. Nossek, "Simultaneous Schur Decomposition of Several Nonsymmetric Matrices to Achieve Automatic Pairing in Multidimensional Har-

- monic Retrieval Problems,” *IEEE Trans. Signal Processing*, 46(1), pp. 161-169, Jan. 1998.
- [26] B. Hassibi, B. Hochwald, “Optimal Training in Space-Time Systems,” in *Proc. Conference Record of the Thirty-Fourth Asilomar Conference on Signals, Systems and Computers*, vol. 1, Nov. 2000.
- [27] Simon Haykin, Adaptive Filter Theory, second edition, *Prentice Hall*, 1991.
- [28] W. C. Jakes, Microwave Mobile Communications, 1994 IEEE Press reissue of the original 1974 ATT Press Corp version.
- [29] T. Katagi, I. Chiba, “Review on recent phased array antenna technologies in Japan,” in *Antennas and Propagation Society International Symposium, 2000. IEEE*, vol. 2, pp. 570-573, July 2000.
- [30] J. P. Kermoal, L. Schumacher, P. E. Mogensen, and K. I. Pedersen, “Experimental investigation of correlation properties of MIMO radio channels for indoor picocell scenarios,” in *Proceedings IEEE Vehicular Technology Conference, IEEE VTC*, vol. 1, pp. 14-21, Fall 2000.
- [31] D. Kim, M. A. Ingram, and W. W. Smith, “Small-scale fading for an indoor wireless channel with modulated backscatter,” in *Proc. 2001 IEEE 54th Veh. Technol. Conf.*, pp. 1616-1620, Atlantic City, NJ, Oct. 2001.
- [32] H. Krim, M. Viberg, “Two decades of array signal processing research: the parametric approach,” *Signal Processing Magazine, IEEE*, vol. 13, Issue 4, pp. 67 - 94, July 1996.
- [33] J. Li, J. Conan, and S. Pierre, “Position Location of Mobile terminal in Wireless MIMO Communication Systems,” *Journal of Communications and Networks*, vol. 9, no. 3, September 2007.



- [34] J. Li, J. Conan, and S. Pierre, "Joint Estimation of Channel Parameters for MIMO Communication Systems," in *2nd International Symposium on Wireless Communication Systems*, vol. 1, pp. 12-16, Sep. 2005.
- [35] J. Li, J. Conan, and S. Pierre, "Mobile Terminal Location for MIMO Communication Systems," *IEEE Transaction on Antenna and Propagation*, vol. 1, no. 3, September 2007.
- [36] J. Li, J. Conan, and S. Pierre, "Using Antenna Array in Multipath Environment for Wireless Sensor Positioning," in *The 64th IEEE Vehicular Technology Conference (VTC2006-Fall)*, Fall 2006.
- [37] Joseph C. Liberti, T.S. Rappaport, *Smart Antenna for Wireless Communications: IS-95 and Third Generation CDMA Applications*, Prentice Hall, 1999.
- [38] Changlin Ma, R. Klukas, and G. Lachapelle, "An Enhanced Two-Step Least Squared Approach for TDOA/AOA Wireless Location," in *IEEE International Conference on Communications (ICC)*, vol. 2, pp. 987-991, May 2003.
- [39] M. McGuire, K. Plataniotis, and A. Venetsanopoulos, "Estimating position of mobile terminals from delay measurements with survey data," in *Canadian Conference on Electrical and Computer Engineering*, vol. 1, pp. 129-134, 2001.
- [40] J. Medbo and J.-E. Berg, "Spatio-temporal channel characteristics at 5GHz in a typical office environment," in *Proc. 2001 IEEE 54th Veh. Technol. Conf.*, vol.3, pp. 1256-1260, Atlantic City, NJ, Oct. 7-11, 2001.
- [41] A. F. Molisch, M. Steinbauer, M. Toeltsch, E. Bonek, and R. S. Thoma, "Capacity of MIMO systems based on measured wireless channels," *IEEE J. Selected Areas Commun.*, vol. 20, pp. 561-569, Apr. 2002.

- [42] Motorola, "Time aligned IPDL positioning technique," *TSGR1 7(99)b79,3GPP*, 1999.
- [43] A. Naguib, N. Seshadri, and R. Calderbank, "Increasing data rate over wireless channels," *IEEE Signal Processing Mag.*, vol. 17, pp. 76-92, May 2000.
- [44] A.J. Paulraj, E. Lindskog, "A Taxonomy of Space-Time Processing for Wireless Networks," in *IEEE Proceedings on Radar, Sonar and Navigation*, vol. 145, no.1, pp. 25-31, Feb. 1998.
- [45] A.J. Paulraj, C.B. Papadias, "Space-Time Processing for Wireless Communications," *IEEE Signal Processing Magazine*, pp. 49-83, Nov. 1997.
- [46] K. I. Pedersen, J. B. Andersen, J. P. Kermoal, and P. Mogensen, "A stochastic multiple-input-multiple-output radio channel model for evaluation of space-time coding algorithms," in *Proc. 2000 IEEE 52nd Veh. Technol. Conf.*, vol. 2, pp. 893-897, Boston, MA, Sept. 2000.
- [47] G. G. Raleigh and J. M. Cioffi, "Spatio-temporal coding for wireless communication," *IEEE Trans. Commun.*, vol. 46, no. 3, pp. 357-366, 1998.
- [48] T.S. Rappaport, *Wireless Communications: Principles and Practice*, Prentice Hall, 1996.
- [49] R. Roy and T. Kailath, "ESPRIT- estimation of signal parameters via rotational invariance techniques," *IEEE Trans. on Acoustics, Speech, and Signal Processing*, vol. 37, pp. 984-995, July 1989.
- [50] A. M. Sayeed, "Modeling and capacity of realistic spatial MIMO channels," in *Proc. 2001 IEEE Intl. Conf. Acoustics, Speech, and Signal Processing*, vol. 4, pp. 2489-2492, Salt Lake City, UT, May, 2001.

- [51] R. O. Schmidt, "Multiple emitter location and signal parameter estimation," *IEEE Trans. Ant. and Prop.*, vol. AP-34, no. 3, pp. 276-280, 1986.
- [52] N. Seshadri and J. H. Winters, "Two schemes for improving the performance of frequency-division duplex (FDD) transmission systems using transmitter antenna diversity," *Int. J. Wireless Information Networks*, vol. 1, pp. 49-60, Jan. 1994.
- [53] D-S. Shiu, G. J. Foschini, M. J. Gans, and J. M. Kahn, "Fading correlation and its effect on the capacity of multielement antenna systems," *IEEE Transactions on Communications*, vol. 48, no. 3, pp. 502-513, March 2000.
- [54] O. Simeone, U. Spagnolini, "Channel estimation for block-fading frequency-selective Rayleigh MIMO channels: performance limits," in *IEEE Vehicular Technology Conference*, Milan, May 2004.
- [55] M. Steinbauer, A. F. Molisch, and E. Bonek, "The double-directional radio channel," *IEEE Antennas and Propag. Mag.*, vol. 43, pp. 51-63, Aug. 2001.
- [56] P. Stoica and A. Nehorai, "MUSIC, maximum likelihood and Cramer-Rao bound," *IEEE Trans. Acoust., Signal Processing*, vol. 37, pp. 720-741, May 1989.
- [57] S. Talwar, M. Viberg, and A. Paulraj, "Blind estimation of multiple co-channel digital signals using an antenna array," *Signal Processing Letters, IEEE*, vol. 1, Issue 2, pp. 29-31, Feb. 1994.
- [58] V. Tarokh, N. Seshadri, and A. R. Calderbank, "Space-time codes for high data rate wireless communication: Performance criterion and code construction," *IEEE Trans. Inform. Theory*, vol. 44, pp. 744-765, Mar. 1998.

- [59] S. Tekinay, E. Chao, and R. Richton, "Performance benchmarking for wireless location systems," *IEEE communication magazine*, vol. 36, No.4, pp.72-76, April 1998.
- [60] N. Thomas, D. Cruickshank, and D. Laurenson, "Performance of a TDOA-AOA hybrid mobile location system systems," in *Second International Conference on 3G Mobile Communication technologies*, pp. 216-220, 2001.
- [61] H. L. Van Trees, Optimum Array Processing, Part IV of Detection, estimation, and Modulation Theory, *Wiley Interscience*, New York, 2002.
- [62] Rose Trepkowski, "Channel Estimation Strategies for Coded MIMO Systems," master thesis of Virginia Polytechnic Institute and State University, 2004.
- [63] A.J. van der Veen, M. C. Vanderveen, A. Paulraj, "Joint angle and delay estimation using shift-invariance techniques," *Signal Processing, IEEE Transactions on*, vol. 46, Issue 2, pp. 405 - 418, Feb. 1998.
- [64] M. C. Vanderveen, C. B. Papadias, and A. Paulraj, "Joint angle and delay estimation (JADE) for multipath signals arriving at an antenna array," *IEEE Communications Letters*, 1(1), 12-14, Jan. 1997.
- [65] S. Venkatraman, J. Caffery Jr. and H.R.You, "Location using LOS range estimation in NLOS environments," in *Proc. IEEE Vehicular Technology Conference*, vol. 2, pp. 856-860, Spring 2002.
- [66] E. Villier, L. Lopes, and B. Ludden, "Performance of a handset-assisted positioning method for GSM," in *Proc. IEEE Vehicular Technology Conference*, vol. 3, pp. 1967-1972, 1999.
- [67] M. Vossiek, L. Wiebking, P. Gulden, J. Wieghardt, C. Hoffmann, "Wireless local positioning - Concepts, solutions, applications," in *Radio and Wireless Conference, 2003. RAWCON '03. Proceedings*, pp. 219-224, Aug. 2003.

- [68] M. Vossiek, L. Wiebking, P. Gulden, J. Wiegardt, C. Hoffmann, P. Heide, "Wireless local positioning," *Microwave Magazine, IEEE*, vol. 4, Issue 4, pp. 77-86, Dec. 2003.
- [69] S. Wang, M.Green, "Mobile positioning method for non-line-of-sight situation," in *Proc. IEEE Vehicular Technology Conference*, vol. 2, pp. 608-612, Sept. 2000.
- [70] S. S. Wang, M. Green, M. Malkawi, "Mobile positioning technologies and location services," in *Radio and Wireless Conference, 2002. RAWCON 2002. IEEE*, pp. 9-12, Aug. 2002.
- [71] A. Wittneben, "A new bandwidth efficient transmit antenna modulation diversity scheme for linear digital modulation," in *Proc. IEEE ICC'93*, vol. 3, pp. 1630-1634, Geneva, Switzerland, 1993.
- [72] Y. Wu, J. Li, and S. Pierre , "Enabling Mobile Commerce Through Location Based Services," in *The 2005 IFIP International Conference on Intelligence in Communication Systems (INTELLCOMM 2005)*, Oct. 2005.
- [73] M. P. Wylie and S. Wang, "Robust range estimation in the presence of the non-line-of-sight error," in *Proc. IEEE Vehicular Technology Conference*, vol. 1, pp. 101-105, Fall 2001.
- [74] K. Yu, M. Bengtsson, B. Ottersten, D. McNamara, P. Karlsson, and M. Beach, "A wideband statistical model for NLOS indoor MIMO channels," in *Proceedings IEEE Vehicular Technology Conference. IEEE VTC*, vol. 1, pp. 370-374, Spring, 2002.
- [75] K. Yu, M. Bengtsson, B. Ottersten, D. McNamara, P. Karlsson, and M. Beach, "A 20 MHz HiperLAN/2 MIMO channel model in NLOS indoor scenarios," in *Proceedings Konferensen Radio Vetenskap och Kommunikation (RVK) '02*, pp. 311-315, 2002.