



Production of purified hemicellulose-pectin fractions of different molecular weight from discarded carrots by hydrothermal treatment followed by multistep ultrafiltration/diafiltration

Marta Ramos-Andrés, Beatriz Aguilera-Torre, Juan García-Serna*

Grupo de Ingeniería de Procesos a Presión, Instituto de Bioeconomía de la Universidad de Valladolid (BioEcoUVA), Departamento de Ingeniería Química y Tecnología del Medio Ambiente, Escuela de Ingenierías Industriales, Universidad de Valladolid, 47011, Valladolid, Spain

ARTICLE INFO

Handling Editor: Zhen Leng

Keywords:

Hydrothermal
Hemicellulose
Pectin
Polydispersity
Membrane
Film

ABSTRACT

Hemicelluloses and pectins are good candidates as biopolymers for the formation of products such as packaging films. Purified freeze-dried fractions of hemicelluloses and pectins, of different molecular weights, were obtained by treating hydrothermal extracts (140, 160, and 180 °C) of discarded carrots with ultrafiltration membranes (30, 10, 5, and 1 kDa). After each ultrafiltration, several cycles of diafiltration with partial water reuse were applied, obtaining a better separation and purification. A cascade configuration (30-10-5-1 kDa) was used in the 140 and 160 °C extracts, and a mixed configuration (5-10-1 kDa) in the 180 °C extract. High molecular weight hemicelluloses increased in concentration by a factor of 5 in the cascade configuration and by a factor of 16.67 in the mixed configuration. A high removal of free sugars (98.9–99.5 wt%) and by-products (94.4–99.2 wt%) through 1 kDa permeate and diafiltration waters was obtained. The system allowed moving from feeds with molecular weight, polydispersity, and purity in the ranges 9.02–18.83 kDa, 16.2–31.6, and 30.12–33.51 wt% to fractions with values in the ranges 2.59–102.75 kDa, 1.2–4.0, and 73.1–100 wt%.

1. Introduction

The global economy is highly dependent on fossil sources for products and energy. Their long-term consumption is environmentally unsustainable due to their depletion and the impact and pollution problems associated with their use. It is important to find other organic sources allowing the development of processes and products in a cleaner, more sustainable and renewable way.

1.1. Food waste is a worldwide issue

One of the main waste products worldwide is vegetable food waste. This waste is characterized by a high moisture content which makes it difficult to manage. Most of it is dumped into the field or landfills, while a small part is used as animal feed. This behavior creates environmental problems due to the putrefaction processes occurring quickly in the area. In particular, carrot production generates around 30 wt% of discards due to several reasons (Marić et al., 2018): damage during the production process, not meeting market standards in terms of shape, size or colour, pulp generated in juice companies and withdrawal in

supermarkets due to some degradation, among others. Although the priority is to minimize the waste, it is of great importance to be able to treat it appropriately to take advantage of the components of interest it contains. Discarded carrots are a source of vitamins, carotenoids, minerals, sugars and dietary fiber.

In previous studies, we have focused on the valorization of discarded carrot pulp and discarded carrot juice. The valorization of the juice focused on sugars and nutrients through fermentation, and carotenoids through encapsulation and drying. The valorization of the pulp was based on hydrothermal treatment for the extraction of free sugars and high molecular weight hemicelluloses and pectins, leaving a residual pulp with abundant cellulose content (Ramos-Andrés et al., 2020). The present work aims at the conditioning of the hydrothermally extracted hemicelluloses and pectins for use in the production of high value-added products.

1.2. Hemicelluloses

Hemicelluloses are the second most abundant biopolymers in plants after cellulose. If hemicelluloses are extracted cost-efficiently in their

* Corresponding author.

E-mail address: juan.garcia.serna@uva.es (J. García-Serna).

<https://doi.org/10.1016/j.jclepro.2021.128923>

Received 3 June 2021; Received in revised form 24 August 2021; Accepted 2 September 2021

Available online 9 September 2021

0959-6526/© 2021 The Authors.

Published by Elsevier Ltd.

This is an open access article under the CC BY-NC-ND license

(<http://creativecommons.org/licenses/by-nc-nd/4.0/>).

polymeric form they can be used in the formation of hydrogels, biodegradable barrier films for food packaging, paper additives, adhesives, thickeners, emulsifiers, stabilizers, and binders in the food, pharmaceutical, and cosmetic industries (Thuvander and Jönsson, 2020). The most common methods used for hemicelluloses extraction are alkaline, organosolv, acid, and hydrothermal treatments, among others. Hydrothermal treatment has important advantages as it uses only biomass and water as reagents, with no need for subsequent neutralization or desalting, and reduces corrosion in the equipment used. The species responsible for the autohydrolysis phenomenon in the hydrothermal treatment are the hydronium ions formed in the water at temperatures above 120 °C and the organic acids released during extraction.

Hemicelluloses extracted by almost any method, and especially by hydrothermal treatment, are accompanied by a number of co-extracted compounds such as monosaccharides, organic acids, extractives, degradation compounds and certain lignin derivatives. Hemicelluloses require purification to be used in any application. The main purification methods are ultrafiltration (UF), ethanol precipitation, and chromatography. Although the latter two methods seem to give more homogeneous fractions, UF is the most widely used in recent research due to its significant operational advantages (Arkell et al., 2013a). Membrane operation is characterized by low chemical consumption (for cleaning only), low energy requirement (with operating conditions close to ambient), scalability and flexibility of operation, providing a cleaner and more efficient purification process. The main challenge of this purification method is membrane fouling, which is reduced by feed pre-treatments such as microfiltration or some heating to reduce viscosity. Diafiltration (DF) is an important post-treatment to mitigate fouling. The reduction of the feed volume during UF allows concentration and partial purification, but DF ensures complete purification by removing unwanted substances. DF consists of diluting the retentate by adding water and applying UF, repeating this cycle until the desired level of impurities removal is reached. This method is probably the most cost-effective for hemicelluloses purification (Al Manasrah et al., 2012).

1.3. Pectins

Pectins are heteropolysaccharides present in the primary cell wall and middle lamella of higher plants. They consist mostly of α -galacturonic acid subunits with a variable content of methyl esters occurring in the acid group. This region of the pectins is called homogalacturonan. Other monosaccharides such as arabinose, galactose, and rhamnose may also be present in smaller proportions (Babbar et al., 2016). The industrial extraction of pectin is performed from fruit peel (waste from the juice industry), mainly from citrus fruits (Grassino et al., 2018). Other residues also contain pectins and although sometimes not in high quantities, they may be of better quality (Grassino et al., 2016). Some of these raw materials are olive pomace, berry pomace, potato pulp, and carrot pulp. Once extracted, pectins are used in the food industry as additives for thickening, gelling, stabilizing, and emulsifying agent in jams, jellies, soft drink, fish, meat, fruit juice, and milk product, as well as a fat replacer in spreads, salad dressing, ice cream, and emulsified meat products (Raji et al., 2017). For food applications, pectins are required to contain at least 65% galacturonic acid subunits (Schmidt et al., 2017). Another application starting to be studied is pectin in its oligosaccharide form, with a lower molecular weight, which can be used as a prebiotic agent (Babbar et al., 2016).

The most common extraction method for pectins is acidic extraction using a dilute mineral acid (hydrochloric acid, nitric acid, and sulfuric acid). These acids have the advantage of low price and high extraction yield, but their major disadvantage is toxicity and harmful effects on the environment (Jafari et al., 2017). Other more environmentally friendly extraction methods are enzyme-assisted extraction, ultrasound-assisted extraction, microwave-assisted extraction, subcritical water extraction, and induced electric field-assisted extraction (Dranca and Oroian, 2018). After extraction, pectins have to be purified for application by

reducing the presence of co-extracted sugars and acids. The main method is precipitation using an organic solvent, usually ethanol, either in a single step or in several steps. Other methods also used are dialysis, ionic exchange, nitration, as well as combined methods (Dranca and Oroian, 2018). Novel, more environmentally friendly methods include UF in combination with DF, UF, metal precipitation, copper precipitation, and purification using protein (sodium caseinate) (Dranca and Oroian, 2018).

1.4. Films from hydrothermally extracted biopolymers

The hydrothermal extraction of hemicelluloses and pectins from discarded carrots by means of a flow-through configuration allows obtaining these biopolymers with high molecular weight, together with other components (Ramos-Andrés et al., 2020). A concentration, separation, and purification treatment as in the present work allows obtaining fractions suitable for film manufacture. Edible films are a good alternative for the conservation of food because they have good properties among which are their biodegradability and zero toxicity. They also stand out because they can act naturally as antimicrobials or antioxidants (Rojas et al., 2015). These films are characterized as being a very good barrier to gases, although not so good to water vapor, as their raw material (polysaccharides and/or proteins) is hydrophilic (Rojas et al., 2015).

1.5. Purification using membranes applying ultrafiltration and diafiltration

Membranes have been used as a purification method with almost all types of hemicellulose extraction methods, such as hemicelluloses extracted by alkaline treatment and recovered using UF (Laine et al., 2015) and nanofiltration (Arkell et al., 2013b). Persson et al. (2010) fractionated process water from a thermomechanical pulp mill into five fractions using filtration, ultrafiltration, and nanofiltration. Rico et al. (2018) valorized peanut shells by hydrothermal extraction of hemicelluloses and lignin-derivative compounds. Successive DF stages allowed obtaining a purity of 72.4 wt%. Krawczyk et al. (2008) extracted hemicelluloses by steam explosion from barley husks. They applied prefiltration followed by an UF/DF system, which increased the purity of the hemicelluloses from 40 to 70 wt%.

Several authors have used several membranes, either in series or in parallel, as in the present work. González-Muñoz et al. (2013) extracted hemicelluloses from *Pinus pinaster* wood with a purity of 69.6 wt%. Concentration, purification, and fractionation were carried out by successive stages of DF and concentration with MWCO 10, 5, 3, 1, and 0.3 kDa membranes. The purification effects were mainly seen in the 5 and 3 kDa membranes, enabling the generation of manooligosaccharides with tailored molecular weight distributions. In the case of Sukhbaatar et al. (2014), after extraction of sugarcane bagasse hemicelluloses by hydrothermal treatment, UF and nanofiltration were performed in series with MWCO 10, 1, and 0.4 kDa membranes to recover high molecular weight hemicelluloses and oligomers. Al Manasrah et al. (2012) applied hydrothermal treatment to spruce-sawdust and recovered galactoglucomannan which was further processed with three membranes of 5, 10, and 30 kDa. The best results were obtained with the 5 kDa membrane, with 88% retention, 63 wt% purity, and 70% recovery, using a feed volume reduction of 86 vol%. DF did not improve the purity of galactoglucomannan due to overlapping of the lignin molecular weight distribution. This problem was not present in this work due to the negligible lignin content in the extracts.

In one of our previous works, hydrothermal treatment was applied to spent coffee grounds followed by cascade UF/DF with three membranes of MWCO 30, 10, and 5 kDa for separation and purification of the hemicelluloses (Ramos-Andrés et al., 2019). Thanks to DF, the retention of co-extracted by-products was reduced from 45.6 to 8.7 wt%, obtaining fractions with average molecular weights from 1.6 to 49.7 kDa

and purities between 83.7 and 97.8 wt%. Although these purity values were high, this was also because the purity of the feed was relatively high (75.2–84.3 wt%). In the present work, a higher number of DF cycles were applied as the purity values of the feeds were lower (approx. 30%) mainly due to free sugars. Compared to our previous work, in the present work an additional 1 kDa membrane was used to recover the abundant hemicelluloses between 1 and 5 kDa. Also, all the membranes used were bigger, which meant great advantages in the operation and allowed to obtain fractions of sufficient volume to proceed to drying and characterization of the solid. As in our previous work, the purity was high (73.1–100%) compared to the obtained in other studies (63.0–72.4%). Not only the high purity is remarkable, but also the molecular weight achieved in the present work was very high in relation to the usual due to both the flow-through extraction previously performed (Ramos-Andrés et al., 2020) and the efficient operation with the membranes.

1.6. Aim of this work

To our knowledge, there are no studies using membranes for the recovery of components from discarded carrots, namely hemicelluloses, and pectins. Our previous work on hydrothermal treatment of discarded carrots at different temperatures yielded extracts with a very wide molecular weight distribution due to the presence of different hemicelluloses/pectins and especially the presence of free sugars (Ramos-Andrés et al., 2020). The present work is focused on the processing of these novel extracts characterized by excellent quality hemicelluloses/pectin of both very high and moderate molecular weight. The hydrothermal extracts of purity close to 30 wt% were processed with four cascade membranes applying UF, multiple DF cycles, and drying, which allowed obtaining defined and high-purity solid fractions of biopolymers containing hemicellulose and pectin. These fractions have different potential applications depending on their molecular weight.

2. Materials and methods

2.1. Raw material and sample preparation

Discarded carrots were supplied by the company Muñozval S.L. (Valladolid, Spain). They were washed with tap water and stored in a cool, dry, and dark place for the shortest time. Discarded carrots were processed with a juice extractor (Moulinex ZU5008 Infinity Press Revolution) yielding approximately 0.545 kg of pulp per 1 kg of discards.

While the juice was valorized following a different strategy, the pulp was subjected to hydrothermal treatment in a flow-through reactor for the extraction of free sugars, hemicelluloses, and pectins, as explained in our previous article (Ramos-Andrés et al., 2020). The biomass is loaded into the reactor with the help of a cartridge. The water is bypass through the plant until it reaches the desired temperature, after which it circulates through the heated reactor from top to bottom, performing the extraction. The reactor outlet stream exchanges heat with the inlet stream to save energy. Three experiments were performed extracting at 140, 160, and 180 °C for 80 min. The plant was kept pressurized to ensure the water was always in a liquid state, operating at 6 bar (140 °C), 10 bar (160 °C), and 15 bar (180 °C). The three hydrolysates obtained in the first 25 min of the three extractions were recovered to be subjected to a downstream process. The post-treatment was done immediately to prevent degradation, keeping the liquid at 4 °C whenever a stop in the process was necessary, for example in the cleaning of the membrane. The three hydrothermal extracts were characterized by determining their composition according to the method described in Section 2.4.1. and by determining their molecular weight distribution according to the method in Section 2.4.2.

2.2. UF and DF

The hydrothermal extracts were subjected to several stages of UF and DF with membranes for the concentration, separation, and purification of hemicelluloses and pectins. Concentration was achieved through UF, separation through both UF and DF, and purification mainly through DF. Four UF membranes were used, three of them Pellicon 2 Mini Biomax polymeric membranes, flat sheet configuration, made of polyethersulfone, with molecular weight cut-off (MWCO) of 30, 10, and 5 kDa, and filtration area of 0.1 m². The last membrane of 1 kDa was a Prep Scale-TFF polymeric membrane, spiral wound configuration, made of regenerated cellulose, and filtration area of 0.23 m². To achieve the concentration effect, the feed volume was reduced by 80% (v/v) on each membrane during UF. To improve separation and to carry out purification, the retentates of each membrane were subjected to several DF cycles. In each cycle, a volume of water equal to the volume of the retentate was added and ultrafiltered being recovered as permeate. Each retentate was subjected to 5 DF cycles with distilled water, and up to 3

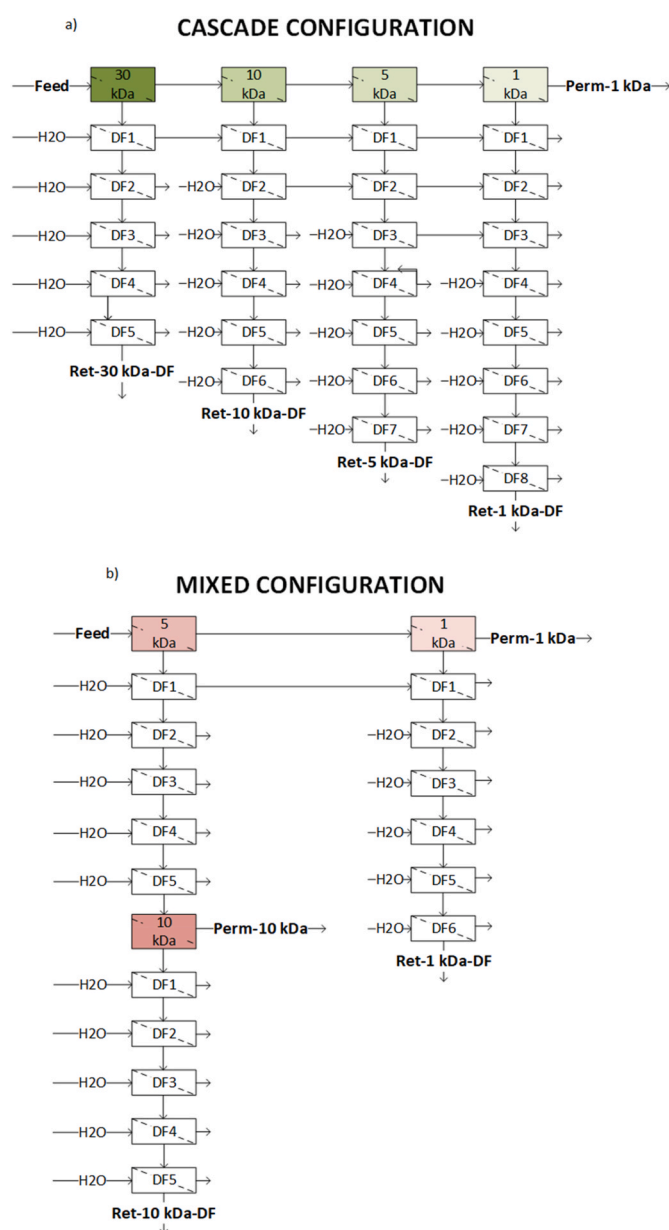

Fig. 1. A) Cascade and B) mixed configuration of the membranes including UF and DF cycles.

DF cycles with water reused from previous DFs according to Fig. 1. The transmembrane pressure was kept in the range 1.5–2.5 bar by a manually adjusted valve on the retentate side, and feed flow was approximately 4.8 L/m²/min.

The first step was to subject each hydrothermal extract to dead-end microfiltration to remove particles larger than 50 µm. After microfiltration, two membrane configurations were used:

- 1) Cascade configuration. It was applied to 140 and 160 °C hydrothermal extracts. The configuration was based on a cascade arrangement of the membranes following a decreasing order of MWCO: 30, 10, 5, and 1 kDa. The four retentates in the cascade underwent several cycles of DF as can be seen in Fig. 1a. The first retentate (Ret-30 kDa) underwent five cycles of DF, the second (Ret-10 kDa) underwent six cycles, the third (Ret-5 kDa) underwent seven cycles, and the fourth retentate (Ret-1 kDa) underwent eight cycles. With Ret-30 kDa only distilled water was used for all five DF cycles. The remaining retentates were also subjected to five DF cycles with distilled water, but prior to these, the retentates were subjected to an additional cycle for each membrane located in the previous position in the cascade. These additional cycles were performed by reusing water from previous DF cycles to recover part of the entrained components.
- 2) Mixed configuration. The 180 °C extract was subjected to this configuration, using only three membranes, as GPC analysis indicates the absence of the highest molecular weight fraction. The first membrane was the 5 kDa MWCO, followed by the 10 kDa and 1 kDa membranes operating in parallel, each with one of the 5 kDa membrane outlets. DF cycles were carried out on the three retentates according to Fig. 1b. Ret-5 kDa underwent five DF cycles with distilled water, Ret-10 kDa also underwent five cycles with distilled water, and Ret-1 kDa, having a higher MWCO membrane before it, it underwent six DF cycles: the first cycle with reused water from the DF of Ret-5 kDa and the last five cycles with distilled water.

The feed streams and all the products obtained in each membrane of MWCO 'X' were sampled: Ret-X kDa, Ret-X kDa-DF and Perm-X kDa. These liquid samples were analyzed for composition following the method described in Section 2.4.1. and for molecular weight distribution following the method described in Section 2.4.2. After each use, the membranes were subjected to a cleaning and flushing stage as recommended by the manufacturer.

2.3. Freeze-drying of the purified fractions

Freeze-drying was used as drying method for the purified fractions of hemicelluloses and pectins obtained after UF/DF. With the cascade configuration using four membranes, four fractions were obtained: Ret-30 kDa-DF, Ret-10 kDa-DF, Ret-5 kDa-DF, and Ret-1 kDa-DF. With the mixed configuration using three membranes, three purified fractions were obtained: Ret-10 kDa-DF, Perm-10 kDa, and Ret-1 kDa-DF. These liquid products were frozen overnight at –25 °C and then freeze-dried under vacuum (0.180 mbar) for 96 h using a Telstar Lyoquest –55 unit (Terrassa, Spain).

2.4. Analysis

2.4.1. Chemical characterization

Composition analysis of the liquid samples was carried out by High-Performance Liquid Chromatography (HPLC) as previously described by Ramos-Andrés et al. (2019). A column SUGAR SH-1011 Shodex was used for the analysis of sugars, uronic acids, aldehydes, organic acids, and degradation compounds. The temperature in the column was maintained at 50 °C and the mobile phase had a flow of 0.8 mL/min of 0.01 N sulfuric acid in Milli-Q water. Sugars, uronic acids, aldehydes, and organic acids were identified and quantified with a Waters IR

detector 2414. Degradation compounds (5-HMF and furfural) were analyzed with a Waters dual λ absorbance detector 2487 (210 nm and 254 nm). To determine the concentration of hemicelluloses and pectins, liquid samples were submitted to standardized hydrolysis to break the hemicelluloses and pectins into monomers. Briefly, 15 mL of Milli-Q water and 0.8 mL of sulfuric acid (72 wt%) were mixed with 5 mL of the sample. The solution was autoclaved at 121 °C for 1 h, and then neutralized with CaCO₃ and filtered (Pore size 0.22 µm, Nylon; FILTER-LAB) before HPLC analysis. The standards used for the analysis were: sucrose (99%), galacturonic acid (97%), glucose (99%), galactose (99%), fructose (99%), arabinose (99%), glycolaldehyde (99%), formic acid (98%), acetic acid (98%), levulinic acid (98%), acrylic acid (99%), 5-hydroxymethylfurfural (99%), and furfural (99%), all of them from Sigma-Aldrich. The concentration of arabinogalactan was calculated using anhydrous corrections of 0.9 (galactose) and 0.88 (arabinose). Galacturonic acid from pectins was corrected by 0.9 as an anhydrous factor.

2.4.2. Molecular size distribution

Molecular size distribution was determined by Size Exclusion Chromatography (HPLC-SEC) using the method previously described by Ramos-Andrés et al. (2019). A GPC column (SB-803 HQ; Shodex) was used together with a guard column (SB-G; Shodex). The temperature in the column was maintained at 35 °C. The mobile phase had a flow rate of 0.5 mL/min (NaNO₃ 0.1 M + NaN₃ 0.02% in Milli-Q water). A Waters IR detector 2414 was used to determine the molecular weight distribution of the liquid samples. The calibration curve was determined with a set of 5 pullulan standards (STANDARD P-82; Shodex) dissolved in Milli-Q water, ranged between 6.1 and 113 kDa of weight-average molecular weight. The chromatographic curves were integrated and the area under the curve was divided into regions for classifying in different groups depending on the molecular weight: (1) monomers, (2) dimers, (3) pentamers, (4) hexamers, (5) 1–5 kDa, (6) 5–10 kDa, (7) 10–30 kDa, and (8) >30 kDa. The groups of trimers and tetramers were under the limit of detection.

2.4.3. Structural characterization (FTIR, TGA)

The purified solid fractions of hemicelluloses and pectins were structurally characterized by Attenuated total reflectance (ATR) – Fourier transform infrared spectroscopy (FT-IR) (Bruker, Alpha model, with a Platinum ATR single reflection diamond module). The absorbance spectra were obtained in a wavenumber range from 4,000 to 400 cm⁻¹, acquiring 64 scans per sample at a resolution of 4 cm⁻¹.

The structure of each purified fraction was also studied through thermogravimetric analysis (TGA) carried out in a TGA/SDTA RSI analyzer of Mettler Toledo. Samples of approximately 10 mg were heated at 10 °C/min under nitrogen atmosphere (60 NmL/min) from a temperature of 50 °C up to around 900 °C.

3. Results and discussion

The main data of the paper used in the tables and figures can be accessed [here](#).

3.1. Hydrothermal extracts characterization

It was analyzed the composition of the three hydrothermal extracts recovered in the first 25 min of the flow-through extraction, obtained at 140 °C (Feed-140), 160 °C (Feed-160), and 180 °C (Feed-180). These extracts were the feeds of the UF/DF system and their composition is listed in Table 1.

As in the present work, a previous work has shown extracted hemicelluloses from carrot pulp were of the arabinogalactan type, with a majority proportion of galactose versus arabinose (Ribas-Agustí et al., 2014). As shown in Table 1, the concentration of arabinogalactan was 592.7 mg/L (140 °C), 935.3 mg/L (160 °C), and 1,556.2 mg/L (180 °C)

Table 1

Chemical composition of the hydrothermal extracts extracted at 140 °C (Feed-140), 160 °C (Feed-160), and 180 °C (Feed-180) feeding the membrane configurations.

	Feed-140	Feed-160	Feed-180
Biopolymers (mg/L)	882.3	1,427.5	2,173.7
Galacto- (mg/L)	356.1	660.4	1,223.1
Arabino- (mg/L)	236.6	274.9	333.1
Arabinogalactan (mg/L)	592.7	935.3	1,556.2
Pectin (mg/L)	289.6	492.2	617.5
Free sugars (mg/L)	1,765.4	2,340.8	3,093.9
Sucrose (mg/L)	820.1	1,012.9	1,166.6
Glucose (mg/L)	483.4	704.6	1,130.6
Fructose (mg/L)	461.9	623.3	796.7
By-products (mg/L)	175.5	491.72	952.8
Arabinose (mg/L)	21.88	n.d.	174.7
Glycolaldehyde (mg/L)	32.21	82.72	140.7
Formic Acid (mg/L)	30.74	216.1	278.6
Acetic Acid (mg/L)	41.58	45.40	88.32
Levulinic Acid (mg/L)	1.93	15.76	3.89
Acrylic Acid (mg/L)	45.31	120.6	218.1
5-HMF (mg/L)	1.80	11.09	45.54
Furfural (mg/L)	n.d.	n.d.	3.04

in the hydrothermal extracts obtained. Pectin biopolymer of the homogalacturonan type was present with a concentration of 289.56, 492.2, and 617.5 mg/L. Despite the biopolymers degradation caused by a higher extraction temperature, the extraction kinetics was accelerated along with temperature resulting in a higher concentration of both biopolymers in the collected extracts corresponding to the first 25 min of extraction time. The free sugars were the majority components of the extracts. These are the sugars also present in the juice, the most abundant being sucrose followed by glucose and fructose. Again, despite the degradation, a higher concentration of free sugars was obtained at a higher temperature during the first 25 min of extraction: 1,765.41 mg/L (140 °C), 2,340.79 mg/L (160 °C), and 3,093.90 mg/L (180 °C). By-products accompanying hemicelluloses, pectins, and free sugars can be classified into those of the first degree coming from the transformation of one of the products (glycolaldehyde, 5-HMF, furfural, arabinose, and acetic acid) and those of the second degree coming from the transformation of other by-products (levulinic acid, formic acid, and acrylic acid) (Ramos-Andrés et al., 2020). The total concentration of by-products was 175.45 mg/L (Feed-140), 491.72 mg/L (Feed-160), and 952.82 mg/L (Feed-180).

Fig. 2 shows the molecular weight distribution of the three hydrothermal extracts. In this distribution, the main molecular groups can be identified. The first peak on the left in the chromatograms is associated

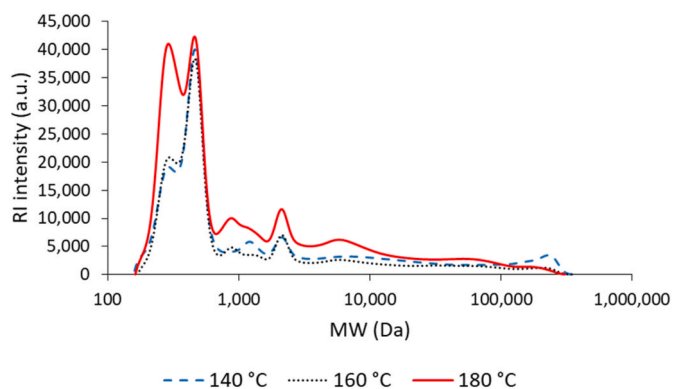

Fig. 2. Molecular weight distribution of the hydrothermal extracts extracted at 140 °C (Feed-140), 160 °C (Feed-160), and 180 °C (Feed-180) feeding the membrane configurations.

with the monomers (glucose, fructose, and arabinose) and the second with the dimers (sucrose). Other important groups were close to 1 kDa, between 1 and 5 kDa, between 5 and 10 kDa, and >30 kDa. The use of UF membranes with MWCO of 1, 5, 10, and 30 kDa allows separating these groups and obtaining more defined fractions with less polydispersity. The polydispersity of the hydrothermal extracts was too high to allow specific application as biopolymers. The main cause of this high value was the presence of free sugars together with the extraction of hemicelluloses and pectins of the highest molecular weight. The weight-average molecular weight (MW) and PD parameters of the molecular weight distributions shown in Fig. 2 were: 18,833 Da and 31.55 (Feed-140), 10,977 Da, and 19.94 (Feed-160), 9,017 Da, and 16.16 (Feed-180).

As it can be seen in Table 1 and Fig. 2, Feed-180 had a higher presence of monomers than Feed-140 and Feed-160, which is associated with a greater extraction, greater hydrolysis of sucrose into its monomers, and a greater autohydrolysis of arabinogalactan releasing arabinose units. As for the molecular weight groups higher than sucrose but < 30 kDa, Feed-180 was the most concentrated feed, being Feed-140 and Feed-160 similar to each other. This higher concentration can be associated with both a higher extraction and the phenomenon of autohydrolysis at a higher temperature. With respect to the molecular group > 30 kDa, the concentration was lower the higher the extraction temperature. This can be associated with the phenomenon of autohydrolysis during extraction. The autohydrolysis effect occurs at temperatures higher than 120 °C when the water is ionized forming H_3O^+ ions which cause partial depolymerization of hemicelluloses and pectins. The acetyl and methyl groups of hemicelluloses and pectins are cleaved leading to the subsequent formation of H_3O^+ ions that autocatalyze the depolymerization process (Ramos-Andrés et al., 2020).

3.2. Concentration applying UF and DF

The feed volume reduction in the UF process allowed to increase the concentration of each molecular group. Those groups whose molecular weight is higher than the MWCO of the membrane are expected to be concentrated since they are retained. Fig. 3 shows on the y-axis the so-called concentration factor, which represents the increase in concentration compared to the concentration in the feed stream of the membrane system (Feed-140, Feed-160, and Feed-180). The concentration factor of each molecular group was calculated as the ratio between the areas under the curve of the HP-SEC chromatogram corresponding to each molecular group, comparing the different streams of the UF/DF system with the feed stream.

The extracts obtained at 140 and 160 °C were subjected to the cascade membrane configuration, while the 180 °C extract was processed with a mixed configuration (Fig. 1). We used these two configurations for optimization purposes, as the higher temperature did not provide very long biopolymers and the use of 30 kDa was dispensable. The different configurations resulted in differences in the concentration factor. The feed volume reduction was in all cases 80 v/v% so the maximum theoretical increase in concentration for those groups totally retained was 5-fold.

As can be seen in Fig. 3A and B, the group > 30 kDa reached a concentration factor of 5 in Ret-30 kDa. After DF, this factor was maintained in Ret-30 kDa-DF, so hemicelluloses and pectins > 30 kDa were effectively retained. With regard to the molecular groups < 30 kDa, they were partially retained in Ret-30 kDa, in greater proportion as their molecular weight increased. The concentration factors of these groups were found to be between 0.92 and 5.00 for Feed-140 and between 0.05 and 4.91 for Feed-160. After applying the five cycles of DF and obtaining Ret-30 kDa-DF, the retention of the groups < 30 kDa decreased considerably. The concentration factor was 0 for molecular weight groups < 1 kDa, and for groups > 1 kDa it was between 0.20 and 4.55 (Feed-140) and between 0.70 and 3.77 (Feed-160).

With regards to the retentates of the other membranes in the cascade

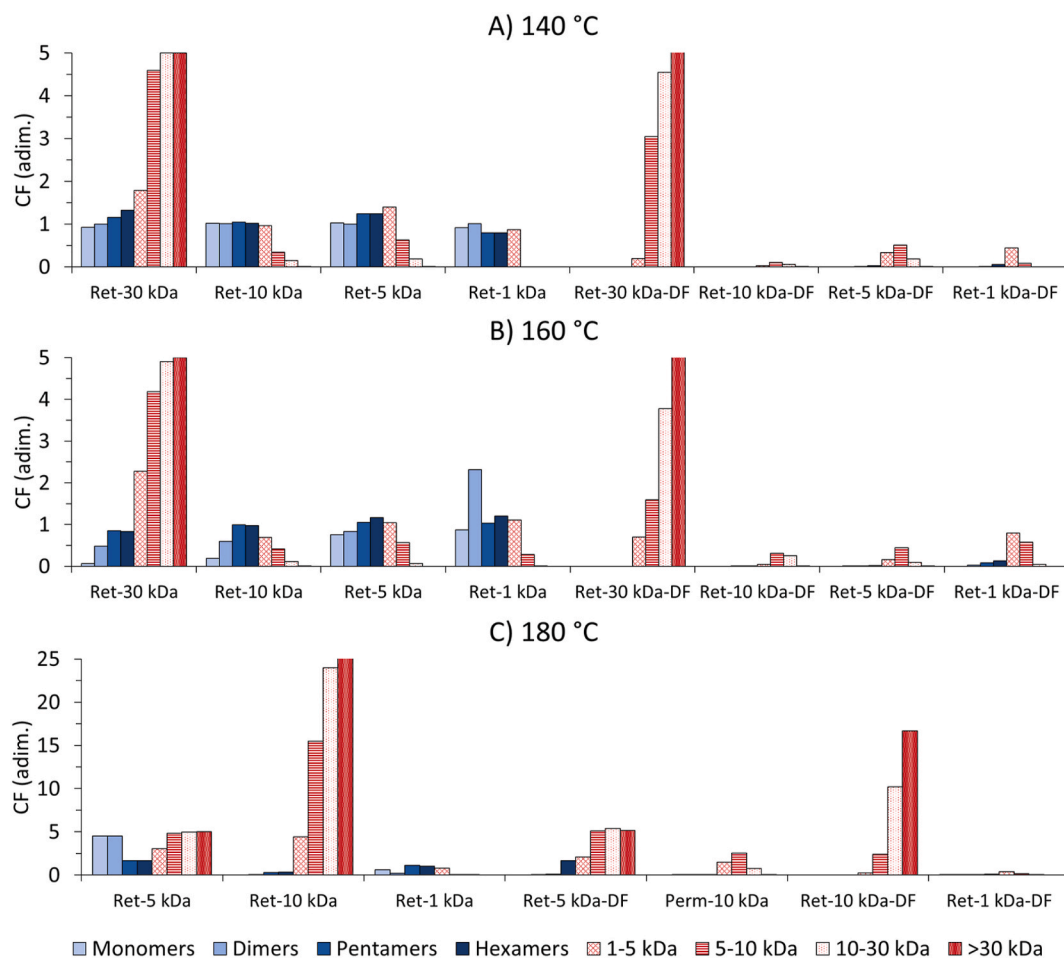

Fig. 3. Concentration factor (CF) of the different groups of hemicelluloses-pectins in each of the UF and UF/DF products compared to the feed stream.

(Ret-10 kDa, Ret-5 kDa, and Ret-1 kDa) their concentration with respect to the feed did not increase as significantly since the great part of the extract was retained in the first membrane (Ret-30 kDa). The molecular groups in the three retentates showed a concentration factor around 1 when operated with Feed-140. When Feed-160 was processed, the concentration factor in Ret-10 kDa was less than 1, being concentrated mainly the pentamers and hexamers, probably the most abundant groups in the feed of the 10 kDa membrane. It is worth noting an increase of 2.32-fold in the concentration of Ret-1 kDa dimer group of Feed-160, which may be due to a not very effective mass transfer through the membrane in this case. After applying the multiple DF cycles, the overall concentration of Ret-10 kDa-DF, Ret-5 kDa-DF, and Ret-1 kDa-DF was much lower than the feed concentration, but a more sharpen molecular weight distribution can be seen (Fig. 3A and B). Those molecular groups not interested in retaining (<1 kDa) experienced a maximum concentration factor of 0.05 for Feed-140 and 0.13 for Feed-160, both in Ret-1 kDa-DF, so the concentration of non-target groups was reduced considerably by DF. As for the target groups, on Ret-10 kDa-DF the group increasing its concentration the most was 5–10 kDa (as 10–30 kDa was very low in feed), on Ret-5 kDa-DF it was the corresponding group 5–10 kDa and on Ret-1 kDa-DF it was indeed the group 1–5 kDa.

Feed-180 was subjected to the mixed membrane configuration, resulting in 3 products instead of 4 products: Ret-10 kDa-DF, Perm-10 kDa, and Ret-1 kDa-DF. With the first of the membranes (MWCO 5 kDa) the concentration of all the molecular groups increased considerably in Ret-5 kDa, especially those with a molecular weight > 5 kDa, which experienced a concentration factor between 4.84 and 5 (Fig. 3C). Monomers and dimers experienced almost total retention in Ret-5 kDa,

with concentration factors of 4.53 and 4.50. This can be associated with poor mass transfer due to the presence of high molecular weight groups in a membrane with a moderate value of MWCO. After applying the five DF cycles, the presence of monomers and dimers was totally reduced in Ret-5 kDa-DF, keeping the concentration of the rest of the groups the same. This DF process was effective for the purification of the biopolymers, but not for the separation of molecular groups. Ret-5 kDa-DF was passed through the 10 kDa membrane and gave rise to Ret-10 kDa in which groups with a molecular weight > 5 kDa were concentrated with concentration factors between 15.47 and 25, being 25 the maximum possible given the feed volume reductions. After applying DF to Ret-10 kDa, a product with improved characteristics was obtained (Ret-10 kDa-DF). The interest groups, those > 10 kDa, increased their concentration between 10.20 and 16.67. The non-interest groups present were exclusively the group 5–10 kDa with concentration factor 2.42 and the group 1–5 kDa with concentration factor 0.26. The second product was Perm-10 kDa, which had a very low impurities content due to the DF applied on the 5 kDa membrane. The most concentrated group was 5–10 kDa, as it was the most abundant group in the feed. The third product, Ret-1 kDa-DF, was much diluted compared to the feed. It presented good characteristics for not having impurities associated with monomers and dimers, not having molecular groups of very high molecular weight, and having its group of interest (1–5 kDa) the highest concentration factor of the groups present.

3.3. Purification applying UF and DF

Table 2 analyses the separation of each of the four groups of extracted components: arabinogalactan, pectins, free sugars, and by-

Table 2

Recovery of arabinogalactan (AG), pectins, free sugars, and by-products after UF and UF/DF.

	140 °C									
	UF products					UF/DF products				
	Ret-30 kDa	Ret-10 kDa	Ret-5 kDa	Ret-1 kDa	Perm-1 kDa	Ret-30 kDa-DF	Ret-10 kDa-DF	Ret-5 kDa-DF	Ret-1 kDa-DF	DF water
AG	59.31%	5.74%	9.95%	4.46%	20.54%	52.91%	n.d.	1.89%	1.26%	23.40%
Pectins	94.77%	1.65%	3.58%	n.d.	n.d.	74.92%	9.15%	10.45%	5.48%	n.d.
Free sugars	6.56%	15.53%	14.55%	14.38%	48.98%	n.d.	n.d.	n.d.	0.53%	50.49%
By-products	33.16%	23.00%	21.43%	2.14%	20.27%	3.71%	n.d.	n.d.	n.d.	76.02%
	160 °C									
	UF products					DF products				
	Ret-30 kDa	Ret-10 kDa	Ret-5 kDa	Ret-1 kDa	Perm-1 kDa	Ret-30 kDa-DF	Ret-10 kDa-DF	Ret-5 kDa-DF	Ret-1 kDa-DF	DF water
AG	68.43%	5.90%	5.60%	5.77%	14.30%	59.20%	1.40%	1.59%	3.65%	19.86%
Pectins	71.08%	12.98%	7.03%	7.60%	1.31%	71.07%	9.54%	6.77%	6.58%	4.73%
Free sugars	7.82%	18.44%	16.19%	14.89%	42.66%	0.59%	n.d.	0.16%	0.32%	56.27%
By-products	19.80%	14.46%	12.64%	10.84%	42.26%	n.d.	n.d.	0.75%	0.01%	56.98%
	180 °C									
	UF products					DF products				
	Ret-10 kDa	Perm-10 kDa	Ret-1 kDa	DF 5 kDa	Perm-1 kDa	Ret-10 kDa-DF	Perm-10 kDa	Ret-1 kDa-DF	DF water	
AG	55.30%	20.21%	9.22%	n.d.	15.27%	37.46%	20.21%	2.47%	24.59%	
Pectins	55.61%	34.43%	n.d.	9.96%	n.d.	24.97%	38.24%	6.46%	30.33%	
Free sugars	0.82%	0.62%	18.21%	23.82%	56.53%	n.d.	0.81%	0.08%	42.58%	
By-products	1.47%	4.94%	18.17%	9.18%	66.24%	0.18%	5.44%	0.03%	28.11%	

products (percentage is wt%). Each of the groups was distributed in the UF streams or products and in the UF/DF products. In the cascade configuration (Feed-140 and Feed-160) the UF products were Ret-30 kDa, Ret-10 kDa, Ret-5 kDa, Ret-1 kDa, and Perm-1 kDa, whose retentions together added 100 wt%. In the mixed configuration (Feed-180), the UF products were Ret-10 kDa, Perm-10 kDa, Ret-1 kDa, and Perm-1 kDa, which together with DF water from 5 kDa membrane added 100 wt% of retention. After purifying through DF cycles, the products in the cascade configuration were Ret-30 kDa-DF, Ret-10 kDa-DF, Ret-5 kDa-DF, Ret-1 kDa-DF, and Perm-1 kDa, which together with the DF waters added up to 100 wt%. In the mixed configuration, the products of the DF were Ret-10 kDa-DF, Perm-10 kDa, Perm-1 kDa, and the total DF waters (5, 10, and 1 kDa), adding up to 100 wt% retention.

3.3.1. Arabinogalactan (AG)

Regarding the arabinogalactan present in Feed-140, Table 2 shows how it was distributed mainly in Ret-30 kDa (59.31 wt%) and Perm-1 kDa (20.54 wt%), the products of higher and lower molecular weight. Part was retained in the intermediate retentates (Ret-10 kDa, Ret-5 kDa, and Ret-1 kDa), with values in the range 4.46–9.95 wt%. After applying DF, Ret-30 kDa-DF slightly reduced its retention (52.91 wt%). Nothing or a very small percentage of arabinogalactan was recovered in the diafiltered intermediate retentates, having Ret-10 kDa-DF, Ret-5 kDa-DF, and Ret-1 kDa-DF retentions lower than 1.89 wt%. The reduction in the retention of arabinogalactan taking place after DF could be partly compensated by a recovery of arabinogalactan thanks to the reuse of the DF water. Despite this, 23.40 wt% of the total arabinogalactan was lost through DF. A percentage close to 44 wt% was lost due to low molecular weight through Perm-1 kDa and the DF water, while 52.91 wt% was recovered as purified high molecular weight arabinogalactan in Ret-30 kDa-DF.

In the case of Feed-160, most of the arabinogalactan was retained in the first membrane of the cascade (68.43 wt%), with the next largest

part being removed through Perm-1 kDa (14.30 wt%). The remaining arabinogalactan was homogeneously retained in the intermediate retentates (Ret-10 kDa, Ret-5 kDa, and Ret-1 kDa) with values in the range 5.60–5.90 wt%. After applying the DF cycles the retention of arabinogalactan decreased in all membranes, as in the case of Feed-140. Although some of the removed arabinogalactan could be recovered by reusing the DF water, most of it was lost. The retentions decreased to 59.20 wt% (Ret-30 kDa-DF) and to the 1.40–3.65 wt% range (Ret-10 kDa-DF, Ret-5 kDa-DF and Ret-1 kDa-DF). A total of 34.16 wt% was eliminated through Perm-1 kDa and the DF waters, similar to the treatment of Feed-140.

The mixed operation with Feed-180 resulted in a loss of arabinogalactan through Perm-1 kDa of 15.27 wt% while the loss in the Ret-5 kDa DF was nil, as only by-products were removed. A 55.30 wt% of the arabinogalactan was retained in Ret-10 kDa, while Perm-10 kDa contained 20.21 wt%. After applying DF to Ret-10 kDa and Ret-1 kDa, both reduced their arabinogalactan retention despite the reuse of DF water in Ret-1 kDa. Ret-1 kDa-DF retained 2.47% and Ret-10 kDa-DF a moderate 37.46 wt%. The high extraction temperature resulted in a loss of low molecular weight arabinogalactan through Perm-1 kDa and DF waters of 39.86 wt%. This is similar to the value obtained for Feed-140 and Feed-160, so part of the autohydrolysed hemicelluloses was not lost but remained in the intermediate molecular weight product Perm-10 kDa.

3.3.2. Pectins

In the case of pectins, unlike arabinogalactan, all of them were distributed in the retentates for Feed-140. 94.77 wt% were recovered in Ret-30 kDa, while the rest were recovered in the following two retentates: Ret-10 kDa (1.65 wt%) and Ret-5 kDa (3.58 wt%). Pectins can be identified as high molecular weight components or at least associated with high molecular weight arabinogalactan, as already demonstrated in our previous work (Ramos-Andrés et al., 2020). Once the DF cycles were performed, the retention in Ret-30 kDa-DF was 74.92 wt%. Thanks to

the reuse of the DF water from the 30 kDa membrane, pectin retention was increased in the next membranes: Ret-10 kDa-DF (9.15 wt%), Ret-5 kDa-DF (10.45 wt%), and Ret-1 kDa-DF (5.48 wt%). The loss of pectins in the DF water and Perm-1 kDa was nil, so the recovery process was fully efficient. As can be seen in Table 3, products with pectins as major components and in different molecular weights were obtained, as pectins were present in higher proportion than arabinogalactan in Ret-10 kDa-DF, Ret-5 kDa-DF, and Ret-1 kDa-DF. Ret-30 kDa-DF, the product with the highest molecular weight, was more abundant in arabinogalactan.

Due to the higher extraction temperature, the pectins had a lower molecular weight at 160 than at 140 °C, with a lower percentage retained in the first membrane (71.08 wt%). While in the case of Feed-140 no pectin was lost through Perm-1 kDa, in the case of Feed-160 1.31 wt% were removed through this stream. In the other membranes, pectins were retained in percentages of 12.98 wt% (Ret-10 kDa), 7.03 wt% (Ret-5 kDa) and 7.60 wt% (Ret-1 kDa). The application of DF cycles kept the retention in Ret-30 kDa intact, so all pectins present there are either high molecular weight or bound to high molecular weight arabinogalactan. Retention in the next membranes was slightly reduced after DF, being in the range of 9.54–6.58 wt%. Compared to a zero-pectin loss in the case of Feed-140, in this case, the loss was a total of 6.04 wt%. According to the results very few pectins reach molecular weights of less than 1 kDa under these conditions.

Due to the high extraction temperature, Feed-180 had the lowest proportion of high molecular weight pectins, resulting in a recovery of 55.61 wt% at Ret-10 kDa. Certain pectins (9.96 wt%) were removed through DF of the 5 kDa membrane, the first membrane in the configuration. After the application of the DF cycles to Ret-10 kDa and Ret-1 kDa, a large part of the pectins retained as high molecular weight pectins were carried over in the DF water. Part of the pectins washed out in the 5 kDa DF water were recovered in the 1 kDa membrane DF, passing from 0 to 6.46 wt% in Ret-1 kDa-DF. The final retention of the other two products was 24.97 wt% in Ret-10 kDa-DF and 38.24 wt% in Perm-10 kDa. In this case, most of the pectins had an intermediate molecular weight. The total loss of pectins was 30.33 wt%, again lower than the loss of arabinogalactan but significantly higher than the pectins loss in Feed-140 and Feed-160.

3.3.3. Free sugars

Free sugars were not the target compounds in the present work, so they are intended to be poorly retained in the membranes. After performing UF of Feed-140, the retention of free sugars was 6.56 wt% in Ret-30 kDa and was in the range 14.38–15.53 wt% for Ret-10 kDa, Ret-5 kDa, and Ret-1 kDa. A total of 48.98 wt% was removed via Perm-1 kDa. This result shows the need for several cycles of DF to purify the biopolymers. After these cycles, the retention of free sugars became zero except for Ret-1 kDa-DF which retained a low 0.53 wt%. 50.49 wt% of the sugars were removed through the DF water. The total removal through Perm-1 kDa and DF waters was 99.47 wt%, very effective.

The retention of free sugars of Feed-160 was almost identical to the case of Feed-140, as can be seen in Table 2. The removal of free sugars via Perm-1 kDa was 42.66% versus 48.98% in the case of Feed-140. The total removal through Perm-1 and DF waters was 98.93%, resulting again in a very efficient purification process.

In the mixed configuration of Feed-180, very few sugars remained in the 10 kDa membrane products, as the previous 5 kDa membrane underwent DF cycles where 23.82 wt% of the sugars were removed along

with 56.53 wt% sent to Perm-1 kDa via Perm-5 kDa. The highest retention percentage occurred at Ret-1 kDa with 18.21 wt%. After the application of the DF cycles, the retention in the retentates was practically nil. Perm-10 kDa maintained a low 0.81 wt%. Sugars removed were 42.58 wt% through the DF waters. The total removed through Perm-1 kDa and the DF waters was 99.11 wt%, again very efficient even in the mixed rather than cascade configuration.

3.3.4. By-products

By-products are, together with free sugars, the components to be reduced in the treatment. In the case of Feed-140, by-products experienced higher retention in the membranes than free sugars, perhaps due to a higher interaction with the high molecular weight hemicelluloses and pectins. Only 20.27 wt% was removed by Perm-1 kDa, making DF cycles essential for purification. After these, only Ret-30 kDa-DF retained 3.71 wt% of the by-products, the remainder being removed through the DF waters. 96.29 wt% was removed through Perm-1 kDa and the DF waters.

The by-products experienced lower retention on the membranes in the case of Feed-160 than in the case of Feed-140, which may be due to the lower molecular weight of Feed-160 leading to less interaction with the by-products. By-products removal through Perm-1 kDa was 42.26 wt% in this case compared to 20.27 wt% in Feed-140. After application of the DF cycles, by-products retention was reduced to zero except for a small percentage in Ret-5 kDa-DF (0.75 wt%) and Ret-1 kDa-DF (0.01 wt%). The total removal through Perm-1 and DF waters was 99.24 wt%.

In the mixed configuration with Feed-180, a considerable proportion of by-products was removed via Perm-5 kDa and from there via Perm-1 kDa with a percentage of 66.24 wt%. In the 5 kDa DF, 9.18 wt% was removed, resulting in very low retention of by-products in the 10 kDa membrane. Ret-1 kDa was the product more abundant in by-products (18.17 wt%). After applying the DF cycles, the retentates were almost completely purified, with 28.11 wt% of the by-products being removed through the DF waters and a total of 94.35 wt% being removed through Perm-1 kDa and DF.

Both cascade and mixed configurations are suitable for purification based on the removal of free sugars and by-products. The loss of hemicelluloses and pectins was similar in both configurations, and the small differences can be attributed to the different extraction temperatures. An important difference between the two configurations is the number of products, which is lower in the mixed configuration as fewer membranes are used. Given the low proportion of biopolymers in the 10–30 kDa group, it may be more interesting to use fewer membranes. Due to the low proportion of hemicelluloses and pectins of intermediate molecular weight, a high percentage was not recovered in the reuse of the DF water. A mixed configuration seems more efficient with respect to resources (membranes, time, water) in view of the products obtained.

3.4. Separation applying UF and DF

It is possible to study the effect of separation not only in terms of individual components but also in terms of molecular groups. In Section 3.2, it was shown how each molecular group was more or less concentrated in the different retentates, and how DF decreased the concentration of the non-target groups. DF is key in the separation of molecular groups as well as in the purification of biopolymers. Fig. 4 shows the effect of separation due to UF but mainly due to DF showing the composition (wt%) of each molecular group in the feed and in the final

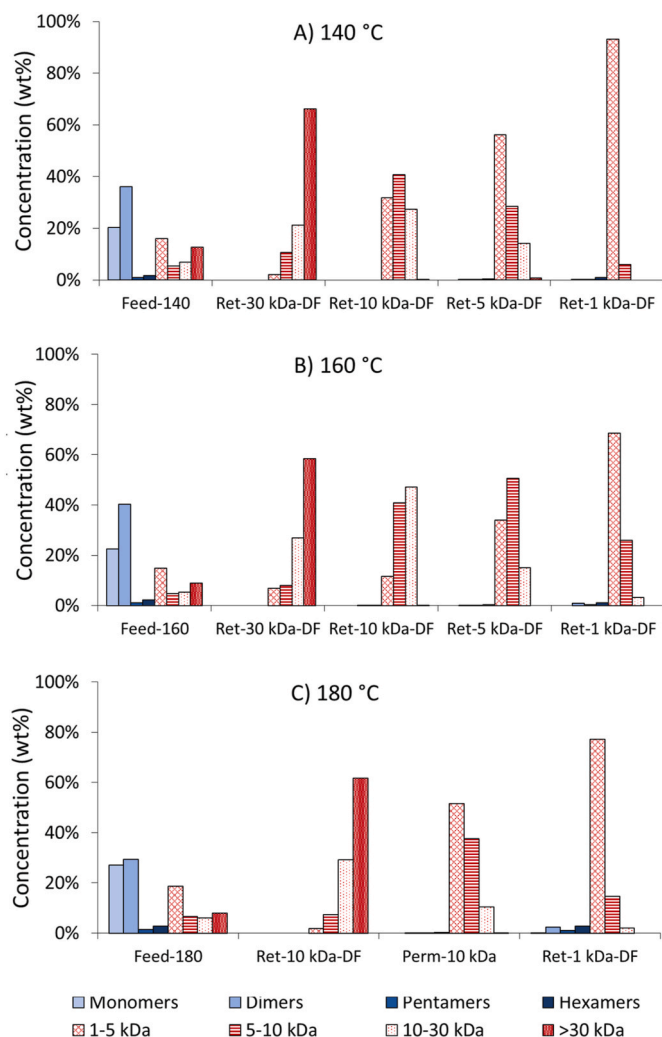

Fig. 4. Molecular weight distribution (wt%) of the Feed and the UF/DF products.

diafiltered products. A large difference can be seen in the molecular weight distribution of each product before and after the UF and DF cycles. In general, the presence of non-target components (<1 kDa) is practically null in all the products obtained. The maximum percentage reached was in the case of Ret-1 kDa-DF from Feed-180 where the hexamers reached 2.8 wt%.

In the cascade configuration with Feed-140 and Feed-160, Ret-30 kDa-DF products were rich in the > 30 kDa group with percentages of 66.2 wt% (140 °C) and 58.4 wt% (160 °C), as it can be seen in Fig. 4. These percentages were considerably higher than the percentage of > 30 kDa in the feeds, which was 12.7 wt% (140 °C) and 8.9 wt% (160 °C). The other molecular groups > 1 kDa were also present in Ret-30 kDa-DF in decreasing order according to their decreasing molecular weight. The Ret-10 kDa-DF product was rich in the 5–10 kDa group for 140 °C (40.8 wt%) and in the 10–30 kDa target group for 160 °C (47.2 wt%). The higher presence of 5–10 kDa than 10–30 kDa in Ret-10 kDa-DF at 140 °C could be due to the almost total retention of the 10–30 kDa group in the

30 kDa membrane even after applying DF (Fig. 3), not allowing the recovery of part of the 10–30 kDa group in the reuse of water in 10 kDa DF. The Ret-5 kDa-DF product of 140 °C contained the 1–5 kDa group as the most abundant (56.1 wt%) and the 5–10 kDa target group in the case of 160 °C (50.7 wt%). Again, the 5–10 kDa was considerably concentrated in Ret-30 kDa-DF at 140 °C compared to 160 °C and despite DF (Fig. 3). The last of the products, Ret-1 kDa-DF, was rich in both cases in the 1–5 kDa target group. The 1–5 kDa concentrations were 93.1 wt% (140 °C) and 68.6 wt% (160 °C). This difference could be due to slightly higher retention of the group in the 30 kDa membrane at 160 °C (Fig. 3).

When Feed-180 was processed in the mixed configuration, Fig. 4 shows that the first product Ret-10 kDa-DF was equivalent to Ret-30 kDa-DF and contained the group >30 kDa as the most abundant (61.7 wt%). The remaining molecular groups had a decreasing concentration as the molecular weight decreased. The next product was Perm-10 kDa, whose target group would be 5–10 kDa, but which was mostly in the 1–5 kDa group (51.6 wt%) partly because it was a permeate and no DF was applied. The last product was Ret-1 kDa-DF whose most abundant group was the target 1–5 kDa, with a concentration of 77.1 wt%. This value is intermediate to the obtained in Feed-140 and Feed-160, so there would be no notable differences in composition relative to obtaining this product in a cascade configuration or in a mixed configuration.

3.5. Chemical characterization and molecular weight distribution of the products

Table 3 shows the main parameters characterizing each of the downstream process streams. The main parameters defining the molecular weight distribution are MW and PD. As far as these parameters are concerned, the UF/DF system has made it possible to obtain fractions with MW within the desired range given the MWCO of the membranes used. DF allowed the PD value of the fractions to be reduced, some of them to almost a commercial level, improving separation and making these fractions more defined. At 140 °C, starting from a highly disperse feed (18.83 kDa, PD: 31.6), four well-defined fractions were obtained: Ret-30 kDa-DF (102.75 kDa, PD: 4.0), Ret-10 kDa-DF (8.06 kDa, PD: 1.6), Ret-5 kDa-DF (6.20 kDa, PD: 1.7) and Ret-1 kDa-DF (2.59 kDa, PD: 1.2). The fractions showed low polydispersity, which is advantageous for applications where a biopolymer with defined molecular weight and narrow distribution is required. At the other temperatures, the molecular weight distributions of the feeds were also polydisperse with values of 10.98 kDa PD: 19.9 (160 °C) and 9.02 kDa PD: 16.2 (180 °C). The products had similar molecular weights to those obtained at 140 °C, except for the highest molecular weight retentate, which had lower MW at higher extraction temperature. At 160 °C, the product parameters were Ret-30 kDa-DF (59.99 kDa, PD: 3.4), Ret-10 kDa-DF (11.48 kDa, PD: 1.5), Ret-5 kDa-DF (6.85 kDa, PD: 1.4) and Ret-1 kDa-DF (4.21 kDa, PD: 1.4). At 180 °C the three products obtained also had adequate values: Ret-10 kDa-DF (57.06 kDa, PD: 2.4), Perm-10 kDa (5.71 kDa, PD: 1.4) and Ret-1 kDa-DF (3.33 kDa, PD: 1.5).

As already mentioned, DF has the dual function of performing purification (removal of free sugars and by-products) and improving separation. This can be clearly seen in the increase of the MW value in the retentates after the application of the DF cycles. The removal of lower molecular weight hemicelluloses and pectins, and especially the removal of free sugars, resulted in this increase of the MW value accompanied by a decrease of the PD value as can be seen in Table 3.

Regarding the concentration of each component, Fig. 3 and Table 3 shows that the most concentrated products are those corresponding to the highest molecular weight fraction (Ret-30 kDa-DF) where the

Table 3

Characterization of the feeds, UF products and UF/DF products.

140 °C	MW (kDa)	PD	AG (mg/L)	Pectins (mg/L)	Free sugars (mg/L)	By-products (mg/L)	Bio-polymers (wt%)	AG/(AG + P)	G/A
Feed	18.83	31.6	592.7	289.59	1,765.4	175.5	31.25%	67.2%	1.51
Ret-30 kDa	54.57	51.6	1,895.8	1,372.22	688.6	487.4	73.54%	58.0%	1.50
Ret-30 kDa-DF	102.8	4.0	1,691.1	1,200.22	n.d.	32.5	98.89%	58.5%	1.74
Ret-10 kDa	1.04	2.4	229.2	29.78	1,713.8	297.8	11.41%	88.5%	3.89
Ret-10 kDa-DF	8.06	1.6	n.d.	183.26	n.d.	n.d.	100%	n.d.	n.d.
Ret-5 kDa	1.06	2.3	496.8	81.09	2,007.1	382.4	19.47%	86.0%	0.76
Ret-5 kDa-DF	6.20	1.7	94.27	261.54	n.d.	n.d.	100%	26.5%	1.83
Ret-1 kDa	0.61	1.4	278.4	n.d.	2,478.8	36.7	9.96%	100%	8.28
Ret-1 kDa-DF	2.59	1.2	78.51	171.48	92.19	n.d.	73.06%	31.4%	1.59
Perm-1 kDa	0.51	1.3	320.6	n.d.	2,110.9	86.8	12.73%	100%	1.22
160 °C	MW (kDa)	PD	AG (mg/L)	Pectins (mg/L)	Free sugars (mg/L)	By-products (mg/L)	Bio-polymers (wt%)	AG/(AG + P)	G/A
Feed	10.98	19.9	935.3	492.2	2,340.8	491.7	33.51%	65.5%	2.40
Ret-30 kDa	44.22	6.9	3,199.9	1,749.0	3,332.7	371.4	57.19%	64.7%	2.58
Ret-30 kDa-DF	59.99	3.4	2,768.6	1,729.2	68.52	n.d.	98.50%	61.6%	2.41
Ret-10 kDa	2.83	3.5	345.1	399.4	2,697.3	444.5	21.63%	46.4%	2.16
Ret-10 kDa-DF	11.48	1.5	82.09	293.4	n.d.	n.d.	100%	21.9%	1.43
Ret-5 kDa	1.97	3.7	409.2	270.4	2,961.3	485.6	16.47%	60.2%	1.70
Ret-5 kDa-DF	6.85	1.4	115.9	260.3	29.25	28.91	86.61%	30.8%	1.79
Ret-1 kDa	1.28	2.7	527.0	365.5	3,404.5	520.3	18.53%	59.0%	1.37
Ret-1 kDa-DF	4.21	1.4	333.0	316.2	72.52	0.41	89.90%	51.3%	1.45
Perm-1 kDa	0.54	1.4	326.6	15.73	2,437.8	507.4	10.41%	95.4%	2.68
180 °C	MW (kDa)	PD	AG (mg/L)	Pectins (mg/L)	Free sugars (mg/L)	By-products (mg/L)	Bio-polymers (wt%)	AG/(AG + P)	G/A
Feed	9.02	16.2	1,516.5	685.8	4,061.2	1,049.1	30.12%	68.9%	3.13
Ret-5 kDa	11.20	20.7	568.0	3,429.1	5,129.7	817.9	60.49%	62.3%	2.15
Ret-5 kDa-DF	30.58	4.1	5,875.5	3,087.6	293.3	98.66	95.81%	65.6%	2.61
Ret-10 kDa	38.91	3.8	21,516.3	9,534.9	836.6	386.6	96.21%	69.3%	3.12
Ret-10 kDa-DF	57.06	2.4	14,202.5	4,281.9	n.d.	48.33	99.74%	76.8%	2.17
Perm-10 kDa	5.71	1.4	1,965.3	1,475.8	161.3	319.9	87.73%	57.1%	1.69
Ret-1 kDa	0.99	2.3	896.8	n.d.	4,865.8	947.4	13.37%	100%	18.81
Ret-1 kDa-DF	3.33	1.5	234.0	277.1	21.31	n.d.	96.00%	45.8%	1.07
Perm-1 kDa	0.53	1.6	371.2	n.d.	3,798.1	874.8	7.36%	100%	n.d.

MW: weight-average molecular weight, PD: polydispersity, AG: arabinogalactan, P: pectins, G: galactan, A: arabinan.

concentration of arabinogalactan and pectins increased with respect to the feed by 2.65 and 4.15-fold (cascade configuration, 140 °C), 2.96 and 3.51-fold (cascade configuration, 160 °C), and 9.37 and 6.24-fold (mixed configuration, 180 °C). The rest of the products had a similar or slightly lower concentration than the feed, but very good characteristics. The concentration of free sugars and by-products can also be seen in Table 3, and the values show the importance of DF in minimizing their presence. The purity of the products obtained was defined as the ratio of the concentration of biopolymers to the total concentration. The purity values were high, being for 140 °C in the range 73.06–100 wt%, for 160 °C between 86.61 and 100 wt%, and for 180 °C between 87.73 and 100 wt%. The improvement in purity was remarkable as the feed purity values were 31.49 wt% (Feed-140), 33.51 wt% (Feed-160), and 30.12 wt% (Feed-180).

Another parameter of interest was whether the product was more abundant in arabinogalactan or pectin. In the case of Feed-140, corresponding to the lowest extraction temperature, Table 3 shows that arabinogalactan was only predominant in the highest molecular weight retentate with 58.5 wt%. The rest of the retentates were mostly pectins with values between 68.6 and 100 wt%. These values represent pectin of commercial quality, as it exceeds the 65 wt% of homogalacturonan required in the market (Schmidt et al., 2017). In the Feed-160 treatment, the retentates more abundant in arabinogalactan were the highest and lowest molecular weight, with percentages of 61.6 wt% (Ret-30 kDa-DF) and 51.3 wt% (Ret-1 kDa-DF). The result is logical due to a higher breakdown of hemicelluloses by autohydrolysis. The other two retentates were again mostly pectins with percentages between 69.2 and 78.1 wt%, again commercial values. The Feed-180 treatment resulted in the highest molecular weight product being rich in arabinogalactan (76.8 wt%). The intermediate product, Perm-10 kDa, was also rich in arabinogalactan due to autohydrolysis, with a percentage of 57.1 wt%. The lower molecular weight product, Ret-1 kDa-DF, was instead major in

pectins with a percentage of 54.2 wt%.

The G/A is defined as the ratio between galactan and arabinan in arabinogalactan, and it can be related to the molecular weight. In general, the lower molecular weight, the higher the G/A ratio. This is due to the release of monomeric arabinose units into the medium as a result of autohydrolysis. The higher the temperature, the higher the G/A value. Once the DF cycles are performed, this G/A ratio did not follow a fixed rule as it decreased on some occasions and increased on others. This may be because the hemicellulose fragments removed during DF contain both galactose and arabinose units, not exclusively monomeric arabinose units.

According to the results shown in Table 3, the technological feasibility of the process of obtaining different purified fractions of hemicelluloses/pectins was proven. It would be necessary to determine the economic feasibility. The membrane operation offers low cost compared to other purification processes requiring chemicals or operating conditions not close to the environment (e.g., ethanol precipitation or chromatography). In the membrane operation, the only chemical needed was NaOH in low concentration (0.01 M) for cleaning after the operation. The main expense of the process was pumping for the duration of the UF or DF. This time would be reduced if the permeate flow were higher, which could be achieved with proper scaling. The other main cost was water consumption in the DF process. As shown in Fig. 1, part of this water was reused in the process, not only to partially recover the entrained hemicelluloses/pectin but also to consume less resource. One possibility would be the implementation of a nanofiltration membrane for the purification of water obtained in Perm-1 kDa and its subsequent reuse. The implementation of the process on an industrial scale would require a proper economic assessment to confirm feasibility.

Since the different extracts were treated with different membrane configurations, it was not possible to establish an optimum operation. Both configurations (cascade and mixed) are feasible, and the mixed

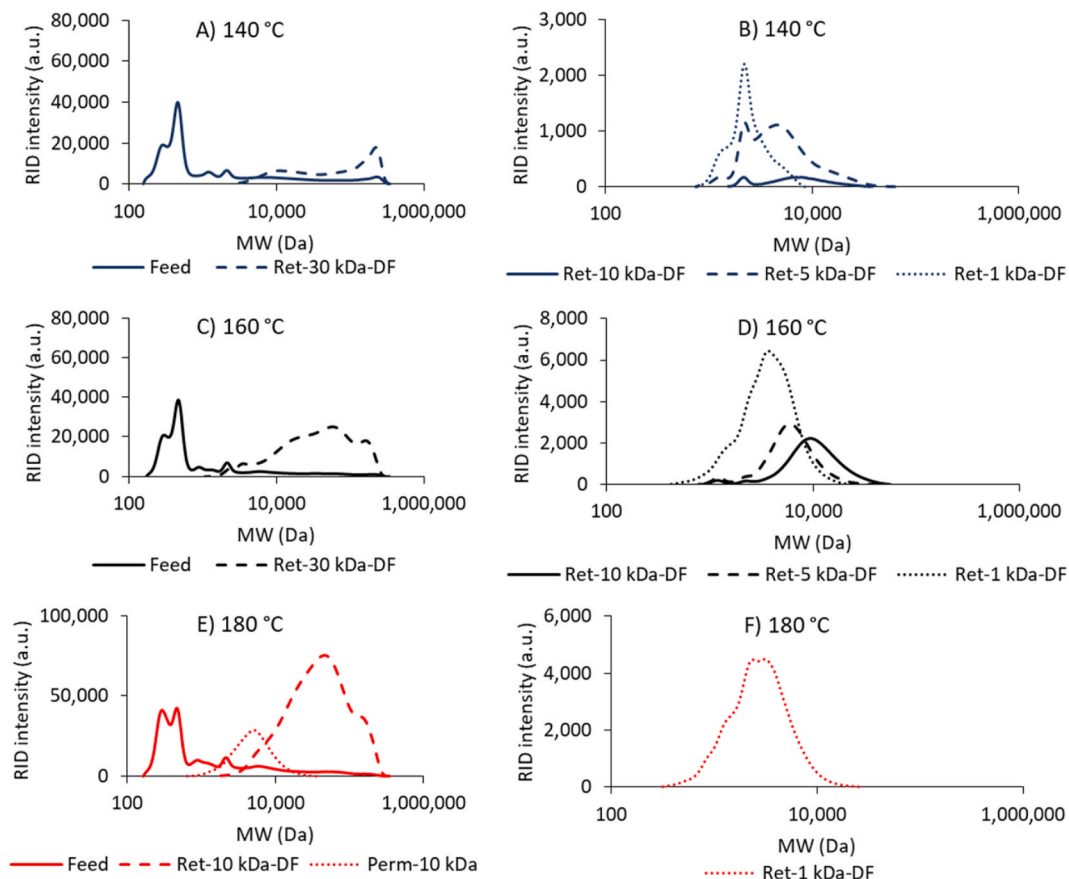

Fig. 5. Molecular weight distribution curves of the feed and the UF/DF products.

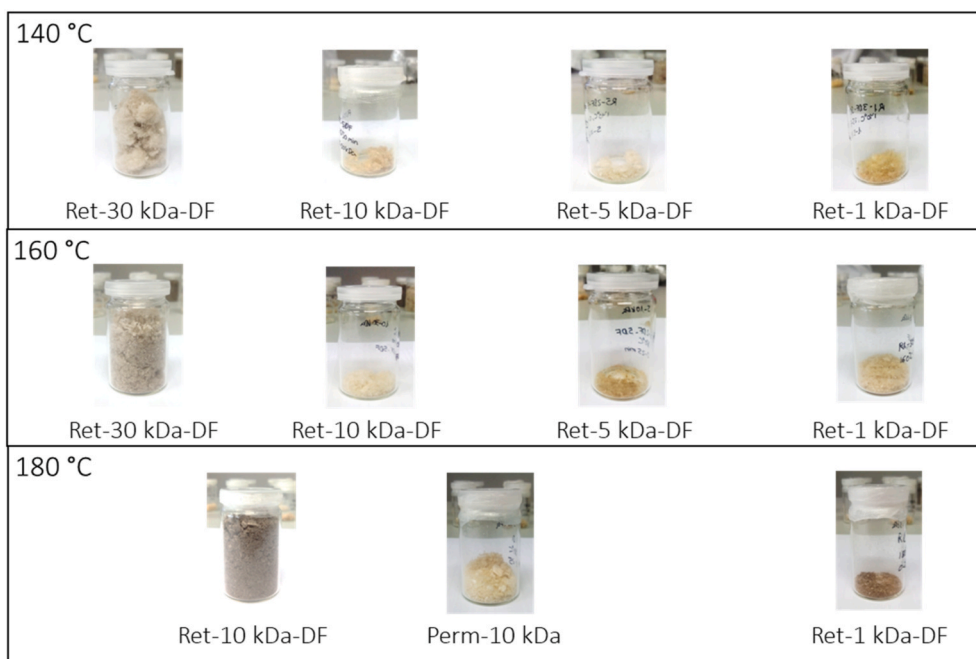

Fig. 6. Purified hemicellulose/pectin products after freeze-drying.

operation has the advantage of providing a higher concentration of the highest molecular weight product. Because the cascade configuration showed the existence products of very low concentration (e.g. 10–30 kDa), it may be interesting to discard this fraction and obtain a low

number as in the mixed configuration.

Fig. 5 shows the molecular weight distribution curves of the feed and diafiltered products. These curves allow seeing graphically what the MW and PD parameters indicate. Starting from very broad molecular

distributions in all three cases (140, 160, and 180 °C), a clearly more concentrated product was obtained (the area under the curve is larger) with the higher molecular weight biopolymers. This product was Ret-30 kDa-DF for 140 and 160 °C, and Ret-10 kDa-DF for 180 °C. The next product, of lower concentration, was Perm-10 kDa from Feed-180, which had a clearly narrow and well-defined distribution, centered in the 5–10 kDa range. The less concentrated products are shown in the graphs on the right. All of them also had a narrow distribution, as the PD value was low. Within these products, the lowest molecular weight product (Ret-1 kDa-DF) was the most concentrated in all three cases, as it corresponds to the easily extractable arabinogalactans (Ramos-Andrés et al., 2020). One peak stood out in the products from Feed-140, and it was associated with a molecular weight of around 2.25 kDa. Given the high proportion of pectins in these products, this peak could be associated with them, being a type of pectin of lower molecular weight as previously demonstrated (Ramos-Andrés et al., 2020).

3.6. Structural characterization of the products

Structural characterization was applied to the purified products after freeze-drying. Fig. 6 shows these solid products. The highest molecular weight retentates had the darkest colour, and the samples with the highest pectin content had the lightest colour. The higher the extraction temperature, the darker the colour of the hemicelluloses/pectin. The most abundant product was the fraction with the highest molecular weight.

3.6.1. FTIR

The ATR-FTIR spectra of the most abundant purified products were determined after freeze-drying and they can be seen in Figure A1. These products were Ret-30 kDa-DF, Ret-5 kDa-DF, and Ret-1 kDa-DF for Feed-140 and Feed-160, and Ret-10 kDa-DF, Perm-10, kDa and Ret-1 kDa-DF for Feed-180. The broad band in 3,600–3,000 cm^{-1} is associated with the hydroxyl group of O–H stretching vibrations, characteristic of lignocellulosic materials. The intensity in this area was similar for all products. The region between 3,000–2,800 cm^{-1} is related to C–H stretching vibrations. This type of bond is present in both hemicelluloses and pectins as it is present in their constituent monosaccharides. The intensity was the same for all products except in A) 140 °C, where the lower the molecular weight of the products, the higher the intensity. This may be due to a lower branching or higher linearity of these lower molecular weight fractions.

The band 1,800–1,500 cm^{-1} represents carbonyl groups (C=O) stretching vibrations. The peak 1,738 cm^{-1} is associated with the presence of the C=O methyl ester group (COOCH₃) corresponding to pectin structure (Ben-Fadhel et al., 2020). In the case of A) 140 °C, this peak was significantly lower for the product with the lowest molecular weight (Ret-1 kDa-DF), so the lower molecular weight pectins have a lower degree of methylation. In B) 160 °C, the intensity of the peak was similar for all three products, although slightly higher for the highest molecular weight (Ret-30 kDa-DF). In the C) 180 °C products, the peak was of lower intensity for Ret-10 kDa-DF and Ret-1 kDa-DF compared to the intermediate molecular weight product (Perm-10 kDa). The high extraction temperature (180 °C) might have decreased the degree of methylation in the higher molecular weight pectins (Ret-10 kDa-DF). The peak at 1,602 cm^{-1} is assigned to the stretching vibration of the carbonyl group of the carboxylate ion (COO⁻), corresponding to the hemicellulose and especially to the pectin structure (Sucheta et al., 2019). In the cases of A) 140 °C and B) 160 °C, this peak was higher in the intermediate molecular weight product (Ret-5 kDa-DF) and lower in the highest molecular weight (Ret-30 kDa-DF), so the lower the molecular weight, the higher the presence of the COO⁻ group. Ret-1 kDa-DF was not the sample with the highest intensity which may be due to its lower pectin content compared to Ret-5 kDa-DF. In the case of C) 180 °C, the intensity of the peak was always higher the lower the molecular weight, as in this case the pectin content was similar in Perm-10 kDa and

Ret-1 kDa-DF.

The band between 1,500–1,200 cm^{-1} includes the peaks 1,401, 1,358, and 1,228 cm^{-1} . The peak 1,401 cm^{-1} is again related to the carboxylic acid and COO⁻ symmetric stretching vibration in hemicellulose and pectin (Célino et al., 2013). This peak follows the same trend as the 1,602 cm^{-1} peak also associated with the COO⁻ stretching vibration. The peak 1,358 cm^{-1} is assigned to C–H deformation in hemicellulose and pectin (Traoré et al., 2016). The intensity of this peak was lower the higher the molecular weight of the product, which again could be associated with a higher branching of the biopolymers of high molecular weight and a lower presence of the C–H bond. The peak 1,228 cm^{-1} is due to C–OH bending at C6 so it is relating with pyranose ring vibration (Fan et al., 2012). This is due to the sugar galactose.

The region 1,200–950 cm^{-1} contains multiple peaks associated with polysaccharides. These peaks are related to C–C, C–OH-, C–O–C, C–H ring, and side group vibrations (Fan et al., 2012). The band 1,200–1,100 cm^{-1} is related to C–O–C stretching vibration in the glycosidic ring (Ben-Fadhel et al., 2020). There were no notable differences in products in this region. The region 1,100–950 cm^{-1} implies C–C, C–O, and C–OH stretching vibrations (Ben-Fadhel et al., 2020). In this region, there was an area with peaks reminiscent of the shape of a saw blade. These peaks are more pronounced in samples with a higher percentage of pectins. The peak at 1,007 cm^{-1} stood out, whose intensity was maximum in the product with the highest molecular weight in A) 140 °C and B) 160 °C (Ret-30 kDa-DF). For C) 180 °C the intensity was higher in the intermediate molecular weight product (Perm-10 kDa). This could be due to, as in the case of the 1,738 cm^{-1} peak, the extraction temperature of 180 °C may have decreased the presence of these bonds in the highest molecular weight hemicelluloses and pectins (Ret-10 kDa-DF).

3.6.2. TGA

The first derivative of the weight loss curve shows peaks representing the greatest rates of change on the weight loss curve, which are the inflection points in the weight loss curve. By plotting the first derivative, the temperature corresponding to each peak can be seen. Figure A2. A) shows the most abundant products obtained from Feed-140: Ret-30 kDa-DF, Ret-5 kDa-DF, and Ret-1 kDa-DF. The same products but from Feed-160 are represented in Figure A2. B), while Figure A2. C) shows the products Ret-10 kDa-DF, Perm-10 kDa, and Ret-1 kDa-DF from Feed-180.

In Figure A2. A), three peaks can be seen: the first one is found in all three products in the range 77.0–132.70 °C and represents the evaporation of the water present in the sample, being between 5.71 and 8.51 wt% of the sample content. The next peak of decomposition is also present in all three products, in the range 202.02–226.08 °C. This peak can be associated with the decomposition of a significant part of the sample, which constitutes 19.59 wt% for Ret-30 kDa-DF versus 57.59 wt% for Ret-5 kDa-DF and 55.39 wt% for Ret-1 kDa-DF. This peak can be associated with hemicelluloses and pectins easier to thermally degrade. On the contrary, the Ret-30 kDa-DF sample has a third peak at 274.89 °C, where 45.67 wt% of the sample decomposes. This peak could be associated with higher molecular weight hemicelluloses and/or pectins, not present in the other two samples and more resistant to thermal decomposition given the results of the analysis.

The same happens in Figure A2. B) with the products from Feed-160. All three products have a first peak in the range 76.35–76.92 °C representing water evaporation. This is followed by a peak in the range 209.73–237.62 °C, representing the decomposition of certain hemicelluloses/pectins with percentages of 14.56 wt% (Ret-30 kDa-DF) versus 57.61 wt% (Ret-5 kDa-DF) and 62.32 wt% (Ret-1 kDa-DF). The last peak is associated with those more resistant biopolymers whose main decomposition occurs at 277.27 °C. This peak is present only in Ret-30 kDa-DF with a percentage of 52.99 wt%.

The products from Feed-180 shown in Figure A2. C) show a similar result. There is a first peak in the range 76.21–77.07 °C which represents the evaporation of water from the sample. The next peak is in the range

215.99–229.08 °C, and unlike the previous peaks is present only in Perm-10 kDa and Ret-1 kDa-DF products, with percentages of 68.29 and 63.63 wt%. The higher molecular weight product Ret-10 kDa-DF has a single decomposition peak at 286.52 °C, with a percentage of 66.26 wt%. The absence of the second peak (approx. 222 °C) could be due to the high extraction temperature, so this group of hemicelluloses and pectins became present only in the other two products (Perm-10 kDa and Ret-1 kDa-DF) instead of Ret-10 kDa-DF. This is consistent with the Ret-30 kDa-DF product of Feed-160 having a lower percentage of this biopolymer group than the Ret-30 kDa-DF product of Feed-140: 14.56 wt% versus 19.59 wt%. The presence of different groups of hemicelluloses and pectins can also be seen well in the molecular weight distribution curves in Fig. 5.

4. Conclusions

Purified solid fractions of different molecular weights and low polydispersity were obtained from the three hydrothermal extracts of discarded carrots (140, 160, and 180 °C). There were no notable differences between the cascade configuration and the mixed configuration, except for the number of membranes used and the degree of concentration of the highest molecular weight biopolymers which can be up to 5 times higher in the mixed configuration than in the cascade configuration. The purification allowed eliminating a very high percentage of free sugars (up to 99.5 wt%) and by-products (up to 99.2 wt%), resulting in fractions with purities between from 73.1 to 100 wt%. The treatment resulted in fractions with molecular weights between 2.59 and 102.75 kDa and with low polydispersity between 1.2 and 4.0 due to successive DF steps. The purified fractions were preserved using freeze-drying for subsequent application in film formation. This allows the production of plastic substitute products in a clean way from the point of view of both process and raw material. The film formation work is in the process of being published.

CRedit authorship contribution statement

Marta Ramos-Andrés: Conceptualization, Methodology, Validation, Formal analysis, Investigation, Writing – original draft, Visualization. **Beatriz Aguilera-Torre:** Validation, Investigation. **Juan García-Serna:** Supervision, Correct-Original Draft, Graphical Abstract, Project administration, Funding acquisition.

Declaration of competing interest

The authors declare that they have no known competing financial interests or personal relationships that could have appeared to influence the work reported in this paper.

Acknowledgments

The authors thank the Spanish Ministry of Science, Innovation, and Universities, the Spanish Ministry of Economy and Competitiveness, and FEDER Funds EU for funding, projects' reference: CLU-2019-04 (Consejería de Educación, Junta de Castilla y León, FEDER, EU) and PID2019-105975GB-I00 (MICINN/FEDER, EU). Marta Ramos-Andrés wish to thank the Spanish Ministry of Education, Culture and Sports for the research-university professor training contract (reference FPU15/06366). The authors wish also to thank the company Muñozval S.L. for the raw material supply and the advice.

Appendix A. Supplementary data

Supplementary data to this article can be found online at <https://doi.org/10.1016/j.jclepro.2021.128923>.

References

- Al Manasrah, M., Kallioinen, M., Ilvesniemi, H., Mänttari, M., 2012. Recovery of galactoglucomannan from wood hydrolysate using regenerated cellulose ultrafiltration membranes. *Bioresour. Technol.* 114, 375–381. <https://doi.org/10.1016/j.biortech.2012.02.014>.
- Arkel, A., Krawczyk, H., Jönsson, A.S., 2013a. Influence of heat pretreatment on ultrafiltration of a solution containing hemicelluloses extracted from wheat bran. *Separ. Purif. Technol.* 119, 46–50. <https://doi.org/10.1016/j.seppur.2013.09.001>.
- Arkel, A., Krawczyk, H., Thuvander, J., Jönsson, A.S., 2013b. Evaluation of membrane performance and cost estimates during recovery of sodium hydroxide in a hemicellulose extraction process by nanofiltration. *Separ. Purif. Technol.* 118, 387–393. <https://doi.org/10.1016/j.seppur.2013.07.015>.
- Babbar, N., Roy, S. Van, Wijnants, M., Dejonghe, W., Caligiani, A., Sforza, S., Elst, K., 2016. Effect of extraction conditions on the saccharide (neutral and acidic) composition of the crude pectic extract from various agro-industrial residues. *J. Agric. Food Chem.* 64, 268–276. <https://doi.org/10.1021/acs.jafc.5b04394>.
- Ben-Fadhel, Y., Maherani, B., Manus, J., Salmieri, S., Lacroix, M., 2020. Physicochemical and microbiological characterization of pectin-based gelled emulsions coating applied on pre-cut carrots. *Food Hydrocolloids* 101, 105573. <https://doi.org/10.1016/j.foodhyd.2019.105573>.
- Céline, A., Fréour, S., Jacquemin, F., Casari, P., 2013. Characterization and modeling of the moisture diffusion behavior of natural fibers. *J. Appl. Polym. Sci.* 130, 297–306. <https://doi.org/10.1002/app.39148>.
- Dranca, F., Oroian, M., 2018. Extraction, purification and characterization of pectin from alternative sources with potential technological applications. *Food Res. Int.* 113, 327–350. <https://doi.org/10.1016/j.foodres.2018.06.065>.
- Fan, M., Dai, D., Huang, B., 2012. Fourier transform infrared spectroscopy for natural fibres. In: *Fourier Transform - Materials Analysis*. <https://doi.org/10.5772/35482>.
- González-Muñoz, M.J., Rivas, S., Santos, V., Parajó, J.C., 2013. Fractionation of extracted hemicellulosic saccharides from Pinus pinaster wood by multistep membrane processing. *J. Membr. Sci.* 428, 281–289. <https://doi.org/10.1016/j.memsci.2012.10.021>.
- Grassino, A.N., Barba, F.J., Brncić, M., Lorenzo, J.M., Lucini, L., Brncić, S.R., 2018. Analytical tools used for the identification and quantification of pectin extracted from plant food matrices, wastes and by-products: a review. *Food Chem.* 266, 47–55. <https://doi.org/10.1016/j.foodchem.2018.05.105>.
- Grassino, A.N., Halambek, J., Djaković, S., Rimac Brncić, S., Dent, M., Grabarić, Z., 2016. Utilization of tomato peel waste from canning factory as a potential source for pectin production and application as tin corrosion inhibitor. *Food Hydrocolloids* 52, 265–274. <https://doi.org/10.1016/j.foodhyd.2015.06.020>.
- Jafari, F., Khodaiyan, F., Kiani, H., Hosseini, S.S., 2017. Pectin from carrot pomace: optimization of extraction and physicochemical properties. *Carbohydr. Polym.* 157, 1315–1322. <https://doi.org/10.1016/j.carbpol.2016.11.013>.
- Krawczyk, H., Persson, T., Andersson, A., Jönsson, A.S., 2008. Isolation of hemicelluloses from barley husks. *Food Bioprod. Process.* 86, 31–36. <https://doi.org/10.1016/j.fbp.2007.10.018>.
- Laine, C., Kempainen, K., Kuutti, L., Varhimo, A., Asikainen, S., Grönroos, A., Määttä, M., Buchert, J., Harlin, A., 2015. Extraction of xylan from wood pulp and brewer's spent grain. *Ind. Crop. Prod.* 70, 231–237. <https://doi.org/10.1016/j.indcrop.2015.03.009>.
- Marić, M., Grassino, A.N., Zhu, Z., Barba, F.J., Brncić, M., Rimac Brncić, S., 2018. An overview of the traditional and innovative approaches for pectin extraction from plant food wastes and by-products: ultrasound-, microwave-, and enzyme-assisted extraction. *Trends Food Sci. Technol.* 76, 28–37. <https://doi.org/10.1016/j.tifs.2018.03.022>.
- Persson, T., Krawczyk, H., Nordin, A.K., Jönsson, A.S., 2010. Fractionation of process water in thermomechanical pulp mills. *Bioresour. Technol.* 101, 3884–3892. <https://doi.org/10.1016/j.biortech.2009.12.142>.
- Raji, Z., Khodaiyan, F., Rezaei, K., Kiani, H., Hosseini, S.S., 2017. Extraction optimization and physicochemical properties of pectin from melon peel. *Int. J. Biol. Macromol.* 98, 709–716. <https://doi.org/10.1016/j.jbiomac.2017.01.146>.
- Ramos-Andrés, M., Aguilera-Torre, B., García-Serna, J., 2020. Hydrothermal production of high-molecular weight hemicellulose-pectin, free sugars and residual cellulose pulp from discarded carrots. *J. Clean. Prod.* 125179. <https://doi.org/10.1016/j.jclepro.2020.125179>.
- Ramos-Andrés, M., Andrés-Iglesias, C., García-Serna, J., 2019. Production of molecular weight fractionated hemicelluloses hydrolyzates from spent coffee grounds combining hydrothermal extraction and a multistep ultrafiltration/diafiltration. *Bioresour. Technol.* 292, 121940. <https://doi.org/10.1016/j.biortech.2019.121940>.

- Ribas-Agustí, A., Van Buggenhout, S., Palmero, P., Hendrickx, M., Van Loey, A., 2014. Investigating the role of pectin in carrot cell wall changes during thermal processing: a microscopic approach. *Innovat. Food Sci. Emerg. Technol.* 24, 113–120. <https://doi.org/10.1016/j.ifset.2013.09.005>.
- Rico, X., Gullón, B., Alonso, J.L., Parajó, J.C., Yáñez, R., 2018. Valorization of peanut shells: manufacture of bioactive oligosaccharides. *Carbohydr. Polym.* 183, 21–28. <https://doi.org/10.1016/j.carbpol.2017.11.009>.
- Rojas, A.M., Basanta, M.F., De'Nobili, M.D., Idrovo Encalada, A.M., Fissore, E.N., 2015. Carrot fiber (CF) composite films for antioxidant preservation: particle size effect. *Carbohydr. Polym.* 136, 1041–1051. <https://doi.org/10.1016/j.carbpol.2015.09.109>.
- Schmidt, U.S., Schütz, L., Schuchmann, H.P., 2017. Interfacial and emulsifying properties of citrus pectin: interaction of pH, ionic strength and degree of esterification. *Food Hydrocolloids* 62, 288–298. <https://doi.org/10.1016/j.foodhyd.2016.08.016>.
- Sucheta, Chaturvedi, K., Yadav, S.K., 2019. Ultrasonication assisted salt-spices impregnation in black carrots to attain anthocyanins stability, quality retention and antimicrobial efficacy on hot-air convective drying. *Ultrason. Sonochem.* 58, 104661. <https://doi.org/10.1016/j.ultsonch.2019.104661>.
- Sukhbaatar, B., Hassan, E.B., Kim, M., Steele, P., Ingram, L., 2014. Optimization of hot-compressed water pretreatment of bagasse and characterization of extracted hemicelluloses. *Carbohydr. Polym.* 101, 196–202. <https://doi.org/10.1016/j.carbpol.2013.09.027>.
- Thuvander, J., Jönsson, A.S., 2020. Techno-economic impact of air sparging prior to purification of alkaline extracted wheat bran hemicelluloses by membrane filtration. *Separ. Purif. Technol.* 253 <https://doi.org/10.1016/j.seppur.2020.117498>, 0–4.
- Traoré, M., Kaal, J., Martínez Cortizas, A., 2016. Application of FTIR spectroscopy to the characterization of archeological wood. *Spectrochim. Acta Part A Mol. Biomol. Spectrosc.* 153, 63–70. <https://doi.org/10.1016/j.saa.2015.07.108>.