

# A Simulation of Fuzzy Logic Based Fuel Control Unit on Aircraft Engine System

A.Ramaniya and Suprijadi

Research Division Of High Energy Theoretical Physics And Instrumentation

Faculty Of Mathematics and Natural Sciences

Institut Teknologi Bandung

Jl.Ganesha 10 Bandung 40132

[supri@fi.itb.ac.id](mailto:supri@fi.itb.ac.id)

## Abstract

Gas turbine engine plays an important role in many technical areas such as aviation engine and power turbine generator. The basic fundamental of this engine is to maintain stability of the engine rotation speed (RPM) during all cycle of engine operation. To control the rpm, a Fuel Control Unit is installed. This device controls the rpm and also the fuel flow consumption through a fuel injector in the combustion chamber. In the past decade, the pneumatic fuel control unit is starting to be replaced by electronic fuel control unit. An electronic fuel control unit is believed to have better performance compared to pneumatic controllers. In this paper, a simulation of a fuzzy logic based fuel control unit on Allison Bendix 250 engine was done using MATLAB 7.0. From this simulation, it can be observed that the fuzzy logic based fuel control unit was able to stabilize the engine under disturbances. Results of this simulation will be discussed in this paper.

*Keywords: Gas Turbine Engine, Allison Bendix 250, Fuzzy Logic, Fuel Control Unit, RPM, Fuel Flow.*

## 1 Introduction

Automatic control is becoming more and more important in this age of automation. The duty of control engineering is to bring these parameters to certain pre-defined values (set point), and to maintain them constant against all disturbing influences. During the past decade, electronic control unit has started to replace mechanical control unit, since it was believed to have a better performance and much simpler to design. Despite its rapid development, control system is still the biggest problem in all fields. This was caused because the difficulty level of a control system will increase according to the difficulty to solve a problem. The merge of control system with artificial intelligence was a method to simplify the difficulty level of designing a control system.

As one of the methods in artificial intelligence, Fuzzy Logic was a popular choice. Fuzzy control is a practical alternative for a variety of challenging control applications since it provides a convenient method for constructing nonlinear controllers via the use of heuristic information. One of the applications of a control system was on aircraft automation system. Included in this aircraft automation system is a fuel control system. In the past years, a lot of non-conventional approaches to control a gas turbine aero-engine were investigated. The rationale behind this study is the need to develop advanced tools and techniques that can assist in improving this paper. This paper has an objective to simulate a fuzzy logic based fuel control unit on the Allison Bendix 250 engine.

The Allison 250 series turbo shaft engine consists of a compressor assembly, combustion assembly, turbine assembly, and accessory gearbox assembly. The 250 series turbo shaft engine, being an internal combustion engine, requires intake, compression, combustion,

and exhaust as does a reciprocating engine. The result of this simulation would determine the whether fuzzy logic is a suitable alternative for fuel control unit. Performance of the system and simultaneously enhance the flexibility of the control strategy.

## 2 Fuel Control System on Alisson Bendix 250

The Fuel system on Allison Bendix 250 is consisted of Fuel Pump Assembly, Gas Producer Fuel Control, Power Turbine Governor and Fuel Nozzle (see Figure 1). The fuel system meters fuel during all cycle of the engine operations to make sure the right amount of fuel was supplied to engine in respect to the appropriate cycle. The gas producer fuel control and power turbine governor provide speed governing of the power turbine rotor and over speed protection for the gas producer rotor system.

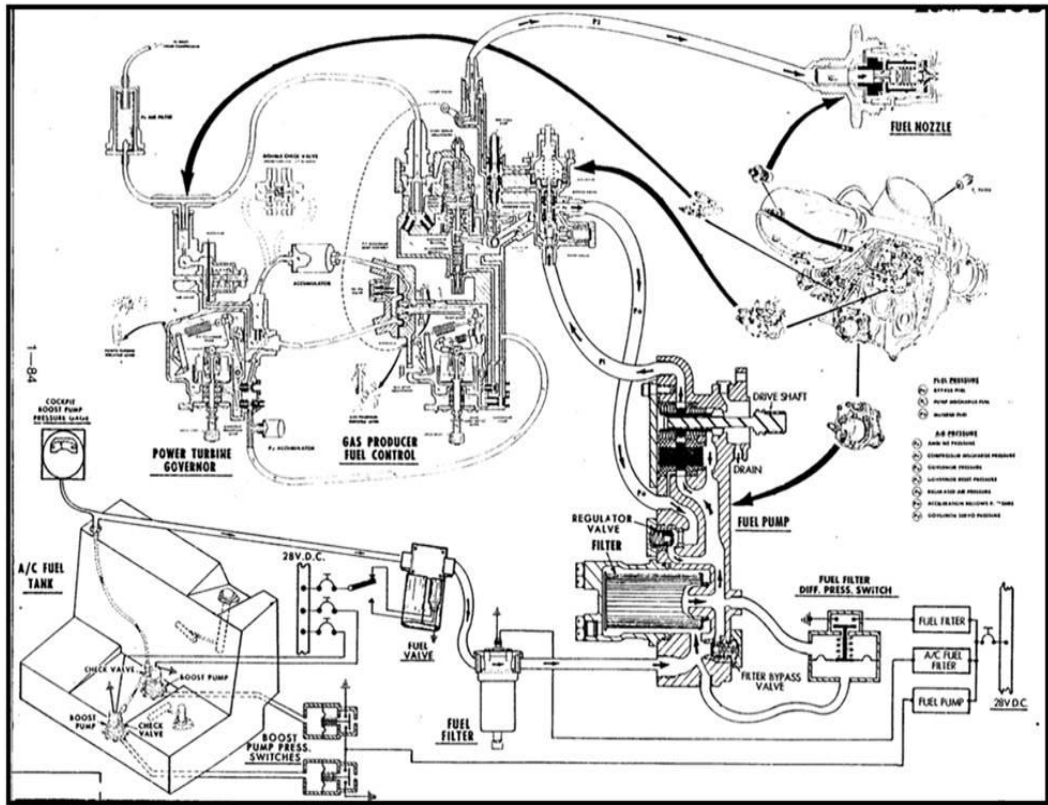

Figure 1 Fuel system schematic

The fuel control system is pneumatic-mechanical and sense  $N_1$  and  $N_2$  speeds, compressor discharge air pressure ( $P_c$ ), and twist grip position to regulate and maintain fuel flow within established limits. These limits depend on which cycle the engine is on. The basic engine operation cycle can be classified as follows:

Operation	Input	Output
Starting	N <sub>1</sub> RPM=15 %, Pc increased	Fuel flow reduced
Acceleration	N <sub>1</sub> RPM=52%-62.6%, Pc increased, twist grip=ground idle.	Fuel flow increased
Ground idle	N <sub>1</sub> RPM approximately 62%, N <sub>2</sub> RPM less than 100%, twist grip= ground idle.	Fuel flow reduced
Enrichment	N <sub>1</sub> RPM=62.6%-74.3% or 82%, N <sub>2</sub> RPM=less than 100%, Pc= 31 PSIA, twist grip= ground idle to fully open	Fuel flow increased
Stabilized on air	N <sub>1</sub> RPM=103%, N <sub>2</sub> RPM= approxima-tely 100%, Pc increased, twist grip=fully open	Fuel flow reduced and stabilized.

### 3 The Design of Fuzzy Logic Based Fuel Control System

The basic idea of this control system was to control the N1 RPM error, in order to control the fuel flow. Figure 2 shows the general system design.

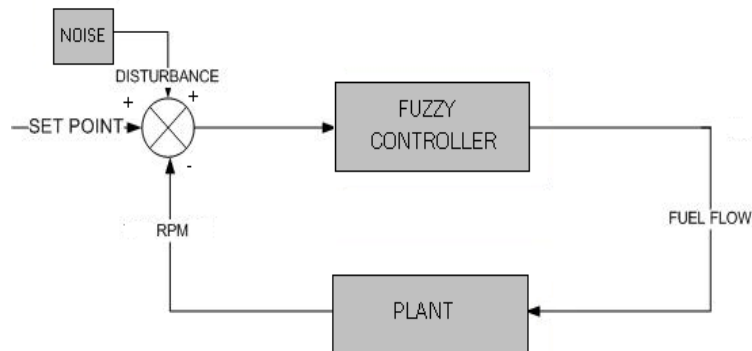

Figure 2 General system design

There were two different plants, each plant simulated different condition of the aircraft engine cycle. The data used in order to create the simulation was obtained during an engine testing. These data were then plotted into two separate graphics based on the engine condition each plant was representing. The resulted function was used to create the plant simulation.

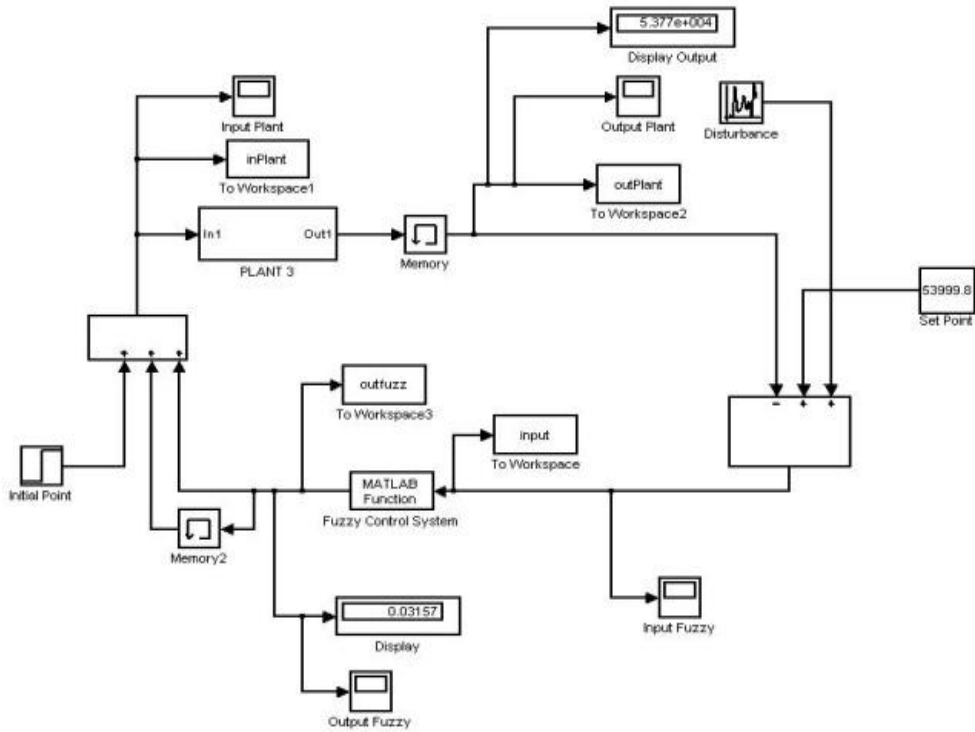

Figure 3 Fuzzy control system simulation design

Figure 3 shows the simulation design for the fuzzy control system. The basic concept of this simulation was to keep the  $N_1$  RPM stabilize at around 53339.8(set point). To describe the system in general, the user defined input, which was in the form  $N_1$  RPM, would enter the Fuzzy Control System. The output of the Fuzzy Control System, which would be in the form of Fuel flow, would enter the simulated plant. The outcome from the simulated plant would be routed back into the input port and serve as a feedback error signal.

#### 4 Result and Analysis

To test the reliability of this control system, a set of disturbances was given periodically and continuously. For the first session, the disturbance was given periodically. The sample time in use was 1000s. Figure shows the control system's response if it was given disturbance of -100-100  $N_1$  RPM with a sample time of 1000.  $N_1$  RPM will stabilize around 54250 at  $t=560$  s. The fuel flow also showed similar response. It stabilized on approximately 1.95 at  $t=527$  s. The control system was able to maintain its stability and only showed very small oscillation in a short brief period every time the disturbance occurs.

The stable time for each disturbance stayed at around  $400s < t < 500s$ . But as the disturbances grew larger, the oscillation grew increasingly larger. The occurrence of these oscillations also became more often and lasted longer, but the system always managed to stabilize afterwards. See Figure 5 for the chart of fuel flow using 1000s as sample time and increasing disturbance.

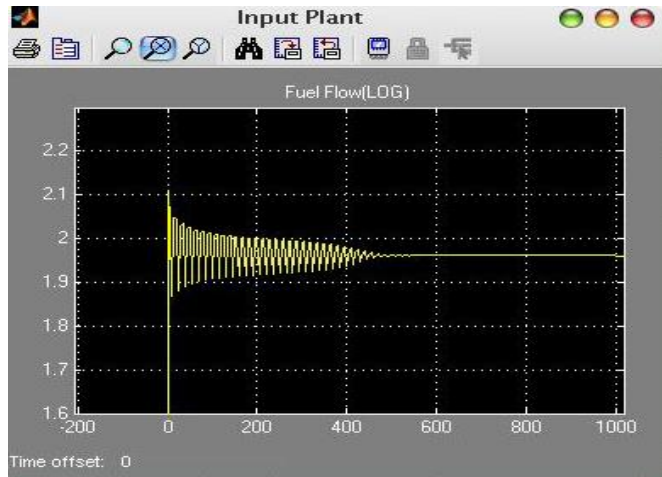

(a)

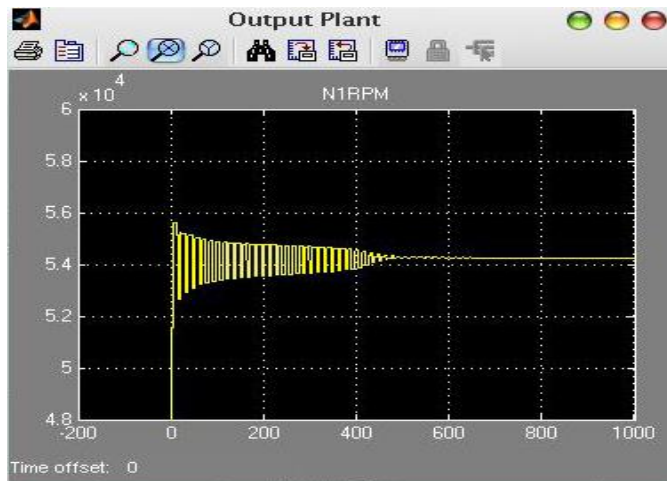

(b)

**Figure 4 Simulation result : (a) fuel flow simulation (b) N1 RPM simulation**

For the second session, the disturbance was given continuously, and we increase the disturbance size to test the system. On Figure 6 (a) and 6 (b), the system was given disturbance in the range of -50 to 50  $N_1$  RPM with a continuous sample time. The control system will maintain its stability around these points until the disturbance reached around -125 to 125 RPM. During this condition, the oscillation was increasingly larger and the control system was starting to have difficulties maintaining stability. The  $N_1$  RPM would seem to stabilize at  $t=500s$ , but as the simulation goes on, it will suffer further disturbance starting since  $t=800s$ . The amplitude of the oscillation varied around 53500-54500 RPM. The fuel flow also had the same behavior.

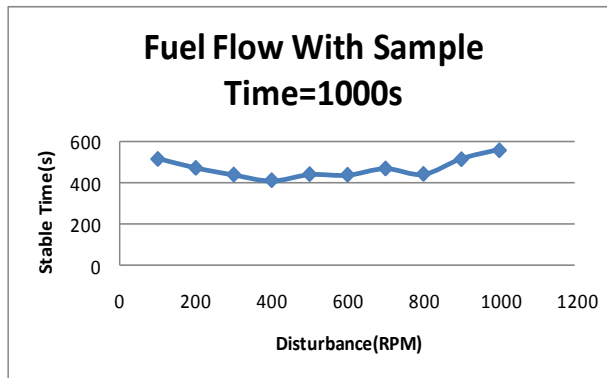
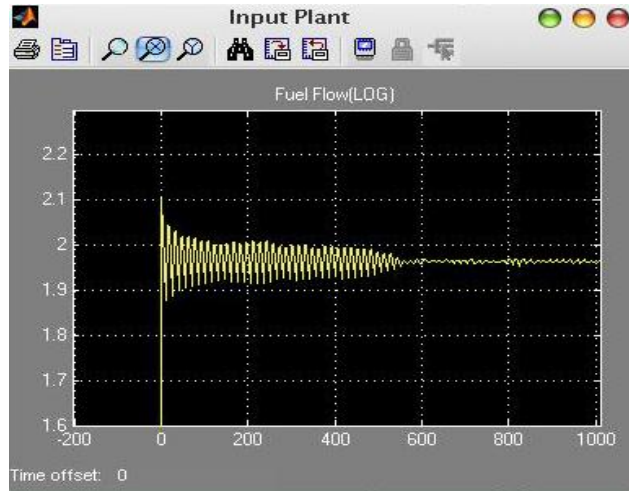
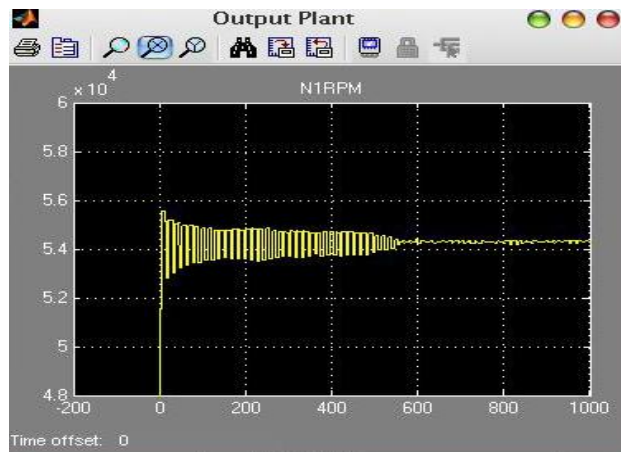

Figure 5 Fuel flow with sample time=1000s



(a)



(b)

**Figure 6 Simulation with disturbance : (a) fuel flow simulation (b) N1 RPM**

Figure 7 shows the fuel flow stable time condition respectively to disturbance. As it can be seen from the chart, the stable time when the disturbances were at the range of -25 to 25 and -75 to 75 remained stable around  $t = 550$  s. When the disturbances were raised up to -125 to 125, the stable time dropped to  $t = 510$  s. But even though the stable time became faster, the oscillation that occurs grew increasingly large.

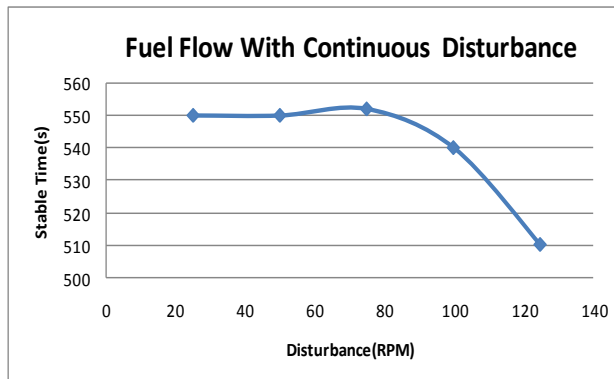

Figure 7 Fuel flow with continuous disturbance

## 5 Conclusion

Based on the result and analysis it can be concluded:

1. Fuzzy Control System may be applied in the aircraft fuel control system. The system was able to stabilize both the  $N_1$  RPM and the Fuel Flow in a considerably short period of time. (approximately  $t = 500$  s)
2. The system was also able to withstand disturbances, whether it came periodically or continuously. For periodic disturbances with 1000 s as the sample time, the control system was able to maintain its stability with disturbances up to -1000 to 1000 RPM.
3. As for continuous disturbance, the system was able to withstand disturbances up to -150 to 150 RPM. This is considered stable enough since continuous disturbances are not likely to occur in a large scale.

## 6 References

- [1] M.Schleicher, F.Blasinger. *Control Engineering-A Guide For Beginners*. JUMO GmbH&CO.KG. 2003.
- [2] T.Cuatto, C.Passerone, L.Lavagno, A.Jurecska, A.Damiano, C.Sansoe, A.Sangiovanni-Vincentelli. *A Case Study In Embedded System Design : an Engine Control Unit*.
- [3] A.Balluchi, M.D Di Benedetto, A.Ferrari, G. Gaviani, G.Girasole, C.Grossi, W.Nesci, M.Pennese, A.L Sangiovanni-Vincentelli. *Design Of A Motorcycle Engine Control Unit Using An Integrated Control-Implementation Approach*. 2003.
- [4] Toyota Motor Sales, USA. TOYOTA
- [5] Treager, I.E, *Aircraft Gas Turbine Engine Technology*, McGraw-Hill,1979.
- [6] The Allison Bendix 250 Technical Manuals. ALLISON
- [7] F.M McNeill, E.Thro. *FUZZY LOGIC-A Practical Approach*. AP Professional. 1994
- [8] K.M Passino, S.Yurkovich. *FUZZY CONTROL*. Addison-Wesley. 1998.
- [9] A.J. Chipperfield, B Bica, P.J. Fleming. *Fuzzy Scheduling Control of a Gas Turbine Aero-Engine: A Multiobjective Approach* IEEE TRANSACTIONS ON INDUSTRIAL ELECTRONICS, VOL. 49, NO. 3, JUNE 2002.
- [10] [www.mathworks.com/access/helpdesk/help/toolbox/fuzzy/fp351dup8.html](http://www.mathworks.com/access/helpdesk/help/toolbox/fuzzy/fp351dup8.html)