

Biological Systematics of the Genus *Ceratina*, Subgenus *Ceratinidia*
(Hymenoptera, Apoidea, Apidae)

By

Natapot Warrit

B.S., Chulalongkorn University, 2000

M.A., University of Kansas, 2002

Submitted to the Department of Ecology and Evolutionary Biology
and the Graduate School of the University of Kansas
In partial fulfillment of the requirements for the degree of
Doctor of Philosophy

Dr. Deborah R. Smith
Chairperson

Dr. Charles D. Michener
Co-chair

Committee members

Dr. Robert H. Hagen

Dr. Daphne G. Fautin

Dr. Matthew J. Buechner

Date defended: _____

The Dissertation Committee for Natapot Warrit certifies
that this is the approved version of the following dissertation:

Biological Systematics of the Genus *Ceratina*, Subgenus *Ceratinidia*
(Hymenoptera, Apoidea, Apidae)

Committee:

Dr. Deborah R. Smith
Chairperson

Dr. Charles D. Michener
Co-chair

Dr. Robert H. Hagen

Dr. Daphne G. Fautin

Dr. Matthew J. Buechner

Date approved: _____

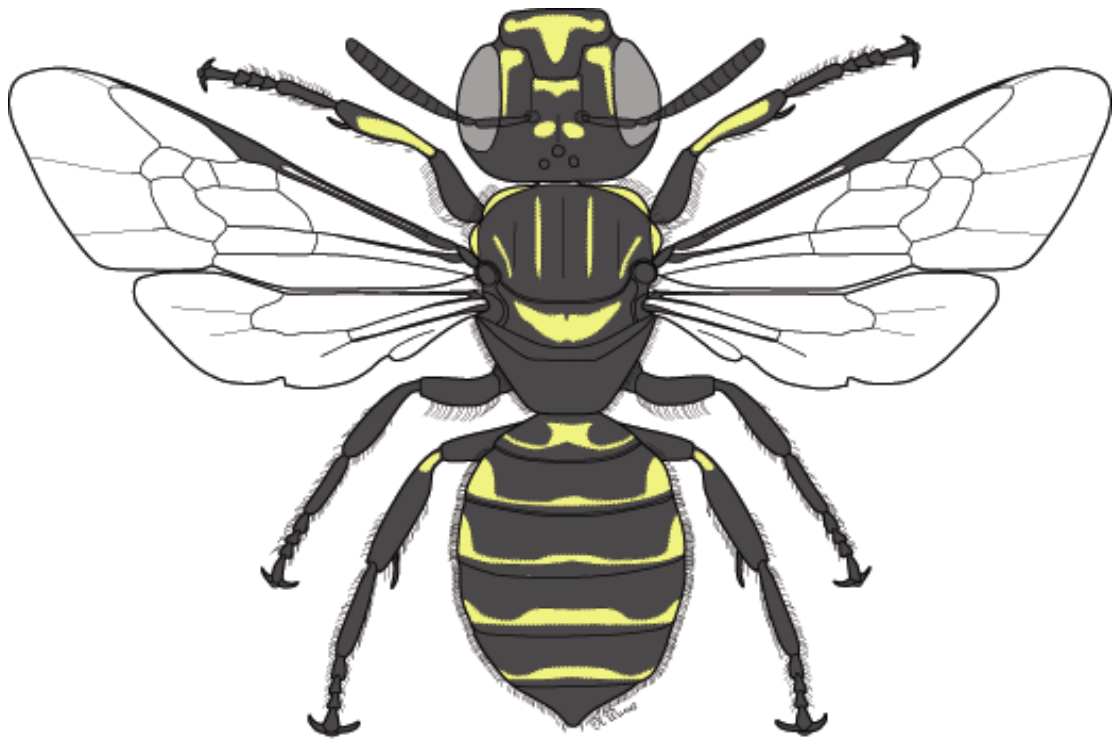

Ceratina lepida Smith

*I dedicate this work to my parents,
Dr. & Mrs. Bantoone and Panchit Warrit,
For their love, support, and understanding*

ABSTRACT

The Oriental species of the genus *Ceratina*, subgenus *Ceratinidia* are revised, based on a study of approximately 3,100 specimens. Thirty-seven species are recognized, with three described as new. All species are fully described and diagnosed, except for *C. incertula* and *C. maai*. Identification keys for both sexes are provided. The new species are *C. Chiangmaiensis*, *C. Malukuensis*, and *C. rugosoclypeata*. *Ceratina alpicola* Shiokawa and *C. taiwanensis* Shiokawa are elevated from subspecies status, and *C. incertula* and *C. lepida* var. *sutepensis* Cockerell are elevated from junior synonymy. The following names are relegated to synonymy: *C. alexandrae* Baker under *C. carinifrons* Baker, *C. bowringi* Baker under *C. hieroglyphica* Smith, and *C. lepida* var. *sublepida* Cockerell under *C. sutepensis*. Lectotypes are designated for *C. bicuneata* Cockerell, *C. cognata* Cockerell, *C. selangorensis* Cockerell, *C. compacta* Smith, *C. flavipes* Smith, *C. hieratica* Baker, *C. interrupta* Alfken, *C. rugifrons* Smith, *C. simillima* Smith, *C. lepida* var. *sutepensis* Cockerell, *C. lepida* var. *sublepida* Cockerell.

In addition, a specific-level cladistic analysis of *Ceratinidia* species is presented. One hundred and twenty characters of adult external morphology are identified and coded for 31 species, along with 5 outgroup taxa. The resulting topology (from the use of 84 out of 120 characters) is used in the formation of a species-group classification of the subgenus. Five species-groups are recognized: *tropica*, *bryanti*, *flavipes*, *accusator*, and *compacta*. Two *Ceratina* subgenera previously not included in *Ceratinidia*, *Lioceratina* and *Xanthoceratina*, are placed

under the accusator species-group, but the species formerly placed in these subgenera are not treated in detail. The geographical distribution and dispersal of *Ceratinidia* species are discussed herein.

ACKNOWLEDGMENTS

This project was suggested, guided, and improved by Dr. Charles D. Michener. I am forever grateful to his mentorship through good and difficult circumstances during my graduate school years. I also thank Dr. Deborah R. Smith for her support and encouragement. I have learned many valuable examples to be a good teacher, a mentor, a scientist, and a person from these two role models.

I would like to thank Daniel J. Bennett, Victor H. Gonzalez, Dr. Charles D. Michener, Molly G. Rightmyer, and Dr. Deborah R. Smith for their advice and long discussions that have greatly improved this work. Photographs of the bees presented herein were partly taken by Daniel J. Bennett and Molly G. Rightmyer. I thank Dr. Mathew L. Buffington at the Smithsonian Institution for allowing me to use the Entovision Photographic Systems, and Molly G. Rightmyer for arranging the meeting. I thank Drs. Charles D. Michener and Zachary H. Falin for facilitating loans from many institutions. Dr. Charles D. Michener has taken the extra tasks of borrowing almost every known *Ceratinidia* type from all over the world to help with this study. I thank Dr. Michael S. Engel for providing specimens from Dr. Donald B. Baker's collection. I thank Mr. George R. Else from the Natural History Museum (British Museum) for giving access to type materials during my visit to London in 2004. In addition, Dr. David G. Furth has given me many welcomed opportunities to examine the collection at the Smithsonian Institution and I am grateful for his hospitality. I especially thank Mr. Makoto Shiokawa for sending his own private collection to be examined and for our long distance communications.

I am greatly indebted to each of the individuals who loaned specimens used in this study; Dr. Cornelius van Achterberg (Nationaal Natuurhistorisch Museum, Leiden, The Netherlands), Mr. George R. Else (The Natural History Museum, London, United Kingdom), Drs. Michael S. Engle, Zachary H. Falin, and Charles D. Michener (University of Kansas Natural History Museum and Biodiversity Research Center, Lawrence, Kansas), Dr. David G. Furth and Ms. Maureen Melo (United States National Museum of Natural History, The Smithsonian Institution, Washington, D.C.), Mr. Tino Gonsalves and Dr. G. Allan Samuelson (Bishop Museum, Honolulu, Hawaii), Dr. Frank Koch (Museum für Naturkunde der Humboldt-Universität, Berlin, Germany), Dr. S. Lee (Seoul National University, Seoul, South Korea), Associate Professor Chariya Lekprayoon (Natural History Museum of Chulalongkorn University, Bangkok, Thailand), Dr. Wojciech J. Pulawski (California Academy of Sciences, San Francisco, California), Drs. Jerome G. Rozen Jr. and John S. Ascher (American Museum of Natural History, New York City, New York), Mr. Roy R. Snelling (Los Angeles County Museum of Natural History, Los Angeles, California), Mr. Masato Shiokawa (Hokkaido, Japan), Mr. Prachaval Sukamolnun (Chiang Mai University Entomological Collection, Chiang Mai, Thailand), Drs. Masaaki Suwa and Yoshizawa Kazunori (Hokkaido University, Sapporo, Japan), Dr. Osamu Tadauchi (Kyushu University, Fukuoka, Japan), Dr. Wu Yan-ru (Academia Sinica, Beijing, China), and Dr. Christopher O'Toole (Hope Entomological Collection, Oxford, United Kingdom).

I would like to thank the people and organizations for helping to fund my research: Drs. David E. Alexander, Bruce Cutler, and Orley R. Taylor Jr. (Entomology Endowment Fund, University of Kansas), Associate Professor Chariya Lekprayoon and Dr. Wisut Baimai (Biodiversity Research and Training Program, Thailand), the Entomology Program and the Department of Ecology and Evolutionary Biology of the University of Kansas, the University of Kansas Graduate School, and finally Dr. Bantoone and Mrs. Panchit Warrit, and Mrs. Boonsri Hongsyok.

I thank the members of my advising committee Drs. Robert Hagen, Daphne G. Fautin and Matthew J. Buechner for being on the committee and for their suggestions on this work. Drs. Daphne G. Fautin and Linda Trueb have greatly influenced and improved the author's scientific writing and communication skills. Finally, for friendship and moral support, I especially thank Drs. Charles D. Michener and Deborah R. Smith, Molly G. Rightmyer, Sarawut Peungrasamee, Daniel J. Bennett, Naruporn Saowanit, Tipwan Suppasat, Lynn S. Villafuerte, Victor H. Gonzalez, David S. McLeod, and Gordon Johnston.

TABLE OF CONTENTS

| | Page |
|--|------|
| Frontispiece..... | 3 |
| Dedication page..... | 4 |
| Abstract..... | 5 |
| Acknowledgements..... | 7 |
| Table of contents..... | 10 |
| Chapter 1 Introduction | |
| - General..... | 14 |
| - Historical Reviews..... | 16 |
| - Nesting and Social Biology..... | 18 |
| - Parasites..... | 21 |
| - Pollination..... | 21 |
| Chapter 2 Taxonomy of <i>Ceratinidia</i> | |
| - Introduction..... | 24 |
| - Materials and Methods..... | 25 |
| - Name-Bearing Types..... | 27 |
| - Species and Subspecies Recognitions..... | 29 |
| - General Morphology..... | 31 |
| - Species Descriptions, Keys, Synonyms, and Geographical Distributions..... | 46 |
| - Key to Species of Female <i>Ceratinidia</i> | 48 |
| - Key to Species of Male <i>Ceratinidia</i> | 57 |
| <i>Ceratina accusator</i> Cockerell..... | 64 |
| <i>Ceratina alpicola</i> Shiokawa new status | 71 |
| <i>Ceratina bicuneata</i> Cockerell..... | 76 |
| <i>Ceratina bryanti</i> Cockerell..... | 79 |
| <i>Ceratina carinifrons</i> Baker..... | 85 |
| <i>Ceratina Chiangmaiensis</i> Warrit and Lekprayoon new species | 93 |
| <i>Ceratina cognata</i> Smith..... | 96 |
| <i>Ceratina collusor</i> Cockerell..... | 104 |
| <i>Ceratina compacta</i> Smith..... | 110 |
| <i>Ceratina coptica</i> Baker..... | 118 |

| | |
|---|-----|
| <i>Ceratina demotica</i> Baker..... | 122 |
| <i>Ceratina flavipes</i> Smith..... | 125 |
| <i>Ceratina hieratica</i> Baker..... | 131 |
| <i>Ceratina hieroglyphica</i> Smith..... | 136 |
| <i>Ceratina incertula</i> Cockerell Incertae Sedis | 143 |
| <i>Ceratina interrupta</i> Alfken..... | 145 |
| <i>Ceratina jacobsoni</i> van der Vecht..... | 151 |
| <i>Ceratina japonica</i> Cockerell..... | 154 |
| <i>Ceratina jejuensis</i> S. Lee..... | 162 |
| <i>Ceratina lepida</i> Smith..... | 166 |
| <i>Ceratina lieftincki</i> van der Vecht..... | 172 |
| <i>Ceratina litoraria</i> van der Vecht..... | 179 |
| <i>Ceratina maai</i> Shiokawa and Hirashima Incertae Sedis | 185 |
| <i>Ceratina malukuensis</i> Warrit new species | 185 |
| <i>Ceratina moderata</i> Cameron..... | 190 |
| <i>Ceratina nigrolateralis</i> Cockerell..... | 197 |
| <i>Ceratina okinawana</i> Matsumura and Uchida..... | 206 |
| <i>Ceratina papuana</i> van der Vecht..... | 214 |
| <i>Ceratina pulchripes</i> Shiokawa..... | 219 |
| <i>Ceratina punctigena</i> van der Vecht..... | 223 |
| <i>Ceratina rugifrons</i> Smith..... | 228 |
| <i>Ceratina rugosaclypeata</i> Warrit new species | 233 |
| <i>Ceratina simillima</i> Smith..... | 239 |
| <i>Ceratina sutepensis</i> Cockerell new status | 248 |
| <i>Ceratina taiwanensis</i> Shiokawa new status | 254 |
| <i>Ceratina takasagona</i> Shiokawa and Hirashima..... | 259 |
| <i>Ceratina tropica</i> Crawford..... | 264 |

Chapter 3 Cladistic Analyses of *Ceratinidia*

| | |
|---|-----|
| - Introduction..... | 273 |
| - Materials and Methods..... | 275 |
| - Results..... | 277 |
| - Discussions..... | 282 |
| Interpretation of the Phylogeny and the Monophyly of <i>Ceratinidia</i> | 282 |
| Character Evolution in Males Sixth Sternum and the Species-Groups of <i>Ceratinidia</i> | 287 |
| Geographical Distribution, Dispersal, and Area of Endemism of <i>Ceratinidia</i> | 289 |

Chapter 4 Conclusion.....296

Literature Cited.....298

Figures.....309

Appendices

- Appendix I: Characters used in cladistic analyses.....355
- Appendix II: Data matrix of morphological states.....362
- Appendix III: Geographical distribution of *Ceratinidia*.....364

CHAPTER 1 INTRODUCTION

GENERAL

The Apidae is one of the most diverse families of bees, containing more tribes than any other family. Members of the family Apidae are highly diverse and vary morphologically and biologically. It is recognized as a natural group (monophyletic taxon) based on numerous synapomorphic morphological characters (Roig-Alsina and Michener, 1993). The biology of Apidae is also highly variable: from solitary to highly eusocial with differentiated castes, from nest provisioners to social parasites and cleptoparasites, from mass provisioners to progressive provisioners of brood cells to forms that completely lack brood cells, from nest excavators in soil or in wood to forms that occupy preexisting cavities or construct nests in the open. The Apidae is divided into three subfamilies (Roig-Alsina and Michener, 1993). Many authors prefer to recognize the most diverse and largest subfamily, Apinae, to be a sister taxon to the Nomadinae (parasitic bees), and place the Xylocopinae (carpenter bees) as the basal group. Only the Xylocopinae, which is dealt with in this work, is recognized undoubtedly as a monophyletic group in spite of the wide differences in size and appearance.

The Xylocopinae constitutes an assemblage of bees that are extremely diverse in size and appearance, but united by series of common characters. Xylocopinae includes two superficially very different sorts of bees: species of the tribe Xylocopini are large to very large, robust euceriform to anthophoriform bees, whereas the other three tribes (Manueliini, Ceratinini, and Allodapini) consist of small, slender, andreniform to hylaeiform bees (Michener, 2000).

I focus here on one of the groups of Ceratinini. The objectives are to revise an understudied group, the small carpenter bee subgenus *Ceratinidia* (Genus *Ceratina*), which occupies a wide range in Asia, and to discover the relationships among the species of this subgenus.

The genus *Ceratina* (the only genus of the Tribe Ceratinini) consists of 23 subgenera and is found in all continents (Terzo, 2000). None of the subgenera occurs naturally in both Eastern and Western hemispheres. The Eastern hemisphere subgenera include *Catoceratina*, *Ceratina sensu stricto*, *Ceratinidia*, *Copoceratina*, *Ctenoceratina*, *Chloroceratina*, *Dalyatina*, *Euceratina*, *Hirashima*, *Labroceratina*, *Lioceratina*, *Malgatina*, *Megaceratina*, *Neoceratina*, *Pithitis*, *Protopithitis*, *Simioceratina*, *Xanthoceratina*, and *Yasumatina*; the Western hemisphere subgenera include *Calloceratina*, *Ceratinula*, *Crewella*, *Euceratina* (one species, the parthenogenetic *C. dallatorreana* Friese, is established in California, where it was introduced by commerce), *Rhysoceratina*, and *Zadontomerus*. Eight out of twenty three subgenera, including *Ceratinidia*, consist of Oriental species.

The subgenus *Ceratinidia* Cockerell and Porter, 1899, consists of small to medium sized black bees with yellow maculations, usually solitary, and stem nesting. Its range covers major parts of Asia—Afghanistan to Japan (west to east) and the Primorskyi region of Russia to Indonesia and Western New Guinea (north to south) (Figure 1). Habitats include cultivated areas where original vegetation has entirely disappeared, and often in the neighborhood of human dwellings in towns and villages, in addition to less disturbed areas. The most recent works on systematics of the

Oriental species of *Ceratina* was by J. van der Vecht (1952). In this work, 22 species of *Ceratinidia* were recognized. This number of species has increased as more new species were discovered. This thesis is an attempt to gather all of the information relating to *Ceratinidia* systematics, including new information obtained from long hours of specimen examination and review.

HISTORICAL REVIEW

History of the study of *Ceratinidia* began in 1854 when the British entomologist Fredrick Smith described some species of Oriental ceratinine bees in the catalogue of bees in the British Museum, London. Five species of hylaeiform black bees with yellow markings were described at that time. One of the species described as *Ceratina hieroglyphica* was chosen in 1899 by Cockerell and Porter to be the type species of the then new subgenus *Ceratinidia* of the genus *Ceratina*. Since then this type species has created confusion for many bee researchers who tried to identify Oriental *Ceratina* with black bodies and yellow maculations. The name *C. hieroglyphica* has been used and applied widely to black and yellow *Ceratina* specimens in many major bee collections around the world without correct taxonomic identification (personal observation). This is because older species descriptions, mostly by Cockerell, provided little information on structural components, but focused mainly on the yellow coloration, which is often unreliable and homoplasious.

In 1952, the first major revision of *Ceratinidia* was published by J. van der Vecht. He recognized 22 *Ceratinidia* species, with a bias towards the fauna of the

former Dutch East Indies (Indonesia) where he worked. Many structural characters (mostly punctation) were described and used in keys to species. Two species-groups were recognized by characters of the male seventh tergum and sixth sternum—the *bryanti* and *compacta* species-groups. A third species-group (the *flavipes* species-group) was proposed by Shiokawa and Hirashima (1982). New species have been described (not more than 10) in the past 54 years since van der Vecht's revision, from the Korean peninsula (Lee et al., 2005), Japan and Mainland China (Shiokawa, 1963; Shiokawa and Hirashima, 1982; Shiokawa, 2002), and Hong Kong, India, and Sulawesi (Baker, 2002a; 2002b).

Terzo (2000) proposed a phylogeny of *Ceratina* subgenera based on 51 morphological characters of males and females. The phylogeny showed all Oriental *Ceratina* subgenera, except *Pithitis*, to be in one monophyletic clade, and included one New World subgenus, *Ceratinula*, in the same clade. *Ceratinidia* was placed as sister taxon to *Xanthoceratina* and *Liocertina*. However, Terzo's analyses included only three species of *Ceratinidia* (*C. bryanti*, *C. nigrolateralis*, and *C. flavipes*), and the characters that supported monophyletic status for *Ceratinidia* are reversal (2 characters: decrease in the density of punctation on face and the absence of the supra-antennal furrow). A new phylogenetic analysis of the subgenus shows the paraphyly of *Ceratinidia*, and hence the union of *Xanthoceratina* and *Lioceratina* with *Ceratinidia* (see Chapter 3).

NESTING AND SOCIAL BIOLOGY

All carpenter bees, including *Ceratinidia*, nest in dead plant materials (hollow stems or galls or burrows made in pithy stems or in rotten or solid wood), except for *Xylocopa* (*Proxylocopa*), which nests in the ground. Brood cells in the nests are unlined or the secreted lining is weak and scarcely detectable. One tribe, Allodapini, does not make cells and most feed their young progressively. The other tribes provision each cell with a loaf-shaped, firm, dry pollen mass, on which a single egg is placed.

Carpenter bees, except Allodapini, are usually regarded as having solitary lifestyles. However, many species in the other Xylocopinae (excluding Manuelliini) have behaviors that might suggest a potential for social behavior. Below is a list of some characters of the small carpenter bees relating to multifemale nest-making and nest-tending, subsocial behavior, and prereproductive assemblages (modified from Michener, 1990):

- (1) Long life of the adults.
- (2) Adults of both sexes often live together before reproduction (prereproductive assemblages). For temperate species, this happens during the winter.
- (3) Mutual tolerance of individuals in the nest.
- (4) More than one female in a nest during the time larvae are produced and reared. Division of labor can occur. One female will become queen (egg-laying female) while other females become workers. Alternatively, the colony

might consist one active foraging female and one or more inactive individuals (no permanent caste difference).

(5) Trophallaxis among adults in of both prereproductive assemblages and during active brood rearing.

(6) Pollen and nectar are eaten by the same or other adult individuals of the assemblage or colony (and in Allodapini are stored in the nest).

In *Ceratina*, prereproductive assemblages can be formed before mating and dispersal. New nests are made in dead, dry, pithy stems. The nest consists of a simple burrow with transverse partition made of bits of pith, which create cells for rearing larvae. Until now, only two *Ceratinidia* species have been studied extensively for their social behaviors—*C. flavipes* and *C. japonica* (Sakagami and Maeta, 1984; 1985; 1987a; 1987b). Both species are from Japan and inhabit similar niches. Despite the close relationship between *C. flavipes* and *C. japonica* (see Chapter 3), the former rarely forms colonies in nature while the latter usually does.

Sakagami and Maeta (1987a) reported that after the prereproductive assemblages and dispersal periods, some females of *C. japonica* usually stay in the same nests, mostly two females. Two types of nest sharing were observed: (1) both bees were in their first reproductive season, which means they are probably sisters, and (2) the mother stays in a nest with her daughter. In about half the colonies (of each type), both bees are presumably able to reproduce since both have enlarged ovaries. In the other half of the colonies, one bee has enlarged ovaries while the other has slender ovaries (Sakagami and Maeta, 1985). This suggests division of labor and eusociality

(if the bees are of two generations) or semisociality (if the bees are of the same generation). Even in colonies that have both females with enlarged ovaries, the behaviors of the bees are not equivalent.

On the contrary, *C. flavipes* was rarely seen to form a colony in nature. This bee has prereproductive assemblages, as in *C. japonica*, but females do not usually stay together over the winter. Therefore, female bees are usually alone when nesting begins in the spring. Sakagami and Maeta (1987b) carried out experiments with both *C. japonica* and *C. flavipes*. They placed large numbers of the adult female bees in cages with few nest sites (pithy stems). Colonies were formed by *C. japonica* but at a lower rate than in natural habitats. For *C. flavipes*, colonies were sometimes also formed, sometimes eusocial, but the social organization was often unstable, without mutual tolerance (e.g., when passing in the burrows). It is remarkable that a caste system (which is weak and variable) can arise in this solitary species.

Such social behaviors in *Ceratinidia* and some other carpenter bees might have arisen in a common ancestor of the Xylocopinae. In the Apinae, while various forms are frequently communal, highly eusocial behavior arises only in two corbiculate tribes (Apini and Meliponini) and presumably arose independently from that of Xylocopinae. Tropical *Ceratinidia* species should be investigated as to their solitary or social behaviors since the only two studied species are temperate forms. Prereproductive assemblages and other behaviors in tropical *Ceratinidia* have not yet been documented, although groups of females in nests in Java and Thailand suggest such assemblage (C.D. Michener, personal communication).

PARASITES

Mites in the genus *Sennertia* (Family Chaetodactylidae; approximately 60 species described) are generally associated with the Xylocopinae (Fain, 1981; Eickwort, 1994). Lombert et al. (1987) suggested that *Sennertia* are cleptoparasites that feed on pollen provisions and kill the young bees in the cells (however, some authors recognized that the mites, perhaps other species, develop in the cells without killing the brood (Skaife, 1952; Watmough, 1974; O' Connor, 1988)). Recently *S. (Eosennertia) bifida* was described (Kurosa, 2003) from museum specimens of three *Ceratinidia* species from Japan—*C. japonica*, *C. flavipes*, and *C. okinawana*. The mites were found on various locations on the bee's body but not on the head or the terminal portion of the metasoma. During my examination of specimens, I have come across *Sennertia* mites on other *Ceratinidia* species.

POLLINATION

Most species of *Ceratina* have been recognized to be polylectic (taking pollen from various unrelated kinds of flowers). Their activities tend to benefit pollination of native plants in areas that the bees inhabit and presumably do the same for cultivated plants. A few examples of pollination by the ceratinine bees that increases the crop yields are documented by Daly et al. (1971) and Batra (1979).

What makes *Ceratina* a good choice for pollination in agriculture is their nests in dry stem and twigs that can be moved easily. Also they can apparently be domesticated easily. Sakagami and Maeta (1987a) conducted a study on two

Ceratinidia species (see Nesting and Social Biology) in an enclosure. They placed hollow pithy stems to serve as nests in a cage and liberated the bees to forage on flowers inside the cage. The bees had no difficulty surviving and thriving inside the enclosure. The use of flowers near nests by *Ceratina* has been reported by Terzo (1992).

CHAPTER 2 TAXONOMY OF *CERATINIDIA*

INTRODUCTION

The purpose of this chapter is to provide detailed descriptions and keys to females and males of species of *Ceratinidia*. In descriptions, unless otherwise noted, all listed localities are based on specimens personally examined.

Many *Ceratinidia* species names were proposed by T. D. A. Cockerell, whose species names have been largely synonymized by subsequent authors (e.g., van der Vecht, 1952). Cockerell also provided a number of keys to *Ceratinidia* species, but characters used were mostly maculation characters found to be unreliable to differentiate many species. Van der Vecht (1952) provided an admirable key that can be used to identify Southeast Asian *Ceratinidia* species accurately. However, van der Vecht's key was limited to species of that region and neglected the majority of species from eastern China and Japan. Other geographically limited *Ceratinidia* keys are those of Baker (2002a, India and Hong Kong; 2002b, Sulawesi-Indonesia); Lee et al. (2005, Korea); Shiokawa (1969, Japan; 1999, Ryukyu Islands; 2002, eastern China and Taiwan). The keys presented herein combine all recognized species of the subgenus except those formerly placed in *Xanthoceratina* and *Liocertina* (see Chapter 3). The confusion from the use of regional keys, and from species found in more than one area, is reduced. Novel characters, hitherto unused, are also introduced.

MATERIALS AND METHODS

A total of approximately 3,100 specimens used in this study were borrowed from the individuals and institutions listed below. The city where each institution and/or individual is located is used below to indicate where specimens are preserved. **BANGKOK**—Natural History Museum of Chulalongkorn University, Thailand (C. Lekpreyoon); **BEIJING**—Academia Sinica (Chinese Academy of Sciences; Y. Wu); **BERLIN**—Museum für Naturkunde der Humboldt-Universität (F. Koch); **CHIANG MAI**—Chiang Mai University Entomological Collection, Department of Agriculture, Thailand (P. Sukamolanun); **FUKUOKA**—Kyushu University, Japan (O. Tadauchi); **SAPPORO**—Hokkaido University, Japan (M. Suwa and Y. Kazunori); **SAPPORO-SHIOKAWA**—Mr. Masato Shiokawa, personal collection, Japan; **HONOLULU**—Bishop Museum (T. Gonsalves and A. Samuelson); **LAWRENCE**—University of Kansas Natural History Museum and Biodiversity Research Center (C. Michener, M. Engel, and Z. Falin); **LAWRENCE-BAKER**—Donald and Madge Baker Collection, at the University of Kansas Natural History Museum and Biodiversity Research Center; **LEIDEN**—Nationaal Natuurhistorisch Museum, The Netherlands (C. Achterberg); **LONDON**—The Natural History Museum, U.K. (G. Else); **LOS ANGELES**—Los Angeles County Museum of Natural History (R. Snelling); **NEW YORK**—American Museum of Natural History (J. Rozen and J. Ascher); **OXFORD**—Hope Entomological Collections, Oxford University, U.K. (C. O’Toole); **SAN FRANCISCO**—California Academy of Sciences (W. Pulawski); **SEOUL**—Seoul National University, South

Korea (S. Lee); **WASHINGTON, D. C.**—United States National Museum of Natural History, The Smithsonian Institution (D. Furth and M. Melo)

Specimens were examined and measured via an Olympus SZ60 dissecting microscope and ocular micrometer or calipers. Photomicrographs were taken using Entovision Photographic System and MicroOptics Digital Image Systems.

Illustrations were prepared using Adobe Photoshop 7.0 and Adobe Illustrator 10.0.

Dissected male terminalia (sixth sternum, seventh tergum, and genitalic structures) were cleared using ca. 3M Potassium hydroxide (KOH) in water at room temperature and stored in glycerin in microvials on pins with dry specimens. Label data for all specimens were completely recorded. Label data for primary type material and paratypes are presented exactly as given.

NAME-BEARING TYPES

I have tried to examine the name-bearing type for all names and have indicated for each name whether I have seen its type, and in what collection the type is to be found. When I have not been able to examine a name-bearing type, I indicate the basis for my recognition of the name—examination of a paratype, specimens identified by the author of the name, or merely the printed information. For most recently named taxa, the name-bearing type was designated in print with the original description, and the specimen is labeled as the holotype. If an older author stated with his description that he had only a single specimen, I regard it as the holotype, even if it is only labeled “Type”.

Some older authors' however, such as F. Smith (1854, 1879), often did not say on how many specimens they based a description. Commonly one specimen is found, labeled as the TYPE. In such cases I designate that specimen as the lectotype even though the designation by labeling has not been published. I do this in accordance with ICZN, fourth edition, Article 74.5 and should additional specimens be found later in the same or another collection, none of them would be eligible for lectotype designation. Thus the usage of the name would not be subject to possible instability.

Because of earlier action by other authors, I accept one exception to these principles. *Ceratina hieroglyphica* Smith was based on specimens of three species, perhaps only three individuals. One, labeled "N Ind" was labeled as the TYPE in the Natural History Museum, London, but not published as such. Van der Vecht (1952),

not finding this specimen, designated the specimen from Hong Kong as the lectotype and published this designation. The latter is obviously the first published lectotype designation and therefore stands, even though Baker (2002a) tried to negate it.

The works of T. D. A. Cockerell present special problems for type understanding. Except perhaps in his very early (before 1900) works, Cockerell labeled for each new species one specimen as TYPE, the others if any in the type series as COTYPES [based on information from C. D. Michener, who spent a summer in Cockerell's laboratory in 1935]. Thus a TYPE for Cockerell was the holotype while COTYPE for Cockerell was PARATYPE, in current terminology. I have respected these usages, considering his TYPE as Holotype, as indicated by ICZN, fourth edition, Article 74.5. Except in cases where the type has been lost, I would not designate one of the cotypes as a lectotype.

In addition, Van der Vecht (1952) used the word "TYPE" for his holotype designation through out his descriptions, while designating additional material as paratypes. I have followed this treatment and recognized van der Vecht's "TYPE" as holotype.

SPECIES AND SUBSPECIES RECOGNITIONS

Species recognized herein are based on the typological, morphological, and biological (if applicable) species concepts. Closely related species are differentiated using (1) characters on the sixth sternum (S6) and/or seventh tergum (T7) of the males, for example, *C. japonica* and *C. flavipes* share many similar punctation patterns and maculations, but the submedian teeth on the subapical depression of S6 are vastly different; (2) maculation and other related information, for example, *C. bryanti* and *C. sutepensis* are similar to each other, but *C. sutepensis* has highly reduced maculation (in addition, *C. sutepensis* is found only in the mountainous area of Chiang Mai Province of Thailand, whereas *C. bryanti* is widespread in the Malay Peninsula and in Indonesia; no “hybrid” population is found between *C. sutepensis* and *C. bryanti* which suggests that *C. sutepensis* is not a part of the variations of *C. bryanti*); and (3) characters present in one species but not the other and consistent within the species, for example, *C. interrupta* has dense punctures on the gena, but the punctures are absent in the closely related species, *C. malukuensis* (also, *C. malukuensis* is found on islands where *C. interrupta* is absent).

Based on the three criteria mentioned above, however, it is sometimes difficult to make the decision about the species status objectively, because of the lack of needed information. I did not employ the term “subspecies” for two or more populations of the same species. This is because the term subspecies usually refers to populations of the same species that have some morphological differences, but can

still interbreed. None of the data gathered herein can answer whether the two populations can interbreed or not, although intergradation suggests interbreeding. For example, Shiokawa (1999) proposed a new subspecies of *C. okinawana* based mainly on the presence of the folded lateral arm of the hypostomal carina, and called it *C. o. sakishimensis*. I agree with Shiokawa's recognition of this population, but disagree with the usage of the term subspecies since none of the information provided by Shiokawa (and by myself) can show that *C. o. sakishimensis* is able to interbreed with *C. okinawana sensu stricto*. To avoid this kind of complication, I use the term "morph" for any groups of individuals of the same species that show character differences (most of the time the differences are not sharply discrete, but continuous), whether or not the morphs are allopatric or sympatric.

GENERAL MORPHOLOGY

Many general terms of the external morphological characters here used are based upon studies of the honeybee (*Apis mellifera*) by Snodgrass (1956) and other bees by Michener (1944; 2000). Taxon-specific terminology for *Ceratina* follows van der Vecht (1952), Daly (1973), and Terzo (2000).

Ceratina consists of slender (Hylaeiform or Andreniform), usually small, and shining bees. Hairs are inconspicuous. The scopa is reduced. The color varies from black to metallic green. Most species have yellow markings at least on the face, and some have extensive yellow maculation; e. g., the subgenus *Ceratinidia* (including the formerly recognized subgenera *Xanthoceratina* and *Lioceratina*). Some characters that unite *Ceratina* are: (1) the strongly concave lateral margin of the clypeus, the clypeus thus shaped like a thick, inverted T, (2) the mandibular shape, which is broad at the base and abruptly narrowed medially, (3) the lack of pygidial and prepygidial fimbriae and of the pygidial plate. The basal part of sternum 2 (S2) and often of S3 of females often has a semilunar area called the “wax plate.”

In *Ceratinidia*, yellow markings are present on all tagmata, which are otherwise black and often glossy (coloration on body parts will be discussed in detail later). Strong punctation, specifically on the frons, vertex, and mesepisternum, is an important character that separates *Ceratinidia* from species formerly segregated as the subgenera *Xanthoceratina* and *Lioceratina*. The male gonostylus is short with a comb of hairs. Body length varies from ca. 5.50 to 10.10 mm. Males are generally smaller than females, with more extensive yellow coloration.

To facilitate comparing characters among different species, I apply a numbering system in the descriptions. The numbers (1)–(43) are assigned to the structures used consistently throughout the description. For descriptions of species, two major groups of characters are used: (1) structure and punctuation and (2) maculation. To avoid redundancy in the descriptions, characters of the male that are similar to those of the female of the same species are omitted.

The terms for the different degrees of puncture size and density, exemplified on a hypothetical clypeus of *Ceratinidia*, are presented below (Figure 2). Illustrations of puncture size are displayed relative to one another and to the size of the clypeus.

Puncture Size

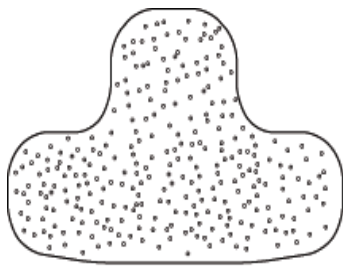

Small or Fine Punctures

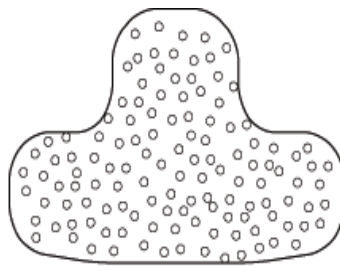

Medium-sized Punctures

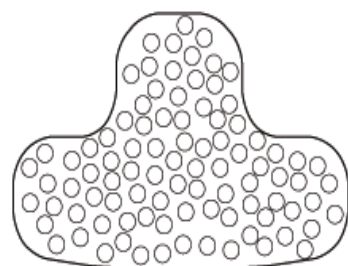

Large or Coarse Punctures

Puncture Pattern

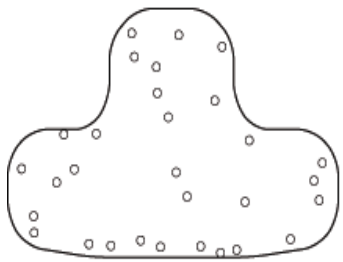

Few and Scattered Punctures
(puncture interspaces 4 or more times
broader than puncture diameters)

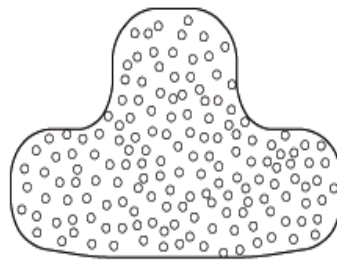

Sparsely Punctate
(puncture interspaces 2 or 3 times
broader than puncture diameters)

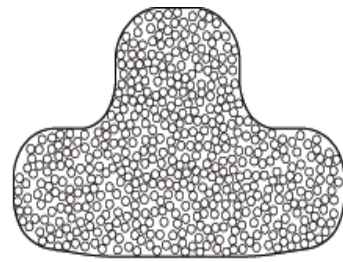

Densely Punctate
(puncture interspaces equal or
less than puncture diameters)

Figure 2. Degrees of puncture size and density on a hypothetical clypeus of *Ceratinidia*

Name and numbers of parts of each tagma (Prosoma-Mesosoma-Metasoma) and important appendages (legs and male genitalia) of a hypothetical *Ceratinidia* are listed below and the structures are illustrated (including information on area of punctation and yellow maculation, dotted).

Prosoma (= head, Figure 3)

Structure and Punctuation: frontal area, vertex, clypeus, labrum, paraocular area below antennal fossa, gena, lower part of supraclypeal area, area between compound eye and ocelli.

Maculation: frontal area, paraocular area below antennal fossa, clypeus, labrum, mandible, supra-clypeal area, base of scape, and gena. Length, shape, and size of the yellow maculae vary among species.

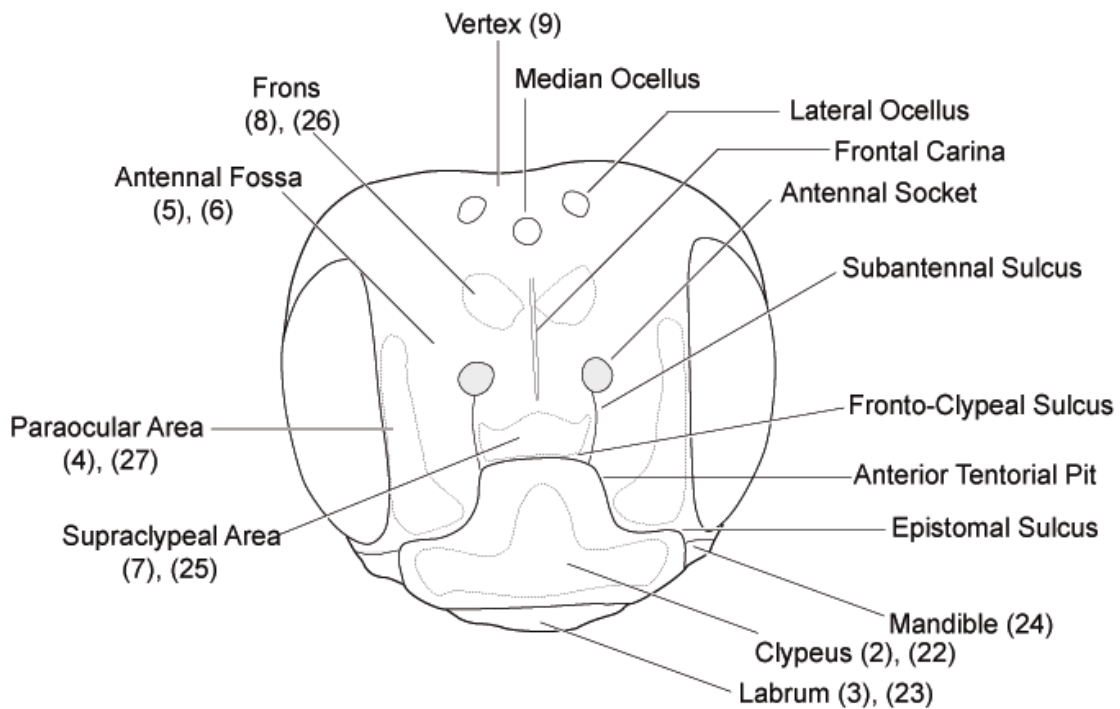
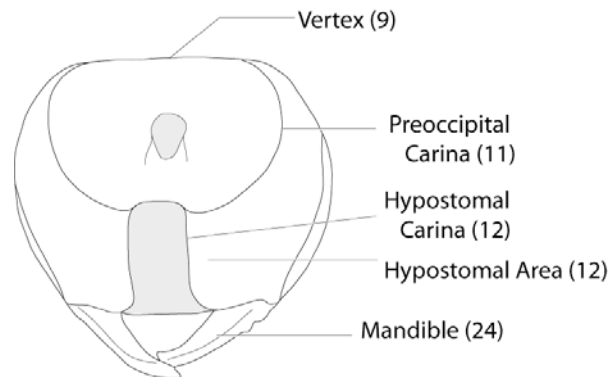
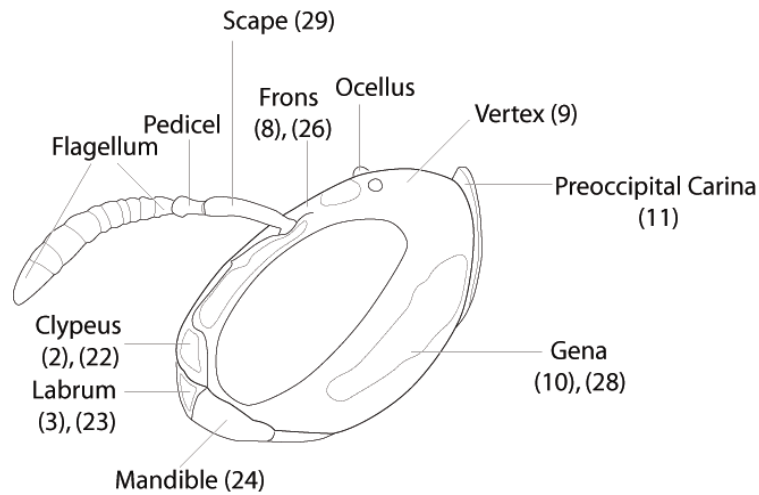

Figure 3. Facial structure of a hypothetical *Ceratinidia*: frontal view (above), lateral view (next page on the left), and posterior view (next page on the right). The numbers corresponding to the structures are discussed in the following paragraph.



Mesosoma (= thorax + propodeum or first abdominal segment, Figure 4)

Structure and Punctuation: pronotum, scutum, scutellum, mesepisternum, hypoepimeral area, scrobal area, propodeum, and leg segments (coxa, trochanter, femur, tibia, and tarsus).

Maculation: pronotum, pronotal lobe, area behind pronotal lobe on mesepisternum, scutum, scutellum, metanotum, and leg segments (coxa, trochanter, femur, tibia, tarsus, and basitarsus).

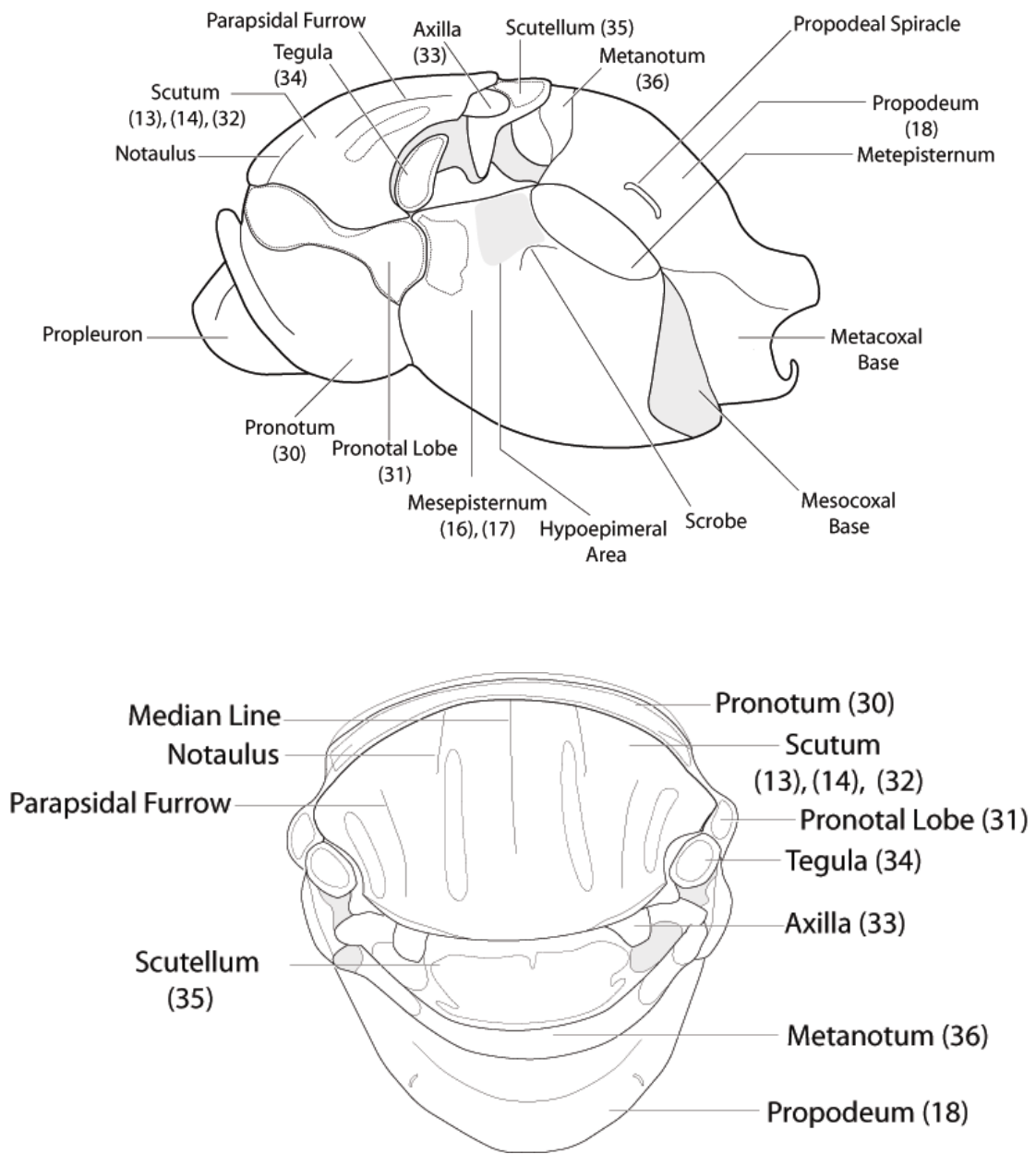
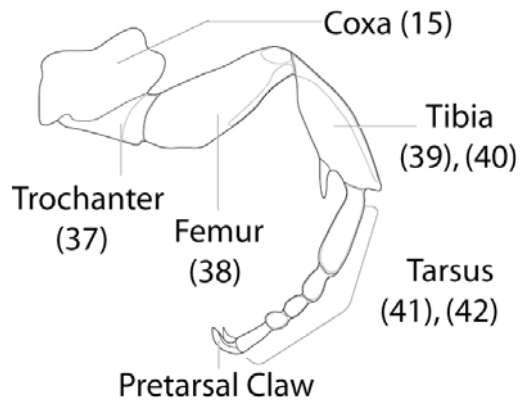

Figure 4. Mesosomal structure and appendage of a hypothetical *Ceratinidia*: lateral view (above), dorsal view (below), and leg (next page on the right). The numbers corresponding to the structures are discussed in the following paragraph.



Metasoma (= abdominal segments except the first, Figure 5, 6)

Structure and Punctuation: First tergum–sixth tergum (in female) and seventh tergum (in male), sixth sternum and genitalic structures in male.

Maculation: First tergum–sixth tergum (in female) and seventh tergum (in male).

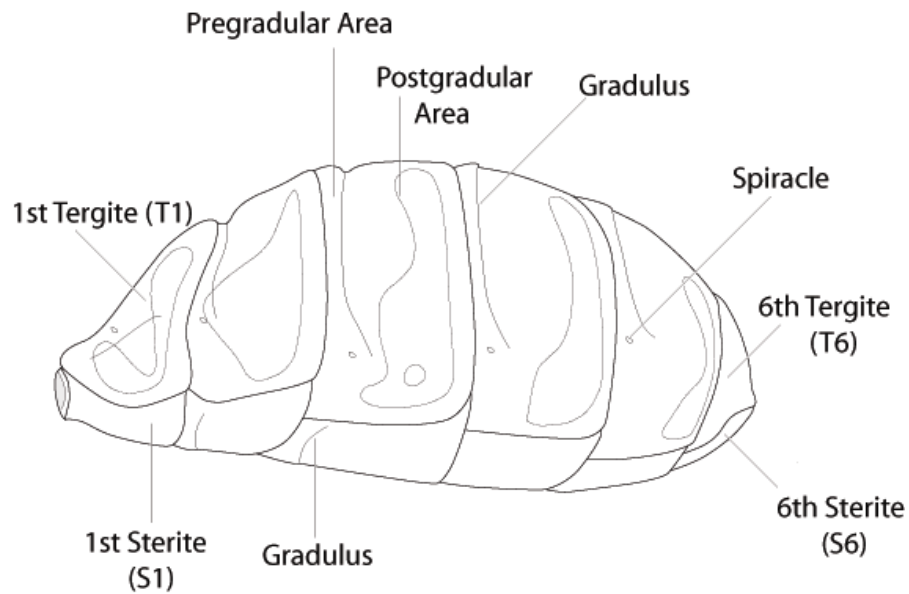

Figure 5. Lateral view of a metasoma of a hypothetical *Ceratinidia*

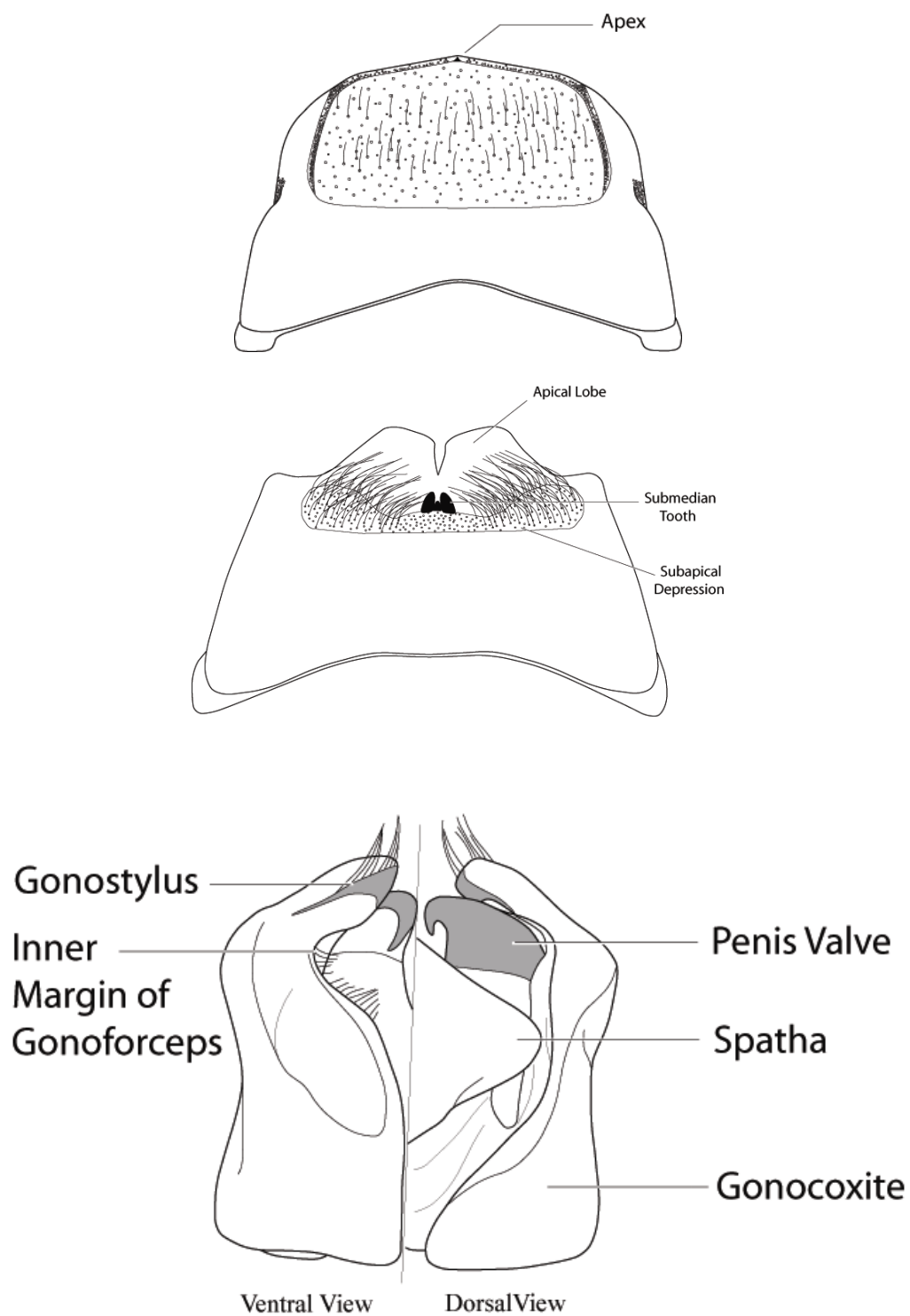

Figure 6. Seventh Tergum (top), sixth sternum (middle), and genitalia (bottom) of a hypothetical male *Ceratinidia*.

The following paragraphs are intended to introduce the characters used in this study. The studied characters are a combination of characters used by previous authors and new characters.

- (1) *Length*: This measurement was taken from the clypeus to the terminal segment of the metasoma (T6 in ♀ and T7 in ♂). The unit of measurement is millimeters (mm.)

STRUCTURE

- (2) *Clypeus*: The surface of the clypeus is one of the most important structures for the taxonomic and phylogenetic studies of *Ceratinidia*. Pattern and density of punctation vary across the species. A median longitudinal carina and longitudinal impressed area are also invaluable for accurate identification.
- (3) *Labrum*: The surface of the labrum does not vary greatly across species; however, within the same species, between sexes, the pattern and the density of punctation and bristles often vary.
- (4) *Paraocular area below antennal fossa*: The pattern and density of punctation on this structure is no less important to the study than the clypeus. One group of *Ceratinidia* species has a unique pattern of punctures clumped in the middle part of the paraocular area. Other species have uniformly dense small or large punctures across the paraocular area.
- (5), (6) *Antennal fossa*: The antennal fossa described herein is the concave area surrounding the antennal socket. The inner side of the antennal fossa near the frontal carina usually has dense punctures, though some species have scattered

punctures along the carina. The outer side of the antennal fossa is usually impunctate or with few small punctures, but an exception can be found (*C. moderata*). The dorsolateral area above the antennal fossa is usually flat and blends well with the adjacent structures (frons, compound eye, and vertex); but species from Sulawesi (*C. carinifrons* and *C. rugifrons*) and the Philippines (some specimens of *C. tropica*) exhibit an abruptly rising convexity between the compound eye and the area above the antennal fossa.

(7) *Supraclypeal area*: This term is used here for the lower, yellow part of the area. Usually, this area is impunctate or with a few small punctures.

(8), (9) *Frons and Vertex*: The pattern and density of punctures on the frons are highly varied across species, from sparsely and finely punctate to densely and coarsely punctate. The vertex is usually uniformly densely punctate. The area between the lateral ocellus and upper margin of the compound eye is usually with punctures less dense than on the frons and vertex.

(10) *Gena*: Usually the gena is impunctate, but some species have dense punctures.

(11) *Preoccipital carina*: A very obscure structure, sometimes difficult to locate if the vertex behind ocelli is curved downward. It is simpler to identify the carina if the vertex behind the ocelli is flat. And sometimes, as in Figure 4, it is strong, lamellate, and conspicuous.

- (12) *Hypostomal area and carina*: The pattern and density of punctation vary among species. The hypostomal carina is usually inconspicuous, but in species of the bryanti species-group, the carina is strongly noticeable.
- (13), (14) *Scutum*: The punctation on the anterior and posterior parts of the scutum is usually dense, but it can be sparse in some species. This is one of the most useful characters used to recognize different *Ceratinidia* species. Density of punctation on the lateral area of the scutum next to the outer side of the parapsidal furrow was first used by van der Vecht (1952) to efficiently differentiate major groups of females. The number of rows of punctures along the lateral margin of the scutum is positively related to the density of punctures on the lateral area.
- (15) *Procoxa*: The procoxa is usually rectangular or triangular with a round angle on the outer side at the base. Only *C. nigrolateralis* and some *C. collusor* specimens have the procoxa with a protrusion on the outer side at the base.
- (16), (17) *Mesepisternum*: Typically, the lateral and ventral areas of the mesepisternum are densely punctate, and the punctation of the posterolateral area near the mesocoxal base is usually less dense, but the punctation can vary among species. The hypoepimeral area is the upper part of the mesepisternum, above the scrobe and scrobal groove. It is convex, often partly impunctate. The lower margin of the hypoepimeral area in front of the scrobe is indicated by the lower margin of the convexity, because the scrobal groove is essentially absent. The anterior margin of the hypoepimeral area is

even more evanescent for the episternal groove is absent; the approximate anterior limit is the edge of the hypoepimeral convexity. The upper limit of the hypoepimeral area is the long and deep subalar pit. In *C. japonica* and related species, the hypoepimeral area is largely impunctate, sometimes extending near the pronotal lobe. I treat the small impunctate area around scrobe (character (17)) as a different entity from the hypoepimeral area. The size of the impunctate area around the scrobe also varies.

(18) *Propodeum*: Usually, the base of the propodeal triangle is coriaceous-reticulate and smooth. The lateral area is usually densely and finely punctate.

(19) *Sixth Sternum (S6) of male*: Van der Vecht (1952) initially divided *Ceratinidia* into two species-groups: (1) the bryanti species-group, which has two submedian teeth (sometimes with a median projection) on the subapical depression and (2) the compacta species-group, in which the submedian teeth are replaced by a V-shaped ridge (sometimes with a small denticle on the lateral area of the ridge). Another species-group, the flavipes species-group [recognized later by Shiokawa (1969)] has long (more than 3 times longer than wide) and outwardly bent submedian teeth. Herein (Figure 139 to 164), I note and illustrate other kinds of projections on the subapical depression of S6. These are valuable characters for the identification and phylogenetic analysis of the group.

(20) *Seventh Tergum (T7) of male*: This structure is practical for both the identification of species and for phylogenetic analysis. The size and shape of

the apex and lateral area of T7 are hypervariable and some can be used independently for species identification.

(21) *Genitalic Structure of male*: The genitalia among *Ceratinidia* species are superficially alike. However, the bristles along the apical margin and the width of the gonostylus, and the shape of the inner margin of the gonocoxite provide useful taxonomic detail.

MACULATION (yellow except noted)

(22) *Clypeus*: This is a good character for identification. The marking on the clypeus can vary from a small transverse apical line without an upper lobe to a large area that fully occupies the entire clypeus. Different species usually exhibit constant unique patterns.

(23), (24) *Labrum and Mandible*: The marking on these two structures in females is usually absent. Males can exhibit markings on these areas to varying degrees.

(25), (26) *Supraclypeal and frontal spots*: The marking on the supraclypeal area is immediately above the epistomal sulcus and is usually constant in shape (mostly triangular). *Ceratina litoraria* has a unique convex trituberculate supraclypeal marking. Usually in males the markings are more reduced than in females. The frontal spot varies among species and male individuals usually have reduced spots.

- (27) *Paraocular area*: The marking on the paraocular area is another important identification character. The marking comes in different shapes and forms: linear, linear and bent inward at the lower margin (hook-like), or linear with a gradual increase in width as one travels down near the lower margin. Males usually have more elaborate clypeal and paraocular area markings than females.
- (28) *Gena*: The marking can vary from absent to a band reaching the length of the compound eye.
- (29) *Base and apex of antennal scape*: The marking is usually absent, but when present, often yellow on base, it can be used effectively to identify species (e.g., *C. compacta* or *C. collusor*).
- (30) *Pronotum*: The transverse marking varies among species: fully developed, interrupted medially, reduced to only a lateral marking, or absent. The marking on the pronotal lobe is usually present. The transverse marking on the pronotum is sometimes connected to that of the pronotal lobe.
- (31) *Spot on mesepisternum behind pronotal lobe*: A hypervariable character that can differ among different populations of the same species.
- (32) *Scutum*: Longitudinal lines on the scutum, usually absent or present in numbers of four or two. This character is useful for species identification.
- (33), (34) *Axilla and Tegula*: Hypovariable characters, usually marking absent.
- (35) *Scutellum*: The marking is highly variable: rectangular, rectangular that is tapering posteriorly, triangular, two small spots, or absent.

- (36) *Metanotum*: Usually the marking is absent, but found in some species.
- (37) *Apices of protrochanter and mesotrochanter*: Either present or absent.
- (38) *Profemur*: The marking can be present on either the outer side or inner side at the apex of the femur, or on both sides. The inner spot usually extends basad to varying degree.
- (39) *Protibia and Mesotibia*: The markings on these two structures are usually similar to one another, and are usually found on the outer sides of the tibiae; the lengths of the markings vary.
- (40) *Metatibia*: Marking is not always in the same pattern as on the pro- and mesotibia, but located on the outer side of the hind tibia; length varies.
- (41) *Tarsi except Metabasitarsus*: Highly variable: from black to ferruginous to yellow.
- (42) *Metabasitarsus*: The marking is not always the same color as other tarsal segments, and for conveniences in description, it is treated separately.
- (43) *Metasoma*: The tergal bands can be highly variable among species. The T1 band can be completely developed, and enclosing two black spots, or absent. The T2 and T3 bands can be unbroken, broadly interrupted medially or absent. The female T6 and male T7 always lack markings.

SPECIES DESCRIPTIONS, KEYS, SYNONYMS, AND GEOGRAPHICAL
DISTRIBUTIONS

SYSTEMATICS

Genus *Ceratina* Latreille

Ceratina Latreille, 1802a: 432. Type species: *Apis cucurbitina* Rossi, 1792 = *Hylaeus albilabris* Fabricius, 1793, monobasic. Suppressed by Commission Opinion 1011 (1973).

Ceratina Latreille, 1802b: 380. Type species: *Apis cucurbitina* Rossi, 1792 = *Hylaeus albilabris* Fabricius, 1793, monobasic. Placed on Official List of Generic Names in Zoology by Commission Opinion 1011 (1973). [Later type designations were listed by Michener (1997).]

Subgenus *Ceratinidia* Cockerell and Porter

Ceratina (*Ceratinidia*) Cockerell and Porter, 1899: 406. Type Species: *Ceratina hieroglyphica* Smith, 1854

Ceratina (*Lioceratina*) van der Vecht, 1952: 32 **new synonym**

Ceratina (*Xanthoceratina*) van der Vecht, 1952: 39 **new synonym**

DIAGNOSIS.—*Ceratinidia* is the *Ceratina* subgenus with extensive yellow maculation on all tagmata. The often recognized two subgenera, *Lioceratina* and

Xanthoceratina, have relatively more extensive maculation on the clypeus, paraocular area, scutum, mesepisternum, scutellum, metanotum, and terga; and have more delicate, less dense punctation. They are shown below (see Chapter 3) to be included in *Ceratinidia*. Male *Ceratinidia* can be distinguished from other *Ceratina* subgenera by the presence of a tuft of long hairs, usually divided into two parts, on the apex of gonostylus of male genitalia [In species formerly placed in *Lioceratina*, the tuft of long hair on the apex of the gonostylus is absent].

KEY TO SPECIES OF FEMALES *CERATINIDIA*

- 1 Area above antennal fossa adjacent to compound eye margin conspicuously rising abruptly above level of eye, shiny, and usually, impunctate.....2
- 1 Area above antennal fossa adjacent to compound eye margin not rising above level of eye.....4
- 2(1) Supraclypeal area impunctate, transversely strigose or at most with 1–2 punctures; marking on paraocular area divided into upper, and lower spots.....*C. tropica* (part)
- 2 Supraclypeal area with fairly dense and coarse punctures; marking on paraocular area not divided, linear, lower part bent inward, and short.....3
- 3(2) Clypeus and paraocular area densely and coarsely punctate with well-defined punctures (Figure 36); punctures on anterior portion of scutum continuing along anteromedian line and parapsidal furrow as at least one single row to densely punctate posterior part.....*C. rugifrons*
- 3 Clypeus and paraocular area fairly densely punctate with shallow ill-defined punctures (punctures well separated by more than a puncture diameter) (Figure 11); scutum with no row of punctures along anteromedian line and parapsidal furrow, at most with few scattered punctures.....*C. carinifrons*
- 4(1) Upper lobe of inverted-T marking on clypeus with deep median incision (more than 1/3 of clypeal length), sometimes incision dividing marking into halves (Figures 21 and 27); marking on paraocular area and frontal spot linear.....5
- 4 Upper lobe of inverted-T marking on clypeus without deep median incision or with small median incision (not more than 1/3 of clypeal length); marking on paraocular area and frontal spot varied.....6

- 5(4) Gena with dense coarse punctures; hypostomal area densely punctate; scutum with row of punctures along anteromedian line and parapsidal furrow.....*C. interrupta*
- 5 Gena almost impunctate, sometimes with few scattered shallow punctures; hypostomal area with few shallow punctures; anteromedian line and parapsidal furrow without row of puncture laterally, at most with few scattered punctures.....*C. malukuensis*
- 6(4) Lateral area of scutum without punctures or at most with one incomplete row of punctures along outer side of parapsidal furrow; area between lateral margin of scutum and parapsidal furrow shiny impunctate or with few punctures.....7
- 6 Lateral area of scutum with one or usually two or more complete rows of punctures along outer side of parapsidal furrow; area between lateral margin of scutum and parapsidal furrow densely punctate or partially punctate.....33
- 7(6) Procoxa angularly produced on outer lateral side.....8
- 7 Outer lateral side of procoxa rounded, without prominent process.....9
- 8(7) Frontal area above frontal spot sparsely punctate, with no more than 15–20 punctures; area between compound eye and dorsolateral margin of antennal fossa shiny and impunctate (at most with 1 or 2 punctures); base of antennal scape often yellow or ferruginous, with abrupt color change, sometimes apex yellow; marking on paraocular area gradually widened from top to bottom (Figure 14); mesotibia dark brown to black with yellow line on outer side.....*C. collusor*
- 8 Frontal area above frontal spot densely punctate, punctures occupying almost entire area; area between compound eye and dorsolateral margin of antennal fossa varied (densely punctate, sparsely punctate, with few punctures, or impunctate); base of antennal scape ferruginous to black (except yellow in specimens from Palawan), apex black; marking on paraocular area varied

- (gradually widened from top to bottom or widened abruptly at median area from top to bottom) (Figure 30); marking on outer side of mesotibia varied (absent, small spot at base, or yellow line extending for entire tibia length).....*C. nigrolateralis*
- 9⁽⁷⁾ Punctures on mesepisternum remote, separated by 1–1.5 times puncture diameters, posterolateral area of mesepisternum near mesocoxal base with shiny area with few punctures (Figures 82, 87, 98); hypoepimeral area with large impunctate space above scrobe10
- 9 Punctures on mesepisternum dense, interspaces less than puncture diameter, posterolateral area of mesepisternum near mesocoxal base with slightly less dense punctures than lateral and ventral areas; hypoepimeral area with or without large impunctate area above scrobe.....12
- 10⁽⁹⁾ Dorsolateral area of outer side of antennal fossa with clump of medium-sized punctures, sometimes with many bristles.....11
- 10 Dorsolateral area of outer side of antennal fossa shiny and largely impunctate.....*C. Chiangmaiensis*
- 11⁽¹⁰⁾ Marking on paraocular area usually present only on lower part.....*C. moderata*
- 11 Marking on paraocular area well-developed, at least reaching level of antennal fossa*C. demotica*
- 12⁽⁹⁾ Two thirds to almost entire hypoepimeral area near wing base and above scrobe impunctate and hairless (Figures 78, 88, 89, 93, 94, 108).....13
- 12 Impunctate area above scrobe sometimes conspicuous but at most less than half of entire hypoepimeral area near wing base and above scrobe.....18
- 13⁽¹²⁾ Marking on clypeus with developed upper lobe (sizes varies), without median deep median incision on upper or lower or both sides (Figures 8, 18, 41); yellow transverse band on pronotum unbroken and connected to yellow spot on pronotal lobe; yellow spot behind pronotal lobe present; marking on scutellum rectangular, narrowed posteriorly; frontal spot large; scutum with four bright yellow longitudinal lines.....14

- 13 Marking on clypeus without upper lobe (sometimes transverse marking divided medially), or with poorly developed upper lobe with median incision on upper or lower or both sides (Figures 17, 23, 24); yellow transverse band on pronotum often interrupted medially (sometimes absent) and not connected to yellow spot on pronotal lobe (which is sometimes absent); yellow spot behind pronotal lobe absent; marking on scutellum small, triangular or reduced to one or two small spots or absent; frontal spot small oval or linear; scutum usually without longitudinal lines (if present, lines vague).....16
- 14⁽¹³⁾ Metatibia dark brown with yellow spot at base; tarsi dark brown.....*C. alpicola*
- 14 Outer side of metatibia at least half yellow; tarsi ferruginous to yellow (metatarsus yellow).....15
- 15⁽¹⁴⁾ Inner side of metatibia yellow.....*C. hieratica*
- 15 Inner side of metatibia half black half yellow.....*C. takasagona*
- 16⁽¹³⁾ Upper lobe of inverted-T marking on clypeus reaching at most half of clypeal length (sometimes with median incision on upper and/or lower margin, or median incision separating marking into halves) (Figure 23); mesotibia dark brown to black with or without yellow spot at base.....*C. japonica*
- 16 Upper lobe of inverted-T marking on clypeus absent, lateral arm of marking sometimes divided in half (some specimens without yellow marking on clypeus) (Figure 17); mesotibia dark brown with yellow spot at base usually extending for half of tibial length.....17
- 17⁽¹⁶⁾ Scutum usually dark without longitudinal lines; T1–T3 bands usually broadly interrupted medially.....*C. flavipes*
- 17 Scutum with four longitudinal lines; T1–T3 bands unbroken.....*C. jejuensis*
- 18⁽¹²⁾ Paraocular area with dense small to coarse punctures clumping together on median part, few punctures on lower part (Figure 10, 19, 31, 32, 39); clypeus with conspicuous median longitudinal impressed area, dorsal and dorsolateral area of clypeus with dense small to medium-sized punctures, median area

| | | |
|--------------------|---|-----------------------------------|
| | usually smooth and impunctate, but sometimes slightly rugose with few punctures..... | 19 |
| 18 | Paraocular area without clump of dense punctures on median part of paraocular area (pattern of puncture varies, but not as described as above)..... | 24 |
| 19 ⁽¹⁸⁾ | Scutum with four longitudinal lines; yellow transverse band on pronotum usually unbroken..... | 20 |
| 19 | Scutum without yellow longitudinal lines; yellow transverse band on pronotum often interrupted medially..... | 23 |
| 20 ⁽¹⁹⁾ | Anterior portion of scutum densely punctate (interspaces less than puncture diameter); profemur with yellow spot at apex (sometimes near apex on inner side); metatibia with yellow spot at base..... | 21 |
| 20 | Anterior portion of scutum sparsely punctate (interspaces broader than puncture diameter or more); profemur black, sometimes with vague yellow spot at apex; metatibia usually without yellow spot..... | <i>C. lepida</i> |
| 21 ⁽²⁰⁾ | Profemur without yellow spot on outer side at apex or at most with small vague spot, but with yellow spot near apex on inner side; Malay Peninsula and Indonesia..... | <i>C. bryanti</i> |
| 21 | Profemur with large yellow spot or band at apex on outer side, inner side spot absent or present; Ryukyu Island, Japan..... | 22 |
| 22 ⁽²¹⁾ | Lateral arm of hypostomal carina conspicuous apically; metasomal bands well-developed and unbroken; inner spot at apex of profemur absent or present..... | <i>C. okinawana sakishimensis</i> |
| 22 | Apex of hypostomal carina not conspicuous; T2 and T3 bands sometimes interrupted medially; inner spot at apex of profemur absent..... | <i>C. okinawana okinawana</i> |
| 23 ⁽¹⁹⁾ | Marking on scutellum more or less rectangular, narrowed posteriorly, or absent; Northern Thailand..... | <i>C. sutepensis</i> |
| 23 | Two small yellow spot on scutellum; Komodo Island..... | <i>C. litoraria</i> |

| | | |
|--------------------|---|--------------------------|
| 24 ⁽¹⁸⁾ | Clypeus strongly rugose or densely punctate, mostly on dark area; frons densely and coarsely punctate..... | 25 |
| 24 | Clypeus smooth, almost impunctate or with small fine punctures along dorsal and dorsolateral margin; frons with scattered punctures or at most small clump of punctures (more impunctate area than punctate area) [in <i>C. litoraria</i> with dense coarse punctures]..... | 27 |
| 25 ⁽²⁴⁾ | Paraocular area densely punctate throughout..... | 26 |
| 25 | Paraocular area smooth to slightly rugose with few small punctures mostly along compound eye margin..... | <i>C. rugosoclypeata</i> |
| 26 ⁽²⁵⁾ | Punctures on paraocular area coarse and large; lateral area of procoxa concavely depressed..... | <i>C. bicuneata</i> |
| 26 | Punctures on paraocular area small and fine; lateral area of procoxa not depressed..... | <i>C. litoraria</i> |
| 27 ⁽²⁴⁾ | Paraocular area with dense and well-defined punctures, interspaces between punctures less than puncture diameter..... | <i>C. litoraria</i> |
| 27 | Punctures on paraocular area variable; area smooth with few ill-defined punctures or with scattered punctures but interspaces between punctures broader than puncture diameter..... | 28 |
| 28 ⁽²⁷⁾ | Upper lobe of inverted-T marking on clypeus well-developed, at least reaching 2/3 of clypeal length to almost attaining frontoclypeal sulcus (apex more or less truncate), width of the lobe varies from 1/3 to 2/3 or more of the clypeal width..... | 29 |
| 28 | Upper lobe of inverted-T marking on clypeus small reaching at most half of clypeal length or absent (apex sometimes pointed)..... | 31 |
| 29 ⁽²⁸⁾ | Punctures on anterior portion of scutum remote, interspaces 2 times puncture diameter; yellow spot behind pronotal lobe present..... | <i>C. hieratica</i> |

- 29 Punctures on anterior portion of scutum dense, interspaces smaller than puncture diameter); yellow spot behind pronotal lobe usually absent or vague.....30
- 30⁽²⁹⁾ Base of antennal scape black; labrum black; upper lobe of clypeal marking at most 1/3 as wide as the clypeal width; India.....*C. coptica*
- 30 Base of antennal scape usually yellow; labrum often with yellow spot; upper lobe of clypeal marking 2/3 as wide as the clypeal width or more (Figure 14); Indochina, Malay Peninsula, and Indonesia.....*C. collusor*
- 31⁽²⁸⁾ T1 band usually reduced to small lateral spot or absent; T2 and T3 bands broadly interrupted medially, usually abruptly broadened laterally.....32
- 31 T1 band usually unbroken, sometimes almost enclosing two black spots; T2 and T3 bands usually unbroken (sometimes slightly interrupted medially).....*C. pulchripes*
- 32⁽³¹⁾ Marking on paraocular area linear, lower part bent inward (hook-like) or gradually widened from top to bottom; four longitudinal lines on scutum present; yellow transverse band on pronotum not interrupted medially; paraocular area smooth with shallow punctures along compound eye or with scattered ill-defined punctures; upper lobe of inverted-T marking of clypeus small and pointed, reaching at most half of clypeal length.....*C. accusator accusator*
- 32 Marking on paraocular area reduced, only lower portion of marking present, no upper part of marking near antennal fossa; yellow longitudinal lines on scutum absent (sometimes with vague outer lines); yellow transverse band on pronotum usually interrupted medially; paraocular area with scattered well-defined punctures; upper lobe of inverted-T marking small, sometimes absent, with median incision.....*C. accusator mutabilis*
- 33⁽⁶⁾ Upper lobe of inverted-T marking on clypeus small, sometimes absent, at most reaching half of clypeal length (Figure 26, 34, 38, 42).....34

- 33 Upper lobe of inverted-T marking on clypeus well-developed, reaching above half of clypeal length (apex truncate or triangular) (sometimes with small median incision).....37
- 34⁽³³⁾ Marking on paraocular area divided into two small spots, one on lower margin the other near antennal fossa, median longitudinal carina on clypeus usually conspicuous.....*C. tropica* (part)
- 34 Marking on paraocular area not divided in two small spots; median longitudinal carina on clypeus vague.....35
- 35⁽³⁴⁾ Clypeus usually densely punctate with small fine punctures mostly along dorsal and dorsolateral margin, less dense along median area; paraocular area densely punctate with small and fine punctures.....*C. litoraria*
- 35 Clypeus with scattered punctures throughout; paraocular area with scattered, not dense, middle-sized punctures.....36
- 36⁽³⁵⁾ Clypeus superficially rugose, usually with scattered small to middle-sized punctures on entire area or mostly on median and lower part; parapsidal furrow usually margined by two or more rows of punctures.....*C. simillima*
- 36 Clypeus smooth, sometimes shiny, almost impunctate with few small punctures along dorsal and dorsolateral margins; parapsidal furrow margined by at most one complete row of punctures.....*C. pulchripes*
- 37⁽³³⁾ Scutum with four longitudinal yellow lines; labrum with bright or vague yellow marking (absent in Thai specimens).....38
- 37 Scutum without longitudinal lines (Philippine specimens sometimes with two outer lines); labrum black without yellow spot.....39
- 38⁽³⁷⁾ Base of antennal scape yellow.....*C. compacta* (see also description of *C. incertula*)
- 38 Base of antennal scape black.....41
- 39⁽³⁷⁾ Clypeus smooth superficially, slightly rugose with shallow small punctures mostly on dorsal and dorsolateral area, median area almost impunctate;

- paraocular area smooth with few scattered small punctures mostly along compound eye; space between ocelli and upper part of compound eye impunctate or with few scattered punctures; gena shiny, almost impunctate, sometimes with few shallow punctures; posterolateral area near mesocoxal base of mesepisternum with punctures remote, unlike those on other areas of mesepisternum40
- 39 Clypeus with dense small punctures throughout (less dense in median area); paraocular area with dense small and medium-sized punctures; space between ocelli and upper part of compound eye with dense coarse punctures; gena densely punctate; mesepisternum densely and coarsely punctate throughout.....*C. punctigena*
- 40⁽³⁹⁾ Scutum black without longitudinal lines.....*C. cognata*
- 40 Scutum with two outer longitudinal lines.....*C. jacobsoni*
- 41⁽³⁸⁾ Paraocular area below antennal fossa with clump of dense small and medium-sized punctures, lower and upper parts with few punctures or impunctate; clypeus with dense punctures on dorsal and dorsolateral areas; median impressed area on clypeus conspicuous; marking behind pronotal lobe absent.....*C. taiwanensis*
- 41 Paraocular area below antennal fossa with scattered small to medium-sized punctures, mostly along compound eye margin, punctures not well-defined; clypeus superficially smooth with small punctures along upper clypeal margin, median impressed area on clypeus absent or vague; marking behind pronotal lobe present.....*C. lieftincki*

KEY TO SPECIES OF MALES *CERATINIDIA*

- 1 Subapical depression on S6 broadly bilobed medially with subequal lateral tooth (Figure 154); India.....*C. moderata*
- 1 Subapical depression on S6 without broad bilobed median projection.....2
- 2(1) Subapical depression on S6 with distinct median V-shaped ridge, often with small tooth on each side; small projection between teeth absent.....3
- 2 Subapical depression on S6 without median V-shaped ridge, with medium (2 times longer than wide) or long (more than 3 times longer than wide) submedian tooth, sometimes small projection present medially between the teeth.....10
- 3(2) Facial area (clypeus, paraocular area, frons, antennal fossa, and vertex) with dense and coarse punctures; dorsolateral area above antennal fossa adjacent to compound eye margin conspicuously rising abruptly above level of eye (partially or wholly densely punctate, Figure 192).....*C. rugifrons*
- 3 Facial area varied, not densely punctate with coarse punctures; dorsolateral area above antennal fossa adjacent to compound eye margin not rising above level of eye (punctures vary).....4
- 4(3) Lateral area of scutum without punctures or at most with punctures along anterior portion of parapsidal furrow; area between lateral margin of scutum and parapsidal furrow shiny impunctate or with few punctures.....5
- 4 Lateral area of scutum with one or usually two or more complete rows of punctures along parapsidal furrow; area between lateral margin of scutum and parapsidal furrow densely punctate or partially punctate anteriorly.....6
- 5(4) Frontal area above frontal spot sparsely punctate, with no more than 15–20 punctures; area between compound eye and dorsolateral margin of antennal fossa shiny and impunctate (at most with 1 or 2 punctures); base of antennal scape often yellow or ferruginous, with abrupt color change, sometimes apex

- yellow; yellow marking on mandible sometimes present.....*C. collusor* (see also *C. papuana* description)
- 5 Frontal area above frontal spot densely punctate, punctures occupying almost entire area; area between compound eye and dorsolateral margin of antennal fossa varied (densely punctate, sparsely punctate, with few punctures, or impunctate); base of antennal scape ferruginous to black (except yellow in specimens from Palawan), apex always black; mandible always dark brown or black.....*C. nigrolateralis* (see also *C. papuana* description)
- 6(4) Scutum with four longitudinal yellow lines; yellow spot behind pronotal lobe distinct.....7
- 6 Scutum without longitudinal lines (sometimes with two vague outer lines); yellow spot behind pronotal lobe often absent or small (sometimes distinct).....8
- 7(6) Base of antennal scape yellow; space between ocelli and upper part of compound eye densely punctate (less dense in Thai specimens).....*C. compacta*
- 7 Base of antennal scape black or with vague yellow spot; space between ocelli and upper part of compound eye shiny with few punctures (sometimes impunctate).....*C. lieftincki*
- 8(6) Gena almost impunctate with at most scattered few shallow punctures; marking on clypeus well-developed, upper lobe of marking almost reaching fronto-clypeal sulcus; frontal spot linear but distinct; paraocular area marking occupying almost entire area; supraclypeal spot well-developed.....*C. cognata*
- 8 Gena with sparse or dense and coarse punctures; marking on clypeus reduced, upper lobe of marking reaching at most half of clypeal length (sometimes absent), marking often with deep median incision (sometimes divided in half) (Figure 120, 126); frontal spot absent or at most vague; paraocular area

| | | |
|--------|---|-----------------------|
| | marking often linear; supraclypeal spot thin (sometimes divided in two small lines); Maluku Islands..... | 9 |
| 9(8) | Gena with dense and coarse punctures (interspaces smaller than puncture diameter); marking on clypeus often with deep median incision (sometimes dividing in half), upper lobe of marking sometimes absent..... | <i>C. interrupta</i> |
| 9 | Gena with scattered punctures (interspaces broader than puncture diameter); upper lobe of clypeal marking reaching almost half of clypeal length..... | <i>C. malukuensis</i> |
| 10(2) | Subapical depression on sixth sternum without small median projection between two lateral teeth..... | 11 |
| 10 | Subapical depression on sixth sternum with small projection(s) between two lateral teeth..... | 15 |
| 11(10) | Lateral teeth on subapical depression of sixth sternum long, slender, sometimes bent outward, apex usually pointed (Figures 146 and 163); East Asia (Japan, East China)..... | 12 |
| 11 | Lateral teeth on subapical depression medium, apices rounded (Figure 147 and 159); Afghanistan and India..... | 14 |
| 12(11) | Preoccipital carina distinct; marking on gena extending half to almost entire genal length (marking sometimes interrupted medially); transverse marking on pronotum well-developed, connecting (sometimes barely connected) to yellow spot on pronotal lobe; yellow spot behind pronotal lobe present; scutum usually with four longitudinal lines, sometimes only two outer lines present; scutellum with large rectangular marking..... | <i>C. takasagona</i> |
| 12 | Preoccipital carina absent, at most weak; marking on gena reduced to small spot, sometimes absent; transverse marking on pronotum absent, yellow spot on pronotal lobe vague, sometimes absent; yellow spot behind pronotal lobe | |

| | | |
|--------------------|---|--------------------------|
| | absent; scutum without longitudinal lines; scutellum often without marking..... | 13 |
| 13 ⁽¹²⁾ | Apex of apical lobe of S6 smooth; marking on clypeus occupying almost entire area..... | <i>C. flavipes</i> |
| 13 | Apex of apical lobe of S6 angulate; upper lobe of clypeal marking triangular, not reaching the upper portion of clypeus..... | <i>C. jejuensis</i> |
| 14 ⁽¹¹⁾ | Anterior portion of scutum densely punctate (interspaces mostly smaller than puncture diameters or at most equal); mesepisternum densely punctate (interspaces smaller than puncture diameters); marking on clypeus and paraocular area partially developed, upper lobe of clypeal marking at most attaining half of clypeal length; base and apex of antennal scape black or ferruginous; marking behind pronotal lobe absent..... | <i>C. rugosaclypeata</i> |
| 14 | Anterior portion of scutum sparsely punctate (interspaces mostly broader, two or more times of puncture diameter); mesepisternum sparsely punctate (interspaces broader two or more times puncture diameters, especially on lower and ventral sides); markings on clypeus and paraocular area well-developed, occupying entire area; base and apex of antennal scape often yellow; marking behind pronotal lobe present..... | <i>C. hieratica</i> |
| 15 ⁽¹⁰⁾ | Small median projection on the subapical depression on S6 pointed, without median incision..... | 16 |
| 15 | Small median projection on the subapical depression of S6 with median incision, sometimes divided into two smaller projections..... | 22 |
| 16 ⁽¹⁵⁾ | Supraclypeal area convex, lower part trituberculate and yellow..... | <i>C. litoraria</i> |
| 16 | Supraclypeal area flat or slightly concave, not trituberculate; marking usually triangular..... | 17 |
| 17 ⁽¹⁶⁾ | Paraocular area smooth with sparse small punctures (interspaces broader than 2 times punctures diameters); clypeus usually smooth and shiny with scattered small punctures, mostly along upper margin (sometimes upper portion slightly | |

- rugose); scutum with four yellow longitudinal lines; marking behind pronotal lobe usually present; area between parapsidal furrow and lateral margin of scutum shiny and impunctate; length 6.50–7.30 mm.....18
- 17 Paraocular area more or less rugose with small and coarse punctures, usually concentrated in median area; unmarked area on upper portion of clypeus strongly rugose or at least with dense coarse punctures; scutum without yellow longitudinal lines (sometimes with two vague outer lines); marking behind pronotal lobe absent; area between parapsidal furrow and lateral margin of scutum usually with punctures (sometimes absent or with few punctures in *C. hieroglyphica*), length 7.00–9.60 mm.....19
- 18⁽¹⁷⁾ T2 and T3 bands usually unbroken (sometimes slightly interrupted medially); marking behind pronotal lobe absent; Taiwan.....*C. pulchripes*
- 18 T2 and T3 bands broadly interrupted medially; marking behind pronotal lobe present; Southeast Asia.....*C. accusator*
- 19⁽¹⁷⁾ Upper lobe of clypeal marking small (often with pointed apex), not reaching middle of clypeal length; unmarked portion of clypeus strongly rugose about half to 2/3 of clypeal length; gena with sparse coarse punctures; dorsolateral area of antennal fossa adjacent to upper margin of compound eye sometimes swollen (convex) and almost impunctate; Philippine Islands.....*C. tropica*
- 19 Upper lobe of clypeal marking reaching two thirds of clypeal length, apex of marking truncate; unmarked area (about one thirds or less of clypeal length) densely punctate and sometimes rugose; gena almost impunctate with few coarse punctures; dorsolateral area of antennal fossa adjacent to upper margin of compound eye not swollen.....20
- 20⁽¹⁹⁾ Anterior portion of scutum densely punctate (interspaces less than puncture diameters), slightly less punctate on median part21
- 20 Anterior portion of scutum sparsely punctate (interspaces broader than puncture diameter or more).....*C. lepida*

- 21⁽²⁰⁾ Pronotal lobe, scutellum, hind tibia, and terga with maculations.....*C. bryanti*
- 21 Pronotal lobe, scutellum, hind tibia, and terga without maculations.....*C. sutepensis*
- 22⁽¹⁵⁾ Clypeus, paraocular, and supraclypeal areas with dense uniformly distributed coarse punctures (interspaces broader than puncture diameters on clypeus, Figure 191); dorsolateral area of antennal fossa adjacent to compound eye swollen, shiny and impunctate (at most with few punctures).....*C. carinifrons*
- 22 Clypeus, paraocular, and supraclypeal areas varied, usually smooth with few or scattered shallow punctures around margin; dorsolateral area of antennal fossa adjacent to compound eye flat, punctate or impunctate.....23
- 23⁽²²⁾ Hypoepimeral area above scrobe shiny with impunctate area occupying almost entire area; one fourth of anterior portion of scutum usually sparsely punctate with shallow punctures (interspaces one or two times broader than puncture diameters); S6 with median incision between lateral teeth of subapical depression deep, dividing median projection into two smaller projections.....24
- 23 Hypoepimeral area above scrobe densely punctate, impunctate area around scrobe distinct; one third to half of anterior portion of scutum with dense and well-defined punctures (interspaces smaller than puncture diameters); S6 with median incision between lateral teeth of subapical depression shallow, creating bilobed apex.....25
- 24⁽²³⁾ Scutum with four yellow longitudinal lines; yellow spot on pronotal lobe present; metabasitarsus dark brown; Northern Taiwan.....*C. alpicola*
- 24 Scutum usually without yellow longitudinal lines; yellow spot on pronotal lobe absent, at most vague; metabasitarsus yellow; Japan and Korean Peninsula.....*C. japonica*

- 25⁽²³⁾ Apex of T7 triangular (Figure 126 and 182), sometimes pointed; hypostomal carina usually strong (fold upward); length of lateral teeth of subapical depression on S6 longer more than twice as long as basal width; marking on paraocular area occupying almost entire area except usually the median part; labrum yellow or dark brown with yellow spot (sizes varied); transverse marking on pronotum usually not connected to yellow spot on pronotal lobe.....26
- 25 Apex of T7 slightly emarginate (Figure 188); hypostomal carina lower; length of submedian tooth on subapical depression on S6 no longer than the basal width; marking on paraocular area occupying entire area; labrum yellow; transverse marking on pronotum connected to yellow on pronotal lobe.....*C. taiwanensis*
- 26⁽²⁵⁾ Ryukyu Islands, Japan; area between parapsidal furrow and lateral margin of scutum densely punctate, partially punctate, or with few punctures; scutum usually without yellow longitudinal lines.....*C. okinawana*
- 26 India; area between parapsidal furrow and lateral margin of scutum usually densely punctate; scutum usually with four complete longitudinal yellow lines.....*C. simillima*

***Ceratina accusator* Cockerell**

FIGURE 7, 43, 77, 110, 139, 165 (see Figure section at the end of text)

Ceratina accusator Cockerell, 1919b: 249 [female and male]; Cockerell, 1920c: 624 [mentioned in key]; Cockerell, 1929: 150 [new record in Nan Province, Thailand]; van der Vecht, 1952: 56–57 [note on holotype and additional materials].

Ceratina accusator mutabilis van der Vecht. 1952: 57–59.

TYPE MATERIAL.—The female holotype of *C. accusator* in the American Museum of Natural History, **NEW YORK**, is labeled “*Ceratina accusator* Ckll.”, “Island of Penang, Baker”, and “acc. 34970”.

In 1952, van der Vecht proposed *C. accusator mutabilis* as a new subspecies of *C. accusator*. The female holotype of *C. accusator mutabilis* is in the Nationaal Natuurhistorisch Museum, **LEIDEN** (not seen). I have examined three paratypes of this subspecies from the same institution as the holotype. The female paratypes are labeled: (1) “W. Java Boenar Toge, 100–250 m, 27 November 1938, M. A. Lieftinck” and “Museum Leiden ex coll. M. A. Lieftinck” [for 1 female], (2) “E. Java 500 M W. slope of Idjen Mts, 29 June 1939, J. v. d. Vecht” and “*C. accusator mutabilis* det. J. v. d. Vecht 1951” [for 2 females].

DISTRIBUTION.—*Ceratina accusator* is known from the Malay Peninsula and Indonesia. The distribution may reach the northern part of Thailand, since a specimen from Nan [Thailand], was recorded by Cockerell (1929). I have not seen this specimens; it could have been *C. chiangmaiensis* Warrit and Lekprayoon new species.

DIAGNOSIS AND COMPARATIVE COMMENTS.—*Ceratina accusator* and *C. chiangmaiensis* are small species compared to other *Ceratinidia* (6.20–6.80 mm). In the female, the upper lobe of the marking on the clypeus is poorly developed, reaching at most half of the clypeal length. The marking on the paraocular area is short, usually reaching at most the level of the antennal socket. In both sexes, many specimens have T2 and T3 bands widely interrupted medially.

Female of the morph described as *mutabilis* differs from the typical *C. accusator* by the major reduction of yellow maculation on the body. The upper lobe of the marking on the clypeus absent, sometimes the transverse marking incised medially. Four yellow longitudinal lines on scutum and the spot behind the pronotal lobe are usually absent. Metasomal bands are highly reduced, sometimes only T5 band present. In some *mutabilis* specimens, the punctures on the clypeus, paraocular area, and frons are denser and coarser than in typical *C. accusator*.

Ceratina accusator is similar to *C. chiangmaiensis* in body size and the yellow markings. However, *C. accusator* can be distinguished from the later by the

denser, well-defined punctures on the clypeus, paraocular area, frons, vertex, anterior portion of scutum, and mesepisternum.

DESCRIPTION —Characters of *C. a. mutabilis* that differ from *C. a. accusator* are mentioned in brackets: **Female: Structure:** (1) Length 6.20–6.80 mm [6.20–7.00 mm]. Prosoma: (2) Clypeus smooth with scattered shallow punctures, mostly on upper and lateral margins; median longitudinal depressed area with vague longitudinal median carina. (3) Labrum with mixture of medium-sized and coarse punctures, and with long bristles. (4) Paraocular area below antennal fossa shiny almost impunctate, with small shallow punctures along compound eye, sometimes with scattered punctures throughout [paraocular area below antennal fossa shiny often with scattered medium-sized punctures]. (5) Inner part of antennal fossa with slightly dense medium-sized punctures along frontal carina, outer part impunctate [inner part of antennal fossa with dense medium-sized punctures along frontal carina, outer part with few punctures; area between dorsolateral area of antennal fossa and compound eye shiny and impunctate]. (6) Dorsolateral of antennal fossa area without smooth fovea. (7) Supraclypeal area below frontal carina impunctate or at most with 1–2 punctures. (8) Frons with few medium-sized punctures; no punctures on frontal spot area; vertex behind ocelli with more dense coarse punctures. (9) Space between ocelli and upper part of compound eye with few medium-sized punctures. (10) Gena shiny almost impunctate [gena shiny with slightly dense coarse punctures]. (11) Preoccipital carina not prominent; area behind ocelli slightly depressed. (12)

Hypostomal area with scattered shallow punctures and concave. Mesosoma: (13) Anterior third of scutum with small to medium-sized punctures (interspaces larger than punctures diameter); posterior two thirds of scutum shiny and almost impunctate except posterior part; few punctures along anteromedian line and parapsidal furrow, sometimes impunctate [anterior portion of scutum with dense medium-sized punctures; posterior two thirds of scutum shiny and almost impunctate except posterior part; few punctures along anteromedian line and parapsidal furrow]. (14) Lateral margin of scutum lined with one or two rows of medium-sized punctures. (15) Procoxa with round angle on outer side at base. (16) Mesepisternum with dense medium-sized punctures laterally; punctures less dense ventrally and posterolaterally near mesocoxa base. (17) Area around scrobe with conspicuous impunctate area [large conspicuous impunctate area around scrobe]. (18) Propodeal triangle finely coriaceo-reticulate; lateral area of propodeum densely and finely punctate, without patch of dense hair in anterior part. Metasoma: (19)–(21) See male. *Maculations* (yellow except as noted): Prosoma: (22) Upper lobe of inverted-T marking on clypeus at most reaching half clypeal length, upper lobe usually triangular [upper lobe of inverted-T marking of clypeus absent or small; lateral arm with median incision]. (23) Labrum dark brown to black. (24) Mandible dark brown to black. (25) Supraclypeal spot well-developed; linear with median convexity. (26) Frontal spot well-developed. (27) Marking on paraocular area linear; lower part bend inward (hook-liked); in smaller specimens marking gradually widened from top to bottom (Figure 7) [Marking on paraocular area more reduced than in *C. a. accusator*;

occupying only lower part (Figure 29)]. (28) Genal marking slightly narrowed downward; extending half to 2/3 of eye length. (29) Base of antennal scape ferruginous to black (Borneo specimens yellow at base). Mesosoma: (30) Transverse marking on pronotum rarely connected to yellow spot on pronotal lobe [transverse marking on pronotum broadly interrupted medially and not connected to yellow spot on pronotal lobe]. (31) Spot behind pronotal lobe present [spot behind pronotal lobe absent]. (32) Scutum with four longitudinal lines [scutum without yellow longitudinal lines (sometimes with vague outer lines)]. (33) Axilla black. (34) Tegula reddish-brown translucent. (35) Scutellum with rectangular marking, narrowed posteriorly (sometimes triangular shape); anterior margin with slight incision. (36) Marking on metanotum absent. (37) Protrochanter and mesotrochanter usually with small yellow markings apically. (38) Profemur with yellow spot on outer side at apex, extending basad for 1/3 of femoral length. (39) Protibia and mesotibia black with yellow marking on outer side extending almost entire tibia length (Borneo specimens mesotibia ferruginous with yellow spot at base). (40) Metatibia with yellow spot at base. (41) Tarsi ferruginous; metatarsi yellow brown. (42) Metabasitarsus yellow brown. Metasoma: (43) Metasomal bands reduced, T2 and T3 bands broadly interrupted medially; bands widened abruptly laterally; T4 and T5 bands slightly interrupted medially, no band on T6; band of T1 reduced, sometimes only to vague spot.

Male: As described for female *C. a. accusator* except as followed: *Structure:* (1) Length 6.50–6.70mm. Prosoma: (2) Clypeus surface not as smooth as in female; median longitudinal depressed area less obvious than in female. (3) Labrum with mixture of medium-sized and coarse punctures, but less dense than in female; few setae present. (4) Paraocular area below antennal fossa shiny with small shallow punctures along compound eye denser than in female. (5) Inner part of antennal fossa with clumped, not dense medium-sized punctures along frontal carina, outer part impunctate or at most with few punctures. (6) Dorsolateral of antennal fossa area with small smooth fovea. (8) Frons with scattered and clumped medium-sized punctures; vertex behind ocelli with more dense coarse punctures. (9) Space between ocelli and upper part of compound eye with few scattered medium-sized punctures. (10) Gena shiny with scattered punctured. (12) Hypostomal area with few punctures and depressed. Mesosoma: (13) Scutum with row of punctures along anteromedian line. (18) In small specimens, propodeal triangle strongly reticulated. Metasoma: (19) S6 with submedian tooth and median denticle on subapical depression (Figure 139); anterior part of S6 with coarse punctures and bristles (no bristles near tooth; bristles not dense); apical lobe not prominent. (20) T7 apically round, slightly produced in the middle and lateral. (21) Distal part of gonocoxite slightly broad, with bristles along apical margin; inner margin of gonocoxite slightly angulated.

Maculations (yellow except as noted): Prosoma: (22) Upper lobe of inverted-T marking on clypeus well-developed, reaching half of clypeal length and sometimes beyond (upper lobe sometimes with incision on upper margin); specimens from

Borneo with marking occupying almost entire clypeus except upper margin. (23) Labrum with marking. (24) Mandible black. (25) Supraclypeal spot well-developed, sometimes triangular. (26) Frontal spot more reduced than in female. (27) Marking on paraocular area well-developed; marking widened from top to bottom (Figure 110). (28) Genal marking slightly narrowed downward; extending half of eye length. (29) Base of antennal scape ferruginous (sometimes yellow). Mesosoma: (30) Transverse marking on pronotum connected to yellow spot on pronotal lobe. (38) Profemur with yellow spot on outer side at apex, extending basad for almost entire length of femur. (39) Protibia and mesotibia black with yellow marking on outer side extending for entire tibia length. (40) Metatibia with yellow marking on outer side for entire of tibia. (41) Tarsi ferruginous to yellow. (42) Metabasitarsus yellow. Metasoma: (43) Metasomal bands reduced, T2 and T3 bands broadly interrupted medially; bands widened abruptly laterally; T4 band and sometimes T5 band slightly interrupted medially, T6 band unbroken, no band on T7; T1 band reduced, sometimes only to vague spot.

SPECIMENS EXAMINED IN ADDITION TO TYPES.—13 (10♀, 3♂).

Ceratina accusator (Morph *accusator*)

INDONESIA. Java: Banka P. Mundo, 18 April 1931, J. v. d. Vecht (1♀; **LEIDEN**), 1 December 1935, J. v. d. Vecht (1♂; **LEIDEN**), 3 December 1935, J. v. d. Vecht (1♂; **LEIDEN**). Sumatra: S. Sumatra, SW. Lampong District, Mt. Tanggamoos, 1939, M. A. Lieftinck (1♀; **LEIDEN**)

MALAYSIA. Borneo: E. Borneo, Balikpapan, April 1924, Sheifmans (1♀; **LEIDEN**), Mentawir River, 50 m., October 1950, A. M. R. Wegner (1♀; **LEIDEN**); NW. Borneo, Sarawak, Santubong, 20 September–5 October 1950, M. A. Lieftinck (1♀; **LEIDEN**); S. Borneo, Sampit, 0–50 m., July–August 1953, M. A. Lieftinck (1♀; **LEIDEN**).
Penang: no collecting date, Baker (1♂; **LEIDEN**)

Ceratina accusator (Morph mutabilis)

INDONESIA. Java: E. Java 500 m. W. slope of Idjen Mts., 29 June 1939, J. v. d. Vecht (2♀, paratypes; **LEIDEN**); West Java, Dungus Iwul, 100 m., 12 December 1952, M. A. Lieftinck (2♀; **LEIDEN**), 18 March 1953, M. A. Lieftinck (1♀; **LEIDEN**)

***Ceratina alpicola* Shiokawa new status**

FIGURE 8, 44, 78, 111, 140, 166 (see Figure section at the end of text)

Ceratina japonica alpicola Shiokawa, 2002: 416 [male and female].

TYPE MATERIAL.— The male holotype is deposited at Hokkaido University, Japan, **SAPPORO** (not seen). The male paratype in Mr. Masato Shiokawa's personal collection, Hokkaido, Japan, **SAPPORO-SHIOKAWA**, is labeled "Taiwan, 15 October 1977, Yamauchi", "Paratype *C. japonica alpicola* Shiokawa", and "loc. Huanshan". The paratype is in fair condition with slight fungal infestation. The metasoma has been dissected for the purpose of genitalic and terminal segment (S6 and T7) studies.

DISTRIBUTION.—*Ceratina alpicola* is known only from the highlands in Northern Taiwan, over 1,000 m. above sea level.

DIAGNOSIS AND COMPARATIVE COMMENTS.—Punctuation pattern on the face, scutum, and mesepisternum is almost identical to that of *C. japonica*. However, the maculation on these structures is considerably different. In the female *C. alpicola* the upper lobe of the inverted-T marking on the clypeus is well-developed, reaching 2/3 of clypeal length; the marking on the paraocular area is long, slender, hook-like; the supraclypeal and frontal spots are well-developed; the transverse band on the pronotum is well-developed, often connected to the spot on the pronotal lobe; the mesepisternum has a marking behind the pronotal lobe; the scutum has four longitudinal lines; and the marking on the scutellum is rectangular, narrowed posteriorly. S6 and T7 of males of both species are similar.

DESCRIPTION—**Female:** *Structure:* (1) Length 7.90–9.55 mm. Prosoma: (2) Clypeus smooth, superficially rugose with small to medium-sized punctures along margins, mostly on upper, upper lateral, and lower parts; median impressed area present. (3) Labrum with slightly dense small and medium-sized punctures, and with some setae. (4) Paraocular area below antennal fossa smooth with few scattered small punctures. (5) Inner part of antennal fossa with sparse medium-sized punctures along frontal carina, outer part impunctate. (6) Dorsolateral area above antennal fossa without

small smooth fovea; antennal fossa shallow. (7) Supraclypeal area below frontal carina impunctate. (8) Frons with few scattered coarse punctures (some specimens with clump of punctures); vertex with fairly dense, coarse punctures. (9) Space between ocelli and upper part of compound eye almost impunctate, at most with few punctures. (10) Genal area shiny almost impunctate. (11) Preoccipital carina not prominent; area behind ocelli slightly depressed. (12) Hypostomal area almost impunctate. Mesosoma: (13) Anterior fourth to third of scutum fairly densely punctated with small to medium-sized punctures; posterior two thirds to three fourths densely punctured; along median line at least one row of punctures; few or row of punctures along parapsidal furrow. (14) Lateral margin of scutum lined with one or two rows of small punctures. (15) Procoxa with round angle on outer side at base. (16) Mesepisternum with dense medium-sized punctures laterally and ventrally; less dense posterolaterally near mesocoxal base; large impunctate area on hypoepimeral area; mesepisternum with dense long bristles. (17) Area around scrobe with large conspicuous impunctate area. (18) Propodeal triangle finely coriaceous-reticulate; lateral area of propodeum densely and finely punctate, without patch of dense hair anteriorly. Metasoma: (19)–(21) See male. *Maculations* (yellow except as noted): Prosoma: (22) Inverted-T marking on clypeus well-developed, occupying 2/3 of entire area, margin black. (23) Labrum black. (24) Mandible black. (25) Supraclypeal spot well-developed. (26) Frontal spot near frontal carina well-developed. (27) Marking on paraocular area thick linear, curved inward on lower part (hook-like), sometimes slightly interrupted medially (Figure 8). (28) Genal marking

thick linear; extending along 2/3 of eye length. (29) Base of antennal scape black.

Mesosoma: (30) Transverse marking on pronotum often connected to yellow spot on pronotal lobe. (31) Spot behind pronotal lobe present. (32) Scutum with four longitudinal lines. (33) Axilla black. (34) Tegula often reddish brown, otherwise black. (35) Scutellum with rectangular marking, narrowed posteriorly; anterior margin with small incision. (36) Marking on metanotum absent. (37) Protrochanter and mesotrochanter without marking apically. (38) Profemur dark brown with small spot at apex on both inner and outer sides. (39) Protibia ferruginous with yellow marking on outer side extending for almost entire length of tibia; mesotibia dark brown with yellow spot at base. (40) Metatibia dark brown, often with small yellow spot at base. (41) Tarsi dark brown. (42) Metabasitarsus dark brown. Metasoma: (43) Metasomal bands well-developed; T1 band almost enclosing two small black spots, T2–T5 bands unbroken, no band on T6.

Male: As described for female except as follows: *Structure*: (1) Length 6.40 mm.

Prosoma: (2) Clypeus smooth; few small punctures along margin; median longitudinal carina present. (3) Labrum smooth with few scattered small punctures. (4) Paraocular area below antennal fossa smooth with few shallow small punctures. (5) Inner part of antennal fossa with dense medium-sized punctures along frontal carina (carina stronger than in female), outer part impunctate. Mesosoma: (13) Scutum with more punctures laterally along outer side of parapsidal furrow than in female. (16) Hypoepimeral area shiny and convex. Metasoma: (19) S6 with

medium-sized submedian tooth and small median tooth on each side of subapical depression (Figure 140); anterior part of S6 with medium-sized, dense punctures and stiff long bristles (no bristles near tooth); apical lobe not prominent. (20) T7 apically slightly pointed with small keel; lateral side with round angle. (21) Distal part of gonocoxite slightly broad at apex, with bristles along apical margin; inner margin of gonocoxite rounded. *Maculations* (yellow except as noted): Prosoma: (22) Inverted-T marking on clypeus well-developed, occupying almost entire area except dorsally. (23) Labrum yellow. (24) Mandible black. (26) Frontal spot near frontal carina reduced to narrow oval. (27) Marking on paraocular area well-developed, occupying almost entire area (Figure 111). (28) Genal marking linear; extending at most half of eye length. (29) Base of antennal scape black. Mesosoma: (30) Transverse marking on pronotum reduced and interrupted medially, not connected to yellow spot on pronotal lobe. (31) Spot behind pronotal lobe absent. (32) Scutum with four reduced longitudinal lines. (35) Scutellum marking more reduced than in female, with two small marks. (36) Marking on metanotum absent. (38) Profemur dark brown with yellow spot at apex, extending basad on inner side for entire length of femur. (39) Protibia and mesotibia ferruginous with yellow markings on outer sides extending for almost entire lengths of tibiae. (40) Metatibia ferruginous with yellow spot at base, extending almost entire length of tibia. (41) Tarsi dark brown. (42) Metabasitarsus ferruginous. Metasoma: (43) Metasomal bands reduced and narrow; T1 band vague, almost absent, T2–T6 bands unbroken but narrow (or slightly interrupted medially), no band on T7.

SPECIMENS EXAMINED IN ADDITION TO TYPES.—2♀.

TAIWAN. Huanshan: 15 October 1977, K. Yamauchi (2♀; **SAPPORO-SHIOKAWA**)

***Ceratina bicuneata* Cockerell**

FIGURE 9, 45, 79 (see Figure section at the end of text)

Ceratina bicuneata Cockerell, 1918: 143 [female]; Cockerell, 1920b: 207 [male];
Cockerell, 1920c: 624 [mentioned in key]; van der Vecht, 1952: 65–66
[redescription of female and male].

TYPE MATERIAL.—The female type of *C. bicuneata* in the United States Natural Museum of Natural History, The Smithsonian’s Institution, **WASHINGTON, D.C.**, is labeled “Baguio, Benguet, Baker”, “Type No. 23764 U.S.N.M.”, and “*Ceratina bicuneata* Ckll. TYPE”. The type is in good condition. I designate as lectotype the type of *C. bicuneata* in **WASHINGTON, D. C.**, and add a label “[on red label] *Ceratina bicuneata* Cockerell, Lectotype, N. Warrit, 2007”.

DISTRIBUTION.—*Ceratina bicuneata* is known only from Luzon Island of the Philippines.

DIAGNOSIS AND COMPARATIVE COMMENTS.—Female of *C. bicuneata* can be distinguished from other *Ceratinidia* by the uniformly dense coarse punctures throughout the clypeus, paraocular area, antennal fossa, and frons. The interspaces between punctures are broader than puncture diameter on clypeus and paraocular area. The anterior portion of the scutum is sparsely punctate with medium-sized punctures; the posterior margin has at most two rows of punctures; the median area of the scutum is impunctate and shiny. The procoxa is depressed laterally with a pointed projection on the outer side at the base.

I have not examined male specimens of *C. bicuneata*. For details of the male, see van der Vecht (1952) or Cockerell (1920b).

DESCRIPTION.—**Female:** *Structure:* (1) Length 8.70 mm. Prosoma: (2) Clypeus with dense coarse punctures throughout (interspaces broader than puncture diameter); setae on most punctures; median longitudinal impressed area prominent. (3) Labrum with mixture of medium-sized and coarse punctures, and with many long bristles. (4) Paraocular area below antennal fossa with dense coarse punctures as on clypeus. (5) Inner part of antennal fossa with dense coarse punctures along frontal carina, outer part with fairly dense coarse punctures. (6) Dorsolateral area of antennal fossa area without small smooth fovea; shiny convex impunctate area between dorsolateral area of antennal fossa and compound eye present. (7) Supraclypeal area below frontal carina fairly dense punctate. (8) Frons with scattered and clumped coarse punctures; vertex not as densely punctate as other facial areas. (9) Space between ocelli and

upper part of compound eye with few scattered punctures. (10) Genal area shiny, almost impunctate. (11) Preoccipital carina not prominent; area behind ocelli slightly curved depressed. (12) Hypostomal area with fairly dense coarse punctures.

Mesosoma: (13) Anterior fourth of scutum with mixture of small to medium-sized punctures (punctures remote); posterior three fourth of scutum shiny, nearly impunctate. (14) Lateral margin of scutum lined with one row of coarse punctures. (15) Procoxa depressed laterally with pointed angle on outer side at base. (16) Mesepisternum with dense coarse punctures laterally and slightly less dense ventrally, much less dense posterolaterally near mesocoxal base; hypoepimeral area with large shiny impunctate area. (17) Area around scrobe with large conspicuous impunctate area. (18) Propodeal triangle finely coriaceous-reticulate; lateral area of propodeum densely and finely punctate, without patch of dense hair anteriorly. Metasoma (19)–(21) Not seen. *Maculations* (yellow except as noted): Prosoma: (22) Median lobe of inverted-T marking on clypeus only slightly protruding upward; lateral arm slightly and gradually reduced laterally. (23) Labrum dark brown. (24) Mandible dark brown. (25) Supraclypeal spot well-developed; upper margin resembling crown with 3 points. (26) Frontal spot reduced to small triangular spot near frontal carina. (27) Marking on paraocular area largely occupying lower part of area and sharply obliquely discontinued near level of antennal socket (Figure 9.) (28) Genal marking thick, slightly narrowed downward, extending for 1/5 to 1/4 of eye length. (29) Base of antennal scape ferruginous with vague yellow stripe. Mesosoma: (30) Transverse marking on pronotum scarcely connected to yellow spot on pronotal lobe. (31) Spot

behind pronotal lobe large. (32) Scutum with vague inner longitudinal lines. (33) Axilla black. (34) Tegula dark reddish-brown translucent. (35) Scutellum with large rectangular marking; anterior margin of marking with small incision. (36) Metanotum with vague transverse yellow band. (37) Protrochanter and mesotrochanter with marking apically. (38) Profemur dark brown with yellow spot at base, extending basad on inner side for entire length of femur. (39) Protibia and mesotibia ferruginous with yellow marking on outer side extending almost entire tibial length. (40) Metatibia dark ferruginous with small yellow spot at base. (41) Tarsi ferruginous. (42) Metabasitarsus ferruginous. Metasoma: (43) Metasomal bands well-developed and unbroken; T1 band not enclosing black spot, T2 band widened laterally, no band on T6.

***Ceratina bryanti* Cockerell**

FIGURE 10, 46, 80, 112, 141, 167 (see Figure section at the end of text)

Ceratina bryanti Cockerell, 1919a: 175 [male]; van der Vecht, 1952: 51–54

[redescription]; Baker, 2002a: 361, fig. 5 [indicated synonymys].

? *Ceratina denticulata* Wu, 1963: 86, 91, fig. 82 [female and male; so far as can be judged from a disintegrated allotype and from Wu's original description *C. denticulata* might be a synonym of *C. bryanti* or *C. hieroglyphica*].

TYPE MATERIAL.—The male holotype of *C. bryanti* in the United States National Museum of Natural History, **WASHINGTON, D. C.**, is labeled “Pelaboean Ratoe Java” “Bryant & Palmer Coll.”, and “Type No. 20706 U.S.N.M.”.

The male holotype of *C. denticulata* is in Institution of Zoology, Academia Sinica (Chinese Academy of Sciences), **BEIJING** (not seen). The female allotype in the same institution as the holotype is labeled “[locality in Chinese], 200 m., 1956. VI. 11”, “Allotype”, “IOZ (E) 206055”, and “*Ceratina denticulata* Wu ♀”. The allotype was in poor condition when it arrived at the University of Kansas for examination. The head and metasoma fell apart from the mesosoma, the head was missing from inside the container carrying the type; most parts of the legs segments broke from the mesosoma.

DISTRIBUTION.—*Ceratina bryanti* is known from the Malay Peninsula and some of the Indonesian Islands (e.g., Sumatra, Java, and Bali). *Ceratina denticulata* is known from South China.

DIAGNOSIS AND COMPARATIVE COMMENTS.—*Ceratina bryanti* superficially resembles *C. lepida* from India, especially in the pattern of punctation on clypeus and paraocular area. However, both female and male of *C. bryanti* can be distinguished from *C. lepida* by the dense punctation on the anterior part of the scutum and by the flat posterior area of the vertex, behind the ocelli. The subapical depression of S6 in

male *C. bryanti* has a lateral tooth and one median projection; unlike *C. lepida*, the median projection lacks a median incision.

Based on Wu's description (1963) and illustrations of *C. denticulata*, it is somewhat convincing to think that *C. denticulata* is a synonym of *C. bryanti* or *C. hieroglyphica*. The marking on the clypeus and paraocular area below antennal fossa, the submedian teeth on S6 (Wu's illustration did not indicate the presence of a small median denticle between the submedian teeth), and T7 of the male of *C. denticulata* is similar to that of *C. bryanti* and *C. hieroglyphica*. However, markings on the pronotum, scutum, and legs from the female allotype of *C. denticulata* are absent or more reduced than the two latter species.

DESCRIPTION—**Female:** *Structure:* (1) Length 5.70–9.20 mm. Prosoma: (2) Clypeus with median longitudinal impressed impunctate area; lateral part of impressed area with dense small to medium-sized punctures; lower part of clypeus rugose with few scattered shallow punctures. (3) Labrum with mixture of medium-sized and coarse punctures and many short bristles. (4) Paraocular area below antennal fossa with medium-sized to coarse punctures clumped together on middle part, few punctures on lower part. (5) Inner part of antennal fossa with coarse punctures along frontal carina, outer part with few punctures. (6) Dorsolateral area of antennal fossa without smooth fovea. (7) Supraclypeal area below frontal carina with 1–2 punctures and ventral depression. (8) Frons and vertex with dense and coarse punctures. (9) Space between ocelli and upper part of compound eye with scattered coarse punctures. (10) Gena

shiny almost impunctate. (11) Preoccipital carina prominent; area behind ocelli slightly flattened. (12) Hypostomal area with scattered medium-sized punctures; hypostomal carina slightly prominent. Mesosoma: (13) Anterior third of scutum with dense medium-sized punctures; posterior two thirds of scutum shiny and impunctate except posterior margin; one row of punctures along anteromedian line. (14) Lateral margin of scutum lined with one or two rows of medium-sized punctures. (15) Procoxa with round angle on outer side at base. (16) Mesepisternum with dense coarse punctures laterally; punctures slightly less dense ventrally and posterolaterally near mesocoxal base; hypoepimeral surface convex and impunctate in some specimens. (17) Area around scrobe with conspicuous oblique convex impunctate area. (18) Propodeal triangle finely coriaceous-reticulate; lateral area of propodeum densely and finely punctate, without patch of dense hair on anterior part. Metasoma: (19)–(21) See male. *Maculations* (yellow except as noted): Prosoma: (22) Upper lobe of inverted-T marking on clypeus reaching half to at most 2/3 of clypeal length (sometimes with incision on upper margin); lateral arms of marking with small hook-like point downward. (23) Labrum black. (24) Mandible black. (25) Supraclypeal spot well-developed. (26) Frontal spot thick. (27) Marking on paraocular area linear and curving inward along lower margin (hook-like) (Figure 10). (28) Genal marking slightly narrowed downward; extending 2/3 of eye length. (29) Base of antennal scape black. Mesosoma: (30) Transverse marking on pronotum unbroken, rarely connected to yellow spot on pronotal lobe. (31) Spot behind pronotal lobe absent (sometimes vague). (32) Scutum with four longitudinal lines. (33) Axilla black. (34)

Tegula reddish-brown translucent. (35) Scutellum with large marking occupying entire area except the anterior part (in some specimens narrowed posteriorly); small incision on anterior margin of marking. (36) Marking on metanotum absent. (37) Protochanter and mesotrochanter usually each with small yellow marking apically. (38) Profemur dark brown, often with yellow spot on inner side. (39) Protibia dark brown with yellow marking on outer side extending 2/3 of tibial length distally from base; mesotibia dark brown with yellow spot at base. (40) Metatibia with yellow spot at base. (41) Tarsi dark brown to black. (42) Metabasitarsus black. Metasoma: (43) Metasomal bands narrow but well developed and unbroken; no band on T6; T1 band with wide marking not enclosing black spots.

Male: As described for female except as follows: *Structure*: (1) Length 5.40–8.70 mm. Prosoma: (2) Clypeal surface with more rugose appearance, with median longitudinal impressed area broader and shallower. (3) Labrum with fewer setae than in female. (4) Paraocular area below antennal fossa rugose with small to medium-sized or coarse punctures clumped on middle and upper parts, few punctures on lower part. (10) Gena shiny with few shallow punctures. Mesosoma: (13) Anterior portion of scutum with dense medium-sized punctures; row of punctures along anteromedian line and parapsidal furrow so that punctures of median part denser than in female; posterior part with more punctures than in female. (14) Lateral margin of scutum lined with two or more rows of medium-sized punctures. (18) Lateral area of propodeum densely and finely punctate, with small patch of dense hair anteriorly.

Metasoma: (19) S6 with medium-sized submedian tooth and small median tooth on subapical depression (Figure 141); anterior part of S6 with coarse and dense punctures and long stiff bristles (no bristles near tooth area); apical lobe prominent. (20) T7 apically pointed with prominent angle. (21) Distal part of gonocoxite broad, with bristles along apical margin; inner margin of gonocoxite slightly round.

Maculations (yellow except as noted): Prosoma: (22) Clypeal marking as in female but more extensive (sometimes with blunted upper lobe). (23) Labrum black (sometimes vague yellow). (26) Frontal spot linear (more reduced than in female). (27) Marking on paraocular area linear but abruptly broadened on lower end (Figure 112.) (28) Genal marking slightly narrowed downward, extending half of eye length.

Mesosoma: (32) Scutum without yellow longitudinal lines (some specimens with two outer lines). (35) Scutellum with marking narrowed posteriorly, small incision on anterior margin. Metasoma: (43) Metasomal bands either as in female or more reduced, T2 and T3 with bands widely interrupted medially, T4 with band slightly interrupted; marking on T1 more reduced than in female.

SPECIMENS EXAMINED IN ADDITION TO THE TYPES.—42 (33♀ 9♂).

MALAYSIA. Pahang: Cameron Highlands, no collecting date, D. B. Baker (1♂; **LAWRENCE-BAKER**), 5,000 ft, 22 April 1973, C. G. Roche (1♀; **LAWRENCE-BAKER**), 25 April 1973, C. G. Roche (1♀, 3♂; **LAWRENCE-BAKER**). Perak: Cameron Highlands, m. 19, Tapah-Tanah, Rata rd., c. 2,000 ft, 3 April 1982, D. B.

Baker (1♀; **LAWRENCE-BAKER**); Tapah Hill, 29 November 1973, C. G. Roche (1♀; **LAWRENCE-BAKER**).

INDONESIA. Java: Boyolali, 10 May 1973, 450 m, C.D. Michener (9♀, 1♂; **LAWRENCE**), 15 km W. of Boyolali, 10 May 1973, 1,500 m, C.D. Michener (3♀, 2♂; **LAWRENCE**), South Slope of Mt. Merbabu, 26 May 1973, 1,900 m, C.D. Michener (10♀, 1♂; **LAWRENCE**); Bogor, 15 May 1973, C.D. Michener (3♀; **LAWRENCE**); Cibodas, 16 May 1973, 1,480 m, C.D. Michener (1♂; **LAWRENCE**); Wadas Putin, S. of Dieng Plateau, 22 May 1973, C.D. Michener (1♀; **LAWRENCE**).
Sumatra: Bukittinggi, 19 December 1978, E. S. Ross (1♀; **SAN FRANCISCO**); Fort de Kock, 920 m, 1926, E. Jacobson (1♀; **BERLIN**); Pangherang-Pisang, October 1890–March 1891, E. Modigliani (1♀; **SAN FRANCISCO**)

Ceratina carinifrons Baker

FIGURE 11, 47, 81, 113, 142, 168 (see Figure section at the end of text)

Ceratina carinifrons Baker, 2002b: 342, fig. 3,4, and 11 [female].

Ceratina alexandrae Baker, 2002b: 343–344, fig. 5 and 6 [female]. **new synonym**

TYPE MATERIAL.—The female holotype of *C. carinifrons* in the Hope Entomological Collections, Oxford University, **OXFORD**, is labeled “Indonesia. Sulawesi / II / P4 / Area: 3 / Date: 15.12.00 / leg. A. M. Klein”, “SULAWESI (Central) Napu Vall., ca.

100km SE Palu, Alitupu. C. 1100 m. 15 December 2000, A. M. Klein [Area 3]”, and “HOLOTYPE *Ceratina (Ceratinidia) carinifrons* Baker, D. B. Baker det. 2001”.

Two female paratypes of *C. carinifrons* in the University of Kansas Natural History Museum and Biodiversity Research Center, **LAWRENCE**, are labeled “Indonesia. Sulawesi / IV / P4 (P5 in another type) / Area: 10 / Date: 07.01.01 / leg. A. M. Klein”, “SULAWESI (Central) Napu Vall., ca. 100km SE Palu, Wuasa. C. 1100 m. 7 January 2001, A. M. Klein [Area 10]”, and “PARATYPE *Ceratina (Ceratinidia) carinifrons* Baker, D. B. Baker det. 2001”. All types are in good condition.

The female holotype of *C. alexandrae* in the Hope Entomological Collections, Oxford University, **OXFORD**, is labeled “Indonesia. Sulawesi / IV / P6 / Area: 10 / Date: 07.01.01 / leg. A. M. Klein”, “SULAWESI (Central) Napu Vall., ca. 100km SE Palu, Wuasa. C. 1100 m. 7 January 2001, A. M. Klein [Area 10]”, and “HOLOTYPE *Ceratina (Ceratinidia) alexandrae* Baker, D. B. Baker det. 2001”. The female paratype of *C. alexandrae* in the University of Kansas Natural History Museum and Biodiversity Research Center, **LAWRENCE**, is labeled “Indonesia. Sulawesi / IV / P5 / Area: 10 / Date: 07.01.01 / leg. A. M. Klein”, “SULAWESI (Central) Napu Vall., ca. 100km SE Palu, Wuasa. C. 1100 m. 7 January 2001, A. M. Klein [Area 10]”, and “PARATYPE *Ceratina (Ceratinidia) alexandrae* Baker, D. B. Baker det. 2001”. The holotype is in good condition; the paratype is missing an antenna, otherwise in good condition.

Baker (2002) differentiated *C. carinifrons* from *C. alexandrae* by the “...longer vertex, the strong, laterally displaced, excrescences of the supraclypeal

area, the short supraocellus sulcus; the longer vertex, and the broader genae.” and vice versa for *C. alexandrae* by “the simply convex upper paraocular area, the nature of the posterior delimitation of the ocellar area, the relatively shorter vertex and narrower gena, and the reduced maculation, notably the absence of frontal maculae, the dark pronotal lobes and the absence of a mesepisternal post-pronotal macula”. However, even though the excrescence of the supraclypeal area above the antennal fossa is conspicuously stronger in types of *C. carinifrons* than in types of *C. alexandrae*, other characters (longer vertex and gena or the maculation) are not good distinguishing characters for these species. I have examined additional specimens besides the types that were collected near the type localities, and found that most specimens of *C. alexandrae* (with simple convex upper area above the antennal fossa) have the same yellow pattern on the face and pronotal area as in *C. carinifrons*. The length of vertex and gena of *C. alexandrae* is also similar to *C. carinifrons*. None of the additional specimens besides the types have strong excrescences above the antennal fossa; it appears that the excrescences are variable among individuals in the species. The one male that shares characters of these two species is from the type locality.

Based on the congruence of characters discussed above between *C. carinifrons* and *C. alexandrae*, I am treating *C. alexandrae* as a darker form of *C. carinifrons*.

DISTRIBUTION.— *Ceratina carinifrons* is only recorded from Northeast and Central Sulawesi, Indonesia.

DIAGNOSIS AND COMPARATIVE COMMENTS.—*Ceratina carinifrons* is similar to the sympatric species, *C. rugifrons*, but can be distinguished from the latter by the less dense punctures (interspaces 2–3 times puncture diameter) on the clypeus and paraocular area, by the absence of (or at most with few) punctures on the antennal fossa, by the sparsely punctate frons and vertex, and by the absence of a row of punctures along the parapsidal furrow and median line of the scutum.

In the male *C. carinifrons*, unlike *C. rugifrons*, the medium-sized submedian teeth on the subapical depression of S6 are close together with a small median denticle between them, and the apical lobe of S6 is not prominent.

DESCRIPTION—**Female:** *Structure:* (1) Length 6.90–8.00 mm. Prosoma: (2) Clypeus slightly rugose with scattered medium-sized (not well-defined) punctures; median longitudinal impressed area ventrally prominent and more rugose than other parts; median longitudinal carina present. (3) Labrum with scattered medium-sized, and with many long bristles. (4) Paraocular area below antennal fossa with scattered medium-sized punctures. (5) Inner part of antennal fossa with dense coarse punctures along frontal carina, outer part with few or scattered medium-sized punctures. (6) Dorsolateral part of antennal fossa area without smooth fovea; large shiny convex

impunctate area between dorsolateral area of antennal fossa and compound eye. (7) Supraclypeal area below frontal carina fairly dense punctate. (8) Frons with scattered and clumped coarse punctures, clumped punctures in front of median ocellus with two small shiny impunctate areas laterally; vertex with scattered punctures, most of punctures concentrated posteriorly near preoccipital carina. (9) Space between ocelli and upper part of compound eye with scattered punctures. (10) Genal area shiny, sparsely punctate with shallow punctures. (11) Preoccipital carina not prominent; area behind ocelli slightly depressed. (12) Hypostomal area with scattered shallow punctures. Mesosoma: (13) Anterior third of scutum with large dense punctures; posterior part with dense small to medium-sized punctures; area between anterior and posterior parts almost impunctate with few punctures along anteromedian line and/or parapsidal furrow. (14) Lateral margin of scutum lined with one row of coarse punctures. (15) Procoxa more or less triangular, outer margin angulate. (16) Mesepisternum with dense uniformly coarse punctures laterally and slightly less dense posterolaterally near mesocoxal base, ventral side with dense fine punctures. (17) Area around scrobe with large conspicuous impunctate area. (18) Propodeal triangle reticulated; lateral area of propodeum densely punctate with medium-sized punctures, with small patch of dense hair anteriorly. Metasoma: (19)–(21) See male. *Maculations* (yellow except as noted): Prosoma: (22) Upper lobe of inverted-T marking reaching at most half of clypeal length (sometimes upper lobe absent, median incision present); lateral arm terminally constricted, often attaching to lateral spot. (23) Labrum dark brown to black. (24) Mandible dark brown to black. (25)

Supraclypeal spot well-developed. (26) Frontal spot near frontal carina small almost absent. (27) Marking on paraocular area curved inward on lower part (hook-like); marking not extending above level of antennal socket (Figure 11). (28) Genal marking thick, slightly narrowed downward, extending half to 2/3 of eye length. (29) Base of antennal scape ferruginous or black. Mesosoma: (30) Transverse marking on pronotum (sometimes interrupted medially) often connected to yellow spot on pronotal lobe, this spot sometimes absent. (31) Spot behind pronotal lobe often large (absent in large specimens). (32) Scutum with four longitudinal lines (sometimes two inner lines absent). (33) Axilla black. (34) Tegula dark reddish-brown translucent. (35) Scutellum with large rectangular marking (sometimes narrowed posteriorly and triangular); anterior margin of marking with small incision. (36) Marking on metanotum absent. (37) Protrochanter and mesotrochanter with yellow markings apically. (38) Profemur dark brown with yellow spot at base, extending distad on inner side for entire length of femur (sometimes absent). (39) Protibia and mesotibia ferruginous with yellow markings on outer sides extending almost entire tibial lengths (sometimes mesotibia with yellow spot only at base). (40) Metatibia dark ferruginous with small yellow spot at base. (41) Tarsi ferruginous or dark brown. (42) Metabasitarsus ferruginous or dark brown. Metasoma: (43) Metasomal bands well-developed; T1 band not enclosing black spots; T2 and T3 bands interrupted medially and bands widened laterally, T4 and T5 bands usually unbroken, no band on T6.

Male: as described for female except as follows: *Structure:* (1) Length 6.95–7.40 mm. Prosoma: (2) Clypeus with scattered medium-sized punctures; median longitudinal impressed area absent; median longitudinal carina vague. (3) Labrum with few medium-sized punctures, and with few setae. (4) Paraocular area below antennal fossa with fairly dense, medium-sized punctures. (6) Dorsolateral part of antennal fossa area without small smooth fovea; dorsolateral area of antennal fossa and compound eye with more punctures than in female. (10) Genal area shiny, more densely punctate than in female. (12) Hypostomal area ventrally depressed.

Mesosoma: (14) Lateral margin of scutum lined with one or two rows of coarse punctures. (15) Procoxa with rounded angle on outer side at base. (17) Area around scrobe smaller than in female. Metasoma: (19) S6 with medium-sized submedian teeth and small median tooth (divided apically) on subapical depression (Figure 142); anterior part of S6 with coarse and dense punctures and stiff bristles (no bristles near tooth area); apical lobe not prominent. (20) T7 apically slightly pointed with rounded lateral angle. (21) Distal part of gonocoxite broad, with bristles along apical margin; inner margin of gonocoxite slightly angulated. *Maculations* (yellow except as noted):

Prosoma: (22) Inverted-T marking well-developed, occupying almost entire area (sometimes not reaching half of clypeal length), except upper margin. (23) Labrum with yellow marking occupying entire area. (24) Mandible black. (27) Marking on paraocular area well-developed, occupying almost entire area but not above level of antennal socket (Figure 113). (28) Lateral genal marking thick, slightly narrowed downward, extending half of eye length. (29) Base and apex of antennal scape

yellow or vague spots. Mesosoma: (30) Yellow transverse marking on pronotum connected to yellow spot on pronotal lobe. (31) Yellow spot behind pronotal lobe large; lateral area of mesepisternum sometimes with yellow streak above and in front of midcoxa. (34) Tegula dark reddish-brown translucent, sometimes with small yellow spot. (35) Scutellum with large rectangular marking, anterior margin with small incision. (36) Small yellow marking on metanotum present (sometimes absent); metepisternum sometimes with small spot. (38) Profemur yellow throughout, ferruginous at base and on inner side; lower part of procoxa sometimes with yellow transverse marking. (39) Protibia and mesotibia with yellow extending almost entire length. (40) Metatibia yellow. (41) Tarsi yellow, sometimes ferruginous. (42) Metabasitarsus yellow. Metasoma: (43) Metasomal bands well-developed or reduced; T1 band enclosing two small black spots (sometimes not enclosing); T2 and T4 bands sometimes interrupted medially, T3 bands interrupted medially, no band on T7.

SPECIMENS EXAMINED IN ADDITION TO TYPES.—15 (9♀, 6♂).

INDONESIA. Sulawesi: Central Sulawesi, Napu Valley ca.100 km. SE of Palu, Wuasa, 1,100 m., 14 December 2000, A. M. Klein (1♀; **LAWRENCE-BAKER**); NE Sulawesi, 47 km wsw Kotamobagu, Dumoga-Bone National Park, Toraut (forest edge), 211 m., May 1985, G. R. Else (8♀, 3♂; **LAWRENCE-BAKER** and **LONDON**), June 1985, G. R. Else (3♂; **LAWRENCE-BAKER** and **LONDON**).

Ceratina chiangmaiensis Warrit and Lekprayoon, new species

FIGURE 12, 48, 82 (see Figure section at the end of text)

TYPE MATERIAL.—The female holotype and two paratypes are deposited in the University of Kansas Natural History Museum, **LAWRENCE**. They are in excellent condition and are labeled “THAILAND: Chiang Mai Prov., Ahn Kang, W. of Fang, 6 February 1993, S. Boongird, C. Michener, S. Malaipan”. Three additional paratypes, with the same data are deposited, one each, in the Natural History Museum, **LONDON**; the United States National Museum of Natural History, The Smithsonian’s Institution, **WASHINGTON, D.C.**; and the Natural History Museum of Chulalongkorn University, **BANGKOK**.

The type material was taken from nest burrows in broken or cut dead stems of *Lantana* sp. No immature stages or provisional cells were found; the active season must have been at another time of year (C.D. Michener, personal communication).

ETYMOLOGY.—This species is named after Chiang Mai Province, Thailand, where all of the types were collected.

DISTRIBUTION.—*Ceratina chiangmaiensis* is known only from one locality in Chiang Mai Province, Thailand.

DIAGNOSIS AND COMPARATIVE COMMENTS.—*Ceratina chiangmaiensis* is similar to *C. accusator*, but even smaller than the later species (5.15–6.00 mm). A character that separates *C. chiangmaiensis* from *C. accusator* is the reduction of punctures, mostly on the facial area and the scutum. The paraocular area is smooth, shiny, and sometimes impunctate; the frons is sparsely punctate with shallow punctures; the clypeus is not as punctate and rugose as in *C. accusator*; the anterior part of the scutum is sparsely punctate with shallow punctures; the mesepisternum is sparsely punctate (interspaces between punctures are larger than the puncture diameter); and the yellow maculation behind the pronotal lobe is absent.

DESCRIPTION—**Female:** *Structure:* (1) Length 5.15–6.00 mm. Prosoma: (2) Clypeus smooth with scattered shallow punctures, mostly on upper and lateral margins; median longitudinal depressed area with longitudinal median carina vague. (3) Labrum with mixture of medium-sized and coarse punctures, and with long bristles. (4) Paraocular area below antennal fossa shiny, almost impunctate, with small shallow punctures along compound eye. (5) Inner part of antennal fossa with rather dense medium-sized punctures along frontal carina, outer part impunctate. (6) Dorsolateral part of antennal fossa without smooth fovea. (7) Supraclypeal area below frontal carina impunctate. (8) Frons with few medium-sized punctures; vertex behind ocelli with denser, coarse punctures. (9) Space between ocelli and upper part of compound eye with few medium-sized punctures. (10) Gena shiny, almost impunctate. (11) Preoccipital carina not prominent; area behind ocelli slightly

depressed. (12) Hypostomal area slightly depressed (sometimes rugose). Mesosoma: (13) Anterior third of scutum with small to medium-sized punctures (interspaces larger than puncture diameters); posterior two thirds of scutum shiny and almost impunctate except posterior margin; few punctures along anteromedian line and parapsidal furrow. (14) Lateral margin of scutum lined with one or two rows of medium-sized punctures. (15) Procoxa with rounded angle on outer side at base. (16) Mesepisternum with medium-sized punctures not as dense as in *C. accusator*; punctures noticeably less dense ventrally and posterolaterally near mesocoxal base. (17) Area around scrobe with large conspicuous impunctate area. (18) Propodeal triangle finely coriaceo-reticulate; lateral area of propodeum densely and finely punctate, with small patch of dense hair anteriorly. Metasoma: (19)–(21) Unknown. *Maculations* (yellow except as noted): Prosoma: (22) Upper lobe of inverted-T marking of clypeus reaching half clypeal length (sometimes with small incision on upper margin of marking). (23) Labrum black. (24) Mandible black. (25) Supraclypeal spot well-developed. (26) Frontal spot well-developed. (27) Marking on paraocular area linear slightly widened from top to bottom (Figure 12). (28) Lateral facial marking slightly narrowed downward; extending half of eye length. (29) Base of antennal scape black. Mesosoma: (30) Transverse marking on pronotum interrupted medially and rarely connected to yellow spot on pronotal lobe. (31) Spot behind pronotal lobe varied. (32) Scutum with four longitudinal lines. (33) Axilla black. (34) Tegula reddish-brown translucent. (35) Scutellum with triangular small marking; anterior margin with slight incision. (36) Marking on metanotum absent.

(37) Protrochanter and mesotrochanter with small yellow marking apically. (38) Profemur with yellow spot on outer side at apex. (39) Protibia and mesotibia black with yellow marking on outer side extending almost entire tibial length. (40) Metatibia with yellow spot at base. (41) Tarsi dark brown; metatarsi yellow brown. (42) Metabasitarsus yellow brown. Metasoma: (43) Metasomal bands narrow but well developed and unbroken, T2 and T3 bands widened abruptly laterally; no band on T6; T1 band with wide marking not enclosing black spots.

Male: Unknown

***Ceratina cognata* Smith**

FIGURE 13, 49, 83, 114, 143, 169 (see Figure section at the end of text)

Ceratina cognata Smith, 1879: 94 [male]; van der Vecht, 1952: 69–73 [redescription of female and male]; Wu, 2000: 168–169. [record from Southern China]

Ceratina conscripta Cockerell, 1919b: 247 [male]; Cockerell, 1920c: 624 [mentioned in key]

Ceratina selangorensis Cockerell, 1919b: 248 [male]

Ceratina laosorum Cockerell, 1929: 151 [female]

TYPE MATERIAL.—The male type of *C. cognata* in the Natural History Museum, LONDON, is labeled “Celebes”, “57 101”, and “Type # 17 b 213”. The type specimen

is in good condition. Since Smith and subsequent authors did not indicate how many specimens Smith had nor did they designate the type or lectotype for the name *C. cognata*, I designate as lectotype the male type of *C. cognata* in **LONDON**, and add a red label “*Ceratina cognata* Smith, Lectotype, N. Warrit, 2007”.

The male type of *C. conscripta* is in the Natural History Museum, **LONDON** (not seen). However, van der Vecht (1952) made a note that although this type is from Penang, Malaysia, the color pattern agreed well with type of *C. cognata* from Celebes (Sulawesi). Cockerell (1919b) indicated the label on the type as “Island of Penang (Baker, 9286)” at the end of the species description.

The male type of *C. selangorensis* in the Natural History Museum, **LONDON**, is labeled “Selangor Baker”, “9287”, and “Type # 17 b 237”. The type specimen is in good condition; however, the yellow maculation is yellowish-red, presumably from the use of cyanide as the killing agent. I designate as lectotype the female type of *C. selangorensis* in **LONDON**, and add a red label “*Ceratina selangorensis* Cockerell, Lectotype, N. Warrit, 2007”. I have examined this type and agree with van der Vecht’s (1952) comment that it is a darker form of *C. cognata*. Punctuation and yellow maculation of *C. selangorensis* are as in to *C. cognata*, except that in *C. selangorensis* the transverse band on T2–T4 are vague spots, and the remaining segments are black.

The female holotype of *C. laosorum* in the Natural History Museum, **LONDON**, is labeled “Brit. Mus. 1933–567” and “Type # 17 b 223”. The type is in

good condition and falls within the range of variations of *C. cognata*; it is a smaller specimen with extensive maculation on the tibiae and tarsi.

DISTRIBUTION.—This widely distributed species can be found from Southern China, the Indochina region to the Malay Peninsula and the Indonesian Islands, including Sulawesi, but is not found in the Philippines.

DIAGNOSIS AND COMPARATIVE COMMENTS.—*Ceratina cognata* is closely resembles *C. compacta*. Punctuation in *C. cognata* is very similar to that of *C. compacta* in density, puncture size, and distribution; with the exception of the density of punctures on the posterolateral mesepisternal area near the mesocoxal base. In *C. cognata*, the punctures are better separated and well-defined; but in *C. compacta*, the punctures are dense and the surface dull (this character is more evident in most females than in males). Color patterns of the two species are also similar; however, *C. cognata* can be easily distinguished from *C. compacta* by the absence of yellow maculation on the labrum (only in female), mesoscutum, and sometimes the mesepisternum (Thai *C. cognata* have a small spot behind the pronotal lobe on the mesepisternum). S6 of male *C. cognata* has a V-shaped ridge and a small lateral tooth on each side of the subapical depression.

Yellow maculation is more extensive in populations from Laos and Thailand. Most female *C. cognata* from this region have all of the tarsi yellow, and sometimes the yellow spot is present behind the pronotal lobe on the mesepisternum.

DESCRIPTION—**Female:** *Structure:* (1) Length 5.65–9.30 mm. Prosoma: (2) Clypeus slightly wrinkled with shallow scattered punctures on margins; few punctures on yellow marking, mostly on the lower part; longitudinal median carina vague (sometime absent). (3) Labrum with dense coarse punctures, and with many long stiff bristles. (4) Paraocular area below antennal fossa with shallow scattered punctures. (5) Inner part of antennal fossa with medium-sized to coarse punctures along frontal carina, outer part impunctate or at most with few punctures. (6) Dorsolateral part of antennal fossa with small smooth fovea. (7) Supraclypeal area below frontal carina impunctate with ventral depression. (8) Frons impunctate or with few strong punctures in lower part of antennal fossa area, but with dense and coarse punctures in upper part, and throughout vertex. (9) Space between ocelli and upper part of compound eye with few well-defined punctures (sometimes impunctate). (10) Gena shiny, almost impunctate. (11) Preoccipital carina not prominent; area behind ocelli slightly depressed. (12) Hypostomal area with few shallow punctures. Mesosoma: (13) Anterior third of scutum with dense medium-sized punctures; posterior two thirds of scutum shiny with punctures along parapsidal furrow and anteromedian line (not as dense as on anterior and posterior portions); dense punctures on posterior margin before scuto-scutellar sulcus; impunctate area between anteromedian line and parapsidal furrow triangular. (14) Lateral margin of scutum lined with two or more rows of medium-sized punctures. (15) Procoxa with rounded angle on outer side at base. (16) Mesepisternum with dense coarse punctures

laterally; punctures larger and less dense ventrally; less dense punctures posterolaterally near mesocoxal base. (17) Area around scrobe with small conspicuous impunctate area. (18) Propodeal triangle finely coriaceo-reticulate; lateral area of propodeum densely and finely punctate, without or at most with very small patch of dense hair anteriorly. Metasoma: (19)–(21) See male. *Maculations* (yellow except as noted): Prosoma: (22) Inverted-T marking on clypeus well-developed (sometimes with small incision on upper margin). (23) Labrum black. (24) Mandible black. (25, 26) Supraclypeal and frontal spots well-developed. (27) Marking on paraocular area widened from top to bottom (Figure 13). (28) Genal marking slightly narrowed downward, extending $2/3$ of eye length. (29) Base of antennal scape ferruginous yellow or reddish brown. Mesosoma: (30) Transverse marking on pronotum well connected to yellow spot on pronotal lobe. (31) Spot behind pronotal lobe absent or at most small and vague (Thai specimens with large conspicuous spot). (32) Scutum without longitudinal lines. (33) Axilla black. (34) Tegula reddish-brown translucent. (35) Scutellum with large marking occupying entire area except anterior part, small incision on anterior margin of marking. (36) Marking on metanotum absent or at most small and vague. (37) Protrochanter and mesotrochanter with faint yellow markings apically. (38) Apex of profemur with yellow band extending basad on inner side, extending about $3/4$ of femur length. (39) Marking present on outer side of protibia and mesotibia. (40) Metatibia with yellow marking at base and extending distad for entire length of tibia. (41) Tarsi reddish-brown to black (yellow in Thai and Laotian specimens). (42) Metabasitarsus yellow.

Metasoma: (43) Metasomal bands well developed and unbroken (or T3 band interrupted medially, sometimes also T4 band), except no band on T6; T1 band with wide marking enclosing two small black spots.

Male: As described for female except as follows: *Structure*: (1) Length 5.70–9.20 mm. Prosoma: (2) Clypeus smooth with shallow scattered punctures along margins and yellow marking area; few punctures in median area; longitudinal median carina vague (sometime absent). (3) Labrum with dense coarse punctures and few long setae. (5) Inner part of antennal fossa with medium-sized to coarse punctures along frontal carina (punctures not as well defined as in female), outer part impunctate or at most with few punctures. (7) Supraclypeal area below frontal carina with few shallow punctures, ventrally depressed. (8) Frons and vertex with dense and coarse punctures. Mesosoma: (13) Anterior third of scutum with dense medium-sized punctures; posterior two thirds of scutum shiny with punctures along parapsidal furrows and anteromedian line (not as dense as anterior and posterior portions, but denser than in female); dense punctures on posterior margin before scuto-scutellar sulcus; impunctate area between anteromedian line and parapsidal furrow more reduced than in female. (16) Mesepisternum with dense coarse punctures laterally; punctures larger and less dense ventrally; punctures posterolaterally near mesocoxal base denser than in female. Metasoma: (19) S6 with V-shaped ridge and small lateral tooth on subapical depression (Figure 143); anterior part of S6 with coarse and dense punctures and long stiff bristles (no bristles near ridge); apical lobe not prominent.

(20) T7 more or less pointed apically with conspicuous emargination and rounded edges. (21) Distal part of gonocoxite slightly narrowed, with bristles along apical margin; inner margin of gonocoxite rounded. *Maculations*: Prosoma: (22) Inverted-T marking on clypeus well-developed, occupying almost entire area except margin. (23) Labrum with marking. (24) Mandible black. (26) Frontal spot reduced, smaller than in female. (27) Marking on paraocular area extensive, widened from top to bottom (Figure 114). (29) Base of antennal scape ferruginous yellow to black (some specimens from Laos with yellow spot at apex). Mesosoma: (31) Spot behind pronotal lobe on mesepisternum absent or at most small and vague (some Thai specimens with distinct yellow spot). (38) Procoxa with yellow marking on outer side; apex of profemur with yellow band extending basad on inner side for entire length of femur. (41) Tarsi yellow (some specimens ferruginous or reddish brown). (42) Metabasitarsus yellow. Metasoma: (43) Metasomal band on T3 interrupted medially (sometimes T2 and/or T4 bands interrupted).

SPECIMENS EXAMINED IN ADDITION TO TYPES.—158 (107♀, 51♂).

INDONESIA. Java: Boyolali, 10 May 1973, 450 m., C.D. Michener (7♀, 5♂; **LAWRENCE**), 23 May 1973, 450 m., C.D. Michener (59♀, 26♂; **LAWRENCE**); 15 km. W. of Boyolali, 10 May 1973, 1,500 m., C.D. Michener (1♀, 2♂; **LAWRENCE**).

LAOS. Borikhane: Paksane, 28 September 1965, Native Collector (1♂;

HONOLULU), 20 December 1965, Native Collector (1♂; **HONOLULU**). Nongtevada:

25 August 1965, Native Collector (2♀; **HONOLULU**), 30 August 1965, Native Collector (1♀; **HONOLULU**), 18 September 1965, J.A. Rondon (1♂; **HONOLULU**), 27 September 1965, Native Collector (1♀, 1♂; **HONOLULU**), 22 December 1965, Native Collector (2♀; **HONOLULU**). Savannakhet: 15 September 1965, Native Collector (1♀; **HONOLULU**). Sayaboury: Sayaboury, 12 December 1965, Native Collector (1♀; **HONOLULU**). Vientiane: Ban Van Eue, October 1965, Native Collector (1♂; **HONOLULU**); Dong Dok, 3 November 1965, Native Collector (1♀; **HONOLULU**), 22 December 1965, Native Collector (1♀; **HONOLULU**); Tha Ngone, Gi Sion Village, 7–21 February 1965, Native Collector (2♂; **HONOLULU**), 23 September 1965, Native Collector (2♀, 1♂; **HONOLULU**), 29 September 1965, Native Collector (1♀; **HONOLULU**), 24–31 October 1965, Native Collector (1♂; **HONOLULU**), 11 November 1965, Native Collector (1♀; **HONOLULU**); Vientiane, 3 August 1965, Native collector (1♀; **HONOLULU**). Wapikhamthong: Wapi, 31 May 1967, Native Collector (1♀; **HONOLULU**). Sedone: K Sedone, 13 October 1965, Native Collector (1♀; **HONOLULU**); Pakse, 31 May 1967; Native Collector (1♀; **HONOLULU**); Paksong, 26 July 1965, Native Collector (1♀; **HONOLULU**).

MALAYSIA. Negeri Sembilan: Bahau, Tassek Bera, 17 October 1975, R. Jander (3♀; **LAWRENCE**). Penang: George Town, 4 June 1973, C.D. Michener (4♀, 3♂; **LAWRENCE**). Selangor: Ampang, E of Kuala Lumpur, 3 June 1973, C.D. Michener (1♀; **LAWRENCE**); near Kuala Lumpur, 30 September 1973, Phang Ong Wah (2♂; **LAWRENCE**). Kuala Lumpur, 3 June 1973, C.D. Michener (1♂; **LAWRENCE**).

THAILAND. Kanchanaburi: 110 air km. W. of Bangkok, 25–27 April 1988, W.J. Pulawski (1♀; **SAN FRANCISCO**). Loei: Wang Saphung, 18–19 April 1989, W.J. Pulawski (1♀; **SAN FRANCISCO**), 21 April 1989, W.J. Pulawski (1♀; **SAN FRANCISCO**), 24 April 1989, W.J. Pulawski (2♀; **SAN FRANCISCO**). Nakhon Nayok: Nakhon Nayok, 21 January 1993, S. Boongird and C.D. Michener (3♀; **LAWRENCE**). Nakhon Ratchasima: Burerum, 20 February 1993, 163 m., Jarunya Thummanu (1♀; **LAWRENCE**), 22 February 1993, 163 m., Jarunya Thummanu (1♀, 1♂; **LAWRENCE**), 3 March 1993, 163 m., Jarunya Thummanu (1♀, 1♂; **LAWRENCE**), 10 April 1993, 163 m., Jarunya Thummanu (1♂; **LAWRENCE**), 20 April 1993, 163 m., Jarunya Thummanu (2♀; **LAWRENCE**), 15 May 1993, Jarunya Thummanu (1♀; **LAWRENCE**).

Ceratina collusor Cockerell

FIGURE 14, 50, 84, 115, 144, 170 (see Figure section at the end of text)

Ceratina collusor Cockerell, 1919b: 248 [male]; Cockerell, 1920d: 227 [*C. collusor* var. *a.*, female and male]; van der Vecht, 1952: 75–77 [redescriptions of female and male].

TYPE MATERIAL.—The male holotype in the Natural History Museum, **LONDON**, is labeled “T.D.A. *Cockerell* B.M. 1936-415”, “1879b”, “Singapore Coll. Baker”, and “Type # 17 b 238”. The type is in good condition.

DISTRIBUTION.—*Ceratina collusor* is recorded from Burma, Thailand, Laos, Malaysia, Singapore, and Indonesia.

DIAGNOSIS AND COMPARATIVE COMMENTS.—Both sexes of *C. collusor* can be distinguished from other *Ceratinidia* in the compacta species-group by the absence of punctures along the parapsidal furrow and in the area between the furrow and the lateral margin of scutum, and the presence of a protuberance on the outer side of the procoxa. *Ceratina collusor* is similar to *C. nigrolateralis* in many aspects, but can be differentiated by the smaller size, the presence of yellow marking on the base of the scape (sometimes on the apex also), and the rectangular marking that occupies most of the scutellum.

Van der Vecht (1952) synonymized *C. incertula* under *C. collusor* without examining the type and concluded that it is a darker form of *C. collusor*. I examined the *C. incertula* type and found that it is a different species from *C. collusor*, as shown by the presence in *C. incertula* of punctures along parapsidal furrows and in the area between the furrows and the lateral margin of the scutum, and by the absence of a protuberance on the outer side of the procoxa.

DESCRIPTION—**Female:** *Structure:* (1) Length 5.80–8.00 mm. Prosoma: (2) Clypeus smooth with shallow scattered punctures; longitudinal median carina vague (sometimes absent). (3) Labrum with dense shallow punctures, and with many setae. (4) Paraocular area below antennal fossa with few shallow punctures. (5) Inner part of antennal fossa with coarse punctures along frontal carina, outer part impunctate or at most with few shallow punctures. (6) Dorsolateral margin of antennal fossa without smooth fovea. (7) Supraclypeal area below frontal carina impunctate. (8) Frons impunctate or with few strong punctures in lower part of antennal fossa area, but with scattered coarse punctures in upper part, and throughout vertex (less than in *C. nigrolateralis*). (9) Space between ocelli and upper part of compound eye with very few medium-sized punctures. (10) Genal area with few shallow punctures. (11) Preoccipital carina not prominent; area behind ocelli slightly depressed. (12) Hypostomal area smooth with few small punctures. Mesosoma: (13) Anterior third of scutum with dense medium-sized punctures; posterior two thirds of scutum shiny with few or no punctures along parapsidal furrows and anteromedian line, but with dense punctures on posterior marginal area near scuto-scutellar sulcus. (14) Lateral edge of scutum lined with single row of medium-sized punctures. (15) Procoxa angularly produced on outer side at base. (16) Mesepisternum with dense coarse punctures; punctures scattered ventrally and especially on posterolateral area near mesocoxal base. (17) Area around scrobe with conspicuous impunctate area. (18) Propodeal triangle finely coriaceo-reticulate; lateral area of propodeum densely and finely punctate; without small patch of dense hair anteriorly. Metasoma: (19)–(21)

See male. *Maculations* (yellow except as noted): Prosoma: (22) Inverted-T marking on clypeus well-developed almost attaining frontoclypeal sulcus, with small hook-like point downward on lateral arm. (23) Labrum with yellow spot. (24) Mandible black. (26, 27) Supraclypeal and frontal spots well-developed. (27) Marking on paraocular area widened from top to bottom (Figure 14). (28) Genal marking slightly narrowed downward, extending half to 2/3 of eye length. (29) Base of antennal scape often yellow or ferruginous, showing abrupt color change; sometimes apex with yellow or ferruginous spot. Mesosoma: (30) Transverse marking on pronotum well connected to yellow spot on pronotal lobe. (31) Spot behind pronotal lobe present (size varies). (32) Scutum with four longitudinal lines. (33) Axilla with small vague yellow spot (sometimes absent in specimens with ferruginous scape). (34) Tegula reddish-brown translucent. (35) Scutellum with large marking occupying entire area except anterior part; small incision on anterior margin of marking. (36) Marking on metanotum absent (some specimens with small spot). (37) Protrochanter and mesotrochanter usually without yellow marking at apices. (38) Apex of profemur with yellow band extending basad on inner side, occupying 2/3 of femoral length. (39) Markings present on outer sides of protibia and mesotibia, extending toward entire lengths of tibiae. (40) Metatibia with yellow marking at base extending distad for 1/4 of tibial length. (41) Tarsi yellow ferruginous. (42) Metabasitarsus ferruginous to dark brown. Metasoma: (43) Metasomal bands well developed and unbroken (T3 band interrupted), except no band on T6; T1 with wide marking enclosing two small black spots.

Male: As described for female except as follows: *Structure:* (1) Length 5.70–8.45 mm. Prosoma: (7) Supraclypeal area slightly depressed in lower part. (10) Genal area with scattered coarse punctures (specimens from Thailand as in female). Mesosoma: (15) Procoxa angularly produced on outer side at base (more blunt than *C. nigrolateralis*, except specimens from Thailand). Metasoma: (19) S6 with V-shaped ridge with small lateral tooth on each side of ridge on subapical depression (Figure 144); anterior part of S6 with coarse and dense punctures and stiff long bristles (no bristles near ridge); apical lobe not prominent. (20) T7 apically pointed and edges slightly round. (21) Distal part of gonocoxite of genitalia slightly narrowed, with two tufts of bristles on apical margin; inner margin of gonocoxite rounded. *Maculations:* Prosoma: (22) Inverted-T marking on clypeus well-developed, occupying almost entire area. (23) Two large black lateral spots and one median spot on labrum enclosed by yellow maculation (not in Java specimens). (24) Triangular spot on base of mandible (absent in Java specimens). (26, 27) Supraclypeal and frontal spots well-developed. (27) Marking on paraocular area widened from top to bottom (Figure 115). (28) Genal marking slightly narrowed downward, extending $\frac{1}{4}$ to half of the eye length. (29) Base of antennal scape yellow or ferruginous (more extensive than female), color change (black to yellow or ferruginous abrupt); apex sometimes with yellow or ferruginous spot. Mesosoma: (31) Spot in front of pronotal lobe present (sometimes absent); mesepisternum with yellow markings below hypopimeral area and on ventral side (Phuket specimens,

Thailand). (33) Axilla black (specimens from Thailand as in female). Metanotum with small yellow spot (specimens from Phuket, Thailand, as in female). (40)

Metatibia with yellow marking at base and extending distad $\frac{1}{2}$ to entire length of tibia. (41) Protarsus yellow; mesotarsus and metatarsus yellow ferruginous.

Metasoma: (43) Metasomal bands less well developed than female; T3 band usually interrupted medially; T7 band absent.

SPECIMENS EXAMINED IN ADDITION TO TYPES.—18 (11♀, 7♂).

BURMA. Mandalay (U. Burma): 7 October 1898, P. Herbst Collection Ex Reed (1♀;

SAN FRANCISCO). Maymyo: 2 September 1898, Bingham (1♀; **BERLIN**)

INDONESIA. Java: Bogor, 15 May 1973, C.D. Michener (2♀, 1♂; **LAWRENCE**);

Botanical Garden, 17 November 1960, H. Hamann (1♂; **HONOLULU**)

LAOS. Sayaboury: 13 April 1966, Native Collector (1♂; **HONOLULU**). Vientiane:

Ban Van Eue, 31 July 1965, Native Collector (2♀; **HONOLULU**); Tha Ngone, 21

August 1965, Native Collector (1♂; **HONOLULU**). Wapikhamthong: Wapi, 15 March

1967, Native Collector (1♂; **HONOLULU**)

MALAYSIA. Penang: 22–26 December 1958, L.W. Quate (1♂; **HONOLULU**).

Selangor: Ampang, E. of Kuala Lumpur, 3 June 1973, C.D. Michener (1♀, 1♂;

LAWRENCE); Kuala Lumpur, (British Malaya), 14 November 1920, No Collector's Name (1♀; **NEW YORK**); Ulu Gombak, 21 June 1970, James E. Tobler (3♀; CAS)

SINGAPORE. Kent Ridge Park: 14 October 1986, John W. Wenzel (1♀;

LAWRENCE). MacRitchie Nature Reserve: 16 December 1998, 1 21'N 103 50'E,

Liow L-H and Ong L. (1♀; **LAWRENCE**), 25 February 1999, Liow Lee Hsiang (1♂;

LAWRENCE), 13 April 1999, Liow Lee Hsiang (1♀; **LAWRENCE**)

THAILAND. Chiang Mai: Mae Rim, 27 January 1994, R.A. Beaver (1♀; **LOS**

ANGELES). Phuket: 29 January 1993, S. Boongird and C.D. Michener (1♀;

LAWRENCE). Nakhonsri Thammarat: Thasala, 24 June 2001, 8 46'N 99 55'E, N.

Warrit (1♂; **LAWRENCE**)

Ceratina compacta Smith

FIGURE 15, 51, 85, 116, 145, 171 (see Figure section at the end of text)

Ceratina hieroglyphica Smith, 1854: 226 [female and male description, part (Philippine specimen)].

Ceratina compacta Smith, 1879: 91 [male; erroneously described as female]; van der Vecht, 1952: 66–69 [recognized *C. philippinensis* = *C. compacta*; redescription of female and male]; ? Wu, 2000: 172 [record from China;

however, only one specimen]; Warrit, 2007: 72–77 [probably adventive in Thailand].

Ceratina philippinensis Ashmead, 1904: 2 [Female]; Cockerell, 1915: 109 [new record in Negros, Philippines]; Cockerell, 1916: 304 [suspected *C. philippinensis* = *C. compacta*]; Cockerell, 1918: 142 [new records in Mindanao and Palawan, Philippines]; Cockerell, 1920a: 146 [new record in Culasi and Batbatan Island, Philippines]; Cockerell, 1920b: 207; Cockerell, 1925a: 54 [new record in Bangui, Ilocos Norte, Philippines]; Cockerell, 1925b: 172 [new record on Samar Island, Philippines]; Hedicke, 1926: 419.

TYPE MATERIAL.—The male type of *C. compacta* in the Natural History Museum, **LONDON**, is labeled “Phil. Isla.” and “Type # 17 b 214”. This type was first described under the name *C. hieroglyphica* Smith along with other material from Northern India and Hong Kong. Smith (1879) later recognized that the type from the Philippines was not a conspecific to the types from the two latter locations, and named the type from the Philippines *C. compacta*. I designate as lectotype the male type of *C. compacta* in **LONDON**, and add a red label “*Ceratina compacta* Smith, Lectotype, N. Warrit, 2007”.

The female holotype of *C. philippinensis* in the United States National Museum of Natural History, The Smithsonian’s Institution, **WASHINGTON, D.C.**, is labeled “Manila PI”, “Type No 7692 U.S.N.M.”, and “W. A. Stanton Collector”. According to van der Vecht (1952), *C. compacta* has long been recognized as *C.*

philippinensis. This is partly due to the fact that the type of *C. compacta* was first erroneously described as female, instead of male, by Smith (1879). Cockerell (1916) suspected that the female of *C. philippinensis* was possibly a female *C. compacta*; later in the same paper he made a note about it. Van der Vecht (1952) examined the types of both *C. philippinensis* and *C. compacta* and verified that *C. philippinensis* is in fact the female of *C. compacta*. I have seen both type specimens and agree with van der Vecht's finding.

As noted in the account of *C. incertula* Cockerell, this name is a possible synonym of *C. compacta*, and would be a name for the Thailand populations of this species if needed.

DISTRIBUTION.—In previous literatures, *Ceratina compacta* is recorded only from the Philippine Islands. Examination of specimens from Thailand and one from northern Sulawesi indicate its presence outside the Philippines. The specimens from Thailand may have been introduced into that area; for evidence sees Warrit (2007).

DIAGNOSIS AND COMPARATIVE COMMENTS.—The male of *C. compacta* has a V-shape ridge on the subapical depression of S6 instead of long lateral teeth as in the *bryanti* and *flavipes* species-groups. Both sexes of *C. compacta* can be distinguished from other *Ceratinidia* in the *compacta* species-group by this combination of characters: (1) lateral area of scutum with one or usually two or more complete rows of punctures along the parapsidal furrow; area between lateral margin of scutum and

parapsidal furrow densely or partially punctate (2) scutum with four yellow longitudinal lines (3) base of antennal scape yellow.

DESCRIPTION—**Female:** *Structure:* (1) Length 5.90–8.80 mm. Prosoma: (2) Clypeus slightly wrinkled with shallow scattered punctures along upper margin; few punctures on lower part (specimens from Samar Island with smooth clypeus and fewer punctures; some specimens from Thailand with punctures on lower part). (3) Labrum with dense coarse punctures, and with many long stiff bristle. (4) Paraocular area below antennal fossa superficially wrinkled with shallow fine and medium-sized scattered punctures. (5) Inner part of antennal fossa with medium-sized to coarse punctures along frontal carina; outer part impunctate or at most with few punctures. (6) Dorsolateral area of antennal fossa without or at most with small conspicuous smooth fovea. (7) Supraclypeal area below frontal carina impunctate with ventral depression. (8) Frons with few strong punctures in lower part of antennal fossa area, but with dense and coarse punctures in upper part, and throughout vertex. (9) Space between ocelli and upper part of compound eye with few well-defined punctures (specimens from Thailand almost impunctate). (10) Gena shiny with many shallow scattered punctures. (11) Preoccipital carina not prominent; area behind ocelli slightly depressed. (12) Hypostoma with shallow scattered punctures (some specimens impunctate on lower part; specimens from Samar Island almost impunctate). Mesosoma: (13) Scutum densely punctured throughout, except impunctate area between anteromedian line and parapsidal furrow (some specimens

with impunctate area between parapsidal furrow and lateral margin of scutum); anterior and posterior areas with dense medium-sized punctures; less dense punctures in middle area (Thai specimens with more punctures than specimens from the Philippines). (14) Lateral margin of scutum lined with two or more rows of medium-sized punctures. (15) Procoxa with round angle on outer side at base. (16) Mesepisternum with very dense coarse punctures laterally and posterolaterally near mesocoxal base; punctures much less dense ventrally. (17) Area around scrobe with conspicuous impunctate area. (18) Propodeal triangle finely coriaceo-reticulate; lateral area of propodeum densely and finely punctate, without or with very small patch of dense hair anteriorly. Metasoma: (19)–(21) See male. *Maculations* (yellow except as noted): Prosoma: (22) Inverted-T marking on clypeus well-developed; some specimens with small incision on apex of upper lobe. (23) Labrum with yellow marking (sometime vague; absent in Thai specimens). (24) Mandible black. (26, 27) Supraclypeal and frontal spot well-developed; frontal spot large (sometimes linear). (27) Marking on paraocular area widen from top to bottom (Figure 15). (28) Genal marking slightly narrowed downward; extending 2/3 of eye length. (29) Base of antennal scape yellow. Mesosoma: (30) Transverse marking on pronotum well connected to yellow spot on pronotal lobe. (31) Spot behind pronotal lobe large. (32) Scutum with four longitudinal lines. (33) Axilla black. (34) Tegula reddish-brown translucent. (35) Scutellum with large marking occupying the entire area except anterior part; small incision on anterior margin of marking. (36) Marking on metanotum absent (some with small vague yellow marking). (37) Protochanter and

mesotrochanter usually with faint yellow marking apically or absent. (38) Apex of profemur with yellow band extending basad on inner side for almost entire of length of femur. (39) Protibia and mesotibia with distal marking on outer and inner sides. (40) Metatibia with yellow marking at base extending distad for almost entire length of tibia (specimens from Samar Island only two thirds). (41) Tarsi ferruginous yellow. (42) Metabasitarsus yellow. Metasoma: (43) Metasomal bands well developed and usually unbroken (T3 band slightly interrupted medially, sometimes also T2 and/or T4 bands), T6 without band; T1 with wide marking enclosed two small black spots.

Male: As described for female except as follows: *Structure*: (1) Length 6.05–7.80 mm. Prosoma: (2) Clypeus slightly wrinkled with shallow scattered punctures along entire margin; more or less impunctate on median area (Luzon specimens with more puncture). (3) Labrum with some coarse punctures and long stiff bristles (not as many as in female). (4) Paraocular area below antennal fossa superficially wrinkled with shallow, more or less dense, medium-sized scattered punctures (denser than in female); small conspicuous invagination above antennal fossa area (more apparent than in female). (7) Supraclypeal area below frontal carina with few coarse punctures or impunctate, with ventral depression. (9) Space between ocelli and upper part of compound eye with few well-defined punctures. (10) Gena shiny with more shallow scattered punctures than in female. (12) Hypostoma with shallow scattered punctures, except impunctate on lower part. Mesosoma: (13) Anterior part of scutum

with more punctures than in females. (16) Mesepisternum with dense coarse punctures laterally; punctures much less dense ventrally and posterolaterally near mesocoxal base. (17) Area around scrobe with small conspicuous impunctate area. (18) Propodeal triangle finely coriaceous-reticulate; lateral area densely and finely punctate, with very small patch of dense hair anteriorly. Metasoma: (19) S6 with V-shaped ridge on subapical depression (Figure 145); anterior part of S6 with coarse and dense punctures and long stiff bristles (no bristles near ridge); apical lobe not prominent. (20) T7 more or less pointed apically with conspicuous emargination and rounded edges. (21) Distal part of gonocoxite slightly narrowed, with bristles along apical margin; inner margin of gonocoxite rounded. Maculations: Prosoma: (22) Inverted-T marking on clypeus well-developed occupying almost entire area except margin. (24) Mandibles with yellow spot on some Thai specimens. (26, 27) Supraclypeal and frontal spots well-developed; frontal spot somewhat linear (smaller than in female). (27) Marking on paraocular area occupying almost entire area except margin (Figure 116). (29) Base of antennal scape yellow (sometimes apex of scape with vague spot [large in Thai specimens]). Mesosoma: (31) Spot behind pronotal lobe absent in some Thai specimens. Metasoma: (43) Metasomal bands well developed and unbroken (T3 band sometimes slightly interrupted medially, sometimes T2 and/or T4 bands likewise), except no band on T7; T1 with wide marking enclosed two small black spots.

SPECIMENS EXAMINED.—88 (80♀, 8♂).

INDONESIA. Sulawesi: N. Celebes, Tondano, 30 May 1940, R.G. Wind (1♀; **SAN FRANCISCO**).

PHILIPPINES. Basilan: no collecting date, Baker (1♀; **LOS ANGELES**). Leyte: Tacloban, December 1944, E.S. Ross (1♀; **SAN FRANCISCO**). Libon: Albay Province, Cagascos, 13 May 1965, 200m., H.M. Torrevillas (1♀; **LONDON**). Luzon: Ifugao, Mayayao, Mountain Province, 9 July 1966, 1,200–1,500 m., H.M. Torrevillas (2♂; **LONDON**), 12 July 1966, 1,200–1,500 m., H.M. Torrevillas (1♀; **LONDON**), 17–18 August 1966, 1,200–1,500 m., H.M. Torrevillas (1♂; **LONDON**), 2 September 1966, 1,200–1,500 m., H.M. Torrevillas (1♂; **LONDON**); 24 km. E. of Mayoyao, Jacmal Buphian, 25–26 April 1967, 800–1,000m, L.M. Torrevillas (1♀; **LONDON**); Manila, June 1924, no collector's name (5♀; **NEW YORK**), 1913, D. T. Fullaway (1♀; **LONDON**), 27 August 1945, J.L. Gressitt (1♀; **LONDON**); Los Banos, 1913, Ledyard (1♀; **SAN FRANCISCO**); Grande Island, Subic Bay, 7 October–15 November 1967, C.E. Goodpasture (2♀; **LOS ANGELES**); Mt. Montalban, Rizal Wa-wa Dam, 1 March 1965, 150–200 m., H.M. Torrevillas (1♀; **LONDON**). Mindanao: Misamis Oriental, 3.2 km. S. of Gingoog City, 15 May 1961, 50m., L. Torrevillas (2♂; **LONDON**), Mt. Pomalihi 21 km. W. of Gingoog City, 16–18 October 1965, 800–1,000 m., H.M. Torrevillas (1♂, **LONDON**), Mt. Pomalihi 21 km. W. of Gingoog City, 26–28 October 1965, 800–1,000 m., H.M. Torrevillas (1♂, **LONDON**), Pigtibiran, 1–13 May 1961, 600 m, W. Torrevillas (1♀; **LONDON**); Davao city, Bago Oshiro, 9–11 April 1992, S.G. Reyes (39♀, **LAWRENCE**); Surigao, no collecting date,

Baker (1♀; **LOS ANGELES**). Mindoro: San José, 5 June 1945, Ross and Skinner (1♀; **SAN FRANCISCO**), April 1945, F.E. Skinner (2♀; **LOS ANGELES**), May 1945, F.E. Skinner (8♀; **LOS ANGELES**), October 1945, F.E. Skinner (7♀; **LOS ANGELES**). Palawan: Aborlan, Isla Sombrero, 20 February 1987, C.K. Starr (1♀; **LOS ANGELES**). Panay: Culasi, June 1918, M. Gregor (2♀; **LAWRENCE**). Samar: Naval base, April 1945, G.E. Bohart (1♀; **SAN FRANCISCO**).

THAILAND. Bangkok: Kampengsan district, 10 December 2002, P. Angmani (1♀; **LAWRENCE**). Chiang Mai: Mae Rim 18° 08'N 98° 97'E, 13 July 1996, R.R. Snelling (1♀; **LOS ANGELES**); Meuang District; Mae Hei Research Station 18° 45'N, 98° 56'E, 9 June 2003, 500 m., N. Warrit (5♀; **LAWRENCE**). Kanchanaburi: 100 air km W of Bangkok, 25–27 April 1988, W.J. Pulawski (1♂; **SAN FRANCISCO**). Loei: Wang Saphung District, 20 April 1989, W.J. Pulawski (1♀; **SAN FRANCISCO**), 23 April 1989, W.J. Pulawski (1♀; **SAN FRANCISCO**). Nakorn Nayok: 21 January 1993, S. Boongird and C. Michener (1♀; **LAWRENCE**). Phitsanulok: Bangraka District; Naresuan University 16° 44'N 100° 11'E, 17 June 2003, N. Warrit (1♀; **LAWRENCE**).

Ceratina coptica Baker

FIGURE 52 and 86 (see Figure section at the end of text)

Ceratina coptica Baker, 2002a: 367, fig. 10 [female]

TYPE MATERIAL.—The female holotype of *C. coptica* in the Hope Entomological Collection, Oxford University, **OXFORD**, is labeled “India Sidapur 1988”, “assoc with coffee CIE A20185”. Three paratypes (all **LAWRENCE-BAKER**) were examined, two from same locality as the holotypes, one from Kashmir turned out to be *C. lepida*, based on the facial punctation pattern (even though the punctures are shallow) and the sparsely punctate anterior portion of the scutum. Baker (2002a) recognized four specimens (one holotype, two paratypes, and one other paratype, but misidentified). No male or other females of *C. coptica* have been found.

DISTRIBUTION.—*Ceratina coptica* is known only from Sidapur (Karnataka state) of India.

DIAGNOSIS AND COMPARATIVE COMMENTS.—*Ceratina coptica* is superficially similar to *C. simillima* but lacks the punctures on the area between parapsidal furrow and lateral margin of scutum, and punctures on the frons and vertex are sparse. The status of *C. coptica* is questionable since many characters (structural and maculation), agree well with those of *C. simillima* except as mentioned above. *Ceratina coptica* might be another morph of *C. simillima* that has less punctation on the scutum, frons, and vertex. Only the three original specimens were examined. Until the male and more female specimens are available, I treat *C. coptica* as a species separate from *C. simillima*.

Baker (2002a) suggested that *C. coptica* is also similar to *C. bowringi* (synonym of *C. taiwanensis*), but it differs by the character of the scutum mentioned above and by the maculation pattern.

DESCRIPTION—**Female:** *Structure:* (1) Length 7.30–7.80 mm. Prosoma: (2) Clypeus with median longitudinal impressed area; lateral part of impressed area with slightly dense small to medium-sized punctures; lower part slightly rugose or smooth with sparse small to medium-sized punctures. (3) Labrum with mixture of medium-sized and coarse punctures, and many bristles. (4) Paraocular area below antennal fossa with rather dense, shallow, medium-sized punctures, mostly on median part, few punctures on upper and lower parts of paraocular area. (5) Inner part of antennal fossa with dense coarse punctures along frontal carina, outer part impunctate. (6) Dorsolateral area of antennal fossa area without smooth fovea. (7) Supraclypeal area below frontal carina with few scattered punctures. (8) Frons and vertex with dense and coarse punctures (not as dense as in *C. simillima*). (9) Space between ocelli and upper part of compound eye with scattered coarse punctures. (10) Gena shiny, almost impunctate, with few punctures on lower part. (11) Preoccipital carina prominent. (12) Hypostomal area with few medium-sized punctures; hypostomal carina slightly prominent. Mesosoma: (13) Anterior portion of scutum with dense medium-sized punctures; no or with few punctures laterally along parapsidal furrow; posterior part of scutum densely punctate; large area between anterior and posterior parts impunctate. (14) Lateral margin of scutum lined with one or two rows of medium-

sized punctures. (15) Procoxa with rounded angle on outer side at base. (16) Mesepisternum with dense coarse punctures laterally and ventrally; punctures slightly less dense posterolaterally near mesocoxal base. (17) Area around scrobe with conspicuous impunctate area. (18) Propodeal triangle coriaceous-reticulate; lateral area of propodeum densely and finely punctate, without patch of dense hair anteriorly.

Metasoma: (19)–(21) Unknown. *Maculations* (yellow except as noted): Prosoma: (22) Upper lobe of inverted-T marking on clypeus at most reaching 2/3 of clypeal length; lateral arms of marking usually with small hook-like projection pointing downward. (23) Labrum black. (24) Mandible black. (25) Supraclypeal spot well-developed. (26) Frontal spot well-developed. (27) Marking on paraocular area linear and curving inward along lower margin (hook-like). (28) Genal marking slightly narrowed downward, extending 2/3 of eye length. (29) Base of antennal scape black.

Mesosoma: (30) Transverse marking on pronotum not interrupted medially, connected to yellow spot on pronotal lobe. (31) Spot behind pronotal lobe absent. (32) Scutum with four longitudinal lines. (33) Axilla black. (34) Tegula reddish-brown translucent. (35) Scutellum with marking rectangular; small incision on anterior margin of marking. (36) Marking on metanotum absent. (37) Protrochanter and mesotrochanter with small marking apically. (38) Profemur black with yellow spot on outer and inner side. (39) Protibia dark brown to black with yellow marking on outer side extending distally from base for half tibial length; mesotibia with yellow spot at base. (40) Metatibia black with yellow spot at base. (41) Tarsi dark brown to black. (42) Metabasitarsus dark brown to black. Metasoma: (43) Metasomal bands

reduced; T1 with remnant of band not enclosing black spots, T2–T4 with bands usually interrupted medially, no band on T6.

Male: Unknown

***Ceratina demotica* Baker**

FIGURE 16, 53, 87 (see Figure section at the end of text)

Ceratina demotica Baker, 2002a: 366–367, fig. 9 [female].

TYPE MATERIAL.— The female holotype in the Natural History Museum, **LONDON**, is labeled “Simla / 8.98”, “Col. C. G. Nurse Collection”, “B.M. Type Hym. 3140”, and “Holotype ♀ *Ceratina demotica* Baker 1982”. The type locality of *C. demotica* is Simla, Himalchal Pradesh, India. Baker recognized this species in 1982, but did not publish the name until 2002.

DISTRIBUTION.—*Ceratina demotica* is known from Northern India (e.g., Himalchal Pradesh and Uttar Pradesh).

DIAGNOSIS AND COMPARATIVE COMMENTS.—*Ceratina demotica* is similar to *C. moderata* in the presence of punctures on the outer side of the antennal fossa (more or less extensive), extending to the dorsolateral area between the antennal fossa and

compound eye; and in the sparsely punctate mesepisternum. *Ceratina demotica*; however, can be distinguished from *C. moderata* by the more extensive maculation on the body, especially facial and mesosomal markings.

I am uncertain about the specific status of *C. demotica* because of its resemblance to *C. moderata*, except for the maculation. Genitalic structure and terminal segments of male *C. demotica*, when known, will help determine its status.

DESCRIPTION—**Female:** *Structure:* (1) Length 7.45–10.07 mm. Prosoma: (2) Clypeus slightly smooth with small scattered punctures along margin, mostly on dorsal and dorsolateral area; median part of clypeus almost impunctate; median longitudinal impressed area sometimes present. (3) Labrum with scattered coarse punctures and several long bristles. (4) Paraocular area below antennal fossa shiny and smooth, usually almost impunctate with few scattered small punctures (sometimes with scattered well-defined punctures). (5) Inner part of antennal fossa with slightly dense medium-sized punctures along frontal carina, outer part with clumps of small punctures and hairs mostly on dorsolateral area near compound eye. (6) Dorsolateral area of antennal fossa area without smooth fovea; with clumps of small to medium-sized punctures and setae (less dense than in *C. moderata*). (7) Supraclypeal area below frontal carina impunctate. (8) Frons with scattered medium-sized punctures, vertex with more dense and coarse punctures. (9) Space between ocelli and upper part of compound eye with 1–2 coarse punctures. (10) Gena shiny, almost impunctate. (11) Preoccipital carina somewhat prominent; area behind ocelli

nearly flat. (12) Hypostomal area impunctate; hypostomal carina slightly prominent. Mesosoma: (13) Anterior third of scutum with sparse small to medium-sized punctures; posterior two thirds of scutum impunctate except posterior part with dense puncture. (14) Lateral margin of scutum lined with one or two rows of small fine punctures. (15) Procoxa with round angle on outer side at base. (16) Mesepisternum sparsely punctate laterally and ventrally; punctures more or less sparse posterolaterally near mesocoxal base; large impunctate area on hypoepimeral area. (17) Area around scrobe with large conspicuous impunctate area. (18) Propodeal triangle finely coriaceo-reticulate; lateral area of propodeum densely and finely punctate, with patch of dense hair in anterior part. Metasoma: (19)–(21) Unknown. *Maculations* (yellow except as noted): Prosoma: (22) Marking on clypeus well-developed; upper lobe of inverted-T marking almost reaching frontoclypeal sulcus. (23) Labrum usually with small marking. (24) Mandible usually ferruginous or yellow medially. (25) Supraclypeal spot well-developed. (26) Frontal spot well-developed. (27) Marking on paraocular area well-developed, lower end hook-like (Figure 16). (28) Genal marking extending half of eye length. (29) Base of antennal scape black. Mesosoma: (30) Transverse marking on pronotum almost connected to yellow spot on pronotal lobe. (31) Spot behind pronotal lobe absent. (32) Scutum without longitudinal lines. (33) Axilla black. (34) Tegula reddish-brown translucent. (35) Scutellum with triangular marking. (36) Marking on metanotum absent. (37) Protochanter and mesotrochanter with small marks on outer sides apically. (38) Profemur with yellow spots at apex, extending distad on inner side for half of femoral

length. (39) Protibia and mesotibia with yellow marking on outer side extending distally from base for entire length of tibia. (40) Metatibia with yellow spot at base, extending for half of tibial length. (41) Tarsi ferruginous. (42) Metabasis ferruginous. Metasoma: (43) Metasomal bands well developed and unbroken; T1 with wide marking enclosing two black spots, no band on T6.

Male: Unknown

SPECIMENS EXAMINED IN ADDITION TO TYPES.—3♀.

INDIA. Himalayas: Kumaon, Naini Tal [Uttar Pradesh: Naini Tal], 9 May 1964, F. L. Wain (1♀; **LAWRENCE-BAKER**). Himalchal Pradesh: Simla, 16 April 1965, no collector's name (1♀; **LAWRENCE**), no collection date, Col. C. G. Nurse Collection, no collector's name (1♀; **LAWRENCE-BAKER**).

Ceratina flavipes Smith

FIGURE 17, 54, 88, 117, 146, 172 (see Figure section at the end of text)

Ceratina flavipes Smith, 1879: 93; Shiokawa, 1963: 276 [redescription of female and male]; Yasumatsu and Hirashima, 1969: 66, 68 [mentioned in key]; Shiokawa and Hirashima, 1982: 183–184 [mentioned in key]; ? Wu, 2000: 173–174 [record in China]; Lee, 2005: 137–146 [record from Korea].

TYPE MATERIAL.—The male type in the Natural History Museum, **LONDON**, is labeled “B. M. TYPE HYM.17 B. 211.”, “*Ceratina flavipes* Type Sm.”, and “66 15 Japan”. The type is in fair condition, except missing its metasoma and one of its hindlegs is broken off. I designate as lectotype the type in **LONDON**, and add a red label “*Ceratina flavipes* Smith, Lectotype, N. Warrit, 2007”.

DISTRIBUTION.—*Ceratina flavipes* is recorded from Japan (except the Ryukyu Islands), the Korean Peninsula, the Primorskyi province of Russia, and possibly east China.

DIAGNOSIS AND COMPARATIVE COMMENTS.—*Ceratina flavipes* is similar to *C. japonica*. The diagnostic differences between these two species are discussed in the diagnosis section of *C. japonica*. The population from the Korean peninsular sometimes has four vague longitudinal lines on the scutum, whereas the Japanese and Russian populations usually have the scutum entirely black.

DESCRIPTION—**Female:** *Structure:* (1) Length 7.30–8.70 mm. Prosoma: (2) Clypeus rugose; small to coarse punctures along margin and median area, mostly on upper, upper lateral, and lower parts; median impressed area and median longitudinal carina strongly conspicuous. (3) Labrum with dense small and medium-sized punctures, and with some bristles. (4) Paraocular area below antennal fossa shiny (sometimes rugose) with few scattered small to medium-sized punctures. (5) Inner part of

antennal fossa with sparse, medium-sized punctures along frontal carina, outer part with scattered punctures. (6) Dorsolateral area above antennal fossa without small smooth fovea. (7) Supraclypeal area below frontal carina with 1–2 punctures. (8) Frons with scattered coarse punctures (some specimens with clumped of punctures); vertex with fairly dense coarse punctures. (9) Space between ocelli and upper part of compound eye almost impunctate, at most with few punctures. (10) Genal area shiny almost impunctate. (11) Preoccipital carina not prominent; area behind ocelli slightly depressed. (12) Hypostomal area almost impunctate and depressed. Mesosoma: (13) Anterior fourth to third of scutum fairly dense punctated with small punctures; posterior two thirds to three fourths densely punctured; along anteromedian line with at least one row of punctures; few or row of punctures along parapsidal furrow. (14) Lateral margin of scutum lined with at most one row of small punctures. (15) Procoxa with round angle on outer side at base. (16) Mesepisternum with scattered medium-sized punctures laterally (some specimens with few punctures) and less dense posterolaterally near mesocoxal base, ventral side with dense fine puncture; large impunctate area on hypoepimeral area; mesepisternum with dense long bristles. (17) Area around scrobe with large conspicuous impunctate area. (18) Propodeal triangle finely coriaceous-reticulate; lateral area of propodeum densely and finely punctate, without patch of dense hair anteriorly. Metasoma: (19)–(21) See male. *Maculations* (yellow except as noted): Prosoma: (22) Upper lobe of inverted-T marking on clypeus absent; remainder usually divided medially (some specimens without marking). (23) Labrum black. (24) Mandible black. (25) Supraclypeal spot

well-developed, but narrower than in *C. japonica*. (26) Frontal spot near frontal carina small and linear. (27) Marking on paraocular area linear, curved inward on lower part (hook-like); marking often interrupted medially and the rest of marking smaller than in *C. japonica* (Figure 17). (28) Genal marking streak-like; short. (29) Base of antennal scape black. Mesosoma: (30) Transverse marking on pronotum often reduced to only small lateral spot or absent, not connected to yellow spot on pronotal lobe (sometimes absent). (31) Spot behind pronotal lobe absent. (32) Scutum usually without yellow longitudinal lines (sometimes with two or four vague inner and/or outer lines; population from Korea has four lines). (33) Axilla black. (34) Tegula often reddish brown. (35) Scutellum often without marking or with small median spot, sometimes with triangular marking. (36) Marking on metanotum absent. (37) Protrochanter and mesotrochanter usually without markings apically, but sometimes markings present but vague. (38) Profemur dark brown, often with small yellow spot at apex. (39) Protibia and mesotibia ferruginous with yellow markings on outer sides extending for half of tibial lengths. (40) Metatibia dark brown often with small yellow spot at base. (41) Tarsi dark brown. (42) Metabasitarsus dark brown. Metasoma: (43) Metasomal bands more reduced than in *C. japonica*; T1 band not enclosing small spot (sometimes absent), T2 and T3 bands interrupted medially (sometimes broadly interrupted), T4 and T5 bands unbroken, no band on T6.

Male: As described for female except as follows: *Structure*: (1) Length 6.60–7.20 mm. Prosoma: (2) Clypeus smooth, superficially rugose with few small punctures;

median longitudinal carina present (less prominent than in female). (3) Labrum smooth with few scattered small punctures. (4) Paraocular area below antennal fossa smooth with scattered shallow small punctures. (5) Inner part of antennal fossa almost impunctate with few medium-sized punctures along frontal carina, outer part impunctate. (7) Supraclypeal area below frontal carina impunctate. (8) Frons with small clump of coarse punctures next to frontal carina and scattered long bristles; vertex with fairly dense coarse punctures and scattered long bristles. (10) Genal area shiny with few punctures. (12) Hypostomal area almost impunctate. Metasoma: (19) S6 with long submedian tooth (three times longer than wide) on subapical depression (Figure 146); anterior part of S6 with medium-sized and dense punctures and stiff long bristles (no bristle near teeth area); apical lobe prominent. (20) T7 apically pointed; lateral angle of T7 rounded inward. (21) Gonocoxite of genitalia broad at apex, with bristles along apical margin; inner margin of gonocoxite rounded.

Maculations (yellow except as noted): Prosoma: (22) Inverted-T marking on clypeus well-developed, occupying almost entire area except margin. (23) Labrum with large yellow marking. (24) Mandible black with yellow marking apically, sometimes basally. (25) Supraclypeal spot well-developed. (26) Frontal spot near frontal carina absent. (27) Marking on paraocular area well-developed, occupying almost entire area except margins (Figure 117). (28) Genal marking highly reduced to small spot; sometimes absent. (29) Base and apex of antennal scape yellow. Mesosoma: (30) Transverse marking on pronotum absent; yellow spot on pronotal lobe vague (sometimes absent). (32) Scutum without yellow longitudinal lines. (35) Scutellum

marking often absent. (38) Profemur dark brown usually with yellow spot at apex, extending for entire length of tibia (sometimes without marking). (39) Protibia and mesotibia ferruginous with yellow markings on outer sides extending for entire lengths of tibiae. (40) Metatibia yellow. (41) Tarsi ferruginous to yellow. (42) Meso- and metabasitarsus yellow. Metasoma: (43) Metasomal bands more reduced than in female; T1 band usually absent, T2, T3, and T4 bands broadly interrupted medially (sometimes T3 and T4 bands unbroken), T5 bands slightly interrupted medially, usually no band on T6 and T7.

SPECIMENS EXAMINED IN ADDITION TO TYPES.—41 (21♀, 20♂).

JAPAN. Hokkaido: Hokodate, Akagawa, 20 May 1960, M. Munakata (1♂; **SAPPORO -SHIOKAWA**), 27 May 1960, M. Munakata (1♂; **SAPPORO -SHIOKAWA**), 3 June 1960, M. Munakata (2♂; **SAPPORO -SHIOKAWA**), 26 June 1960, M. Munakata (2♂; **SAPPORO -SHIOKAWA**), 1 July 1960, M. Munakata (1♂; **SAPPORO -SHIOKAWA**), 15 July 1960, M. Munakata (1♀; **SAPPORO -SHIOKAWA**), 21 July 1960, M. Munakata (1♀; **SAPPORO -SHIOKAWA**), 26 August 1960, M. Munakata (1♂; **SAPPORO -SHIOKAWA**); Ishikari, 22 May 1966, M. Shiokawa (4♀; **SAPPORO -SHIOKAWA**), 3 July 1966, M. Shiokawa (1♀; **SAPPORO -SHIOKAWA**); Misumai, 12 May 1966, M. Shiokawa (1♂; **SAPPORO -SHIOKAWA**), Miyanomori, 20 August 1973, M. Shiokawa (3♀; **SAPPORO -SHIOKAWA**); Nishino, 19 June 1964, T. Matsumura (2♀; **SAPPORO -SHIOKAWA**); Sankakuyama, 4 May 1974, M. Shiokawa (1♂; **SAPPORO -SHIOKAWA**), 21 May 1994, M. Shiokawa (1♂; **SAPPORO -**

SHIOKAWA); Sapporo, 8 August 1923, J.F. Illingworth (1♀; **HONOLULU**), 3 June 1972, Kawano Moiwa (2♂; **NEW YORK**), 7 June 1972, Kawano Moiwa (1♀; **NEW YORK**); Sapporo (in Japanese), 7 June 1972, Kawano Moiwa (2♂; **LAWRENCE**). Honshu: Ebina, Kanagawa Prefecture, 9 May 1994, H. Nagase (1♂; **NEW YORK**), 16 May 1996, H. Nagase (1♀, 3♂; **LOS ANGELES**). Kyushu: Koyamacho, Kagoshima Prefecture, 1 October 1978, H. Nagase (1♀; **NEW YORK**)

RUSSIA. Primorskyi Krai: Gornotayozhnoye, Montain-Taiga Station, 11–15 June 1999, 43°66'N 132°25'E, M.V. Michailovskaya (2♀; **LOS ANGELES**), 23–27 June 1999, M.V. Michailovskaya (2♀; **LOS ANGELES**)

SOUTH KOREA. Gwangju: Mt. Taehwa, 22 May 1998, Seung-Hwan Lee (1♀; **SEOUL**). Suwon: Mt. Yoegi, 16 April 1994, J. Y. Choi (1♂; **SEOUL**).

***Ceratina hieratica* Baker**

FIGURE 18, 55, 89, 118, 147, 173 (see Figure section at the end of text)

Ceratina hieratica Baker, 2002a: 366, fig. 8 [Female].

TYPE MATERIAL.—Baker (2002a) indicated that the holotype is in his collection, now at the University of Kansas Natural History Museum, **LAWRENCE-BAKER**. His collection contains one specimen labeled as paratype, printed beside which is a

holotype label. He may have intended to remove the paratype label from this specimen and designate it as the holotype. It is more likely that there was a holotype, now lost or destroyed. I therefore designate as lectotype the paratype in the Baker collection at the University of Kansas; it is labeled “3. Danske Exp. Til Centralasien. St. 335. 23/4 48. Afghanistan, Wama. K. Paludan; [on red label] *Ceratina hieratica* Baker, Lectotype, N. Warrit, 2007”. The other of Baker’s paratypes (there are only two paratypes designated for this species) is in the Hope Entomological Collections, Oxford University, **OXFORD**.

DISTRIBUTION.—*Ceratina hieratica* is recorded from Afghanistan (Nuristan province and Kabul).

DIAGNOSIS AND COMPARATIVE COMMENTS.—*Ceratina hieratica* is usually small (5.00–6.00 mm. in body length), and superficially resembles *C. rugosachlypeata* but can be distinguished from the latter by the smooth (with sparse fine punctures) and shiny clypeus and paraocular area below the antennal fossa, and by the extensive yellow maculation, mostly on the prosoma and mesosoma including legs (except the absence of longitudinal lines on scutum). The yellow spot behind the pronotal lobe is large. The dorsal pronotal band is well-developed and the femora and tarsal segments are yellow.

Additional specimens collected from Kabul were examined in this revision. Both sexes were identified. Specimens from Kabul are much smaller than the type

(5.20–6.90 mm.) and the scutum is shiny and dark, without longitudinal lines (type has two vague inner lines). The apex of T7 of the male *C. hieratica* is rounded as in *C. rugosaclypeata* but without a pointed apex. The sixth sternum of the male is with two lateral teeth on the subapical depression, but without a median tooth as in *C. rugosaclypeata*.

DESCRIPTION.—**Female:** *Structure:* (1) Length 5.20–8.10 mm. Prosoma: (2) Clypeus shiny and smooth, almost impunctate but with scattered small punctures mostly along dorsal and dorsolateral margins; median longitudinal impressed area present, median carina absent. (3) Labrum rugose with scattered small punctures and many bristles; distal margin with prominent median incision. (4) Paraocular area below antennal fossa shiny and smooth, almost impunctate with scattered small punctures, mostly along compound eye margin. (5) Inner part of antennal fossa shallow with medium-sized punctures along frontal carina, outer part impunctate. (6) Dorsolateral area of antennal fossa without smooth fovea. (7) Supraclypeal area below frontal carina almost impunctate, at most with few small punctures. (8) Frons shiny, almost impunctate except for clump of medium-sized punctures between compound eye and frontal carina; vertex with more dense medium-sized to coarse punctures. (9) Space between ocelli and upper part of compound eye with few scattered medium-sized punctures. (10) Gena shiny, almost impunctate. (11) Preoccipital carina not prominent; area behind ocelli slightly depressed. (12) Hypostomal area with few scattered medium-sized punctures; hypostomal carina slightly prominent. Mesosoma:

(13) Anterior third of scutum with sparse medium-sized punctures; posterior two thirds of scutum shiny and impunctate except posterior margin; one row of punctures along anteromedian line. (14) Lateral margin of scutum lined with one or two rows of small fine punctures. (15) Procoxa with rounded angle on outer side at base. (16) Mesepisternum with dense coarse punctures laterally and ventrally; punctures posterolaterally near mesocoxa base scattered, surface shiny; large impunctate area on hypoepimeral area. (17) Area around scrobe with large conspicuous impunctate area. (18) Propodeal triangle finely coriaceous-reticulate; lateral area of propodeum densely and finely punctate, without patch of dense hair in anterior part. Metasoma: (19)–(21) See male. *Maculations* (yellow except as noted): Prosoma: (22) Inverted-T marking on clypeus well-developed; upper lobe extending above 2/3 of clypeal length, no marking on dorsal and dorsolateral margins. (23) Labrum dark brown. (24) Mandible dark brown. (25) Supraclypeal spot well-developed. (26) Frontal spot oval, well-developed. (27) Marking on paraocular area thick, straight, but curving inward along lower margin (hook-like) (Figure 18.) (28) Genal marking slightly narrowed downward; extending 2/3 of eye length. (29) Base of antennal scape dark brown. Mesosoma: (30) Transverse marking on pronotum connected to yellow spot on pronotal lobe. (31) Spot behind pronotal lobe large. (32) Scutum without longitudinal lines (except one has vague inner lines). (33) Axilla black. (34) Tegula reddish-brown translucent. (35) Scutellum with rectangular marking slightly narrowed posteriorly; small incision on anterior margin of marking. (36) Marking on metanotum absent. (37) Protrochanter and mesotrochanter with small markings at

bases apically. (38) Profemur often with yellow spot at apex extending distad on inner side for entire length of femur. (39) Protibia and mesotibia yellow. (40) Metatibia yellow. (41) Tarsi dark yellow. (42) Metabasitarsus yellow. Metasoma: (43) Metasomal bands well developed and mostly unbroken; T1 with wide marking almost enclosing black spot laterally, T3 with band slightly interrupted medially, no band on T6.

Male: as described for female except as follows: *Structure*: (1) Length 4.90–6.70 mm. Prosoma: (3) Labrum smooth (sometimes slightly rugose) with few small punctures. (4) Paraocular area below antennal fossa smooth, almost impunctate, with few scattered small punctures. (8) Frons shiny, but with more punctures than in female. Metasoma: (19) S6 with two medium-sized submedian teeth without median projection on subapical depression (Figure 147); anterior part of S6 with medium-sized and dense punctures and stiff long bristles (no bristles near teeth); apical lobe prominent. (20) T7 apically round; lateral angle of T7 round. (21) Distal part of gonocoxite broad at apex, with bristles along apical margin; inner margin of gonocoxite rounded. *Maculations* (yellow except as noted): Prosoma: (22) Inverted-T marking on clypeus well-developed, occupying entire area. (23) Labrum yellow enclosing three small spots. (24) Mandible dark brown (sometimes with vague yellow spot at apex). (25) Supraclypeal spot well-developed and large. (26) Frontal spot reduced to small spot. (27) Marking on paraocular area well-developed, occupying entire area (Figure 118). (28) Genal marking streak-like; extending $\frac{1}{4}$ of

eye length. (29) Base of antennal scape dark brown (sometimes with yellow spot); apex yellow (sometimes dark brown). Mesosoma: (31) Spot behind pronotal lobe small. (35) Scutellum with rectangular marking, narrowed posteriorly; anterior margin of marking with slight median incision. (37) Procoxa sometimes with yellow marking on ventral side. (38) Profemur with yellow marking on inner and outer sides of apex, extending basad for almost entire length of tibia. (39) Protibia and mesotibia yellow. (40) Metatibia yellow. (41) Tarsi yellow. (42) Metabasis yellow. Metasoma: (43) Metasomal bands well-developed; T1 band almost enclosing two small black spots, T2 and T3 bands often interrupted medially, T4–T6 with unbroken bands on median area, no band on T7.

SPECIMENS EXAMINED IN ADDITION TO TYPE.—33 (6♀, 27♂).

AFGHANISTAN. Kabul: Kabul Parvan qtr., 1,800 m., 6 April 1979, P. H. B. Baker (6♀, 15♂; **LAWRENCE-BAKER**), 23 April 1979, P. H. B. Baker (3♂; **LAWRENCE-BAKER**), 24 April 1979, P. H. B. Baker (8♂; **LAWRENCE-BAKER**), 15 May 1979, P. H. B. Baker (1♂; **LAWRENCE-BAKER**).

Ceratina hieroglyphica Smith

Ceratina hieroglyphica Smith, 1854: 226 [female and male descriptions, part (Hong Kong specimen)]; van der Vecht, 1952: 49 [selected female lectotype from Hong Kong and provided additional descriptions]; Wu, 1963: 84 [records

from South China]; 2000: 175, fig. 1 [record from China]; Shiokawa, 2002: 411–413, fig. 1 [redescriptions of female and male].

? *Ceratina denticulata* Wu, 1963: 86, 91, fig. 82 [female and male; so far as can be judged from a disintegrated allotype and from Wu's original description *C. denticulata* might be a synonym of either *C. bryanti* or *C. hieroglyphica*].

Ceratina bowringi Baker, 2002a: 364–365, fig. 7, 12, 14 [female and male descriptions]; based on van der Vecht's female lectotype of *C. hieroglyphica*.

new synonym

TYPE MATERIAL.—The female lectotype of *C. hieroglyphica* in the Natural History Museum, **LONDON**, is labeled “Hong Kong”, “B.M. TYPE HYM. 17a 2643b”, “selected as type of *Ceratina hieroglyphica* Sm. 1854 by J. v. d. Vecht 1951”, “B.M. TYPE HYM. 17a 3139”, and “Vecht overlooked type of *Ceratina hieroglyphica* Smith, which was *hors série* in type collection. His lectotype designation (1952) is invalid. *C. hieroglyphica* Sm., Vecht is another species. DB [Donald Baker]”. The type is in good condition.

Smith (1854) proposed the name *C. hieroglyphica* for ceratinine bees with yellow maculation. Smith's original material comprised specimens collected from Northern India, Hong Kong, and The Philippines. The Philippine material was later recognized by Smith (1879) as being distinct from the other specimens and was redescribed under the name *C. compacta*. At the same time, Smith provided a name for the species from Northern India (*C. lepida* Smith). In 1952, van der Vecht

selected the specimen from Hong Kong as the lectotype of *C. hieroglyphica* (he did not see the material from Northern India). Later, Baker (2002a) claimed that van der Vecht's lectotype designation is invalid, and stated in his paper that he has filed an application to the International Commission on Zoological Nomenclature to suppress van der Vecht's lectotype designation and designated Smith's original specimen from Northern India as the lectotype of *C. hieroglyphica*. In an attempt to suppress van der Vecht lectotype designation, Baker designated the van der Vecht lectotype (from Hong Kong) as a new species, *C. bowringi*. No such action to the commission from Baker was made. The lectotype designated by van der Vecht (specimen from Hong Kong) is the valid name-bearing type of *C. hieroglyphica*. The specimen from Northern India is a different species (*C. lepida*) as recognized here and by van der Vecht (1952).

The male holotype of *C. denticulata* is in the Academia Sinica (Chinese Academy of Sciences, **BEIJING** (not seen). The female allotype in the same institution as the holotype is labeled “[locality in Chinese], 200 m., 1956. VI. 11”, “Allotype”, “IOZ (E) 206055”, and “*Ceratina denticulata* Wu ♀”. The allotype was in poor condition when it arrived at the University of Kansas for examination. The head and metasoma fell apart from the mesosoma; the head was missing from inside the container carrying the type and was lost; most parts of the leg segments broke off from the mesosoma.

DISTRIBUTION.—*Ceratina hieroglyphica* is known from South China (Fukien), Hong Kong.

DIAGNOSIS AND COMPARATIVE COMMENTS.—The female *C. hieroglyphica* can be distinguished from most *Ceratinidia* species by the pattern of punctation on the paraocular area, where medium-sized to coarse punctures are clumped together on the median part, and only few punctures are present on lower and upper parts. *Ceratina hieroglyphica* closely resembles *C. bryanti*, but can be distinguished from the latter by the depressed posterior part of the vertex (flat in *C. bryanti*) and by the presence of two or more rows of punctures along the outer side of the parapsidal furrow. S6 and T7 for the males of *C. hieroglyphica* and *C. bryanti* are similar (according to the figures in Shiokawa (2002)). Because of the lack of male specimens of *C. hieroglyphica*, I cannot conclude whether *C. hieroglyphica* is conspecific with *C. bryanti* or not. At this time, I treat them as separate species.

Based on Wu's description (1963) and illustrations of *C. denticulata*, it is somewhat convincing to think that *C. denticulata* is a synonym of *C. bryanti* or *C. hieroglyphica*. The marking on the clypeus and paraocular area below antennal fossa, the submedian teeth on S6 (Wu's illustration did not indicate the presence of a small median denticle between the submedian teeth), and T7 of the male of *C. denticulata* is similar to that of *C. bryanti* and *C. hieroglyphica*. However, markings on the pronotum, scutum, and legs from the female allotype of *C. denticulata* are absent or more reduced than in the two latter species.

DESCRIPTION—**Female:** *Structure:* (1) Length 7.60–9.65 mm. Prosoma: (2) median longitudinal impressed area of clypeus absent or at most vague; dorsal and dorsolateral area of clypeus with sparse to dense medium-sized punctures; median and lower parts of clypeus smooth, almost impunctate; median longitudinal carina absent. (3) Labrum with mixture of medium-sized and coarse punctures and with many bristles. (4) Paraocular area below antennal fossa with dense, small to coarse punctures, clumped together on middle part, few punctures on lower part. (5) Inner part of antennal fossa with coarse punctures along frontal carina, outer part impunctate or with few punctures. (6) Dorsolateral area of antennal fossa without conspicuous smooth fovea. (7) Supraclypeal area below frontal carina with 1–2 punctures. (8) Frons and vertex with dense and coarse punctures. (9) Space between ocelli and upper part of compound eye with sparse coarse punctures. (10) Gena shiny, almost impunctate. (11) Preoccipital carina not prominent; area behind ocelli slightly depressed. (12) Hypostomal area with scattered medium-sized punctures; hypostomal carina slightly prominent. Mesosoma: (13) Anterior third of scutum densely punctate; posterior two thirds of scutum shiny and impunctate except posterior margin; two or more rows of punctures along outer side of parapsidal furrow. (14) Lateral margin of scutum lined with two or more rows of small fine punctures. (15) Procoxa with round angle on outer side at base. (16) Mesepisternum with dense coarse punctures laterally and ventrally; punctures slightly less dense posterolaterally near mesocoxal base. (17) Small area around scrobe impunctate.

(18) Propodeal triangle finely coriaceous-reticulate; lateral area of propodeum densely and finely punctate, with patch of dense hair anteriorly. Metasoma (19)–(21) See male. *Maculations* (yellow except as noted): Prosoma: (22) Upper lobe of inverted-T marking of clypeus reaching half of clypeal length or more; lateral arm of marking with small hook pointed downward. (23) Labrum black. (24) Mandible black. (25) Supraclypeal spot well-developed. (26) Frontal spot oval, well-developed. (27) Marking on paraocular area thick linear and hooked inward along lower margin. (28) Genal marking slightly narrowed downward; extending 2/3 of eye length. (29) Base of antennal scape black. Mesosoma: (30) Transverse marking on pronotum barely connected to yellow spot on pronotal lobe. (31) Spot behind pronotal lobe absent. (32) Scutum with four longitudinal lines. (33) Axilla black. (34) Tegula reddish-brown translucent, sometimes with small marking. (35) Scutellum with more or less rectangular marking; small incision on anterior margin of marking. (36) Marking on metanotum absent. (37) Protrochanter and mesotrochanter with vague markings on outer side apically (sometimes absent). (38) Profemur dark brown, with yellow spot on inner and outer side; marking on outer side extending for half of femur. (39) Protibia with yellow marking on outer side extending distally for half to entire of tibial length; mesotibia black, sometimes with small spot at base. (40) Metatibia with yellow spot at base extending for half of tibial length. (41) Tarsi dark brown. (42) Metabasis dark brown. Metasoma: (43) Metasomal bands well developed and unbroken; no band on T6; T1 with wide marking not enclosing two black spots.

Male: As described by Shiokawa (2002): *Structure:* (1) Length 9.00 mm. Prosoma: (2) median longitudinal impressed area of clypeus vague; dorsal and dorsolateral area of clypeus with sparse to dense medium-sized punctures; median and lower parts of clypeus smooth, with few small punctures. (4) Paraocular area below antennal fossa with dense, small to coarse punctures, clumped together on middle part, few punctures on lower part. (8) Frons densely and coarsely punctate; vertex with sparse and coarse punctures. (11) Preoccipital carina prominent; area behind ocelli depressed. (12) Hypostomal area with scattered medium-sized punctures; hypostomal carina slightly prominent. Mesosoma: (13) Anterior fourth of scutum densely punctate; posterior two thirds of scutum shiny and impunctate except posterior margin; two or more rows of punctures along outer side of parapsidal furrow. (16) Mesepisternum with dense coarse punctures laterally and ventrally; punctures slightly less dense posterolaterally near mesocoxal base. Metasoma (19) S6 with medium-sized submedian tooth and small median tooth on subapical depression. (20) T7 apically pointed with rounded on lateral angle. (21) Distal part of gonocoxite broad, with bristles along apical margin; inner margin of gonocoxite nearly round.

Maculations (yellow except as noted): Prosoma: (22) Upper lobe of inverted-T marking of clypeus more reduced than in female, triangulate apically. (23) Labrum with vague marking. (25) Supraclypeal spot more reduced than in female. (26) Frontal spot more reduced than in female. (27) Marking on paraocular area below antennal fossa widened below and abruptly tapered above. (28) Genal marking slightly narrowed downward; extending 1/3 of eye length. (29) Base of antennal

scape black. Mesosoma: (30) Transverse marking on pronotum broken, barely connected to yellow spot on pronotal lobe. (32) Scutum without longitudinal lines. (35) Scutellum with more or less rectangular marking; small incision on anterior margin of marking. (38) Profemur dark brown, with yellow spot on inner and outer side. (39) Protibia with yellow marking on outer side extending distally; mesotibia with small spot at base. (40) Metatibia with yellow spot at base. (41) Tarsi dark brown. (42) Metabasitarsus dark brown. Metasoma: (43) Metasomal bands more reduced than in female; T1 and T6 without bands, T2–T5 with wide marking interrupted medially.

SPECIMENS EXAMINED IN ADDITION TO TYPES.—15♀.

CHINA. Fukien: Futsing, 1938, H. Caldwell (1♀; **NEW YORK**); Shaowu, 16 March 1942, T. C. Maa (1♀; **LOS ANGELES**), 25 July 1943, T. C. Maa (1♀; **LOS ANGELES**). Hong Kong: Lantau Island, Shui Hau, 20–50 m., 22° 22'N, 113° 92'E, 2 July 1996, R. R. Snelling (2♀; **LOS ANGELES**); Peng Chau Island, 5–20 m., 22° 30'N, 114° 05'E, 25 June 1996, R. R. Snelling (1♀; **LOS ANGELES**); Po Toi Island, 20 m., 22 17N, 114 25E, 2021 June 1996, R. R. Snelling (5♀; **LOS ANGELES**); Sai Kung, Long Ke, 12 July 1964, W. J. Woss (1♀; **HONOLULU**); June 1925, D. T. Fullaway (2♀; **HONOLULU**). Taipo: April 1925, D. T. Fullaway (1♀; **LOS ANGELES**).

Ceratina incertula Cockerell *Incertae Sedis*

FIGURE 20 (see Figure section at the end of text)

Ceratina incertula Cockerell, 1937: 12 [Female]

TYPE MATERIAL.—The female holotype at the American Museum Of Natural History, New York, is labeled “Nan Siam, January 13, Alice Mackie”. The type is in good condition.

DISTRIBUTION.—Only one specimen is known; it is from Nan Province, Thailand

DIAGNOSIS AND COMPARATIVE COMMENTS.—*Ceratina incertula* was synonymized by van der Vecht (1952) under *C. collusor*. However, van der Vecht did not examine the type personally, but based his opinion on Cockerell’s description (1937) and concluded that *C. incertula* is a dark form of *C. collusor*. I have examined the type of *C. incertula* and found that it is not the same species as *C. collusor*, as shown by the presence of punctures along the parapsidal furrow and the area between the furrow and the lateral margin of scutum, and by the absence of a protuberance on the outer side of the procoxa.

Ceratina incertula is so similar to *C. compacta* that I am even uncertain about its validity as a separated species. The punctation on the scutum of *C. incertula* is consistent with some Island populations (e.g., Luzon) of *C. compacta* in the Philippines, but differs from many including *C. compacta* from Thailand. In all Thai

C. compacta, the scutum is heavily punctate, with almost no impunctate area; but in *C. incertula*, the impunctate area is obvious between the anteromedian line and parapsidal furrow. I retain *C. incertula* as a separate species from *C. compacta* for the time being. As more specimens are collected, we will learn more about the variations of these forms. Therefore, I do not describe *C. incertula* in detail but one can recognize it by the way of the *C. compacta* description, with the modification indicated above.

If *C. incertula* is found to be indeed *C. compacta*, it indicates that the species was in Thailand before 1937, and this rejects a major component in the theory that the species is adventive in Thailand (Warrit, 2007). Specimens considered to be *C. compacta* were not collected in Thailand before 1988.

***Ceratina interrupta* Alfken**

FIGURE 21, 57, 91, 120, 149, 175 (see Figure section at the end of text)

Ceratina interrupta Alfken, 1926: 268 [female and male]; van der Vecht, 1952: 83
[notes on holotype and paratypes].

TYPE MATERIAL.—Alfken (1926) designated 3♀ and 1♂ as the type series of *C. interrupta*. According to van der Vecht (1952), one female paratype is in the Nationaal Natuurhistorisch Museum, **LEIDEN**, and labeled “9 June 1921, on Compositae” and “*C. interrupta*, det. Alfken, cotype”. Two types, in the Museum für

Naturkunde der Humboldt-Universität, **BERLIN**, are labeled “Buru 1921 Station g. 12 VI leg. L. J. Toxopeus, *Ceratina interrupta* ♀ Type Alfken det.” and “Buru 1921 Station g. 12 VI leg. L. J. Toxopeus, *Ceratina interrupta* ♂ Type Alfken det.”. Since Alfken and van der Vecht did not designate a lectotype for the name *C. interrupta*, I therefore designate as lectotype the type in **LEIDEN**; and add a red label “*Ceratina interrupta* Alfken, Lectotype, N. Warrit, 2007”.

DISTRIBUTION.—*Ceratina interrupta* is known from the Buru and Ambon Islands of the Maluku Islands (Mollucas) of Indonesia.

DIAGNOSIS AND COMPARATIVE COMMENTS.—*Ceratina interrupta* can be easily distinguished from other *Ceratinidia* by the presence of a deep median incision in the upper lobe of the clypeal marking. In the female, the incision can range from half of the clypeal length to the entire length, in which case it divides the marking in half. The upper lobe of the clypeal marking in the male *C. interrupta* is less developed than in the female (at most reaching 2/3 of clypeal length) and is sometimes absent, but one can still recognize the presence of the median incision.

DESCRIPTION—**Female:** *Structure:* (1) Length 6.90–9.80 mm. Prosoma: (2) Clypeus smooth (sometimes slightly rugose); lateral and upper area with scattered medium-sized puncture; median area more or less impunctate with broad depressed area, sometimes smooth; median longitudinal carina often vague (in some specimens

prominent); lower part of clypeus with few punctures. (3) Labrum with mixture of medium-sized and coarse punctures and some short bristles. (4) Paraocular area below antennal fossa smooth (sometimes slightly rugose) with scattered small and medium-sized punctures. (5) Inner part of antennal fossa with dense coarse punctures along frontal carina, outer part with scattered coarse punctures. (6) Dorsolateral part of antennal fossa area with small smooth fovea. (7) Supraclypeal area below frontal carina impunctate or at most with 1–2 punctures, and with ventral depression. (8) Frons and vertex with dense coarse punctures above antennal fossa. (9) Space between ocelli and upper part of compound eye with fairly dense coarse punctures. (10) Genal area with dense coarse punctures. (11) Preoccipital carina not prominent; area behind ocelli slightly depressed. (12) Hypostomal area with fairly dense coarse punctures. Mesosoma: (13) Anterior portion of scutum with dense medium-sized punctures extending posteriorly along lateral margin, parapsidal furrow, and anteromedian line; posterior area with dense punctures; small area between lateral margin and parapsidal furrow impunctate; area between parapsidal furrow and anteromedian line impunctate. (14) Lateral margin of scutum lined with two or more rows of coarse punctures. (15) Procoxa slightly angulated with small projection on outer side at base (sometimes blunted). (16) Mesepisternum with dense medium-sized punctures laterally and posterolaterally near mesocoxal base, punctures coarse but less dense on ventral side. (17) Area around scrobe with small conspicuous impunctate area, almost unnoticeable. (18) Propodeal triangle finely coriaceous-reticulate; lateral area of propodeum densely and finely punctate, with small patch of

dense hair anteriorly. Metasoma: (19)–(21) See male. *Maculations* (yellow except as noted): Prosoma: (22) Upper lobe of inverted-T marking of clypeus deeply incised on upper margin, sometimes incision dividing marking into halves. (23) Labrum black, often with vague yellow spot. (24) Mandible black. (25) Supraclypeal spot more or less narrow. (26) Frontal spot narrow. (27) Marking on paraocular area narrow, slightly and gradually widened from top to bottom (Figure 21). (28) Genal marking slightly narrowed downward; extending half to 2/3 of eye length. (29) Base of antennal scape ferruginous. Mesosoma: (30) Transverse marking on pronotum often medially interrupted, barely connected to yellow spot on pronotal lobe. (31) Spot behind pronotal lobe small. (32) Scutum without yellow longitudinal lines. (33) Axilla black. (34) Tegula dark reddish-brown translucent. (35) Scutellum with more or less triangular marking; anterior margin with small incision. (36) Marking on metanotum absent. (37) Protrochanter and mesotrochanter usually with markings apically. (38) Profemur dark brown with yellow spot at apex, extending basad on inner side for half of femoral length. (39) Protibia and mesotibia dark brown with yellow marking on outer sides extending almost entire lengths. (40) Metatibia dark brown with small yellow spot at base. (41) Tarsi ferruginous to dark brown. (42) Metabasisarsus dark brown. Metasoma: (43) Metasomal bands thin and reduced; T1 band often not well developed, T2 and T3 bands broadly interrupted medially, T4 and T5 bands unbroken, no band on T6.

Male: As described for female except as follows: *Structure:* (1) Length 6.40–7.90mm. Prosoma: (2) Median area of clypeus smoother, with fewer punctures than in female. (4) Paraocular area below antennal fossa slightly rugose with scattered small and medium-sized punctures, denser than in female. (10) Genal area with dense coarse punctures; punctures larger and denser than in female. (12) Hypostomal area with fairly dense coarse punctures; less dense on lower part. Metasoma: (19) S6 with V-shaped ridge on subapical depression, with small denticle on each side of ridge (Figure 149); anterior part of S6 with fairly dense, medium-sized punctures and sparse short bristles (no bristles near ridge or lateral margin); apical lobe not prominent. (20) T7 apically truncate with small median emargination; lateral angle rounded. (21) Distal part of gonocoxite of genitalia slightly narrowed, with two turfs of bristles on apical margin; inner margin of gonocoxite rounded. *Maculations* (yellow except as noted): Prosoma: (22) Upper lobe of inverted-T marking on clypeus not as developed as in female (at most reaching half of clypeal length). (23) Labrum with yellow spot. (25) Supraclypeal spot linear and more reduced than in female, sometimes with small incision on lower margin of marking. (26) Frontal spot often absent. (27) Marking on paraocular area narrow (sometimes linear or gradually widened from top to bottom) (Figure 120). Mesosoma: (31) Spot behind pronotal lobe small; sometimes absent. (39) Protibia and mesotibia with yellow markings on outer sides extending almost entire tibial lengths. (40) Metatibia dark brown with small yellow spot at base. (41) Protarsus and mesotarsus ferruginous to yellow; metatarsi dark brown. Metasoma: (43) Metasomal bands narrow and reduced; T1

band often not well developed, T2, T3, and T4 bands broadly interrupted medially, T5 band unbroken, no bands on T6 and T7.

SPECIMENS EXAMINED IN ADDITION TO TYPES.—24 (15♀, 9♂).

INDONESIA. Ambon: Waai, February 1964, A.M.R. Wegner (1♀; **HONOLULU**), 27 November 1964, A.M.R. Wegner (1♂; **HONOLULU**), 27 December 1964, A.M.R. Wegner (1♀; **HONOLULU**), 23 January 1965, A.M.R. Wegner (1♂; **HONOLULU**), 12 March 1965, A.M.R. Wegner (1♀; **HONOLULU**), 9 April 1965, A.M.R. Wegner (1♀; **HONOLULU**), 11 June 1965, A.M.R. Wegner (1♀; **HONOLULU**), 8 July 1965, A.M.R. Wegner (1♂; **HONOLULU**), 9 October 1965, A.M.R. Wegner (1♂; **HONOLULU**), 3 December 1965, A.M.R. Wegner (1♂; **HONOLULU**), 9 January 1966, A.M.R. Wegner (1♀; **HONOLULU**), 25 February, 1966, A.M.R. Wegner (2♂; **SAN FRANCISCO**), 29 March 1966, A.M.R. Wegner (2♀; **SAN FRANCISCO**), 28 March 1966, A.M.R. Wegner (1♂; **SAN FRANCISCO**), 29 March 1966, A.M.R. Wegner (2♂; **SAN FRANCISCO**), 11 April 1966, A.M.R. Wegner (2♀; **SAN FRANCISCO**), 14 November 1966, A.M.R. Wegner (1♀; **SAN FRANCISCO**), December 1966, A.M.R. Wegner (2♀; **SAN FRANCISCO**), February 1967, A.M.R. Wegner (1♀; **SAN FRANCISCO**), 24 November 1967, A.M.R. Wegner (1♀; **SAN FRANCISCO**), 2 December 1967, A.M.R. Wegner (2♀; **SAN FRANCISCO**), 3 December 1967, A.M.R. Wegner (1♀, 1♂; **SAN FRANCISCO**); 4 December 1967, A.M.R. Wegner (1♀; **SAN FRANCISCO**)

***Ceratina jacobsoni* van der Vecht**

FIGURE 22, 58, 92, 121 (see Figure section at the end of text)

Ceratina jacobsoni van der Vecht, 1952: 74–75 [Female, male]

TYPE MATERIAL.— The male holotype of *C. jacobsoni* in the Nationaal Nuurhistorisch Museum, **LEIDEN** (not seen), is labeled “W. Java Tandjong Priok, 21 February 1937, F. Dupont leg”. The female allotype, in the same institution as the holotype, is labeled “W. Java Tandjong Priok, 21 February 1937, F. Dupont leg”. The allotype is in good condition. .

DISTRIBUTION.—*Ceratina jacobsoni* is recorded from Java, Indonesia. However, one specimen is from Vientiane Province, Laos. This specimen agrees well in punctuation with the Java specimens, but has more extensive maculation on the paraocular area, scutellum, and terga.

DIAGNOSIS AND COMPARATIVE COMMENTS.—*Ceratina jacobsoni* is closely allied to *C. cognata*. Punctuation on the posterolateral area of the mesepisternum near the mesocoxal base is the same in both species. In *C. jacobsoni*, the female differs from *C. cognata* by the presence of longitudinal yellow lines on the lateral areas of the scutum. Other characters are the same in both species.

Ceratina jacobsoni may be another form of *C. cognata*, as indicated by the similarity in the overall characters, though I did not examine the male holotype to prove otherwise. However, I examined a number of male *C. bryanti* from nearby areas in Java and found that most characters of the male *C. bryanti* are as in the description of male *C. jacobsoni*. Van der Vecht (1952) might have erroneously described the male *C. bryanti* as *C. jacobsoni* because of the presence of the outer longitudinal lines on scutum. This is only a speculation; until the holotype is examined and more specimens are acquired, I am treating *C. jacobsoni* as a different entity from *C. cognata* and *C. bryanti*. The description below is based on the female allotype.

DESCRIPTION—**Female:** *Structure:* (1) Length 7.25 mm. Prosoma: (2) Clypeus more or less smooth with scattered shallow punctures along margin, mostly on upper part; median impressed area with vague longitudinal median carina. (3) Labrum with mixture of medium-sized and coarse punctures, and with long stiff bristles. (4) Paraocular area below antennal fossa more or less smooth with scattered shallow medium-sized punctures. (5) Inner part of antennal fossa with medium-sized to coarse punctures along frontal carina, outer part impunctate or at most with few punctures; however, area between antennal fossa and eye with dense coarse punctures. (6) Dorsolateral area of antennal fossa area without distinct smooth fovea. (7) Supraclypeal area below frontal carina with scattered shallow punctures, and with ventral depression. (8) Frons and vertex with coarse dense punctures. (9) Space

between ocelli and upper part of compound eye with some coarse punctures, not as dense as on frons and vertex. (10) Gena with shallow scattered punctures. (11) Preoccipital carina not prominent; area behind ocelli slightly depressed. (12) Hypostomal area with few shallow punctures. Mesosoma: (13) Anterior third of scutum with dense medium-sized punctures; posterior two thirds of scutum with punctures along anteromedian line and parapsidal furrow; dense punctures on posterior margin before scuto-scutellar sulcus; small impunctate area between anteromedian line and parapsidal line. (14) Lateral edge of scutum lined with two or more rows of medium-sized punctures. (15) Procoxa with round angle on outer side at base. (16) Mesepisternum with dense coarse punctures laterally; punctures larger ventrally but less dense; less dense punctures posterolaterally near mesocoxal base. (17) Area around scrobe with conspicuous impunctate area. (18) Propodeal triangle finely coriaceo-reticulate; lateral area densely and finely punctate, without patch of dense hairs anteriorly. Metasoma: (19)–(21) See male. *Maculations*: Prosoma: (22) Inverted-T marking on clypeus well-developed; upper median lobe reaching 2/3 of clypeal length; margin of clypeus without marking. (23) Labrum black. (24) Mandible black. (25) Supraclypeal marking well-developed. (26) Frontal spot linear. (27) Marking on paraocular area linear (Figure 22). (28) Genal marking slightly narrowed downward, extending 2/3 of the eye length. (29) Base of antennal scape black. Mesosoma: (30) Transverse marking on pronotum connected with thin yellow line to yellow spot on pronotal lobe. (31) Spot behind pronotal lobe absent. (32) Scutum with two outer lateral longitudinal lines. (33) Axilla black. (34) Tegula

reddish-brown translucent. (35) Scutellum with triangular marking; small incision on anterior margin of marking. (36) Marking on metanotum absent. (37) Protrochanter and mesotrochanter black, without marking. (38) Apex of profemur with yellow markings on both inner and outer sides; yellow marking on inner side extending basally 2/3 of femoral length. (39) Yellow markings present on outer sides of protibia and mesotibia at bases and extending distad for entire lengths. (40) Metatibia with yellow marking at base. (41) All tarsi brown black. (42) Metabasitarsus black. Metasoma: (43) Metasomal bands thin and unbroken; T1 with three or four separated spots; T6 band absent.

SPECIMEN EXAMINED IN ADDITION TO TYPE.—1♀

LAOS: Vientiane, Gi Sion Village, de Tha Ngone, 7–21 February 1965, Native Collector (1♀; **HONOLULU**)

Ceratina japonica Cockerell

FIGURE 23, 59, 93, 122, 150, 176 (see Figure section at the end of text)

Ceratina hieroglyphica var. *japonica* Cockerell, 1911: 635 [female]; Shiokawa, 1963: 278 [recognized as species; redescription of female and male]; Yasumatsu and Hirashima, 1969: 68 [mentioned in key]; Kim, 1999: 7–11, fig. 1–3 [notes on variation]; ? Wu, 2000: 155–158, 170 [record from China]; Baker, 2002a:

360, fig. 4 [notes on characters]; Lee, 2005: 137–146 [record from Korea; host plants data].

Ceratina japonica fukiensis Shiokawa, 2002: 415–416 [male and female].

TYPE MATERIAL.—The female holotype of *Ceratina japonica* in the United States National Museum of Natural History, The Smithsonian’s Institution, **WASHINGTON, D.C.**, is labeled “Type No 13420 U.S.N.M.” “Japan Koebele”. The type is in good condition.

The male holotype of *C. j. fukiensis* in the Bishop Museum, **HONOLULU** (not seen), is labeled “FUKIEN, S. China, Chungan: Lower, Kuatun, 3. VI.1942, T. C. Maa”.

DISTRIBUTION.—*Ceratina japonica* is found in Japan (except Ryukyu Islands) and the Korean Peninsula (perhaps in South China, if *C. j. fukiensis* is a geographical variation of *C. japonica*).

DIAGNOSIS AND COMPARATIVE COMMENTS.—*Ceratina japonica* can be distinguished from other *Ceratinidia* by having the two thirds of to the entire hypoepimeral area impunctate, shiny, and hairless. The yellow maculation is highly reduced. Marking on clypeus at most reaches half of the clypeal length (sometimes with median incision that divides marking in half); the transverse band on the pronotum is often absent; the spots behind the pronotal lobe absent; the marking on

the scutellum is small, triangular or reduced to one or two small spots; the scutum usually lacks longitudinal yellow lines (if present, lines are vague).

In *C. japonica*, yellow maculation is highly variable among individuals, even specimens collected from the same locality. Kim (1999) identified three parts of the body where maculation of *C. japonica* is hypervariable: (1) spot on frontal area (2) marking on paraocular area and (3) marking on scutellum.

The sympatric species, *C. flavipes*, is similar to *C. japonica* but can be distinguished from the latter by the absence of the upper lobe of the inverted-T marking on the clypeus (sometimes the marking on clypeus absent) and by the presence of a yellow marking extending for half of the mesotibial length (in female *C. japonica* the marking is usually absent or at most present as a spot). In male of *C. japonica*, the submedian tooth on the subapical depression of S6 is at most 2 times longer than wide, and the median denticle between the submedian teeth is present. In *C. flavipes*, the lateral teeth of S6 are 3 times longer than wide (sometimes apically bent outward), and there is no median denticle. Besides the morphological differences between the two species, the social behavior differs. *Ceratina japonica* usually forms colonies (with two or more females in the same nest), whereas *C. flavipes* is strictly solitary in the field [see Chapter 1 for details].

COMMENTS.—Shiokawa (2002) proposed a subspecies, *C. japonica fukiensis* from southeastern China. The holotype was said to be deposited at the Bishop Museum, **HONOLULU**, though none of the staff there have been able to locate this type (A.

Samuelson pers. comm.). The author of this subspecies indicated the diagnostic characters to be distinctly rugose and coarsely punctate clypeus in both sexes. I have not examined any of the specimens bearing the name *C. japonica fukiensis*; thus, I could not confirm or reject the validity of this subspecies, but I tentatively list it as a synonym.

DESCRIPTION—**Female:** *Structure:* (1) Length 6.50–9.10 mm. Prosoma: (2) Clypeus rugose, degree of rugosity highly varied, strongest in median area; small to coarse punctures along margin, mostly on upper, upper lateral, and lower margins; median impressed area and median longitudinal carina present. (3) Labrum with dense small and medium-sized punctures, and with some bristles. (4) Paraocular area below antennal fossa shiny (sometimes rugose) with few scattered small to medium-sized punctures. (5) Inner part of antennal fossa with sparse medium-sized punctures along frontal carina, outer part with scattered punctured. (6) Dorsolateral area above antennal fossa without small smooth fovea. (7) Supraclypeal area below frontal carina with 1–2 punctures. (8) Frons with scattered coarse punctures (some specimens with clump of punctures); vertex with fairly dense coarse punctures. (9) Space between ocelli and upper part of compound eye almost impunctate, at most with few punctures. (10) Genal area shiny, almost impunctate. (11) Preoccipital carina not prominent; area behind ocelli slightly depressed. (12) Hypostomal area almost impunctate and depressed. Mesosoma: (13) Anterior fourth to third of scutum fairly densely punctated with small punctures; posterior two thirds to three fourths

densely punctured; along median line with at least one row of punctures; few or row of punctures along parapsidal furrow. (14) Lateral margin of scutum lined with at most one row of small punctures. (15) Procoxa with rounded angle on outer side at base. (16) Mesepisternum with scattered medium-sized punctures laterally (some specimens with few punctures), less dense posterolaterally near mesocoxal base, ventral side with dense fine puncture; entire mesepisternal surface with dense bristles; large impunctate area on hypoepimeral area; and with dense long bristles. (17) Area around scrobe with large conspicuous impunctate area. (18) Propodeal triangle finely coriaceous-reticulate; lateral area of propodeum densely and finely punctate, without patch of dense hair anteriorly. Metasoma: (19)–(21) See male. *Maculations* (yellow except as noted): Prosoma: (22) Upper lobe of inverted-T marking on clypeus reaching at most half of clypeal length (sometimes with median incision on upper and/or lower margins; sometimes median incision separating transverse part into halves); lateral arm terminally constricted often attaching to lateral spot. (23) Labrum black. (24) Mandible black. (24) Supraclypeal spot well-developed. (26) Frontal spot near frontal carina small, oval, sometimes reduced to small spot. (27) Marking on paraocular area linear, curved inward below (hook-like), often interrupted medially (sometimes only remnant or upper part of marking absent) (Figure 23). (28) Genal marking streak-like; extending half of eye length. (29) Base of antennal scape black. Mesosoma: (30) Transverse marking on pronotum, often interrupted medially (sometimes absent), not connected to yellow spot on pronotal lobe (sometimes yellow spot absent). (31) Spot behind pronotal lobe absent. (32) Scutum usually without

yellow longitudinal lines (sometimes with two vague inner and/or outer lines). (33) Axilla black. (34) Tegula often reddish brown, sometimes gray translucent. (35) Scutellum with triangular marking, anterior margin with small incision (specimens from Hokkaido with two yellow spots). (36) Marking on metanotum absent. (37) Protochanter and mesotrochanter usually without yellow apically. (38) Profemur dark brown often without yellow spot at apex. (39) Protibia dark brown with yellow marking on outer side extending for half of tibial length; mesotibia dark brown with yellow spot at apex. (40) Metatibia dark brown, often with small yellow spot at apex. (41) Tarsi dark brown. (42) Metabasitarsus dark brown. Metasoma: (43) Metasomal bands well-developed; T1 band not enclosing small spot, T2 and T3 bands interrupted medially (sometimes T3 band unbroken), T4 and T5 bands unbroken, no band on T6.

Male: As described for female except as follows: *Structure*: (1) Length 5.85–8.20 mm. Prosoma: (2) Clypeus smooth superficially rugose; small punctures mostly on upper and upper lateral margins; median longitudinal carina absent (sometimes present, but vague). (3) Labrum smooth with few scattered small punctures. (4) Paraocular area below antennal fossa smooth with shallow scattered small punctures. (5) Inner part of antennal fossa with sparse medium-sized punctures along frontal carina, outer part impunctate. (7) Supraclypeal area below frontal carina impunctate. (8) Frons with clump of coarse punctures next to frontal carina and scattered long bristles; vertex with fairly dense coarse punctures and scattered long bristles. (10) Genal area shiny with scattered punctures. (12) Hypostomal area almost impunctate

with scattered long bristles. Mesosoma: (13) Punctures on anterior portion of scutum less dense than in female. Metasoma: (19) S6 with medium-sized submedian tooth and small median projection on subapical depression; median projection with median incision (Figure 150); anterior part of S6 with medium-sized and dense punctures and stiff long bristles (no bristles near tooth); apical lobe not prominent. (20) T7 apically slightly pointed, almost truncate; lateral angle of T7 rounded. (21) Distal part of gonocoxite of genitalia slightly broadened at apex, with bristles along apical margin; inner margin of gonocoxite rounded, almost crescentic. *Maculations* (yellow except as noted): Prosoma: (22) Inverted-T marking on clypeus well-developed, occupying almost entire area except upper margin. (23) Labrum with extensive yellow marking. (24) Mandible black, often with small yellow spot. (26) Frontal spot near frontal carina absent. (27) Marking on paraocular area well-developed, occupying almost entire area except margins (Figure 122). (28) Genal marking streak-like, short. Mesosoma: (30) Transverse marking on pronotum absent; yellow spot on pronotal lobe vague or absent. (32) Scutum usually without yellow longitudinal lines. (35) Scutellum with two small yellow spots (sometimes only one). (38) Profemur dark brown with yellow apical spot at apex, extending basad on inner side for entire tibia length. (39) Protibia and mesotibia with yellow markings on outer sides extending for entire lengths of tibia. (40) Metatibia with yellow marking at base, extending for entire tibial length. (41) Protarsus and mesotarsus ferruginous, metatarsus yellow. (42) Metabasitarsus yellow. Metasoma: (43) Metasomal bands well-developed; T1 band often vague or absent, T2 and T3 bands usually interrupted medially, T4 and T5

bands unbroken, T6 band usually slightly interrupted medially, sometimes vague, no band on T7. However, there is some specimens that all bands are unbroken.

SPECIMENS EXAMINED IN ADDITION TO TYPE.—29 (16♀, 13♂).

JAPAN. Hokkaido: Hokodate, Akagawa, 20 May 1960, M. Munakata (2♂; **SAPPORO-SHIOKAWA**), 27 May 1960, M. Munakata (1♀, 1♂; **SAPPORO -SHIOKAWA**), 10 June 1960, M. Munakata (1♂; **SAPPORO -SHIOKAWA**), 26 June 1960, M. Munakata (1♂; **SAPPORO -SHIOKAWA**), 1 July 1960, M. Munakata (1♀; **SAPPORO -SHIOKAWA**), 2 September 1960, M. Munakata (1♀; **SAPPORO -SHIOKAWA**), 10 September 1960, M. Munakata (1♀; **SAPPORO -SHIOKAWA**), 30 September 1960, M. Munakata (1♀; **SAPPORO -SHIOKAWA**); Jozankei, 6 June 1964, M. Shiokawa (2♂; **SAPPORO -SHIOKAWA**); Misumai, 12 May 1966, M. Shiokawa (2♀; **SAPPORO -SHIOKAWA**), 20 May 1976, M. Shiokawa (1♀; **SAPPORO -SHIOKAWA**), Miyanomori, 21 May 1974, M. Shiokawa (1♂; **SAPPORO -SHIOKAWA**); Mt. Moiwa, 24 June 1964, T. Matsumura (2♀, 2♂; **SAPPORO -SHIOKAWA**), Sapporo, Bankei, 19 May 1964, T. Matsumura (2♀; **SAPPORO -SHIOKAWA**), 13 April 1964, T. Matsumura (1♀; **SAPPORO -SHIOKAWA**); Sapporo (in Japanese), 11 May 1972, Kawano Moiwa (2♂; **LAWRENCE**), 3 June 1972, Kawano Moiwa (1♀; **LAWRENCE**). Honshu: Fukusada, near Hyonosen, Hyogo Prefecture, 28 July 1977, 500 m, D.E. Boufford (1♀; **LAWRENCE**).

SOUTH KOREA: Suwon: Mt. Yoegi, 22 April 1998, Seung-Hwan Lee (1♀; **SEOUL**).

Ulsan Eonyang: VI. Baena, 27 May 1998, Seung-Hwan Lee (1♂; **SEOUL**).

Ceratina jejuensis S. Lee

FIGURE 24, 60, 94, 123 (see Figure section at the end of text)

Ceratina jejuensis S. Lee, 2005: 137–146, fig. 1–13 [male and female].

TYPE MATERIAL.—The male holotype in the Seoul National University, South Korea, **SEOUL** (not seen), is labeled “KOREA: JJ Bugjeju, Jocheon Seonheul, 17 July 1997, Seung-Hwan Lee”. Two paratypes in same institution as the holotype were examined. The female paratype is labeled “KOREA: JJ Bugjeju, Jocheon Seonheul, 17 April 1998, Seung-Hwan Lee” and “*Ceratina (Ceratinidia) jejuensis* S. Lee (♀) Det. S. H. Lee 2005”. The male paratype from the same location as the holotype is labeled “*Ceratina (Ceratinidia) jejuensis* S. Lee (♂) Det. S. H. Lee 2005”. Both paratypes are in excellent condition.

DISTRIBUTION.—*Ceratina jejuensis* is only known from Jeju Island, South Korea.

DIAGNOSIS AND COMPARATIVE COMMENTS.—*Ceratina jejuensis* is similar to *C. flavipes* in its punctation and maculation; however, the female *C. jejuensis* has bright longitudinal lines on the scutum and the markings on the metasomal terga are well-

developed and unbroken. *Ceratina takasagona* is also similar to *C. jejuensis*, but the facial maculation (clypeus, paraocular area, frontal spot, and supraclypeal spot) and the marking on T1 of *C. jejuensis* are more consistent with that of *C. flavipes* than with *C. takasagona*. The apical lobe on S6 of male *C. jejuensis* is angulate compared to a smooth apical lobe on S6 in male of *C. flavipes*. The marking on the clypeus in the male *C. flavipes* occupies the entire area, but in male *C. jejuensis* the upper lobe of the marking is triangular and does not reach the upper margin of the clypeus.

DESCRIPTION—**Female:** *Structure:* (1) Length 7.80 mm. Prosoma: (2) Clypeus rugose; small to coarse punctures along margin and median area, mostly on upper, upper lateral, and lower parts; median longitudinal carina present. (3) Labrum with dense medium-sized punctures, and with some bristles. (4) Paraocular area below antennal fossa shiny with few scattered small to medium-sized punctures. (5) Inner part of antennal fossa with sparse medium-sized punctures along frontal carina, outer part impunctate. (6) Dorsolateral area above antennal fossa without small smooth fovea. (7) Supraclypeal area below frontal carina with 1–2 punctures. (8) Frons with clumps of punctures scattered throughout; vertex with fairly dense course punctures. (9) Space between ocelli and upper part of compound eye with few punctures. (10) Genal area shiny almost impunctate. (11) Preoccipital carina not prominent; area behind ocelli slightly depressed. (12) Hypostomal area with scattered small punctures. Mesosoma: (13) Anterior fourth to third of scutum fairly densely and finely punctate; posterior two thirds to three fourths densely punctured; along

anteromedian line with at least one row of punctures; few or row of punctures along parapsidal furrow. (14) Lateral margin of scutum lined with one or two rows of small punctures. (15) Procoxa with rounded angle on outer side at base. (16) Mesepisternum with slightly dense medium-sized punctures laterally and less dense posterolaterally near mesocoxal base, ventral side with dense fine puncture; large impunctate area on hypoepimeral area; mesepisternum with dense long bristles. (17) Area around scrobe with large conspicuous impunctate area. (18) Propodeal triangle finely coriaceous-reticulate; lateral area of propodeum densely and finely punctate, without patch of dense hair anteriorly. Metasoma: (19)–(21) See male. *Maculations* (yellow except as noted): Prosoma: (22) Upper lobe of inverted-T marking on clypeus absent; lateral arm well-developed. (23) Labrum black. (24) Mandible black. (25) Supraclypeal spot well-developed. (26) Frontal spot near frontal carina present. (27) Marking on paraocular area linear, slightly interrupted medially, curved inward on lower part (hook-like); however (Figure 24). (28) Genal marking streak-like, extending for half of compound eye length. (29) Base of antennal scape black. Mesosoma: (30) Transverse marking on pronotum interrupted medially, not connected to yellow spot on pronotal lobe. (31) Spot behind pronotal lobe absent. (32) Scutum usually with four yellow longitudinal lines. (33) Axilla black. (34) Tegula reddish brown. (35) Scutellum with triangular marking. (36) Marking on metanotum absent. (37) Protrochanter and mesotrochanter with markings apically (mesotrochanter marking vague). (38) Profemur dark brown with small yellow spot at apex. (39) Protibia and mesotibia ferruginous with yellow markings on outer sides

extending for entire lengths of tibiae. (40) Metatibia dark brown with small yellow spot at base. (41) Tarsi dark brown. (42) Metabasitarsus dark brown. Metasoma: (43) Metasomal bands narrow but unbroken, except T2 band interrupted medially, no band on T6.

Male: As described for female except as follows: *Structure*: (1) Length 6.70 mm.

Prosoma: (2) Clypeus smooth; median longitudinal carina absent. (3) Labrum smooth with few scattered small punctures. (4) Paraocular area below antennal fossa smooth with scattered shallow, small punctures. (5) Inner part of antennal fossa with scattered medium-sized punctures along frontal carina, outer part impunctate. (7) Supraclypeal area below frontal carina impunctate. (8) Frons with small clump of small punctures and scattered long bristles; vertex with fairly dense coarse punctures and scattered long bristles. (12) Hypostomal area almost impunctate. Mesosoma: (13) Punctuation on scutum as in female but with more bristles. Metanotum: (19) S6 with long submedian teeth (three times longer than wide) on subapical depression; anterior part of S6 with medium-sized and dense punctures and stiff long bristles (no bristles near tooth); apical lobe angulate and prominent. (20) T7 apically pointed; margin between that point and lateral angle concave. (21) Genitalic structure not examined (also, not mentioned in Lee et al., 2005). *Maculations* (yellow except as noted): Prosoma: (22) Inverted-T marking on clypeus well-developed, occupying almost entire upper area. (23) Labrum with large yellow marking. (24) Mandible black with yellow marking basally and apically. (25) Supraclypeal spot well-

developed. (26) Frontal spot near frontal carina absent. (27) Marking on paraocular area well-developed, occupying almost entire area except margins (Figure 123). (28) Genal marking vague, almost absent. (29) Base and apex of antennal scape yellow. Mesosoma: (30) Transverse marking on pronotum absent (32) Scutum without yellow longitudinal lines. (33) Axilla black. (34) Tegula often reddish brown. (35) Scutellum marking often absent. (36) Marking on metanotum absent. (38) Profemur dark brown with yellow spots at apex on both inner and outer sides; marking on inner side extended basally for entire length of tibia. (39) Protibia and mesotibia ferruginous with yellow marking on outer side extending for entire length of tibia. (40) Metatibia ferruginous with yellow marking on outer side extending for entire length of tibia. (41) Tarsi ferruginous to yellow. (42) Meso- and metabasitarsus yellow. Metasoma: (43) Metasomal bands more reduced than in female; T1 band vague, T2–T5 bands broadly interrupted medially, no band on T6 and T7.

***Ceratina lepida* Smith**

FIGURE 19, 56, 90, 119, 148, 174 (see Figure section at the end of text)

Ceratina hieroglyphica Smith, 1854: 226 [female and male descriptions, part (North India specimen)]; Bingham, 1897: 503 [redescription of female and male]; Baker, 2002a: 359, fig. 1, 2, 11, and 13 [Baker erroneously selected Smith's original specimen from "N Ind" as the lectotype for *C. hieroglyphica*].

Ceratina lepida Smith, 1879: 92 [description of male]; Bingham, 1897: 505

[redescription of male and description of female]; van der Vecht, 1952: 50

[notes on type of *C. lepida*].

Ceratina coptica Baker, 2002a; 367, fig. 10 [Baker erroneously designated a *C.*

lepida specimen from Kashmir as one of *C. coptica* paratypes].

TYPE MATERIAL.—The male lectotype of *C. lepida* in the Natural History Museum, **LONDON**, is labeled “N. Ind. // ⁵⁵₇₆”, “B.M. Type Hym. 17 b 202”. The lectotype is in good condition. According to the Accession Register of the Natural History Museum, the male lectotype was obtained 6 November 1855, collected by Captain Reid and bought from Stevens.

Baker (2002a) selected one of the specimens, originally recognized by Smith (1854) as *C. hieroglyphica* from northern India, to be the lectotype of the name *C. hieroglyphica*. The female lectotype of *C. hieroglyphica sensu* Baker in the Natural History Museum, **LONDON**, is labeled “N. India // ⁴⁸₁₃₂”, “B.M. Type Hym. 17 a 2643a”, and “Type ♀ *Ceratina hieroglyphica* Smith, 1854: this is a large and macrocephalic ♀ of the species of which *C. lepida* Smith, 1879, represent a darker form from more eastern localities”. However, Baker’s action was invalid since the lectotype for the name *C. hieroglyphica* had already been selected by van der Vecht (1952). Baker’s *C. hieroglyphica* lectotype (female) from northern India is *C. lepida*.

DISTRIBUTION.—*Ceratina lepida* is known from northern India and Nepal (e.g., Himalchal Pradesh, Uttar Pradesh, Assam, Kathmandu Valley).

DIAGNOSIS AND COMPARATIVE COMMENTS.—The female and male of *C. lepida* can be distinguished easily from other *Ceratinidia* species by the pattern of punctation on the paraocular area, where fine to coarse punctures are clumped together on median part, and only few punctures present on lower and upper parts; and by the conspicuous median longitudinal impressed area on clypeus. *Ceratina lepida* closely resembles to *C. bryanti*, but can be distinguished from the latter (in both sexes) by the sparse punctation on the anterior portion of scutum (interspaces broader than puncture diameter or more); by the absence of a yellow spot on the profemur (in female); and by the absence of yellow marking on the metatibia (in female). The median projection between two submedian teeth on the subapical depression of the sixth sternum of the male *C. lepida* has a median incision, sometimes dividing the projection into two small pieces; whereas in male *C. bryanti*, the median projection is without a median incision.

DESCRIPTION—**Female:** *Structure:* (1) Length 6.90–8.75 mm. Prosoma: (2) Clypeus with median longitudinal impressed area; dorsal and dorsolateral area of clypeus with dense medium-sized punctures; median and lower parts of clypeus smooth or slightly rugose with few scattered shallow punctures; median longitudinal carina vague. (3) Labrum with mixture of medium-sized and coarse punctures and with many short

bristles. (4) Paraocular area below antennal fossa with dense, small to coarse punctures, clumped together on middle part, few punctures on lower part. (5) Inner part of antennal fossa with coarse punctures along frontal carina, outer part impunctate or with few punctures. (6) Dorsolateral area of antennal fossa without conspicuous smooth fovea. (7) Supraclypeal area below frontal carina with 1–2 punctures and ventral depression. (8) Frons and vertex with dense and coarse punctures. (9) Space between ocelli and upper part of compound eye with few scattered coarse punctures. (10) Gena shiny, almost impunctate. (11) Preoccipital carina not prominent; area behind ocelli slightly depressed. (12) Hypostomal area with few scattered medium-sized punctures; hypostomal carina slightly prominent.

Mesosoma: (13) Anterior third of scutum sparsely punctate (interspaces broader than puncture diameter or more); posterior two thirds of scutum shiny and impunctate except posteriorly; one row of punctures on each side of anteromedian line. (14) Lateral margin of scutum lined with two or more rows of small fine punctures. (15) Procoxa with round angle on outer side at base. (16) Mesepisternum with dense coarse punctures laterally and ventrally; punctures slightly less dense posterolaterally near mesocoxal base. (17) Scrobal area with small conspicuous oblique impunctate area. (18) Propodeal triangle finely coriaceous-reticulate; lateral area of propodeum densely and finely punctate, without patch of dense hair anteriorly. Metasoma (19)–(21) See male. *Maculations* (yellow except as noted): Prosoma: (22) Upper lobe of inverted-T marking of clypeus reaching half of clypeal length or more; lateral arm of marking with small hook pointed downward. (23) Labrum black. (24) Mandible

black. (25) Supraclypeal spot well-developed. (26) Frontal spot oval, well-developed. (27) Marking on paraocular area thick linear and hooked inward along lower margin (Figure 19). (28) Genal marking slightly narrowed downward; extending 2/3 of eye length. (29) Base of antennal scape black. Mesosoma: (30) Transverse marking on pronotum rarely connected to yellow spot on pronotal lobe. (31) Spot behind pronotal lobe absent. (32) Scutum with four longitudinal lines. (33) Axilla black. (34) Tegula reddish-brown translucent. (35) Scutellum with more or less rectangular marking narrowed posteriorly; small incision on anterior margin of marking. (36) Marking on metanotum absent. (37) Protrochanter with small marking on outer side apically (sometimes absent); mesotrochanter black. (38) Profemur often black (sometimes with two small yellow spots on inner and outer sides of femur). (39) Protibia with yellow marking on outer side extending distally for half of tibia length; mesotibia black. (40) Metatibia with yellow spot at base. (41) Tarsi dark brown to black. (42) Metabasitarsus black. Metasoma: (43) Metasomal bands well developed and unbroken; no band on T6; T1 with wide marking not enclosing two black spots.

Male: As described for female except as follows: *Structure*: (1) Length 8.65–8.70 mm. Prosoma: (2) Clypeal area less punctured and median longitudinal impressed area not as prominent as in female. (3) Labrum with mixture of small and medium-sized punctures. Mesosoma: (13) Anterior portion of scutum with more punctures along parapsidal furrow. (18) Propodeal triangle finely coriaceo-reticulate,

reticulated matt zone on basal area more prominent than in female; lateral area of propodeum densely and finely punctate, without patch of dense hair on anterior part.

Metasoma: (19) S6 with two medium-sized submedian teeth and small median projection on subapical depression; median projection with median incision, sometimes divided into two small pieces (Figure 148); anterior part of S6 with medium-sized and dense punctures and stiff long bristles (no bristles near tooth area); apical lobe prominent. (20) T7 apically pointed; lateral angle of T7 angulate. (21) Distal part of gonocoxite broad at apex, with bristles along apical margin; inner margin of gonocoxite rounded with small protrusion. *Maculations* (yellow except as noted): Prosoma: (22) Upper lobe of inverted-T marking on clypeus reaching 2/3 of clypeal length, dorsal and dorsolateral area without marking; lower part of marking occupying almost entire area. (25) Supraclypeal spot more reduced than in female. (26) Frontal spot reduced to small spot or absent. (27) Marking on paraocular area linear above, abruptly widened below (Figure 119). (28) Lateral genal marking slightly narrowed downward; extending half of eye length. Mesosoma: (30) Transverse marking on pronotum usually absent or small remnant; pronotal lobe black. (32) Scutum with two vague outer lines. (35) Scutellum with two small yellow spots. (38) Profemur black. (39) Protibia black with yellow marking on outer side extending distally from base for 2/3 of tibial length; mesotibia sometimes with small yellow spot. (40) Metatibia with yellow spot at base, extending for 2/3 of tibial length. (41) Tarsi black. (42) Metabasitarsus black. Metasoma: (43) Metasomal bands more reduced than in female; on T1 vague, almost absent, T2 and T3 with

bands broadly interrupted medially, T4 and T5 with bands slightly interrupted medially (sometimes unbroken), no band on T6.

SPECIMENS EXAMINED IN ADDITION TO TYPES.—16 (14♀, 2♂).

INDIA. Assam: Kohora, Kasiranga, 80 m, 29 April 1985, K. Ghorpada (1♀; **LAWRENCE**). Himachal Pradesh: Kulu, 1,200 m, 29 April 1990, L. Packer (1♀; **LAWRENCE-BAKER**); Tattapani, 600 m, 8 March 1990, L. Packer (1♀; **LAWRENCE-BAKER**). Uttar Pradesh: Chamoli, 1,100 m, 19 August 1990, S. A. Cameron (1♀; **LAWRENCE**); Garhwal Himalaya, F. R. H. Uttarkashi, 1,300 m, 18 August 1990, S. W. T. Batra (1♀, 1♂; **LAWRENCE**), 28–29 April 1995, S. W. T. Batra (2♀; **LAWRENCE**); Mussoorie, Kempt Falls, 4,000 m, 16 October 1964, S. W. T. Batra (1♀; **LAWRENCE**), 25 June 1965, S. W. T. Batra (1♀; **LAWRENCE**), 27 June 1965, S. W. T. Batra (2♀; **LAWRENCE**).

NEPAL. Kathmandu Valley: Gokarna Forest, 4,500 ft, 2 September 1969, C. G. Roche (1♀, 1♂; **LAWRENCE-BAKER**); Maharajganj, 4,500 ft, 25 August 1969, C. G. Roche (1♀; **LAWRENCE-BAKER**); Swayambhu Nath, 4,500 ft, 27 August 1969, C. G. Roche (1♀; **LAWRENCE-BAKER**).

Ceratina lieftincki van der Vecht

FIGURE 25, 61, 95, 124, 151, 177 (see Figure section at the end of text)

Ceratina lieftincki van der Vecht, 1952: 73–74 [male and female]

TYPE MATERIAL.— The male holotype of *C. lieftincki* in the Nationaal Natuurhistorisch Museum, **LEIDEN** (not seen), is labeled “Djasinga, 150 m., Tjibarangbang, 15 Nov. 1936, resp. E. v. d. Vecht-B. and J. v. d. Vecht”. The female paratype in the same institution as the holotype, is labeled “W. Java Buitenzorg Mt. Tjiampea, 14 January 1944, J. v. d. Vecht”. The paratype is in fair condition; one flagellum is missing, and one hind leg is missing from femur to tarsus.

DISTRIBUTION.—*Ceratina lieftincki* has a wide range in South East Asia, from the Philippines (Palawan Island) to Indonesia, Malay peninsula, and Indochina.

DIAGNOSIS AND COMPARATIVE COMMENTS.—*Ceratina lieftincki* is similar to *C. compacta*, but can be distinguished from the latter by the absence of yellow marking on the base of the antennal scape and by the sparsely punctate (interspaces broader than puncture diameter) posterolateral area of the mesepisternum near the mesocoxal base.

DESCRIPTION—**Female:** *Structure:* (1) Length 6.75–9.95 mm. Prosoma: (2) Clypeus smooth with shallow scattered punctures near upper margin, few punctures on lower margin; median area impunctate; longitudinal median carina vague (sometimes absent). (3) Labrum slightly wrinkled with some coarse punctures, and with short scattered setae. (4) Paraocular area below antennal fossa with few shallow scattered

ill-defined punctures. (5) Inner part of antennal fossa with medium-sized punctures along frontal carina (less dense than in *C. compacta*), outer part impunctate or at most with 1–2 shallow punctures. (6) Dorsolateral margin of antennal fossa without distinct smooth fovea. (7) Supraclypeal area below frontal carina more or less impunctate with ventral depression. (8) Frons impunctate in lower part of antennal fossa area, but with scattered coarse punctures in upper part, and through out vertex (not as dense as in *C. compacta*). (9) Space between ocelli and upper part of compound eye impunctate. (10) Genal area with few shallow scattered punctures. (11) Preoccipital carina not prominent; area behind ocelli slightly depressed. (12) Hypostomal area with scattered punctures except lower part. Mesosoma: (13) Anterior portion of scutum with dense medium-sized punctures occupying almost half of scutum; small area between anteromedian line and parapsidal furrow and small area around parapsidal furrows impunctate (except outer side of parapsidal furrow with two or more rows of punctures); one or two rows of punctures along median line; dense punctures on posterior part of scutum before scuto-scutellar sulcus. (14) Lateral margin of scutum lined with one row of medium-sized punctures. (15) Procoxa with round angle on outer side at base. (16) Mesepisternum with dense coarse punctures; scattered punctures on posterolateral area near mesocoxal base and on ventrally (finely punctate in Thai specimens). (17) Area around scrobe with conspicuous impunctate area. (18) Propodeal triangle finely coriaceo-reticulate; lateral area of propodeum densely and finely punctate; with or with out small patch of dense hair anteriorly. Metasoma: (19)–(21) See male. *Maculations* (yellow except as

noted): Prosoma: (22) Inverted-T marking on clypeus well-developed, with small hook-like point downward on lateral arm. (23) Labrum black without yellow spot (sometimes with vague spot). (24) Mandible black. (25) Supraclypeal spot well-developed, but without upper median point. (26) Frontal spot well-developed. (27) Marking on paraocular area gradually widened from top to bottom (Figure 25.) (28) Genal marking slightly narrowed downward, extending half to 2/3 of eye length. (29) Base of antennal scape reddish brown to black. Mesosoma: (30) Transverse marking on pronotum well connected to yellow spot on pronotal lobe. (31) Spot behind pronotal lobe present (absent in one specimen from Palawan, Philippines). (32) Scutum with four longitudinal lines. (33) Axilla black. (34) Tegula reddish-brown translucent. (35) Scutellum with large marking occupying entire area, except anterior part; small incision on anterior margin of marking. (36) Marking on metanotum absent. (37) Marking on apices of protrochanter and mesotrochanter usually absent or at most vague. (38) Apex of profemur with yellow band extending basad on inner side for 2/3 of femoral length. (39) Markings on outer side of protibia and mesotibia extending almost entire lengths. (40) Metatibia with yellow marking at base extending distad for 1/2 of tibial length. (41) Tarsi reddish brown to black. (42) Metabasitarsus reddish brown to black. Metasoma: (43) Metasomal bands well developed and unbroken (except T3 and sometimes T4 bands interrupted), no band on T6; T1 with wide marking enclosing two small black spots.

Male: As described for female except as follows: *Structure:* (1) Length 6.50–8.60 mm. Prosoma: (3) Labrum slightly wrinkled with some coarse punctures, and with short scattered setae. (4) Paraocular area below antennal fossa with few scattered punctures (more punctures than in female). (6) Dorsolateral margin of antennal fossa with small smooth fovea. (10) Genal area with few shallow scattered punctures (most on ventral side). (12) Hypostomal area with scattered punctures mostly on posterior part. Mesosoma: (13) Anterior part of scutum with denser punctures, and more punctures around parapsidal furrow (except in one specimen from Java). (14) Lateral margin of scutum lined with two or more rows of medium-sized punctures. (17) Area around scrobe with small conspicuous impunctate area. Metasoma: (19) S6 with V-shaped ridge, with small lateral tooth on each side of ridge on subapical depression (Figure 151); anterior part of S6 with coarse and dense punctures and stiff long bristles (no bristles near ridge); apical lobe not prominent. (20) T7 apically pointed and with slightly round edges. (21) Distal part of gonocoxite slightly narrowed, with bristles along apical margin; inner margin of gonocoxite rounded. *Maculations:* Prosoma: (22) Inverted-T marking on clypeus well-developed occupying almost entire area except margin; upper margin of marking pointed (sometimes blunted). (23) Labrum with yellow spot (sometimes vague). (26) Frontal spot linear (smaller than in female). Mesosoma: (31) Spot behind pronotal lobe present (absent in one specimen from Java). (31) Marking on metanotum absent (some specimens from Thailand with vague yellow). (38) Apex of profemur with yellow band extending basad on inner side, occupying almost entire length of femur. (39) Marking present

on outer sides of protibia and mesotibia, extending almost entire lengths. (40)
Metatibia with yellow marking at base extending distad almost entire length of tibia.
(41) Tarsi reddish brown to black (with some segments yellow). (42) Metabasisarsus
from dark brown to yellow. Metasoma: (43) Metasomal bands well developed and
unbroken (T3 and sometimes T4 bands interrupted); no band on T7; T1 with wide
marking enclosing two small black spots.

SPECIMENS EXAMINED IN ADDITION TO TYPES.—53(36♀, 17♂).

CAMBODIA. Siem Reap: 11 March 1968, M.D. Delfinado (1♀; **HONOLULU**)

INDONESIA. Java: Boyolali, 10 May 1973, 450 m, C.D. Michener (1♂;

LAWRENCE)

LAOS. Pon-Hom: N. of Pakkading, 20 April 1965, J.L. Gressitt (1♀; **HONOLULU**).

Savannakhet: Savannakhet, 15 April 1967, Native Collector (1♂; **HONOLULU**).

Sayaboury: 13 April 1966, Native Collector (1♂; **HONOLULU**).

MALAYSIA. Johor: 15 km S. of Endau, 1 July 1983, Edward S. Ross (1♀; **SAN FRANCISCO**); 15.3 km W. of Sedili Besar, 16 October 1986, John W. Wenzel (1♀;

LAWRENCE). Negeri Sembilan: Tassek Bera, Bahau, 17 October 2975, R. Jander (1♀; **LAWRENCE**). Selangor: Ampang, E. of Kuala Lumpur, 3 June 1973, C.D.

Michener (1♀, 6♂; **LAWRENCE**), 4 August 1973, Phang Ong Wah (5♀;

LAWRENCE), 30 September, Phang Ong Wah (2♂; **LAWRENCE**); Kuala Lumpur, 1 September 1926, H.M. Pendlebury (1♂; **BERLIN**); 24–31 December 1958, L.W. Quate (1♂; **HONOLULU**).

PHILIPPINES. Palawan: Aborlan P.N.A.C, 23 April 1992, S.G. Reyes (1♀; **LAWRENCE**)

THAILAND. Bangkok: 24 September 1969, Pensri (in Thai) (1♂; **BANGKOK**), 6 May 1973, P.S. Messenger (1♀; **CAS**); Chulalongkorn University, 23 August 1999, Sonthaya (in Thai) (1♀; **BANGKOK**). Chiang Mai: Chiang Mai University, 6 August 1988, Pornthep (in Thai) (1♀; **CHIANG MAI**); Mae Rim, 29 January 1994, R.A. Beaver (1♀; **LOS ANGELES**), 26 January 1995, R.A. Beaver (1♀; **LOS ANGELES**); Mae Wang, Don Pao, Pa Huay Kho, 1–10 April 1997, 18°69'N 98°81'E, Saowapa Sonthichai (2♀; **LOS ANGELES**), 10–20 April 1997, 18°69'N 98°81'E, Saowapa Sonthichai (2♀; **LOS ANGELES**), 20–30 April 1997, 250 m, 18°41'N 98°48'E, Saowapa Sonthichai (5♀; **LOS ANGELES**). Kanchanaburi: 110 air km. W. of Bangkok, 25–27 April 1988, W.J. Pulawski (1♀; **SAN FRANCISCO**); 10 April 1989, W.J. Pulawski (1♀; **SAN FRANCISCO**). Loei: 24 April 1989, W.J. Pulawski (1♀; **SAN FRANCISCO**). Nakhon Nayok: Nakhon Nayok, 21 January 1993, S. Boongird and C.D. Michener (2♀, 1♂; **LAWRENCE**). Nakhon Ratchasima: Burerum, 20 April 1993, 163 m, Jarunya Thummanu (1♀; **LAWRENCE**), 15 May 1993, 163 m, Jarunya Thummanu (1♀; **LAWRENCE**); Pak Chang, 11 February 1993, S. Boongird and C.D.

Michener (1♀; **LAWRENCE**). Prajinburi: Kabinburi, Bankhun Si, 5 December 1965,
Kol Mongkolpanya (1♀; **NEW YORK**). Rayong: Ko Samet, 5–7 May 1989, W.J.
Pulawski (2♂; **SAN FRANCISCO**). Trang: Khao Chong Nature Education Centre, 21–
24 July 1996, 7°35'N 99°46'E, Snelling and Sonthichai (1♀; **LOS ANGELES**).

Ceratina litoraria van der Vecht

FIGURE 26, 62, 96, 125, 152, 178 (see Figure section at the end of text)

Ceratina litoraria van der Vecht, 1952: 59–61 [Female and male.]

TYPE MATERIAL.—The female holotype of *C. litoraria* in the Nationaal
Nuurhistorisch Museum, The Netherlands, **LEIDEN** (not seen), is labeled, according
to van der Vecht (1952), “West Java, Malingping at South coast of Banten, 22–24
March 1940, J. v. d. Vecht”. The male paratype of *C. litoraria* in the same institution
as the holotype is labeled “W. Java, 600 m., Djampang Tengah 16 February 1941,
Lieftinck” and “Museum Leiden ex coll. M. A. Lieftinck”. The paratype is in good
condition with a strong trituberculate marking on the supraclypeal area. The
localities of the holotype and the paratype are in the same area (West Java, van der
Vecht, 1952).

DISTRIBUTION.—*Ceratina litoraria* is known from the Islands of Indonesia including
Flores, Java, Kangean, Komodo, Krakatua, and Sumatra

DIAGNOSIS AND COMPARATIVE COMMENTS.—*Ceratina litoraria* is similar to *C. accusator* and *C. chiangmaiensis* in its small size and in markings, as well as the facial and scutal punctation. However, *C. litoraria* can be easily distinguished from the latter two by the dense punctation of the clypeus, paraocular area, frons, and vertex. The punctures in *C. litoraria* combine fine and coarse punctures, with interspaces between more or less smaller than puncture diameters. In some female specimens, the marking on supraclypeal area is trituberculate; while, in most males, the supraclypeal area is swollen, and hence more distinctly trituberculate.

S6 of the male *C. litoraria* was illustrated by van der Vecht (1952) to show no sign of a median tooth between the two lateral teeth on the subapical depression. However, I have dissected one male from Flores, and found that the median tooth is in fact present, and similar to that of *C. accusator*. However, the apical lobe of S6 in *C. litoraria* is more prominent than in *C. accusator*.

Ceratina litoraria from Komodo Island appears to be a dark form of this species. The two females from Komodo Island lack longitudinal lines on the scutum, the marking on the scutellum is reduced to two small spots, and the transverse band on the pronotum is interrupted medially and does not connect to the marking of the pronotal lobe.

DESCRIPTION—**Female:** *Structure:* (1) Length 5.75–7.20 mm. Prosoma: (2) Clypeus densely punctured with fine and coarse punctures, mostly on upper and upper lateral

region (punctures even on clypeal marking); lower part with few punctures; median longitudinal carina present (sometime vague). (3) Labrum with scattered medium-sized punctures, and short setae. (4) Paraocular area below antennal fossa with dense medium-sized punctures throughout, few on lower part. (5) Inner part of antennal fossa with dense medium-sized punctures along frontal carina; outer part with scattered punctures, mostly in dorsolateral area. (6) Dorsolateral part of antennal fossa area without smooth fovea. (7) Supraclypeal area below frontal carina impunctate. (8) Frons and vertex with dense medium-sized punctures. (9) Space between ocelli and upper part of compound eye with slightly less dense medium-sized punctures than frons and vertex. (10) Gena shiny with scattered shallow punctures. (11) Preoccipital carina not prominent; area behind ocelli slightly depressed. (12) Hypostomal area with few small punctures. Mesosoma: (13) Anterior third of scutum with medium-sized punctures; punctures forming triangle extending on anteromedian line and parapsidal furrow; posterior two thirds with dense punctures; one or two rows of punctures along anteromedian line; impunctate area between anteromedian line and parapsidal furrow (more punctures in smaller specimens). (14) Lateral margin of scutum lined with one or two rows of medium-sized punctures. (15) Procoxa slightly angulate on outer side at base. (16) Mesepisternum with dense medium-sized punctures laterally; punctures less dense ventrally and posterolaterally near mesocoxal base. (17) Area around scrobe with conspicuous impunctate area. (18) Propodeal triangle finely coriaceous-reticulate; lateral area of propodeum densely and finely punctate, with patch of dense hair anteriorly. Metasoma: (19)–(21) See

male. *Maculations* (yellow except as noted): Prosoma: (22) Upper lobe of inverted-T marking at most reaching half clypeal length; lateral arm with small hook-like projection pointed downward. (23) Labrum dark brown. (24) Mandible dark brown. (25) Supraclypeal spot well-developed; linear with slight median convexity (trituberculate). (26) Frontal spot well-developed. (27) Marking on paraocular area linear; lower part bent inward (hook-like) (Figure 26.) (28) Genal marking slightly narrowed downward; extending 2/3 of eye length. (29) Base of antennal scape ferruginous. Mesosoma: (30) Transverse marking on pronotum connected to yellow spot on pronotal lobe. (31) Spot behind pronotal lobe small. (32) Scutum with four longitudinal lines. (33) Axilla black. (34) Tegula reddish-brown translucent. (35) Scutellum with rectangular mark, slightly narrowed posteriorly; anterior margin with slight incision (in specimens with fewer facial punctures, marking reduced to small triangle). (36) Yellow marking on metanotum absent. (37) Protochanter and mesotrochanter each with small yellow marking apically. (38) Profemur with yellow spot on outer side at apex, extending basad for 2/3 of femoral length. (39) Protibia and mesotibia ferruginous, each with yellow marking on outer side extending almost entire tibial length (sometimes marking on mesotibia reaching only half of tibia length). (40) Metatibia with yellow spot at base, extending distally for half of tibia length. (41) Tarsi ferruginous. (42) Metabasitarsus ferruginous. Metasoma: (43) Metasomal bands well-developed; T1 band enclosing two black spots, T2 band sometimes interrupted medially, T3 band slightly interrupted medially; T4 and T5 bands unbroken, no band on T6 (in small specimens all band unbroken).

Male: As described for female except as follows: *Structure:* (1) Length 5.85–6.90 mm. Prosoma: (2) Punctuation on clypeus as in female; however, punctures more defined; median impressed area and median longitudinal carina prominent. (5) Inner part of antennal fossa with dense, medium-sized punctures along frontal carina; outer part with slightly less dense punctures. (7) Supraclypeal area below frontal carina with scattered punctured, usually prominent and noticeable. (8) Frons and vertex with dense medium-sized punctures (punctures more defined than in female). (9) Gena with scattered punctures. Mesosoma: (13) Scutum with more punctures along anteromedian line than in female; thus, reducing impunctate area. (14) Lateral margin of scutum lined with two or more rows of medium-sized punctures. (16) Mesepisternum with dense medium-sized punctures laterally and posterolaterally near mesocoxal base; punctures less dense ventrally. (17) Area around scrobe with less conspicuous impunctate area than in female. Metasoma: (19) S6 with submedian tooth and median denticle on subapical depression (Figure 152); anterior part of S6 with coarse punctures and bristles (no bristles near tooth area; bristles not dense); apical lobe prominent, somewhat fused laterally. (20) T7 apically rounded, slightly produced in middle. (21) Distal part of gonocoxite slightly broad, with bristles along apical margin; inner margin of gonocoxite slightly angulated. *Maculations* (yellow except as noted): Prosoma: (22) Marking on clypeus varies; sometimes lower margin of marking occupying entire area with small upper lobe, though some specimens lack upper lobe on the transverse marking. (23) Labrum marking absent or with large

yellow marking. (24) Mandible black, sometimes with small yellow spot. (26) Frontal spot absent. (27) Marking on paraocular area more reduced than in female (Figure 125.) (28) Genal marking short streak. (29) Base of antennal scape black. Mesosoma: (30) Transverse marking on pronotum, interrupted medially, not connected to yellow spot on pronotal lobe. (31) Spot behind pronotal lobe absent. (32) Scutum without longitudinal lines or with only two inner lines. (35) Scutellum with two small yellow spot or triangular marking. (38) Profemur with yellow spot on outer side at apex, extending basad for entire length of tibia. (39) Protibia ferruginous with yellow marking on outer side extending almost entire tibial length; mesotibia ferruginous with yellow spot on outer side at base. (40) Metatibia with yellow spot at base, sometimes extending for entire tibia length. (41) Tarsi ferruginous except metatarsi yellow. (42) Metabasitarsus yellow. Metasoma: (43) Metasomal bands more reduced than in female; T1 band not enclosing two black spots, T2, T3, and T4 bands slightly interrupted medially; T5 band unbroken, T6 with or without marking.

SPECIMENS EXAMINED IN ADDITION TO TYPES.—7 (6♀, 1♂).

INDONESIA. Flores: Moni Wolowaru, 11 November 1949, Bühler and Sutter (1♂; **LEIDEN**). Java: Batavia (Jakarta), November 1907, E. Jacobson (1♀; **LEIDEN**); Tandjong: June 1908, E. Jacobson (1♀; **LEIDEN**); West Java, Dungus Iwul, 100 m., 2 December 1952, M. A. Lieftinck ((1♀; **LEIDEN**)). Kangean Island: Petapan, February 1936, M. E. Walsh (1♀; **LEIDEN**). Komodo Island: June 1953, A. Hoogerwerf (2♀; **LEIDEN**).

Ceratina maai Shiokawa *Incertae Sedis*

Ceratina maai Shiokawa and Hirashima, 1982: 181–183, fig. 2–6 [male and female]

COMMENTS.—Shiokawa and Hirashima (1982) proposed a species, *C. maai*, from Fukien, China, said to be closely related to *C. flavipes*. The holotype of *C. maai* was said to be deposited at the Bishop Museum, **HONOLULU**, but none of the museum staff can locate it (Al Samuelson pers. comm.). The authors of this name indicated the diagnostic characters are only in the male, and illustrated the maculation of the female as similar to *C. flavipes*. I have not examined any specimens bearing this name. *Ceratina maai* could be a synonym of *C. flavipes*, though I could not confirm or reject this possibility.

Ceratina malukuensis Warrit **new species**

FIGURE 27, 63, 97, 126, 153, 179 (see Figure section at the end of text)

TYPE MATERIAL.—The female holotype is deposited in the Nationaal Natuurhistorisch Museum, **LEIDEN**. It is in good condition and is labeled “N. Mollucas, 0 m., S. Batjan, June–July 1953, A. M. R. Wegner” and “Museum Leiden ex coll. M. A. Liefstinck”. Five paratypes are designated as follows: two female and one male paratypes from the type locality and one female paratype labeled “Moluccas 1953, NW. OBI, September–October, Laiwui 0–200 m, A. M. R. Wegner” and “Museum

Leiden ex coll. M. A. Lieftinck” are deposited in the Nationaal Natuurhistorisch Museum, **LEIDEN**. One female paratype from the type locality is deposited at the University of Kansas Natural History Museum and Biodiversity Research Center, **LAWRENCE**.

ETYMOLOGY.—This species is named after the type locality in Northern Maluku Islands (Moluccas) of Indonesia, where the species appears to be endemic.

DISTRIBUTION.—*Ceratina malukuensis* is only known from Batjan and Obi Islands in the Northern Maluku (Moluccas), Indonesia.

DIAGNOSIS AND COMPARATIVE COMMENTS.—*Ceratina malukuensis* is similar to *C. interrupta*. The deep incision on the upper lobe of the marking on the clypeus is a good character to differentiate *C. malukuensis* and *C. interrupta* from other *Ceratinidia*. In the female, *C. malukuensis* can be distinguished from *C. interrupta* by the absence of dense coarse punctures on genal and hypostomal areas. The punctures on the gena and hypostomal are present in males of both *C. malukuensis* and *C. interrupta*, but the punctures in male *C. interrupta* are denser (although interspaces broader than puncture diameters) than in *C. malukuensis*. Genitalic structure, S6, and T7 are similar in *C. malukuensis* and *C. interrupta*.

The only male considered to belong to *C. malukuensis* has the upper part of the gena coarsely punctate, thus approaching *C. interrupta*. In the absence of more

specimens, the possibility exists that it is a male of *C. interrupta* and that the male of *C. malukuensis* is unknown.

DESCRIPTION—**Female:** *Structure:* (1) Length 8.35–8.90 mm. Prosoma: (2) Clypeus smooth; lateral and upper area with scattered small punctures; median area impunctate without broad depressed area; median longitudinal carina vague (sometimes absent); lower part of clypeus with few punctures. (3) Labrum with mixture of small and medium-sized punctures, with some long bristles. (4) Paraocular area below antennal fossa smooth with scattered small shallow punctures. (5) Inner part of antennal fossa with dense coarse punctures along frontal carina, outer part impunctate, at most with 1–2 punctures. (6) Dorsolateral part of antennal fossa area without small smooth fovea. (7) Supraclypeal area below frontal carina impunctate and depressed ventrally. (8) Frons and vertex with dense coarse punctures above antennal fossa. (9) Space between ocelli and upper part of compound eye with fairly dense coarse punctures. (10) Genal area almost impunctate with few shallow punctures. (11) Preoccipital carina not prominent; area behind ocelli slightly depressed. (12) Hypostomal area with few shallow punctured.

Mesosoma: (13) Anterior portion of scutum with dense medium-sized punctures extending posteriorly along lateral margin; posterior area with dense punctures; area between two parapsidal furrows impunctate with scattered punctures along parapsidal furrow and anteromedian line. (14) Lateral margin of scutum lined with one or two rows of coarse punctures. (15) Procoxa slightly angulate on outer side at base

(sometimes blunted). (16) Mesepisternum with dense medium-sized punctures laterally, coarse punctures but slightly less dense on ventral side and posterolaterally near coxal base. (17) Area around scrobe with conspicuous impunctate area. (18) Propodeal triangle finely coriaceous-reticulate; lateral area of propodeum densely and finely punctate, with small patch of dense hair anteriorly. Metasoma: (19)–(21) See male. *Maculations* (yellow except as noted): Prosoma: (22) Upper lobe of inverted-T marking on clypeus with deep incision on upper margin (at least 1/3 of clypeal length); lateral arms with small hook pointed downward. (23) Labrum black. (24) Mandible black. (25) Supraclypeal area convex medially and more or less narrow. (26) Frontal spot narrow. (27) Marking on paraocular area narrow nearly straight, lower part slightly bent inward and almost horizontal (Figure 27). (28) Genal marking slightly narrowed downward; extending half to 2/3 of eye length. (29) Base of antennal scape ferruginous to black. Mesosoma: (30) Transverse marking on pronotum rarely connected to yellow spot on pronotal lobe. (31) Spot behind pronotal lobe small. (32) Scutum with four vague longitudinal lines (sometimes inner lines absent). (33) Axilla black. (34) Tegula dark reddish-brown translucent. (35) Scutellum with rectangular marking, narrowed posteriorly; small incision in anterior margin of marking. (36) Marking on metanotum absent. (37) Protrochanter with marking apically; mesotrochanter with vague marking apically. (38) Profemur dark brown with yellow spots at apex, extending basad on inner side at most half of femoral length. (39) Protibia and mesotibia dark brown with yellow markings on outer sides extending almost entire tibial lengths. (40) Metatibia dark brown with

small yellow spot at base extending distally at most half of tibia length. (41) Tarsi ferruginous to dark brown. (42) Metabasitarsus dark brown. Metasoma: (43) Metasomal bands well-developed; T1 band often enclosing two small spots, T2 and T3 bands often broadly interrupted medially, T4 band sometimes interrupted medially, T5 band unbroken, no band on T6.

Male: As described for female except as follows: *Structure*: (1) Length 7.90 mm.

Prosoma: (3) Labrum with mixture of small and medium-sized punctures, and with few short setae. (4) Paraocular area below antennal fossa with fairly dense small to medium-sized punctures (denser than in female). (5) Inner part of antennal fossa with dense coarse punctures along frontal carina, outer part with few punctures. (6)

Dorsolateral part of antennal fossa area with small smooth fovea. (7) Supraclypeal area below frontal carina with few small punctures, ventrally depressed. (10) Genal area with dense coarse puncture on upper part and scattered punctures on lower part.

Mesosoma: (13) Scutum densely punctate with medium-sized punctures, except small area between anteromedian line and parapsidal furrow. (14) Lateral margin of

scutum lined with two or more rows of coarse punctures. Metasoma: (19) S6 with V-shaped ridge on subapical depression, with two small denticles on each side of ridge (Figure 153); anterior part of S6 with fairly dense medium-sized punctures and sparse short bristles (no bristles near ridge or lateral margin); apical lobe not prominent.

(20) T7 apically truncate with small median emargination; lateral angle rounded. (21)

Distal part of gonocoxite of genitalia slightly narrowed, with bristles along apical

margin; inner margin of gonocoxite rounded. *Maculations* (yellow except as noted):
Prosoma: (22) Upper lobe of inverted-T marking with median incision on upper margin (not as deep as in female). (23) Labrum dark brown with yellow spot. (26) Frontal spot absent. (27) Marking on paraocular area linear, widened gradually from top to bottom (Figure 126). (28) Genal marking slightly narrowed downward; extending 1/4 of eye length. Mesosoma: (30) Transverse marking on pronotum barely connected to yellow spot on pronotal lobe. (31) Spot behind pronotal lobe absent. (32) Scutum without longitudinal lines. (35) Scutellum with more or less triangular marking; small incision in anterior margin of marking. (37) Protrochanter and mesotrochanter with markings apically. (38) Profemur dark brown with yellow spot at apex, extending basad on inner side for half of femoral length. (39) Protibia and mesotibia dark brown with yellow markings on outer sides extending almost entire tibial lengths. (40) Metatibia dark brown with small yellow spot at base extending distally for entire length of tibia. (41) Tarsi ferruginous to yellow. (42) Metabasisarsus yellow. Metasoma: (43) Metasomal bands well-developed; T1 band not enclosing two small black spots, T2 and T3 bands broadly interrupted medially, T4 band sometimes interrupted medially, T5 and T6 bands unbroken, no band on T7.

***Ceratina moderata* Cameron**

FIGURE 28, 64, 98, 127, 154, 180 (see Figure section at the end of text)

Ceratina moderata Cameron, 1897: 139 [male]; Bingham, 1897: 504 [erroneously stated Cameron's type to be female]; van der Vecht, 1952:81 [selected lectotype and provided additional description]; Baker, 2002a, 359, fig. 3 [indicated synonymy].

Ceratina ornatifera Cameron, 1897: 141 [female and male; however, they are not conspecific. Female characters agree well with *C. moderata*]; van der Vecht, 1952: 82 [selected lectotype, notes on lectotype].

Ceratina incognita Bingham, 1898: 127 [male].

TYPE MATERIAL.—The lectotype of *C. moderata* (male) is in the Hope Entomological Collection, Oxford University, **OXFORD**. The lectotype is labeled “*Ceratina moderata* Cam. Type” and “Mussoorie: Rothney”. In Cameron's original description, he did not indicate the sex and provided an incomplete and inaccurate description of this species. Van der Vecht (1952) selected one male labeled as *C. moderata* by Cameron as a lectotype, and provided additional description for species. However, van der Vecht erroneously grouped *C. moderata* in the compacta species-group based on the absence of two lateral teeth on the subapical depression of S6. Baker (2002a) pointed out that two lateral teeth on S6 are present, in fact large and distinct. I have also examined some other male specimens, and arrived at the same conclusion as Baker.

The lectotype of *C. ornatifera* in Hope Entomological Collection, Oxford University, **OXFORD**, is labeled “9” and “*Ceratina ornatifera* Cam. Type”. Cameron

(1897) described both sexes of *C. ornatifera*. According to van der Vecht (1952), the male specimen from Cameron's original materials turned out to be a different species. He suggested that the female type could be the female of *C. moderata*, and designated the female type as a lectotype of *C. ornatifera*. Baker (2002a) synonymized *C. ornatifera* with *C. moderata*. I have examined the lectotype and agree with Baker's conclusion. Unfortunately, I have not seen the original male of *C. ornatifera* to assess its species status.

The male holotype of *C. incognita* in the Natural History Museum, **LONDON**, is labeled "Simla 5 97" and "B.M. Type Hym. 17 b 216". The metasoma is lost in this specimen. Baker (2002) synonymized *C. incognita* into *C. moderata*. I have studied the type specimen and agree with Baker.

DISTRIBUTION.—*Ceratina moderata* is known from Northern India and Nepal (e.g., Himalchal Pradesh, Uttar Pradesh, Ulleri).

DIAGNOSIS AND COMPARATIVE COMMENTS.—*Ceratina moderata* can be distinguished from other *Ceratinidia* species by the presence of small to medium-sized punctures, usually with hairs, on the dorsolateral area of outer side of the antennal fossa and by its sparsely punctate mesepisternum. The large hypoepimeral area is impunctate. The subapical depression on the sixth sternum of male is broadly bilobed medially with a subequal lateral tooth (Figure 154). The structure of S6 of the male is found only in this species.

DESCRIPTION—**Female:** *Structure:* (1) Length 6.55–9.00 mm. Prosoma: (2) Clypeus with median longitudinal impressed area; dorsal and dorsolateral area of clypeus with slightly dense small to medium-sized punctures; median and lower parts smooth or slightly rugose with few scattered shallow punctures; median longitudinal carina vague. (3) Labrum with scattered medium-sized punctures and some bristles. (4) Paraocular area below antennal fossa smooth almost impunctate with few scattered small punctures. (5) Inner part of antennal fossa with slightly dense medium-sized punctures along frontal carina, outer part mostly with clumped of small punctures and hairs. (6) Dorsolateral part of antennal fossa area without smooth fovea, with clumps of small to medium-sized punctures and dense setae. (7) Supraclypeal area below frontal carina with 1–2 punctures. (8) Frons with scattered medium-sized punctures, vertex with more dense and coarse punctures. (9) Space between ocelli and upper part of compound eye with 1–2 coarse punctures. (10) Gena shiny, almost impunctate. (11) Preoccipital carina somewhat prominent; area behind ocelli nearly flat. (12) Hypostomal area impunctate; hypostomal carina not prominent.

Mesosoma: (13) Anterior third of scutum with sparse small to medium-sized punctures; posterior two thirds of scutum impunctate except posterior margin with dense punctures; one row of punctures along anteromedian line and another along parapsidal furrow. (14) Lateral margin of scutum lined with one or two rows of small fine punctures. (15) Procoxa with round angle on outer side at base. (16) Mesepisternum sparsely punctate laterally and ventrally; punctures more less sparse

posterolaterally near mesocoxal base; large impunctate area on hypoepimeral area. (17) Area around scrobe with large conspicuous impunctate area. (18) Propodeal triangle finely coriaceo-reticulate; lateral area of propodeum densely and finely punctate, without patch of dense hair anteriorly. Metasoma: (19)–(21) See Male. *Maculations* (yellow except as noted): Prosoma: (22) Marking on clypeus well-developed; upper lobe of inverted-T mark almost reaching frontoclypeal sulcus; lateral arms of marking thinner than upper lobe, sometimes reduced or absent. (23) Labrum black. (24) Mandible black. (25) Supraclypeal spot well-developed. (26) Frontal spot more or less oval, well-developed. (27) Marking on paraocular area reduced; present only on lower part and slightly hooked (Figure 28). (28) Genal marking small, slightly narrowed downward, extending $\frac{1}{4}$ of eye length. (29) Base of antennal scape black. Mesosoma: (30) Transverse mark on pronotum interrupted medially, not connected to yellow spot on pronotal lobe. (31) Spot behind pronotal lobe absent. (32) Scutum without longitudinal lines. (33) Axilla black. (34) Tegula reddish-brown translucent. (35) Scutellum with two small yellow spots. (36) Marking on metanotum absent. (37) Protrochanter with small marking on outer side apically; mesotrochanter usually with small marking on outer side apically. (38) Profemur often black (sometimes with small yellow spots on inner and outer sides). (39) Protibia and mesotibia with yellow marking on outer sides extending distally for $\frac{2}{3}$ of tibial lengths. (40) Metatibia with yellow spot at base. (41) Tarsi dark brown to black. (42) Metabasitarsus black. Metasoma: (43) Metasomal bands well

developed and unbroken; T1 with wide marking almost enclosing two black spots, no band on T5 and T6.

Male: As described for female except as follows: *Structure:* (1) Length 6.60–8.10 mm. Prosoma: (2) Clypeus smooth, almost impunctate with few small punctures along margin; median longitudinal impressed area and median carina absent. (3) Labrum smooth with few punctures. (5) Outer part of antennal fossa with coarse punctures, connected to dense punctures on dorsolateral area above the fossa. (8) Frons with few scattered punctures, vertex behind ocelli with dense and coarse punctures. (9) Space between ocelli and upper part of compound eye impunctate. Mesosoma: (16) Mesepisternum with scattered punctures laterally and ventrally; posterolateral area near mesocoxal base almost impunctate; large impunctate area on hypoepimeral area. (18) Propodeal triangle finely coriaceo-reticulate with prominent median carina; lateral area of propodeum densely and finely punctate, without patch of hair on anterior part. Metasoma: (19) Subapical depression on S6 broadly bilobed medially with submedian tooth; apical lobe not prominent (Figure 154). (20) T7 apically truncate; lateral angle of T7 rounded. (21) Distal part of gonocoxite slightly narrowed at apex, with bristles along apical margin; inner margin of gonocoxite slightly angulated. *Maculations* (yellow except as noted): Prosoma: (22) Marking on clypeus well-developed, occupying almost entire area except margin. (23) Labrum with marking enclosing three black spots. (25) Supraclypeal spot reduced, triangular. (26) Frontal spot absent. (27) Marking on paraocular area streak-like (Figure 127.)

(28) Genal marking absent or with small vague spot. Mesosoma: (30) Transverse marking on pronotum reduced to small lateral spot, not connected to yellow spot on pronotal lobe. (35) Scutellum marking with small vague spot. (37) Protrochanter and mesotrochanter usually black, sometimes with small vague spot at apices. (38) Profemur with yellow spots on inner and outer sides; outer side spot extending basad for 2/3 of femoral length. (39) Protibia and mesotibia black with yellow marking on outer sides extending distally from bases for entire lengths of tibiae. (40) Metatibia black with yellow marking at base, extending for entire length of tibia. (41) Tarsi dark brown to black. (42) Metabasitarsus yellow. Metasoma: (43) Metasomal bands more reduced than in female; T1 with wide marking almost enclosing two black spots, T2–T5 with bands slightly interrupted medially, no bands on T6 and T7.

SPECIMENS EXAMINED IN ADDITION TO TYPES.—26 (24♀, 2♂).

INDIA. Himalayas: 9 May 1964, F. L. Wain (1♀; **LAWRENCE-BAKER**). Himalchal Pradesh: Simla, September 1898, no collector's name (in Col. C. G. Nurse Collection, 1920–1972) (2♀, 1♂; **LAWRENCE-BAKER**). Utter Pradesh: Mussoorie Lal Tibba, 7,500 m., 17 October 1964, S. W. T. Batra (1♀; **LAWRENCE**), 15 June 1965, S. W. T. Batra (1♀; **LAWRENCE**), 21 June 1965, S. W. T. Batra (1♀; **LAWRENCE**), 25 June 1965, S. W. T. Batra (12♀; **LAWRENCE**), 1 July 1965, S. W. T. Batra (1♀; **LAWRENCE**), 7 July 1965, S. W. T. Batra (4♀; **LAWRENCE**); Mussoorie, 2,200 m, 23 April 1985, K. Ghorpade (1♀; **LAWRENCE**), 2,000 m, 8 May 1990, L. Packer (1♂; **LAWRENCE-BAKER**).

***Ceratina nigrolateralis* Cockerell**

FIGURE 30, 65, 99, 128, 155, 181 (see Figure section at the end of text)

Ceratina philippinensis nigrolateralis Cockerell, 1916: 305 [female]; *Ceratina nigrolateralis*, van der Vecht, 1952: 77–81 [recognized as a species; redescription of female and male; key to subspecies].

Ceratina acuticauda Cockerell, 1919a: 175 [male].

Ceratina incerta Cockerell, 1919b: 247 [female and male]; Cockerell, 1920c: 624 [mentioned in key]; Cockerell, 1929: 150 [new record from Thailand (Siam)].

Ceratina corbetti Cockerell, 1929: 151 [female, male].

TYPE MATERIAL.—The female holotype in the Natural History Museum, **LONDON**, is labeled “*Ceratina philippinensis nigrolateralis*”, “T.D.A. Cockerell B.M. 1934-527”, “3887”, “P. Princesa Palawan Baker”, “Type # 17 b 204”. The type is in good condition; it has one row of punctures along the parapsidal furrow and yellow marking on the base of the antennal scape.

The male holotype of *C. acuticauda* in the United States National Museum of Natural History, The Smithsonian’s Institution, **WASHINGTON, D.C.**, is labeled “Type No. 20705 U.S.N.M.”, “Buitenzorg [= Bogor] Java 4. 09”, and “Bryan & Palmer Coll”. The type is in good condition. *Ceratina acuticauda* is a male of *C. nigrolateralis* without yellow on the base of the scape.

The female holotype of *C. incerta* in the Natural History Museum, **LONDON**, is labeled “T.D.A. Cockerell B.M. 1934–527”, “Singapore Coll. Baker”, and “Type # 17 b 236”. The type is in good condition. *Ceratina incerta* is a darker form of *C. nigrolateralis* with meso and metatibiae black.

The female holotype of *C. corbetti* in the United States National Museum of Natural History, The Smithsonian’s Institution, **WASHINGTON, D.C.**, is labeled “Kuala Lumpur 7 ms 1928 Feb (Cockerell)” and “Type No. 58143 U.S.N.M.”. The type is in good condition. Van der Vecht (1952) synonymized *C. corbetti* under *C. nigrolateralis*, but retained *C. acuticauda* and *C. corbetti* as different subspecies. I have examined the type of *C. corbetti* and decided that it is a female of *C. acuticauda* [= *C. nigrolateralis*] with reduced yellow markings on the meso and metatibiae. I do not recognize any of these morphs as subspecies.

DISTRIBUTION.—*Ceratina nigrolateralis* is widely distributed throughout South East Asian countries (Laos, Thailand, Vietnam, Malaysia, Singapore, Indonesia, and Palawan Island, Philippines).

DIAGNOSIS AND COMPARATIVE COMMENTS.—*Ceratina nigrolateralis* can be distinguished from other *Ceratinidia* in the *compacta* subgroup by the absence of punctures along the parapsidal furrows (incomplete row of punctures in specimens from Palawan) and in the area between the furrow and the lateral margin of the scutum, and in the presence of a protuberance on the outer side of the procoxa.

Ceratina nigrolateralis is similar to *C. collusor* in many aspects, but can be

differentiated by the relatively large size and the absence of yellow marking on the base of scape (present in Philippine population).

Van der Vecht (1952) segregated four subspecies in *C. nigrolateralis*: *C. nigrolateralis nigrolateralis* (Palawan Island), *C. nigrolateralis acuticauda* (Indochina, Malay Peninsula, and Indonesia), *C. nigrolateralis incerta* (Singapore and Sumatra), and *C. nigrolateralis corbetti* (Indochina, Malay Peninsula, and Indonesia). However, I consider *C. nigrolateralis acuticauda* and *C. nigrolateralis corbetti* to be a single morph, and do not recognize the others as subspecies.

The description *C. nigrolateralis* below is based upon *C. nigrolateralis* morph *acuticauda*. Notable characters of morph *nigrolateralis* and *incerta* are mentioned in parentheses.

DESCRIPTION—**Female:** *Structure:* (1) Length 6.50–10.10 mm. Prosoma:(2) Clypeus smooth with shallow scattered punctures along entire margin; very few punctures on yellow area; few conspicuous setae on the lower part near labrum; longitudinal median carina vague (sometimes absent). (3) Labrum with dense coarse punctures, and with long bristles. (4) Paraocular area below antennal fossa with shallow scattered punctures. (5) Inner part of antennal fossa with coarse punctures along frontal carina, outer part impunctate or at most with few punctures. (6) Dorsolateral area above antennal fossa without smooth fovea. (7) Supraclypeal area below frontal carina impunctate. (8) Frons impunctate or with few strong punctures in lower part of antennal fossa area, but with dense and coarse punctures on upper part, and

throughout vertex. (9) Space between ocelli and upper part of compound eye with few scattered well-defined punctures. (10) Genal area with few shallow punctures. (11) Preoccipital carina not prominent; area behind ocelli slightly depressed. (12) Hypostomal area smooth. Mesosoma: (13) Anterior third of scutum with dense (punctures broader than interspaces) medium-sized punctures; posterior two thirds of scutum shiny with few or no punctures along parapsidal furrows and anteromedian line, but with dense punctures on posterior part before scuto-scutellar sulcus. (14) Lateral edge of scutum lined with single row of medium-sized punctures. (15) Procoxa with angularly produced on outer side at base. (16) Mesepisternum with dense medium to coarse punctures; scattered punctures (interspaces larger than punctures) ventrally and posterolaterally near mesocoxal base. (17) Area around scrobe with conspicuous impunctate area. (18) Propodeal triangle finely coriaceous-reticulate; lateral area of propodeum densely and finely punctate, sometimes with small patch of dense hair anteriorly. Metasoma: (19)–(21) See male. *Maculations* (yellow except as noted): Prosoma: (22) Inverted-T marking on clypeus, with small hook-like point downward on lateral arm, central arm well-developed, almost attaining frontoclypeal sulcus (some specimens with median incision in upper margin). (23) Labrum black. (24) Mandible black. (26, 27) Supraclypeal and frontal spots well-developed. (27) Marking on paraocular area widened from top to bottom in various ways (Figure 30). (28) Genal marking slightly narrowed downward, extending half to 4/5 of eye length. (29) Base of antennal scape often reddish brown to black (yellow in specimens from Palawan Island). Mesosoma:(30) Transverse

marking on pronotum more or less connected (sometimes connected by fine yellow line) to yellow spot on pronotal lobe. (31) Spot behind pronotal lobe absent or at most vague. (32) Scutum with four longitudinal lines. (33) Axilla black. (34) Tegula reddish-brown translucent. (35) Scutellum with large marking occupying entire area except anterior part; small incision in anterior margin of marking (some specimens from Singapore with triangular spot narrowed posteriorly). (36) Marking on metanotum absent. (37) Markings on apices of protochanter and mesotrochanter usually absent, at most vague. (38) Apex of profemur with yellow band extending basad on inner side for about half of femur length. (39) Markings on outer side of protibia and mesotibia (some specimens with markings reduced). (40) Metatibia with yellow at base and extending distad for $\frac{1}{4}$ of tibial length (sometime absent). (41) Tarsi reddish-brown to black. (42) Metabasitarsus reddish-brown. Metasoma: (43) Metasomal bands well developed and unbroken (some specimens have T3 band interrupted), except no band on T6; T1 with wide marking enclosing two small black spots.

Male: As described for female except as follows: *Structure*: (1) Length 5.50–9.80 mm. Prosoma: (2) Clypeus smooth, usually with vague longitudinal carina, and with small impression on each side; more punctures than female, most of them shallow; impressed area impunctate. (3) Labrum with sparse fine and medium-sized punctures; few setae present. (4) Punctures on paraocular area varied from slightly dense to scattered, and to a few shallow medium-sized punctures. (6) Dorsolateral

area of antennal fossa with strong smooth fovea; however, sometimes inconspicuous. (7) Supraclypeal area impunctate or at most with 1–2 punctures, and sometimes with ventral depression. (8) Frons and vertex with dense and coarse punctures throughout. (9) Space between ocelli and upper part of eye with well-defined punctures denser than in female, but less dense than on adjacent frons-vertex area. (10) Genal area with few scattered medium-sized punctures. Mesosoma: (13) Anterior third of scutum with dense medium-sized punctures, posterior two thirds of scutum more or less shiny with few punctures along parapsidal furrows; anterior part of anteromedian line with rows of punctures forming triangle extending for full length of the line; posterior part before scuto-scutellar sulcus with dense punctures (more coarse than in female). (14) Lateral edge of scutum with single row or two of medium-sized punctures. (15) Procoxa less angularly produced on outer side at base than in female. (17) Area around scrobe not as conspicuous as in female; punctures present around the area, but no hair. Metasoma: (19) S6 with small submedian tooth on each side of V-shape ridge on subapical depression (Figure 155); anterior part of S6 with coarse and dense punctures and long stiff bristles (no bristles near ridge); apical lobe not prominent. (20) T7 apically pointed with median keel and slightly rounded edges. (21) Distal part of gonocoxite of genitalia slightly narrowed, with two tufts of bristles on apical margin; inner margin of gonocoxite rounded. *Maculations* (yellow except as noted): Prosoma: (22) Inverted-T marking on clypeus well-developed, more extensive than in female. (23) Labrum with small marking. (24) Mandible usually black without marking, but sometimes with vague marking. (26) Frontal spot

reduced, linear. (27) Paraocular area marking very extensive, occupying almost entire area. (28) Genal marking extends longitudinally 4/5 of length of eye. (29) Base of antennal scape reddish-brown; some specimens with yellow spot on apex. Mesosoma: (30) Transverse marking on pronotum sometimes barely connected to yellow spot on pronotal lobe. (31) Yellow spot behind pronotal lobe absent. (38) Apex of profemur with yellow band on inner side, almost reaching base of femur. (39) Markings on outer side of protibia and mesotibia are more extensive than in female. (40) Metatibia with yellow marking at base and extending distad for ½ tibial length. (41) Tarsi ferruginous to dark brown. (42) Metabasis ferruginous to dark brown. Metasoma: (43) Metasomal bands less well developed than female; T3 band (sometimes T4 band) usually interrupted medially; T7 band absent.

SPECIMENS EXAMINED IN ADDITION TO TYPES.—125 (99♀, 26♂).

INDONESIA. Bali: Ubud, 28 May 1973, C.D. Michener (1♀; **LAWRENCE**). Central Java: Boyolali, 10 May 1973, 450 m., C.D. Michener (3♀, 3♂; **LAWRENCE**), 23 May 1973, 450 m., C.D. Michener (14♀, 5♂; **LAWRENCE**). Sumatra: Deli, No Collecting Date, D' Martin (1♀; **LAWRENCE**); Fort de Kock, 1926, 920 m., E. Jacobson (1♀; **BERLIN**); Siboga, October 1890 e March 1891, E. Modigliani (1♂; **SAN FRANCISCO**)

LAOS. Ban Kum: 20 November 1968, J. Rondon (5♀, 3♂; **HONOLULU**).

Khammouane: Phon Tiou, 10 June 1965, Sweeping, N. Wilson (2♀; **HONOLULU**).

Sedone: Pakse, 31 May 1967, Native Collector (1♀; **HONOLULU**). Vientiane: Ban Van Eue, 31 July 1965, Native Collector (1♂; **HONOLULU**); Dong Dok, 3 November 1965, Native Collector (1♀; **HONOLULU**); Tha Ngone, September 1965, Native Collector (1♀; **HONOLULU**). Wapikhamthong: Wapi, 15 March 1967, Native Collector (1♂; **HONOLULU**); 31 May 1967, Native Collector (1♀; **HONOLULU**)

MALAYSIA. Borneo: Sarawak, 6 September 1958, T.C. Maa (1♀; **HONOLULU**). Malay Peninsula: Ampang, E. of Kuala Lumpur, 3 June 1973, C.D. Michener (8♀; **LAWRENCE**), 4 August 1973, Phang Ong Wah (1♂; **LAWRENCE**), 30 September 1973, Phang Ong Wah (4♂; **LAWRENCE**); Bukit Lanjan, near Kuala Lumpur, 1 June 1973, C.D. Michener (1♀; **LAWRENCE**); Campus, U.M., 21 August 1979, T.K.L. (1♀; **LAWRENCE**); Ipoh, Perak, 10 August 1962, 70 m., E.S. Ross and D.Q. Cavagnaro (1♀; **SAN FRANCISCO**), near Kuala Lumpur, 4 August 1973, Phang Ong Wah, (2♀; **LAWRENCE**); Johor, Kota Tinggi Falls, 15–16 October 1986, John W. Wenzel (1♂; **LAWRENCE**); Pengarang, 11 November 1961, K.J. Kuncheria (1♀; **HONOLULU**), 15.3 km. W. of Sedili Besar, 16 October 1986, John W. Wenzel (3♀; **LAWRENCE**); Kuala Lumpur, 20 August 1973, Phang Ong Wah, 3 June 1973, C.D. Michener (1♀, 1♂; **LAWRENCE**), 5 August 1975, Rudolf Jander (1♀; **LAWRENCE**); Penang, George Town, 4 June 1973, C.D. Michener (3♀; **LAWRENCE**); Tasek Glugor, 21 August 1976, Aishah (1♀; **LAWRENCE**); Tasek Bera, Bahau, 17 October 1975, R. Jander (1♀; **LAWRENCE**); Ulr Gombak, 13 miles NE. of Kuala Lumpur, 2

June 1973, C.D. Michener (1♀; **LAWRENCE**); 16 miles NE of Kuala Lumpur, 12

August 1962, 1000, E.S. Ross and D.Q. Cavagnaro (1♀; **SAN FRANCISCO**)

PHILIPPINES. Palawan: Aborlan P.N.A.C., 21 April 1992, S.G. Reyes (1♀;

LAWRENCE), 23 April 1992, S.G. Reyes (6♀, 1♂; **LAWRENCE**); Bacuit, December,

1943, G. Boettcher (1♀; **BERLIN**); near Puerto Princesa, 15 April 1945, H.H.

Blackmore (2♀; **SAN FRANCISCO**)

SINGAPORE. Ulupandan: Lion L.H., 13 March 1999, No Collector's Name (1♂;

LAWRENCE); 15 August 1970, Harry Walker (1♀; **LOS ANGELES**); 17 October

1986, J.W. Wenzel (3♀, 1♂; **LAWRENCE**)

THAILAND. Bangkok: 17 April 1973, on flowers of *Zizyphas*, P.S. Messenger (1♀;

SAN FRANCISCO), 19 May 1973, on flowers, P.S. Messenger (8♀, 1♂; **SAN**

FRANCISCO), 6 June 1973, on flowers, P.S. Messenger (2♀; **SAN FRANCISCO**).

Chantaburi: ~2 km. S. of Chantaburi, 19–21 June 1969, 12 36'N 102 07'E, J.J.S.

Burton (1♀; **HONOLULU**). Chiang Mai: Amphur Mae Wang, Thanbon Donpao, Pa

Huay Kho, 20–30 April 1997, 18 41.54'N 98 48.417'E, 250 m., Malaise trap in field

at edge of deciduous forest, Saowapa Sonthichai (1♀; **LOS ANGELES**).

Kanchanaburi: 110 air km. W. of Bangkok, 25–27 April 1988, W.J. Pulawski (2♀;

SAN FRANCISCO). Nakhon Nayok: Nakhon Nayok, 21 January 1993, S. Boongird

and C.D. Michener (2♀, 1♂; **LAWRENCE**). Nakhon Ratchasima: Tha Chang, 10

February 1993, ex. *Callistemon*, S. Boongird and C.D. Michener (1♀; **LAWRENCE**).
Phuket: Phuket Island, 29 January 1993, S. Boongird and C.D. Michener (2♀;
LAWRENCE). Saraburi: August, Sakda (in Thai) (1♀; **BANGKOK**). Surat Thani:
Bang-O 25 km. SW. of Surat Thani, 30 January 1993, S. Boongird and C.D.
Michener (1♀; **LAWRENCE**). Trang: Khao Chong Nature Education Center, 21–24
July 1996, 07 35'N 99 46'E, Snelling and Sonthichai (3♀; **LOS ANGELES**)

VIETNAM. Dilinh (Djiring): Chute de Bobla, 7 km of Dilinh (Djiring), 840 m, 27
April 1960, R. E. Leech (1♀; **HONOLULU**). Fyan: 11 July–9 August 1961, 900–
1,000 m., N.R. Spencer (1♀; **HONOLULU**)

***Ceratina okinawana* Matsumura and Uchida**

FIGURE 31, 32, 66, 100, 129, 156, 182 (see Figure section at the end of text)

Ceratina okinawana Matsumura and Uchida, 1926:67 [erroneously described the type series sexes as females]; van der Vecht, 1952: 55–56 [indicated that the type series are males; redescription of female and male]; Hirashima, 1958: 75 [new record from Amami Island, Japan]; ? Wu, 1963: 84 [record from Southwestern China]; Hirashima, 1965: 258 [new record from Ryukyu Islands, Japan]; Yasumatsu and Hirashima, 1969: 68 [mentioned in key]; Wu, 1988: 97 [record from China]; Shiokawa, 1999: 260–262 [designated lectotype].

Ceratina simillima; Matsumura and Uchida, 1926: 67 [misidentification]

Ceratina okinawana sakishimensis Shiokawa, 1999: 262–263 [female and male]

TYPE MATERIAL.—*Ceratina okinawana* was described by S. Matsumura and T. Uchida (1926) based on three “females” from Okinawa Island. However, van der Vecht (1952) indicated that the original authors erroneously identified the male of *C. okinawana* as female, and identified the “true” female of *C. okinawana* (collected by the same authors at the same locality as the three “females” *C. okinawana*) as *C. simillima* Smith. The female and male were then redescribed in detail by van der Vecht (1952), but no lectotype was designated. Shiokawa (1999) examined one of the original three “female” *C. okinawana* deposited at Hokkaido University [the other two original specimens are lost according to Shiokawa (1999)], and confirmed that the specimen is a male *C. okinawana*, designated it as the lectotype, but did not examine the specimens identified by Matsumura and Uchida (1926) as *C. simillima* to verify whether or not they are females of *C. okinawana*.

I have examined the male lectotype of *C. okinawana* designated by Shiokawa (1999). The type is in good condition but the metasoma is detached from the body for dissecting the genitalic structure and terminal segments (S6 and T7). The lectotype of *C. okinawana* in Hokkaido University, Japan, **SAPPORO**, is a male labeled “Okinawa Island 1923 S. Sakaguchi” and “Lectotype *Ceratina okinawana* Matsumura & Uchida”. Shiokawa (1999) also named two subspecies of *C. okinawana*: *C. okinawana sakishimensis* from the Sakishima Islands and *C. okinawana taiwanensis* from Taiwan and Fukien (Southern China). I consider *C.*

okinawana taiwanensis as a separate species, *C. taiwanensis*. Therefore, only *C. okinawana okinawana* and *C. o. sakishimensis* are discussed here.

The male holotype of *C. okinawana sakishimensis* at Hokkaido University, Japan, **SAPPORO** (not seen), is labeled “Holotype: ♂, Inoda, Ishigaki Is., 2. V. 1970”. However, two paratypes (female and male), both in Hokkaido University, **SAPPORO**, were examined. The female paratype is labeled “Yonaguni Is. Higawa, 24–25 April 1988, Col. K. Goukon”. The male paratype is labeled “Nobaru Iriomote Is., 29 April 1970, M. Shiokawa”. Both paratypes are in excellent condition.

DISTRIBUTION.—*Ceratina okinawana okinawana* is recorded from the Ryukyu Islands including Okinawa, Iejima, and Amani Islands. The morph *sakishimensis* is recorded from Miyako and Yaeyama Islands, Japan.

DIAGNOSIS AND COMPARATIVE COMMENTS.—The pattern of punctation on the paraocular area of the female *C. okinawana* is similar to that of *C. lepida* and *C. bryanti*, with fine to coarse punctures clumped together on the median part, but only a few punctures present on lower and upper parts. The dorsal and dorsolateral areas of the clypeus have dense, small to medium-sized punctures; the median area is usually smooth and impunctate, but sometimes slightly rugose with a few punctures.

Ceratina okinawana can be distinguished from *C. lepida* by the dense punctation on the anterior part of the scutum (in both sexes), by the presence of yellow marking on the profemur (in female), and by the rounded apex of T7 (pointed apex in male *C.*

lepida). *Ceratina okinawana* differs from *C. bryanti* by the presence of yellow marking at the apex on the outer side of the profemur (in female) and by the presence of the incision on the median denticle between lateral teeth on the subapical depression of S6 and the rounded apex of T7 (in male).

In both sexes, the morph *sakishimensis* can be distinguished from *C. okinawana* morph *okinawana* by the conspicuous hypostomal carina, its lateral arm elevated apically. In the female of *sakishimensis* the metasomal bands are always well-developed and unbroken, whereas in *C. okinawana okinawana* the T2 and T3 bands are interrupted medially. I regard *C. o. sakishimensis* as a variation of *C. okinawana*, rather than as a subspecies.

DESCRIPTION—**Female:** *Structure:* (1) Length 7.70–10.80 mm. Prosoma: (2) Clypeus slightly rugose with small and medium-sized punctures mostly along dorsal and dorsolateral areas (in larger specimens, punctures dense), median area superficially smooth (sometimes rugose), with depression and vague median longitudinal carina. (3) Labrum with mixture of small and medium-sized punctures, and with many short bristles (in *C. o. sakishimensis*, labrum smooth, superficially rugose, with few small punctures). (4) Paraocular area below antennal fossa with dense medium-sized to coarse punctures clumped together on middle part, few punctures on lower part. (5) Inner part of antennal fossa with dense coarse punctures along frontal carina, outer part impunctate. (6) Dorsolateral area of antennal fossa area without smooth fovea. (7) Supraclypeal area below frontal carina impunctate

(sometimes slightly rugose with few small punctures). (8) Frons and vertex with dense and coarse punctures. (9) Space between ocelli and upper part of compound eye with scattered coarse punctures. (10) Gena shiny with few scattered punctures. (11) Preoccipital carina not prominent; area behind ocelli slightly depressed. (12) Hypostomal area impunctate; hypostomal carina strongly prominent (lateral arm of carina in morph *sakishimensis* is twice as long as in *C. okinawana* morph *okinawana*). Mesosoma: (13) Anterior third of scutum with dense, medium-sized punctures; posterior two thirds of scutum shiny and impunctate except posterior margin; at least one row of punctures along median line and parapsidal furrow. (14) Lateral margin of scutum lined with one or two rows of medium-sized punctures. (15) Procoxa with rounded angle on outer side at base. (16) Mesepisternum with dense coarse punctures laterally but punctures slightly less dense posterolaterally near mesocoxal base. (17) Area around scrobe with large conspicuous impunctate area. (18) Propodeal triangle finely coriaceous-reticulate; lateral area of propodeum densely and finely punctate, with small patch of dense hair anteriorly. Metasoma: (19)–(21) See male. *Maculations* (yellow except as noted): Prosoma: (22) Upper lobe of inverted-T marking triangular, reaching 2/3 or more of clypeal length; lateral arm of marking with small hook-like point downward (in morph *sakishimensis*, marking usually occupying almost entire area, except margins). (23) Labrum black. (24) Mandible black. (25) Supraclypeal spot well-developed. (26) Frontal spot well-developed. (27) Marking on paraocular area linear and curving inward along lower margin (hook-like) (Figure 31). (28) Genal marking slightly narrowed downward;

extending along half to 2/3 of eye length. In *C. okinawana sakishimensis*, genal marking extending along almost entire length of eye and hypostoma with small slanted spot near lateral arm of hypostomal carina [sometimes absent]). (29) Base of antennal scape dark brown. Mesosoma: (30) Transverse marking on pronotum, often interrupted medially, rarely connected to yellow spot on pronotal lobe. (31) Spot behind pronotal lobe absent or vague. (32) Scutum with four longitudinal lines (sometimes inner lines vague). (33) Axilla black. (34) Tegula reddish-brown, translucent. (35) Scutellum with a more or less rectangular marking, narrowed posteriorly; small incision on anterior margin of marking. (36) Marking on metanotum absent. (37) Protrochanter and mesotrochanter without markings apically. (38) Profemur dark brown with small yellow spot on outer side (sometimes inner spot also present in morph *sakishimensis*). (39) Protibia dark brown with basal yellow marking on outer side extending 2/3 of tibial length from base; mesotibia dark brown with small yellow spot at base (sometimes absent). (40) Metatibia with yellow spot at base. (41) Tarsi dark brown to black. (42) Metabasisarsus dark brown to black. Metasoma: (43) Metasomal bands well developed and unbroken, except on T2 and T3 sometimes interrupted medially.; no band on T6; T1 with wide marking not enclosing two black spots.

Male: As described for female except as follows: *Structure*: (1) Length 7.40–8.95 mm. Prosoma: (2) Clypeus smooth (sometimes slightly rugose, but not as in female) with few small punctures mostly along dorsal and dorsolateral areas, median area

smooth; median impressed area not as prominent as in female with vague median longitudinal carina. (3) Labrum smooth superficially rugose with few small punctures. In *C. o. sakishimensis*, labrum with mixture of small and medium-sized, and with many short bristles (4) Paraocular area below antennal fossa smooth except middle areas where clumps of small to medium-sized punctures exist, impunctate on lower part. In *C. okinawana sakishimensis*, paraocular area slightly rugose; median part with clumped of small to medium-sized punctures (denser and finer than in female). (7) Supraclypeal area below frontal carina impunctate. Mesosoma: (13) In *C. o. sakishimensis*, scutum punctation as in female *C. okinawana sensu stricto*; however, punctures denser on area between parapsidal furrow and lateral margin of scutum. Metasoma: (19) S6 with medium-sized submedian tooth and small median projection on subapical depression; median projection with median incision (Figure 156); anterior part of S6 with medium-sized and dense punctures and stiff long bristles (no bristles near tooth area); apical lobe prominent. (20) T7 apically round; lateral angle of T7 rounded. (21) Distal part of gonocoxite slightly broadened at apex (less broad in *C. okinawana sakishimensis*), with bristles along apical margin; inner margin of gonocoxite rounded. Maculations (yellow except as noted): Prosoma: (22) Inverted-T marking on clypeus well-developed, occupying almost entire area except dorsal margin. In *C. o. sakishimensis*, upper lobe of inverted-T marking triangular, reaching 2/3 or more of clypeal length; lateral arms of marking with small hook-like point downward. (23) Labrum black with median marking. (25) Supraclypeal spot more reduced than in female, triangular. (26) Frontal spot more reduced than in

female; more or less linear. (27) Marking on paraocular area linear above, abruptly widened and occupying entire lower part of area (Figure 129). (28) Genal marking streak-like; extending along at most half of eye length; hypostoma without spot near lateral arm of hypostomal carina. (29) Base of antennal scape dark brown; apex sometimes with small yellow marking. Mesosoma: (30) Transverse marking on pronotum usually broadly interrupted medially, not connected to yellow spot on pronotal lobe. (32) Scutum without longitudinal lines or with outer lines or with all four lines. (35) Scutellum with small triangular marking with small incision on anterior margin of marking or with two small spots. (38) Profemur dark brown often with small yellow spot on outer side, inner side sometimes with long yellow streak. In morph *sakishimensis*, profemur dark brown with small yellow spots on outer and inner sides; outer spot on apex, inner spot at base and extending distally for half to entire length of femur. (39) Protibia dark brown with yellow marking on outer side extending distally from base for almost entire tibial length; mesotibia dark brown with small yellow spot at base (sometimes absent). In morph *sakishimensis*, mesotibia dark brown with yellow spot at base and apex, spot at base extending for 2/3 of tibia length. (40) In morph *sakishimensis*, metatibia with yellow spot at base and apex (sometimes spot at apex absent), spot at base extending for half to almost entire length of tibia. (42) In morph *sakishimensis*, metabasitarsus dark brown to black with yellow marking on outer side. Metasoma: (43) Metasomal more bands reduced than in female; T2 and T3 bands broadly interrupted medially (sometimes

absent), T4 and T5 sometimes slightly interrupted medially, no bands on T1 (or vague), T6, and T7.

SPECIMENS EXAMINED IN ADDITION TO TYPES.—30 (20♀, 10♂).

JAPAN. Amami Island: Toen (Yamato), 5 August 1978, M. Shiokawa (2♂; **SAPPORO -SHIOKAWA**), 6 August 1978, M. Shiokawa (3♀; **SAPPORO -SHIOKAWA**). Ishigaki Island: Inoda, 9 August 1977, M. Shiokawa (1♀, 1♂; **SAPPORO -SHIOKAWA**), 10 August 1977, M. Shiokawa (1♀; **SAPPORO -SHIOKAWA**), 11 August 1977, M. Shiokawa (3♀, 2♂; **SAPPORO -SHIOKAWA**). Miyako Island: Fukuyama, 6 August 1977, M. Shiokawa (1♀, 1♂; **SAPPORO -SHIOKAWA**), 8 August 1977, M. Shiokawa (4♀, 1♂; **SAPPORO -SHIOKAWA**). Okinawa Island: Benoki, 4 May 1970, M. Shiokawa (3♀, 3♂; **SAPPORO -SHIOKAWA**); Izumi, 5 May 1970, M. Shiokawa (1♀; **SAPPORO -SHIOKAWA**), 5 August 1984, M. Shiokawa (3♀; **SAPPORO -SHIOKAWA**).

Ceratina papuana van der Vecht

FIGURE 33 and 67 (see Figure section at the end of text)

Ceratina papuana van der Vecht, 1952: 83–84 [Female and Male].

TYPE MATERIAL.— The female holotype of *C. papuana* is at the Nationaal Natuurhistorisch Museum, **LEIDEN** (not seen). The male paratype in the same

institution as the holotype is labeled, “N.W. New Guinea, Sorong K.P. Baroe, 8 July–14 August 1948, M. A. Lieftinck” and “Museum Leiden ex coll. M. A. Lieftinck”.

The paratype is in good condition, but with slight fungal infestation on prosoma and mesosoma.

DISTRIBUTION.—*Ceratina papuana* is only recorded from Sorong, Papua New Guinea.

DIAGNOSIS AND COMPARATIVE COMMENTS.—*Ceratina papuana* is included in the compacta subgroup because of the possession of a V-shape ridge on subapical depression of male S6. *Ceratina papuana* is similar to both *C. collusor* and *C. nigrolateralis*, in which the punctures along the parapsidal furrow and punctures on area between the furrow and the lateral margin of scutum are absent. But *C. papuana* can be distinguished from the latter two by the short upper lobe of the marking on the clypeus (upper lobe reaching almost half the clypeal length in female, and reaching almost 2/3 of the clypeal length with slight median incision in the male), by the absence of longitudinal lines on the scutum (sometimes only two outer lines present), and by the dense punctation on posterolateral area near mesocoxal base of mesopleuron.

I examined only one male paratype of *C. papuana*. Thus, I am not certain about the validity of this species since many characters are similar to *C. collusor* and

C. nigrolateralis beside the maculation pattern mentioned above. I treat *C. papuana* as a separate species at least until more specimens are available.

DESCRIPTION.— **Female:** as described in van der Vecht (1952): *Structure:* (1) Length 6.50–8.00 mm. Prosoma:(2) Clypeus with few scattered puncture; median carina vague. (4) Paraocular area below antennal fossa with few scattered puncture. (8) Frons and vertex densely punctate with coarse punctures. (10) Genal area almost impunctate. Mesosoma:(13) Anterior third of scutum with dense medium-sized punctures; posterior two thirds of scutum shiny with few or no punctures along parapsidal furrows and anteromedian line, but with dense punctures on posterior marginal area near scuto-scutellar sulcus. (16) Mesepisternum with dense medium to coarse punctures. (17) Small conspicuous area around scrobe impunctate. (18) Propodeal triangle finely coriaceo-reticulate; lateral area of propodeum densely and finely punctate. Metasoma: (19)–(20) See male. *Maculations* (yellow except as noted): Prosoma: (22) Upper lobe of inverted-T marking on clypeus reaching at most half of clypeal length, and with triangular apex. (26, 27) Supraclypeal spot slightly angulate above; frontal spot transverse. (27) Marking on paraocular area narrow, curved inward below. (29) Base of antennal scape black. Mesosoma:(30) Transverse marking on pronotum interrupted medially, not connected to yellow spot on pronotal lobe. (32) Scutum with vague outer longitudinal line or without lines. (35) Scutellum with rectangular marking, narrowed posteriorly; small incision in anterior margin of marking. (38) Apex of profemur with yellow band extending basad on inner side. (39) Markings present on outer sides of protibia and mesotibia, extending for half of

tibial lengths. (40) Metatibia with yellow marking extending distad for 2/3 of tibial length. (41) Tarsi pale ferruginous. (42) Metabasitarsus pale ferruginous.

Metasoma: (43) Metasomal bands well developed, T3 rarely slightly interrupted medially.

Male: Structure: (1) Length 6.50 mm. Prosoma:(2) Clypeus smooth with slightly impressed median area. (3) Labrum superficially smooth with scattered shallow punctures, and with few setae. (4) Paraocular area below antennal fossa with scattered shallow punctures, mostly near compound eye margin. (5) Inner part of antennal fossa with coarse punctures along frontal carina, outer part impunctate. (6) Dorsolateral area above antennal fossa with strong smooth fovea. (7) Supraclypeal area below frontal carina impunctate. (8) Frons and vertex densely punctate with coarse punctures. (9) Space between ocelli and upper part of compound eye with coarse punctures, but less dense than on the frons and vertex. (10) Genal area with scattered shallow punctures. (11) Preoccipital carina not prominent; area behind ocelli slightly depressed. (12) Hypostomal area smooth. Mesosoma:(13) Anterior third of scutum with dense medium-sized punctures; posterior two thirds of scutum shiny with one incomplete row of punctures along parapsidal furrow and a row of punctures along median line; but with dense punctures on posterior margin before scuto-scutellar sulcus. (14) Lateral edge of scutum lined with single row of medium-sized punctures. (15) Procoxa with rounded angle on outer side at base. (16) Mesepisternum with dense medium to coarse punctures. (17) Area around scrobe

with conspicuous impunctate area. (18) Propodeal triangle finely coriaceous-reticulate; lateral area of propodeum densely and finely punctate, with small patch of dense hair anteriorly. Metasoma: (19) S6 with V-shaped ridge with small tooth on each side of V-shape ridge on subapical depression; anterior part of S6 with coarse and dense punctures and stiff long bristles (no bristles near ridge); apical lobe not prominent. (20) T7 apically pointed with median keel and slightly round edges (according to van der Vecht (1952) description). (21) Genitalic structure unknown. *Maculations* (yellow except as noted): Prosoma: (22) Upper lobe of inverted-T marking on clypeus reaching almost 2/3 of clypeal length, and with slight median incision. (23) Labrum black. (24) Mandible black. (26, 27) Supraclypeal spot narrow; frontal spot absent. (27) Marking on paraocular area thin, widened from top to bottom (Figure 33). (28) Genal marking streak-like, extending half of eye length. (29) Base of antennal scape reddish brown. Mesosoma: (30) Transverse marking on pronotum interrupted medially, barely connected to yellow spot on pronotal lobe. (31) Spot behind pronotal lobe absent. (32) Scutum with vague outer line. (33) Axilla black. (34) Tegula reddish-brown translucent. (35) Scutellum with rectangular marking; small incision in anterior margin of marking. (36) Marking on metanotum absent. (37) Markings on apices of protrochanter and mesotrochanter vague. (38) Apex of profemur with yellow band extending basad on inner side for about 2/3 of femur length. (39) Markings present on outer sides of protibia and mesotibia, extending for entire tibial lengths. (40) Metatibia with yellow marking extending distad for entire of tibial length. (41) Tarsi reddish-brown to yellow. (42) Metabasitarsus yellow.

Metasoma: (43) Metasomal bands well developed, T2 and T3 slightly interrupted medially, no band on T7; T1 with wide marking not enclosing small black spots.

***Ceratina pulchripes* Shiokawa**

FIGURE 34, 68, 101, 130, 157, 183 (see Figure section at the end of text)

Ceratina pulchripes Shiokawa, 2002: 264–265 [male and female].

TYPE MATERIAL.—The male holotype of *C. pulchripes* at Hokkaido University, SAPPORO, Japan, is labeled “Kentin, Pingtung, TAIWAN, 1980.5.7, M. Shiokawa”. I did not examine the types, but specimens examined in this study were kindly provided by Mr. Makoto Shiokawa, the author of the species.

DISTRIBUTION.—*Ceratina pulchripes* is known only from Southern Taiwan.

DIAGNOSIS AND COMPARATIVE COMMENTS.—*Ceratina pulchripes* is a relatively small species and superficially resembles *C. accusator*. In both sexes of *C. pulchripes*, the upper lobe of the marking on the clypeus is poorly developed (though lateral area of marking is more developed in male than female), reaching at most half of the clypeal length. The female of *C. pulchripes* can be sometimes difficult to distinguish from *C. accusator*, but one can use maculation to help differentiate them. In *C. pulchripes*, T2 and T3 bands are unbroken (sometimes slightly interrupted

medially, but not as broadly as in *C. accusator*) and the spot behind the pronotal lobe is absent. S6 and T7 of males of both species are almost the same. However, the dorsoapical area of the gonocoxite lacks an inner apical carina (brimless as described by Shiokawa, 2002) in *C. pulchripes*, unlike *C. accusator*.

DESCRIPTION—**Female:** *Structure:* (1) Length 6.00–7.45 mm. Prosoma: (2) Clypeus smooth and shiny (sometimes slightly rugose) with small and medium-sized punctures mostly scattered along dorsal and dorsolateral areas, median area smooth (sometimes superficially rugose); median impressed area present with vague median longitudinal carina. (3) Labrum with slightly dense mixture of small and medium-sized punctures, and with some long bristles. (4) Paraocular area below antennal fossa smooth and shiny, almost impunctate except 4–7 medium-sized punctures on median area. (5) Inner part of antennal fossa with fairly dense medium-sized punctures along frontal carina, outer part impunctate. (6) Dorsolateral part of antennal fossa area without smooth fovea. (7) Supraclypeal area below frontal carina almost impunctate or at most with 1–2 punctures. (8) Frons with sparse coarse punctures, dorsolateral area adjacent to compound eye shiny and impunctate; vertex more densely punctate than frons. (9) Space between ocelli and upper part of compound eye with few scattered coarse punctures. (10) Gena shiny with few scattered punctured. (11) Preoccipital carina not prominent; area behind ocelli slightly depressed. (12) Hypostomal area with few scattered small shallow punctures; hypostomal carina not prominent. Mesosoma: (13) Anterior third of scutum with

dense medium-sized punctures; posterior two thirds of scutum shiny and impunctate except posterior margin; at least one row of punctures along median line. (14) Lateral margin of scutum lined with one or two rows of medium-sized punctures. (15) Procoxa with rounded angle on outer side at base. (16) Mesepisternum with dense coarse punctures laterally and ventrally; punctures slightly less dense posterolaterally near mesocoxal base. (17) Area around scrobe with conspicuous impunctate area. (18) Propodeal triangle finely coriaceous-reticulate; lateral area of propodeum densely and finely punctate, without patch of dense hair anteriorly. Metasoma: (19)–(21) See male. *Maculations* (yellow except as noted): Prosoma: (22) Upper lobe of inverted-T marking on clypeus reaching at most half of clypeal length, lateral arm with small hook-like projection pointed downward. (23) Labrum black. (24) Mandible black. (25) Supraclypeal spot well-developed. (21) Frontal spot oval, well-developed. (27) Marking on paraocular area narrow, linear and curving inward below (hook-like) (Figure 34). (28) Genal marking streak-like; extending half of eye length. (29) Base and apex of antennal scape dark brown. Mesosoma: (30) Transverse marking on pronotum connected to yellow spot on pronotal lobe. (31) Spot behind pronotal lobe absent. (32) Scutum with four longitudinal lines. (33) Axilla black. (34) Tegula reddish-brown translucent. (35) Scutellum with rectangular marking, slightly narrowed posteriorly, small incision on anterior margin of mark. (36) Marking on metanotum absent. (37) Protrochanter with vague marking at apex; mesotrochanter without marking. (38) Profemur dark brown with yellow spots on inner side, extending for almost entire length of femur. (39) Protibia and mesotibia ferruginous

with yellow markings on outer sides extending almost entire lengths of tibiae. (40) Metatibia with yellow spot at apex, extending $\frac{1}{4}$ of tibial length. (41) Tarsi ferruginous. (42) Metabasitarsus ferruginous. Metasoma: (43) Metasomal bands well developed and unbroken, except as indicated below; T1 with marking vague or almost enclosing two black spots, T2 and T3 bands sometimes slightly interrupted medially, no band on T6.

Male: As described for female except as follows: *Structure*: (1) Length 6.95–7.30 mm. Prosoma: (2) Clypeus smooth and shiny (sometimes slightly rugose) with few scattered small punctures in dorsal and dorsolateral areas, median area smooth; median impressed area and median longitudinal carina not as prominent as in female. (3) Labrum smooth with few small shallow punctures. (4) Paraocular area below antennal fossa smooth with few scattered medium-sized punctures. (5) Inner part of antennal fossa with one or two rows of medium-sized punctures along frontal carina, outer part impunctate. Metasoma: (19) S6 with submedian tooth and median tooth on subapical depression (Figure 157); anterior part of S6 with coarse punctures and bristles (no bristles near tooth area; bristles not dense); apical lobe not prominent. (20) T7 apically rounded, slightly produced in middle and lateral area. (21) Distal part of gonocoxite slightly broad but brimless, with bristles along apical margin; inner margin of gonocoxite slightly angulated. *Maculations* (yellow except as noted): Prosoma: (22) Upper lobe of inverted-T marking on clypeus reaching at most half of clypeal length, lower part of clypeus entirely occupied by marking. (23) Labrum

yellow. (25) Supraclypeal spot more reduced than in female, triangular (26) Frontal spot reduced to small spot or absent (27) Marking on paraocular area gradually widened from top to bottom (Figure 130). Mesosoma: (30) Transverse marking on pronotum interrupted medially, not connected to yellow spot on pronotal lobe. (32) Scutum with two inner longitudinal lines, outer lines weak. (35) Scutellum with small triangular marking, small incision on anterior of marking. (38) Profemur dark brown with yellow spot on inner side extending for entire length of femur. (39) Protibia and mesotibia ferruginous with yellow markings on outer sides extending entire lengths of tibiae. (40) Metatibia with yellow spot at apex, extending basad for 1/2 of tibial length. (41) Tarsi ferruginous. (42) Metabasis dark brown. Metasoma: (43) Metasomal bands more reduced than in female; T1 with vague marking, T2 and T3 bands interrupted medially, T4–T6 bands usually unbroken, no band on T7.

SPECIMENS EXAMINED IN ADDITION TO TYPES.—5 (3♀, 2♂).

TAIWAN. Kentin Prefecture: 2 May 1974, M. Shiokawa (1♀, 1♂; **SAPPORO - SHIOKAWA**), 7 May 1980, M. Shiokawa (1♂; **SAPPORO -SHIOKAWA**), 8 May 1980, M. Shiokawa (2♀; **SAPPORO-SHIOKAWA**).

Ceratina punctigena van der Vecht

FIGURE 35, 69, 102, 131 (see Figure section at the end of text)

Ceratina punctigena van der Vecht, 1952: 73 [male and female]

TYPE MATERIAL.—The male holotype at the Nationaal Natuurhistorisch Museum, **LEIDEN**, is labeled “W. Java, Koeripan, 19 August 1934, Dr. J. v. d. Vecht” and “*Ceratina punctigena* n. sp., det. J. v. d. Vecht 52”. The type is in good condition.

DISTRIBUTION.—*Ceratina punctigena* is only recorded from Java, Indonesia. This interpretation stems from only two specimens examined in this study, and from four specimens listed by van der Vecht (1952).

DIAGNOSIS AND COMPARATIVE COMMENTS.—Female of *C. punctigena* is similar to *C. cognata* in the yellow maculation and punctation, except that the prosoma and mesosoma are more densely and coarsely punctate in the latter. The clypeus and paraocular areas in *C. punctigena* have dense, small to medium-sized punctures; the frons and vertex are also heavily punctate; the gena has dense coarse punctures, hence the name *punctigena*; the scutum is more punctate than in *C. cognata* (see description), and the punctures of the mesepisternum are more coarse and dense.

Van der Vecht (1952) noted that male of *C. punctigena* has similar apical genitalia and metasomal characters to *C. cognata*. I did not dissect and examine the terminal segments and genitalic structure of *C. punctigena*. However, one can easily differentiate the male of *C. punctigena* from *C. cognata* by the characters listed for females.

DESCRIPTION—**Female:** *Structure:* Prosoma: (2) Clypeus with dense small-sized punctures; longitudinal median carina vague. (3) Labrum with coarse punctures and short scattered setae. (4) Paraocular area below antennal fossa with dense small and medium-sized punctures. (5) Inner part of antennal fossa with coarse punctures along frontal carina, outer part impunctate with scattered medium-sized punctures. (6) Dorsolateral margin of antennal fossa without smooth fovea. (7) Supraclypeal area below frontal carina with 1–2 punctures and ventral depression. (8) Frons and vertex with dense coarse punctures. (9) Space between ocelli and upper part of compound eye with some coarse punctures. (10) Genal area with dense coarse punctures. (11) Preoccipital carina not prominent; area behind ocelli slightly depressed. (12) Hypostomal area with scattered coarse punctures. Mesosoma: (13) Anterior portion of scutum with dense medium-sized to coarse punctures occupying almost half of scutum; small area between anteromedian line and parapsidal furrows and small area around parapsidal furrows impunctate; two or more rows of punctures along anteromedian line; dense punctures on posterior part of scutum before scuto-scutellar sulcus. (14) Lateral margin of scutum lined with two or more rows of medium-sized or coarse punctures. (15) Procoxa with rounded angle on outer side at base. (16) Mesepisternum with dense coarse punctures; punctures less dense on posterolateral area near mesocoxal base. (17) Area around scrobe with conspicuous impunctate area. (18) Propodeal triangle finely coriaceo-reticulate; lateral area of propodeum densely and finely punctate, with small patch of dense hair anteriorly. Metasoma: (19)–(21) See male. *Maculations* (yellow except as noted): Prosoma: (22) Inverted-T

marking on clypeus well-developed, with small hook-like point downward on lateral arm. (23) Labrum black without yellow spot (sometimes with vague spot). (24) Mandible black. (25) Supraclypeal spot well-developed. (26) Frontal spot well-developed. (27) Marking on paraocular area gradually widened from top to bottom (Figure 35). (28) Genal marking slightly narrowed downward, extending half to 2/3 of eye length. (29) Base of antennal scape yellow. Mesosoma: (30) Transverse marking on pronotum well connected to yellow spot on pronotal lobe. (31) Spot behind pronotal lobe absent. (32) Scutum without yellow longitudinal lines. (33) Axilla black. (34) Tegula reddish-brown translucent. (35) Scutellum with large marking occupying entire area except anterior part; small incision on anterior margin of marking. (36) Marking on metanotum vague. (37) Markings on apices of protrochanter and mesotrochanter usually absent or at most vague. (38) Apex of profemur with yellow band extending basad on inner side occupying 2/3 of femoral length. (39) Markings present on outer side of protibia and mesotibia, extending almost entire length of tibia. (40) Metatibia with yellow marking at base, extending distad for 2/3 of tibial length. (41) Tarsi reddish brown. (42) Metabasitarsus with marking at base. Metasoma: (43) Metasomal bands narrowed medially (T2, T3, and T4 bands interrupted medially), T5 band well-developed; no band on T6; T1 with marking not enclosing black spots.

Male: As described for female except as follows: *Structure*: (1) Length 6.95 mm.

Prosoma: (2) Clypeus with dense small punctures, fewer punctures on median area;

longitudinal median carina vague. (4) Paraocular area below antennal fossa with dense, shallow, coarse punctures. (9) Space between ocelli and upper part of compound eye with dense coarse punctures. Metasoma: (19)–(21) Terminal segments (S6 and T7) and genitalic structure were not dissected (see Diagnosis). *Maculations* (yellow except as noted): Prosoma: (22) Marking on clypeus well-developed, occupying almost entire area except margins. (23) Labrum black without yellow spot. (26) Frontal spot absent. (27) Marking on paraocular area abruptly widened from top to bottom, occupying almost entire area (Figure 131). (28) Genal marking streak-like, extending half of eye length. Mesosoma: (30) Transverse marking on pronotum interrupted medially, but well connected to yellow spot on pronotal lobe. (35) Scutellum with marking triangular; small incision on anterior margin of marking. (36) Marking on metanotum absent. (37) Markings on apices of protrochanter and mesotrochanter. (40) Metatibia with yellow marking at base and extending distad for entire tibia length. (41) Tarsi reddish brown to yellow. (42) Metabasisarsus yellow. Metasoma: (43) Metasomal bands reduced (T2, T3, and T4 bands interrupted medially), T5 band with small median interruption; no band on T7; T1 with marking not enclosing black spots.

SPECIMENS EXAMINED IN ADDITION TO TYPES.—1 ♀

INDONESIA. Central Java: 6 km NE of Prambanan, 24 May 1973, C.D. Michener (1 ♀; **LAWRENCE**).

***Ceratina rugifrons* Smith**

FIGURE 36, 70, 103, 132, 158, 184 (see Figure section at the end of text)

Ceratina rugifrons Smith, 1879: 93 [Male]; van der Vecht, 1952: 64–65 [description of female and redescription of male]; Baker, 2002b: 338–339, fig. 1, 2, and 12 [redescription of female and male].

TYPE MATERIAL.—The type of *C. rugifrons* in the Natural History Museum, **LONDON**, is a male labeled “Type # 17 b 217”, “57 101”, and “Celebes”. The type is in good condition. I designate as lectotype this type of *C. rugifrons* in **LONDON**, and add a red label “*Ceratina rugifrons* Smith, Lectotype, N. Warrit, 2007”.

DISTRIBUTION.—*Ceratina rugifrons* is known from Sulawesi (formerly known as Celebes), Indonesia, and Negros Island, Philippines.

DIAGNOSIS AND COMPARATIVE COMMENTS.—*Ceratina rugifrons* is similar to the sympatric species, *C. carinifrons*, but can be distinguished from the latter by the denser punctures (interspaces 1–1.5 times broader than puncture diameter) on the clypeus and paraocular area, by the dense punctures on the antennal fossa, by the dense punctures on the frons and vertex, and by the presence of a row of punctures along the parapsidal furrow and along the anteromedian line of the scutum.

In male *C. rugifrons*, the medium-sized lateral teeth on the subapical depression of S6 are separated by at least 5 times the length of the lateral teeth, and the apical lobe is prominent.

DESCRIPTION.— **Female:** *Structure:* (1) Length 8.05–9.50 mm. Prosoma: (2) Clypeus densely and coarsely punctate throughout. (3) Labrum with dense medium-sized and coarse punctures, and with some long bristles. (4) Paraocular area below antennal fossa densely and coarsely punctate. (5) Inner part of antennal fossa with dense coarse punctures along frontal carina, outer part also with dense coarse punctures. (6) Dorsolateral area of antennal fossa area densely and coarsely punctate throughout, with small smooth fovea; conspicuous shiny convex impunctate area between dorsolateral area of antennal fossa and compound eye. (7) Supraclypeal area below frontal carina fairly densely punctate. (8) Frons and vertex densely and coarsely punctate. (9) Space between ocelli and upper part of compound eye densely and coarsely punctate. (10) Genal area shiny with scattered shallow punctures. (11) Preoccipital carina not prominent; area behind ocelli slightly depressed. (12) Hypostomal area with scattered shallow punctures. Mesosoma: (13) Anterior portion of scutum densely and coarsely punctate; punctate area tapering along median line and parapsidal furrow; posterior margin of scutum densely and coarsely punctate; large impunctate area between median line and parapsidal furrow; scattered punctures along these lines. (14) Lateral margin of scutum lined with two or more rows of coarse punctures. (15) Procoxa pointed on inner side, but round on outer side at base.

(16) Mesepisternum with dense uniformly coarse punctures laterally and slightly less dense posterolaterally near mesocoxal base, ventral side with dense fine punctures.

(17) Area around scrobe with conspicuous convex impunctate area. (18) Propodeal triangle reticulate, often with median carina; lateral area of propodeum densely punctate with medium-sized punctures, with small patch of dense hair anteriorly.

Metasoma: (19)–(21) See male. *Maculations* (yellow except as noted): Prosoma: (22) Upper lobe of inverted-T marking absent or usually reaching at most half of clypeal length (sometimes with small incision on upper margin); lateral arm with small hook-like point downward (difficult to see in large specimens). (23) Labrum black with small vague spot. (24) Mandible black. (25) Supraclypeal spot well-developed. (26) Frontal spot near frontal carina small and oval. (27) Marking on paraocular area linear, curved inward on lower part (hook-like); marking extending up no more than level of antennal socket (Figure 36). (28) Lateral genal marking thick, slightly narrowed downward; extending half of eye length. (29) Base and apex of antennal scape ferruginous (sometimes yellow). Mesosoma: (30) Transverse marking on pronotum, often interrupted medially, rarely connected to yellow spot on pronotal lobe. (31) Spot behind pronotal lobe present, size varied. (32) Scutum with outer longitudinal lines only. (33) Axilla black. (34) Tegula dark reddish-brown translucent. (35) Scutellum with marking more or less triangular; anterior margin with small incision. (36) Marking on metanotum absent. (37) Protochanter and mesotrochanter with yellow markings apically. (38) Profemur dark brown with yellow spots at apex, extending basad on inner side for half of femoral length; lower

part of procoxa with brown transverse marking. (39) Protibia and mesotibia ferruginous with yellow markings on outer sides extending almost entire tibial lengths. (40) Metatibia dark ferruginous with small yellow spot at base. (41) Tarsi ferruginous. (42) Metabasitarsus dark ferruginous. Metasoma: (43) Metasomal bands reduced; T1 band not enclosing small spot, T2, T3, and T4 bands interrupted medially (T2 and T3 broadly interrupted), T5 band unbroken, no band on T6.

Male: As described for female except as follows: *Structure*: In some specimens punctures significantly larger than in females: (1) Length 6.10–8.15 mm. Prosoma: (3) Labrum with dense medium-sized and coarse punctures, and with few setae. (6) Dorsolateral area of antennal fossa area densely and coarsely punctate throughout, with smooth fovea; area between dorsolateral area of antennal fossa and compound eye usually conspicuously shiny, convex, and impunctate, in some specimens with large punctures dense and coarse. (7) Supraclypeal area below frontal carina densely and coarsely punctate. (10) Genal area densely and coarsely punctate on upper part; lower part with punctures more remote and scattered. (12) Hypostomal area with scattered medium-sized punctures. Mesosoma: (13) Scutum densely and coarsely punctate with larger punctures than in female; small area between median line impunctate. (15) Procoxa with rounded angle on outer side at base. Metasoma: (19) S6 with medium-sized submedian tooth on subapical depression distant from each other (5 times length of submedian tooth) (Figure 158); anterior part of S6 with coarse and dense punctures and stiff bristles (no bristles near tooth); apical lobe

prominent. (20) T7 apically slightly pointed with rounded lateral angle. (21) Distal part of gonocoxite of genitalia somewhat broad, with bristles along apical margin; inner margin of gonocoxite slightly angulated. *Maculations* (yellow except as noted): Prosoma: (22) Upper lobe of inverted-T marking (sometimes absent), reaching at most half of clypeal length (sometimes with small incision on upper margin); lateral arm with small hook-like point downward (difficult to see in large specimens); margin more or less distorted due to dense punctation. (23) Labrum black with yellow spot. (25) Supraclypeal spot linear, margin distorted due to dense punctation. (26) Frontal spot absent. (27) Marking on paraocular area triangular, margin distorted due to dense punctation; marking extending not above level of antennal socket (Figure 132). (28) Genal marking linear, extending no more than 1/3 of eye length. (29) Base and apex of antennal scape ferruginous. Mesosoma: (30) Transverse marking on pronotum often interrupted medially, connected to yellow spot on pronotal lobe. (31) Spot behind pronotal lobe present, size varied (sometimes absent). (32) Scutum without yellow longitudinal lines (sometimes with small weak outer line). (38) Profemur dark brown with yellow spot at base, extending basad on inner side for almost entire length of tibia; lower part of profemur black. (39) Protibia and mesotibia yellow with inner side dark brown. (40) Metatibia often ferruginous with yellow spot on inner side at apex (in specimens with large punctures, metatibia yellow). (41) Tarsi ferruginous to yellow. (42) Metabasitarsus ferruginous to yellow. Metasoma: (43) Metasomal bands reduced slightly more than in female; T1 band reduced or vague, T2–T4 bands broadly interrupted medially, T5 and T6

bands sometimes slightly interrupted medially, no band on T7. Metasomal bands in males with larger punctures more developed than in female; T1 band not enclosing small spot (sometimes vaguely), T2 and T3 bands broadly interrupted medially, T4–T6 bands unbroken, no band on T7.

SPECIMENS EXAMINED IN ADDITION TO TYPES.—31 (14♀, 17♂).

INDONESIA. Sulawesi: Central Sulawesi, Napu Valley ca. 100 km. SE of Palu, Wuasa, 1,100 m., 14 December 2000, A. M. Klein (1♀, 1♂; **LAWRENCE-BAKER**), 8 January 2001, A. M. Klein (1♀, 1♂; **LAWRENCE-BAKER**); NE Sulawesi, 47 km wsw Kotamobagu, Dumoga-Bone National Park, Toraut (forest edge), 211 m., April 1985, G. R. Else (3♀, 3♂; **LAWRENCE-BAKER**), May 1985, G. R. Else (4♀, 10♂; **LAWRENCE-BAKER**), June 1985, G. R. Else (4♀, 2♂; **LAWRENCE-BAKER**).

PHILIPPINES. Negros: Camp Lookout, Valencia, 15 January 1961, H. Torrevillas (1♀; **HONOLULU**).

Ceratina rugosoclypeata Warrit, new species

FIGURE 37, 71, 104, 133, 159, 185 (see Figure section at the end of text)

TYPE MATERIAL.—The female holotype is deposited in the University of Kansas Natural History Museum, **LAWRENCE**. It is in excellent condition and is labeled

“SOUTH INDIA: Nilgiri Hills, Naduvattam. 6000 ft., 12 May 1950, P. Susai Nathan”. Sixteen paratypes are designated as follows:

Five female paratypes with the same data as the holotype and one male paratype labeled “SOUTH INDIA: Nilgiri Hills, Devala, 980 m., October 1960, Nathan” are in the University of Kansas Natural History Museum, **LAWRENCE**. Three female paratypes labeled “SOUTH INDIA: Nilgiri Hills, Naduvattam. 6000 ft., 11 May 1950, P. Susai Nathan” and one male paratype labeled “SOUTH INDIA: Nilgiri Hills, Devala, 980 m., October 1960, Nathan” are in The Natural History Museum, **LONDON**. Three female paratypes labeled “SOUTH INDIA: Nilgiri Hills, Naduvattam. 6000 ft., 11 May 1950, P. Susai Nathan” and one male paratype labeled “SOUTH INDIA: Nilgiri Hills, Cherangode, 3,500 ft, November 1950, P. Susai Nathan” are deposited in the United States National Museum of Natural History, The Smithsonian’s Institution, **WASHINGTON, D.C.** Two female paratypes labeled “SOUTH INDIA: Nilgiri Hills, Naduvattam. 6000 ft., 11 May 1950, P. Susai Nathan” are in the American Museum of Natural History, **NEW YORK**.

ETYMOLOGY—The name *rugosoclypeata* is a compound word from Latin for rugose and clypeus meaning “wrinkled clypeus”, for its distinctive feature.

DISTRIBUTION.—*Ceratina rugosoclypeata* is known only from the Nilgiri Hills in South India.

DIAGNOSIS AND COMPARATIVE COMMENTS.—*Ceratina rugosoclypeata* is similar to *C. accusator* in size and maculation. The upper lobe of the female clypeal marking of both species rarely reaches more than half of clypeal length. The female *C. rugosoclypeata* can be distinguished from *C. accusator* by the rugose clypeus, by more punctures and setae on dorsolateral area above the antennal fossa on the frons, and by the less dense punctation (interspaces larger than puncture diameter) on the posterolateral side of the mesepisternum near mesocoxal base. S6 of the male *C. rugosoclypeata* has submedian tooth on subapical depression, but lacks a median tooth, unlike *C. accusator*. T7 of the male *C. rugosoclypeata* is rounded, but with a small midapical point.

DESCRIPTION—**Female:** *Structure:* (1) Length 6.05–6.85 mm. Prosoma: (2) Clypeus conspicuously rugose with strong, ill-defined punctures along dorsal and dorsolateral margin; median area of clypeus rugose, with impressed area. (3) Labrum with scattered medium-sized punctures and some long bristles. (4) Paraocular area below antennal fossa often smooth (or superficially rugose) with scattered fine small punctures (sometimes with dense coarse punctures). (5) Inner part of antennal fossa with dense coarse punctures along frontal carina, outer part impunctate. (6) Dorsolateral part of antennal fossa area without small smooth fovea. (7) Supraclypeal area below frontal carina with at most 1–2 punctures. (8) Frons often with dense coarse punctures (sometimes only moderately dense); vertex behind ocelli with denser coarse punctures. (9) Space between ocelli and upper part of compound eye

with scattered coarse punctures. (10) Gena shiny with few scattered punctures. (11) Preoccipital carina not prominent; area behind ocelli slightly depressed. (12) Hypostomal area with few shallow punctures; hypostomal carina slightly prominent.

Mesosoma: (13) Anterior fourth of scutum with sparse small to medium-sized punctures, interspaces larger than punctures diameters; posterior three fourths of scutum shiny and almost impunctate except posterior part; few punctures along anteromedian line. (14) Lateral margin of scutum lined with one row of medium-sized punctures. (15) Procoxa with round angle on outer side at base. (16) Mesepisternum with dense medium-sized punctures laterally and ventrally except punctures less dense posterolaterally near mesocoxal base. (17) Area around scrobe with large conspicuous impunctate area. (18) Propodeal triangle finely coriaceous-reticulate; lateral area of propodeum densely and finely punctate, without patch of dense hair anteriorly. Metasoma: (19)–(21) See male. *Maculations* (yellow except as noted): Prosoma: (22) Upper lobe of inverted-T marking on clypeus reaching at most half of clypeal length. (23) Labrum dark brown. (24) Mandible dark brown. (25) Supraclypeal spot narrow but well-developed. (26) Frontal spot well-developed (sometimes reduced to small line). (27) Marking on paraocular area linear; lower part slightly bend inward (hook-like) (Figure 37.) (28) Genal marking slightly narrowed downward, extending half of eye length. (29) Base of antennal scape dark brown.

Mesosoma: (30) Transverse marking on pronotum unbroken, often not connected to yellow spot on pronotal lobe. (31) Spot behind pronotal lobe absent. (32) Scutum often with four longitudinal lines. (33) Axilla black. (34) Tegula reddish-brown

translucent. (35) Scutellum with more or less rectangular marking (sometimes triangular), narrowed posteriorly; anterior margin of marking with slight median incision. (36) Marking on metanotum absent. (37) Protrochanter and mesotrochanter usually with faint yellow marking apically. (38) Profemur dark brown with yellow spot on outer side of apex. (39) Protibia dark brown with yellow mark at base, extending distally for almost entire tibial length; mesotibia dark brown with yellow spot at base. (40) Metatibia dark brown with yellow spot at base. (41) Tarsi dark brown. (42) Metabasitarsus dark brown. Metasoma: (43) Metasomal bands well-developed and unbroken; T1 band not enclosing black spots, no band on T6.

Male: As described for female except as follows: *Structure*: (1) Length 5.60–5.75 mm. Prosoma: (2) Clypeus smooth, almost impunctate, with few small punctures in dorsolateral area; median impressed area not as prominent as in female (darker form with distinct median carina). (3) Labrum slightly rugose with few small punctures. (4) Paraocular area below antennal fossa often smooth with few fine small punctures along compound eye. (5) Inner part of antennal fossa with slightly dense, medium-sized punctures along frontal carina, outer part impunctate (darker form with distinct coarse punctures along frontal carina). (6) Dorsolateral part of antennal fossa area with small smooth fovea. (7) Supraclypeal area below frontal carina impunctate. (8) Frons with scattered coarse punctures (far less dense than in female); vertex behind ocelli with denser coarse punctures. (9) Space between ocelli and upper part of compound eye with few coarse punctures. (10) Gena shiny, almost impunctate. (12)

Hypostomal area with few shallow punctures; hypostomal carina not prominent.

Mesosoma: (17) Area around scrobe with conspicuous impunctate area, smaller than in female. Metasoma: (19) S6 with submedian tooth on subapical depression (Figure 159); anterior part of S6 with coarse punctures and bristles (no bristles near tooth; bristles not dense); apical lobe not prominent. (20) T7 apically pointed, with round angle laterally. (21) Distal part of gonocoxite slightly broad, with bristles along apical margin; inner margin of gonocoxite slightly angulate. *Maculations* (yellow except as noted): Prosoma: (22) Inverted-T marking on clypeus with upper lobe reaching at most 2/3 of clypeus (darker form without upper lobe). (23) Labrum yellow enclosing three black spots (darker form darker brown). (24) Mandible dark brown. (25) Supraclypeal spot reduced, triangular or reduced to small spot. (26) Frontal spot reduced to small spot or absent. (27) Marking on paraocular area linear, gradually widened from top to bottom (Figure 133). (28) Genal marking slightly narrowed downward; extending 1/4 to half of eye length. (29) Base of antennal scape dark brown. Mesosoma: (30) Transverse marking on pronotum, interrupted medially (sometimes absent), often connected to yellow spot on pronotal lobe. (31) Spot behind pronotal lobe absent. (32) Scutum without longitudinal lines or with two inner longitudinal lines. (33) Axilla black. (34) Tegula reddish-brown translucent. (35) Scutellum with triangular marking (darker form without marking); anterior margin of marking with slight median incision. (36) Marking on metanotum absent. (38) Profemur dark brown with yellow spots on outer side and inner side of apex; sometimes spot on inner side extending for 2/3 of femoral length. (39) Protibia dark

brown with yellow marking at base, extending distally for almost entire tibial length; mesotibia dark brown with yellow spot at base, extending for 2/3 of tibia length. (40) Metatibia dark brown with yellow spot at base, extending for 2/3 of tibial length. (41) Tarsi ferruginous. (42) Metabasitarsus ferruginous. Metasoma: (43) Metasomal bands more reduced than in female; T1 band often absent, T2 and T3 bands broadly interrupted medially (sometimes T2 band absent), T4 band often interrupted medially, T5 band unbroken, T6 with vague yellow marking, T7 without band.

Ceratina simillima Smith

FIGURE 38, 72, 105, 134, 160, 186 (see Figure section at the end of text)

Ceratina simillima Smith, 1854: 225 [male]; van der Vecht, 1952: 61–62

[redescription]; Wu, 2000: 172–173 [record from China].

Ceratina eburneopicta Cockerell, 1911: 185 [female].

TYPE MATERIAL.—The male type of *C. simillima* in the Natural History, **LONDON**, is labeled “E. Ind [= Eastern India]”, “52 109”, and “B.M. Type Hym. 17 b 212”. I designate it as lectotype and add a red label “*Ceratina simillima* Smith, Lectotype, N. Warrit, 2007”.

Ceratina eburneopicta was synonymized with *C. simillima* by van der Vecht (1952). I have examined the female holotype of *C. eburneopicta* and agree with van der Vecht’s treatment. The female holotype of *C. eburneopicta* in **LONDON** is

labeled “*Ceratina eburneopicta* Ckll.”, “Salsette”, “Bombay Presidency. Pres. By E. Comber 1910-255” and “B.M. Type Hym. 17 b 215”.

DISTRIBUTION.—*Ceratina simillima* is widely distributed in India, mostly in the central and southern parts of the country, and in Sri Lanka.

DIAGNOSIS AND COMPARATIVE COMMENTS.—*Ceratina simillima* can be distinguished from other Indian *Ceratinidia* species by the presence of dense punctures on the area between the parapsidal furrow and the lateral margin of scutum. Male specimens have a unique truncate T7 with a small median point (Figure 186), and the distal part of the gonocoxite of the genitalia is narrowed and pointed.

VARIATIONS.—Not surprising considering its wide geographical range, this species exhibit many morphological variations. I have classified *C. simillima* into four morphs:

- I. “Typical morph” (Southern morph)—The specimens grouped into this population have many morphological characters agreeing well with the types of *C. simillima* and *C. eburneopicta*. This population is distributed from Maharashtra to every southern states of India. Detail description of this particular morph is provided in the subsequent section.
- II. Flavin morph—This population is found in the three southernmost states of India (Karnataka, Kerala, and Tamil Nadu). Although

sharing sympatry with the Southern morph population, the Flavin population can be easily distinguished by its smaller body size (5.55–7.00 mm.) and more yellow maculation on the body (the presence of a large yellow spot behind pronotal lobe is unique to this population). At most two rows of punctures along the outer side of the parapsidal furrow are not as dense as in the Southern morph.

III. Northern morph—This population is found in northern part of India (Himalchal Pradesh and Rajasthan). The yellow maculation and the size are as in the Southern morph; however, the area between the parapsidal furrow and the lateral margin of scutum is sparsely punctate.

IV. Sri Lanka morph—This morph is very similar to the Southern morph, but with more punctures on the frons and vertex.

All four morphs are based on female specimens. Male specimens of different morphs are similar to one another (including genitalic structure, S6, and T7 characters), with the exception of the Flavin morph whose maculation is more extensive than others.

DESCRIPTION (based on Southern morph; differences of other morphs are indicated under Variations)—**Female:** *Structure:* (1) Length 5.30–8.70 mm. Prosoma: (2) Clypeus usually with median longitudinal impressed area (in some specimens whole clypeus concave); lateral part of impressed area with dense small to medium-sized

punctures (sometimes scattered); lower part slightly rugose or smooth with sparse small to medium-sized punctures. (3) Labrum rugose with mixture of medium-sized and coarse punctures, and many short bristles. (4) Paraocular area below antennal fossa with dense small to medium-sized punctures (sometimes punctures scattered, not dense), mostly on median and lower part, few punctures on upper part of paraocular area. (5) Inner part of antennal fossa with dense coarse punctures along frontal carina, outer part impunctate or at most with few punctures. (6) Dorsolateral area of antennal fossa without smooth fovea. (7) Supraclypeal area below frontal carina with few scattered punctures. (8) Frons and vertex with dense and coarse punctures throughout. (9) Space between ocelli and upper part of compound eye with scattered coarse punctures. (10) Gena shiny, almost impunctate with few punctures on lower part. (11) Preoccipital carina somewhat prominent; area behind ocelli nearly flat. (12) Hypostomal area with rather dense medium-sized punctures (some specimens impunctate); hypostomal carina slightly prominent. Mesosoma: (13) Anterior portion of scutum with dense, medium-sized punctures; punctures continuing posteriorly along lateral margin and parapsidal furrow; posterior part of scutum densely punctate; small area between anteromedian line and parapsidal furrow impunctate. (14) Lateral margin of scutum lined with two or more rows of medium-sized punctures. (15) Procoxa with rounded angle on outer side at base. (16) Mesepisternum with dense coarse punctures laterally and ventrally; punctures slightly less dense posterolaterally near mesocoxal base. (17) Area around scrobe with conspicuous impunctate area (size varied). (18) Propodeal triangle coriaceo-reticulate

(some specimens with strong reticulation); lateral area of propodeum densely and finely punctate, without patch of dense hair on anterior part. Metasoma: (19)–(21) See male. *Maculations* (yellow except as noted): Prosoma: (22) Upper lobe of inverted-T marking on clypeus at most reaching 2/3 of clypeal length (Sri Lanka morph only reaching 1/2 of clypeal length); lateral arms of marking usually with small hooked point downward. (23) Labrum black. (24) Mandible black. (25) Supraclypeal spot well-developed. (26) Frontal spot well-developed. (27) Marking on paraocular area linear and curving inward below (hook-like) (some specimens with thin marking gradually widened from top to bottom) (Figure 38). (28) Genal marking slightly narrowed downward; extending 3/4 of eye length. (29) Base of antennal scape black. Mesosoma: (30) Transverse marking on pronotum often interrupted medially, rarely connected to yellow spot on pronotal lobe. (31) Spot behind pronotal lobe absent (except large in Flavin morph). (32) Scutum with four longitudinal lines. (33) Axilla black. (34) Tegula reddish-brown, translucent. (35) Scutellum usually with triangular marking (size varied); small incision on anterior margin of marking. (36) Marking on metanotum absent. (37) Protochanter and mesotrochanter with small marking at base apically. (38) Profemur black with yellow spots on outer and inner sides; inner side spot extending for half of femoral length. (39) Protibia and mesotibia dark brown to black with yellow marking on outer side extending 2/3 of tibial length distally from base (some specimens without extension of marking on mesotibia). (40) Metatibia black with yellow spot at base (sometimes marking extending distally for 2/3 of tibia length). (41) Tarsi ferruginous, yellow, or

black. (42) Metabasitarsus ferruginous, yellow, or black. Metasoma: (43) Metasomal bands more reduced than in other Indian *Ceratinidia* species; T1 with marking not enclosing two black spots, T2–T4 with bands usually interrupted medially (sometimes T2 and T4 bands unbroken), no band on T6

Male: As described for female except as follows: *Structure*: (1) Length 5.65–8.35 mm. Prosoma: (2) Clypeus with median longitudinal impressed area; lateral part of impressed area with small to medium-sized punctures (less dense than in female); lower part smooth (or superficially rugose) with few punctures. (3) Labrum nearly smooth with scattered small punctures; with few setae. (4) Paraocular area below antennal fossa with scattered small to medium-sized punctures. (5) Inner part of antennal fossa with dense, coarse punctures along frontal carina, outer part impunctate or at most with few punctures. (6) Dorsolateral area of antennal fossa with small invagination. (7) Supraclypeal area below frontal carina impunctate. (8) Frons with coarser and denser punctures. (9) Space between ocelli and upper part of compound eye with dense coarse punctures. (12) Hypostomal area with nearly dense, medium-sized punctures; hypostomal carina slightly prominent. Mesosoma: (13) Scutum with more punctures than in female. Metasoma: (19) S6 with medium-sized submedian tooth and small median projection on each side of subapical depression (in some specimens absent) (Figure 160); anterior part of S6 with rather dense, medium-sized punctures and stiff long bristles (no bristles near teeth); apical lobe prominent. (20) T7 apically truncate with small median pointed apex; lateral angle of T7 right

angle. (21) Distal part of gonocoxite narrowed and pointed at apex, with bristles along apical margin; inner margin of gonocoxite strongly angulated. *Maculations* (yellow except as noted): Prosoma: (22) Upper lobe of inverted-T marking on clypeus reaching 2/3 of clypeal length (in some of Sri Lanka morph only reaching 1/2 of clypeal length); lateral arms of marking well-developed, occupying almost entire lower part of clypeus. (23) Labrum yellow. (24) Mandible black. (25) Supraclypeal spot narrower than in female. (26) Frontal spot reduced, linear. (27) Marking on paraocular area with linear marking gradually widened from top to bottom (Figure 134). (28) Genal marking slightly narrowed downward, extending half of eye length. (29) Base of antennal scape black, but some specimens with yellow apex.

Mesosoma: (30) Transverse marking on pronotum barely connected to yellow spot on pronotal lobe. (31) Spot behind pronotal lobe absent. (35) Scutellum marking as in female, or in some specimens with small yellow spot. (38) Profemur black with yellow spots on outer and inner side; inner side spot extending for 2/3 of femur length. (39) Protibia and mesotibia dark brown to black with yellow marking on outer side extending for almost entire tibia length. (40) Metatibia black with yellow spot at base, extending distally for 2/3 of tibial length. (41) Tarsi ferruginous to yellow. (42) Metabasitarsus ferruginous to yellow. Metasoma: (43) Metasomal bands more reduced than in female; T1 with marking not enclosing black spots, T2–T4 with bands usually interrupted medially (sometimes T5 with band interrupted medially), no band on T7.

SPECIMENS EXAMINED IN ADDITION TO TYPES.—180 (145♀, 35♂).

INDIA. Himachal Pradesh: Tattapani, 600 m, 7 March 1990, L. Packer (1♂; **LAWRENCE-BAKER**), 8 March 1990, L. Packer (1♀; **LAWRENCE-BAKER**).
Karnataka: Bandipur National Park, 70 km SW of Mysore, 1,100 m, 16 August 1990, C. D. Michener (16♀, 9♂; **LAWRENCE**); Bangalore, 916 m, 25 March 1978, K. Ghorpade (1♀; **LAWRENCE**), 29 February 1984, K. Ghorpade (1♀; **LAWRENCE**), 11 March 1984, K. Ghorpade (4♀; **LAWRENCE**), 2 May 1984, K. Ghorpade (1♀; **LAWRENCE**), 8 May 1984, K. Ghorpade (1♀; **LAWRENCE**), 13 May 1984, K. Ghorpade (1♀; **LAWRENCE**), 30 May 1984, K. Ghorpade (3♀; **LAWRENCE**), 5 June 1984, K. Ghorpade (1♀; **LAWRENCE**), 22 August 1984, K. Ghorpade (1♀; **LAWRENCE**), 7 December 1985, K. Ghorpade (1♀; **LAWRENCE**), 11–20 April 1990, K. Ghorpade (1♀; **LAWRENCE**), 15 November 1990, K. Ghorpade (1♀; **LAWRENCE**), 30 November 1990, K. Ghorpade (1♀; **LAWRENCE**), 1,000 m, 18–19 August 1990, C. D. Michener (1♀; **LAWRENCE**); Biligiris, 1,100 m, 9 August 1977, Shashidhar (1♀; **LAWRENCE**); Jog Falls, 12 km S, 600 m, K. Ghorpade (1♀; **LAWRENCE**). Kerala: Kottayam District, Peermade, 4,200 ft, March 1975, T. R. S. Nathan (1♀; **LAWRENCE-BAKER**); Trivandrum District, Poonmudi Range, 3,000 ft, May 1992, T. R. S. Nathan (2♀, 1♂; **LAWRENCE-BAKER**), June 1992, T. R. S. Nathan (1♀, 1♂; **LAWRENCE-BAKER**); Wayalar Forests, 700 ft, September 1965, P. S. Nathan (1♂; **LAWRENCE**), October 1965, P. S. Nathan (1♀; **LAWRENCE**); 15 km N of Palai, 50 m, 2 November 1984, K. Ghorpade (1♀; **LAWRENCE**). Maharashtra: Lonauli near Poona, October to December 1974, F. L. Wain (2♀; **LOS ANGELES**);

Poona, October to December 1974, F. L. Wain (15♀; **LOS ANGELES**). Mysore: Coorg District, Mercara, 4,000 ft, May 1973, T. R. S. Nathan (1♀; **LAWRENCE-BAKER**), October 1973, T. R. S. Nathan (1♀; **LAWRENCE-BAKER**); Kakanakote Forest station, 8 January 1965, S. W. T. Batra (1♀; **LAWRENCE**); Shimoga District, Agumbe Ghat, 2,000 ft, May 1974, T. R. S. Nathan (1♀; **LAWRENCE-BAKER**).

Rajasthan: Udaipur, Saijan, Niwas Gdn., 8 April 1990, L. Packer (1♀; **LAWRENCE-BAKER**). Tamil Nadu: Anamalia Hills, Cinchona, 3,500 ft, March 1957, T. R. S. Nathan (3♀; **LAWRENCE-BAKER**); Coimbatore, 1,400 ft, November 1965, P. S. Nathan (2♀, **LAWRENCE**); Mudumalai Preserve, 3 km E of Theppakadu, 31 July 1990, W. T. Wcislo (2♀; **LAWRENCE**), 1,100 m, 5 km S of Theppakadu, 1–3 August 1990, W. T. Wcislo (2♀; **LAWRENCE**), 30 km NW of Udagamandalam, 16 August 1990, C. D. Michener (6♀, 1♂; **LAWRENCE**), 1,200 m, 30 km NW of Udagamandalam, 16 August 1990, C. D. Michener (29♀, 6♂; **LAWRENCE**); Nilgiri Hills, Cherangode, 3,500 ft, November 1950, P. Susai Nathan (3♀, 9♂; **LAWRENCE-BAKER**), Devala, 3,200 ft, April 1960, P. S. Nathan (1♀; **LOS ANGELES**), October 1960, P. S. Nathan (17♀; **LOS ANGELES**), May 1961, P. S. Nathan (1♀; **LOS ANGELES**); Pondicherry, Karikal, August 1972, T. R. S. Nathan (2♀; **LAWRENCE-BAKER**); South of Malabar District, Walayar Forests, August 1956, T. R. S. Nathan (2♀; **LAWRENCE-BAKER**), July 1957, T. R. S. Nathan (1♀; **LAWRENCE-BAKER**), August 1957, T. R. S. Nathan (2♀; **LAWRENCE-BAKER**); Tanjore District: Kurumbagaram, P. Susai Nathan (1♀; **LAWRENCE-BAKER**); 10 km NW of Udagamandalam, 2,000 m, 17 August 1990, C. D. Michener (2♀; **LAWRENCE**); 15

km NW of Udagamandalam, 1,500 m, 17 August 1990, C. D. Michener (1♀, 1♂;
LAWRENCE).

SRI LANKA. Anuradhapura: Kahalla Forest Reserve, Andiagala, 26 November
1987, B. M. P. Singhakumara (1♀; **LAWRENCE-BAKER**). Galkissa: 7 mi S of
Colombo, 4 May 1959, R. L. A. Perara (1♂; **LAWRENCE**). Laxapathiya: 13 mi S of
Colombo, 15–30 January 1959, R. L. A. Perara (1♀; **LAWRENCE**). Mediriginya: 21–
27 March 1958, R. L. A. Perara (1♂; **LAWRENCE**). Ratnapura: Sinharaja Forest
MAB Reserve, 8 March 1988, B. M. P. Singhakumara (1♀, 2♂; **LAWRENCE-
BAKER**), 16 June 1988, B. M. P. Singhakumara (3♀; **LAWRENCE-BAKER**).
Udugalla: 12 mi from Colombo, 15 February 1959, R. L. A. Perara (6♀, 1♂;
LAWRENCE).

Ceratina sutepensis Cockerell, new status

FIGURE 39, 73, 106, 135, 161, 187 (see Figure section at the end of text)

Ceratina lepida var. *sutepensis* Cockerell, 1929: 150 [Female]; van der Vecht, 1952:
54 [notes on type]

Ceratina lepida var. *sublepida* Cockerell, 1929: 150 [Female]; van der Vecht, 1952:
54 [notes on type] **new synonym**

TYPE MATERIAL.—The female type of *C. lepida* var. *sutepensis* in the Natural History Museum, **LONDON**, is labeled “*Ceratina lepida* var. *sutepensis* Ckll.”, “B.M. Type Hym. 14 b 220”, and “Doi Suthep, Siam”. The yellow maculation of this type is highly reduced, especially on the pronotum, pronotal lobe, mesoscutum, and mesepisternum. Since neither Cockerell nor subsequent authors designated the “type” (in Cockerell’s case) or lectotype (in van der Vecht’s case); I therefore designate as lectotype the female type of *C. lepida* var. *sutepensis* in **LONDON**, and add a red label “*Ceratina lepida* var. *sutepensis*, Lectotype, N. Warrit, 2007”.

The female type of *C. lepida* var. *sublepida* is similar to the type of *C. lepida* var. *sutepensis* in punctuation (note that of clypeus and paraocular area); however, the metasoma of the *C. lepida* var. *sublepida* type is missing. The type of *C. lepida* var. *sublepida* is labeled “*Ceratina lepida* var. *sublepida* Ckll.”, “Doi Sutep, Siam”, and “B.M. Type Hym. 14 b 222”. I designate as lectotype the female type of *C. lepida* var. *sublepida* in **LONDON**, and add a red label “*Ceratina lepida* var. *sublepida* Cockerell, Lectotype, N. Warrit, 2007”.

The types of *C. lepida* var. *sutepensis* and var. *sublepida* were both collected from the same area, Doi Suthep. The two names, originally “varieties” of *C. lepida*, were published simultaneously. As first reviser, I have selected *sutepensis* as the valid name. The difference between the two is only in the extent of yellow maculation, especially on the pronotum and scutellum. I am treating both “varieties” as one species.

DISTRIBUTION.—*Ceratina sutepensis* is known only from the mountainous area of Chiang Mai Province, Thailand.

DIAGNOSIS AND COMPARATIVE COMMENTS.—The female of *C. sutepensis* is similar to *C. bryanti*, but the yellow markings are much more reduced; especially on the pronotum, pronotal lobe, scutum, scutellum, and on the terga. The facial punctation of *C. sutepensis*, notably in the female, is unique among *Ceratinidia* except in the *bryanti* species-group. The pattern of punctation on the paraocular area is with fine to coarse punctures clumped together on the median part, and only few punctures present on lower and upper parts. The clypeus has a conspicuous median longitudinal impressed area; not as pronounced as in *C. hieroglyphica*.

The male of *C. sutepensis* is also similar to that of *C. bryanti* but with more reduced maculation. Markings on the following structures are absent in *C. sutepensis*, while present in *C. bryanti*: pronotal lobe, reduced transverse marking on pronotum, scutellum, hind tibia, and terga. The apex of T7 of both species is pointed with angulated margin, but in *C. bryanti* the apex is more produced with a conspicuous emargination (Figure 187).

DESCRIPTION—**Female:** *Structure:* (1) Length 7.70–9.80 mm. Prosoma: (2) Clypeus with median longitudinal impressed impunctate area; lateral area of impressed area with dense small to medium-sized punctures. (3) Labrum with mixture of medium-sized and coarse punctures and with many short bristles. (4) Paraocular area below

antennal fossa with medium-sized to coarse punctures clumping together on middle part, few punctures on lower part. (5) Inner part of antennal fossa with coarse punctures along frontal carina, outer part with few punctures. (6) Dorsolateral of antennal fossa area without smooth fovea. (7) Supraclypeal area below frontal carina with 1–2 punctures and ventral depression. (8) Frons and vertex with dense and coarse punctures. (9) Space between ocelli and upper part of compound eye with scattered coarse punctures. (10) Gena shiny almost impunctate. (11) Preoccipital carina prominent; area behind ocelli slightly flat. (12) Hypostomal area with scattered medium-sized punctures and setae; hypostomal carina slightly prominent.

Mesosoma: (13) Anterior third of scutum with dense medium-sized punctures; posterior two thirds of scutum shiny and impunctate except posterior margin; one row of punctures along anteromedian line. (14) Lateral margin of scutum lined with one or two rows of medium-sized punctures. (15) Procoxa with rounded angle on outer side at base. (16) Mesepisternum with dense coarse punctures laterally; punctures slightly less dense ventrally and posterolaterally near mesocoxa base; hypoepimeral surface convex in some specimens. (17) Area around scrobe with large oblique convex conspicuous impunctate area. (18) Propodeal triangle finely coriaceous-reticulate; lateral area of propodeum densely and finely punctate, without patch of dense hair anteriorly. Metasoma: (19)–(21) See male. *Maculations* (yellow except as noted): Prosoma: (22) Upper lobe of inverted-T marking on clypeus pointed (sometimes blunted), reaching half of clypeal length; lateral arms of marking with small hooked point downward. (23) Labrum black. (24) Mandible black. (25)

Supraclypeal well-developed. (26) Frontal spot oval. (27) Marking on paraocular area linear and curving inward along lower margin (hook-like) (Figure 39). (28) Genal marking slightly narrowed downward; extending half of eye length. (29) Base of antennal scape black. Mesosoma: (30) Transverse marking on pronotum interrupted medially (sometimes not interrupted), not connected to ferruginous spot (sometimes vaguely yellow) on pronotal lobe. (31) Spot behind pronotal lobe absent. (32) Scutum without yellow longitudinal line. (33) Axilla black. (34) Tegula dark reddish-brown translucent. (35) Scutellum black (some specimens with large marking narrowed posteriorly). (36) Marking on metanotum absent. (37) Protochanter and mesotrochanter usually with small yellow markings apically. (38) Profemur dark brown. (39) Protibia dark brown with yellow marking on outer side extending 2/3 of tibial length distally from base; mesotibia dark brown, at most with vague spot at base. (40) Metatibia dark brown. (41) Tarsi dark brown to black. (42) Metabasitarsus black. Metasoma: (43) Metasomal bands reduced; T1 without band or at most vague, T2 and T3 bands broadly interrupted medially, T4 and T5 bands unbroken, or in another common morph, T1 band not well-developed, other bands narrow but unbroken (sometimes T2 and T3 bands interrupted medially).

Male: As described for female except as follows: *Structure*: (1) Length 9.50–9.60 mm. Prosoma: (2) Clypeus with median longitudinal impressed impunctate area less conspicuous than in female; lateral part of impressed area with dense small to medium-sized punctures. (4) Paraocular area below antennal fossa with medium-

sized to coarse punctures clumping together on middle part, few punctures on lower part; punctures scattered along compound eye margin. Mesosoma: (13) Anterior third of scutum with dense medium-sized punctures; posterior two thirds of scutum shiny and impunctate except posterior margin; one of two rows of punctures along anteromedian line and parapsidal furrow. (14) Lateral margin of scutum lined with two or more rows of medium-sized punctures. Metasoma: (19) S6 with large submedian tooth and a small median projection on subapical depression (Figure 161); anterior part of S6 with coarse and dense punctures and stiff long bristles (no bristles near tooth); apical lobe prominent. (20) T7 apically pointed with prominent lateral angle. (21) Distal part of gonocoxite broad, with bristles along apical margin; inner margin of gonocoxite slightly round. *Maculations* (yellow except as noted): Prosoma: (22) Upper lobe of inverted-T marking on clypeus more developed than in female, apex of marking blunted, reaching half of clypeal length. (25) Supraclypeal spot more reduced than in female. (26) Frontal spot small, almost absent. (27) Marking on paraocular area linear but abruptly widened on margin near epistomal sulcus (Figure 135). Mesosoma: (30) Transverse marking on pronotum reduced to two small lateral spots; pronotal lobe without marking. (35) Scutellum black. (37) Protochanter and mesotrochanter without markings. Metasoma: (43) Metasomal bands almost absent; T4 and T5 with small remnants of markings.

SPECIMENS EXAMINED IN ADDITION TO THE TYPES.—6 (4♀, 2♂).

THAILAND. Chiang Mai: Ahn Kang, W. of Fang, 6 February 1993, S. Boongird, C. D. Michener, and S. Malaipan (1♀; **LAWRENCE**); Chiang Dao, 5–11 April 1958, T. C. Maa (1♀; **HONOLULU**); Doi Suthep, 22 April 1988, W. J. Pulawski (1♀; **SAN FRANCISCO**); Poi Suthee, 21 August 1990, G. W. Otis (1♀, 2♂; **LAWRENCE**).

Ceratina taiwanensis Shiokawa new status

FIGURE 40, 74, 107, 136, 162, 188 (see Figure section at the end of text)

Ceratina okinawana taiwanensis: Shiokawa, 1999: 264–265 [female and male descriptions]

TYPE MATERIAL.—The male holotype (not seen) in Hokkaido University, **SAPPORO**, is labeled “Holotype: ♂, Santimen, Pintung County, Taiwan, 3. V. 1976.”. The female paratype of *C. okinawana taiwanensis* is at the same institution as the holotype and is labeled “Santimen, Pingtung Pref., TAIWAN”, “1976.5.3 M. Shiokawa”, and “Paratype *Ceratina okinawana taiwanensis* Shiokawa, 1999”. The male paratype of *C. taiwanensis* from the same institution as above is labeled “Pinglin Taiwan 1974. 4. 27 T-26 M. Shiokawa”. Both paratypes are in excellent condition.

Ceratina taiwanensis was first described as a subspecies of *C. okinawana* from Taiwan and Fukien by Shiokawa (1999). Despite bearing many morphological resemblances to *C. okinawana* such as the pattern of punctation on the paraocular area and clypeus in the female, and lateral teeth with median denticle on the subapical

depression of S6 in the male, *C. taiwanensis* possesses conspicuous characters that appears to validate its status as a species separate from *C. okinawana*. One of the prominent characters that differentiates *C. taiwanensis* from *C. okinawana* is the concave apex of T7 in the male. Other characters including the less elevated hypostomal carina and extensive yellow maculation on the clypeus and legs also can be used to separate the two species.

DISTRIBUTION. —*Ceratina taiwanensis* is known from Taiwan and South China (Fukien).

DIAGNOSIS AND COMPARATIVE COMMENTS.—*Ceratina taiwanensis* closely resembles *C. okinawana*, and belongs to the bryanti species-group. It can be differentiated from *C. okinawana* by the unelluviated hypostomal carina and extensive yellow markings on the clypeus and mesotibia in the female and by the concave apex of T7 in the male.

DESCRIPTION—**Female:** *Structure:* (1) Length 6.80–8.60 mm. Prosoma: (2) Clypeus smooth, slightly rugose with small and medium-sized punctures mostly along dorsal and dorsolateral margins, median area superficially smooth (sometimes rugose); median impressed area present with vague median longitudinal carina. (3) Labrum smooth, superficially rugose, with few small punctures. (4) Paraocular area below antennal fossa with dense small to medium-sized punctures clumped together on

middle part, few punctures on lower part. (5) Inner part of antennal fossa with dense coarse punctures along frontal carina, outer part impunctate. (6) Dorsolateral part of antennal fossa area without smooth fovea. (7) Supraclypeal area below frontal carina impunctate. (8) Frons and vertex with dense and coarse punctures. (9) Space between ocelli and upper part of compound eye with less dense coarse punctures than vertex or frons. (10) Gena shiny with few scattered punctured. (11) Preoccipital carina not prominent; area behind ocelli slightly depressed. (12) Hypostomal area impunctate; hypostomal carina not prominent. Mesosoma: (13) Anterior third of scutum with dense medium-sized punctures; posterior two thirds of scutum shiny and impunctate except posterior margin; at least one row of punctures along anteromedian line and parapsidal furrow. (14) Lateral margin of scutum lined with one or two rows of medium-sized punctures. (15) Procoxa with rounded angle on outer side at base. (16) Mesepisternum with dense coarse punctures laterally and ventrally; punctures slightly less dense posterolaterally near mesocoxal base. (17) Area around scrobe with conspicuous impunctate area. (18) Propodeal triangle finely coriaceo-reticulate; lateral area of propodeum densely and finely punctate, with small patch of dense hair anteriorly. Metasoma: (19)–(21) See male. *Maculations* (yellow except as noted): Prosoma: (22) Inverted-T marking on clypeus well-developed, occupying almost entire area except dorsolateral margin; upper lobe of marking almost reaching frontoclypeal sulcus. (23) Labrum black. (24) Mandible black (sometimes with vague spot at base). (25, 26) Supraclypeal and frontal spots well-developed. (27) Marking on paraocular area linear and curving inward along lower margin (hook-

like), thicker than in related species (Figure 40). (28) Genal marking slightly narrowed downward; extending for almost entire length of eye; hypostoma with small vague spot near lateral arm of hypostomal carina (sometimes absent). (29) Base of antennal scape dark brown; apex sometimes with small yellow spot. Mesosoma: (30) Transverse marking on pronotum connected to yellow spot on pronotal lobe. (31) Spot behind pronotal lobe present, or absent. (32) Scutum with four longitudinal lines. (33) Axilla often with yellow spot. (34) Tegula reddish-brown translucent sometimes with small yellow spot. (35) Scutellum with rectangular marking, slightly narrowed posteriorly; small incision on anterior margin of marking. (36) Marking on metanotum usually present. (37) Protrochanter and mesotrochanter without markings apically. (38) Profemur dark brown with yellow spot on inner side, extending for half of femoral length. (39) Protibia ferruginous with yellow marking on outer side extending for 2/3 to almost entire length of tibia; mesotibia dark brown with small yellow spot at base, extending for 1/2 of tibial length. (40) Metatibia with yellow spot at base, extending 1/4 to 1/2 of tibial length. (41) Tarsi ferruginous. (42) Metabasitarsus dark brown to black. Metasoma: (43) Metasomal bands well developed and unbroken; no band on T6; T1 with wide marking almost or enclosing two black spots.

Male: As described for female except as follows: *Structure*: (1) Length 6.50–8.60 mm. Prosoma: (2) Clypeus smooth with few small punctures. (3) Labrum smooth with few small punctures. (4) Paraocular area below antennal fossa smooth with

small punctures clumping together on middle part, no punctures on lower part. (6) Hypostomal area with scattered small punctures; hypostomal carina not prominent.

Mesosoma: (13) Anterior third of scutum with dense medium-sized punctures; posterior two thirds of scutum shiny and impunctate except posterior margin; one row of punctures along median line; dense punctures on outer and inner sides of parapsidal furrow (denser than in female), thus reducing impunctate area (some specimens as in *C. o. okinawana*). (14) Lateral margin of scutum lined with two or more rows of medium-sized punctures. (16) Mesepisternum with dense coarse punctures through out. Metasoma: (19) S6 with medium-sized submedian tooth and small median projection on subapical depression; median projection with median incision (Figure 162); anterior part of S6 with medium-sized, dense punctures and stiff long bristles (no bristles near tooth); apical lobe prominent. (20) T7 apically concave; lateral angle of T7 rounded. (21) Distal part of gonocoxite broad at apex, with bristles along apical margin; inner margin of gonocoxite somewhat angularly protrudent. *Maculations* (yellow except as noted): Prosoma: (22) Inverted-T marking on clypeus well-developed, occupying entire area. (23) Labrum yellow. (24) Mandible black with small spot at base. (25) Supraclypeal spot well-developed. (26) Frontal spot reduced, sometimes reduced to small spot. (27) Marking on paraocular area linear above, then abruptly widened and occupying entire area of lower and median parts (Figure 136). (28) Genal marking slightly narrowed downward; extending along half of eye length; hypostoma without small vague spot near lateral arm of hypostomal carina. (29) Base and apex of antennal scape often with yellow

spot. Mesosoma: (30) Transverse marking on pronotum often connected to yellow spot on pronotal lobe. (31) Spot behind pronotal lobe absent. (32) Longitudinal lines on scutum varied (absent, two lines, or four lines). (33) Axilla black. (34) Tegula reddish-brown translucent. (35) Scutellum with rectangular marking, slightly narrowed posteriorly; small incision on anterior of marking. (36) Marking on metanotum absent. (37) Protrochanter and mesotrochanter with small spots at apices. (38) Profemur dark brown with yellow spot on inner side, extending for entire length of femur. (39) Protibia and mesotibia with yellow markings on outer sides extending for entire lengths of tibiae. (40) Metatibia yellow. (41) Tarsi ferruginous to yellow. (42) Metabasis yellow. Metasoma: (43) Metasomal bands more reduced than in female; T1 band not enclosing two black spots (sometimes marking vague), T2 and T3 bands interrupted medially, T4 and T5 bands unbroken or sometimes slightly interrupted medially, no bands on T6 and T7.

SPECIMENS EXAMINED IN ADDITION TO TYPES.—10 (6♀, 4♂).

TAIWAN. Kentin Prefecture: 7 May 1980, M. Shiokawa (2♀; **SAPPORO - SHIOKAWA**), 8 May 1980, M. Shiokawa (1♀, 2♂; **SAPPORO -SHIOKAWA**).

Pingtung Prefecture: Santimen, 3 May 1976, M. Shiokawa (3♀, 2♂; **SAPPORO - SHIOKAWA**).

Ceratina takasagona Shiokawa and Hirashima

FIGURE 41, 75, 108, 137, 163, 189 (see Figure section at the end of text)

Ceratina takasagona Shiokawa and Hirashima, 1982: 178–181 [male and female];
Wu, 2000: 174–175 [record from China].

TYPE MATERIAL.—The male holotype in Kyushu University, Japan, **FUKUOKA**, is labeled “Type No. 2383, Meishan, 864 m., Taiwan, 9. IX. 1979 (Y. Hirashima)”. I have not examined any of the type specimens, but material examined was kindly provided by Mr. Masato Shiokawa, who is one of the authors of *C. takasagona*.

DISTRIBUTION.—*Ceratina takasagona* is only known from Taiwan

DIAGNOSIS AND COMPARATIVE COMMENTS.—*Ceratina takasagona* closely resembles to *C. flavipes*, but has more extensive yellow maculation (Figure 41). The preoccipital carina of both sexes of *C. takasagona* is more distinct than in *C. flavipes* (in male more conspicuous than in female). In the female *C. takasagona*, the clypeus is not coarsely sculptured, the median longitudinal ridge on the clypeus is sharp and distinct, and the paraocular area below the antennal fossa is shiny with at most 3–5 small punctures. The submedian teeth on the subapical depression of S6 in the male of *C. takasagona* more or less straight, not bent outward as in *C. flavipes*. Shiokawa and Hirashima (1982) suggested that the submedian teeth on S6 of *C. takasagona* are closer together than in *C. flavipes*; however, submedian teeth on some specimens of *C. takasagona* are as far apart as in *C. flavipes*.

DESCRIPTION—**Female:** *Structure:* (1) Length 5.55–8.60 mm. Prosoma: (2) Clypeus smooth, superficially rugose; scattered small punctures along margins, mostly on upper and upper lateral parts; median impressed area and median longitudinal carina present. (3) Labrum with dense small and medium-sized punctures and some bristles. (4) Paraocular area below antennal fossa shiny almost impunctate with few small punctures. (5) Inner part of antennal fossa with sparse medium-sized punctures along frontal carina, outer part impunctate. (6) Dorsolateral area above antennal fossa without small smooth fovea. (7) Supraclypeal area below frontal carina impunctate. (8) Frons with scattered large shallow punctures; vertex with more punctures but not dense. (9) Space between ocelli and upper part of compound eye almost impunctate, at most with few punctures. (10) Genal area shiny, impunctate. (11) Preoccipital carina prominent; vertex behind ocelli depressed. (12) Hypostomal area impunctate. Mesosoma: (13) Anterior fourth of scutum fairly densely punctate with small punctures; posterior three fourths densely punctured; along anteromedian line with few or one row of punctures; fewer or no punctures along parapsidal furrow. (14) Lateral margin of scutum lined with one or two rows of small punctures. (15) Procoxa with rounded angle on outer side at base. (16) Mesepisternum with sparse medium-sized punctures laterally and ventrally (interspaces larger than punctures diameter); less dense posterolaterally near mesocoxal base; large impunctate area on hypoepimeral area; mesepisternum with dense long bristles. (17) Area around scrobe with large conspicuous impunctate area. (18) Propodeal triangle finely coriaceous-

reticulate; lateral area of propodeum densely and finely punctate, without patch of dense hair anteriorly. Metasoma: (19)–(21) See male. *Maculations* (yellow except as noted): Prosoma: (22) Upper lobe of inverted-T marking on clypeus reaching 2/3 of clypeal length; lateral arm well-developed. (23) Labrum black. (24) Mandible black. (25) Supraclypeal spot well-developed. (26) Frontal spot near frontal carina well-developed. (27) Marking on paraocular area thick, gradually widened from top to bottom (Figure 41). (28) Genal marking streak-like; short. (29) Base of antennal scape dark brown to ferruginous. Mesosoma: (30) Transverse marking on pronotum connected to yellow spot on pronotal lobe. (31) Spot behind pronotal lobe large. (32) Scutum with four longitudinal lines. (33) Axilla black. (34) Tegula often reddish brown. (35) Scutellum with triangular marking, narrowed posteriorly; anterior margin of marking with small incision. (36) Marking on metanotum present. (37) Protochanter and mesotrochanter usually with vague markings apically. (38) Profemur dark brown with yellow spots at apex, extending basad for entire length of femur. (39) Protibia and mesotibia ferruginous with yellow markings on outer side extending for entire length of tibiae. (40) Metatibia dark brown with yellow spot at base, extending distally for entire length of tibia. (41) Tarsi ferruginous to yellow. (42) Metabasitarsus yellow. Metasoma: (43) Metasomal bands well-developed; T1 band almost enclosing two small black spots (sometimes enclosing), T2–T5 bands unbroken, no band on T6.

Male: As described for female except as follows: *Structure:* (1) Length 5.95–6.20 mm. Prosoma: (2) Clypeus smooth with few small punctures along margin; median impressed area and median longitudinal carina present. (3) Labrum smooth with few scattered small punctures. (4) Paraocular area below antennal fossa smooth, almost impunctate. (5) Inner part of antennal fossa with rather dense, medium-sized punctures along frontal carina, outer part impunctate. (6) Dorsolateral area of antennal fossa with small smooth fovea. (8) Frons with more long bristles. (10) Genal area shiny, almost impunctate, with few scattered punctures. Mesosoma: (13) Anterior portion of scutum with more scattered hairs than in female. Metasoma: (19) S6 with long submedian teeth (three times longer than wide) on subapical depression (Figure 163); anterior part of S6 with medium-sized and dense punctures and stiff long bristles (no bristles near tooth); apical lobe prominent. (20) T7 apically pointed slightly truncate; lateral angle of T7 rounded bent inward. (21) Distal part of gonocoxite broad at apex, with bristles along apical margin; inner margin of gonocoxite rounded. *Maculations* (yellow except as noted): Prosoma: (22) Inverted-T marking on clypeus well-developed, occupying entire area except margin. (23) Labrum yellow. (24) Mandible black with yellow marking at base. (26) Frontal spot near frontal carina reduced to small spot or absent. (27) Marking on paraocular area well-developed, occupying entire area except margin (Figure 137). (28) Genal marking streak-like; longer than in female, sometimes interrupted medially. (29) Base of antennal scape dark brown to ferruginous, apex yellow. Mesosoma: (30) Transverse marking on pronotum connected (sometimes barely) to yellow spot on

pronotal lobe. (31) Spot behind pronotal lobe present, smaller than or as large as in female. (32) Scutum often with four longitudinal lines (sometimes with only outer lines). (36) Marking on metanotum absent. (37) Protrochanter and mesotrochanter with markings apically. (38) Profemur dark brown with yellow spots at apex, extending basad for entire length of femur. (39) Protibia and mesotibia ferruginous with yellow markings on outer sides extending for entire lengths of tibiae. (40) Metatibia dark brown with yellow spot at base, extending distally for entire length of tibia. (41) Tarsi yellow. (42) Metabasisarsus yellow. Metasoma: (43) Metasomal bands slightly more reduced than in female; T1 band almost enclosing two small black spots, T2, T4, and T5 bands unbroken or slightly interrupted medially, T3 broadly interrupted (or sometimes unbroken), no band on T7.

SPECIMENS EXAMINED IN ADDITION TO TYPES.—6 (3♀, 3♂).

TAIWAN. Nansanchi: 24 April 1974, M. Shiokawa (1♀; **SAPPORO -SHIOKAWA**).
Wushe: 24 April 1974, M. Shiokawa (1♂; **SAPPORO -SHIOKAWA**), 25 April 1974,
M. Shiokawa (2♂; **SAPPORO -SHIOKAWA**), 27 April 1976, M. Shiokawa (2♀;
SAPPORO -SHIOKAWA).

Ceratina tropica Crawford

FIGURE 42, 76, 109, 138, 164, 190 (see Figure section at the end of text)

Ceratina tropica Crawford, 1910: 119 [female]; Cockerell, 1911: 636 [mentioned in key]; Cockerell, 1918: 142 [new records in Luzon and Mindanao, Philippines]; Cockerell, 1920a: 146 [new record for Culasi, Philippines]; Cockerell, 1925a: 54 [new record in Bangui, Ilocos Norte, Philippines]; van der Vecht, 1952: 62–64 [redescription of female and male, and indicated synonyms].

? *Ceratina mcgregori* Cockerell, 1925a: 54–55 [male; based on a specimen from Solsona, Ilocos Norte; type unknown or lost].

? *Ceratina luzonica* Hedicke, 1926: 419 [females; based on specimens from Mangarin, Mindoro and Bayombong, Luzon].

TYPE MATERIAL.—The female holotype of *C. tropica* at the United States National Museum of Natural History, The Smithsonian's Institutions, **WASHINGTON, D.C.** is labeled “Manila PI”, “Type No 12885 U.S.N.M.”, and “Robt Brown collector”. The type has two vague longitudinal lines on scutum and is in good condition.

Van der Vecht (1952) synonymized *C. mcgregori* and *C. luzonica* with *C. tropica*. *Ceratina mcgregori*, according to Cockerell's description (1925), does not appear to differ in coloration from male *C. tropica*. Cockerell stated that the upper lobe of the clypeal marking of *C. mcgregori* is broader than in *C. tropica*, and mentioned other color characters, which do not separate it from the male of *C. tropica*. Both van der Vecht and the author did not know the present location of the type of *C. mcgregori* (Cockerell did not indicate where the type was deposited).

I have not seen the female type of *C. luzonica* Hedicke. Van der Vecht (1952) did not provide an explanation for his treatment of *C. luzonica* in his revision.

Therefore, I follow van der Vecht's treatment for the name *C. luzonica* as a synonym of *C. tropica* for the time being.

DISTRIBUTION.—*Ceratina tropica* is recorded from throughout the major Philippine Islands (e.g., Luzon, Mindoro, and Mindanao).

DIAGNOSIS AND COMPARATIVE COMMENTS.—*Ceratina tropica* can be distinguished from other *Ceratinidia* species by the presence of a swollen (convex) and impunctate dorsolateral area above antennal fossa, adjacent to the upper margin of compound eye, and by the densely punctate clypeus (sometimes strongly rugose), paraocular area, frons, and vertex. However in smaller specimens (less than 6.50 mm.) of both sexes (or even in larger males), the swollen area might not be easily recognized; as a result *C. tropica* comes out in two places in the key to female. Maculation and facial punctation can be valuable in identifying this species. In the female *C. tropica*, the marking on the paraocular area below the antennal fossa is usually divided into two small spots; one near the epistomal sulcus, and the other near the margin of the compound eye. The inverted-T marking on the clypeus is with the upper lobe small, almost absent. In the male, the marking on the paraocular area is not divided and the upper lobe of the clypeal marking is sometimes about twice as long as in the female.

The male of *C. tropica* has two lateral teeth and a median denticle on the subapical depression of S6.

DESCRIPTION—**Female:** *Structure:* (1) Length 5.70–8.85 mm. Prosoma: (2) Clypeus rugose; lateral and upper areas with coarse punctures, other parts more or less densely punctured except median area; median area ventrally with broadly depressed area (sometimes with narrow median longitudinal invagination). (3) Labrum with mixture of medium-sized and coarse punctures, and with some short bristles. (4) Paraocular area below antennal fossa with slightly dense well defined punctures (interspaces larger than puncture diameter). (5) Inner part of antennal fossa with dense coarse punctures along frontal carina, outer part with scattered coarse punctures; dorsolateral area adjacent to compound eye impunctate and swollen (convex), larger specimens from Mindanao with this area swollen, with fewer punctures than in typical specimens. (6) Dorsolateral part of antennal fossa area without smooth fovea. (7) Supraclypeal area below frontal carina impunctate or at most with 1–2 punctures, and with ventral depression. (8) Frons and vertex with scattered and clumped coarse punctures above antennal fossa throughout. (9) Space between ocelli and upper part of compound eye with scattered coarse punctures. (10) Genal area with scattered coarse punctures (sometimes dense), except larger specimens from Mindanao with scattered shallow punctures. (11) Preoccipital carina not prominent; area behind ocelli slightly depressed. (12) Hypostomal area with scattered coarse punctures. Mesosoma: (13) Anterior portion of scutum with dense medium-sized punctures

extending along anterior part of parapsidal furrow; posterior area with dense punctures; area between lateral margin and parapsidal furrow densely punctate; area between two parapsidal furrows impunctate except row of punctures on each side of anteromedian line. (14) Lateral margin of scutum lined with two or more rows of medium-sized punctures. (15) Procoxa with round angle on outer side at base. (16) Mesepisternum with dense coarse punctures throughout. (17) Area around scrobe with conspicuous impunctate area. (18) Propodeal triangle finely coriaceous-reticulate; lateral area of propodeum densely and finely punctate, with small patch of dense hair anteriorly. Metasoma: (19)–(21) See male. *Maculations* (yellow except as noted): Prosoma: (22) Upper lobe of inverted-T marking on clypeus not well developed, often incised on upper margin; lateral arm of marking with small lobe distally. (23) Labrum black. (24) Mandible black. (25) Supraclypeal spot well-developed. (26) Frontal spot irregular, sometimes oval or rectangular. (27) Marking on paraocular area divided into two small spots, one on lower margin, the other near compound eye (Figure 42). (28) Genal marking slightly narrowed downward; extending 2/3 to almost entire length of eye. (29) Base of antennal scape ferruginous. Mesosoma: (30) Transverse marking on pronotum often medially interrupted and only rarely connected (sometimes via thin yellow line) to yellow spot on pronotal lobe. (31) Spot behind pronotal lobe often small or absent. (32) Scutum often without yellow longitudinal lines or only with vague inner line (sometimes with four longitudinal lines). (33) Axilla black. (34) Tegula dark reddish-brown translucent (sometimes with small yellow spot). (35) Scutellum with large marking, narrowed posteriorly;

anterior margin of mark with small incision. (36) Marking on metanotum absent (sometimes vaguely present). (37) Protrochanter and mesotrochanter usually each with faint yellow marking apically. (38) Profemur dark brown with two yellow spots at base, on opposite sides and not connected. (39) Protibia dark brown with yellow marking on outer side extending 2/3 to almost entire tibial length distally from base; mesotibia dark brown. (40) Metatibia dark brown, sometimes with small yellow spot at base. (41) Tarsi dark brown. (42) Metabasitarsus dark brown. Metasoma: (43) Metasomal bands narrow, more or less developed; T1 band not enclosing dark spots, often not well developed, T2, T3 and T4 bands interrupted medially (sometimes T2 band unbroken), no band on T6.

Male: As described for female except as follows: *Structure*: (1) Length 7.30–7.65 mm. Prosoma: (2) Clypeus slightly less rugose than in female; lateral and upper area with coarse punctures; median area with broadly depressed; median longitudinal carina vague. (4) Paraocular area below antennal fossa with slightly less dense coarse punctures. (5) Swollen (convex) area between compound eye margin and antennal fossa not as prominent. (7) Supraclypeal area below frontal carina densely punctate. Mesosoma: (13) Scutum with more punctures. Metasoma: (19) S6 with submedian tooth and small median denticle on subapical depression (Figure 164); anterior part of S6 with coarse and dense punctures and stiff long bristles, no bristles near denticle and lateral areas; apical lobe prominent. (20) T7 apically slightly pointed, not emarginate, with slightly angulate edges. (21) Distal part of genitalia somewhat

broad, with bristles along apical margin; inner margin of gonocoxite slightly angulate.

Maculations (yellow except as noted): Prosoma: (22) Upper lobe of inverted-T marking on clypeus rarely reaching mid length of clypeus; lateral arms with small hook pointing downward. (23) Labrum with yellow spot. (25) Supraclypeal spot well-developed. (26) Frontal marking reduced to small spot. (27) Marking on paraocular area more developed, widened from top to bottom (Figure 138). (28) Genal marking slightly narrowed downward; extending 1/4 to half of eye length.

Mesosoma: (35) Scutellum with large marking, narrowed posteriorly (sometimes reduced to triangular shape); anterior margin with small incision. (38) Profemur dark brown with two yellow spots at apex, on opposite sides and not connected; inner side spot longer than in female. (39) Mesotibia dark brown with at most yellow at base. (40) Metatibia dark brown, sometimes with yellow spot at base extending 1/4 of tibia length. (41) Tarsi ferruginous yellow. (42) Metabasitarsus ferruginous to yellow.

Metasoma: (43) Metasomal bands reduced; T1 with vague marking, T2 and T3 bands widely interrupted medially, T4 bands slightly interrupted medially, T5 and T6 fully developed, no band on T7.

SPECIMENS EXAMINED IN ADDITION TO TYPES.—16 (12♀, 4♂).

PHILIPPINES. Culasi Panay: June 1918, McGregor (1♀; **LAWRENCE**). Luzon: Albay, Libon, Cagascos, 10 May 1965, 200 m, H.M. Torrevillas (1♀; **HONOLULU**), 18 May 1965, 200 m, H.M. Torrevillas (1♂; **HONOLULU**); Batangas, Lian Vicinity, 19–27 July 1986, C.K. Star (1♀; **LAWRENCE**); Los Baños, 1913, Ledyard (1♀; **LOS**

ANGELES); Mt. Montalban: Rizal, Wa-wa Dam, 25 February 1965, 150–200 m, H.M. Torrevillas (1♂; **HONOLULU**), 3 March 1965, 150–200 m, H.M. Torrevillas (1♂; **HONOLULU**), 10 March 1965, 150–200 m, H.M. Torrevillas (1♀; **HONOLULU**); Subic Bay, Grande Island, 7 October–15 November 1967, C.E. Goodpasture (2♀; **LOS ANGELES**). Mindanao: Dava City, Bago Oshiro, 9 April 1992, S.G. Reyes (2♀, 1♂; **LAWRENCE**). Mindoro: San José, October 1945, F.E. Skinner (3♀; **LOS ANGELES**).

CHAPTER 3 CLADISTIC ANALYSIS OF *CERATINIDIA*

INTRODUCTION

Evolutionary relationships among organisms can be depicted diagrammatically by phylogenetic trees. The linkage between these organisms is genealogical descent. All phylogenetic trees are composed of species or higher taxa represented by their (hypothesized or actual) ancestral evolutionary species (Wiley, 1981). A phylogenetic tree is one kind of dendrogram, a branching diagram connecting entities linked by some criteria (Mayr et al., 1953). The criteria used to infer the historical connections between taxa are synapomorphies. A dendrogram that portrays the diverging history of taxa, where the branching is based on the evidence of synapomorphies, is called a cladogram or historical dendrogram. Most phylogeneticists considered cladograms as phylogenetic trees justified by synapomorphic characters, sometimes challenged and criticized by some authors (e.g., Platnick, 1977; Tattersall and Eldredge, 1977). The purpose of this chapter is to resolve or hypothesize the evolutionary relationships among *Ceratinidia* species, to recognize and justify the species-groups, to test the monophyly of the group, and to make any inferences regarding character evolution and biogeography of *Ceratinidia*. The cladistic approach is used to generate the cladograms or phylogenetic trees of *Ceratinidia* species.

A morphological subgeneric-level phylogeny of *Ceratina* was proposed by Terzo (2000) based on 51 morphological characters of male and female bees. The phylogeny showed eight Oriental *Ceratina* subgenera to be in one clade except for *Pithitis*, and included one New World subgenus, *Ceratinula*, in the Oriental clade. In

the analyses of Terzo (2000), *Ceratinidia* is monophyletic and is placed as the sister taxon to subgenera *Xanthoceratina* and *Liocertina*. However, Terzo's analyses included only three species of *Ceratinidia* (*C. bryanti*, *C. nigrolateralis*, and *C. flavipes*), and the characters that supported the monophyly of *Ceratinidia* are not unique synapomorphies, but reversal characters (2 characters: decrease in the density of punctation on face and the absence of the supra-antennal furrow). In the present study, I have included 31 species of *Ceratinidia* described in Chapter 2 and five selected outgroups (all belonging to *Ceratina*).

MATERIALS AND METHODS

As noted above, 36 taxa, including five outgroup taxa, were used in the analysis. The species used as outgroup taxa belong to subgenera *Lioceratina* (*C. flavolateralis* Cockerell, 1916), *Neoceratina* (*C. dentipes* Friese, 1914), *Pithitis* (*C. smaragdula* Fabricius, 1787 and *C. binghami* Cockerell, 1910), and *Xanthoceratina* (*C. cladura* Cockerell, 1919a). Criteria used for choosing outgroups were based on subgeneric the phylogeny of the genus *Ceratina* (Terzo, 2000), where *Lioceratina* and *Xanthoceratina* were placed as sister taxa to *Ceratinidia*, *Neoceratina* was more distantly related, and *Pithitis* was the farthest. Of all 37 *Ceratinidia* species, only 31 were selected for the analyses, excluding *C. Chiangmaiensis*, *C. coptica*, *C. demotica*, *C. hieroglyphica*, *C. maai*, and *C. papuana*, because of lack of information on the male terminalia and genitalic structures and some female characters. Some characters used in the analyses were taken or modified from those discussed by Terzo (2000). An annotated list of the 120 characters and the data matrix used in the phylogenetic reconstructions can be found in Appendices I and II. Five characters are multi-state. Missing data are coded as “?”. All characters are unweighted and non-additive. The plesiomorphic state was not identified a priori and thus character state zero does not imply plesiomorphy.

The matrix was constructed in WinClada, version 1.00.08 (Nixon, 2002). The phylogeny was created in NONA (Goloboff, 1993) using an unconstrained heuristic search [Multiple TBR+TBR (mult^xmax^x) search strategy]. The search parameters were 10,000,000 maximum trees to keep, 1000 replications, 1 starting tree per

replication, and 0 random time. Bootstrap (10,000 replications) and Bremer Support values that were calculated accompany the phylogeny.

The phylogenetic analyses were performed with four data sets: Data set I including all 120 characters (structural and maculation characters), Data set II including 77 structural characters (excluding all maculation characters), Data set III including 43 maculation characters (excluding all structural characters), and Data set IV including selected structural and maculation characters (84 characters; see Appendix I). The objective for selecting the characters in data set IV is to eliminate probably correlated characters (e.g., the increase in punctuation on the anterior third of the scutum is positively correlated with the increase of punctures on the posterior fifth of the scutum, or the presence of a transverse yellow marking on the pronotum increases with the presence of well-developed markings on the tibiae). The selection of the correlated characters was subjective.

RESULTS

In the phylogenetic analysis of *Ceratinidia* using data set I (all 120 characters), a heuristic search found four equally parsimonious trees (TL = 645, CI = 0.33, RI = 0.53). The strict consensus of those trees (Figures 193 and 194-A–C; TL = 648, CI = 0.33, RI = 0.52) caused the collapse of two nodes. The monophyly of *Ceratinidia* is weakly supported statistically (Bootstrap value <50%, Bremer's value 1). All five outgroup taxa are excluded from the *Ceratinidia* clade. *Ceratina* (*Xanthoceratina*) *cladura* and *C. (Lioceratina) flavolateralis* are placed as sister taxa to *Ceratinidia*, as in the phylogeny created earlier by Terzo (2000). The position of the subgenera *Pithitis* (most basal) and *Neoceratina* (second most basal) is also in agreement with Terzo's topology. Nine synapomorphies were identified that unite *Ceratinidia* as a monophyletic taxon: character (15) medium-sized punctures along frontal carina, character (17) small invagination on dorsolateral area of antennal fossa (although reversed in some species), characters (20 and 24) coarse punctures on frontal and vertex areas (but the punctures are not as well-separated as in *Pithitis*), characters (35, 37, 45, 54) medium-sized punctures on anterior and posterior portions of scutum, mesepisternum, and metepisternum (in some species, the punctures are coarser or finer), and character (59) fine punctures of first metasomal tergum.

The most basal taxon in *Ceratinidia* is *C. takasagona* followed by *C. alpicola* (both without any synapomorphy support) and then followed by [*C. hieratica* [*C. accusator* [*C. pulchripes* [**B clade** + **C clade**]]]] (see Figure 193). The B clade is united by one synapomorphic character (character (63): V-shape ridge on subapical

depression of S6) with 57% bootstrap value and 4 Bremer's value. The C clade is without a unique synapomorphy but its species share a noteworthy symplesiomorphic character [character (63): submedian teeth on subapical depression of S6; except in *C. moderata*]. Clade C can be subdivided into three **subclades C-1, C-2, and C-3**. Subclade C-1 does not have a unique synapomorphic character, subclade C-2 is united by two unique synapomorphies [character (3) coarse punctures on clypeal area and character (22) swollen area on dorsolateral area of antennal fossa, except in *C. bicuneata*]; subclade C-3 with the exclusion of *C. simillima* and *C. litoraria* are united by the pattern of punctation on the median part of the paraocular area [character (12)]. The bootstrap value for subclade C-3 is less than 50%, but Bremer's value is 2.

The phylogeny produced by using data set II, including all 77 structural characters but excluding all maculation characters, yields in a substantially different topology. *Ceratinidia* is not a monophyletic group according to this analysis, but is paraphyletic (Bootstrap 66%, Bremer Support >20), including three outgroup subgenera: *C. (Neoceratina) dentipes*, *C. (Lioceratina) flavolateralis*, and *C. (Xanthoceratina) cladura*. A heuristic search found two equally parsimonious trees (TL = 417, CI = 0.36, RI = 0.57). The strict consensus of those trees (Figure 195; TL = 419, CI = 0.36, RI = 0.57) caused the collapse of two nodes. *Ceratina takasagona* and *C. alpicola* are not placed as the basal taxa of *Ceratinidia*, but are placed farther in the tree. The nearly equivalent subclades C-2 and C-3 from the previous analysis are at the base of this phylogeny. The three outgroup subgenera are sister taxa to *C. hieratica*, and are placed higher in the phylogeny. The species with a V-shaped ridge

on the subapical depression of male S6 are grouped together, as in B clade of data set I, with <50 % bootstrap and 3 Bremer values.

Using data set III, including all maculation characters (43 characters) and excluding all structural characters, a heuristic search found 18 equally parsimonious trees (TL = 172, CI = 0.37, RI = 0.62). The strict consensus of those trees (Figure 196; TL = 212, CI = 0.30, RI = 0.48) caused the collapse of 15 nodes; all this implies frequent convergence or parallelism in color patterns. *Ceratinidia* appears not to be a monophyletic group, but is paraphyletic (Bootstrap 62%, Bremer Support 6), including two other subgenera: *C. (Lioceratina) flavolateralis* and *C. (Xanthoceratina) cladura* (sister group to *C. collusor*). The consensus tree yields little information on the relationships among many *Ceratinidia* species (polytomy), and low statistical supports on almost every node. The basal taxa for this analysis are the Japanese and Korean species (*C. japonica*, *C. flavipes*, and *C. jejuensis*).

For the phylogenetic analysis using data set IV, including selected probably uncorrelated structural and maculation characters (84 characters), a heuristic search found 12 equally parsimonious trees (TL = 415, CI = 0.33, RI = 0.55). The strict consensus of those trees (Figures 197 and 198-A–C; TL = 423, CI = 0.32, RI = 0.54) caused the collapse of five nodes. *Ceratinidia* is not a monophyletic group according to this analysis, but paraphyletic (Bootstrap 72%, Bremer Support 4), including two outgroup subgenera: *C. (Lioceratina) flavolateralis* and *C. (Xanthoceratina) cladura* (as sister taxa to *C. rugosoclypeata*). Twelve synapomorphies are identified that unite “*Ceratinidia*” (including *Xanthoceratina* and *Liocertina*): character (20) coarse

punctures on frontal area, character (27) impunctate or few punctures on genal area (some species are with derived states, e.g., *C. punctigena*, *C. interrupta*), character (35) medium-sized punctures on anterior portion of scutum (in some species, the punctures are coarser or finer), character (50) partially dense punctures on scutellum, character (64) cone-shape or spine-like submedian teeth on the subapical depression of male S6 (replaced with V-shape ridge in some species), character (75) tuft of hair present on the apex of the male gonocoxite (absent in *Lioceratina*), character (79) well-developed lateral arm of the clypeal marking (reduced in some species), character (89) transverse marking on pronotum well-developed and unbroken (character state reversed in species with reduced marking), characters (111, 112) marking on T2 and T3 well-developed or slightly interrupted medially (character state derived in some species with reduced marking e.g., *C. accusator*), character (115) anterior portion of T1 nearly flat, character (117) color on pregradular and postgradular areas of T4 and T5 are different.

Continuing with comments on Data set IV, the basal clade on the phylogeny is united by one unique synapomorphy: coarse punctation on clypeus (character (3)). The four basal taxa, *C. bicuneata*, *C. tropica*, *C. carinifrons*, and *C. rugifrons*; are restricted to Southeast Asia. The following node is a polytomy for *Ceratina simillima*, *C. taiwanensis*, **Group D**, and **Clade E** (Figure 197). Group D is without a unique synapomorphy support (2 Bremer's value), and includes four morphologically similar species (*C. okinawana*, *C. lepida*, *C. bryanti*, and *C. sutepensis*), and a group of species from Japan and the Korea Peninsula. Clade E is supported by one unique

synapomorphy (character (12): sparsely punctate paraocular area below antennal fossa) and is divided into two subgroups **E-1** and **E-2**. subgroup E-1 is paraphyletic, including species with more reduced punctation mainly on facial structure and scutum than in Group D and the basal clade. The two outgroup subgenera, *Xanthoceratina* and *Lioceratina*, are included here with 12 unique synapomorphies (see Figure 198-B), 100% Bootstrap value and 12 Bremer's value. Subclade E-2 (53% Bootstrap value and 3 Bremer's value) comprises of all species with a V-shaped ridge on the subapical depression of male S6 (character (63)); however, the relationships among species in this subclade are mostly unresolved.

DISCUSSION

Interpretation of the Phylogeny and the Monophyly of Ceratinidia

The placement of the taxa in the tree derived from data set I (all 120 characters) is congruent with the subgeneric-level phylogeny proposed by Terzo (2000). *Ceratinidia* is a monophyletic group according to this analysis, and is closely related to the subgenera *Xanthoceratina* and *Lioceratina*. *Pithitis* and *Neoceratina* are the basal lineages. However, statistical support (both Bootstrap and Bremer's) for the monophyly of *Ceratinidia* is low, despite the presence of nine unique synapomorphies to support the clade. One possible explanation is that these nine unique synapomorphies are either positively or negatively correlated with one another; for example, in characters [synapomorphies] (35, 37, 45, 54), the presence of medium-sized punctures on the anterior and posterior portions of the scutum, mesepisternum, and metepisternum might be positively correlated to one another. Species that have medium-sized punctures on the anterior part of the scutum might always have medium-sized punctures on the other three areas. For cladistic analyses, characters should be independent of one another to prevent adding weight to the correlated characters and thereby reducing the relative weights of other independent characters (Mayr and Ashlock, 1991). In this case, I suspect that of the nine synapomorphies supporting the monophyly of *Ceratinidia*, only two or three are truly independent.

The other three phylogenies derived from data sets II–IV present substantially different tree topologies from the tree based on data set I. The topology created by

exclusively structural characters (77 characters; data set II) rejected the monophyly of *Ceratinidia*, including three outgroup subgenera (*Neoceratina*, *Xanthoceratina*, and *Lioceratina*) within the tree. The “*Ceratinidia*” branch is well supported with high statistical values (67% Bootstrap, > 20 Bremer’s), but most of the internal branches are poorly supported. Basal taxa are species with coarse and conspicuous punctation, mostly on facial structures, scutum, and mesepisternum, while species in the upper parts of the tree tend to have reduced punctation on those structures. Thus, the phylogeny implies that the large and coarse puncture size is a plesiomorphic state, and the reduction of the puncture size is derived. However, by neglecting the maculation characters in the analysis, it might be an erroneous to explain the evolution of the puncture size to be from larger to smaller in a linear manner. For example, *Ceratina* (*Neoceratina*) *dentipes* has its maculation entirely creamy white and its punctation highly reduced. Without including maculation characters into the analysis, one would probably find *C. dentipes*, a species from a different subgenus, included in *Ceratinidia*.

Of the four phylogenies created in this study, that obtained from data set III (the 43 maculation characters) yielded in a tree with the least resolution. This might be caused by the lower number of informative characters used in the analysis.

Xanthoceratina and *Lioceratina* are included in *Ceratinidia*, which makes *Ceratinidia* paraphyletic with fairly strong branch support (62% Bootstrap, 6 Bremer’s). The relationships among *Ceratinidia* species in this analysis are largely unresolved.

To combine both the structural and maculation characters in the phylogenetic analysis, data set IV was created to eliminate or reduce the number of correlated characters. Of 120 characters in data set I, only 84 characters were used, chosen to avoid the probability of the characters being highly correlated. The resultant phylogeny shows a more stable *Ceratinidia* clade than the other analyses (72% Bootstrap, 4 Bremer's), with fairly well resolved internal relationships among species (though still with low statistical branch support). The clade is supported with 12 unique synapomorphic characters (6 each for structural and maculation characters). However, the subgenera *Xanthoceratina* and *Lioceratina* are included in the *Ceratinidia* clade. Thus, if this phylogenetic hypothesis is accepted as showing the true ancestor-descendant relationships among *Ceratinidia* species, a new classification of *Ceratinidia* that includes *Xanthoceratina* and *Lioceratina* must be established.

The basal clade of the phylogeny (derived from data set IV) includes four Southeast Asian species: *C. bicuneata* (Java, Indonesia), *C. tropica* (Philippine Islands), *C. carinifrons* (Sulawesi, Indonesia), and *C. rugifrons* (Sulawesi, Indonesia). These bees are similar to one another in the presence of coarse and conspicuous punctation on their body parts. The sympatric species, *C. carinifrons* and *C. rugifrons*, superficially look alike. Both presumably inhabit the same niches, but can be differentiated from one another easily by the characters of the male S6. The following clade in the tree includes a polytomy of four lineages: *C. simillima*, *C. taiwanensis*, Group D, and Clade E. Group D, *C. simillima*, and *C. taiwanensis* are

discussed together since many of the species in these lineages are quite similar and share many common characters (though plesiomorphic). Group D is comprised of [*C. okinawana* + [[*C. lepida* + [*C. bryanti* + *C. sutepensis*]]] + [*C. japonica* + [*C. flavipes* + *C. jejuensis*]]]. The patterns of punctation and maculation on the clypeus and paraocular area below the antennal fossa are symplesiomorphic characters among species in Group D, *C. simillima*, and *C. taiwanensis* (clypeus rugose with conspicuous punctures along upper margin; marking on the clypeus rarely reaching half of clypeal length in female bees; clump of punctures on the median part of the paraocular area; and a hook-like marking on paraocular area in females). However, the maculations on clypeus and paraocular area are highly reduced in *C. japonica*, *C. flavipes*, and *C. jejuensis* from Japan and the Korean Peninsula. Another notable character shared among the three lineages is the cone-shaped or spine-like submedian teeth on the subapical depression of male S6, except in *C. japonica* and *C. jejuensis* whose submedian teeth are modified to become elongate and bent outward apically.

Clade E, which is artificially divided into subgroups E-1 and E-2, is united by the reduction of puncture density on the paraocular area. Subgroup E-1 (paraphyletic) contains a group of relatively small bees on the basal branches (*C. litoraria*, *C. accusator*, and *C. pulchripes*), followed by a unique species from Northern India, *C. moderata* (distinguished by two autapomorphies: character (44) sparsely punctate mesepisternum and character (63) bilobed process with submedian teeth on subapical depression of male S6). *Ceratina takasagona* and *C. alpicola* are placed after *C. moderata*. These two species were previously thought to be closely

related to *C. flavipes* and *C. japonica*, respectively, due to their presumably convergent similarities (Shiokawa and Hirashima, 1982; Shiokawa, 1999). But in this analysis, both *C. takasagona* and *C. japonica* are placed together and distant from *C. flavipes* and *C. japonica*. The reduction in puncture density and the increase of maculation in *C. takasagona* and *C. alpicola* grouped them together with other *Ceratinidia* species, thereby dissociating them from *C. flavipes* and *C. japonica* whose puncture density is greater and maculation more reduced. The last group of bees in subgroup E-1 includes *C. hieratica*, *C. rugosaclypeata*, *C. (Xanthoceratina) flavolateralis*, and *C. (Lioceratina) cladura*. This group contains bees with extensive maculations on their bodies. The geographical distributions of these bees make the group puzzling. *Ceratina hieratica* and *C. rugosaclypeata* are from the arid area from Western India to Afghanistan, while *C. flavolateralis* and *C. cladura* are representatives of the fauna from the tropical Southeast Asia (12 unique synapomorphies unite the last two species).

The monophyly of subgroup E-2 is supported by the presence of a V-shape ridge on the subapical depression of male S6. Species included in this subclade are restricted to the Southeast Asia region. Most of the relationships among species are unresolved (all supported characters are either homoplasious or reversals).

I consider that data set IV provides the most reliable information on relationships. Since analysis of this data set shows the “subgenera” *Xanthoceratina* and *Liocertina* to be part of group E1, I synonymized these names under *Ceratinidia*. Data sets II and III support this taxonomic decision.

Character Evolution in Males Sixth Sternum and the Species-Groups of

Ceratinidia

Van der Vecht (1952) divided *Ceratinidia* into two species-groups: the bryanti species-group and the compacta-species group, based upon the characters of the subapical depression of S6 of males. The bryanti species-group is characterized by the cone-shaped or spine-like submedian teeth, and the compacta species-group is characterized by the V-shaped ridge. Shiokawa and Hirashima (1982) later recognized a third species-group, the flavipes species-group, recognized by the elongate submedian teeth. Until now, all of these species-groups have been assigned to the subgenus artificially without knowing the phylogenetic relationships among *Ceratinidia* species and how this unique male S6 character has evolved. The presence of the submedian teeth on subapical depression of male S6 is shown to be a symplesiomorphic state in the phylogeny (Figure 199), while the V-shaped ridge and the elongate submedian teeth are derived states. Only *C. moderata* has a bilobed projection with lateral submedian teeth on its subapical depression (an autapomorphy). *Ceratinidia takasagona* and *C. flavipes* were previously considered to be closely related due to similarities in the elongate submedian teeth on the subapical depression of the male S6 (Shiokawa and Hirashima, 1982), but according to the phylogeny, the structures may be homoplasious. Moreover, they are quite different. The elongate submedian teeth in *C. flavipes* (also in *C. maai* and *C. jejuensis*) are bent outward apically and the distance between the teeth is 2–3 times

the width, whereas the elongate submedian teeth in *C. takasagona* are straight and the distance between the teeth is about the width of one of the teeth.

Ceratinidia is classified in this study according to the hypothetical phylogeny shown in Figure 199 (all characters, reduced for probable correlations, i.e., data set IV). Five species-groups are recognized, based especially on the features of S6 of the male: the tropica species-group (including 4 known species; *C. bicuneata*, *C. tropica*, *C. carinifrons*, and *C. rugifrons*), the bryanti species-group (including 6 known species; *C. simillima*, *C. taiwanensis*, *C. okinawana*, *C. lepida*, *C. bryanti*, and *C. sutepensis*), the flavipes species-group (including 3 known species; *C. flavipes*, *C. maai*, and *C. jejuensis*), the accusator species-group (including 8 known species; *C. litoraria*, *C. accusator*, *C. pulchripes*, *C. moderata*, *C. alpicola*, *C. takasagona*, *C. hieratica*, *C. rugosaclypeata*, and species from subgenera *Xanthoceratina* and *Lioceratina*), and the compacta species-group (including 10 known species; *C. lieftincki*, *C. collusor*, *C. nigrolateralis*, *C. compacta*, *C. cognata*, *C. jacobsoni*, *C. incertula*, *C. punctigena*, *C. interrupta*, and *C. malukuensis*). Additional *Ceratinidia* species that are not included in the phylogenetic analysis, but are treated taxonomically, are arbitrarily placed in the following species-groups based on their overall similarities: bryanti species-group (*C. hieroglyphica* and *C. coptica*), accusator species-group (*C. Chiangmaiensis* and *C. demotica*), and compacta species-group (*C. papuana*). In such cases, males are unknown or for other reasons important characters are unknown. Species formerly placed in the subgenera *Xanthoceratina* and *Lioceratina* were included (one each) in the phylogenetic study, but the species

are not included in the taxonomic part of this work. Finally, certain species that remain known to me only from descriptions, are listed with comments as appropriate under *Incertae Sedis* in the taxonomic part of this work.

Geographical Distribution, Dispersal, and Area of Endemism of Ceratinidia

Ceratinidia as a subgenus has a broad range of distribution in Asia from the arid area of Afghanistan to the temperate region of Japan and northeastern China and eastern Russia (from West to East), and from the Pacific maritime Russia to the tropical forest of Indonesia and western New Guinea (from north to south). The distribution covers three biogeographical areas of the world, the Paléarctic, the Oriental, and the Australasian regions. The Palearctic region where *Ceratinidia* is found comprises Afghanistan, the northern part of India in and near the Himalayas, Nepal, Japan, northeastern China, and the Primorskyi area of Russia. The Oriental region includes most of India, the Indochinese countries, Taiwan, southeastern China, the Malay Peninsula, much of the Indonesian Archipelago, and the Philippine Islands. The Australasian region includes Indonesia east of Bali, to western New Guinea. A summary of *Ceratinidia* species geographical distributions is shown in Figure 1 and Appendix III.

Ceratinidia diversity is highest in the Oriental region, particularly in the Southeast Asian countries, where vegetation ranges from subtropical to tropical rainforest with high relative humidity. Although Burma, Cambodia, and Vietnam have only one species reported from each, the low number of species must be a result

of little collecting. Extensive collecting in these areas will improve the knowledge of the endemic entomofauna; hence, increasing the number of *Ceratinidia* species.

Number of species gradually decreases as one moves away from Southeast Asia through the Indian subcontinent and the temperate region of eastern China, Korea, and Japan. India can be roughly divided into two *Ceratinidia* zoogeographical areas, the northern and the southern parts (this is not equivalent to the generally known “south Indian States” [Indian Peninsular states]). The northern part is restricted to the Himalayan region with high altitude and temperate climate. The species inhabiting this area are *C. lepida*, *C. moderata*, *C. demotica*, and *C. simillima*. The southern part of India, from Maharashtra to all Indian Peninsular states, has a tropical climate with a mixture of highlands and plateaus. The faunal and floral diversities in this area are high (the Southwestern Ghat Montane rain forest is considered to be one of the world’s biodiversity hotspots according to the World Wildlife Fund, Wikramanayake et al., 2002). *Ceratina simillima* (with three morphs), *C. coptica*, and *C. rugosaclypeata* are found in this region. Only one species, *C. hieratica*, is found in the arid area of Afghanistan, far northwest of India. This area may be the most western limit for the subgenus; the climate is cold during the winter (below freezing) and the summer dry.

Despite the fact that *Ceratinidia* is primarily a tropical bee subgenus, its range extends far beyond the Tropic of Cancer in the northern hemisphere. One temperate species, *Ceratina flavipes*, is found as far north as the Maritime Province of Primorskyi, Russia. *Ceratinidia* can be found along the eastern coast of China, as

well as the Korean Peninsula, and Japan. In eastern China and Taiwan, the climate is primarily influenced by monsoons and tropical storms, which create hot and humid weather for most of the year, except for the winter months. In addition, the topography of Taiwan in which with two thirds of the country mountainous might provide another dimension of niches *Ceratinidia* can thrive. In countries higher in latitude like Korea, Japan, northeastern China, and eastern Russia, the temperature during the winter months is well below 0° C, but summer monsoons can bring warmth and high humidity from the ocean, therefore creating a suitable climate for *Ceratinidia*. Bees in these high latitude areas can adapt to cold weather by hibernation during winter and can regulate body temperature and metabolism to withstand freezing temperatures (Sakagami et al., 1981). The weather north of Japan and Primorskyi is not influenced by the monsoons, thus has low humidity and colder temperatures during the year, apparently is not suitable for *Ceratinidia*.

In Southeast Asia, the bee extends beyond Wallace's line and Weber's line into Wallacea, including Sulawesi, Maluku Islands, Nusa Tenggara Islands, and Timor. *Ceratina papuana* is even found on the western New Guinea. Species that inhabit Wallacea tend to be endemic to their islands; for example, *C. rugifrons* and *C. carinifrons* are found only on Sulawesi, and *C. interrupta* and *C. malukuensis* are found only on the Maluku Islands. However, some species, such as *C. cognata*, can be found in Sulawesi and most of the islands that were connected to mainland Asia during the Pleistocene (the Sunda shelf: Java, Sumatra, Borneo, the Malay Peninsula, and Thailand). The broad distribution of *C. cognata* might be explained through

events of vicariance and dispersal. If *C. cognata* originated on mainland Asia and dispersed down to the Sunda shelf, then the increase in sea level after the ice age isolated *C. cognata* populations on islands in the Indonesian archipelago, except for Sulawesi. For *C. cognata* to be able to colonize Sulawesi, the bee had to disperse, which is not uncommon in bees that nest in stems or wood (Michener, 2000). Many reports have cited the possibility of stem-nesting bees colonizing isolated islands via both natural and human introductions of plant stems containing the resident bees. This hypothesis might be applicable to other species of *Ceratinidia* in the compacta species-group, which is endemic to the Southeast Asian region, and that have broad distributions (not restricted to a particular island), and may also explain the “invasion” of *Ceratinidia* from the Oriental region to the Australasian region, i.e., *C. papuana*. The Philippine Islands also harbor many endemic *Ceratinidia* species: *C. tropica*, *C. bicuneata*, *C. compacta*, and some *Xanthoceratina* and *Lioceratina* species. The islands are of oceanic origin, not continental, so are isolated historically from other nearby neighbors. It is not a surprise to find many *Ceratinidia* species endemic to these islands, and not found anywhere else.

Species of *Ceratinidia* tend to be endemic or have distributions restricted to one area as the examples above show in compacta species-group and in species from the Philippine Islands. This notion can be applied to most of the species; for example, all Indian *Ceratinidia* species are found only in India; eastern Chinese and Taiwanese species are restricted to their local areas. In ceratinine bees, the lack of large-scale dispersion is not constrained only to the species-level, but is also known at

the subgeneric-level. No ceratinine subgenus occurs naturally in both eastern and western hemispheres. In the eastern hemisphere, eight subgenera are restricted to the Oriental region, only the subgenus *Pithitis* ranges beyond Asia to Africa (Terzo, 2000).

The topology of *Ceratinidia* species phylogeny recognized in the present study is relatively incongruent with the distribution patterns of the species, except for several groups (*tropica*, *flavipes*, and *compacta* species-groups). Thus, the recent distribution pattern of *Ceratinidia* species might not only be explained through the speciation events, but also in terms of area localization with small-scale dispersion. Although the causes or methods of dispersal for ceratinine bees do not depend on a particular plant or family of plants (Terzo, 2000), the climatic conditions clearly influence the distribution of species.

Consequently, it is probable that historical factors, tied to the phenomena of vicariance, glacial or interglacial isolation, fluctuations in sea level and appearances of isthmuses or, inversely, fragmentation of the land (Wegener, 1915; Croizat, 1952) are principally responsible for the distributions of *Ceratinidia* species and explain the distribution of the subgenus and the species-groups. The phenomenon of dispersal (Darlington, 1957) therefore seems to play a secondary role in their distribution.

Noteworthy features of the distribution of *Ceratinidia* are the areas where further dispersal seems likely, yet has not occurred. If *Ceratinidia* can adapt to Afghanistan, then why has it not dispersed farther in the arid or semiarid countries to the west? If a subgenus most abundant in the moist, tropical, largely forested

countries of Southeast Asia has dispersed to Western New Guinea, why has it not dispersed across the rest of that great island and to nearly moist tropical land masses? Failure to disperse when no climatic, physical, or biotic barrier seems to limit dispersal suggests a group currently in the process of occupying its suitable potential environment, hence a group of no great antiquity.

CHAPTER 4 CONCLUSION

From the time of the first description of a species of *Ceratinidia*, *Ceratina hieroglyphica*, in 1854 by Frederick Smith to the first major revision (1952) of the group by Jacobus van der Vecht, new *Ceratinidia* species were described every now and then by bee specialists around the world, e.g., Makoto Shiokawa and Donald Baker. The present work is an attempt to gather as much information as possible relating to *Ceratinidia* systematics and to assess the number of known species, their geographical distributions, phylogenetic relationships, and to provide identification keys.

A total of approximately 3,100 *Ceratinidia* specimens (from 17 institutions) were examined. Thirty-seven *Ceratinidia* species are recognized (twenty-two by van der Vecht, 1952), with three described as new. The three new species are *C. Chiangmaiensis* (only known from Chiang Mai Province of Thailand), *C. Malukuensis* (known from Batjan and Obi Islands in the Northern Maluku (Moluccas) Islands, Indonesia), and *C. rugosochlypeata* (known from the Nilgiri Hills of South India). All *Ceratinidia* species are fully described for both females and males (if applicable), except for *C. incertula* and *C. maai*. Holotypes or paratypes of almost every name are examined. Lectotypes are designated for names that did not have full type designations. A lectotype of *C. hieroglyphica* Smith from Hong Kong, designated by van der Vecht (1952), represents the type species of *Ceratinidia*, despite a challenge by Baker (2002a) to suppress the lectotype.

A phylogenetic analysis of *Ceratinidia* was performed using exclusively external morphological and color characters. A data set that excludes the correlated

characters was used to create the most robust tree. The phylogeny of *Ceratinidia* species reveals that the two formerly recognized subgenera, *Xanthoceratina* and *Lioceratina*, are within *Ceratinidia*. Five species-groups of *Ceratinidia* are recognized, *bryanti*, *flavipes*, *tropica*, *accusator*, and *compacta* species-groups; for the purpose of easy identification.

The geographical distribution of the subgenus, although centered in the Southeast Asia and nearby islands, extends far west to Afghanistan, far north to the Primorskyi Province of Siberia, and far east to western New Guinea. The broad geographical distribution of *Ceratinidia* species suggests that the group is well adapted to diverse climatic conditions. In addition, the absence of *Ceratinidia* species in the areas such as west of Afghanistan and east of western New Guinea can be interpreted as evidence that the subgenus is a relatively recent group with a potential to extend into other suitable areas yet unoccupied.

Future direction of *Ceratinidia* research will involve (1) a revision of *Xanthoceratina* and *Lioceratina*, and reclassification of *Ceratinidia* that includes species from the two groups, (2) a molecular systematics study of *Ceratinidia*, (3) nesting and social behavioral studies of tropical *Ceratinidia* species, and (4) a study of the systematics of the parasitic mite genus *Sennertia*, commonly found on the bodies of *Ceratinidia*.

LITERATURE CITED

- Alfken, J. D. 1926. Fuana Buruana Apidae, extrait de Treubia VII (3): 259–275.
Archipel Drukkerij, Buitenzorg.
- Ashmead, W. H. 1904. A list of the Hymenoptera of the Philippine Islands, with descriptions of new species. Journal of the New York Entomological Society 12(1): 1–21.
- Baker, D. B. 2002a. On the identity of *Ceratina hieroglyphica* Smith (Insecta: Hymenoptera: Apoidea: Anthophoridae). Reichenbachia, Staatliches Museum Tierkunden Dresden 34 (44): 357–373.
- Baker, D. B. 2002b. On Sulawesi *Ceratina* (*Ceratinidia*) (Hymenoptera, Apoidea, Anthophoridae). Beiträge zur Entomologie 52 (2): 337–345.
- Batra, S. W. T. 1979. *Osmia cornifrons* and *Pithitis smaragdula*, two Asian bees introduced into the United States for crop pollination. Proceeding of the IVth International Symposium on Pollination. Maryland Agricultural Experiment Station Special Miscellaneous Publications. 1: 307–312.
- Bingham, C. T. 1897. Hymenoptera, Vol. I. Wasps and Bees. In W. T. Blanford (ed.). The fauna of British India including Ceylon and Burma. London; Taylor and Francis, xxix + 577 pp.
- Bingham, C. T. 1898. On some new species of Indian Hymenoptera. Journal, Bombay Natural History Society XII: 115–130.

- Cameron, P. 1897. Hymenoptera Orientalis, or contributions to a knowledge of the Hymenoptera of the Oriental zoological region, Part V. *Memoirs, Manchester Literacy and Philosophical Society* 41 (2): 1–144.
- Cockerell, T. D. A. 1910. Descriptions and records of bees.—XXVIII. *Annals and Magazine of Natural History* (8) 5: 409–419.
- Cockerell, T. D.A. 1911. Bees in the collection of the U. S. National Museum. 1. *Proceedings of the United States National Museum* 39: 635–658.
- Cockerell, T. D. A. 1915. Bees from the Philippine Islands. *Entomologist* 48: 107–110.
- Cockerell, T. D. A. 1916. The ceratinid bees of the Philippine Islands. *The Philippine Journal of Science* 11: 301–309.
- Cockerell, T. D. A. 1918. The megachilid bees of the Philippine Islands. *The Philippine Journal of Science* 13: 127–144.
- Cockerell, T. D. A. 1919a. Bees in the collection of the United States National Museum—4. *Proceedings of the United States National Museum* 55: 167–221.
- Cockerell, T. D. A. 1919b. Descriptions and records of bees.—LXXXV. *Annals and Magazine of Natural History* (10) 3: 240–250.
- Cockerell, T. D. A. 1920a. Some bees from Panay. *The Philippine Journal of Science* 16: 145–149.
- Cockerell, T. D. A. 1920b. Supplementary notes of Philippine bees. *The Philippine Journal of Science* 16: 205–207.

- Cockerell, T. D. A. 1920c. Malayan bees. *The Philippine Journal of Science* 17: 615–625.
- Cockerell, T. D. A. 1920d. Some bees from Sandakan, Borneo. *The Philippine Journal of Science* 17: 221–229.
- Cockerell, T. D. A. 1925a. Some Philippine bees. *The Philippine Journal of Science* 26: 54.
- Cockerell, T. D. A. 1925b. Bees from Samar, Philippine Islands. *The Philippine Journal of Science* 27: 169–175.
- Cockerell, T. D. A. 1929. Descriptions and records of bees.—CXVIII. *Annals and Magazine of Natural History* (10) 4: 142–152.
- Cockerell, T. D. A. 1937. Bees of the genera *Halictus* and *Ceratina* from Siam. *American Museum Novitates* 950: 1–12.
- Cockerell, T. D. A. and W. Porter. 1899. Contributions from the New Mexico Biological Station—VII. Observations on bees, with descriptions of new genera and species. *Annals and Magazine of Natural History* (7) 4: 403–421.
- Crawford, J. C. 1910. New Hymenoptera from the Philippine islands. *Proceedings of the United States National Museum* 38: 119–133.
- Croizat, L. 1952. *Manual of Phytogeography or an account of plant-dispersal throughout the World*. Dr. W. Junk, den Haag, 587 pp.
- Daly, H. V. 1973. Bees of the genus *Ceratina* in America North of Mexico (Hymenoptera, Apoidea). *University of California Publications in Entomology* 74: 1–113.

- Daly, H. V. 1988. Bees of the new genus *Ctenoceratina* in Africa South of the Sahara (Hymenoptera: Apoidea). University of California Publications in Entomology 108: 1–69.
- Daly, H. V., G. E. Bohart, and R. W. Thorp. 1971. Introduction of small carpenter bees into California for pollination. 1. Release of *Pithitis smaragdula*. Journal of Economic Entomology 64 (5): 1145–1150.
- Darlington, P. J. 1957. Zoogeography: the zoogeographical distribution of animals. Chapman & Hall, Limited, London, 675 pp.
- Eickwort, G. C. 1994. Evolution and life-history patterns of mites associated with bees, pp.218–251. In M. A. Houck (ed.). Mites. Chapman and Hall, New York, xxii + 357 pp.
- Fain, A. 1981. A revision of the phoretic deutonymph (hypopi) of the genus *Sennertia* Oudemans, 1905 (Acari, Astigmata, Chaetodactylidae). Systematics Parasitology 3: 145–183.
- Friese, H. 1914. Die Bienenfauna von Java. Tijdschrift voor Entomologie 57: 1–61.
- Goloboff, P. A. 1993. Noname (NONA), version 2.0. Program and documentation. Tucumán, Argentina: Fundación e Instituto Miguel Lillo.
- Hedicke, H. 1926. Beiträge zur Apidenfauna der Philippinen (Hym.). Deutsch Entomologische Zeitschrift 1926: 413–424.
- Hirashima, Y. 1958. Bees of the Amani Islands. I. (Hymenoptera, Apoidea). Mushi 32:69–76.

- Hirashima, Y. 1965. Bees (excluding Halictidae) of the Ryukyu Islands taken in the 1963 and 1964 surveys (Hymenoptera, Apoidea). *Kontyû* 33: 247–259.
- Hirashima, Y. 1971. Subgeneric classification of the genus *Ceratina* Latreille of Asia and west Pacific, with comments on the remaining subgenera of the world (Hymenoptera, Apoidea). *Journal of the Faculty of Agriculture, Kyushu University* 16: 349–375.
- Kim, M. R. 1999. Analysis of individual variation types in *Ceratina japonica* (Anthophoridae: Apoidea). *Entomological Research Bulletin (KEI)* 25:7–11.
- Kurosa, K. 2003. A new subgenus and species of *Sennertia* (Acari, Chaetodactylidae) associated with small carpenter bees, *Ceratina* spp. (Hymenopter, Apidae) in Japan. *Journal of the Acarological Society of Japan* 12 (1): 25–31.
- Latreille, P. A. 1802a. *Histoire Naturelle des Fourmis*.... Paris: Crapelet, xvi + 445 pp., 12 pls.
- Latreille, P. A. 1802b. *Histoire Naturelle Générale et Particulière des Crustacés et des Insectes*, Vol.3. Paris, xii + 467 pp.
- Lee, S., H. Kim, and W. Lee. 2005. A review of the small carpenter bees, *Ceratina*, from Korea, with the description of new species (Hymenoptera: Apidae). *Entomological News* 116 (3): 137–146.
- Lombert, H. A. P. M., B. M. Oconnor, F. S. Lukoschus, and J. O. Whitaker, Jr. 1987. Ontogeny, systematics and ecology of *Sennertia (Amsennennertia) Americana* Delfinado and Baker, 1976 (Acari: Chaetodactylidae) from the nest of the

- carpenter bee, *Xylocopa virginica* (Hymenoptera: Anthophoridae).
International Journal of Acarology 13: 113–129.
- Maeta, Y. 1993. Social life of *Ceratina iwatai* (Hymenoptera, Xylocopinae), pp. 147–206. In T. Inoue and S. Yamane (eds.). Evolution of Insect Societies. Tokyo: Hakuhunsha, vii + 532 pp. (in Japanese)
- Maeta, Y., and S. F. Sakagami. 1995. Oophagy and egg replacement in artificially induced colonies of basically solitary bee, *Ceratina (Ceratinidia) okinawana* (Hymenoptera, Anthophoridae, Xylocopinae), with a comparison of social behaviour among *Ceratina*, *Xylocopa* and the halictine bees. Japan Journal of Entomology 63: 347–375.
- Matsumura, S. and T. Uchida. 1926. Die Hymenopteren-Fauna von den Riukiu-Inseln. Insecta. Matsumurana 1(2): 63–77.
- Mayr, E. and P. D. Ashlock. 1991. Principle of systematic Zoology, Second Edition. McGraw-Hill, New York, xx + 475 pp.
- Mayr, E., E. G. Linsley, and R. L. Usinger. 1953. Methods and principles of systematic zoology. McGraw-Hill Book Company, Inc., New York, 328 pp.
- Michener, C. D. 1944. Comparative external morphology, phylogeny, and a classification of the bees. Bulletin of the American Museum of Natural History 82: 151–326.
- Michener, C. D. 1974. The social behavior of the bees. Harvard University Press, Cambridge, Massachusetts, xii + 404 pp.

- Michener, C. D. 1990. Castes in Xylocopine bees, pp. 124–146. *In* W. Engels (ed.). *Social Insects, an Evolutionary Approach to Castes and Reproduction*. Springer Verlag, Berlin, iv + 265 pp.
- Michener, C. D. 1997. Genus-group names of bees and supplemental family group names. *Scientific Paper, Natural History Museum, University of Kansas* 1: 1–81.
- Michener, C. D. 2000. *The bees of the world*. The John Hopkins University Press, Baltimore and London, xiv + 913 pp.
- Morawitz, F. F. 1890. *Insecta a Cl. G.N. Potanin in China et in Mongolia novissime lecta*. XIV. Hymenoptera Aculeata. II. *Horae Societatis Entomologicae Rossicae* 24: 349–385.
- Nixon, K. C. 2002. WinClada ver. 1.00.08. Program and documentation, Ithaca, New York: Cornell University.
- O'Connor, B.M. 1988. Coevolution in astigmatid mite-bee associations, pp. 339–346. *In* G. R. Needham, R. E. Page, Jr., M. Delfinado-Baker, and C. Bowman (eds.). *Africanized Honey Bees and Bee Mites*. Ellis-Horwood, Ltd. Chichester, England.
- Platnick, N. I. 1977. Cladograms, phylogenetic trees, and hypothesis testing. *Systematic Zoology* 26: 438–442.
- Roig-Alsina, A. and C. D. Michener. 1993. Studies of the phylogeny and classification of long-tongued bees. *University of Kansas Science Bulletin* 55: 124–162.

- Sakagami, S. F., K. Tanno, and O. Enomoto. 1981. Cold resistance of the small carpenter bee *Ceratina flavipes* restudied. Low Temperature Sciences Series B 39: 1–7.
- Sakagami, S. F. and Y. Maeta. 1977. Some presumably presocial habits of the Japanese *Ceratina* bees, with notes on various social types in Hymenoptera. Insectes Sociaux 24: 319–343.
- Sakagami, S. F. and Y. Maeta. 1984. Multifemale nests and rudimentary castes in the normally solitary bee *Ceratina japonica* (Hymenoptera: Xylocopinae). Journal of the Kansas Entomological Society 57: 639–656.
- Sakagami, S. F. and Y. Maeta. 1985. Multifemale nests and rudimentary castes in the normally solitary bee *Ceratina japonica* (Hymenoptera: Xylocopinae). Journal of the Kansas Entomological Society 57: 639–654.
- Sakagami, S. F. and Y. Maeta. 1987a. Multifemale nests and rudimentary castes of an “almost” solitary bee *Ceratina flavipes*, with additional observations on multiple nests of *Ceratina japonica* (Hymenoptera: Apoidea). Kontyû 55: 391–409.
- Sakagami, S. F. and Y. Maeta. 1987b. Sociality, induced and/or natural in the basically solitary small carpenter bees (*Ceratina*), pp. 1–16. In Y. Ito, J. L. Brown, and J. Kikkawa (eds.). Animal Societies: Theories and Facts. Japanese Science Societies Press, Tokyo, 291 pp.
- Sakagami, S. F. and Y. Maeta. 1989. Compatibility and in compatibility of solitary life with eusociality in two normally solitary bees *Ceratina japonica* and

- Ceratina okinawana* (Hymenoptera, Apoidea), with notes on the incipient phase of eusociality. *Japanese Journal of Entomology* 57: 417–439.
- Sakagami, S. F. and Y. Maeta. 1995. Task allocation in artificially induced colonies of a basically solitary bee *Ceratina* (*Ceratinidia*) *okinawana*, with a comparison of sociality between *Ceratina* and *Xylocopa* (Hymenoptera, Anthophoridae, Xylocopinae). *Japan Journal of Ecology* 63: 115–150.
- Shiokawa, M. 1963. Redescriptions of *Ceratina flavipes* Smith and *C. japonica* Cockerell. *Kontyû* 31: 276–280.
- Shiokawa, M. 1999. Two new subspecies of a small carpenter bee, *Ceratina okinawana* from East Asia (Hymenoptera, Anthophoridae). *Japanese Journal of Systematic Entomology* 5(2): 259–266.
- Shiokawa, M. 2002. Taxonomic notes on the *bryanti*-group of the bee genus *Ceratina* from Southeast China (Hymenoptera: Apidae). *Entomological Science* 5(4): 411–419.
- Shiokawa, M. and Y. Hirashima. 1982. Synopsis of the flavipes-group of the bee genus *Ceratina* of Eastern Asia (Hymenopter, Anthophoridae). *Esakia* 19: 177–184.
- Sickman, F. 1894. Beiträge zur Kenntniss der Hymenopteren-Fauna des nördlichen China. *Zoologische Jahrbücher, Abteilung für Systematik, Geographie und Biologie der Thiere* 8: 195-236.

- Skaife, S. H. 1952. The yellow-banded carpenter bee, *Mesotrichia caffra* Linn., and its symbiotic mite, *Dinogamasus braunsi* Vitzthum. *Journal of the Entomological Society of South Africa* 15: 63–76.
- Smith, F. 1854. Catalogue of Hymenopterous Insects in the Collection of the British Museum, Part 2: 199–465, pls. vii–xii. London: British Museum.
- Smith, F. 1879. Descriptions of new species of Hymenoptera in the collection of the British Museum. London; British Museum, 240 pp.
- Snodgrass, R. E. 1935. Principles of insect morphology. Cornell University Press, Ithaca and London, xiv + 667 pp.
- Tattersall, I. and N. Eldredge. 1977. Fact, theory, and fantasy in human paleontology. *American Scientists* 65: 204–211.
- Terzo, M. 1992. Les Cératines d'Europe Occidentale (Hymenoptera, Anthophoridae: *Ceratina* Latreille) Systématique, biogéographie, écologie et zootechnie. Travail de fin d'étude, Université de Mons-Hainaut, 98 + xi pp.
- Terzo, M. 2000. Classification phylogénétique des Cératines du monde et monographie des espèces de la région ouest-paléarctique et de l'Asie Centrale (Hymenoptera, Apoidea, Xylocopinae: *Ceratina* Latreille). Ph.D. Thesis Université de Mons-Hainaut, 4 + 263 + xxiii pp.
- Van der Vecht, J. 1952. A preliminary revision of the Oriental species of the genus *Ceratina* (Hymenoptera, Apidae). *Zoologische Verhandlungen* 16: 1–85.
- Watmough, R. H. 1974. Biology and behaviour of carpenter bees in South Africa. *Journal of the Entomological Society of South Africa* 37: 261–281.

- Warrit, N. 2007. *Ceratina (Ceratinidia) compacta*, a small carpenter bee in Thailand: an apparent recent addition to the fauna (Hymenoptera: Apidae). *Journal of the Kansas Entomological Society* 80: 72–77.
- Wegener, 1915. *Die Entstehung der Kontinente und Ozeane*. Sammlung Vieweg (23), Braunschweig, 94 pp.
- Wikramanayake, E., E. Dinerstein, C. J. Loucks, D. M. Olson, J. Morrison, J. Lamoreux, M. McKnight, P. Hedao. 2002. *Terrestrial Ecoregions of the Indo-Pacific—a conservation assessment*. Island Press, Washington xxix +643 pp.
- Wiley, E. O. 1981. *Phylogenetics: the theory and practice of phylogenetic systematics*. Wiley-Intersciences Publications, xv + 439 pp.
- Wu, Y. –r. 1963. Results of the 1955–1957 zoological-botanical expedition to Southwest China. *Acta entomologica Sinica* 12: 83–92. [In Chinese with Russian summary.]
- Wu, Y. –r. 1988. Hymenoptera: Apoidea, pp. 545–552. *In* F-S Huang (ed.). *Insects of Mt. Namjagbarwa of Xizang*, Sciences Press, Beijing, 621pp.
- Wu, Y. –r. 2002. *Fauna Sinica Insecta*, 20: 154–176, Hymenoptera, Melittidae, Apidae. Science Press, Beijing. [In Chinese.]
- Yasumatsu, K. and Y. Hirashima. 1969. Synopsis of the small carpenter bee genus *Ceratina* of Japan (Hymenoptera, Anthophoridae). *Kontyu* 37: 61–70.

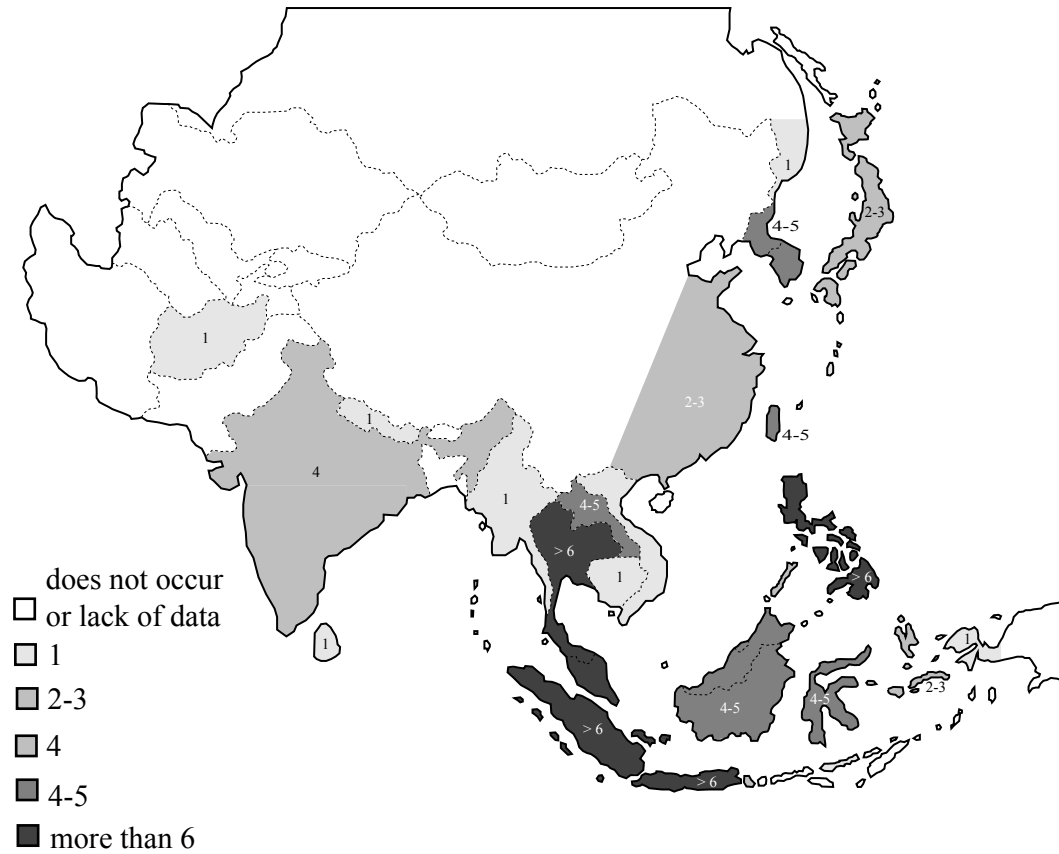
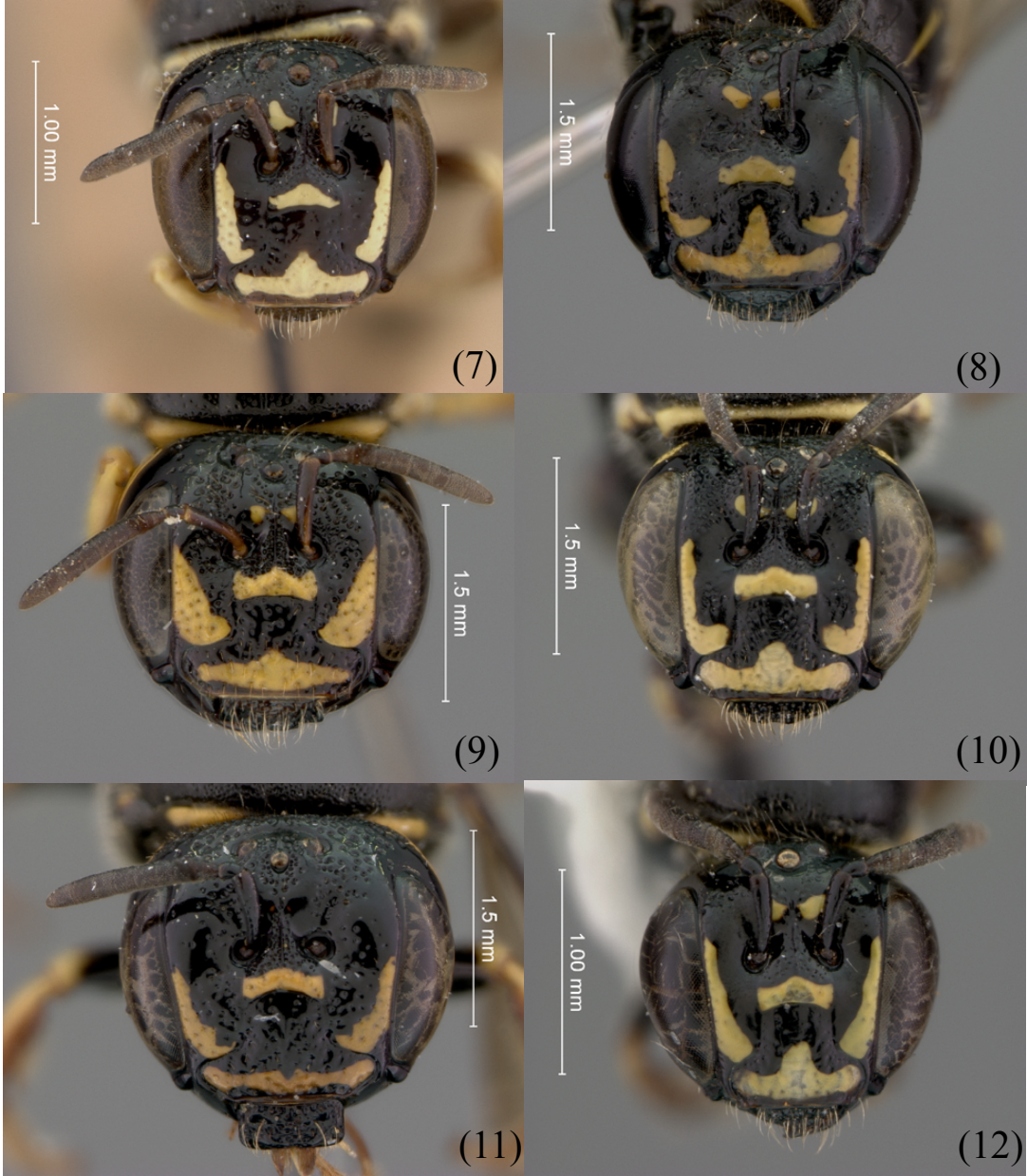
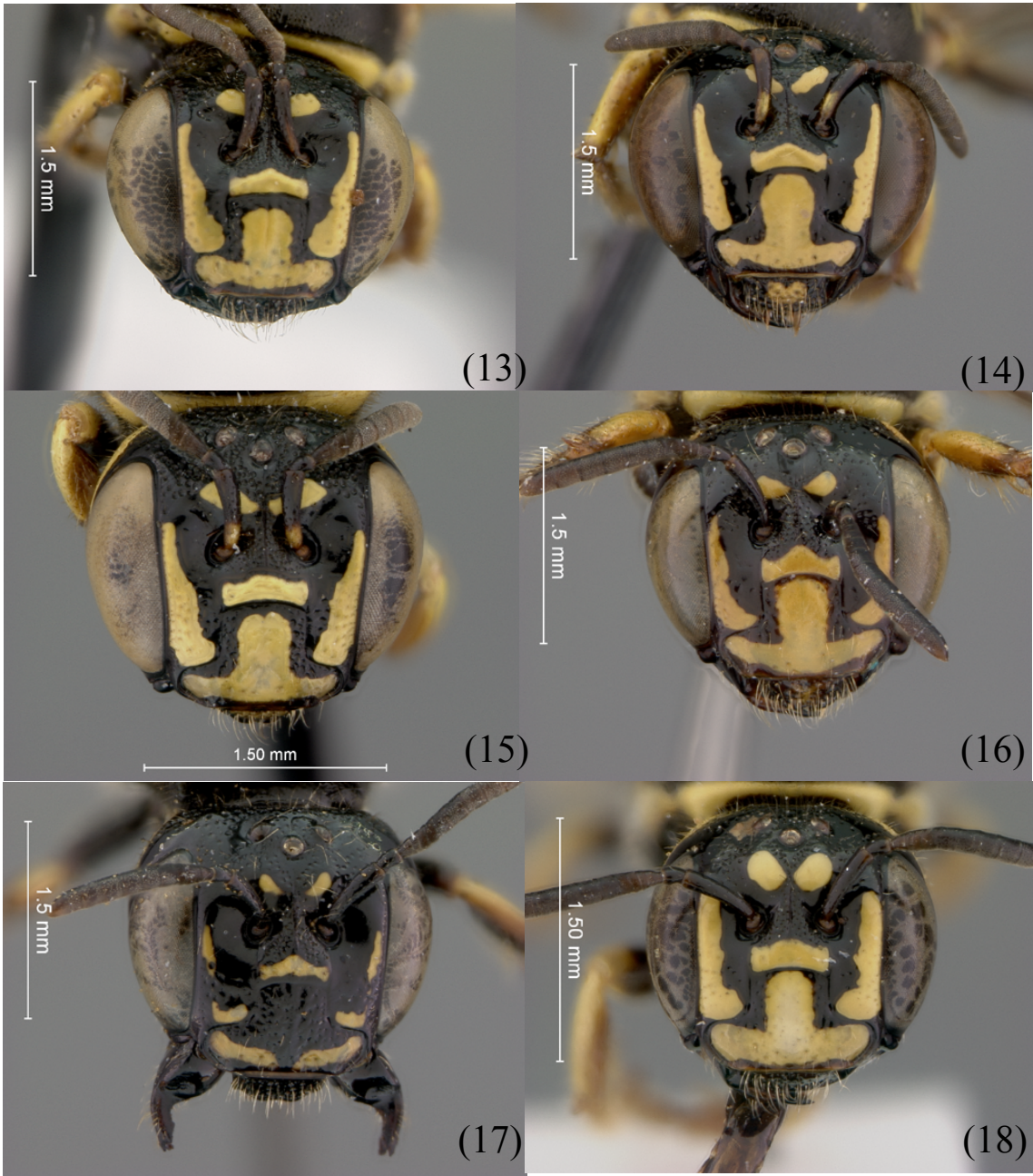

Figure 1 Map of Asia portraying geographical range of *Ceratinidia*, and summarizing number of *Ceratinidia* species inhabit in different countries. The grey sclae indicates in the illustration, ranges from light (1 species) to dark (more than 6 species).



Figures 7-12. Female faces: *Ceratina accusator* (7), *C. alpicola* (8), *C. bicuneata* (9), *C. bryanti* (10), *C. carinifrons* (11), *C. Chiangmaiensis* new species (12)



Figures 13-18. Female faces: *Ceratina cognata* (13), *C. collusor* (14), *C. compacta* (15), *C. demotica* (16), *C. flavipes* (17), *C. hieratica* (18)

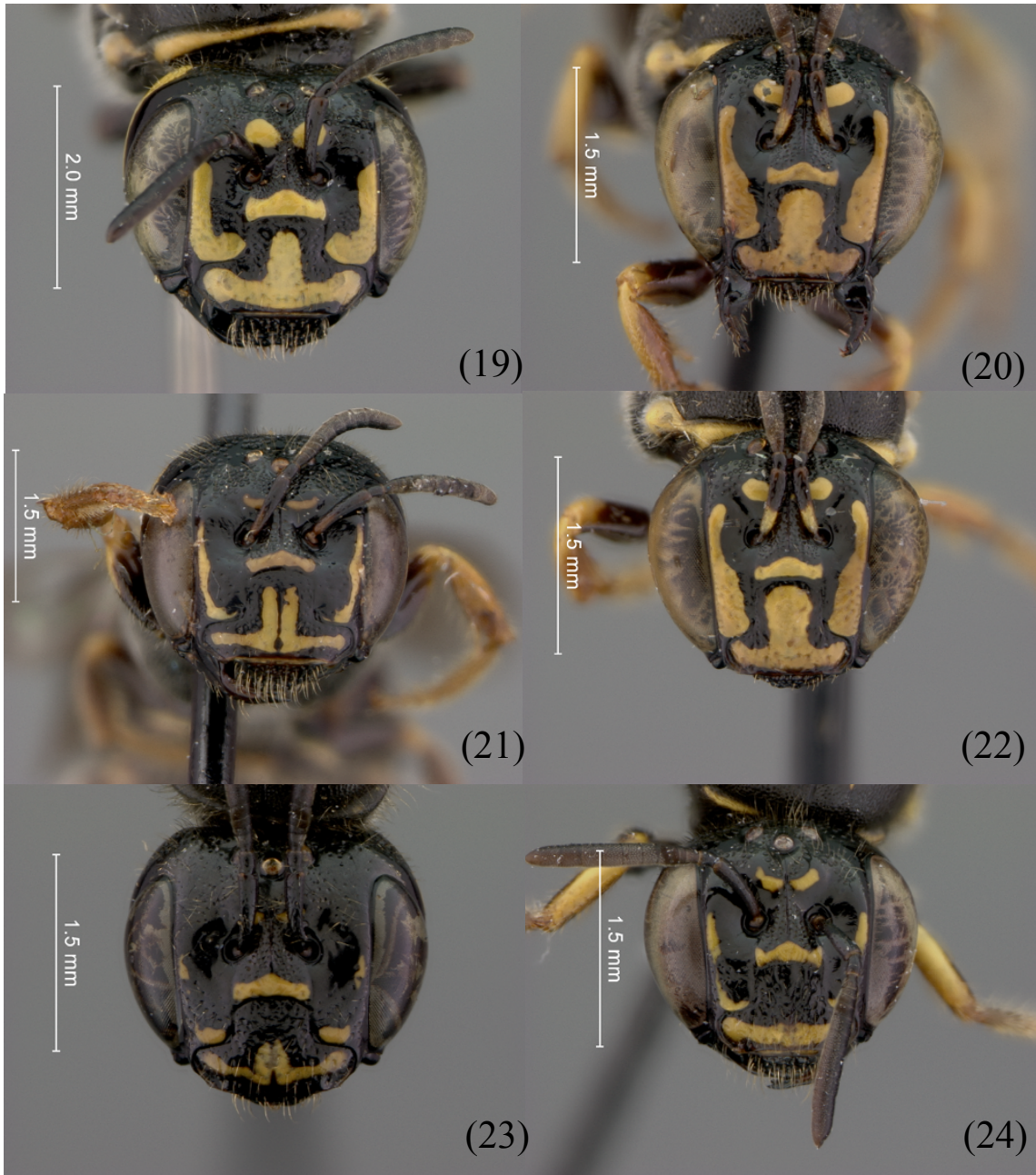

Figures 19-24. Female faces: *Ceratina lepida* (19), *C. incertula* (20), *C. interrupta* (21), *C. jacobsoni* (22), *C. japonica* (23), *C. jejuensis* (24)

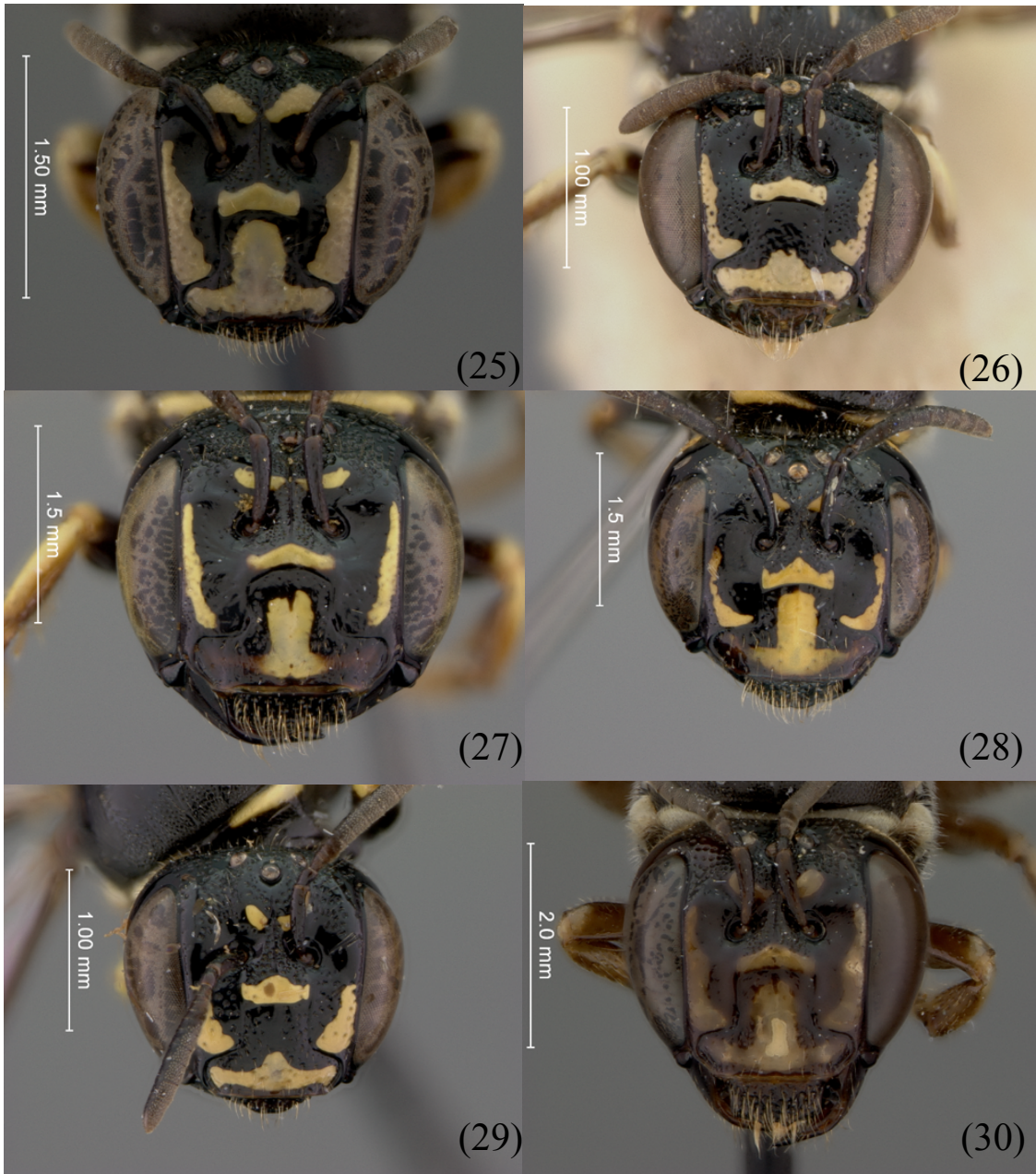

Figures 25-30. Female faces: *Ceratina lieftincki* (25), *C. litoraria* (26), *C. malukuensi* new species (27), *C. moderata* (28), *C. accusator mutabilis* (29), *C. nigrolateralis* (30)

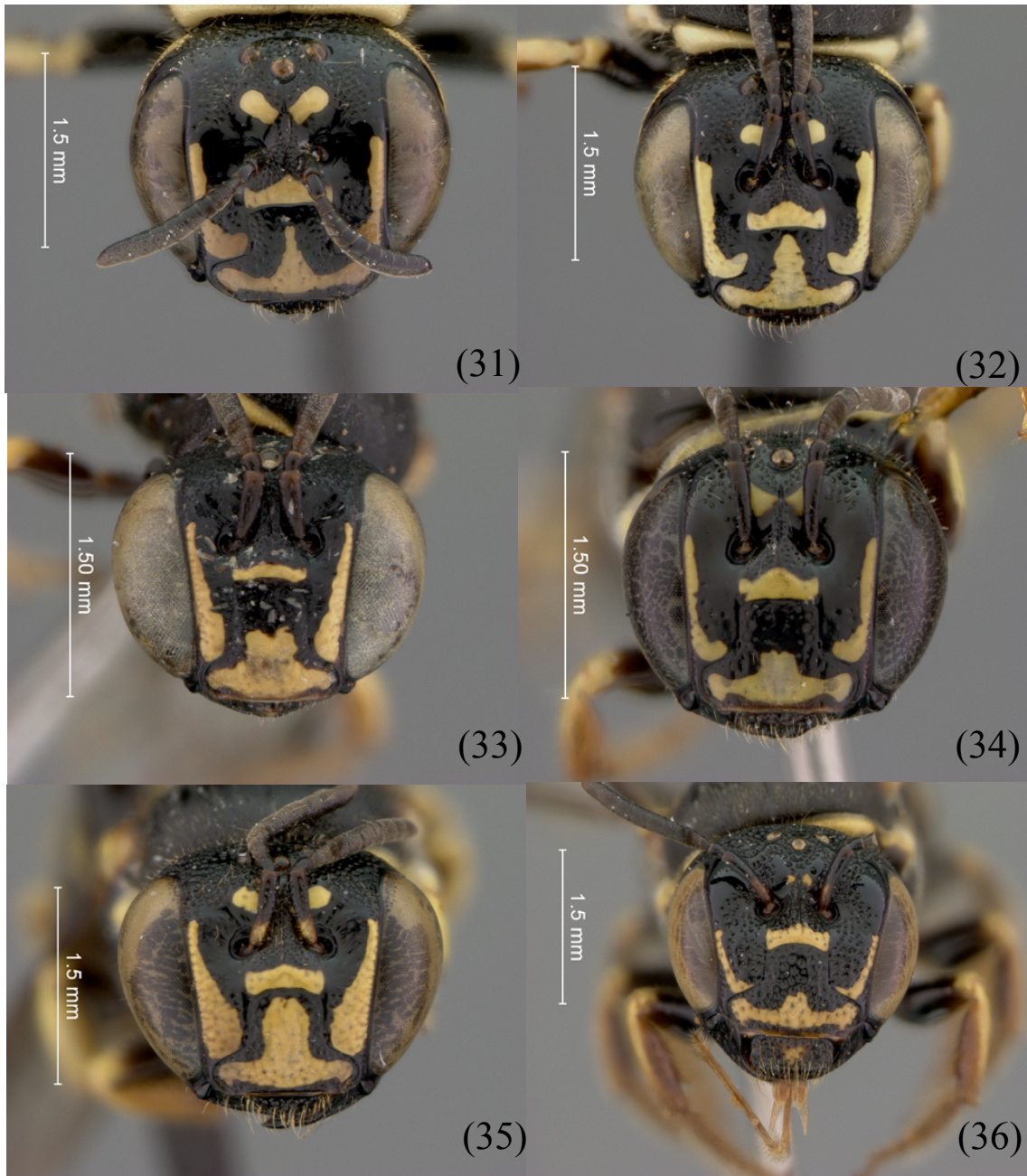

Figures 31-36. Female faces: *Ceratina okinawana okinawana* (31), *C. o. sakishimensis* (32), *C. papuana* (33), *C. pulchripes* (34), *C. punctigena* (35), *C. rugifrons* (36)

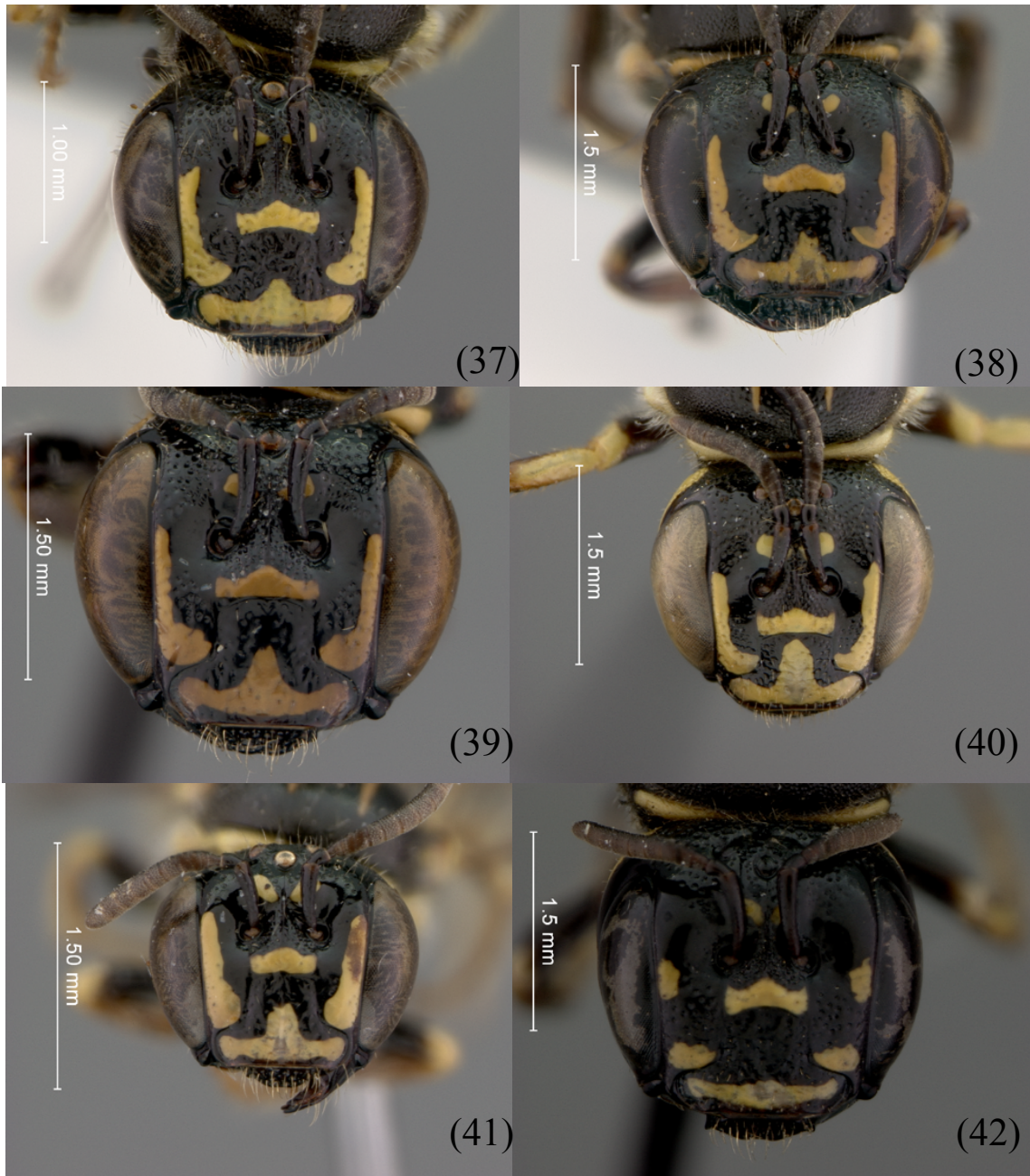

Figures 37-42. Female faces: *Ceratina rugosoclypeata* new species (37), *C. simillima* (38), *C. sutepensis* (39), *C. taiwanensis* (40), *C. takasagona* (41), *C. tropica* (42)

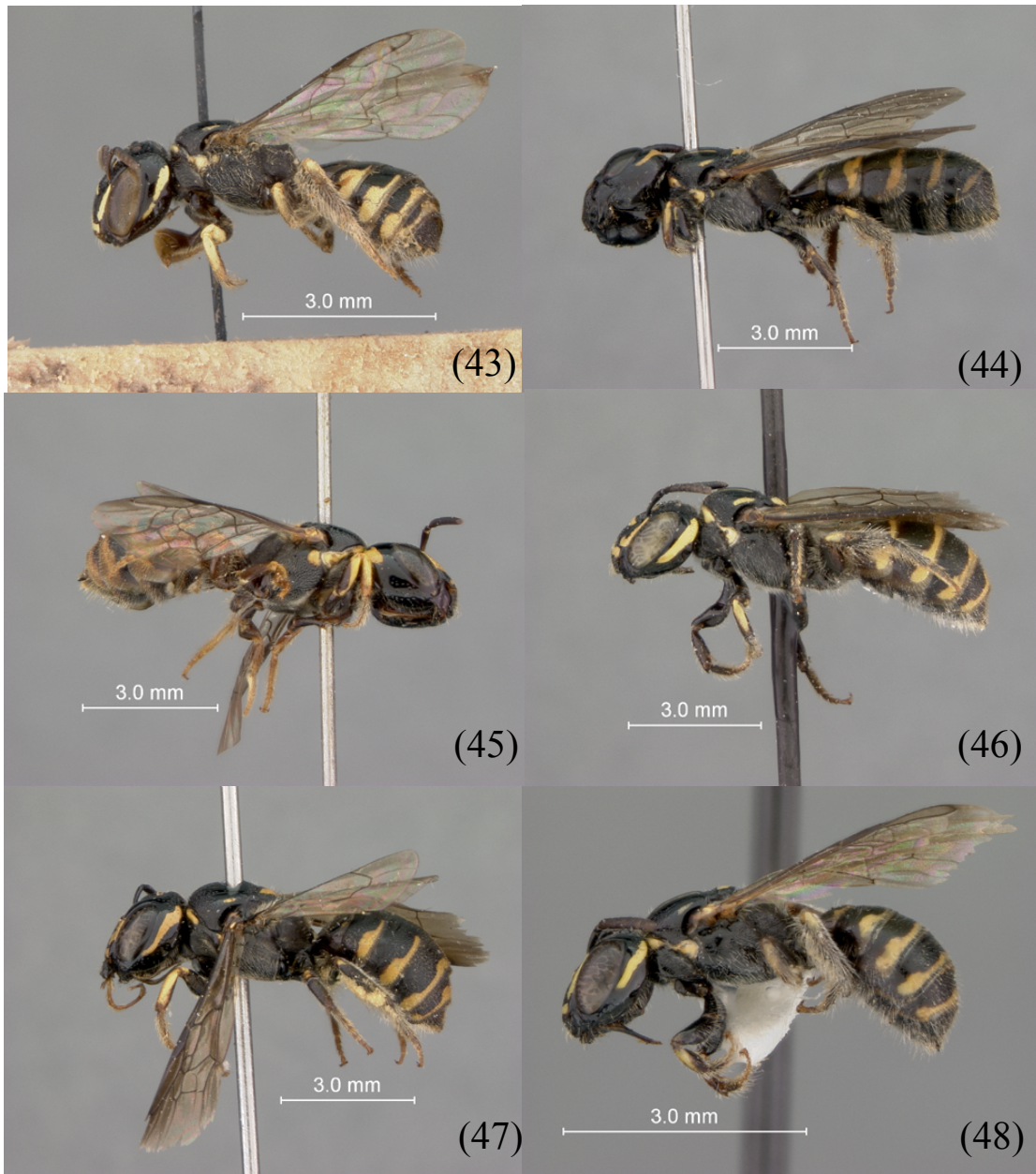

Figures 43-48. Female lateral views: *Ceratina accusator* (43), *C. alpicola* (44), *C. bicuneata* (45), *C. bryanti* (46), *C. carinifrons* (47), *C. Chiangmaiensis* new species (48)

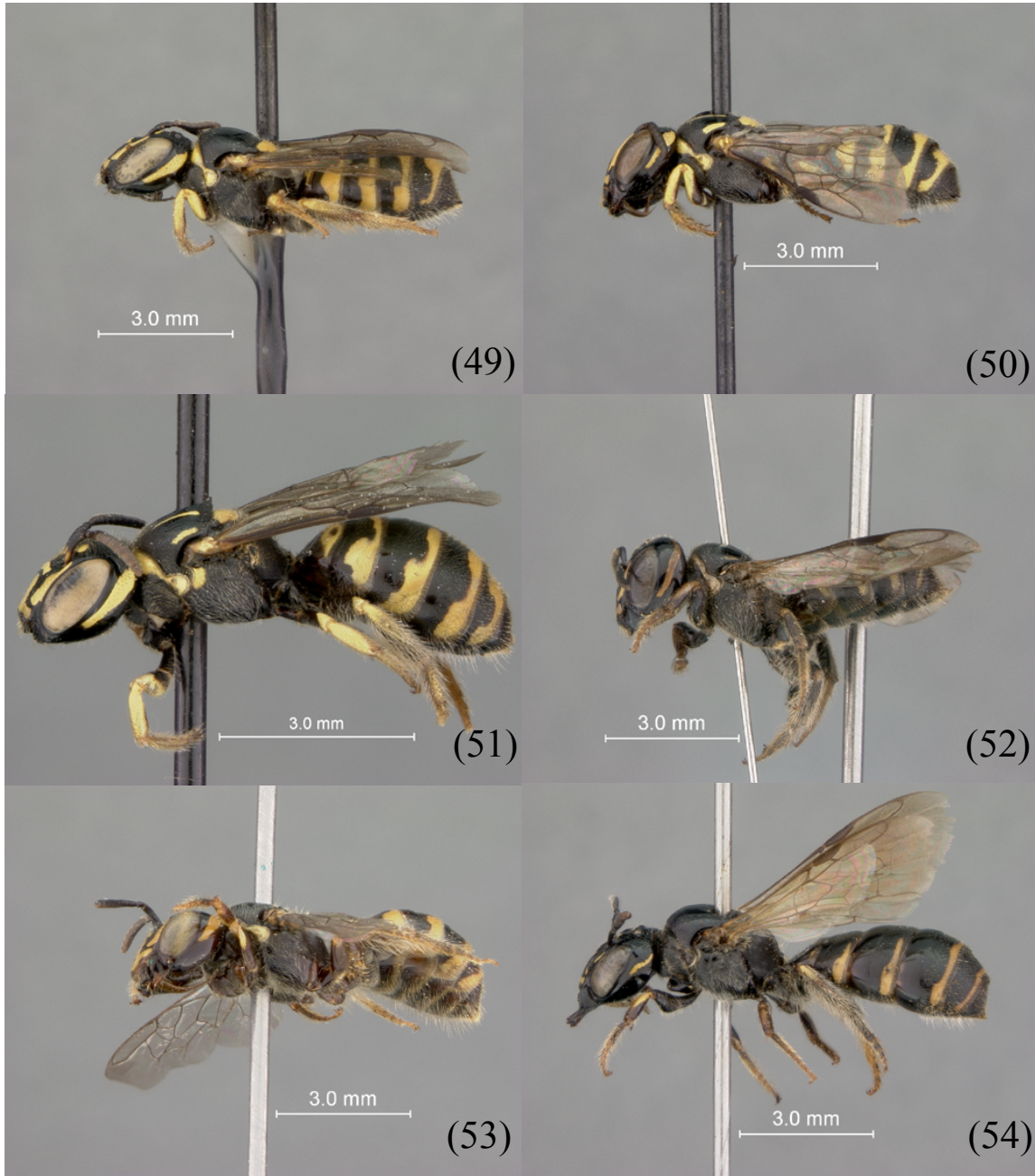
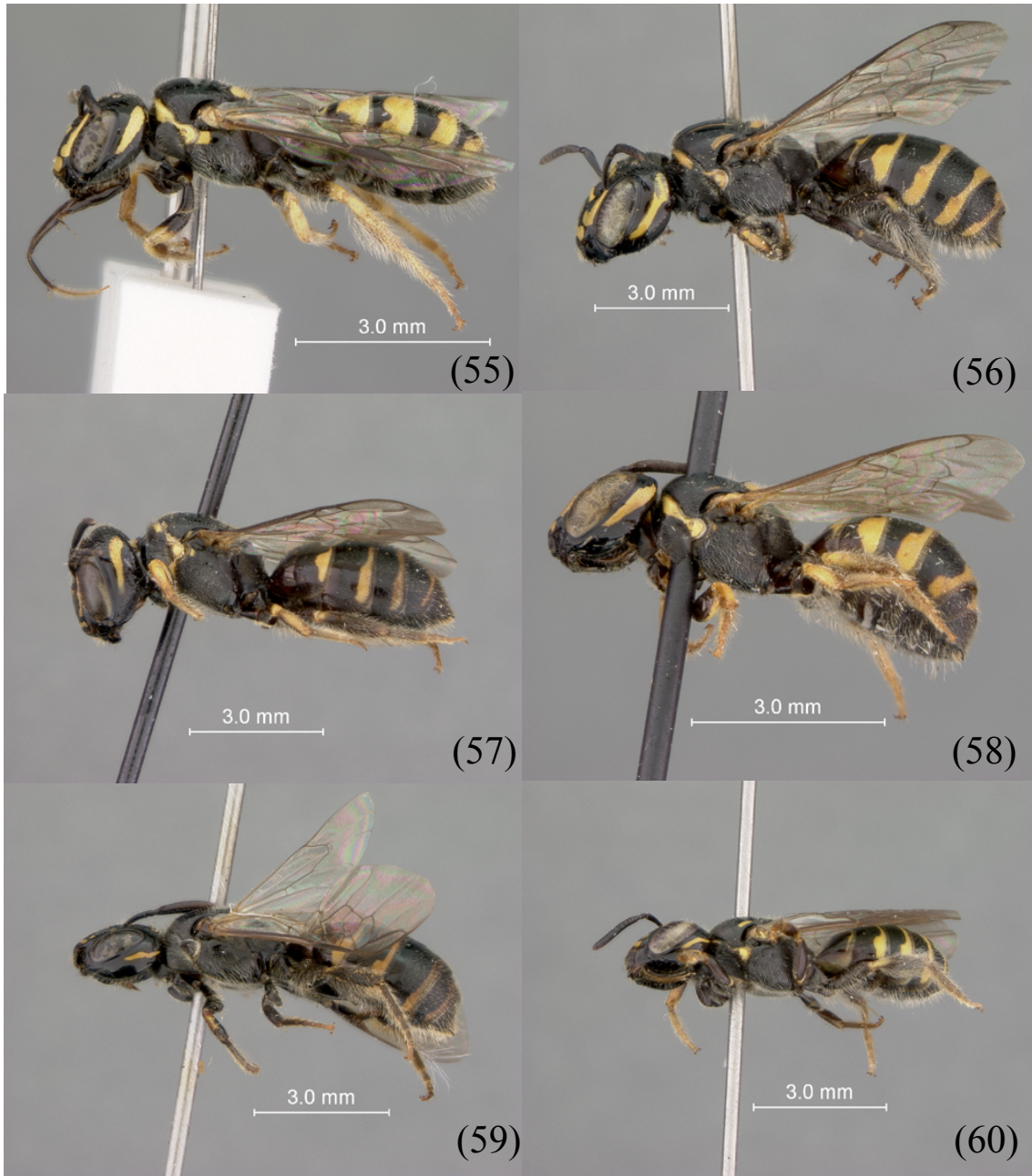
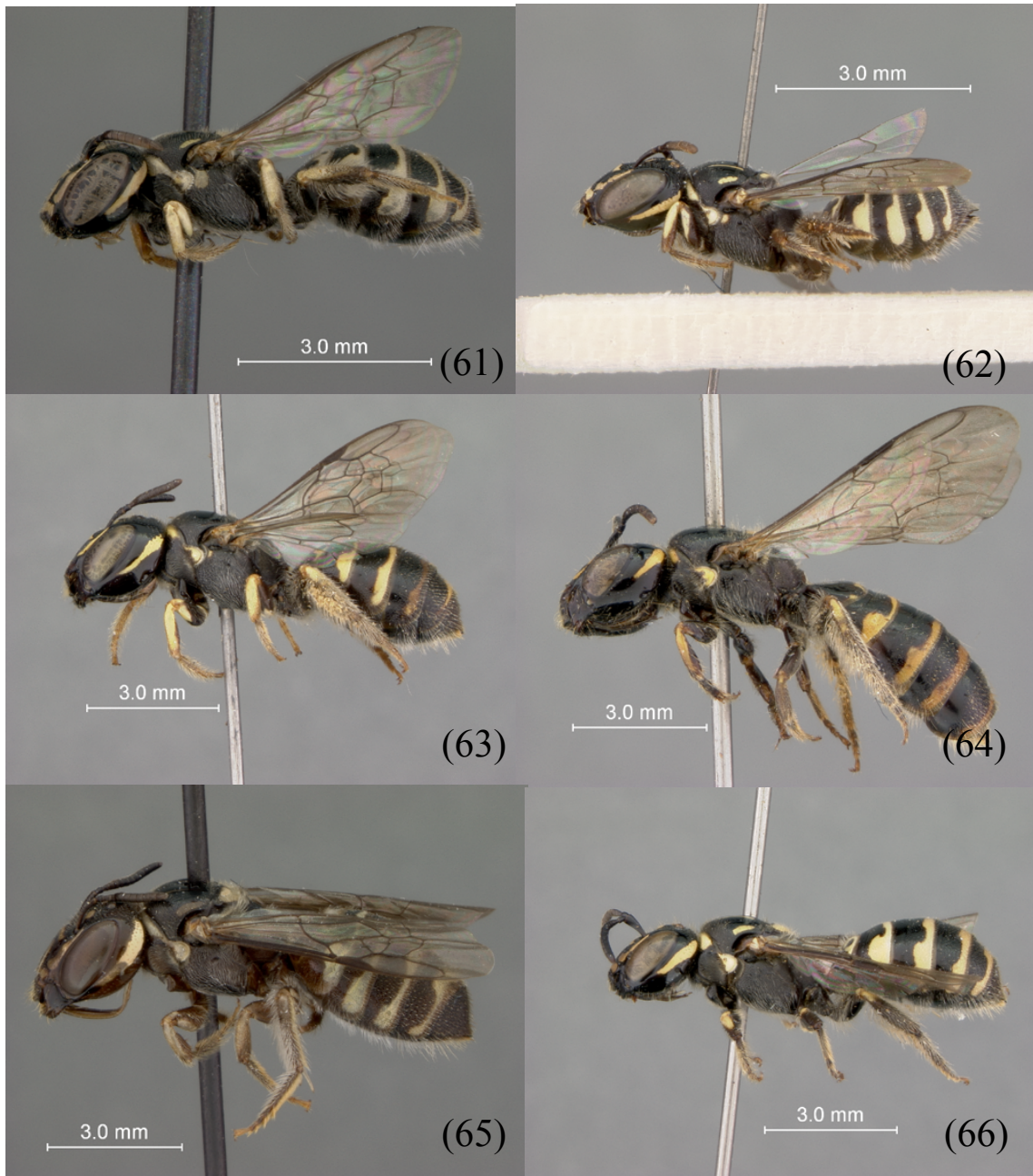

Figure 49-54. Female lateral views: *Ceratina cognata* (49), *C. collusor* (50), *C. compacta* (51), *C. coptica* (52), *C. demotica* (53), *C. flavipes* (54)



Figures 55-60. Female lateral views: *Ceratina hieratica* (55), *C. lepida* (56), *C. interrupta* (57), *C. jacobsoni* (58), *C. japonica* (59), *C. jejuensis* (60)



Figures 61-66. Female lateral views: *Ceratina lieftincki* (61), *C. litoraria* (62), *C. malukuensi* new species (63), *C. moderata* (64), *C. nigrolateralis* (65), *C. okinawana okinawana* (66)

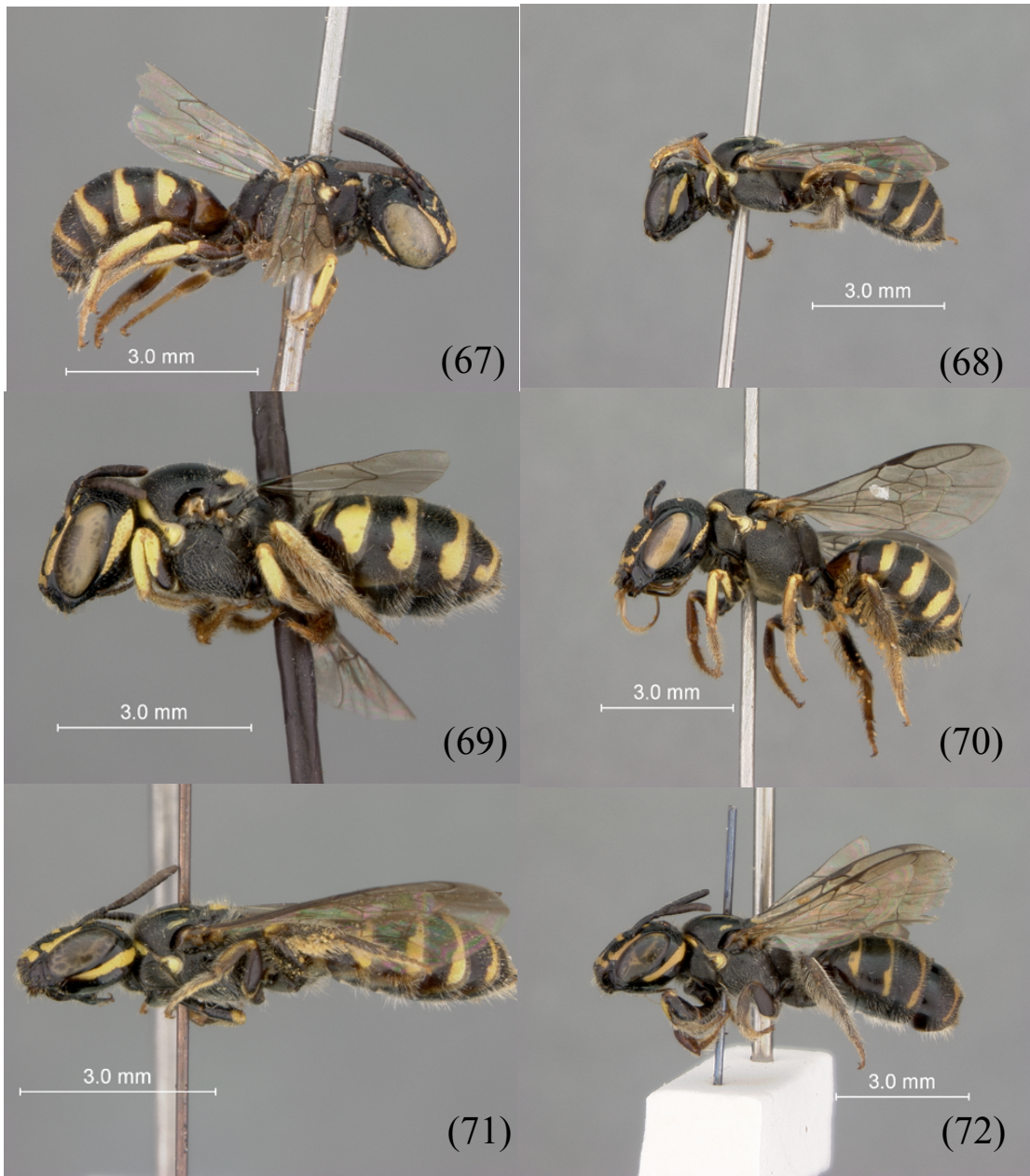

Figures 67-72. Female lateral views: *C. papuana* (67), *C. pulchripes* (68), *C. punctigena* (69), *C. rugifrons* (70), *C. rugosoclypeata* new species (71), *C. simillima* (72)

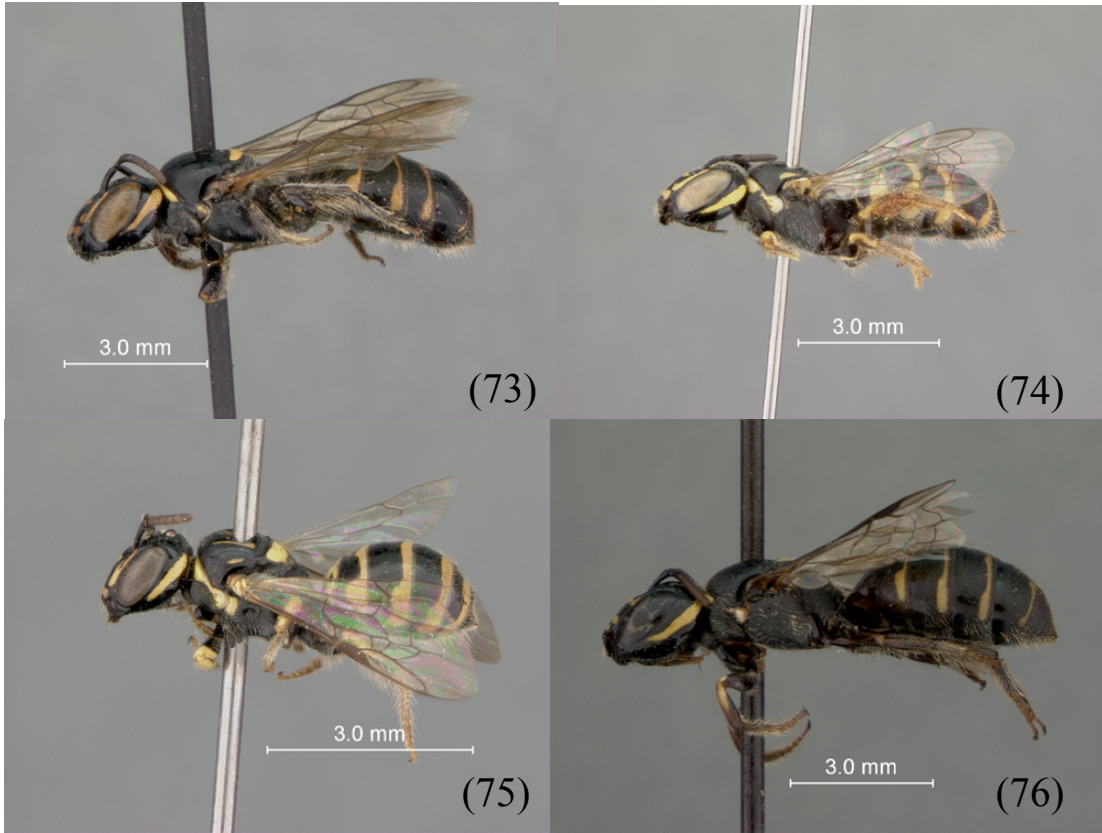

Figures 73-76. Female lateral views: *Ceratina sutepensis* (73), *C. taiwanensis* (74), *C. takasagona* (75), *C. tropica* (76)

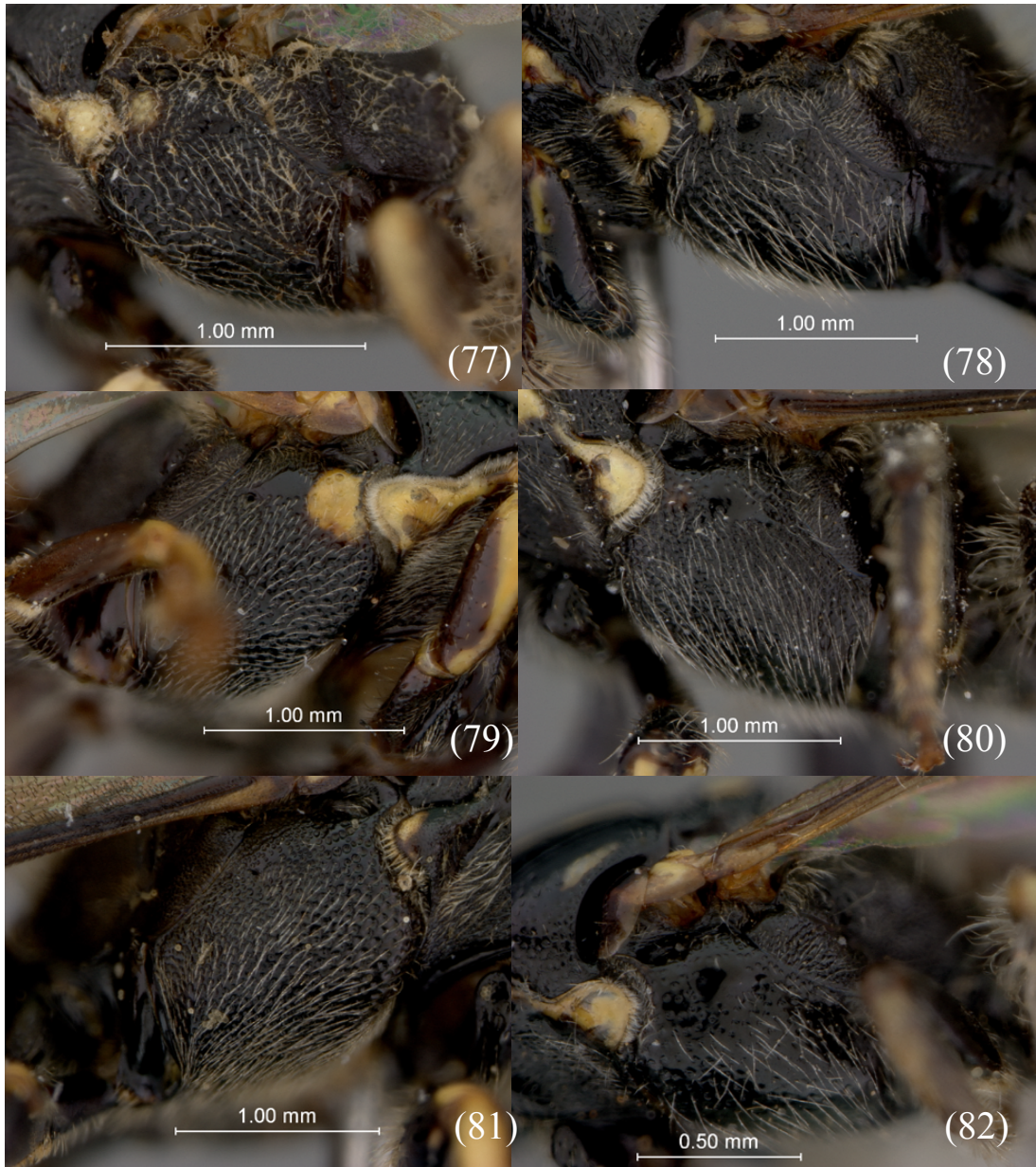

Figures 77-82. Female mesepisternums: *Ceratina accusator* (77), *C. alpicola* (78), *C. bicuneata* (79), *C. bryanti* (80), *C. carinifrons* (81), *C. Chiangmaiensis* new species (82)

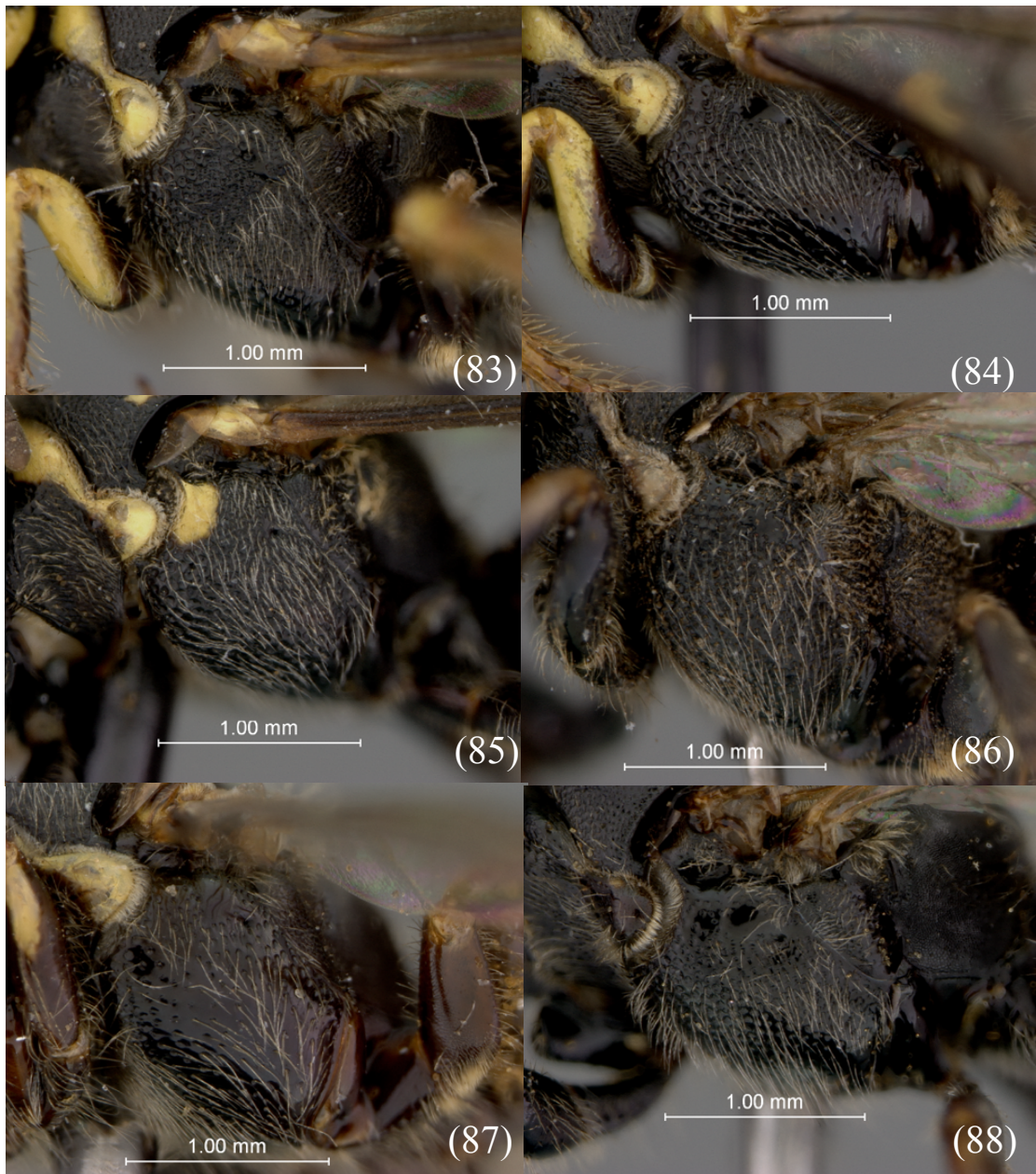

Figures 83-88. Female mesepisternums: *Ceratina cognata* (83), *C. collusor* (84), *C. compacta* (85), *C. coptica* (86), *C. demotica* (87), *C. flavipes* (88)

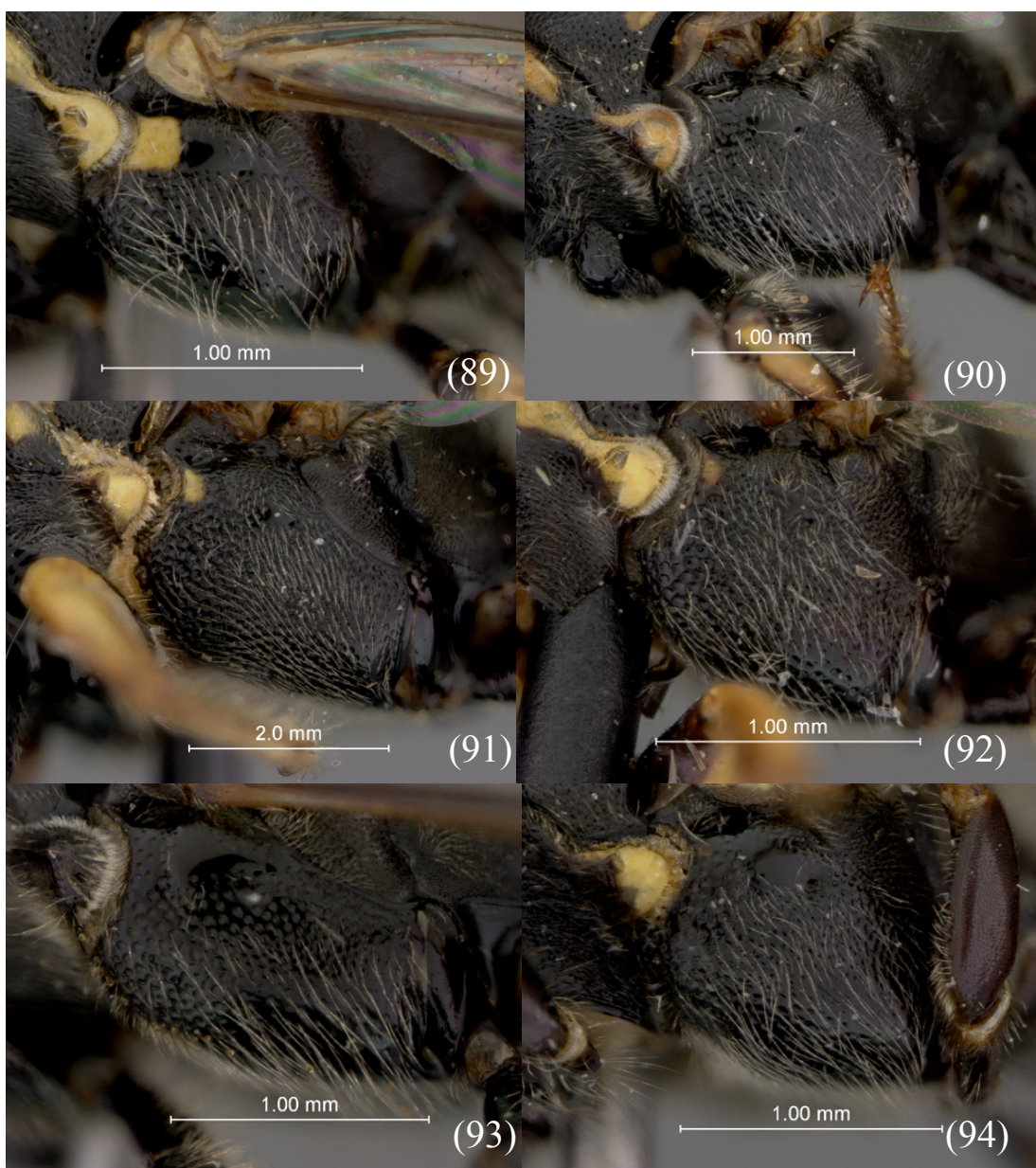

Figures 89-94. Female mesepisternums: *Ceratina hieratica* (89), *C. lepida* (90), *C. interrupta* (91), *C. jacobsoni* (92), *C. japonica* (93), *C. jejuensis* (94)

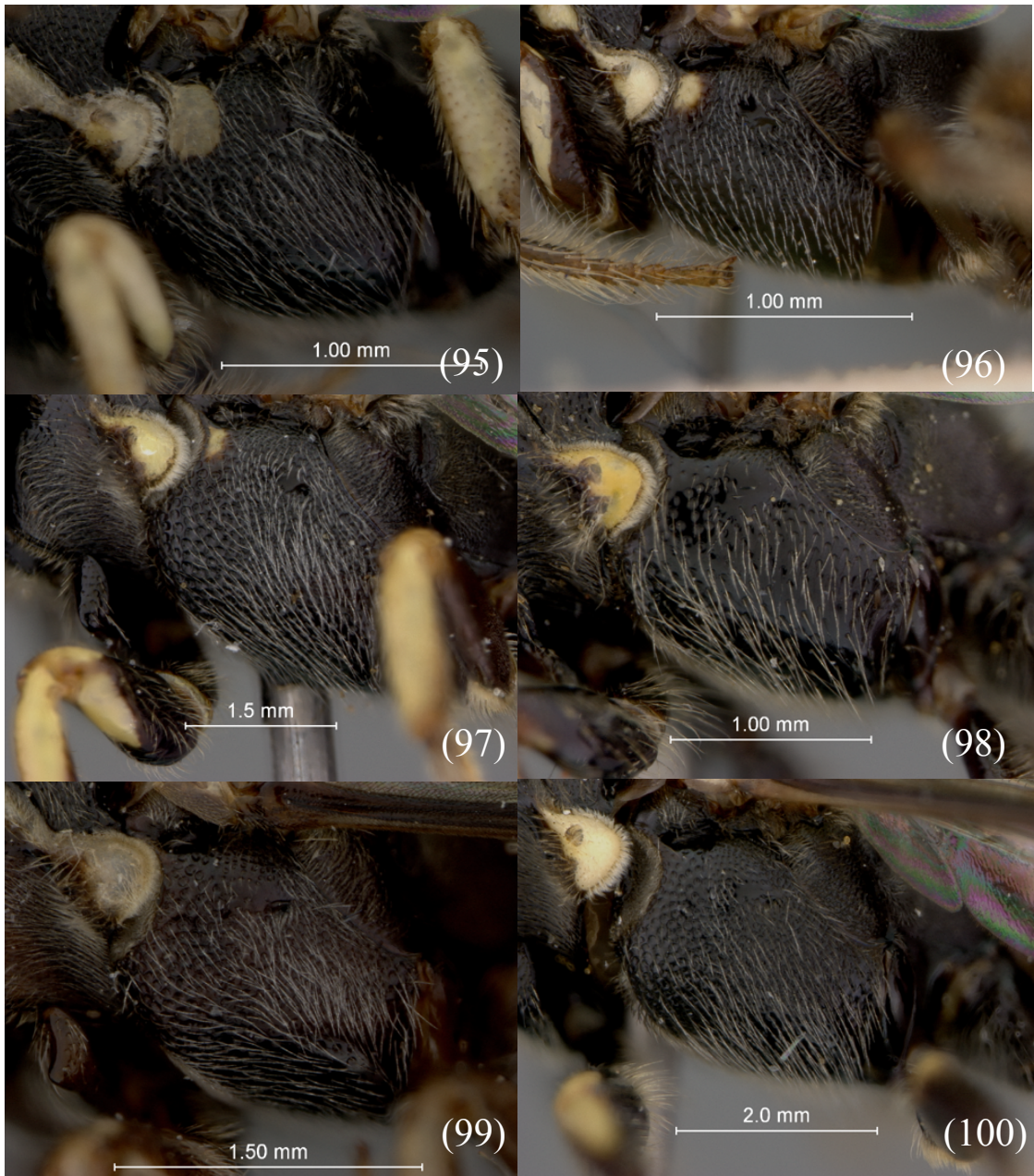

Figures 95-100. Female mesepisternums: *Ceratina lieftincki* (95), *C. litoraria* (96), *C. malukuensi* new species (97), *C. moderata* (98), *C. nigrolateralis* (99), *C. okinawana okinawana* (100)

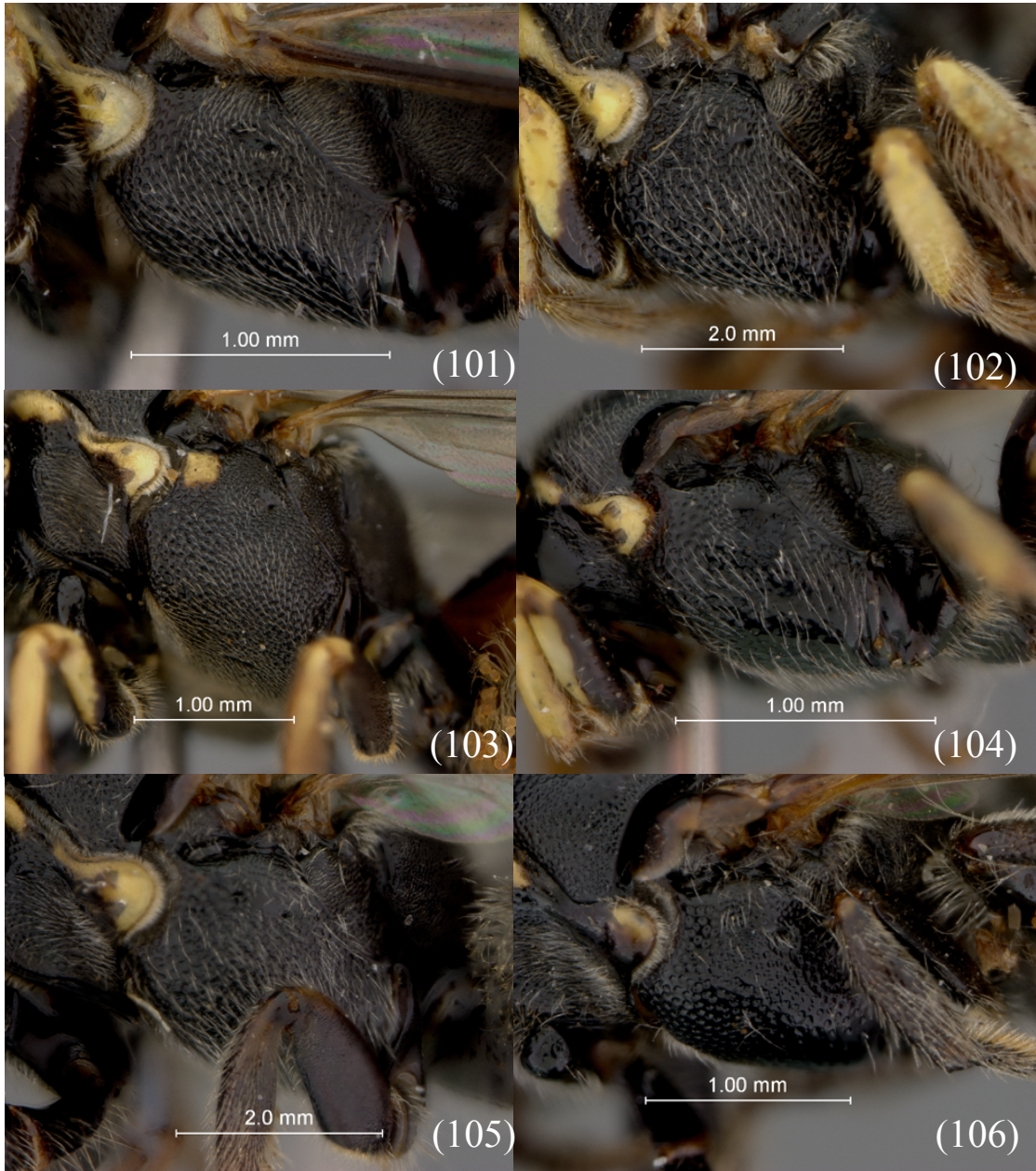

Figures 101-106. Female mesepisternums: *Ceratina pulchripes* (101), *C. punctigena* (102), *C. rugifrons* (103), *C. rugosoclypeata* new species (104), *C. simillima* (105), *C. sutepensis* (106)

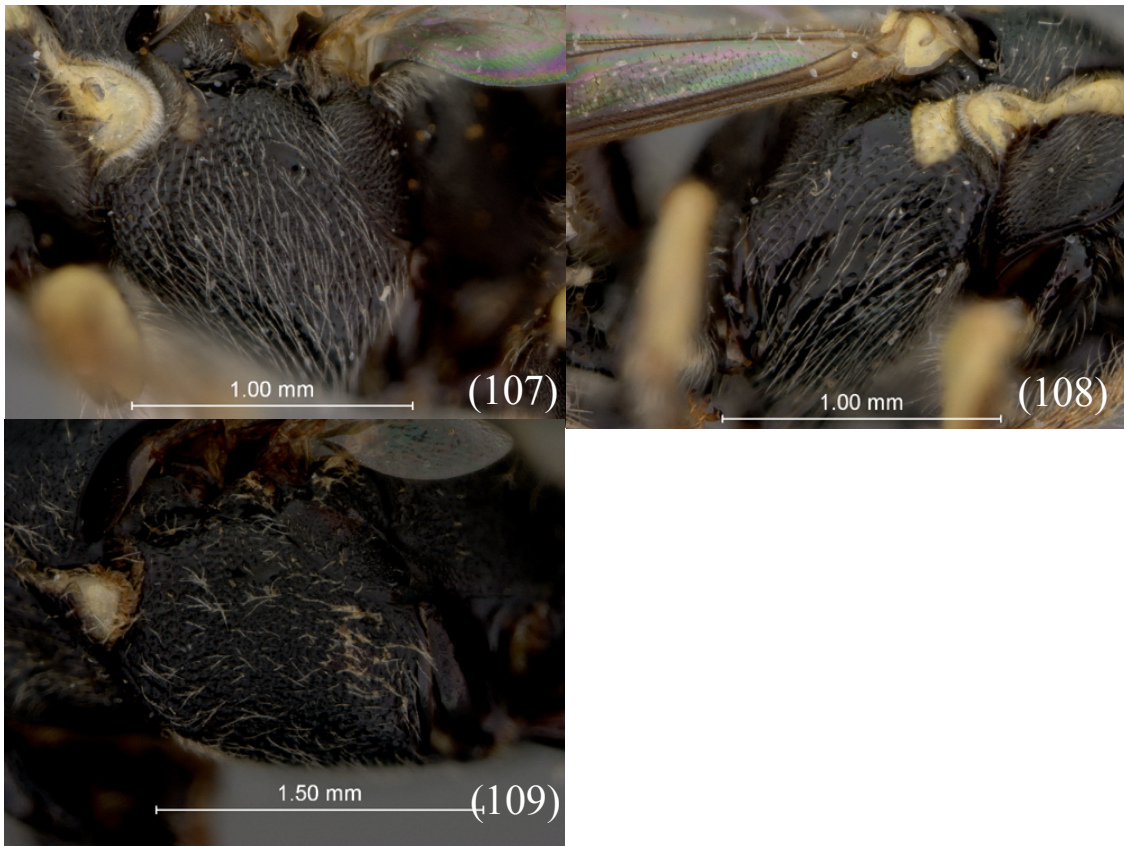

Figures 107-109. Female mesepisternums: *Ceratina taiwanensis* (107), *C. takasagona* (108), *C. tropica* (109)



Figures 110-115. Male faces: *Ceratina accusator* (110), *C. alpicola* (111), *C. bryanti* (112), *C. carinifrons* (113), *C. cognata* (114), *C. collusor* (115)

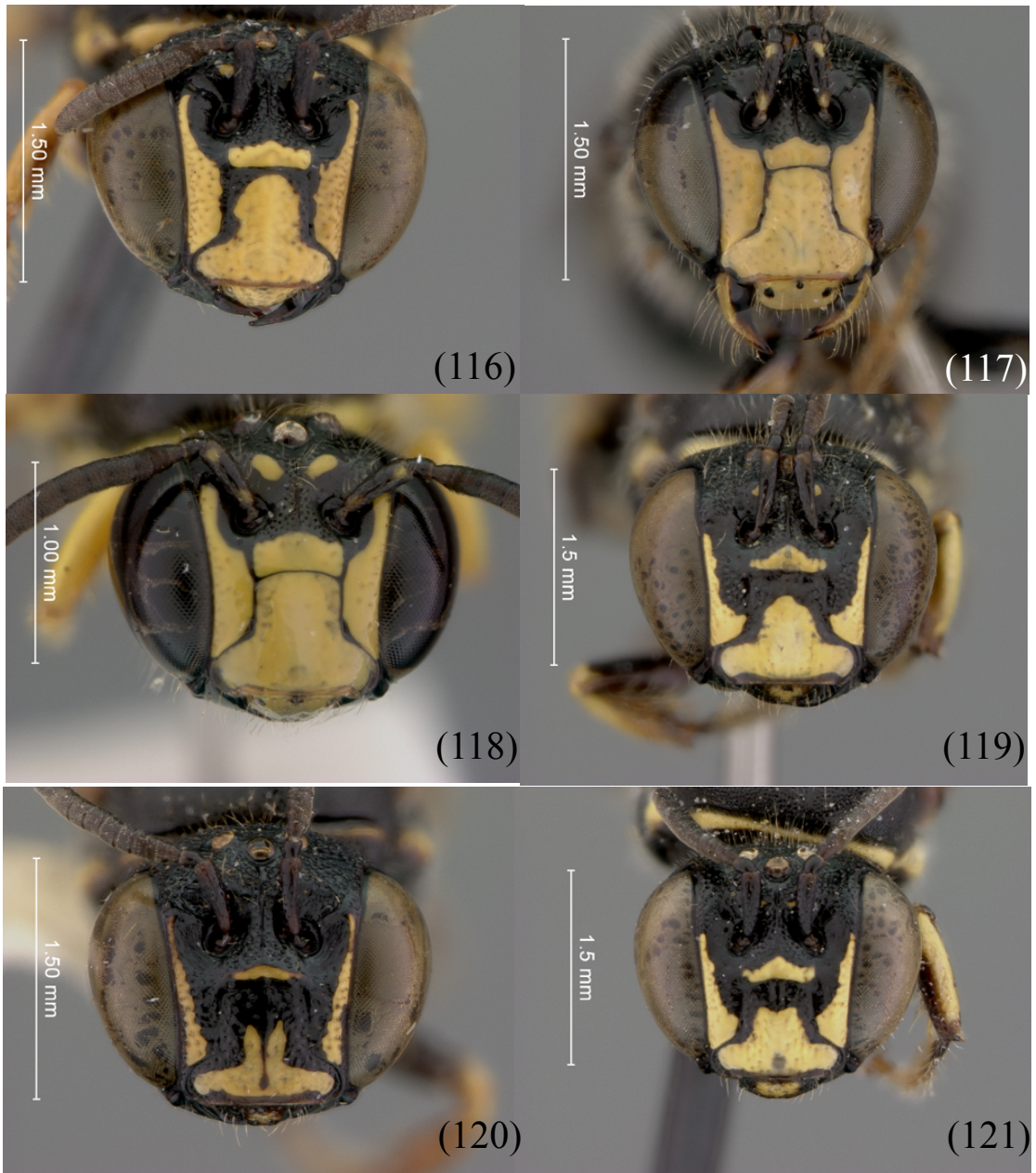

Figures 116-121. Male faces: *Ceratina compacta* (116), *C. flavipes* (117), *C. hieratica* (118), *C. lepida* (119), *C. interrupta* (120), *C. jacobsoni* (121)



Figures 122-127. Male faces: *Ceratina japonica* (122), *C. jejuensis* (123), *C. lieftincki* (124), *C. litoraria* (125), *C. malukuensis* new species (126), *C. moderata* (127)



Figures 128-133. Male faces: *Ceratina nigrolaterlis* (128), *C. okinawana okinawan* (129), *C. pulchripes* (130), *C. punctigena* (131), *C. rugifrons* (132), *C. rugosoclypeata* new species (133)

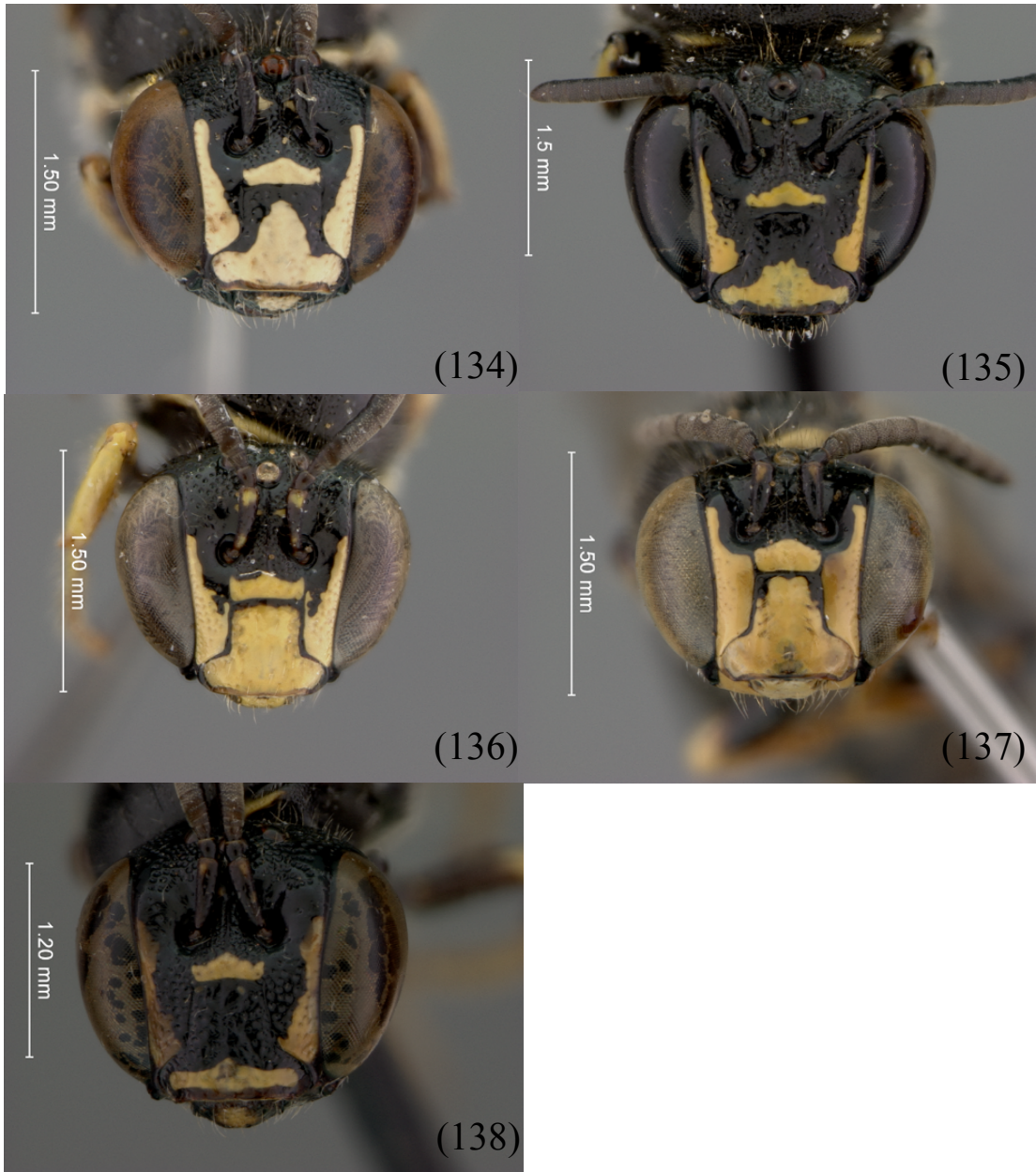

Figures 134-138. Male faces: *Ceratina simillima* (134), *C. sutepensis* (135), *C. taiwanensis* (136), *C. takasagona* (137), *C. tropica* (138)

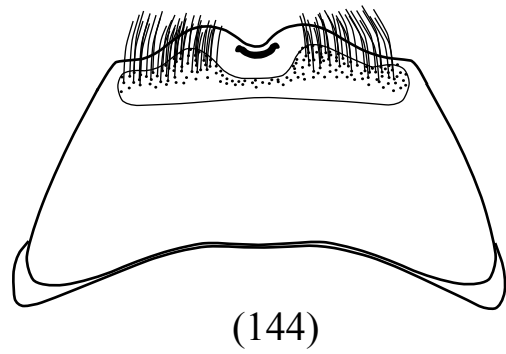
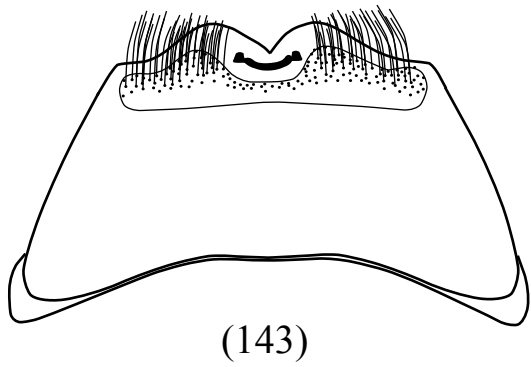
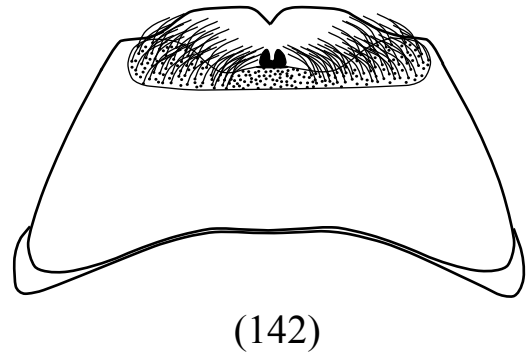
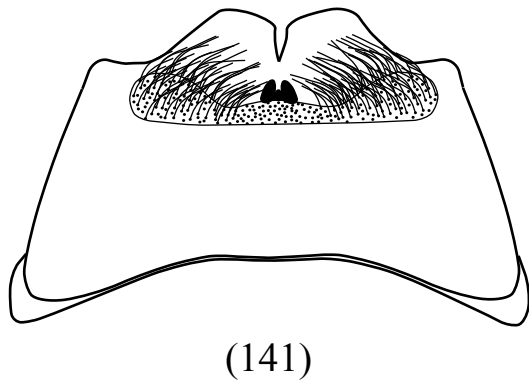
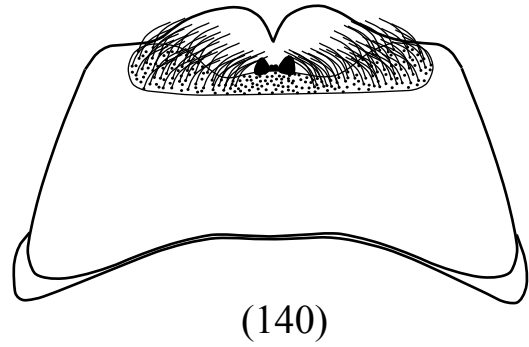
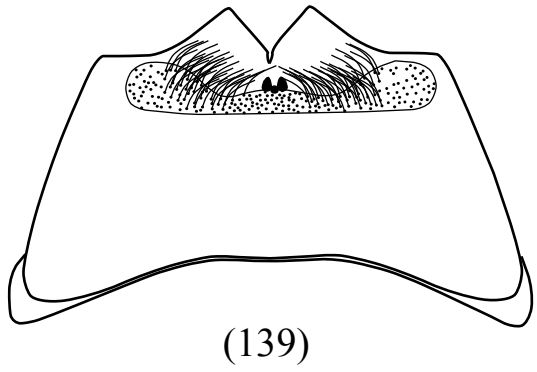

Figures 139-144. Male sixth sternite: *Ceratina accusator* (139), *C. alpicola* (140), *C. bryanti* (141), *C. carinifrons* (142), *C. cognata* (143), *C. collusor* (144)

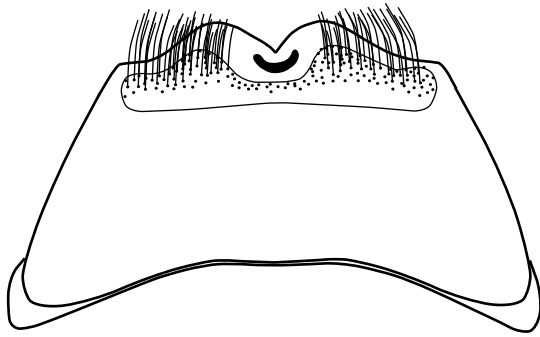

(145)

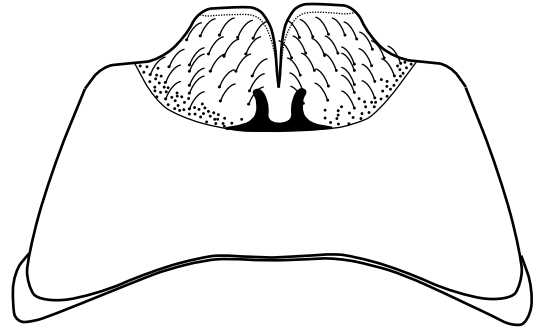

(146)

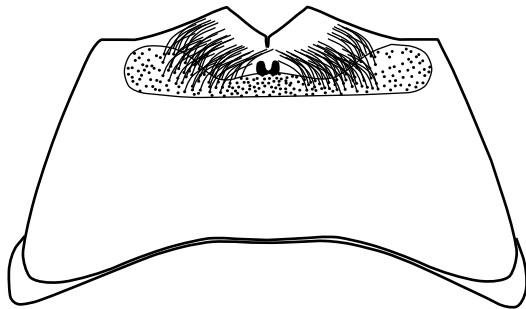

(147)

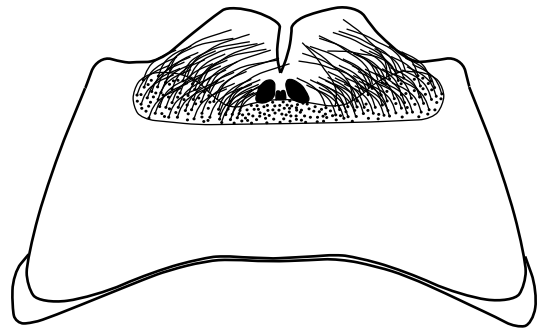

(148)

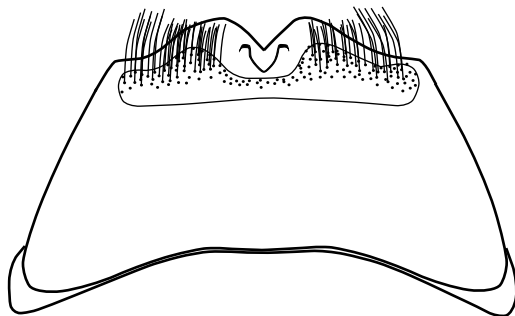

(149)

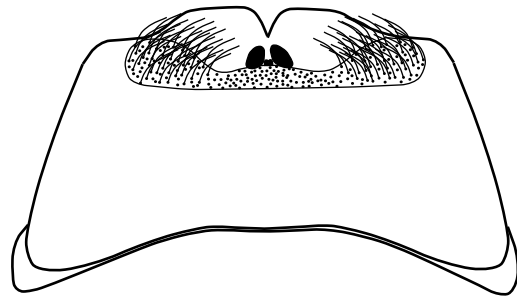

(150)

Figures 145-150. Male sixth sternite: *Ceratina compacta* (145), *C. flavipes* (146), *C. hieratica* (147), *C. lepida* (148), *C. interrupta* (149), *C. japonica* (150)

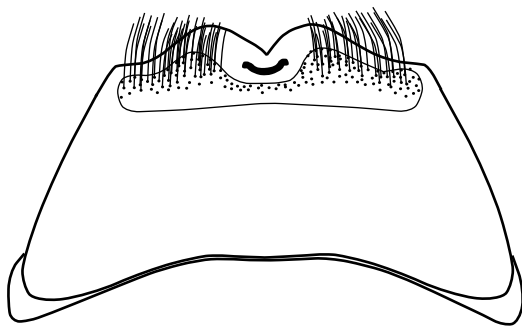

(151)

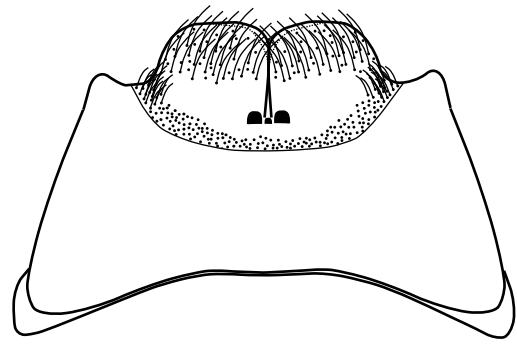

(152)

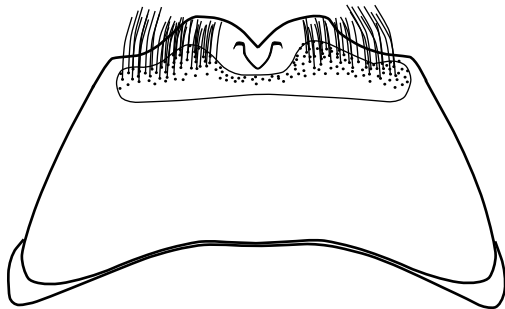

(153)

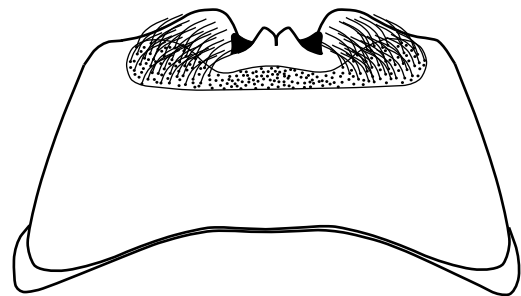

(154)

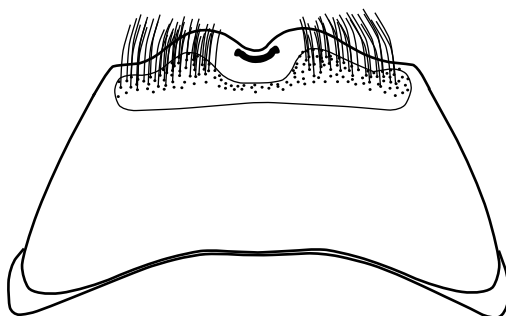

(155)

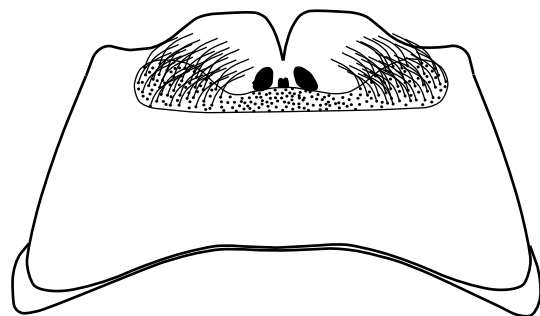

(156)

Figures 151-156. Male sixth sternite: *Ceratina lieftincki* (151), *C. litoraria* (152), *C. malukuensis* new species (153), *C. moderata* (154), *C. nigrolateralis* (155), *C. okinawana okinawana* (156)

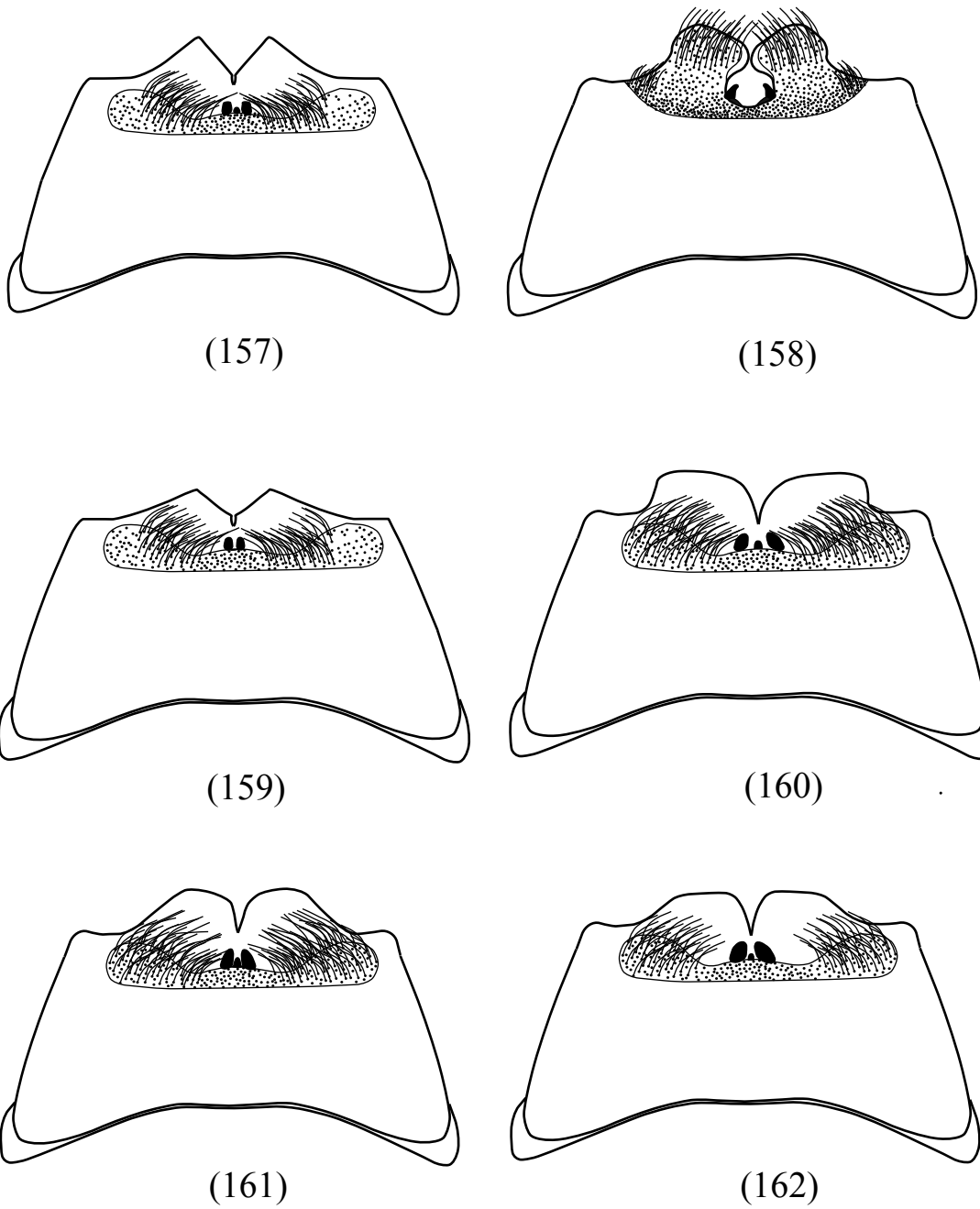

Figures 157-162. Male seventh terga: *Ceratina pulchripes* (157), *C. rugifrons* (158), *C. rugosoclypeata* new species (159), *C. simillima* (160), *C. sutepensis* (161), *C. taiwanensis* (162)

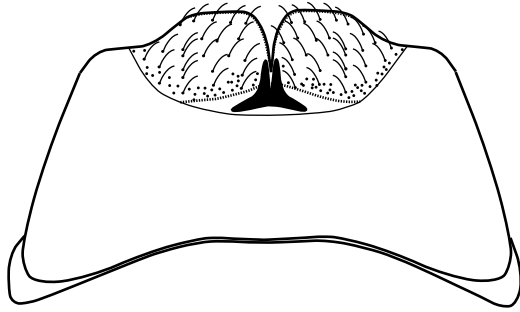

(163)

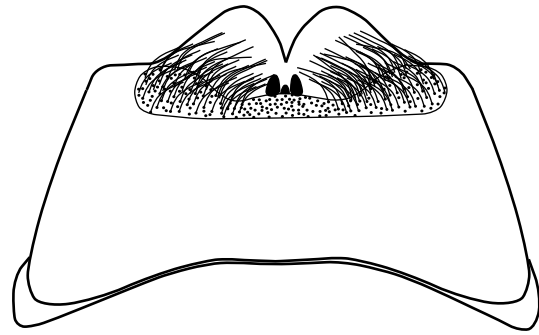

(164)

Figures 163-164. Male seventh terga: *Ceratina takasagona* (163) and *C. tropica* (164)

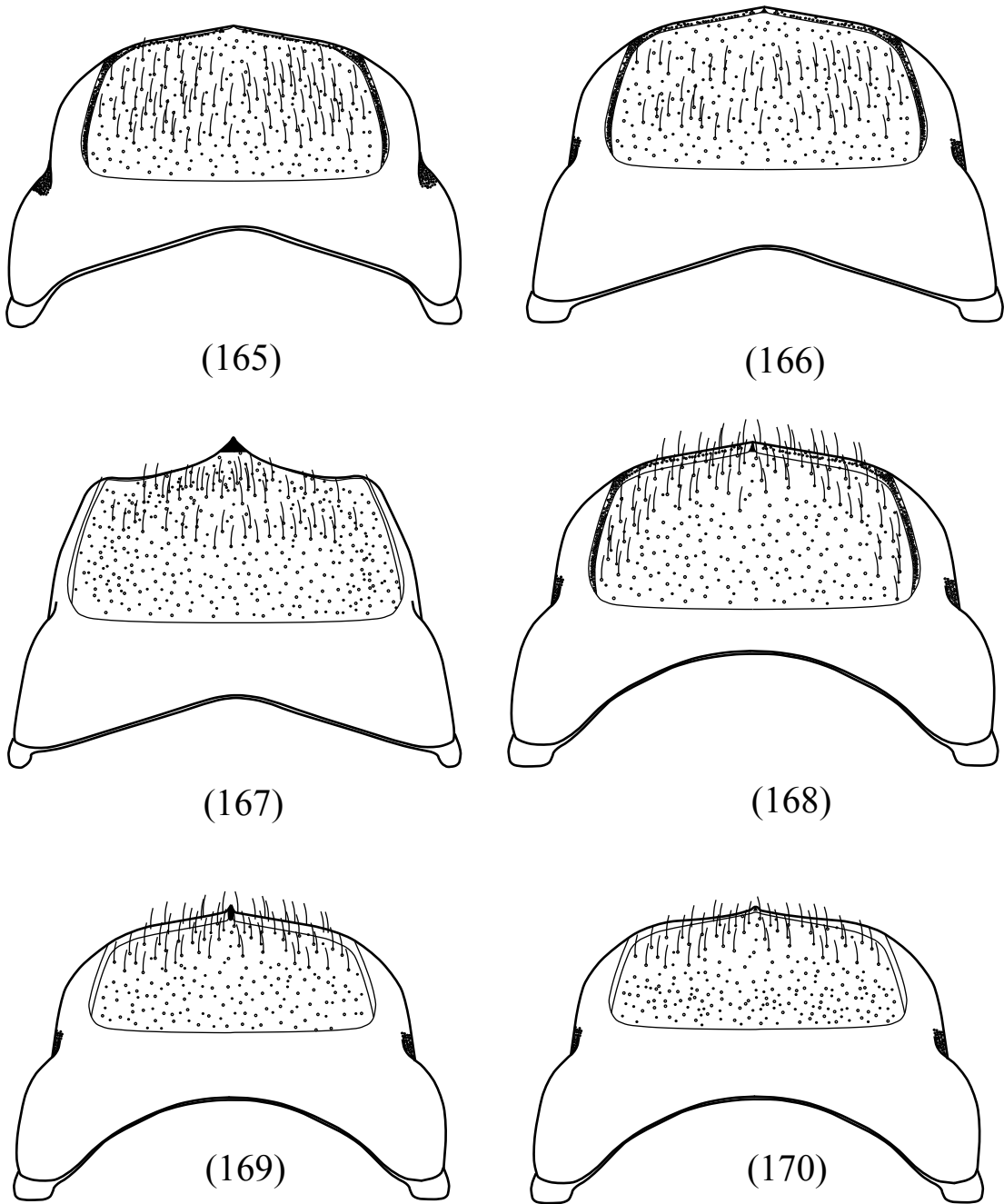

Figures 165-170. Male seventh terga: *Ceratina accusator* (165), *C. alpicola* (166), *C. bryanti* (167), *C. carinifrons* (168), *C. cognata* (169), *C. collusor* (170)

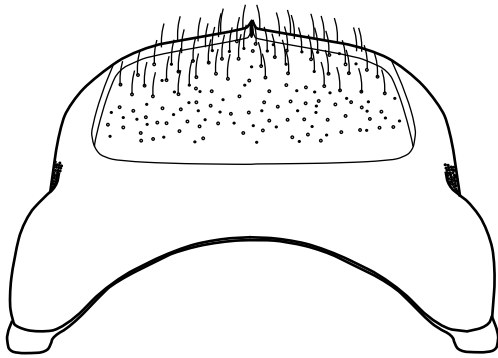

(171)

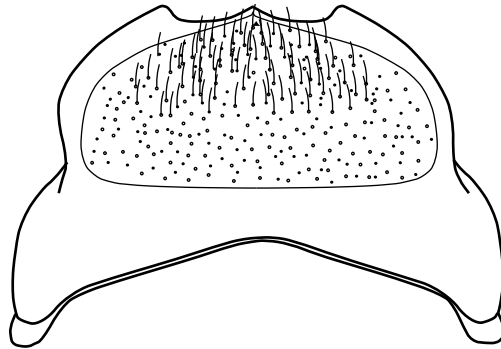

(172)

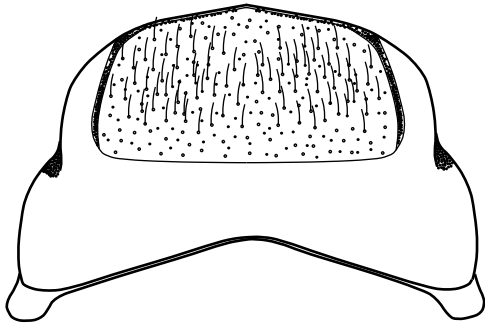

(173)

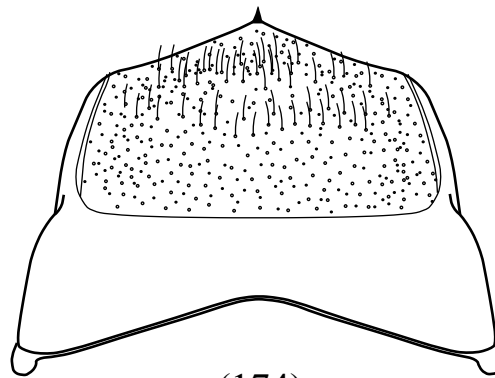

(174)

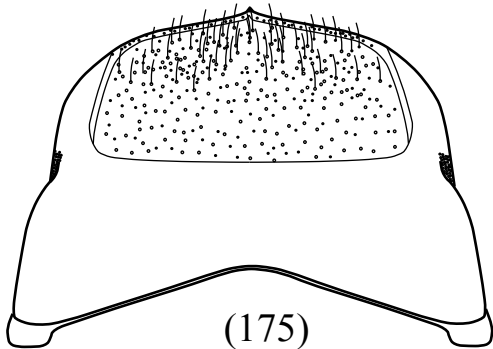

(175)

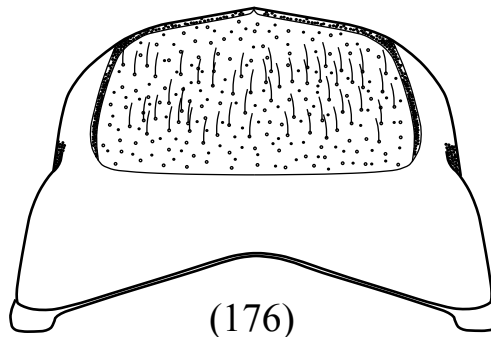

(176)

Figures 171-176. Male seventh terga: *Ceratina compacta* (171), *C. flavipes* (172), *C. hieratica* (173), *C. lepida* (174), *C. interrupta* (175), *C. japonica* (176)

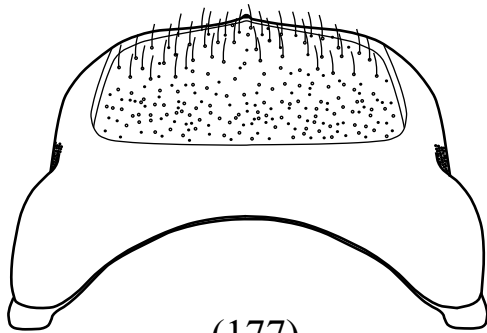

(177)

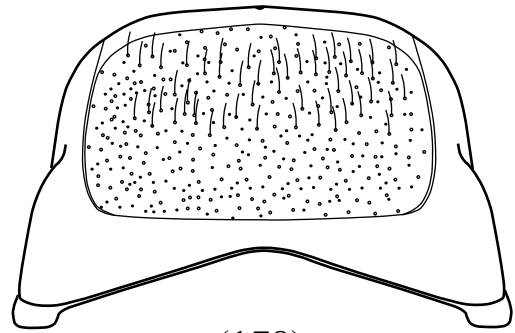

(178)

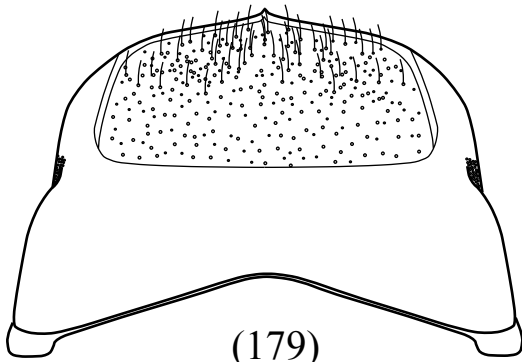

(179)

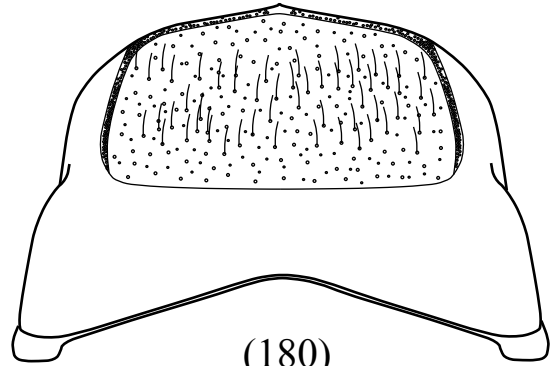

(180)

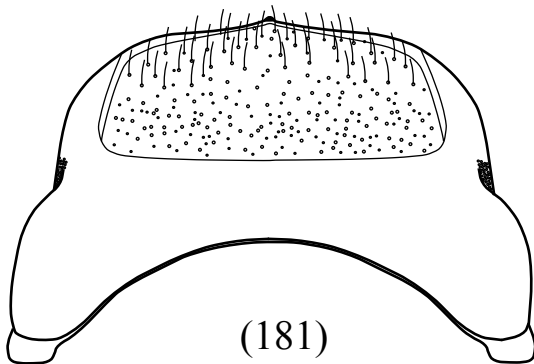

(181)

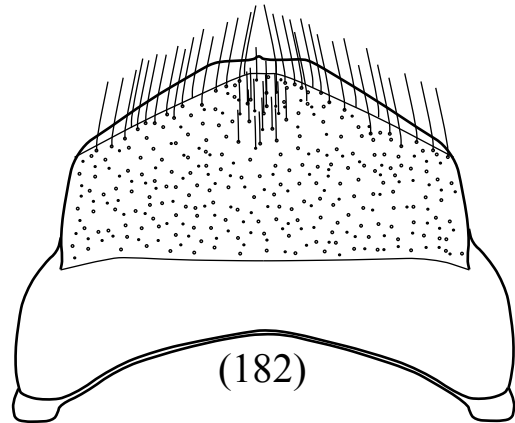

(182)

Figures 177-182. Male seventh terga: *Ceratina lieftincki* (177), *C. litoraria* (178), *C. malukuensis* new species (179), *C. moderata* (180), *C. nigrolateralis* (181), *C. okinawana okinawana* (182)

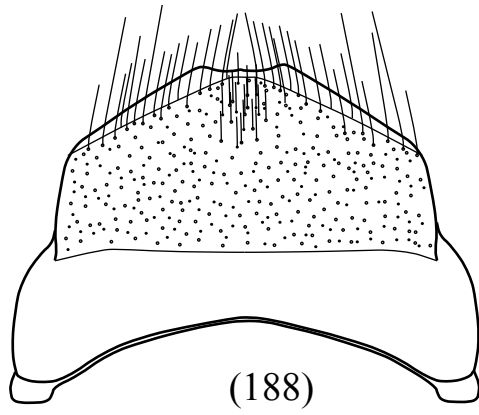
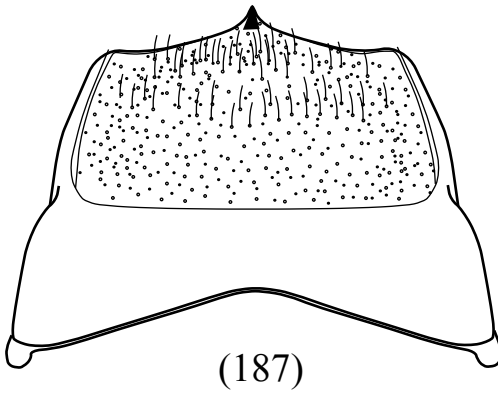
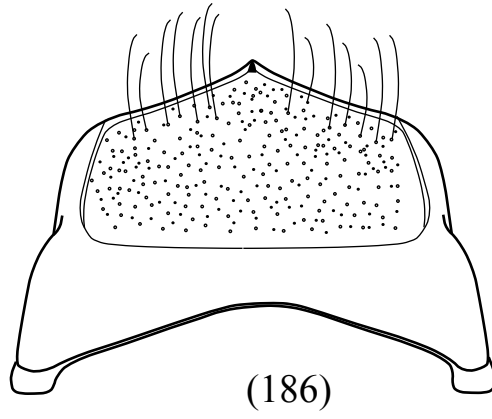
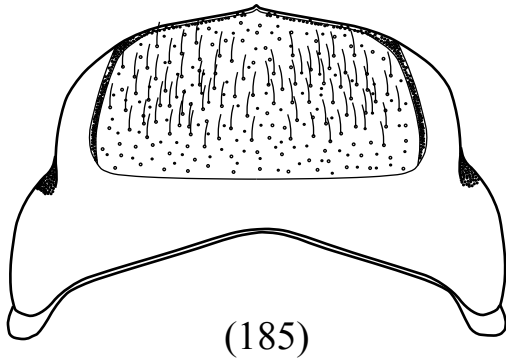
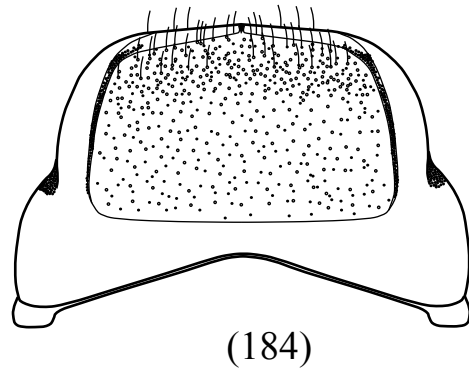
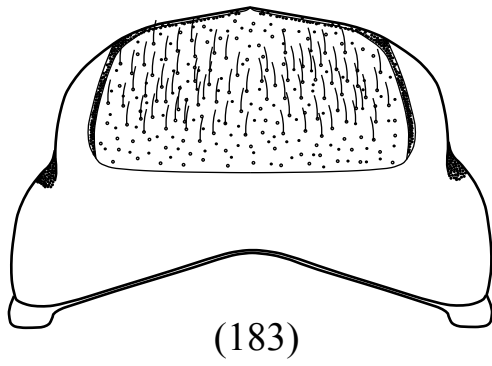

Figures 183-188. Male seventh terga: *Ceratina pulchripes* (183), *C. rugifrons* (184), *C. rugosochlypeata* new species (185), *C. simillima* (186), *C. sutepensis* (187), *C. taiwanensis* (188)

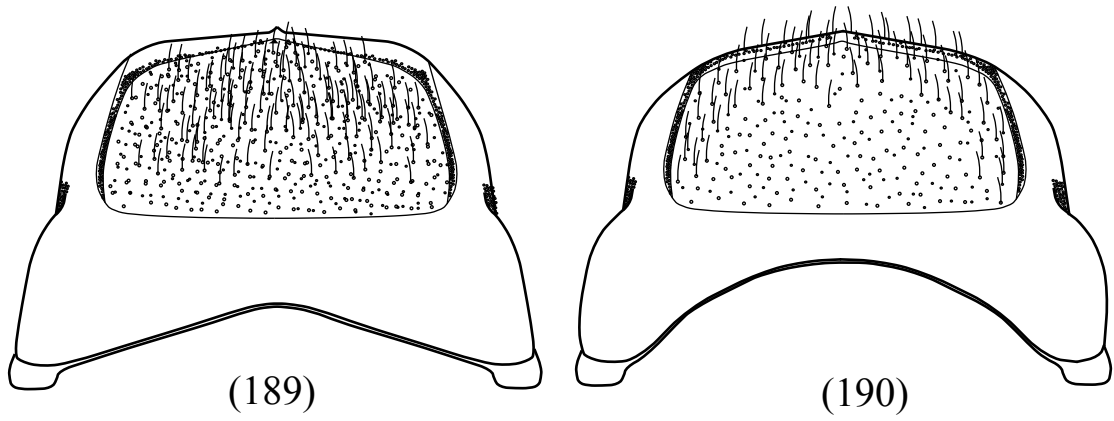

Figures 189-190. Male seventh terga: *Ceratina takasagona* (189) and *C. tropica* (190)

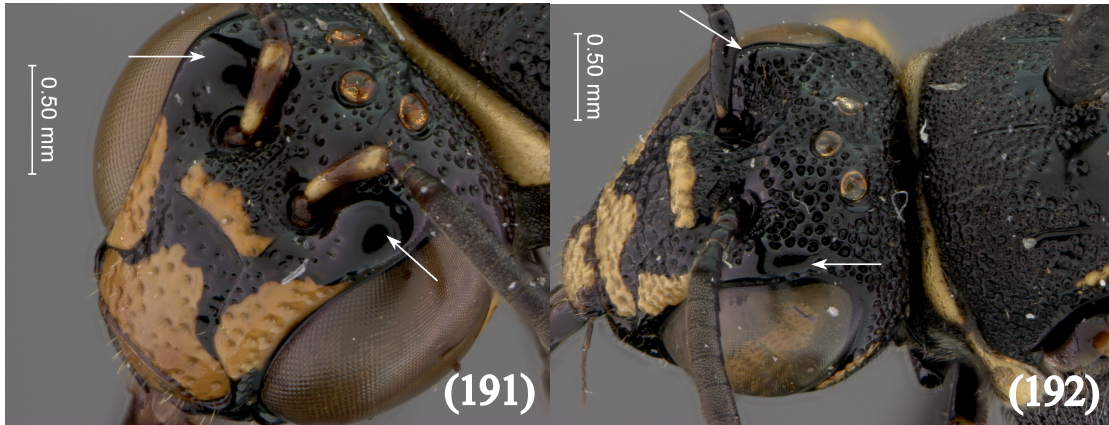

Figures 191-192. Convex impunctate areas near eye margins: *Ceratina carinifrons* (191), *C. rugifrons* (192)

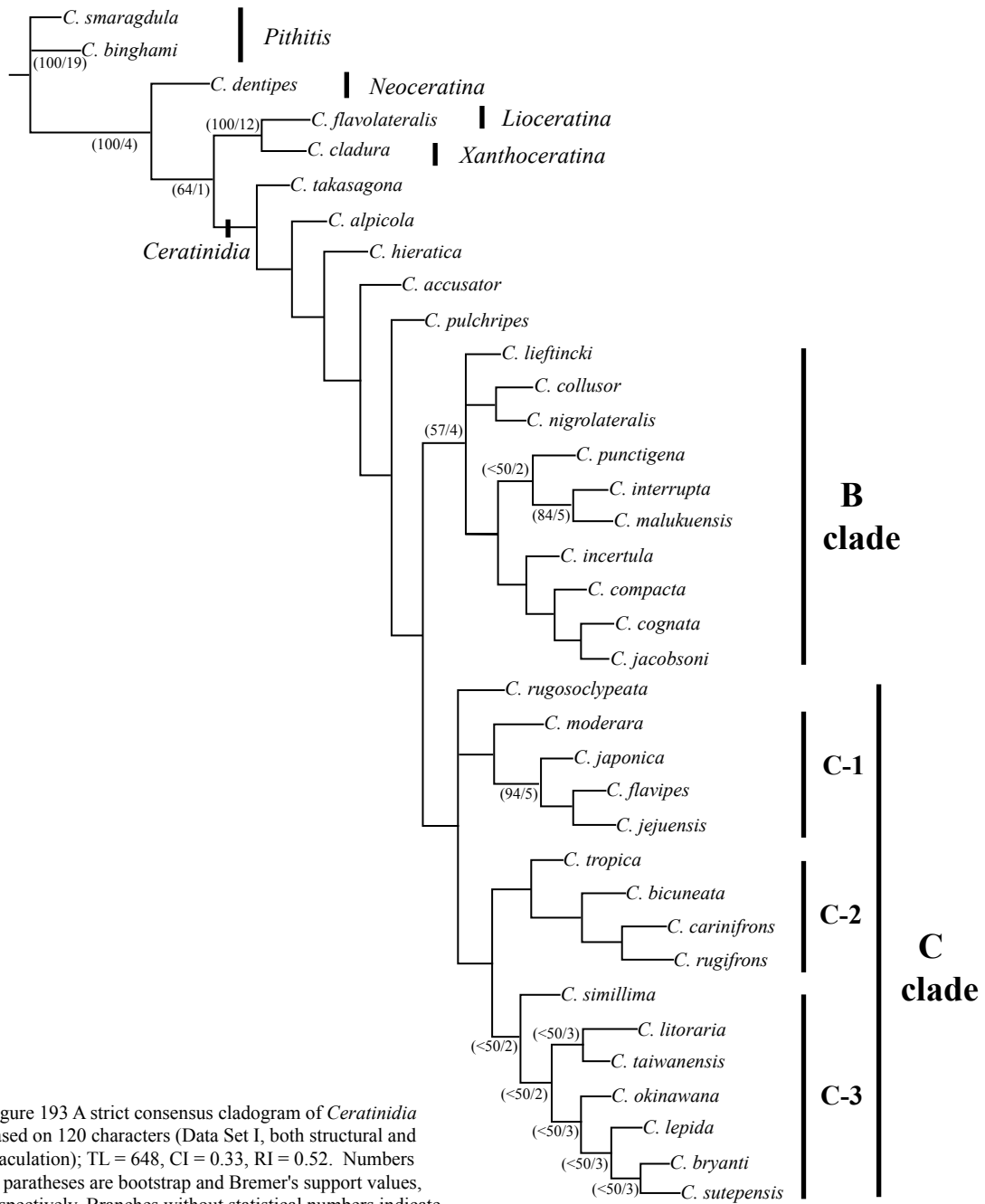

Figure 193 A strict consensus cladogram of *Ceratinidia* based on 120 characters (Data Set I, both structural and maculation); TL = 648, CI = 0.33, RI = 0.52. Numbers in parentheses are bootstrap and Bremer's support values, respectively. Branches without statistical numbers indicate bootstrap value below 50% and 1 Bremer's value.

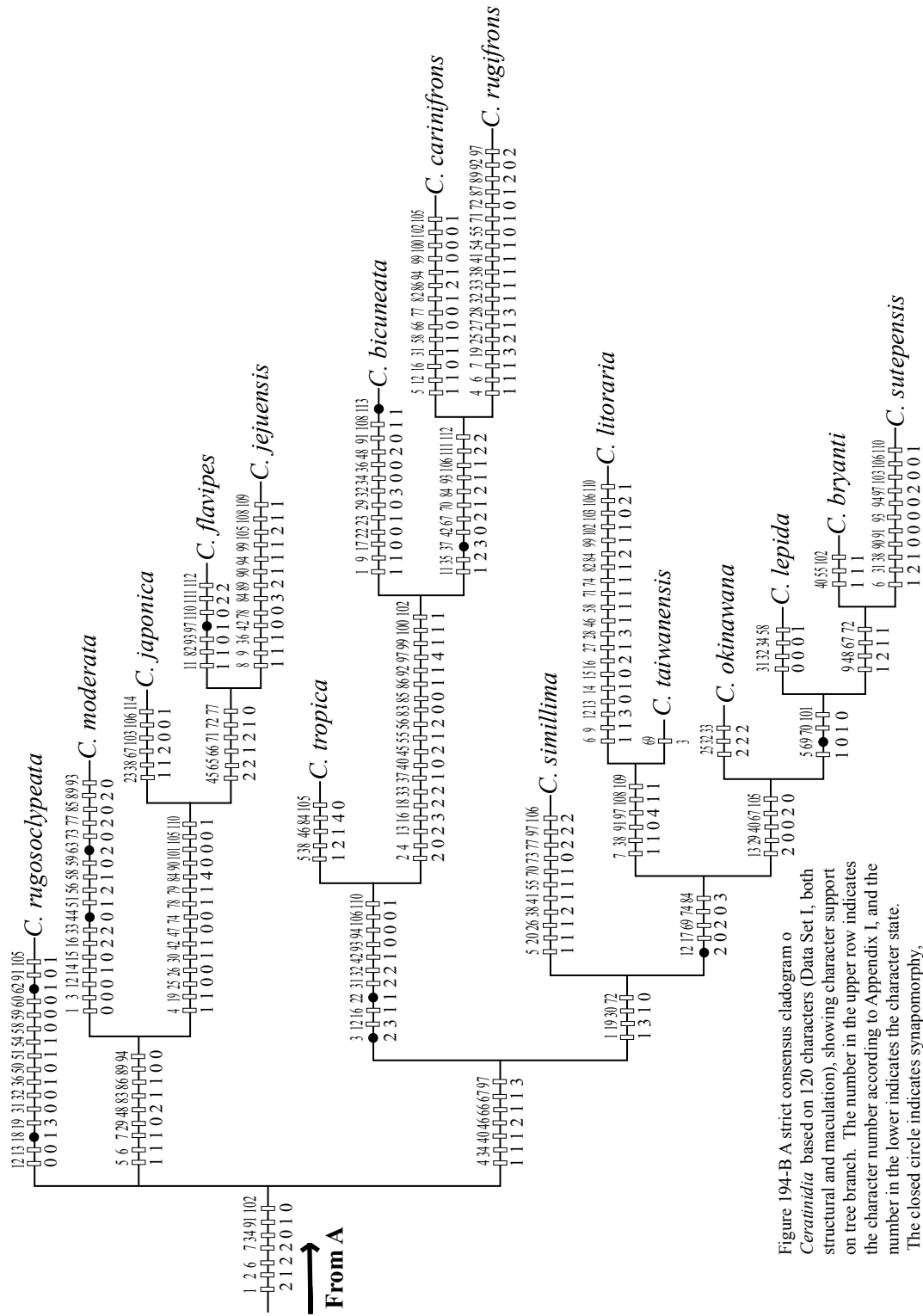

Figure 194-B A strict consensus cladogram of *Ceratimidia* based on 120 characters (Data Set I, both structural and maculation), showing character support on tree branch. The number in the upper row indicates the character number according to Appendix I, and the number in the lower row indicates the character state. The closed circle indicates synapomorphy, and the opened rectangle indicates homoplasy or reversal character.

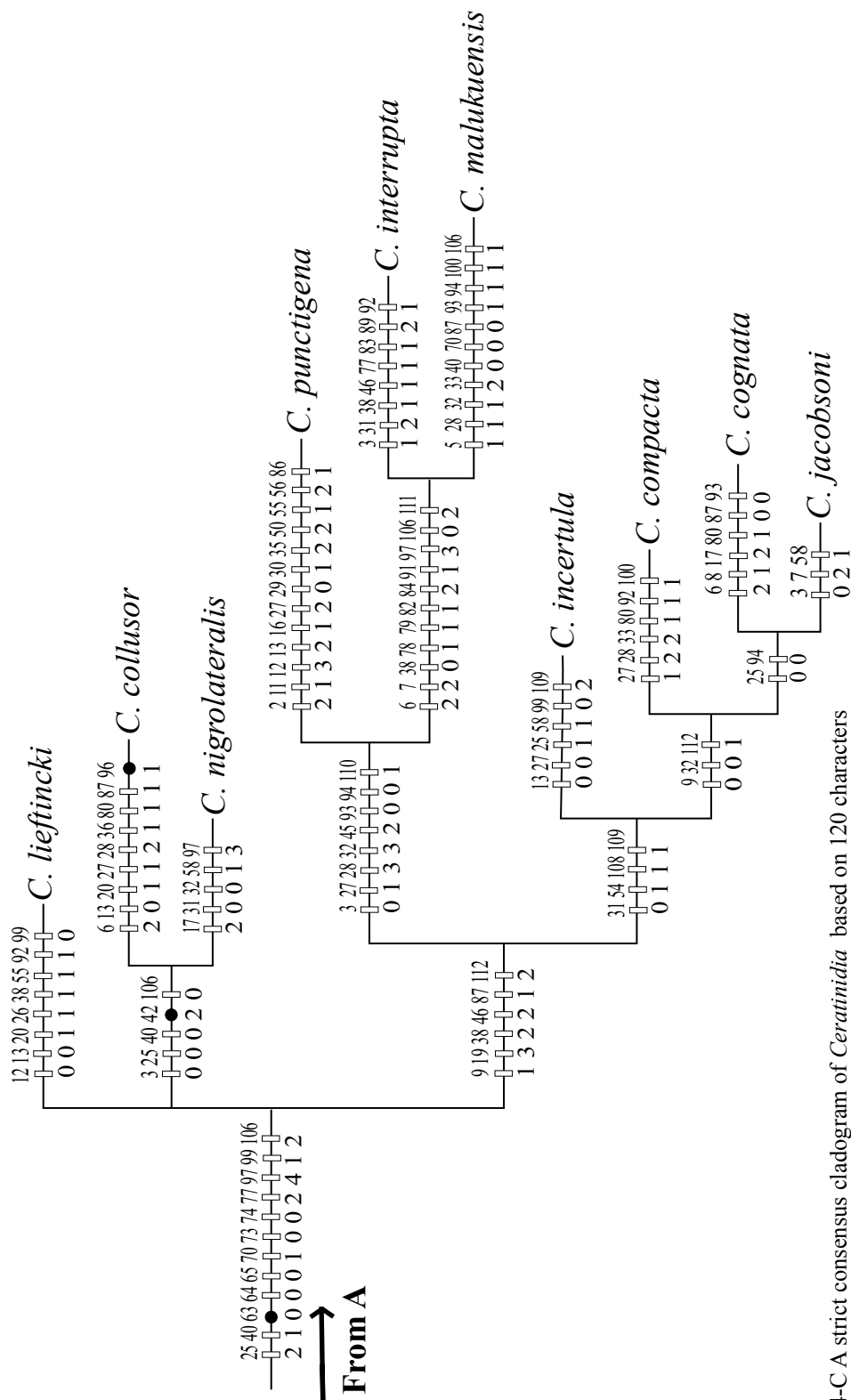
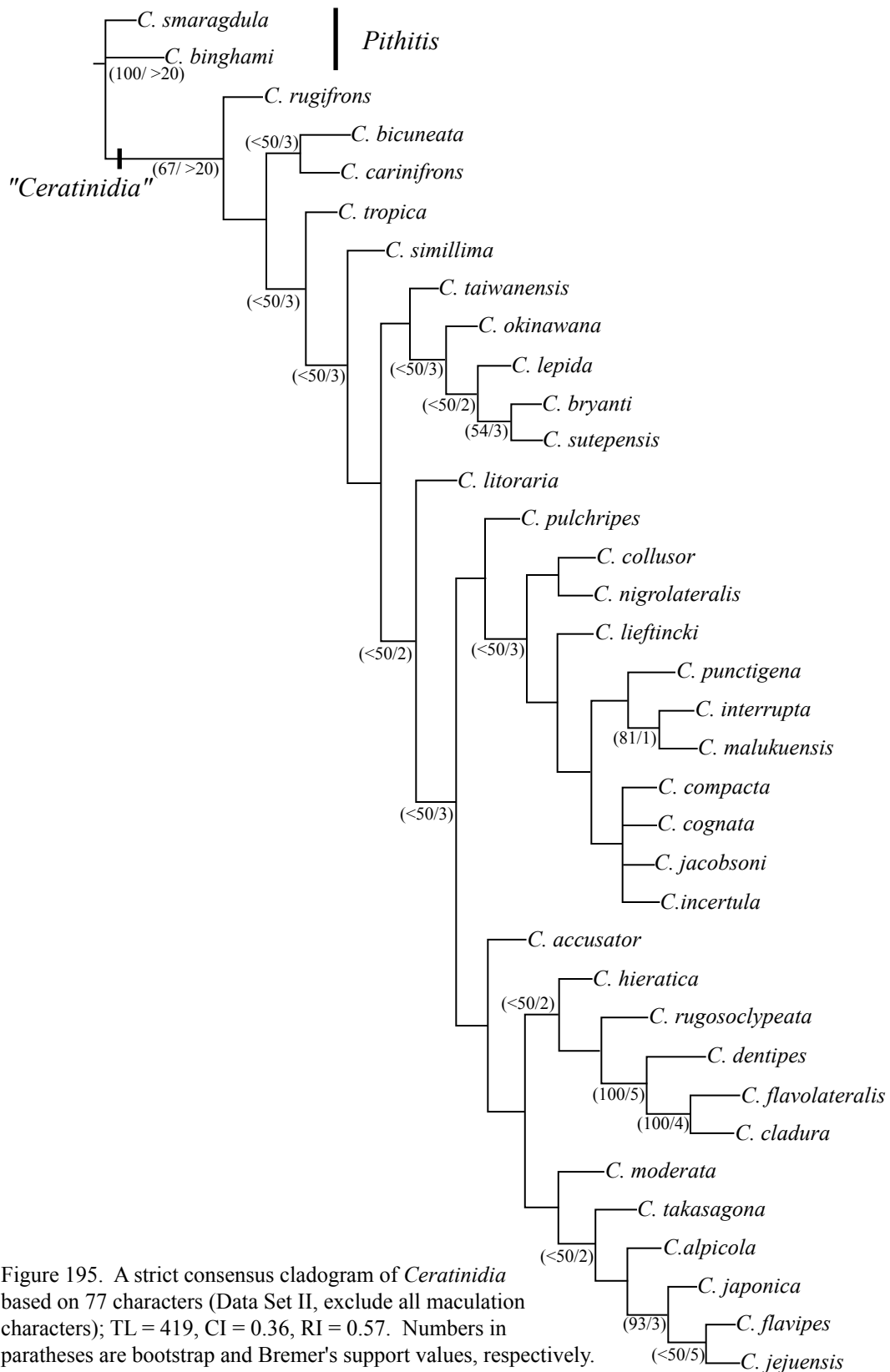

Figure 194-C A strict consensus cladogram of *Ceratinidia* based on 120 characters (Data Set I, both structural and maculation), showing character support on tree branch. The number in the upper row indicates the character number according to Appendix I, and the number in the lower row indicates the character state. The closed circle indicates synapomorphy, and the opened rectangle indicates homoplasy or reversal character.



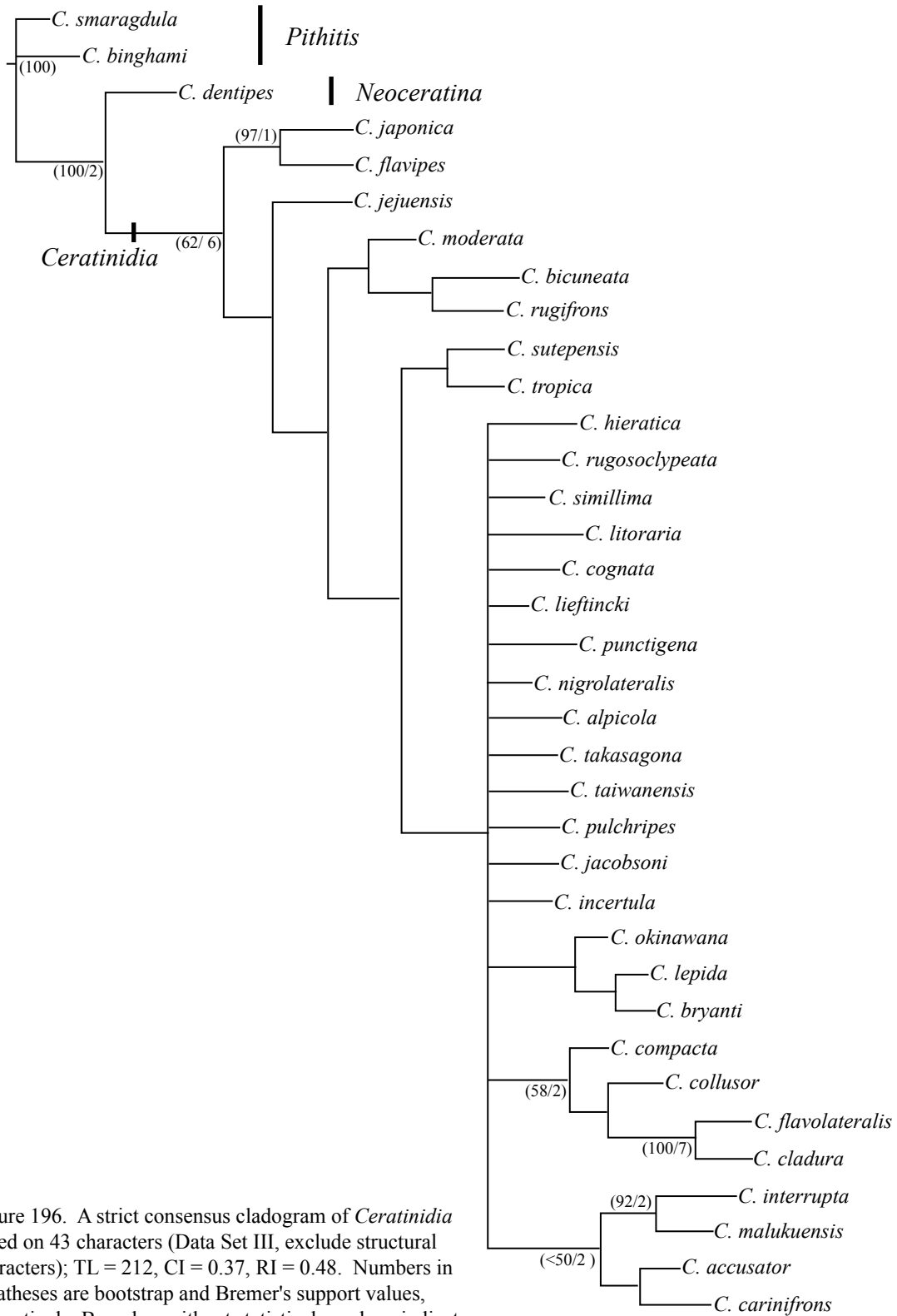

Figure 196. A strict consensus cladogram of *Ceratinidia* based on 43 characters (Data Set III, exclude structural characters); TL = 212, CI = 0.37, RI = 0.48. Numbers in paratheses are bootstrap and Bremer's support values, respectively. Branches without statistical numbers indicate bootstrap value below 50% and 1 Bremer's value.

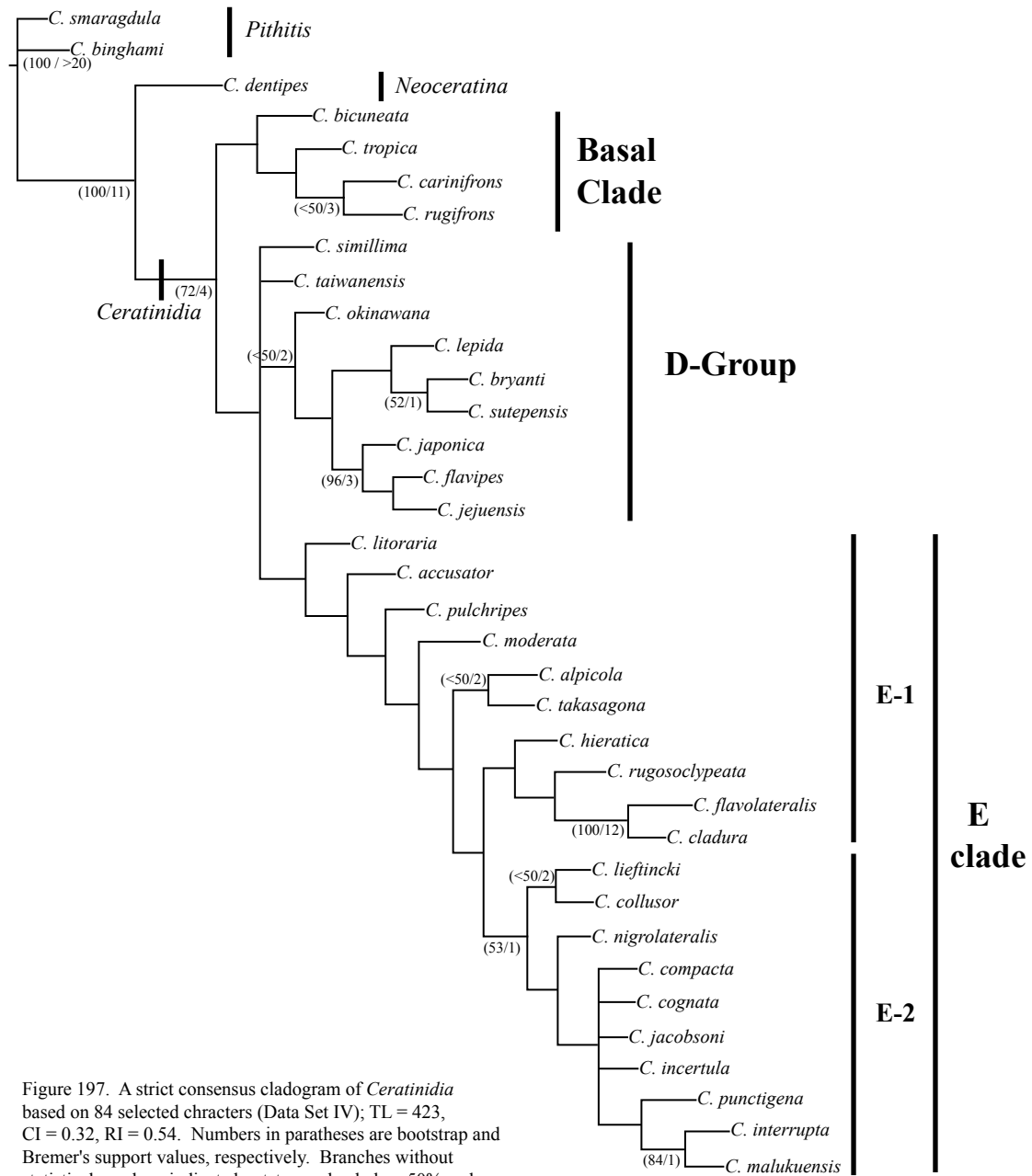

Figure 197. A strict consensus cladogram of *Ceratinidia* based on 84 selected characters (Data Set IV); TL = 423, CI = 0.32, RI = 0.54. Numbers in parentheses are bootstrap and Bremer's support values, respectively. Branches without statistical numbers indicate bootstrap value below 50% and 1 Bremer's value.

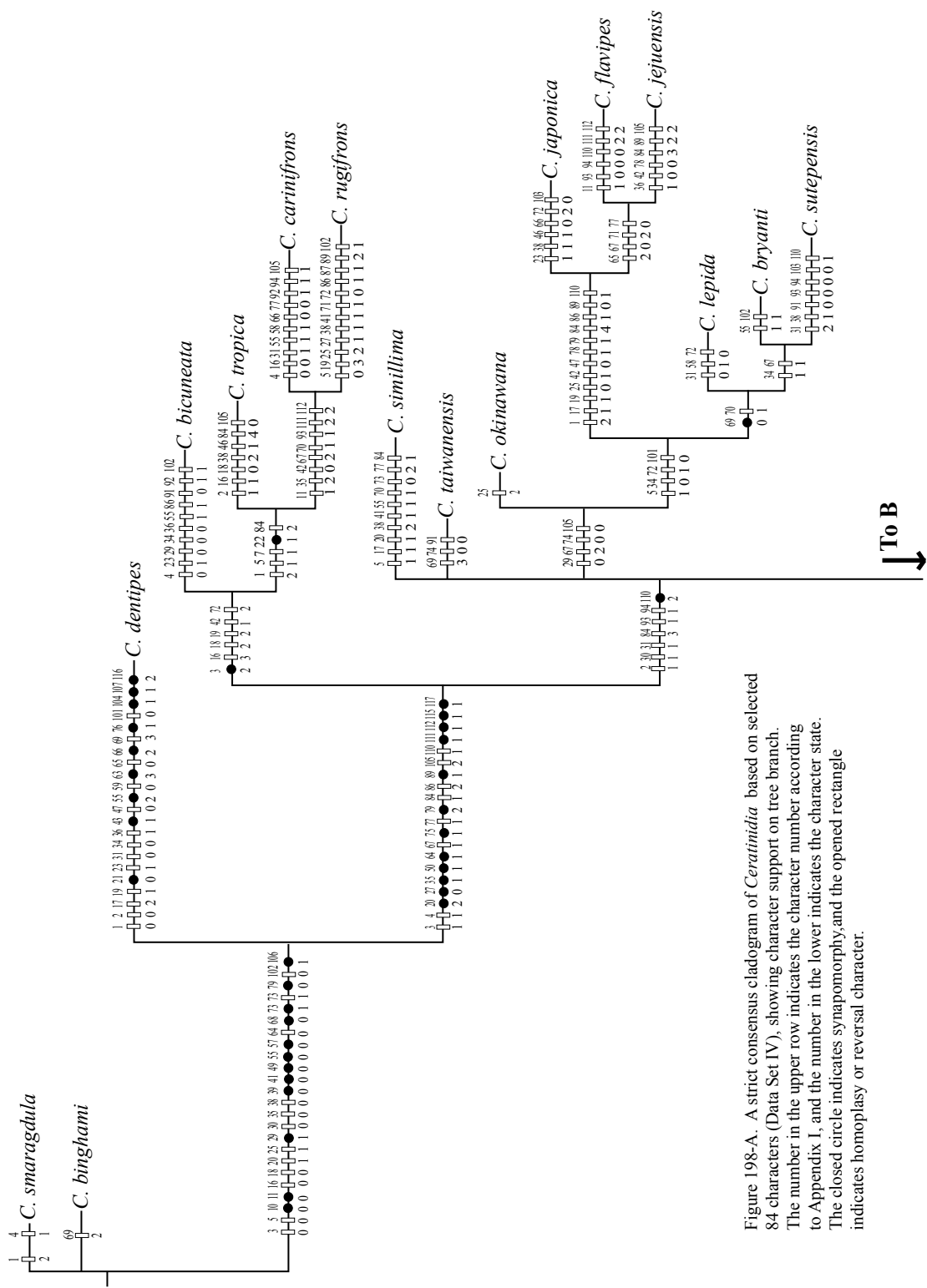

Figure 198-A. A strict consensus cladogram of *Ceratinidia* based on selected 84 characters (Data Set IV), showing character support on tree branch. The number in the upper row indicates the character number according to Appendix I, and the number in the lower indicates the character state. The closed circle indicates synapomorphy, and the opened rectangle indicates homoplasy or reversal character.



Figure 198-B. A strict consensus cladogram of *Ceratimidia* based on selected 84 characters (Data Set IV), showing character support on tree branch. The number in the upper row indicates the character number according to Appendix I, and the number in the lower indicates the character state. The closed circle indicates synapomorphy, and the opened rectangle indicates homoplasy or reversal character.

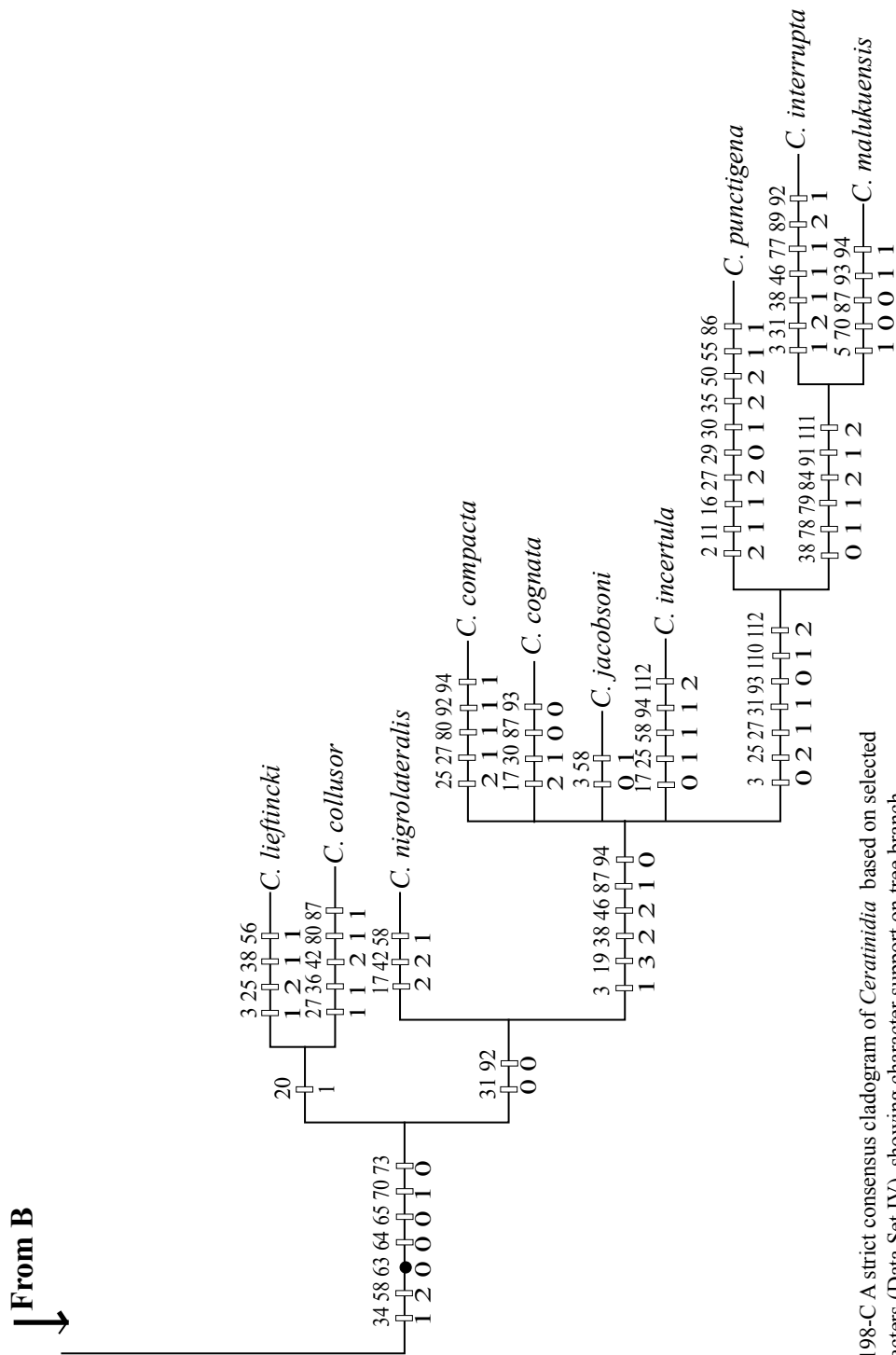

Figure 198-C A strict consensus cladogram of *Ceratimidia* based on selected 84 characters (Data Set IV), showing character support on tree branch. The number in the upper row indicates the character number according to Appendix I, and the number in the lower row indicates the character state. The closed circle indicates synapomorphy, and the opened rectangle indicates homoplasy or reversal character.

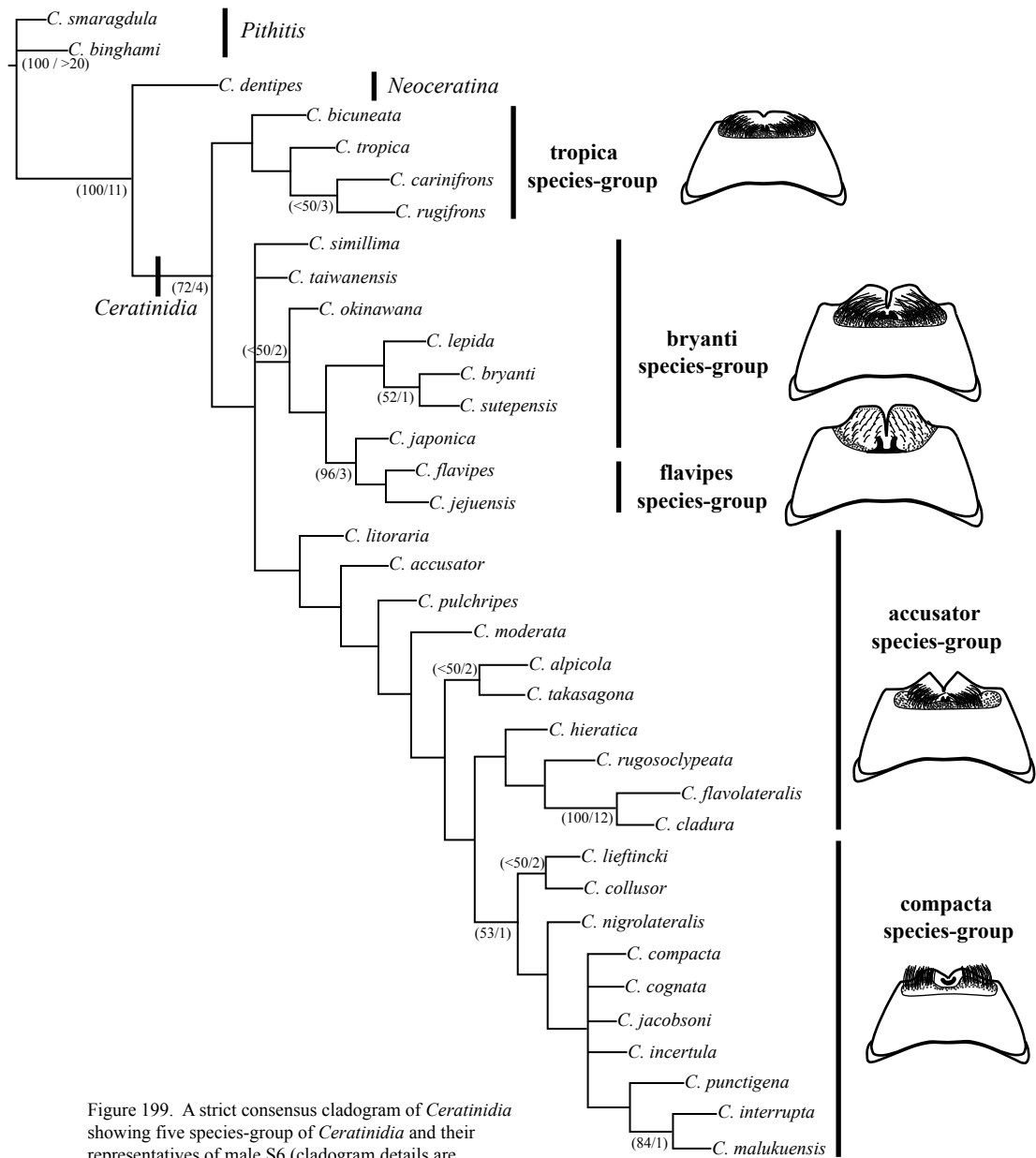

Figure 199. A strict consensus cladogram of *Ceratinidia* showing five species-group of *Ceratinidia* and their representatives of male S6 (cladogram details are explained in Figure 198-A-C).

APPENDIX I

Characters used in cladistic analyses (* indicates omitted characters in Data Set IV)

Clypeus

- (1) *Surface of clypeus as a whole*: smooth or slightly rugose (0), partially rugose (1), strongly rugose (2)
- (2) *Density of punctures on clypeus*: impunctate or few scattered punctures, mostly on dorsal and dorsolateral margins of clypeus (0), partially densely punctate (1), densely punctate throughout (2)
- (3) *Size of punctures*: small to fine (0), medium-sized (1), coarse but puncture margins not strongly demarcated (2), coarse and puncture margins strongly demarcated (3)
- (4) *Surface of median area of clypeus*: not longitudinally impressed or impressed area vague (0), impressed area strong (1)
- (5) *Median longitudinal carina*: absent or vague (0), present (1)

Labrum

- (6)* *Density of punctures on labrum*: impunctate or with few punctures (0), scattered punctate (1), densely punctate throughout (2)
- (7)* *Size of punctures*: small to fine (0), medium-sized (1), coarse but puncture margin not strongly demarcated (2), coarse and puncture margins strongly demarcated (3)
- (8)* *Density of bristles*: scattered (0), dense (1)
- (9)* *Length of bristles*: short (0), long (1)

Base of mandible (10): without basal depression (0), with distinct depression basally (1)

Paraocular area below antennal fossa

- (11) *Surface of paraocular area*: smooth and shiny or slightly rugose (0), strongly rugose (1)
- (12)* *Density of punctures on paraocular area*: impunctate or few scattered punctures (0), scattered punctures (1), partially densely punctate, mostly on median area (2), densely punctate throughout (3)
- (13)* *Size of punctures*: small and fine (0), medium-sized (1), coarse but puncture margin not strongly demarcated (2), coarse and puncture margin strongly demarcated (3)

Antennal fossa area

- (14) *Density of punctures along frontal carina*: impunctate or few scattered punctures (0), sparsely punctate (1), densely punctate (2)

- (15)* *Size of punctures along frontal carina*: small to medium-sized (0), medium-sized to large (1), coarse and puncture margins strongly demarcated (2)
- (16) *Punctures on outer side of antennal fossa*: absent or few (0), scattered punctures (1), dense puncture on dorsolateral area (2), densely punctate throughout (3)

Invagination on dorsolateral area of antennal fossa (17): absent (0), small (1), large and conspicuous (2)

Supraclypeal area (18): punctures absent, or with few punctures (0), scattered punctures (1), densely punctate (2)

Frontal and vertex area

- (19) *Density of punctures on frontal area*: impunctate or few scattered punctures (0), scattered punctures (1), clump of punctures (2), densely punctate (3)
- (20) *Size of punctures on frontal area*: absent (0), medium-sized (1), coarse but puncture margins not strongly demarcated (2), coarse and puncture margins strongly demarcated (3)
- (21) *Surface area on median part of frons*: slightly raised and flattened subcircular (0), flattened blend well with adjacent area (1)
- (22) *Area between upper compound eye margin and dorsolateral area of antennal fossa*: not swollen (0), swollen (1)
- (23) *Density of punctures on vertex area*: impunctate or few scattered punctures (0), sparsely punctate (1), densely punctate (2)
- (24)* *Size of punctures on vertex*: small to fine (0), medium-sized (1), coarse but puncture margins not strongly demarcated (2), coarse and puncture margin strongly demarcated (3)

Area between lateral ocelli and upper margin of compound eye

- (25) *Density of punctures*: impunctate or few scattered punctures (0), sparsely punctate (1), densely punctate (2)
- (26)* *Size of punctures*: small to fine (0), medium-sized (1), coarse but puncture margin not strongly demarcated (2), coarse and puncture margin strongly demarcated (3)

Genal area

- (27) *Density of punctures*: impunctate or few punctures (0), scattered punctures (1), densely punctate (2)
- (28)* *Size of punctures*: absent (0), small to fine (1), medium-sized (2), coarse but puncture margins not strongly demarcated (3), coarse and puncture margin strongly demarcated (4)

Structure of vertex

- (29) *Surface of vertex*: nearly flat (0), curved downward, i.e., depressed (1)
- (30) *Preoccipital carina*: not distinct (0), distinct (1)

Hypostomal area

- (31) *Density of punctures*: impunctate or few scattered punctures (0), scattered punctures (1), densely punctate (2)
- (32)* *Size of punctures*: absent (0), small to fine (1), medium-sized (2), coarse but puncture margins not strongly demarcated (3), coarse and puncture margin strongly demarcated (4)
- (33)* *Hypostomal carina*: absent (0), weak not conspicuous (1), prominent without lateral arm (2), prominent with lateral arm (3)

Scutum

- (34) *Density of punctures on anterior portion*: scattered (0), dense (1)
- (35) *Size of punctures on anterior portion*: small and fine (0), medium-sized (1), coarse but puncture margins not strongly demarcated (2), coarse and puncture margin strongly demarcated (3)
- (36) *Density of punctures on posterior portion*: absent or with few punctures (0), scattered (1), dense (2)
- (37)* *Size of punctures on posterior portion*: absent (0), small and fine (1), medium-sized (2), coarse but puncture margin not strongly demarcated (3), coarse and puncture margin strongly demarcated (4)
- (38) *Punctures on area between lateral margin of scutum and parapsidal furrow*: absent or few (0), scattered (1), dense (2)
- (39) *Punctures on area between the two parapsidal furrows*: partially or wholly impunctate (0), densely punctate (1)
- (40)* *Punctures along anteromedian line*: absent or few (0), one or more rows of punctures present (1)

Procoxa

- (41) *Shape of procoxa*: more or less rectangular (0), triangular (1)
- (42) *Ventrolateral process of procoxa*: absent without depression (0), absent with depressed area (1), present (2)

Tibiae with short denticle on outer side at apex (43): absent (0), present (1)

Mesepisternum

- (44) *Density of punctures on lateral surface*: scattered (0), dense (1)
- (45)* *Size of punctures on lateral surface*: small and fine (0), medium-sized (1), coarse but puncture margins not strongly demarcated (2), coarse and puncture margins strongly demarcated (3)
- (46) *Density of punctures on posterolateral area near mesocoxa*: absent (0), scattered (1), dense (2)

(47) *Hypoepimeral area*: largely impunctate (0), densely punctate (1)

Scrobal area (48)*: with small impunctate area, otherwise densely punctate (0), with noticeable impunctate area (1), with large impunctate area (2)

Shape of projection on axilla (49): rounded (0), pointed (1)

Scutellum

(50) *Density of punctures*: absent or with few punctures (0), partially densely punctate (1), densely punctate throughout (2)

(51)* *Size of punctures*: absent (0), small and fine (1), medium-sized (2), coarse (3)

Metanotum

(52) *Density of punctures*: absent or with few punctures (0), densely punctate throughout (1)

(53)* *Size of punctures*: absent (0), small and fine (1), coarse and large (2)

Size of punctures on metepisternum (54)*: absent (0), small and fine (1), medium-sized (2), coarse and large (3)

Propodeum

(55) *Surface of propodeal triangle*: coriaceo-reticulate (0), strongly reticulate (1), densely punctate with fine punctures (2)

(56)* *Size of punctures on lateral area of propodeum*: absent (0), small and fine (1), medium-sized (2), coarse and large (3)

(57) *Slope of posterior portion of propodeum*: slightly declivous (0), steep declivity (1)

Female metasomal segments

(58) *Density of punctures on T1*: absent (0), sparsely punctate (1), densely punctate (2)

(59)* *Size of punctures on T1*: absent (0), small and fine (1), coarse (2)

(60) *Density of punctures on other terga*: sparsely punctate (0), densely punctate (1)

(61)* *Size of punctures on other terga*: small and fine (0), coarse (1)

(62)* *Size of punctures on postgradular areas of sterna*: small and fine (0), medium-sized (1), coarse (2)

Male sternum 6

(63) *Structure on subapical depression*: V-shape ridge (0), submedian tooth on each side (1), bilobed process with submedian tooth (2), no structure (3)

- (64) *Shape of submedian tooth*: absent (0), more or less cone shape or spine-like (1), rounded and flat (2), rectangular (3)
- (65) *Length of submedian tooth*: absent (0), short and medium (1), long (2)
- (66) *Apical lobe*: not prominent (0), prominent (1), absent (2)
- (67) *Median tooth*: absent (0), one (1), two (2)
- (68) *Lateral margin of S6*: without tooth (0), with tooth (1)

Male tergum 7

- (69) *Apex of T7*: pointed (0), triangular but not pointed (1), truncate (2), emarginate (3)
- (70) *Emargination on T7*: absent (0), present (1)
- (71) *Lateral angle of T7*: obtusely angular (0), right angular (1), acutely angular (2)
- (72) *Lateral area connecting apex and lateral angle*: straight (0), concave (1), rounded (2)

Male Genitalic structure

- (73) *Distal part of gonocoxite*: slightly narrowed (0), broad (1), narrow and rod-like (2), rounded or acute (3)
- (74) *Inner margin of gonocoxite*: rounded (0), angulated (1), straight (2)
- (75) *Tuft of hair at the distal part of gonocoxite*: absent (0), present (1)

Marking on clypeus

- (76) *Color of marking*: yellow (0), ivory white (1)
- (77) *Upper lobe of marking*: absent (0), small and narrow, at most reaching half of clypeal length (1), well-developed, reaching over half of clypeal length (2)
- (78) *Median incision of upper lobe of marking*: absent or small (0), deep (1)
- (79) *Lateral arm of marking*: absent (0), reduced, sometimes medially constricted (1), well-developed (2)

Marking on labrum (80): absent or vague (0), small (1), large, enclosing three small black spots (2)

Marking on mandible (81): absent or vague (0), present (1)

Supraclypeal spot (82)*: absent (0), small and narrowed (1), well-developed (2)

Frontal spots (83)*: absent or small and vague (0), narrowed (1), large and oval convergent (2), transverse (3)

Marking on paraocular area

(84) *Pattern of marking*: absent (0), widened from top to bottom (1), linear (2), linear with lower part bent inward (hook-like) (3), divided into two small spots (4)

(85)* *Above lower margin of antennal fossa*: absent (0), present (1)

Genal marking (86): absent (0), short, extending no more than half of eye length (1), long, extending from two thirds to entire eye length (2)

Marking on antennal scape

(87) *Marking on base of antennal scape*: absent or vague (0), present (1)

(88) *Marking on apex of antennal scape*: absent or vague (0), present (1)

Marking on pronotum

(89) *Marking on dorsal area of pronotum*: absent (0), present and unbroken (1), present and interrupted medially (2)

(90)* *Marking on pronotal lobe*: absent or vague (0), present, yellow (1), present, ivory white (2)

(91) *Dorsal marking connected to pronotal lobe marking*: yes (0), no (1)

Yellow spot behind pronotal lobe (92): absent or small or vague (0), present (1)

Longitudinal marking on scutum

(93) *Outer lines*: absent (0), present (1)

(94) *Inner lines*: absent (0), present (1)

Marking on axilla (95): absent or vague (0), present (1)

Marking on tegula (96)*: absent or vague (0), present (1)

Marking on scutellum (97)*: absent (0), one or two small spots (1), triangular (2), rectangular, narrowed posteriorly (trapezoid) (3), rectangular shape marking (4)

Marking on metanotum (98): absent or vague (0), present (1)

Marking on pro- and mesotrochanter

(99)* *Protrochanter*: absent or vague (0), present (1)

(100)* *Mesotrochanter*: absent or vague (0), present (1)

Marking on profemur

(101) *Spot on outer side*: absent or vague (0), present (1)

(102) *Spot on inner side*: absent or small (0), present (1)

Marking on protibia and mesotibia

- (103) *Marking on protibia*: extending more or less than half of tibia length (0), extending more than half to entire tibia length (1)
- (104). *Color of marking on protibia*: yellow (0), ivory white (1)
- (105) *Marking on mesotibia*: absent or only at base (0), extending more or less half of tibial length (1), extending more than half to entire tibial length (2)

Marking on metatibia (106)*: absent or only at base (0), extending more or less half of tibial length (1), extending more than half to entire tibial length (2)

Color of marking on protibia (107): yellow (0), ivory white (1)

Color of tarsi (excluding metabasitarsus) (108)*: dark brown to black (0), ferruginous to dark yellow (1), bright yellow (2)

Color of metabasitarsus (109)*: dark brown to black (0), ferruginous to dark yellow (1), bright yellow (2)

Metasomal bands

- (110) *T1 band*: absent or vague (0), not enclosing two small spots (1), enclosing or almost enclosing two small black spots (2)
- (111) *T2 band*: absent or vague (0), unbroken or slightly interrupted medially (1), broadly interrupted medially (2)
- (112) *T3 band*: absent or vague (0), unbroken or slightly interrupted medially (1), broadly interrupted medially (2)
- (113)* *T6 band* in female: absent (0), present (1)
- (114)* *T7 band* in male: absent (0), present (1)

- (115) *Declivity of anterior part of T1*: steep slope (0), nearly flat (1), flat with median groove (2)
- (116) *Length of hairs on metasomal terga*: short (0), medium (1), long (2)
- (117) *Color on postgradular area on T4 and T5 in female*: color not changed from pregradular area (0), color changed from pregradular area (1)
- (118) *Color of lateral area of propodeum*: color not differs from propodeal triangle (0), color differs from propodeal triangle (1)
- (119) *Color of pregradular area*: black or metallic green (0), yellow (1)
- (120) *Color of sterna*: black or metallic green (0), yellow (1)

APPENDIX III

Geographical Distributions of Ceratinidia species (+: Present, -: Absent, ?: Uncertain)

| Species | Afghanistan | Northern India & Nepal | Southern India | Thailand | Laos | Cambodia | Vietnam | Taiwan | Eastern China |
|--------------------------------|-------------|---------------------------|-------------------|----------|------|----------|---------|--------|------------------|
| <i>Ceratina bicuneata</i> | - | - | - | - | - | - | - | - | - |
| <i>Ceratina tropica</i> | - | - | - | - | - | - | - | - | - |
| <i>Ceratina carinifrons</i> | - | - | - | - | - | - | - | - | - |
| <i>Ceratina rugifrons</i> | - | - | - | - | - | - | - | - | - |
| <i>Ceratina similima</i> | - | + | + | - | - | - | - | - | - |
| <i>Ceratina coptica</i> | - | - | + | - | - | - | - | + | + |
| <i>Ceratina taiwanensis</i> | - | - | - | - | - | - | - | - | - |
| <i>Ceratina okinawana</i> | - | - | - | - | - | - | - | - | - |
| <i>Ceratina lepida</i> | - | - | - | - | - | - | - | - | - |
| <i>Ceratina bryanti</i> | - | - | - | + | - | - | - | - | - |
| <i>Ceratina sutepensis</i> | - | - | - | + | - | - | - | - | - |
| <i>Ceratina japonica</i> | - | - | - | - | - | - | - | - | - |
| <i>Ceratina flavipes</i> | - | - | - | - | - | - | - | - | - |
| <i>Ceratina maai</i> | - | - | - | - | - | - | - | - | + |
| <i>Ceratina lejuensis</i> | - | - | - | - | - | - | - | - | - |
| <i>Ceratina litorea</i> | - | - | - | - | - | - | - | - | - |
| <i>Ceratina accusator</i> | - | - | - | + | - | - | - | - | - |
| <i>Ceratina pulchripes</i> | - | - | - | - | - | - | - | + | - |
| <i>Ceratina chiangmaiensis</i> | - | - | - | + | - | - | - | - | - |
| <i>Ceratina takasago</i> | - | - | - | - | - | - | - | + | - |
| <i>Ceratina alpicola</i> | - | - | - | - | - | - | - | + | - |
| <i>Ceratina moderata</i> | - | + | - | - | - | - | - | - | - |
| <i>Ceratina demotica</i> | - | + | - | - | - | - | - | - | - |
| <i>Ceratina hieratica</i> | + | - | - | - | - | - | - | - | - |
| <i>Ceratina rugosohypeata</i> | - | - | + | - | - | - | - | - | - |
| <i>Ceratina tieftmcki</i> | - | - | - | + | + | + | - | - | - |
| <i>Ceratina collusor</i> | - | - | - | + | + | - | - | - | - |
| <i>Ceratina nigrolateralis</i> | - | - | - | + | + | - | + | - | - |
| <i>Ceratina compacta</i> | - | - | - | ? | - | - | - | - | - |
| <i>Ceratina jacobsoni</i> | - | - | - | - | ? | - | - | - | - |
| <i>Ceratina cognata</i> | - | - | - | + | + | - | - | - | - |
| <i>Ceratina punicigena</i> | - | - | - | - | - | - | - | - | - |
| <i>Ceratina interrupta</i> | - | - | - | - | - | - | - | - | - |
| <i>Ceratina malukuensis</i> | - | - | - | - | - | - | - | - | - |
| <i>Ceratina papuana</i> | - | - | - | - | - | - | - | - | - |

Geographical Distributions of Ceratinidia species (continued...)

| Species | Korea Peninsula | Ryukyu Island, Japan | Japan | Primorskyi, Russia | Palawan Island, Philippines | Philippines | Malay Peninsula |
|--------------------------------|-----------------|----------------------|-------|--------------------|-----------------------------|-------------|-----------------|
| <i>Ceratina bicuneata</i> | - | - | - | - | - | + | - |
| <i>Ceratina tropica</i> | - | - | - | - | - | + | - |
| <i>Ceratina carinifrons</i> | - | - | - | - | - | - | - |
| <i>Ceratina rugifrons</i> | - | - | - | - | - | + | - |
| <i>Ceratina similima</i> | - | - | - | - | - | - | - |
| <i>Ceratina copticca</i> | - | - | - | - | - | - | - |
| <i>Ceratina taiwanensis</i> | - | - | - | - | - | - | - |
| <i>Ceratina okinawana</i> | - | + | - | - | - | - | - |
| <i>Ceratina leptida</i> | - | - | - | - | - | - | - |
| <i>Ceratina bryanti</i> | - | - | - | - | - | - | + |
| <i>Ceratina suepensis</i> | - | - | - | - | - | - | - |
| <i>Ceratina japonica</i> | + | - | + | - | - | - | - |
| <i>Ceratina flavipes</i> | + | - | + | + | - | - | - |
| <i>Ceratina maai</i> | - | - | - | - | - | - | - |
| <i>Ceratina jejuensis</i> | + | - | - | - | - | - | - |
| <i>Ceratina litoraria</i> | - | - | - | - | - | - | - |
| <i>Ceratina accusator</i> | - | - | - | - | - | - | + |
| <i>Ceratina pulchripes</i> | - | - | - | - | - | - | - |
| <i>Ceratina chiangmaiensis</i> | - | - | - | - | - | - | - |
| <i>Ceratina takasagona</i> | - | - | - | - | - | - | - |
| <i>Ceratina alpicola</i> | - | - | - | - | - | - | - |
| <i>Ceratina moderata</i> | - | - | - | - | - | - | - |
| <i>Ceratina demoitica</i> | - | - | - | - | - | - | - |
| <i>Ceratina hieratica</i> | - | - | - | - | - | - | - |
| <i>Ceratina rigosochypeata</i> | - | - | - | - | + | - | + |
| <i>Ceratina lieffincki</i> | - | - | - | - | + | - | + |
| <i>Ceratina collusor</i> | + | - | - | - | - | - | + |
| <i>Ceratina nigrolateralis</i> | - | - | - | - | - | + | - |
| <i>Ceratina compacta</i> | - | - | - | - | - | - | - |
| <i>Ceratina jacobsoni</i> | - | - | - | - | - | - | - |
| <i>Ceratina cognata</i> | - | - | - | - | - | - | + |
| <i>Ceratina punctigena</i> | - | - | - | - | - | - | - |
| <i>Ceratina interrupta</i> | - | - | - | - | - | - | - |
| <i>Ceratina malukuensis</i> | - | - | - | - | - | - | - |
| <i>Ceratina papuana</i> | - | - | - | - | - | - | - |

Geographical Distributions of Ceratinidia species (continued...)

| Species | Sumatra | Java | Borneo | Bali | Flores | Sulawesi | Maluku Islands | New Guinea |
|--------------------------------|---------|------|--------|------|--------|----------|----------------|------------|
| <i>Ceratina bicuneata</i> | - | - | - | - | - | - | - | - |
| <i>Ceratina tropica</i> | - | - | - | - | - | - | - | - |
| <i>Ceratina carinifrons</i> | - | - | - | - | - | + | - | - |
| <i>Ceratina rugifrons</i> | - | - | - | - | - | + | - | - |
| <i>Ceratina similima</i> | - | - | - | - | - | - | - | - |
| <i>Ceratina copitica</i> | - | - | - | - | - | - | - | - |
| <i>Ceratina taiwanensis</i> | - | - | - | - | - | - | - | - |
| <i>Ceratina okinawana</i> | - | - | - | - | - | - | - | - |
| <i>Ceratina lepida</i> | - | - | - | - | - | - | - | - |
| <i>Ceratina bryanti</i> | + | + | - | + | - | - | - | - |
| <i>Ceratina sutepensis</i> | - | - | - | - | - | - | - | - |
| <i>Ceratina japonica</i> | - | - | - | - | - | - | - | - |
| <i>Ceratina flavipes</i> | - | - | - | - | - | - | - | - |
| <i>Ceratina maai</i> | - | - | - | - | - | - | - | - |
| <i>Ceratina jejuensis</i> | - | - | - | - | - | - | - | - |
| <i>Ceratina lioraria</i> | + | + | - | - | + | - | - | - |
| <i>Ceratina accusator</i> | + | + | + | - | - | - | - | - |
| <i>Ceratina pulchripes</i> | - | - | - | - | - | - | - | - |
| <i>Ceratina chiangmatensis</i> | - | - | - | - | - | - | - | - |
| <i>Ceratina takasagana</i> | - | - | - | - | - | - | - | - |
| <i>Ceratina alpicola</i> | - | - | - | - | - | - | - | - |
| <i>Ceratina moderata</i> | - | - | - | - | - | - | - | - |
| <i>Ceratina demotica</i> | - | - | - | - | - | - | - | - |
| <i>Ceratina hieratica</i> | - | - | - | - | - | - | - | - |
| <i>Ceratina rugosoclypeata</i> | - | - | - | - | - | - | - | - |
| <i>Ceratina lieftincki</i> | - | + | - | - | - | - | - | - |
| <i>Ceratina collisor</i> | - | + | - | - | - | - | - | - |
| <i>Ceratina nigrolateralis</i> | + | + | + | + | - | - | - | - |
| <i>Ceratina compacta</i> | - | - | - | - | - | - | - | - |
| <i>Ceratina jacobsoni</i> | - | + | - | - | - | - | - | - |
| <i>Ceratina cognata</i> | + | + | - | - | - | + | - | - |
| <i>Ceratina punctigena</i> | - | + | - | - | - | - | - | - |
| <i>Ceratina interrapia</i> | - | - | - | - | - | - | + | - |
| <i>Ceratina malukuensis</i> | - | - | - | - | - | - | + | - |
| <i>Ceratina papuana</i> | - | - | - | - | - | - | - | + |

Note: The most updated revision on *Xanthoceratina* and *Looceratina* is from van der Vecht (1952), which indicated that the two groups are present mostly in the Southeast Asia region. *Xanthoceratina* (including more or less 7 species) is found on Borneo, Burma, Java, the Malay Peninsula, Palawan, the Philippines, Sumatra, and Sri Lanka (?). *Looceratina* (including more or less 6 species) is found on Bali, Borneo, Java, India (?), the Malay Peninsula, the Philippines, Singapore, Sulawesi, Sumatra, Taiwan (?).