



Universiteit
Leiden
The Netherlands

The role of FIS in trans activation of stable RNA operons of *E. coli*

Nilsson, L.; Vanet, A.; Vijgenboom, E.; Bosch, L.

Citation

Nilsson, L., Vanet, A., Vijgenboom, E., & Bosch, L. (1990). The role of FIS in trans activation of stable RNA operons of *E. coli*. *Embo Journal*, 9(3), 727-734.

doi:10.1002/j.1460-2075.1990.tb08166.x

Version: Publisher's Version

License: [Licensed under Article 25fa Copyright Act/Law \(Amendment Taverne\)](#)

Downloaded from: <https://hdl.handle.net/1887/3239434>

Note: To cite this publication please use the final published version (if applicable).

The role of FIS in *trans* activation of stable RNA operons of *E.coli*

Lars Nilsson¹, Anne Vanet, Erik Vijgenboom and Leendert Bosch

Department of Biochemistry, Leiden University, Gorlaeus Laboratories, 2333 AL Leiden, The Netherlands

¹Present address: Department of Cell Biology, The University of Stockholm, S-106 91 Stockholm, Sweden

Communicated by L. Bosch

The *thrU(tufB)* operon of *Escherichia coli* is endowed with a *cis*-acting region upstream of the promoter, designated UAS for Upstream Activator Sequence. A protein fraction has been isolated that binds specifically to DNA fragments of the UAS, thus forming three protein–DNA complexes corresponding to three binding sites on the UAS. It stimulates *in vitro* transcription of the operon by facilitating the binding of the RNA polymerase to the promoter. All three protein–DNA complexes contain one and the same protein. Dissociation constants for the three complexes have been determined, the lowest being in the sub-nanomolar range. The protein also binds to the UAS of the *tyrT* operon and to the UAS upstream of the P1 promoter of the *rnnB* operon, suggesting that transcription of the three operons, if not of more stable RNA operons, is activated by a common *trans* activator. We demonstrate that the *E.coli* protein FIS (Factor for Inversion Stimulation) also binds to the UAS of the *thrU(tufB)* operon forming three protein–DNA complexes. A burst of UAS- and FIS-dependent promoter activity is observed after reinitiation of growth of stationary cultures in fresh medium.

Key words: DNA binding protein /FIS/stable RNA/transcription activation/upstream activating sequence

Introduction

The bacterial genes specifying rRNA and tRNA are highly expressed during exponential growth. Together their gene products account for ~97% of the total RNA content of the cell (Lamond, 1985). The expression is coordinately regulated by a network of control mechanisms. During recent years a number of these mechanisms have been studied in detail, such as growth rate-dependent regulation, ribosomal feedback and stringent control (for reviews, see Nomura *et al.*, 1984; Lindahl and Zengel, 1986). According to current views they act through repression. Their DNA determinants are located between position –50 and the start of transcription (Duester *et al.*, 1982; Gourse *et al.*, 1986; Lamond and Travers, 1985). Here we describe a mechanism that acts through activation, with DNA determinants located between positions –130 and –48. Although transcription initiation at the stable RNA promoters is very efficient, these promoters do not optimally fit the consensus –10 and –35

sequence. Deletion studies revealed that the high expression level of some of these genes is due to a *cis*-acting sequence upstream of the promoter, elimination of which results in a 10- to 15-fold drop in transcription. Such an upstream activating sequence (UAS) has been found upstream of the tRNA operons: *tyrT* (Lamond and Travers, 1983), *leuV* (Bauer *et al.*, 1988) and *thrU(tufB)* (van Delft *et al.*, 1987a), and of the P1 promoter of the rRNA operon *rnnB* (Gourse *et al.*, 1986) (Figure 1).

We have isolated a protein fraction that binds specifically to the UAS of the *thrU(tufB)* operon. The coincidence of the nucleotide sequence involved in the protein binding *in vitro* and the sequence acting in *cis* on transcription *in vivo*, strongly suggests that the protein/DNA interaction results in *trans* activation of the operon (Vijgenboom *et al.*, 1988). We show such a *trans* activation of *in vitro* transcription with plasmid-borne *thrU(tufB)*.

Although the UASs of the stable RNA operons mentioned above show a low degree of sequence homology (Travers, 1984) they show some common features. They are AT-rich and display bending of the DNA helix (Gourse *et al.*, 1986; Drew and Travers, 1984). Since the expression of these operons is highly coordinated *in vivo*, the question may be raised whether the UASs bind a common activator protein. We show that DNA fragments derived from the UASs of the *tyrT*, *thrU(tufB)* and *rnnB* compete *in vitro* for binding to the same protein when the latter is present in limiting amounts. Both *in vivo* and *in vitro* data suggest this protein to be FIS (Factor for Inversion Stimulation) (described by Kahmann *et al.*, 1985; Johnson and Simon, 1985).

These data reveal a novel control mechanism for regulating the expression of the stable RNA operons investigated here. It becomes operative under non-steady state conditions when an increase in the level of stable RNA is required, e.g. during outgrowth from the stationary phase into exponential growth. The possibility may be envisaged that more stable operons are submitted to this activation mechanism. The mechanism plays an important role in the synthesis of the translational machinery and in the regulation of cell growth.

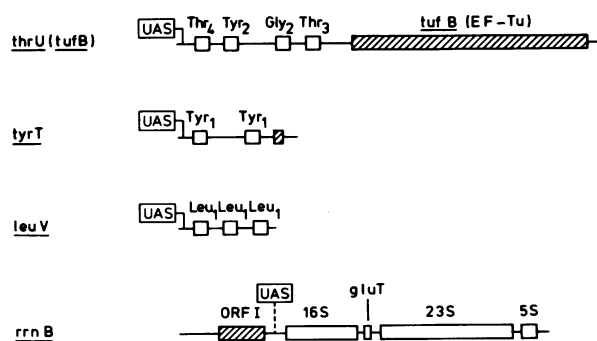

Fig. 1. Four stable RNA operons with upstream activating sequences (not drawn to scale).

Results

Protein binding to the UAS of the *thrU(tufB)* operon

Previously (Vijgenboom *et al.*, 1988) we have shown that an elongation factor-Tu (EF-Tu).GDP preparation, isolated by affinity chromatography on a GDP-Sepharose column, contains one or more proteins that bind(s) specifically to the UAS of the *thrU(tufB)* operon *in vitro*. When sufficient protein was present up to three protein-DNA complexes were formed, as became evident by the electrophoretic retardation of the end-labeled DNA fragments derived from the UAS (compare Figure 2A). Do all three complexes contain the same protein(s)? This question could be answered in the affirmative by adding increasing amounts of DNA fragment to a fixed amount of protein. As can be seen in Figure 2B, such an increase leads to enhanced formation of all three complexes in the lower concentration range of DNA fragments. Beyond a certain DNA concentration, however, complex 1 and 2 successfully compete with complex 3 for protein binding. This leads to disappearance of complex 3 and to further increases of complexes 1 and 2. At still higher DNA concentrations complex 2 also starts to decline in favour of complex 1 formation. These data are best explained by assuming that one and the same protein is present in all three complexes but that the number of these protein molecules differs from complex to complex.

Binding sites on the UAS and dissociation constants of the three protein-DNA complexes

Incubation of the DNA fragment with increasing amounts of the protein preparation results in the successive formation of complex 1, 2 and 3. At the lower protein/DNA ratios, only complex 1 is formed but raising this ratio leads to the formation of complex 2 and 3 and disappearance of complex

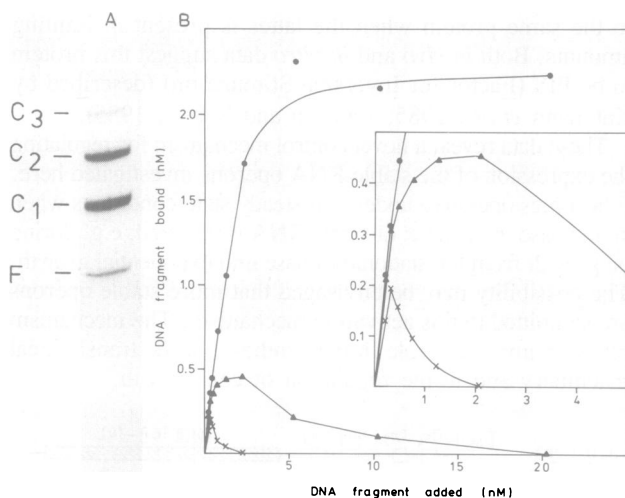

Fig. 2. (A) Protein binding to the UAS fragment (position -176 to +109) of the *thrU(tufB)* operon. 1 μ M of the EF-Tu.GDP preparation was incubated with the end-labeled UAS fragment and the complexes formed were analysed as described in Materials and methods. The four bands correspond to free DNA and complexes 1-3. (B) Titration of the amount of protein bound in complex 1. Increasing amounts of the UAS fragment (-176 to +109) of the *thrU(tufB)* operon were incubated with a fixed amount of the EF-Tu.GDP preparation (3.4 μ M). The complexes formed were analysed with the electrophoretic retardation technique as described in Materials and methods and quantified by densitometric tracing. (●) DNA bound in complexes 1+2+3. (▲) DNA bound in complexes 2+3 and (X) DNA bound in complex 3. The initial parts of the curves are enlarged in the insert.

1. Apparently, complex 1 containing at least one bound protein molecule is converted to complex 2 and complex 2 is converted to 3 upon binding of additional protein molecules, suggesting the presence of three binding sites on the UAS. Footprinting with DNase I tentatively localized these sites in two regions: between positions -48 and -81 and between -118 and -131 (Vijgenboom, 1989), but additional footprintings with other techniques are necessary to define the sites more accurately.

Three different K_d values could be determined for the three protein-DNA complexes by plotting free/occupied binding sites versus the reciprocal of the free DNA binding protein concentration (see also legend to Table I). This gives a straight line with a slope identical to the K_d for each complex. As can be seen in Table I, a K_d in the sub-nanomolar range was found for C1, the K_d 's of complex 2 and 3 being approximately one order of magnitude higher. Apparently, differences in affinity exist for the three sites but the protein binds with high affinity and high specificity. It may be noted that the determination of the K_d of C1 is not very accurate due to the high affinity of the protein for the DNA fragment (meaningful data can only be obtained in a limited range of reactant concentrations). K_d determinations for C2 and C3 are more reliable.

Trans activation of the *thrU(tufB)* operon *in vitro*

As mentioned in the introduction, the coincidence of the protein/DNA binding sequence and the sequence acting in *cis* on transcription *in vivo* strongly suggests that the

Table I. Dissociation constants of the three protein-DNA complexes

| | C1 | C2 | C3 |
|------------|------|-----|-----|
| K_d (nM) | 0.06 | 0.7 | 2.0 |

The data from Figure 3 were used to calculate the K_d of the three complexes as indicated in the text. Total DNA binding protein concentration was determined from the concentration of DNA fragment bound at saturating concentrations of the fragment (Figure 2b). This enabled calculation of the concentration of free DNA binding protein under the various conditions.

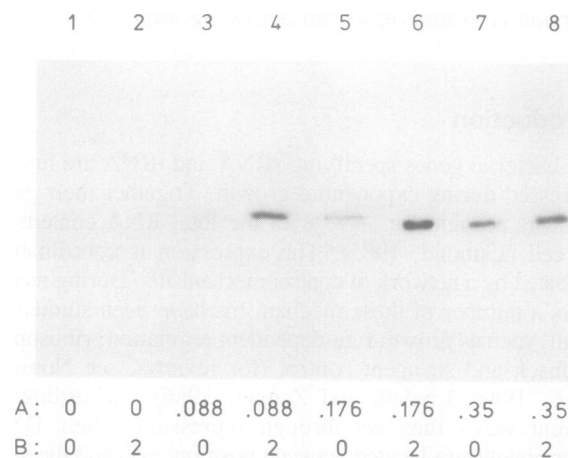

Fig. 3. Trans activation of *in vitro* transcription of plasmid-borne *thrU(tufB)*. The *in vitro* transcription was as described in Materials and methods. Supercoiled plasmid containing a fragment of the *thrU(tufB)* operon extending from position -176 to +562 was incubated with *E. coli* RNA polymerase and the EF-Tu.GDP preparation. For further details see text. A: amount of RNA polymerase added (in units). B: amount of EF-Tu.GDP preparation added (in μ g).

protein/DNA interaction results in *trans* activation of the operon. Accordingly, *in vitro* transcription of the plasmid-borne *thrU(tufB)* operon is stimulated by the addition of the protein as is illustrated in Figure 3. Transcripts formed under these conditions were identified by hybridization with a labeled DNA probe (+26 to +109) and S1 nuclease treatment of the hybrids formed. The procedure determines the synthesis of 5'-terminal transcript fragments of ~100 hundred nucleotides. As is evident from Figure 3, no transcription occurs in the absence of RNA polymerase (lane 1) or in the presence of solely the DNA binding protein (lane 2). The latter control shows that the DNA binding protein does not contain any RNA polymerase. Stimulation of transcription is most clearly demonstrated at low RNA polymerase concentrations (lanes 3 and 4). At higher concentrations the stimulatory effect decreases (lanes 5 and 6) and ultimately vanishes completely (lanes 7 and 8). Apparently, binding of the *trans* activating protein to the UAS facilitates the binding of the polymerase to the promoter, thereby stimulating transcription initiation.

Protein binding is not restricted to the UAS of the *thrU(tufB)* operon

Despite the relatively low degree of sequence homology of the UASs of the tRNA operons and the UAS upstream of

P1 of *rrnB*, these elements show some common features, such as AT-rich regions and a bent or kinked DNA helix. Moreover, the UASs of Figure 1 are all located at approximately the same distance from the promoter and the stimulatory effects on transcription are approximately the same. We therefore addressed the question whether these UASs are the target of a common DNA binding protein. To this aim we studied the interaction of the protein preparation with fragments of different lengths derived from the UASs of the *tyrT* and the *rrnB* operons.

The UAS of the *tyrT* operon has been mapped by Travers *et al.* (Lamond and Travers, 1983) between positions -98 and -40. As is evident from Figure 4, the UAS fragment comprising positions -98 to +50 forms two protein-DNA complexes. Fragments lacking the sequence -98 to -76 are unable to bind the protein. This clearly demonstrates that protein binding occurs specifically to the *tyrT* UAS. An additional binding site more remote from the RNA polymerase binding site is not excluded. It is noteworthy that one of the binding sites on the UAS of the *thrU(tufB)* operons was mapped in the region around position -120 (Vijgenboom, 1989). A third binding site on the UAS of the *tyrT* operon, upstream of position -98 therefore seems possible and may have been missed here due to the sizes of the DNA fragments available for study.

The protein also binds to the UAS upstream of the P1 promoter of the *rrnB* operon. Nomura and coworkers mapped the UAS of this operon between positions -88 and -50 (Gourse *et al.*, 1986). Incubation of the fragment -595 to +90 with the EF-Tu.GDP preparation resulted in the formation of up to five protein-DNA complexes (Figure 5). Formation of complexes 4 and 5 is only detectable, however, at very high protein concentrations. After curtailing the fragment from both sides to positions -150 and +50, three complexes were still apparent. Further reduction to a fragment from -46 to +50 resulted in a total loss of binding activity, illustrating that binding occurs specifically to the UAS upstream of P1 of this operon.

The UASs of the *thrU(tufB)*, the *tyrT* and the *rrnB* operons bind the same protein

Since the protein preparation used above was not homogeneous, it was necessary to exclude that three different proteins, present in the preparation, were binding to the three UASs. Competition experiments were therefore set up between DNA fragments from the UASs of the three stable

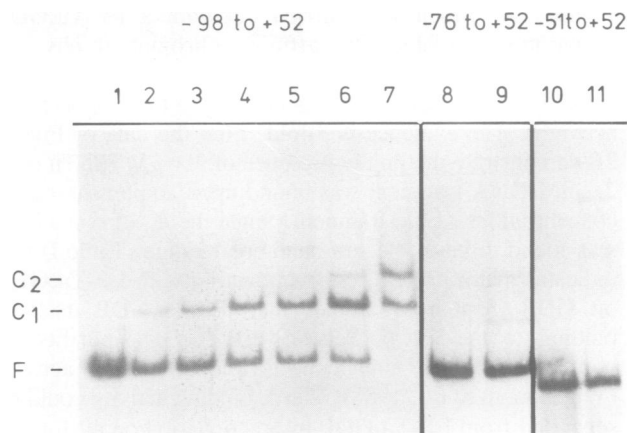

Fig. 4. Binding of FIS to the UAS of the *tyrT* operon. UAS fragments of the *tyrT* operon (length as indicated) were incubated with the following amounts of the EF-Tu.GDP preparation in lanes 1-11: 0 nM; 300 nM; 600 nM; 1.5 μ M; 2.1 μ M; 3 μ M; 6 μ M; 0 nM; 3 μ M; 0 nM; 3 μ M, respectively.

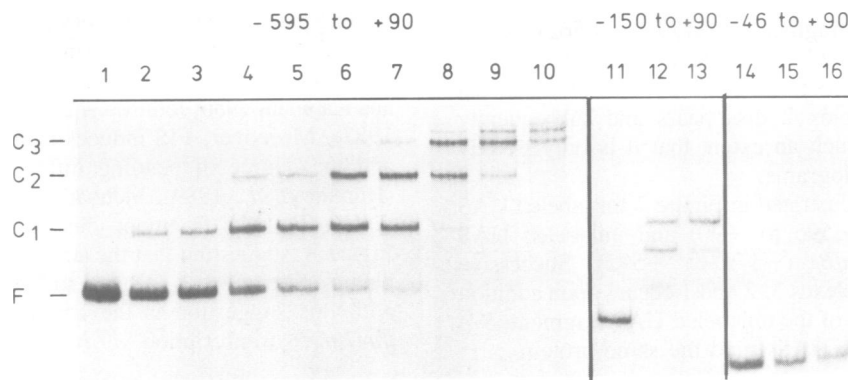

Fig. 5. Binding of FIS to the UAS of the *rrnB* operon. UAS fragments of the *rrnB* operon (length as indicated) were incubated with the following amounts of the EF-Tu.GDP preparation in lanes 1-16: 0 nM; 30 nM; 60 nM; 150 nM; 210 nM; 300 nM; 600 nM; 1.5 μ M; 2.1 μ M; 3 μ M; 0 nM; 1.5 μ M; 3 μ M; 0 nM; 1.5 μ M; 3 μ M, respectively.

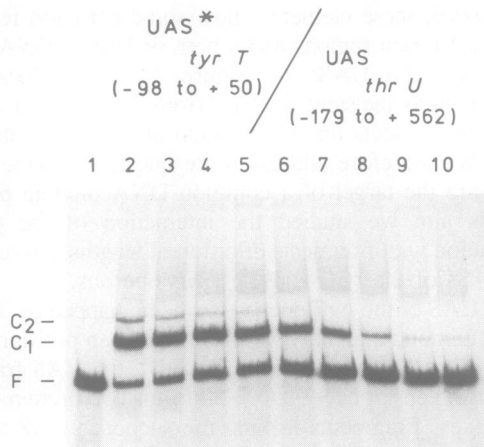

Fig. 6. Competition between UAS fragments of the *tyrT* and the *thrU(tufB)* operons for FIS binding. 0.3 nM ^{32}P -labelled UAS fragment of *tyrT* was incubated with 3 μM of the EF-Tu.GDP preparation and the following amounts of unlabeled UAS fragments of the *thrU(tufB)* (fragment lengths as indicated) in lanes 2–10: 0 nM; 0.35 nM; 0.7 nM; 1.75 nM; 3.5 nM; 7 nM; 17.5 nM; 35 nM, 70 nM, respectively. Lane 1: no protein added.

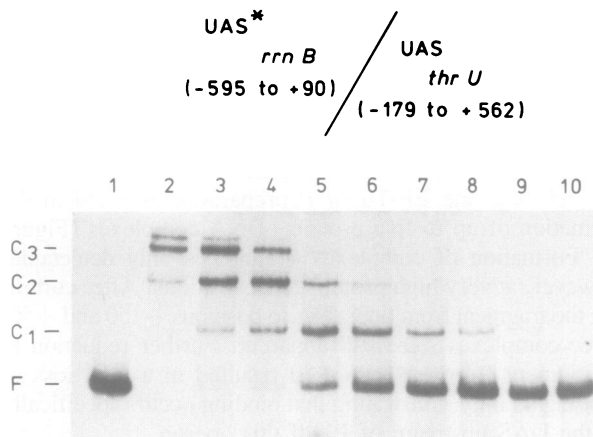

Fig. 7. Competition between UAS fragments of the *rrnB* and the *thrU(tufB)* operons for FIS binding. 0.3 nM ^{32}P -labelled UAS fragment of *rrnB* was incubated with 1.5 μM of the EF-Tu.GDP preparation and the following amounts of unlabeled UAS fragments of the *thrU(tufB)* (fragment lengths as indicated) in lanes 2–10: 0 nM; 0.35 nM; 0.7 nM; 1.75 nM; 3.5 nM; 7 nM; 17.5 nM; 35 nM; 70 nM, respectively. Lane 1: no protein added.

RNA operons. Figure 6 shows such a competition experiment for labeled fragments (–98 to +50) of the *tyrT* UAS and unlabeled fragments (–179 to +562) of the *thrU(tufB)* UAS. Labeled fragments are competed out for protein binding upon increasing the amount of unlabeled fragments: first complex 2 disappears and subsequently complex 1 drops to such an extent that it is only weakly visible in the autoradiograms.

Similar results are illustrated in Figure 7 for labeled UAS fragments of *rrnB* (–595 to +90) and unlabeled UAS fragments of *thrU(tufB)* (–179 to +562). Successive disappearance of complexes 3, 2 and 1 occurs upon addition of increasing amounts of the unlabeled UAS fragment. We conclude that all three UASs bind the same protein.

The nature of the DNA binding protein

What is the nature of this DNA binding protein? Earlier experiments (Vijgenboom *et al.*, 1988) suggested that this

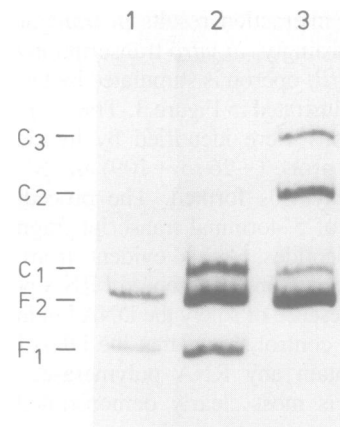

Fig. 8. FIS binding to the UAS fragment (position –176 to +109) of the *thrU(tufB)* operon. Purified FIS was incubated with two end-labeled DNA fragments (1 nM of each). One (F1) contains the UAS sequence (–197 to +109) and the other (F2) is from the tRNA gene region (+109 to +562). The latter fragment functions as an internal control for the specificity. The complexes formed were analyzed as described in Materials and methods. Lane 1 the two DNA fragments incubated in the absence of FIS. Lane 2, 1 ng FIS added. Lane 3, 2 ng FIS.

protein is identical to EF-Tu. In line with this suggestion is the binding to the UAS of the operon as illustrated in Figure 2A, which was carried out with a EF-Tu.GDP preparation isolated by affinity chromatography on GDP–Sephadex.

EF-Tu by itself, however, is not able to function as *trans* activator. The evidence is 3-fold. First the data of Figure 2B demonstrate that in the presence of 3.1 μM EF-Tu only 2.2 nM DNA fragment was bound upon adding saturating concentrations of the fragment. Since the K_d of complex 1 was found to be in the sub-nanomolar range (Table I) this indicates that a protein, co-fractionating with EF-Tu.GDP on GDP–Sephadex, rather than EF-Tu.GDP itself is binding to the DNA. Second, EF-Tu.GDP purified to homogeneity was found to be devoid of binding activity (Vijgenboom *et al.*, 1988). Third, binding activity could be separated from EF-Tu.GDP by fractionation on a Mono Q column. Protein, binding to the DNA fragment, emerged from the column at <100 mM KCl, prior to the main EF-Tu peak emerging at 600 mM KCl (data not shown). Its relative molecular mass was estimated as between 10 and 15 kd.

The size of the separated DNA binding protein, its DNA binding pattern and the number of protein–DNA complexes formed, appeared to be very similar to that of FIS, a protein that stimulates the inversion of various DNA segments (Koch and Kahman, 1986; Johnson *et al.*, 1986; Haffter and Bickle, 1987). Moreover, FIS induces bending of enhancer DNA and the degree of bending influences enhancer function (Hübner *et al.*, 1989). Incubation of purified FIS with the *thrU(tufB)* UAS fragment yielded the result illustrated in Figure 8, suggesting that the active component in our DNA binding preparation is identical to FIS, indeed. In accordance with this suggestion is the stimulatory effect of FIS on *thrU(tufB)* transcription *in vivo* (see below).

UAS- and Fis-dependent trans activation of the thrU(tufB) operon in vivo

The data described thus far strongly suggest that transcription of the three operons most likely is controlled by a common

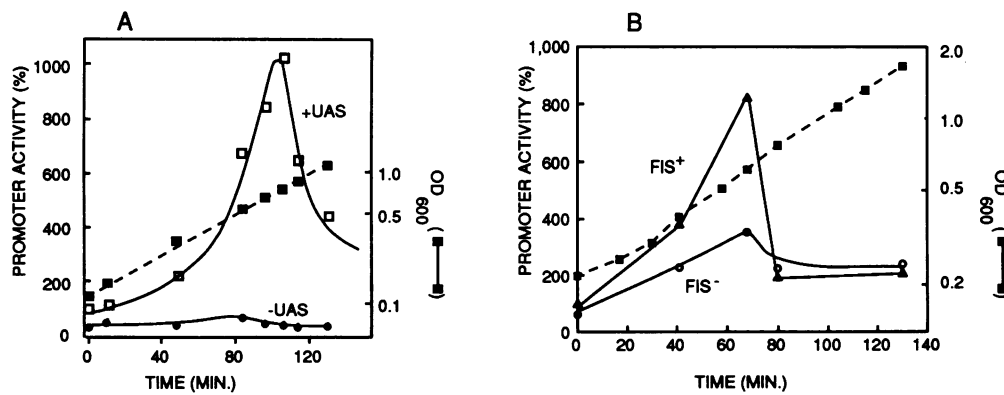

Fig. 9. Promoter activity of the plasmid-borne *thrU(tufB)* operon during the bacterial growth cycle. (A) AB 2463 cells transformed with a deletion derivative of pDS10 carrying the operon fusion *thrU(tufB):galK* were assayed for galactokinase activity as described under Materials and methods. Galactokinase activities were corrected for plasmid copy numbers. The UAS of UAS⁺ cells extends from position -176 to the promoter. UAS⁻ cells have undergone a deletion from -176 to -57 . Overnight cultures were diluted to an OD₆₀₀ of 0.1 and subsequently grown in fresh LB medium supplemented with 0.4% glucose. Promoter activity of the UAS⁺ cells of zero time was set at 100%. (B) The *E. coli* strains MC 1000 (*fis*⁺) and MC 1000-Fis767 (*fis*⁻) (see Materials and methods) were transformed with the plasmid containing the UAS. Overnight cultures were diluted to an OD₆₀₀ of 0.2 and subsequently grown in fresh LB medium without extra glucose. Promoter activity of the FIS⁺ UAS⁺ cells at zero time was set at 100%. For further details see legend to A.

trans activating mechanism, dependent on the UASs of these operons and on FIS. When does this mechanism become operative? To answer this question we fused the *thrU(tufB)* operon to the promoterless *galK* gene as described by van Delft *et al.* (1987a). The operon fusion, that puts the expression of *galK* under control of the *thrU(tufB)* promoter (McKenney *et al.*, 1981), was introduced into a *galK*-defective *E. coli* strain via a plasmid as described under Materials and methods. Figure 9A shows the galactokinase activity during growth of cells transformed with the plasmid. The galactokinase activity per cell rises rapidly in the early phase of the growth cycle to a level that exceeds the original level ~ 10 -fold. After having reached the maximum it decreases rather abruptly and levels off in the late log phase.

These data indicate that the number of transcripts also displays a rapid increase followed by a drop, although they do not account for the difference in life span of the galactose protein and the transcript which leads to an overestimate of the transcripts present at the times indicated. A better measure of the promoter activity can be obtained by plotting galactokinase increases occurring in short time intervals over the corresponding increases of cell mass and correcting these ratios for plasmid copy numbers. This procedure does not lead, however, to a conclusion differing from the present one that a burst of promoter activity of the *thrU(tufB)* operon is observed rather early in the growth cycle. The pattern is very similar to that described by Lukacovich *et al.* (1987) for the activity of the P1 and the P2 promoters of the *rrnB* operon. These authors found the number of transcripts, initiated at these promoters, to vary > 10 -fold during the growth cycle.

Interestingly, Figure 9A shows that deletion of the UAS of the *thrU(tufB)* operon virtually abolishes the peak of promoter activity. Apparently, the > 10 -fold variation in transcripts is UAS dependent and due to a variation in *trans* activation of the operon during the growth cycle.

To show that this burst in promoter activity is dependent on FIS we performed a similar experiment in a strain lacking FIS. As seen in Figure 9B, overnight cultures of *fis*⁺ and *fis*⁻ cells do not differ in galactokinase content. Upon reinitiation of growth, however, the increase of galactokinase activity in *fis*⁺ cells exceeds that in *fis*⁻ cells, clearly

indicating that *trans* activation of the *thrU(tufB)* operon is affected by the presence of FIS. That the effect of FIS is less than that of the UAS may be due to *cis* activity of the UAS in the absence of FIS but other regulatory control systems compensating for the lack of FIS may also become operative under these conditions. We are presently engaged in studying this question.

We conclude that transcription regulation by *trans* activation becomes operative under non-steady state conditions, when changes in growth rate, induced by environmental signals, create a demand for rRNA and tRNA.

Discussion

The present study has brought forward a number of new and striking aspects of stable RNA synthesis. First it reveals a novel mechanism controlling the transcription of the *thrU(tufB)* operon by *trans* activation. Evidence is presented that two other stable RNA operons: the *tyrT* and the *rrnB* operon, are submitted to the same regulatory system. In contrast to the control mechanisms described so far for stable RNA operons, such as ribosome feedback and stringent control (Nomura *et al.*, 1984; Lindahl and Zengel, 1986), this novel mechanism does not operate through repression but through stimulation of transcription initiation. Interestingly, the present data further indicate that the *E. coli* protein FIS, plays a decisive role in *trans* activation. This protein is known to stimulate the inversion of various DNA segments by binding to *cis*-acting recombinational enhancers, detected in various prokaryotic DNA inversion systems (Kahmann *et al.*, 1985; Johnson and Simon, 1985; Huber *et al.*, 1985). Up till now the phenotype of *fis*⁻ mutations was not known. Our study demonstrates that *trans* activation of the *thrU(tufB)* operon is drastically reduced in *fis*⁻ cells.

Below we discuss these features successively.

Trans activation of stable RNA operons

The experimental evidence for *trans* activation of the *thrU(tufB)* operon is based on our finding that the nucleotide sequences involved in specific protein binding *in vitro* and the sequences acting in *cis* on transcription *in vivo*, coincide (Vijgenboom *et al.*, 1988), and that *in vitro* transcription

of the plasmid-borne *thrU(tufB)* operon is stimulated by the DNA binding protein preparation, facilitating the binding of the RNA polymerase to the promoter (Figure 3).

The protein binds *in vitro* to DNA fragments derived from the UASs of all three stable RNA operons mentioned above. When the protein is present in limiting amounts the DNA fragments compete for binding. Although our investigation deals with the *tyrT*, the *thrU(tufB)* and the *rrnB* operon only, it is conceivable that the regulation of more stable RNA operons is governed by the binding of this protein. If so, it may enable coordination of the expression of these operons.

The UAS of the *tyrT* operon harbours at least two binding sites but our data do not exclude a third site, more distant from the transcription initiation site. At least three binding sites are found upstream of the P1 promoter of the *rrnB* operon and three upstream of the *thrU(tufB)* operon. The nucleotide sequences of the three UASs are not identical nor are the sequences of the individual binding sites on each UAS. The affinities for the protein of each site on the UAS of the *thrU(tufB)* operon differ, indicating that the affinity is sequence dependent. Conformational effects, however, may also play a role. All UASs studied here are AT-rich and their DNA helix is bent (Travers, 1984; Drew and Travers, 1984; Gourse *et al.*, 1986). An increase in bending upon protein binding is suggested by DNase I footprinting, showing enhanced cleavage at certain nucleotides within the protected region (Vijgenboom *et al.*, 1989). Conceivably this change in DNA geometry may be, partially or fully, responsible for the lowering of the K_d of the RNA polymerase–DNA complex occurring upon binding of the *trans* activator (Figure 3).

The role of FIS

The identity of the *trans* activating protein has remained obscure for some time. Various lines of evidence favoured the suggestion that EF-Tu is involved: (i) Specific binding to the UAS of the *thrU(tufB)* operon occurs upon incubation with a 95% pure EF-Tu.GDP preparation, isolated by affinity chromatography on GDP–Sepharose. (ii) This binding is inhibited by kirromycin (Vijgenboom *et al.*, 1988). (iii) Experiments in which *tufA* was inactivated by Mu insertion suggested that the expression of *tufB* is dependent on a functional *tuf* gene and thus on EF-Tu, acting *in trans* (Vijgenboom and Bosch, 1987; Vijgenboom, 1989). (iv) *In vitro* synthesis of rRNA was reported to be stimulated by EF-Tu (Travers, 1983), although this could not be confirmed by other investigators. Our present and previous experiments clearly demonstrate, however, that EF-Tu itself does not bind to the DNA, but a single protein that co-purifies with EF-Tu on GDP–Sepharose and that can be separated from EF-Tu.GDP on a Mono Q column.

Evidence for the identity of the separated protein and FIS is circumstantial. The two proteins correspond in size and in DNA binding pattern. Both form the same number of DNA–protein complexes. They also resemble each other in their effect on the DNA conformation and even in function. FIS is a heat-stable protein of 98 amino acids (Johnson *et al.*, 1988; Koch, 1988) ($M_r \sim 12\ 000$) that plays a role in site-specific recombination, mediating the inversion of DNA segments. A family of prokaryotic inversion systems has been described, such as the Gin system of bacteriophage Mu (Kahmann *et al.*, 1985), the Hin system

of *Salmonella typhimurium* (Johnson and Simon, 1985) and the Cin system of bacteriophage P1 (Huber *et al.*, 1985). The inversions are highly stimulated by FIS binding to a *cis*-acting recombinational enhancer sequence. The enhancer contains two specific FIS binding sites separated by a well defined intervening sequence that allows for a conformational change of the enhancer DNA upon its interaction with FIS (Hübner *et al.*, 1989). This change is manifested by DNA bending and is an essential step for recombinational enhancer activity (Hübner *et al.*, 1989). As pointed out above, *trans* activation may be mediated, at least partially, by bending of the UAS DNA helix which seems to be enhanced upon protein binding. The sequences of the protein binding sites on the UASs of the *tyrT*, the *thrU(tufB)* and the *rrnB* operons fit the consensus of the Fis binding sites compiled by comparing recombinational enhancers (Hübner and Arber, 1989). The *in vitro* binding of FIS to the UAS of the *thrU(tufB)* operon and the FIS-dependent *trans* activation of the operon *in vivo* (see below) are in good agreement with the proposed regulatory role of FIS. It remains to be seen whether FIS by itself is sufficient for *trans* activation or that accessory proteins are involved.

FIS-dependent *trans* activation *in vivo*

The *trans* activation mechanism becomes operative under non-steady state conditions, when a rise of the rRNA and tRNA levels is required. This can lead to a burst of promoter activity as is observed with the *thrU(tufB)* promoter when stationary cell cultures begin to grow after transfer to a fresh medium (compare Figure 9). This rapid increase in transcription rate, which is followed by a similarly rapid decline, is clearly dependent on the UAS and FIS. The cellular level of FIS as determined by Thompson *et al.* (1987), is maximal in early log phase when we observe a burst of promoter activity (Figure 9) and drops 70-fold when cells go from exponential to stationary phase. These data indicate that it is the FIS-dependent *trans* activating mechanism that enables the cell to respond effectively and readily to environmental signals.

Dramatic changes in promoter activities have been observed previously by the group of Venetianer (Lukacsovich *et al.*, 1987), when studying the regulation of the P1 and P2 promoters of the *rrnB* operon under various physiological conditions. These authors pointed out that the *rrn* promoters exhibit a hitherto poorly characterized type of regulation that is associated with outgrowth from the stationary phase or metabolic shift-up. They did not offer any indication concerning the mechanism, nor delimited the DNA determinants in detail. Nonetheless, the phenomena they describe for the *rrnB* operon are strikingly similar to those observed here for the *thrU(tufB)* operon, in agreement with a common control mechanism underlying expression of the two operons.

Stable RNA promoters are considered to be very strong promoters. Nonetheless their nucleotide sequences do not optimally meet the –10 and –35 consensus. Promoter up mutations, increasing the promoter strength of the *rrnB* operon approximately one order of magnitude, are possible (Lukacsovich *et al.*, 1989; Gaal *et al.*, 1989). This suggests that the intrinsic strength of stable RNA promoters is maintained at moderate levels in order to enable transcription modulation through *trans* activation.

Regulation of stable RNA synthesis by two counteracting

mechanisms, one operating by activation the other by repression, may be highly advantageous to the cell. Fine tuning of this process under varying environmental conditions may be better realized than by either mechanism alone.

Materials and methods

Strains and plasmids

The *E. coli* strain used for experiments with *galK* plasmids in Figure 9A is AB 2463 (*arg, his, leu, pro, thr, thi, lac, gal, ara, xyl, mnt, strR*; compare Howard-Flanders *et al.*, 1966). The experiments in Figure 9B were performed with MC 1000 [*lacX74, ara D139, (ara, leu) 7697, galU, galK, strA*] and MC 1000-*fis* 767 (*kanA*) (Johnson *et al.*, 1988). LBE 1001 is a wild-type *E. coli* K12 strain. The plasmid pDS10 harbours the *thrU(tufB):galK* operon fusion and has been described by van Delft *et al.* (1987a). The plasmid harbouring the *rrnB* operon were a generous gift of Dr R. Gourse. They have undergone various deletions of the region upstream of the P1 promoter (cf. Gourse *et al.*, 1986). Plasmids harbouring the *tyrT* operon with deletions upstream of the promoter were kindly provided by A. Travers (cf. Lamond and Travers, 1983). They were isolated by CsCl gradient centrifugation.

DNA fragments

UAS fragments were prepared from the corresponding plasmids. UAS fragments of the *thrU(tufB)* operon were obtained by digestion with *Bam*HI and *Clal*, UAS fragments of the *rrnB* operon by digestion with *Eco*RI and *Hind*III and UAS fragments of the *tyrT* operon by digestion with *Eco*RI and *Ava*I. The fragments were isolated by electrophoresis on a 1% agarose gel and end labeled with [³²P]ATP in the presence of T4 polynucleotide kinase. The DNA concentration was determined spectrophotometrically (Maniatis *et al.*, 1982).

Isolation of EF-Tu. GDP

E. coli (strain LBE 1001) cells were grown to mid-log phase, pelleted and resuspended in sonication buffer [25 mM Tris-HCl, pH 8.0, 5 mM Mg(CH₃COO)₂, 175 mM NaCl, 3 mM 2-mercaptoethanol and 50 μM phenylmethylsulfonyl fluoride (PMSF)] at a concentration of 1 g of cells per ml. The suspension was sonicated and the sonicate was centrifuged at 15 000 g for 30 min. The supernatant was dialysed overnight against sonication buffer. The dialysed sample was applied to a 20 ml GDP-Sepharose column and incubated at room temperature for 150 min. The non-bound material was washed successively with 100 ml of sonication buffer and 100 ml of twice concentrated sonication buffer. The bound material was eluted with the same buffer containing 150 μM GDP. The protein was concentrated by ammonium sulphate precipitation at 70% saturation at 0°C, resuspended and dialysed against 50 mM Tris-HCl, pH 8.0, 10 mM Mg(CH₃COO)₂, 10 mM 2-mercaptoethanol, 40 mM ammonium chloride, 100 μM PMSF and 10 μM GDP. The preparation contained >95% EF-Tu.GDP, none of the protein contaminants exceeding 1% of the total protein (as determined by SDS gel electrophoresis).

Separation of EF-Tu.GDP and FIS

The EF-Tu.GDP sample was applied to a FPLC Mono Q column in a buffer containing 50 mM Tris-HCl, pH 7.6, 10 mM MgCl₂, 6 mM 2-mercaptoethanol, 10 μM GDP and 100 μM PMSF. The column was developed with a linear 0–700 mM KCl gradient in the same buffer.

Purified FIS was a generous gift of C. van Zuylen and Professor P. van de Putte.

Protein-DNA binding

Reaction mixtures with a total volume of 20 μl containing 10 mM Tris-HCl, pH 7.8, 100 mM KCl, 5 mM MgCl₂, 1 mM EDTA, 100 μg/ml bovine serum albumin, 0.3 nM labeled DNA fragments were incubated with the protein preparation at 37°C for 10 min. After the incubation 3 μl of 50% glycerol containing 0.25% (w/v) bromophenol blue and 0.25% (w/v) xylene cyanol was added and the samples were loaded on a 5% (w/v) polyacrylamide gel (29:1 acrylamide:bisacrylamide) in 40 mM Tris-acetate, pH 8.0 and 2 mM EDTA. The gels were pre-run for 1 h at 150 V and run at 200 V for 2 h, dried and subjected to autoradiography. The amount of bound DNA was quantified by densitometer tracing of the autoradiogram. Care was taken not to overexpose the film used for the densitometric tracing.

In vitro transcription

EF-Tu.GDP preparation (2 μg) was pre-incubated at 0°C for 30 min in 20 μl 10 mM Tris-HCl, pH 7.8, 100 mM KCl, 5 mM MgCl₂, 1 mM EDTA, 100 μg/ml bovine serum albumin, 100 μM of each ATP, GTP, CTP and

UTP, 5 units RNasin and 0.25 nM supercoiled plasmid DNA. Subsequently RNA polymerase was added and the samples were incubated at 37°C for 15 min. The reaction was stopped by the addition of 50 μl 1 × SSC with 1% SDS and 0.1 μg/ml tRNA. After a phenol/chloroform extraction (1:1 v/v), the RNA was co-precipitated with a DNA probe (extending from position +26 to +109) labeled at the 5' end at position +109. Care was taken to add excess of the probe. The RNA/DNA pellet was dissolved in 5 μl 80% (v/v) formamide with 0.4 M NaCl, 0.04 M PIPES-OH, pH 6.4, and 1 mM EDTA. The RNA/DNA was heat denatured at 80°C for 5 min prior to hybridization for 3 h at 51°C. The sample was treated with 20 units of S1 nuclease at 37°C for 60 min. After precipitation the sample was run on a 7% (w/v) polyacrylamide/8 M urea gel.

Transcriptional activity in vivo

The *E. coli* strains AB 2463, MC 1000 and MC 1000-*Fis* 767 were transformed with a deletion derivative of pDS10. Overnight cultures of the transformant were diluted to an OD₆₀₀ of 0.1 in LB medium (Miller, 1972), supplemented with 0.4% glucose and incubated at 37°C. At times indicated the OD₆₀₀ was measured and samples were withdrawn. Galactokinase activities and plasmid copy numbers were determined according to Adams and Hatfield (1984) with modifications according to van Delft *et al.* (1987b). The activities (pmol phosphogalactose/(fmol plasmid × min)) are expressed as percent of the activities in FIS⁺ UAS⁺ cells at time zero.

Acknowledgements

The plasmids containing the UAS from the *rrnB*, *tyrT* and *thrU(tufB)* and deletion derivatives thereof were generous gifts from Drs R.Gourse, A.Travers and J. van Delft, respectively. The strains MC 1000 and MC 1000-*Fis* 767 from the laboratory of Johnson were kindly provided by Professor P. van de Putte. The valuable help and suggestions from Dr N.Goosen, C.M.van Drunen, C.van Zuylen and H.Verbeek are gratefully acknowledged. The investigation was supported in part by the Commission of the European Communities, Biotechnology Action Programme (BAP), Directorate-General 'Science, Research and Development', Brussels. One of the authors (L.N.) is the recipient of a long-term EMBO fellowship.

References

- Adams, C.W. and Hatfield, G.W. (1984) *J. Biol. Chem.*, **259**, 7399–7403.
- Bauer, B.F., Kas, E.G., Elford, R.M. and Holmes, W.M. (1988) *Gene*, **63**, 123–134.
- Drew, G.R. and Travers, A.A. (1984) *Cell*, **37**, 491–502.
- Duester, G., Elford, R.M. and Holmes, W.M. (1982) *Cell*, **30**, 855–864.
- Gaal, T., Barkei, J., Dickson, R.R., De Boer, H.A., De Haseh, P.L., Alavi, H. and Gourse, R.L. (1989) *J. Bacteriol.*, **171**, 4852–4861.
- Gourse, R.L., de Boer, H.A. and Nomura, M. (1986) *Cell*, **44**, 197–205.
- Haffter, P. and Bickle, T.A. (1987) *J. Mol. Biol.*, **198**, 579–587.
- Howard-Flanders, P., Boyce, R.P. and Therio, L. (1966) *Genetics*, **53**, 1119–1136.
- Huber, H.E., Iida, S., Arber, W. and Bickle, T.A. (1985) *Proc. Natl. Acad. Sci. USA*, **82**, 3766–3780.
- Hübner, P. and Arber, W. (1989) *EMBO J.*, **8**, 577–585.
- Hübner, P., Haffter, P., Iida, S. and Arber, W. (1989) *J. Mol. Biol.*, **205**, 493–500.
- Johnson, R.C. and Simon, M.I. (1985) *Cell*, **41**, 781–791.
- Johnson, R.C., Bruist, M.F. and Simon, M.I. (1986) *Cell*, **46**, 531–539.
- Johnson, R.C., Ball, C.A., Pfeffer, D. and Simon, M.I. (1988) *Proc. Natl. Acad. Sci. USA*, **85**, 3484–3488.
- Kahmann, R., Rudt, F., Koch, C. and Mertens, G. (1985) *Cell*, **41**, 771–780.
- Koch, C. (1988) Ph.D. Thesis, Freie Universität, Berlin.
- Koch, C. and Kahmann, R. (1986) *J. Biol. Chem.*, **261**, 15673–15678.
- Lamond, A.I. (1985) *Trends Biochem. Sci.*, **10**, 271–274.
- Lamond, A.I. and Travers, A.A. (1983) *Nature*, **305**, 248–250.
- Lamond, A.I. and Travers, A.A. (1985) *Cell*, **40**, 319–326.
- Lindahl, L. and Zengel, J.M. (1986) *Annu. Rev. Genet.*, **20**, 297–326.
- Lukacsovich, T., Voros, I. and Venetianer, P. (1987) *J. Bacteriol.*, **169**, 272–277.
- Lukacsovich, T., Gaal, T. and Venetianer, P. (1989) *Gene*, **78**, 189–194.
- Maniatis, T., Fritsch, E.F. and Sambrook, J. (1982) *Molecular Cloning. A Laboratory Manual* Cold Spring Harbor Laboratory Press, Cold Spring Harbor, NY.
- McKenney, K., Shimatake, H., Court, D., Schmeissner, U., Brady, C. and Rosenberg, M. (1981) In Chirikjian, J.G. and Pappas, T.S. (eds), *Gene Amplification and Analysis. Structural Analysis of Nucleic Acids by*

- Enzymatic Methods*. Elsevier/North Holland, Amsterdam, pp. 383–415.
- Miller, J.H. (1972) *Experiments in Molecular Genetics*. Cold Spring Harbor Laboratory Press, Cold Spring Harbor, NY.
- Nomura, M., Gourse, R. and Baughman, G. (1984) *Annu. Rev. Biochem.*, **53**, 75–117.
- Thompson, J.F., Moitoso de Vargas, L., Koch, C., Kahmann, R. and Landy, A. (1987) *Cell*, **50**, 901–908.
- Travers, A.A. (1973) *Nature*, **224**, 15–18.
- Travers, A.A. (1984) *Nucleic Acids Res.*, **6**, 2605–2618.
- van Delft, J.H.M., Marion, B., Schmidt, D.S. and Bosch, L. (1987a) *Nucleic Acids Res.*, **15**, 9515–9530.
- van Delft, J.H.M., Schmidt, D.S. and Bosch, L. (1987b) *J. Mol. Biol.*, **197**, 647–657.
- Vijgenboom, E. (1989) Ph.D. thesis, Leiden University, the Netherlands.
- Vijgenboom, E. and Bosch, L. (1987) *Biochimie*, **69**, 1021–1030.
- Vijgenboom, E., Nilsson, L. and Bosch, L. (1988) *Nucleic Acids Res.*, **16**, 10183–10197.

Received on September 14, 1989; revised on October 27, 1989