

January 2012

QoS ANALYSIS FOR SCHEDULING SCHEMES IN WIRELESS NETWORKS

N. Mahendran

Dept of ECE, M.Kumarasamy College of Engineering, Karur, India, Mahe.sec@gmail.com

Follow this and additional works at: <https://www.interscience.in/ijcns>



Part of the [Computer Engineering Commons](#), and the [Systems and Communications Commons](#)

Recommended Citation

Mahendran, N. (2012) "QoS ANALYSIS FOR SCHEDULING SCHEMES IN WIRELESS NETWORKS," *International Journal of Communication Networks and Security*: Vol. 1 : Iss. 3 , Article 10.

DOI: 10.47893/IJCNS.2012.1035

Available at: <https://www.interscience.in/ijcns/vol1/iss3/10>

This Article is brought to you for free and open access by the Interscience Journals at Interscience Research Network. It has been accepted for inclusion in International Journal of Communication Networks and Security by an authorized editor of Interscience Research Network. For more information, please contact sritampatnaik@gmail.com.

QoS ANALYSIS FOR SCHEDULING SCHEMES IN WIRELESS NETWORKS

N.Mahendran

Dept of ECE, M.Kumarasamy College of Engineering, Karur, India

Email: Mahe.sec@gmail.com

Abstract- In wireless environment, the periodic moments of wireless networks may cause the fluctuation of available bandwidth by varying with time and location. The periodic fluctuation disturbs the resource distribution and Quality of Service (QoS). QoS design is the fundamental functionality of the networking router to enable differentiated delivery and to guarantee the delivery quality for different service traffic classes. By differentiating service classes with appropriate scheduling algorithms, improve the performance of QoS. In this paper, we investigate the compensation issues of fair and priority scheduling algorithms and propose a efficient adaptive bandwidth allocation algorithm for wireless networks, called Adaptive Rotating priority Queue (ARPQ). We evaluate the performance and effectiveness of each scheduling algorithms to meeting the desired QoS requirements.

Index Terms – Wireless, Scheduling algorithms, Quality of Service

1. Introduction

IEEE 802.11 Wireless Local Area Networks (WLANs) have been employed in offices, homes, campuses successfully. Although many wireless networking technologies, such as IEEE 802.16 wireless metropolitan area networks and 3G networks are deployed for wireless internet services. IEEE 802.11 WLANs are good solution for high speed wireless access networks [1]. Since wireless channel capacity is limited, it must be shared among users fairly, and an adequate capacity should be allocated to applications depending on service requirements [2]. The moment of networks causes the bandwidth fluctuation on its wireless link depends on varying time and location. Hence the resources can't be share to all users in the network [3]. The QoS design of networking has been an attractive and significant issue of wireless network. Thus, fairness and quality of service (QoS) are two imperative issues in allocating wireless channels. The best solution for

this problem is scheduling algorithms [2]. The scheduling scheme dynamically changes the weights of various traffic classes to optimize the resource allocation.

In this paper, we discuss about detailed survey of existing scheduling algorithms in wireless networks. The well known scheduling algorithms are Fair Queue (FQ) and Priority Queue (PQ). Most FQ algorithms designed for wireless network to distribute the available resources to all users in the session with fixed weights. As an improvement of static FQ algorithm, some FQ using dynamic weight distribution to provide session requirements [4]. Priority queue ensures that important traffic gets the fastest handling at each point where it is used. It was designed to give strict priority to important traffic. Arriving packets are assigned appropriate priority and classified by a priority-list mechanism. During transmission, Priority queue gives preferential treatment for higher-priority queues over low-priority queues [3]. FQ algorithms, does not consider the capacity variation, it can introduce *static weight-delay* problem. PQ algorithms allocate more resources to higher priority classes; it can introduce the *starvation problem* in wireless network.

In order to overcome the problems of fair and priority queuing, Yaning Wang [4] proposed a new adaptive bandwidth algorithm, called Adaptive Rotating Priority Queuing (ARPQ). Based on the application and traffic classes, ARPQ work as fair and priority queuing. As a priority scheduling, ARPQ classify the packets with different priorities. As a fair scheduling ARPQ provide fairness for lower priority packets. The maximum amount of bandwidth in higher priority queues transferred to lower priority queues.

The remainder of the paper is organized as following: section 2 analyses the existing packet scheduling algorithms, their merits and demerits and newly adopted algorithm adaptive rotating priority queuing also presented. Section 3 makes the detailed comparisons of fair and priority queuing with adaptive rotating priority queue to evaluate their performance in wireless network environment. The section 4

presents simulation comparisons of scheduling algorithms and finally, we conclude and give perspectives of future works.

2. Scheduling Schemes in WLANs

The objective of scheduling schemes is to provide fairness and quality of service among all users in the session, also reduces the packet loss and delay in wireless environment. A lot scheduling schemes are developed in WLANs. The basic schemes are Fair Queuing (FQ) and Priority Queuing (PQ).

2.1 Fair Queuing Schemes in WLANs

The basic FQ scheme refers Weighted Fair Queuing (WFQ). WFQ[3] is a variation of Fair Queue algorithm proposed for reasonable and sufficient QoS mechanism in wireless error free network. The underlying idea of Fair Queue is to serve sessions with some prespecified service shares. WFQ allots a set of weights to each class queue. The weights sets may be the time-sharing mechanism. Such a mechanism prevents the low priority queues from starving. But in wireless network, error free channel is not possible, because error will be introduced during the transmission of packets between base station and mobile nodes.

T.S. Eugene Ng [5] analysis the problem of existing WFQ and introduced new fair queuing algorithm as Idealized Wireless fair queuing (IWFQ), to improve the performance of WFQ with error network. IWFQ have constant bandwidth in base station, to compensate the available bandwidth to all users connected to the base station. For example consider two sessions as X and Y. if the link status is poor while X transmitting, IWFQ stores the lagging size of X. when the session link of X good, IWFQ transmit more packets to this link, to compensate the lagging.

CIF-Q [5] refers Channel condition Independent packet Fair queuing algorithm for systems with location – dependent channel error. In order to find the service lost or gained, we assume each system R , a reference error-free system Rr . The sessions classified as leading and lagging with respect to Rr . If the session is leading, it receives more packets. If the session refers lagging, it receives less number of packets. Working CIF-Q compared the virtual time and real time from reference and real time systems. From the comparison results, scheduler finds the lagged queues and makes compensation to provide fairness.

During the transmission of packets through wireless link, some of the packets are errored. In order to overcome that problem P.Agarwal [6] introduced an algorithm as Server

Based Fairness Approach (SBFA). The basic idea of SBFA is to supplement the bandwidth of session which have received reduced throughput due to poor quality of wireless channel. Scheduler keeps track of the amount of fixed bandwidth in compensation server, At working SBFA, allocate the fixed bandwidth to errored packets from compensation server.

TD-FQ [7] addresses the problem of delays in real time flows with smaller weights. Scheduler is developed based on CIF-Q[], it adds extra mechanism to reduce queuing delays of real-time flows by giving higher priorities. Let flow i is assigned to weight Ri to represent the ideal fraction of bandwidth. The services received by flow I may not match exactly its assigned weights. So we maintain a virtual time V_i to record the services and lagging level lag_i . The normalized service received by flow I is $v_i - lag_i/ri$. Flow I is called leading, if $lag_i > 0$, and called lagging, if $lag_i < 0$, and called satisfied if $lag_i = 0$. Depending on its queue content, a flow is called backlogged if its queue is nonempty, called unbacklogged if its queue is empty, and called active if it is backlogged or unbacklogged but leading. Whenever a flow I transits from unbacklogged to backlogged, its virtual time v_i is set to $max\{v_i, min_{j \in A}\{v_j\}\}$, where A is the set of all active flows.

Y.Wang [8] proposed Muliti Rate Fair Queuing (MR-FQ) for transmitting packets through errored wireless link. Scheduler allows a flow to transmit a different rate according to its channel condition and lagging degree. The idea of MR-FQ is to separate real-time flows from non-real-time flows and compensates real time lagging flows with higher priorities to reduce their delays. It satisfies the delay sensitive property of real-time applications and not starves non-real-time flows. Let the active flow I with the smallest virtual time V_i is selected, if flow I is backlogged, the rate selection scheme is called to compute the best rate R to transmit for flow I , virtual time is updated as:

$$v_i = v_i + \left(\frac{l_p}{w_i} \times \frac{c_1}{r} \right)$$

l_p Refers packet length, the ratio $\frac{c_1}{r}$ reflects the concept of time fairness .

Basically wireless channels are introduce errors, to ensure fairness. Existing fairness algorithms only suitable for single-hop wireless channels. H.L.Chao proposed two protocols for wireless ad-hoc network under channel error to ensure fairness such are TBCP,CSAP[9]. Timestamp-Based Compensation Protpcol works based on start time fair queuing. The scheduler trasmit the packets depends on three parameter.1.number of slots per frame,2.service tag of the

packet and 3.Q-size. Let the three flows are $F1 < 5 \ 3 \ 1 >$, $F2 < 7 \ 6 \ 4 >$ and $F3 < 8 \ 2 >$. Assume each frame contains five slots. Scheduler transmit the packet in the order of $< F11, F31, F12, F21, F22 >$. Credit Based Slot Allocatio Protocol works based on predefined credit values to improve the Quality of service in wireless ad-hoc networks.

The above disscussed Fair Queuing algorithms works based on static weight distribution along with error networks. But none of them consider about fluctuation of the available bandwidth and capacity variations, it will *introduce Static-Weight delay* problem in wireless environment.

2.2 Priority Queuing Schemes in WLANs

The most well-known priority algorithms are classified as Static Priority Queue (SPQ), Probabilistic Priority (PP), Earlier Deadline First (EDF) and Rotating Priority Queue (RPQ). Priority queue differentiating the incoming packets based on source and destination address, packet type, sequence number. At working, higher priority packets are processed earlier than the lower priority packets. SPQ[4] uses static configuration and does not automatically adapt the network resources. For example, consider two queues are $Q1 < A \ B \ C >$ and $Q2 < D \ E \ F >$. Each queue having three packets and corresponding priority assigned to this packets are $Q1 < 3 \ 4 \ 6 >$ and $Q2 < 2 \ 1 \ 5 >$. Scheduler transmit the packets in the order of $Q < C6 \ F5 \ B4 \ A3 \ D2 \ E1 >$, but PQ allocate the more resources to the higher priority packets, it produce *starvation problem* in wireless network.

In 1995, Y.jiang reserched the starvation problem with his colleagues[10], they proposed Probabilistic Priority (PP). PP assign the parameter to each priority queue,by adjusting the parameter, scheduler increase the performance of both higher and lower priority classes. Consider the single server system and I classes of packets. The packets having higher class number treated as lower priority. PP scheduler transmit the packets with lower priority even though a packet with higher priority arrived. Consider each queue assigned a parameter $0 <= P_i <= 1$. The queue i is served with probability P_i , then the next queue $i+1$ served with probability $1-P_i$. this process repeats $i+1$ queue, which has parameter P_{i+1} . The queue weight share with the server denoted as W_i , given by,

$$P_i \prod_{j=1}^{i-1} (1 - P_j)$$

P_i and P_j refers probability of queue I and J in the single server system[10].

The time delay between packet transmossion refers deadline. EDF [4] scheduler process the packets depends on

deadline.the deadline equal to the sum of the packet arrival time. The packets are transmitted by increasing order of deadline. EDF creates overhead in the queues due to precise record of each flow deadline brings large overhead and workload to the queue. The overhead creates more delay in the real-time traffic classes.

In order overcome the problem of overhead packets in the queue, Werge [11] introduced Rotatind Priority Queue (RPQ) algorithm in 1943. RPQ rotate the packet from shorter deadline periodically. Both RPQ and EDF provide fairness to all users.

The existing and above discussed priority queuing algorithms provide only solution for *starvation problem* with different angles, but none of them consider about bandwidth fluctuation and resource distribution, it will create *static weight delay* problem in wireless network.

2.3 Adaptive Rotating Priority Queue Scheme

To overcome the problems of starvation and static weight delay in the existing scduling schemes , a new adaptive rotating bandwidth allocation scheme as Adaptive Rotating priority Queue(ARPQ). Adaptive scheduler provide better Quality of Service, transmission gurantee and delay for higher priority classes by controlling the throughput of lower priority classes, also control the bandwidth fluctuation problem by adaptively changes the distributed resources to the different classes.

2.3.1.ARPQ Rotating Process

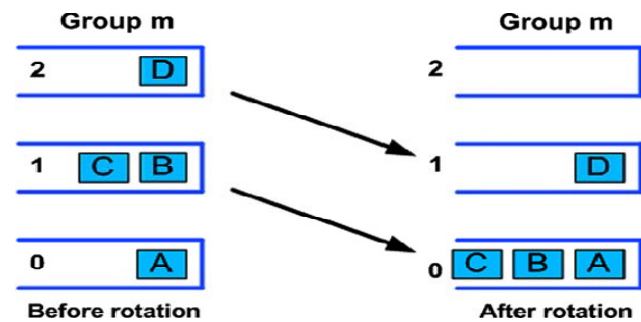

Fig 2.1 ARPQ Rotating Process

ARPQ control the varying capacity and bandwidth fluctuation through rotating scheduler. The scheduler have more number of queue groups with its own priority classes. If packets are entered in to the queue group means, they are stored in to the tail of the corresponding queue group. During the rotating

time, ARPQ shift the packets in higher priority queue groups to lower priority queue groups for every periodic interval of time corresponding to the available bandwidth to control the delay for higher priority classes. From the fig[1], the queue group numbered m has its own rotating time ∂_m . For every ∂_m time packets are transferred from higher class to lower classes. The queuing delay of ARPQ in class m represented as:

$$D_m = T_m + t,$$

Where D_m refers queuing delay of class- m packet, T_m as rotating period and t represents the time that the packet spends in the queue $Q(m, o)$. let R as the waiting time of the first packet rotation and remaining packet rotation waiting time given as W .

$$T_m = (Nm - 1) \cdot W + R \leq NmW$$

The number of queues in the queue group m as Nm . So ARPQ approximately the rotating period of priority class m as

$$\partial_m \leq \frac{D_m}{Nm}$$

From that, we make sure the packets of an unstable priority class will move to queue 0 of its queue group within its delay bound.

2.3.2 Packet Selection Algorithm

At the end of rotating process, packets are queued to the lower priority queues. The packet selection schemes define the order in which the packet are transferred from the stored queues. According to the desired bandwidth for each class, the queue group divide the queue groups in to two types. In first type, the required bandwidth for packet transmission are distributed in to each queue groups. In second type, the limited bandwidth distributed to each queue groups. The existing priority queuing transmit the packet under the type one, if the type one queues are empty, type two queues select the fair queuing policy for packet transmission.

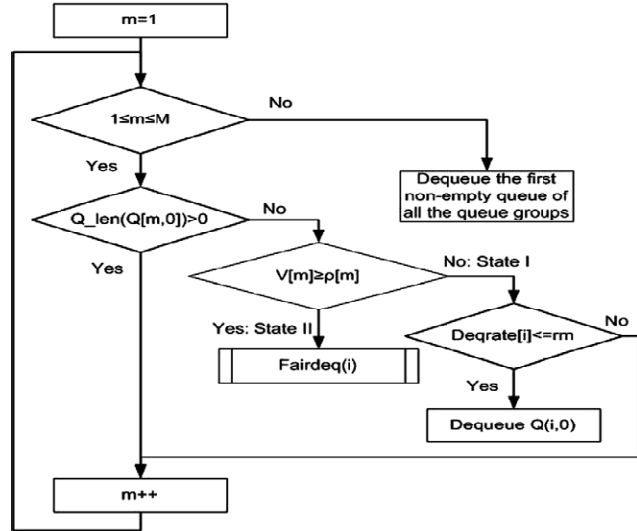

Fig. 2.2 The flowchart of ARPQ packet selecting process

Step 1: Assume that there are M number of classes and queue groups, one class for each queue groups. The scheduler searches the queue groups from 1 to M ($1 \leq m \leq M$) to find the queue group states.

Step 2: If $Q(a,0)$ is empty, the queue moves to next queue group, otherwise the queue group start to check the type, according to the remaining bandwidth of class s , as U_x .

Step 2.1: the U_x higher than the required bandwidth of the class x , G_x , the queue group is in type one, in this type the transmission rate of one class lower than transmission rate of queue group means, the first packet in the queue group will be transmitted, otherwise the queue group moves to the next queue group.

$$r_m = \max \left(U_x - \sum_{x < k < X} \sum_{i \in C_x}^{L[Q(a,0)] > 0} G_i \right)$$

Step 2.2: if U_x lower than the G_x , the queue group x is in type two. In this type, the packet are selected from the queue groups between s and S and transmitted using fair queuing.

3.Simulation and Result Analysis

The Network Simulator (NS) is used to implement the simulation model. The simulation model consists of five source and destination mobile nodes are connected to one core and two edge routers through wireless link. The mobile routers are connects the base station via wireless link with varying bandwidth.

3.1 Result Analysis

In this section, we employ simulation to validate the analysis and to demonstrate the performance of the proposed ARPQ scheme in terms of packet loss and packet delay QoS metric. The analysis done by varying the number of packets size for every particular interval of time.

Fig.3.1, 3.2 shows the Average Delay, Packet loss performance of WFQ in wireless environment. The packet delay performance varying ununiformly (very large packet delay variation) due to fixed weight distribution of resources to all users, causes the static weight delay problem. Fig.3.3,3.4 shows the performance of priority queuing. PQ have lower packet delay and loss compared to WFQ due to differentiation property, but PQ allocate the more resources only to the higher priority classes causes the starvation problem.

To overcome the problems of fair and priority queuing, ARPQ dynamically share the resources between higher and lower priority classes. The dynamic variation reduces the packet delay, loss and provide linear performance as shown in Fig.3.5.

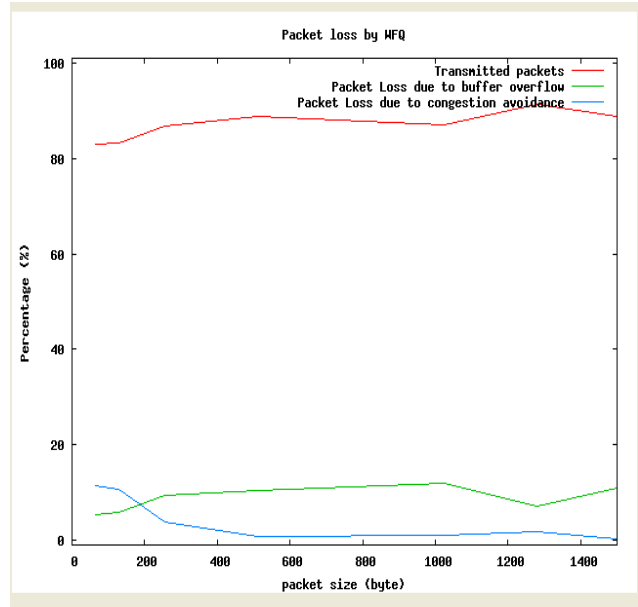

Fig 3.2. WFQ Packet Loss Performance

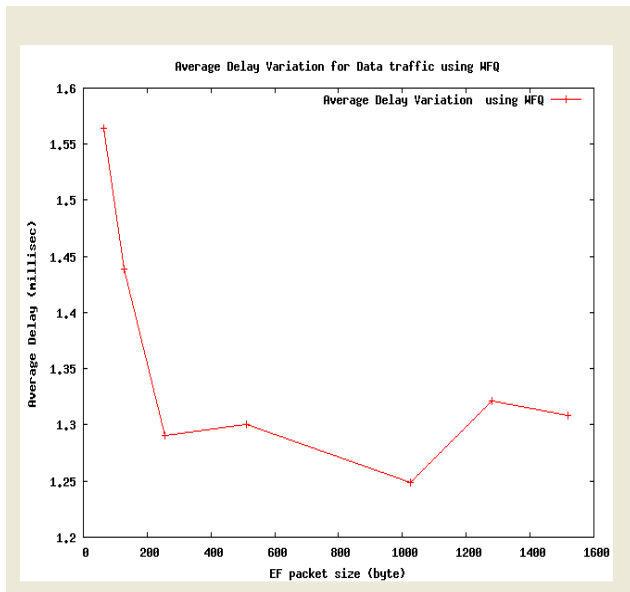

Fig 3.1. WFQ Average Delay Performance

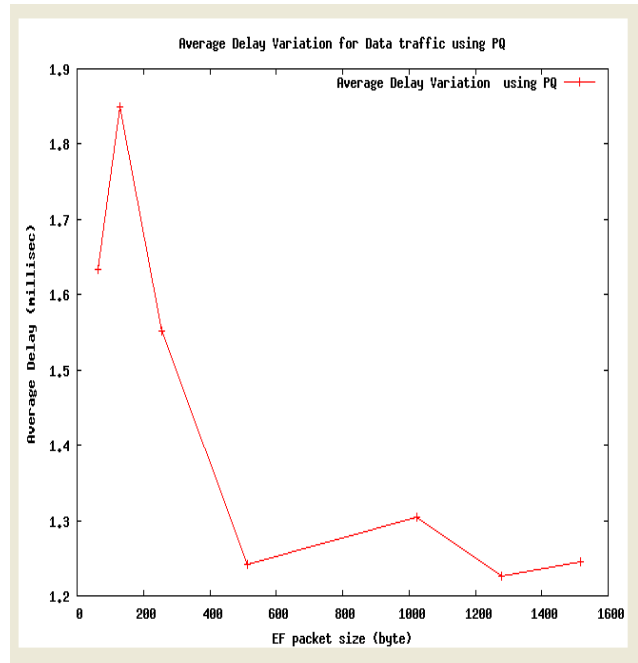

Fig 3.3. WFQ Average Delay Performance

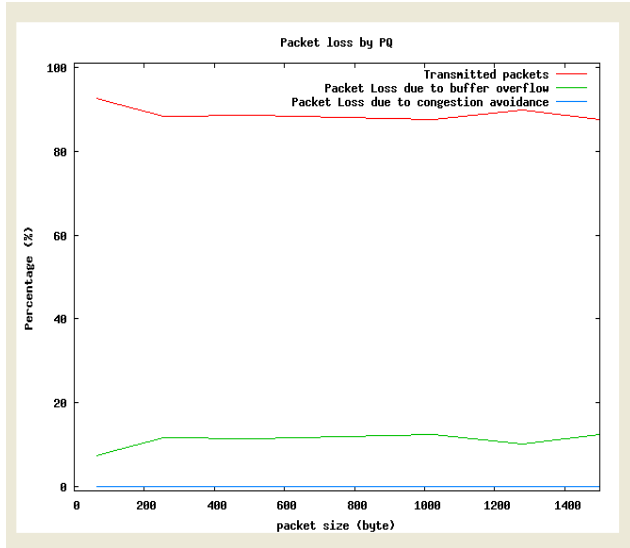

Fig 3.4. PQ Packet Loss Performanc

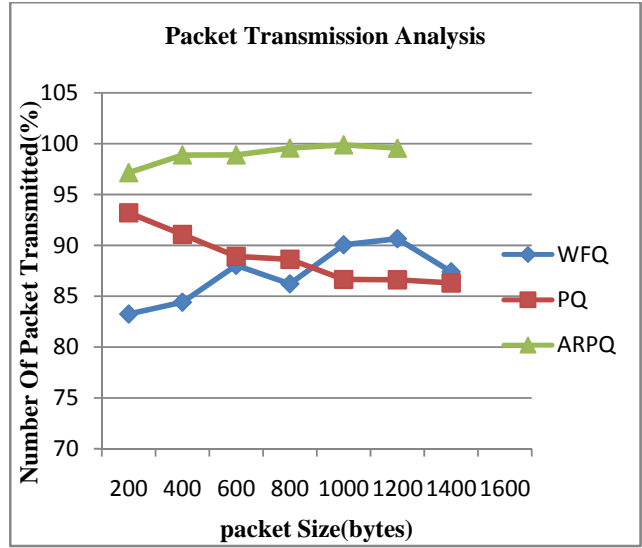

Fig. 3.7

Fig 3.5. ARPQ Average Delay Performance

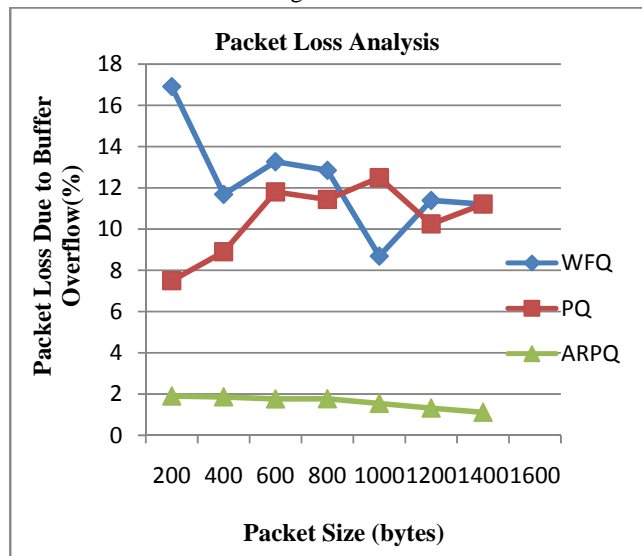
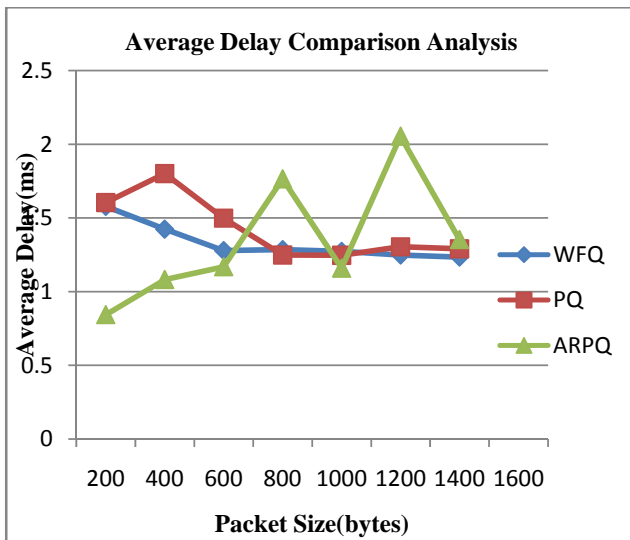

Fig 3.8

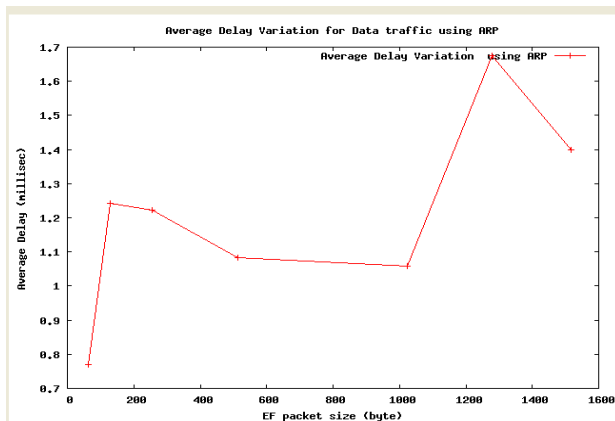

Fig 3.6

Fig.3.6,3.7 and 3.8 shows the comparison analysis average packet delay and packet loss due to buffer overflow,packet transmission analysis for fair, priority and adaptive rotating priority scheduling schemes. ARPQ provide lower average dela, loss and high packet transmission compared to WFQ and PQ schemes. The lower delay and fairness distribution of resources resolve the problems of existing scheduling schemes. Therefore, ARPQ has the best over all performace by combining fairness and priority, also it provides high Quality of Services for all type of classes.

4. Conclusion and Future Work

In this paper, we discuss about detailed survey of existing scheduling schemes and their issues in wireless scenario. The fair queuing works based on pre-assigned weights, priority queuing depends on order of priority classes causes the Quality of Service metrics. The proposed, ARPQ rotates the packets from higher priority classes to lower priority classes periodically for increasing the QoS performance of wireless networks. We also describe the detailed operation of ARPQ and conduct simulations to evaluate the performance.

From the simulation results, we demonstrate that the proposed algorithm satisfies the Quality of Service (QoS) flows and guarantee the delay for higher priority classes and has achieved better overall performance than those of all other existing scheduling schemes. The performance increment of throughput and packet loss is considered for next stage improvements on ARPQ packet scheduling scheme.

References

- [1] Wan-Seon Lim, Young- Joo Suh, Achieving Per-Station Fairness in IEEE 802.11 Wireless LANs, IEEE-2010.
- [2] Eun-Chan Park, Dong-Young Kim, Chong-Ho Choi, Jungmin, Improving Quality of Service and Assuring Fairness in WLAN Access Networks, IEEE Transactions on mobile computing, VOL.6, No.4, APR-2007.
- [3] Mong-Fong Homg, Wei-Tsong Lee, Kuan-Rong Lee, Yau-Hwang Kuo, An adaptive approach to weighted fair queue with QoS enhanced on IP network, in: Proceedings of IEEE Region 10 International Conference on Electrical and Electronic Technology, vol. 1, 19–22 August 2001, pp. 181–186.
- [4] Y. Wang, L. Fan, D. He, R. Tafazolli, ARPQ: A Novel Scheduling Algorithm for NEMO-based Vehicular Networks, submitted to Journal of Selected Areas on Communications, the special issue for Vehicular networks.
- [5] T.S. Eugene Ng, I. Stoica, H. Zhang, Packet fair queuing algorithms for wireless networks with location-dependent errors, in: Proceedings of INFOCOM98, March 1998, pp. 1103–1111.
- [6] P. Ramanathan, P. Agrawal, Adapting packet fair queuing algorithms to wireless networks, in: ACM/IEEE MOBICOM'98, Dallas, TX, pp. 1–9.
- [7] Y. Wang, S.R. Ye, Y.C. Tseng, A fair scheduling algorithm with traffic classification in wireless networks, in: International Symposium on Performance Evaluation of Computer and Telecommunication Systems (SPECTS), 2004, pp. 502–509.
- [8] Y. Wang, Y. Tseng, W. Chen, K. Tsai, MR-FQ: a fair scheduling algorithm for wireless networks with variable transmission rates, ITRE 2005 27–30 (June) (2005) 250–254.
- [9] H.-L. Chao, W. Liao, Fair scheduling with QoS support in wireless ad hoc networks, IEEE Transactions on Wireless Communications 3 (6) (2004).
- [10] Y. Jiang, C.K. Tham, C.C. Ko, Delay analysis of a probabilistic priority discipline, European Transactions on Telecommunications, 2002.
- [11] J. Liebeherr, D.E. Wrege, Priority queue schedulers with approximate sorting in output-buffered switches, IEEE JSAC 17 (6) (1999).