

October 2012

## MAIL SORTER USING LABVIEW

A. NIKHILA

*BMS College of Engineering, Bangalore-19, India, nikhila\_r@yahoo.ie*

NISHA A NAIR

*BMS College of Engineering, Bangalore-19, India, nishanair270290@gmail.com*

KUMUDA S.

*BMS College of Engineering, Bangalore-19, India, kumudaksha2002@gmail.com*

PREETHI K. MANE

*BMS College of Engineering, Bangalore-19, India, preethi\_k\_mane@yahoo.co.in*

Follow this and additional works at: <https://www.interscience.in/ijipvs>



Part of the [Robotics Commons](#), [Signal Processing Commons](#), and the [Systems and Communications Commons](#)

---

### Recommended Citation

NIKHILA, A.; NAIR, NISHA A; S., KUMUDA; and MANE, PREETHI K. (2012) "MAIL SORTER USING LABVIEW," *International Journal of Image Processing and Vision Science*: Vol. 1 : Iss. 2 , Article 10.

DOI: 10.47893/IJIPVS.2012.1022

Available at: <https://www.interscience.in/ijipvs/vol1/iss2/10>

This Article is brought to you for free and open access by the Interscience Journals at Interscience Research Network. It has been accepted for inclusion in International Journal of Image Processing and Vision Science by an authorized editor of Interscience Research Network. For more information, please contact [sritampatnaik@gmail.com](mailto:sritampatnaik@gmail.com).

# MAIL SORTER USING LABVIEW

A. NIKHILA, NISHA A NAIR , KUMUDA S & PREETHI K MANE

BMS College of Engineering, Bangalore-19, India

E-mail : nikhila\_r@yahoo.ie , nishanair270290@gmail.com , kumudaksha2002@gmail.com , preethi\_k\_mane@yahoo.co.in

---

**Abstract** – The Indian postal system is the largest networks in the world. Being the 7<sup>th</sup> largest country in the world, major population of the country is rural based, where the basic amenities of life is a sweet dream. In such a scenario, having an efficient mail delivery system is essential. Hence, to eliminate the drawbacks in other processes, we propose to fully automate the sorting process. Unlike the code generation technique, it neither requires any human intervention to generate a code based on the pin code nor will be a problem in case of absence of the pin code. The principle used for sorting is the Optical Character Recognition using LabVIEW software. Camera, placed over the slide unit captures the image of the address. The pin code or the state (in the absence of the pin code) is selected and compared with a set of trained characters in the data base. On finding a positive match, based on the first two digits of the pin code or the first four letters of the state, the mail is segregated by the LabVIEW program involving OCR technique. The processed data is sent to the real time application by the DAQ card, which activates the actuating arm(servo motor) to allow the letters to move to the respective stack(zone) and thus sorting the mails automatically, reducing the human effort and errors.

**Keywords**-OCR, LabVIEW, DAQ card.

---

## I. INTRODUCTION

Indian post is the most widely distributed postal network in the world. With its service for over 150 years old, it has been the backbone of the nation's communication and has played a crucial role in the country's socio-economic development. It touches the lives of Indian citizens in many ways: delivering mails, accepting deposits under Small Savings Schemes, providing life insurance cover under Postal Life Insurance (PLI) and Rural Postal Life Insurance (RPLI) and providing retail services like bill collection, sale of forms, etc. The sorting has to be done as fast as possible to be received by the recipient on time. This method can include some human errors like misreading the pincodes, misplacing the letters in the wrong stacks, etc. It can also affect the eyes due to constant vigilance on the pincode. To meet the demands, a huge number of people should be employed by the post offices. However, the numbers of people for doing the job are very few. The Indian postal system lacks in the human labour. Hundreds of human beings are required for the task but in reality, only thirty percent of that are available for the job. This increases the labour, fatigue, errors, etc.

In the present day, a lot of techniques are used to sort the mails, other than the conventional manual method. The mails can be sorted using barcode technique, QR code technique and the OCR technique. The most commonly used technique is the barcode generation. Since a barcode is generated from reading the pincode, pincode is the prime necessity in this process. Absence of pincodes makes this process worthless.

QR Code (abbreviated from Quick Response Code) is the trademark for a type of matrix barcode(or two-dimensional code) first designed for the automotive industry. More recently, the system has become popular outside the industry due to its

fast readability and large storage capacity compared to standard UPC barcodes. The code consists of black modules (square dots) arranged in a square pattern on a white background. The information encoded can be made up of four standardized kinds ("modes") of data (numeric, alphanumeric, byte/binary, Kanji), or through supported extensions, virtually any kind of data. This method is not popular as it is as it is worthless in the absence of a pincode.

However, OCR technology has an edge over the above two mentioned processes. This method can sort the mails without a pincode. So this is very advantageous and is gaining momentum.

## II. METHODS OF CHARACTER RECOGNITION

### A. OCR (Optical Character Recognition)

The principle used in our project to read and sort the mails is the optical character recognition. This principle is executed by the LabVIEW software.

Optical character recognition, usually abbreviated to OCR, is the mechanical or electronic conversion of scanned images of handwritten, typewritten or printed text into machine-encoded text. It is widely used as a form of data entry from some sort of original paper data source, whether documents, sales receipts, mail, or any number of printed records. It is crucial to the computerization of printed texts so that they can be electronically searched, stored more compactly, displayed on-line, and used in machine processes such as machine translation, text-to-speech and text mining. OCR is a field of research in pattern recognition, artificial intelligence and computer vision.

OCR systems require calibration to read a specific font; early versions needed to be programmed with images of each character, and

worked on one font at a time. "Intelligent" systems with a high degree of recognition accuracy for most fonts are now common. Some systems are capable of reproducing formatted output that closely approximates the original scanned page including images, columns and other non-textual components.

*B. how does ocr works*

OCR recognizes characters by using two methods - pattern recognition and feature detection [3]

- PATTERN RECOGNITION

In pattern recognition one compares the scanned image with a stored version of various characters. OCR programs to recognize letters written in a number of very common fonts (ones like Times, Helvetica, Courier, and so on) was devised, that meant they could recognize quite a lot of printed text, but there was still no guarantee they could recognize any font that was sent their way. Hence feature detection was developed.[1]

- FEATURE DETECTION



Figure 1: Example of feature detection

The individual component features (angled lines, crossed lines, or whatever) from which the character is made is determined. For example as shown in figure 1 If you see two angled lines that meet in a point at the top, in the center, and there's a horizontal line between them about halfway down, that's a letter A , this rule is applied to recognize most characters by using certain standard features associated with each character to identify them such as in the case of 'A'.

**III. HARDWARE IMPLEMENTATION**

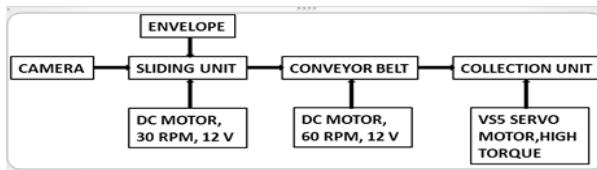

Figure 2: Block diagram of hardware implementation

**SLIDING UNIT:** Comprises of two plates – one movable plate and a fixed plate. After a delay of 5 seconds, movable plate lifts up and the envelope falls onto the conveyor belt. This is run by a 12V DC Motor of 30 rpm. **ENVELOPE:** Inland letters of dimensions 6x4” are designed such that the State name and pincode are written together on the fifth line of the address. It is placed on the movable sliding plate at a predefined position. **CAMERA:** 12 Mega pixel USB camera fixed to the Sliding Structure takes an image of the envelope. **CONVEYOR BELT:** Run by a 12V DC Motor of 60 rpm, through a pulley

system, the belt transports the envelope to the collection unit. By this time the software code would have processed the image and detected the zone it belongs to. **COLLECTION UNIT:** It is operated by a high torque VS5 Servo Motor. Based on the zone detected, it rotates to align the respective box to the conveyor.



Figure 3: The complete hardware structure

**IV. SOFTWARE IMPLEMENTATION**

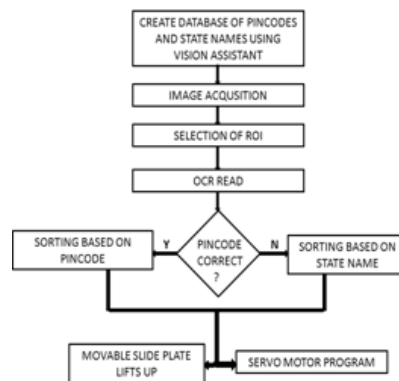

Figure 4: Flowchart depiction of software implementation

The software developed is used to sort mails on a zonal basis – north, south, east and west. A database is created by training scanned and captured letters and alphabets using NI Vision assistant for recognizing state alphabets and pincode numbers by using the method of border recognition of individual character. An image is acquired by using the camera through IMAQDX drivers and creating an OCR session in LabVIEW. A rectangular region of interest (ROI) is selected to feed the state and pincode into the OCR read program [4] [5]. After OCR read if the pincode is correct (encounters consecutive 3 digits) then it extracts the first two digits of the pincode and compares it to the various zones using a case structure. In case the pincode fails then the first four alphabets of the state name is extracted and sorted.

Once the ROI is selected a digital pulse of 12V is used to move the sliding plate by using NI 9178 chassis and NI 9472 DAQ card. After the zone is detected a program is devised on labview to move the servomotor at fixed angles such that it aligns itself with the respective zones on the collection unit. This is achieved by using NI 9178 chassis and NI 9401 which provides PWM signals to move the servomotor.

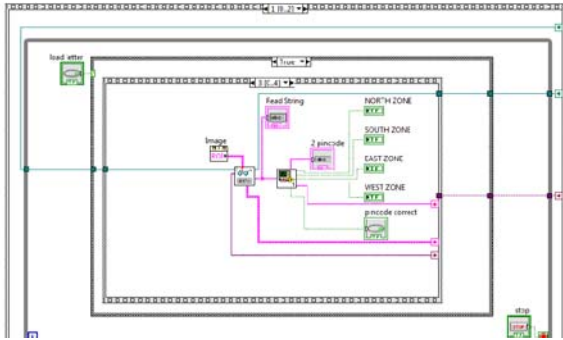

Figure 5: Depicts OCR Read and Zone Sorting

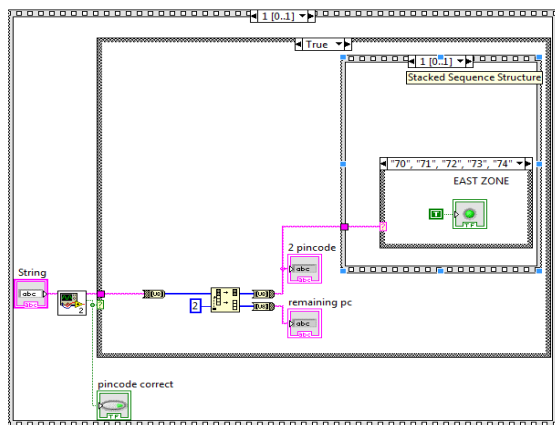

Figure 6: Sorting Into East Zone Based On Pincode Extraction

**V. RESULTS AND ANALYSIS**

After carrying out test runs using the entire setup in its integrated form, the following results were tabulated.

Table 1: Result tabulation

SLIDE ON DURATION		LETTER INPUT ZONE	OCR DISPLAY		DETECTED ZONE	
EXPECTED	OBTAINED		EXPECTED	OBTAINED	EXPECTED	OBTAINED
5	6.37	NORTH	DELHI&110051	DELHI&110051	NORTH	NORTH
5	6.25	EAST	WEST BENGAL&700091	WEST BENGAL&700091	EAST	EAST
5	6.40	SOUTH	KERALA&695009	KERALA&695009	SOUTH	SOUTH
5	6.37	NORTH	JAMMU&KASHMIR &180002	JAMMU&KASHMIR &180002	NORTH	NORTH
5	6.39	WEST	MAHARASHTRA&400051	MAHARASHTRA&400051	WEST	WEST
*5	5.80	SOUTH	KARNATAKA&5600075	KARNATAKA&5600057	SOUTH	NORTH

\*Deviated result

- For all cases the movable plate of the sliding unit moved 45degrees as expected and went up for duration of 2 seconds as expected and prevented damage to the motor.
- Desired result/performance obtained.

**VI. CONCLUSION**

‘Mail Sorter using LABVIEW’ is a step towards technological advancement, it segregates printed letters on zonal division basis by using the highly advanced technology of OCR and software LABVIEW powered by National Instruments. Integration of above software and hardware provides us with the automatic Mail Sorter This method is highly efficient in sorting printed mails... This method facilitates sorting even in the absence of pincode.It is time efficient and can sort mails of any color.

**VII.FUTURE SCOPE**

One can further automate, variable masks by installing and programming variable ROI by scanning. Further sorting can be carried out for local district and main road level by updating and widening the data base... The technique can be extended to read handwritten mails using neural networks and fuzzy logic. The algorithm behind this will identify any type of handwriting. If trained further, fuzzy logic can help identify and read different languages.

**REFERENCE**

- [1]. Hu, M. K., "Visual Pattern Recognition by Moment Invariant", IRE Transaction on Information Theory, vol IT- 8, pp. 179-187, 1962.
- [2]. Naito, T., Tsukada, T., Yamada, K.s Kozuka, K., and Yamamoto, S., "Robust license- plate recognition method for passing vehicles under outside environment", IEEE. Transactions on Vehicular Technology, vol: 49 Issue: 6, pp: 2309-2319, 2000.
- [3]. Cowell, "characters", Proceedings of the IASTED International Conference on COMPUTER GRAPHICS AND IMAGING, Honolulu, Hawaii, USA, pp. 201-206, 2001.
- [4]. Hansen, H., Kristensen, A. W., Kohler, M. P., Mikkelsen, A. W. , Pedersen J. M., and Trangeled, M., "Automatic recognition of license plates", Institute for Electronic System, Aalborg University, May 2002.
- [5]. Hamami, L., and Berkani, D., "Recognition System for Printed Multi-Font and Multi- Size Arabic Characters", The Arabian Journal for Science and Engineering, vol. 27, no. IB, pp. 57-72, 2002.
- [6]. Ni. Com
- [7]. <http://sine.ni.com/nips/cds/view/p/lang/en/nid/207534>
- [8]. <http://sine.ni.com/nips/cds/view/p/lang/en/nid/208822>
- [9]. <http://sine.ni.com/nips/cds/view/p/lang/en/nid/208809>

