

October 2011

Intelligent Control For Locating Fault in Transmission Lines

Abhijit A Dutta

Dept of Electrical Engg, SVSSCER Nagpur, RTM Nagpur University, abhijitak2003@gmail.com

Mrunalini M. Rao

Dept. of Electrical Engineering, SVSSCER Nagpur, RTM Nagpur University, India, mrunalini17.rao@gmail.com

M.M. Rao

Dept of Electrical Engg, SVSSCER Nagpur, RTM Nagpur University, kadu8448@rediffmail.com

Follow this and additional works at: <https://www.interscience.in/ijica>



Part of the [Aerospace Engineering Commons](#), and the [Mechanical Engineering Commons](#)

Recommended Citation

Dutta, Abhijit A; Rao, Mrunalini M.; and Rao, M.M. (2011) "Intelligent Control For Locating Fault in Transmission Lines," *International Journal of Instrumentation Control and Automation*: Vol. 1 : Iss. 3 , Article 5.

DOI: 10.47893/IJICA.2011.1031

Available at: <https://www.interscience.in/ijica/vol1/iss3/5>

This Article is brought to you for free and open access by the Interscience Journals at Interscience Research Network. It has been accepted for inclusion in International Journal of Instrumentation Control and Automation by an authorized editor of Interscience Research Network. For more information, please contact sritampatnaik@gmail.com.

Intelligent Control For Locating Fault in Transmission Lines

Abhijit A Dutta¹, A.N.Kadu² & M.M.Rao³

^{1&3} Dept of Electrical Engg, SVSSCER Nagpur, RTM Nagpur University,
Dept of Electrical Engg, YCCE Nagpur, India.

E-mail: abhijitak2003@gmail.com, mrunalini17.rao@gmail.com, kadu8448@rediffmail.com

Abstract - This paper presents a new approach for locating fault in transmission line using intelligent control relaying. Fault must be detected at its inception by issuing an output signal indicating this condition. Neural network approach for locating fault can be posed as a pattern-recognition to recognize pure sinusoidal signals as indicators of a normal system condition; abrupt changes of amplitude, phase, or the presence of transient components as indicators of fault. This method uses the fundamental frequency components of voltage and current basically current at pre-fault and post fault condition, measured at each phase from any one end of the selected power system. In this approach the data sets were trained using the available data from the system which comprises of different fault types data, and fault inception angles. This approach of locating fault using intelligent control can be used for supporting a new generation of very high speed protective relaying system.

Keywords— *Distance Protection relaying, Power Systems, Artificial Neural Networks, Fault detection using ANN, ANN relay model*

I. INTRODUCTION

Protecting transmission lines is the major part of power system. The probability of fault occurring on a transmission line is quite large as it is exposed to open environmental conditions. So it becomes a prerequisite for fast detection and clearance of faults and henceforth ensuring security and stability of system as a whole. For ensuring stability of power system the detection of fault along with its classification and then detecting the location of fault is the major criterion. Protective relays for transmission lines uses input voltage and current signals to detect the fault and sends a tripping signal to the circuit breaker to disconnect the line. Voltage and current data used for this purpose generally contain the fundamental frequency signal added with harmonics and DC offset [4]. With digital technology being increasingly applied in power substations, distance relays have experienced some improvements; however, the digital relay is usually designed on the basis of fixed relay settings, they are developed and tested offline when a rich input data is available [1]. Also this technique makes the use of digital signal processing methods which takes time [2] (usually one cycle of system frequency) to determine or locate the fault. They are likely to make incorrect decisions if the signals are noisy. The reach accuracy of a distance relay can therefore be affected by the different fault conditions (particularly in the presence of the DC offset in the current waveforms) as well as network configuration changes. It would be desirable to develop a fast accurate

and robust approach that would perform accurately for changing system conditions [6]

The neural network approach to fault detection can be posed as a pattern-recognition problem the ANN is trained to recognize pure sinusoidal signals as indicators of a normal system condition; abrupt changes of amplitude or phase, or the presence of transient components are used as indicators of fault inception [5]. Current or impedance change and voltage signals can be used for fault detection, but current or impedance change signal is in general more sensitive than voltage to fault inception. Amplitude and phase changes are greater for current or impedance signals than for voltage signals; in addition, the dc-offset of fault current is a clear indicator of many fault conditions. This paper demonstrates that the concept of ANN can be used as an alternative computational concept to conventional approach based on a programmed instruction sequence. The capability of the relay based on ANN theory to keep the reach accuracy when subjected to different fault conditions as well as network configuration changes is shown

II. ARTIFICIAL NEURAL NETWORKS

Artificial Neural Networks (ANNs) are inspired by biological nervous systems and they were first introduced as early as 1960, Nowadays, studies of ANNs are growing rapidly for many reasons:

- ANNs work with pattern recognition at large.

- ANNs have a high degree of robustness and ability to learn.
- ANNs are prepared to work with incomplete and unforeseen input data.

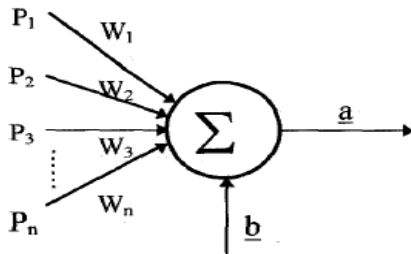

Fig.1- Perceptron representation

Once trained, a network response can be, to a degree, insensitive to minor variations in its input. This ability to see through noise and distortion to the pattern that lies within is vital to pattern recognition. The neuron is the nervous cell and is represented in the ANN universe as a perceptron. Fig. 1 shows a simple model of a neuron characterized by a number of inputs P_1, P_2, \dots, P_N , the weights W_1, W_2, \dots, W_n , the bias adjust b and an output a . The neuron uses the input, as well as the information on its current activation state to determine the output a , given as

$$a = \sum_{k=1}^n W_k P_k + b$$

The neurons are normally connected to each other in a specified fashion to form the ANNs. These arrangements of interconnections could form a network which is composed of a single layer or several layers. As mentioned before, the ANN models must be trained to work properly. The desired response is a special input signal used to train the neuron. A special algorithm adjusts weights so that the output response to the input patterns will be as close as possible to the respective desired response. In other words, the ANNs must have a mechanism for learning. Learning methods for a neural network are Supervised learning (here input and output patterns are provided and a teacher is required to monitor it which can compare the network output and the correct expected output so as to determine the error this is Back propagation Method) next is Unsupervised learning (where the output is not known and the system learns by itself) .

III. BACKPROPAGATION METHOD

The backpropagation algorithm learning of neural network is a closely related approach was proposed by Le Chun (1985). The backpropagation method works very well by adjusting the weights which are connected in successive layers of multi-layer Perceptron.

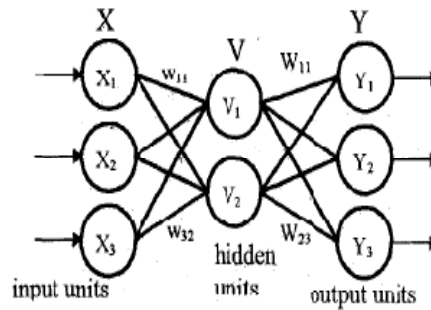

Fig. 2 – Three Layer Artificial Neural Network

The algorithm gives a prescription for changing the weights in any feed-forward network to learn a training set of input output pairs. The use of the bias adjust in the ANNs is optional, but the results may be enhanced by it. A multilayer network with one hidden layer is shown in Fig. 2. The network consists of a set of N input units ($X_i, i = 1, \dots, N$), a set of n output units ($Y_i, i = 1, \dots, n$) and a set of J hidden units ($V_j, j = 1, \dots, J$). Thus, the hidden unit V_j receives a net input and produces the output as

$$V_j = F \left[\sum_{k=1}^N w_{jk} X_k \right] \text{ where } j = 1, \dots, J$$

The final output is then produced as

$$Y_i = F \left[\sum_{m=1}^J W_{im} V_m \right] \text{ where } i = 1, \dots, n$$

The above function $F[.]$ is a non-linear transfer function which can be of various forms. Backpropagation networks often use the logistic sigmoid as the activation transfer function. The logistic sigmoid function maps the neuron input from the interval $(-\infty, +\infty)$ into the interval $(0, +1)$. The logistic sigmoid, shown in the equation below is applied to each element of the proposed ANN.

$$F[.] = \text{logsig}(n, b) = \frac{1}{1 + e^{-(n+b)}}$$

(Where n is the summation of output, bias adjust)

The usual error measure or the cost function for the process is :

$$E[w] = \frac{1}{2} \sum_{i=1}^n [Y_i - Y_i \text{ target}]^2$$

This is clearly a continuous differentiable function of every weight so we can use a gradient decent algorithm to learn appropriate weights. Since the weight error are successfully back propagated from the output layer, this specific training algorithm is known as error back propagation.

IV. FAULT DETECTION AND LOCATING USING ANN

A fault detector must detect the fault inception and to issue an output signal indicating this condition. During normal operating conditions the currents and voltages of the power system are sinusoidal signals. Load variation with time may produce slow amplitude changes in current signals and, in a lesser extent, in voltage signals.

The inception of the fault introduces abrupt changes of amplitude and phase in voltage and current signals. Fault signals can be contaminated with different transient components such as exponentially-decaying dc-offset (mainly in current signals) and high-frequency damped oscillations (mainly in voltage signals), among other components. These changes of amplitude and phase, and the appearance of transient components, can be used to detect the inception of a fault.

The neural network approach to fault detection can be posed as a pattern-recognition problem: the ANN is trained to recognize pure sinusoidal signals as indicators of a normal system condition; abrupt changes of amplitude or phase, or the presence of transient components are used as indicators of fault inception. Current and voltage signals can be used for fault detection, but current signal is in general more sensitive than voltage to fault inception so this signal can be used for locating the fault. Amplitude and phase changes are greater for current signals than for voltage signals: in addition, the dc-offset of fault current is a clear indicator of many fault conditions. Therefore, current signal can be selected as input signal to the fault locator.

After analyzing number of fault states like: fault types, fault location, fault inception angle number of

inputs taken were 20 with two hidden layer(size can be altered) and 1 output for Fault Classifier.

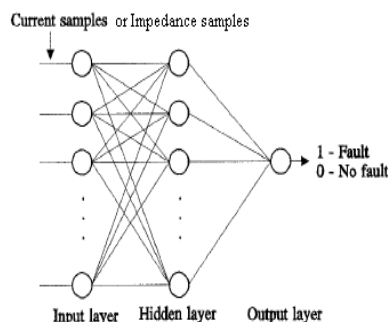

Fig. 3 – ANN- based fault locator structure

The structure of the ANN-based fault locator is depicted in Fig. 3. Input current is low-pass filtered before a set of consecutive samples of current signal form the input to the neural network. Using a 1kHz sampling rate (10 samples per 50 Hz cycle), data windows with different numbers of samples were evaluated. The results are presented for data windows containing 20 samples (20 inputs to the ANN). Only two hidden layers was found to be necessary for this application. The output layer requires only one neuron, with a two-state output.

Simulation can be done using the current waveform (fig 7) or by impedance waveform (fig 8). In this paper we are simulating for single phase to ground fault using the impedance waveform (fig 8). The ANN is trained to recognize impedance (when the operating conditions are normal) signals as indicators of a normal system condition; abrupt changes in amplitude of impedance (at the occurrence of fault) components are used as indicators of fault inception.

V. DISCRIMINATION OF PROTECTION ZONE – ANN SOLUTION

The ANN relay is supposed to identify fault and locate it in the first protection zone of the line (covering 80% of the line length) as shown in Fig. 5. In this way, through three phase voltage and current modulus seen near transformer T1 busbar, the scheme should discriminate between faults lying within 80% of the line length and faults outside that zone, giving 0 and 1 answers respectively for the situations described. For faults located within 80% of the line length, the relay should send a trip signal to the equivalent circuit breaker. The relay will be considered to be secure if it responds only to faults within its zone of protection. It should be mentioned that the input variables have to be normalized in order to reach the ANN input level (+/-). Due to the necessity of different scaling for voltages and

currents, the normalized current must be divided by an additional factor. The half cycle Discrete Fourier Transform (DFT) (shown in block diagram fig 4) is used to filter the input data and extract the modulus of the fundamental components. Concerning the ANN architecture, parameters such as the number of inputs to the network, as well as the number of neurons in the input and hidden layers are decided empirically. This process involved the experimentation of various network configurations. It has been observed that the ANN shown in Fig.3 performed satisfactorily using the backpropagation training algorithm. The digitized three phase voltage and current signals at the busbar A are used to feed the ANN scheme

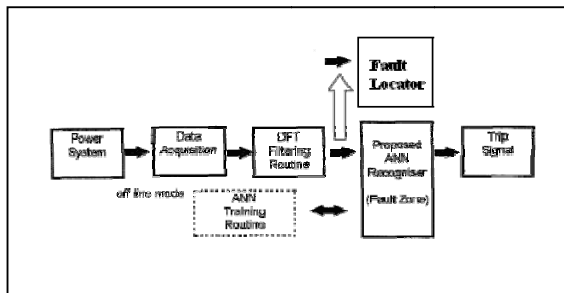

Fig 4: Block Diagram of ANN Distance Relay

VI. ANN BASED RELAY MODEL

The ANN relay in this project is based on a distance relay with two three-phase power sources at both ends. The length of the transmission line (TL) is 100 km. The line model is shown in the fig 5

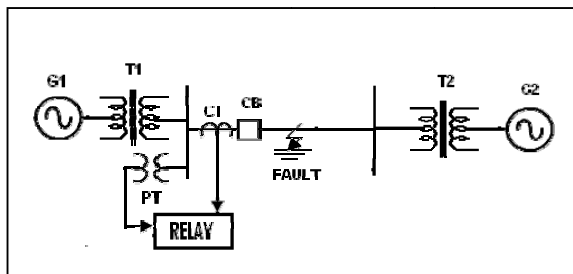

Fig 5: Distance Relay Model

The relay is intended to protect the protection zone along the 100 km line. The ANN relay was trained to see faults from one side (G1) only, i.e. the impedance measured is the one facing the relay. The relay on the other side (G2) can also be used in a similar form.

The distance relay is modeled using PSCAD, to get the data for network training and testing. Looking from the relay A when a fault occurs, the Thevenin impedance will decrease. The magnitude of impedance

varies as the location of the fault changes. Using positive sequence impedance as input neurons. For each fault type and fault inception angle, the location of fault was varied 1,100 fault cases were simulated. Fault patterns is generated using PSCAD (4.2) and the network simulation is done using MATLAB

Some fault types have similar waveform pattern. Given in fig 6. are the waveform patterns for various fault types with constant fault distance. The network input layer requires (input, desired output) pair of input data. The desired output data can be generated by setting a pickup value below which a trip (1) signal is generated.

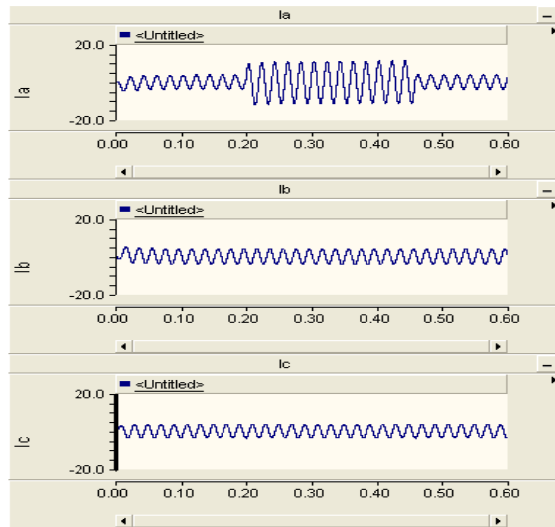

Fig 7: Phase A to ground fault current waveforms

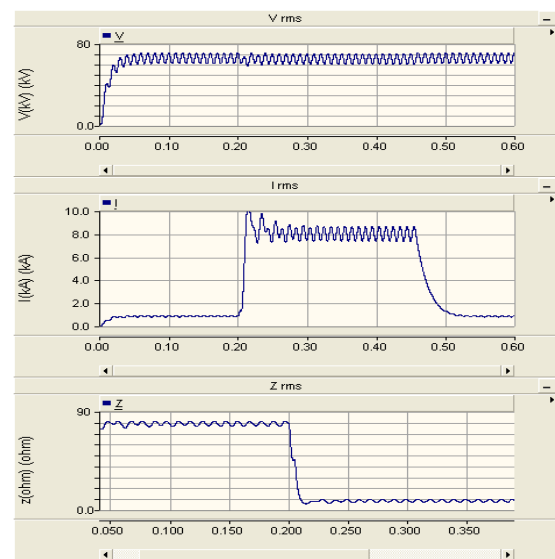

Fig 8: RMS Value of Positive Sequence Current, Voltage, and Impedance

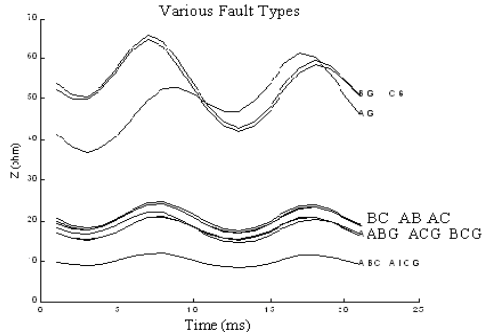

Fig 6: Waveforms of Various Fault Types

After all fault data has been gathered using PSCAD, the input data to the neural network, needed for training, i.e the values of 'Z' are extracted. The output layer has one node with log-sigmoid transfer function. The desired output data set was generated by setting a pickup value below which a trip (1) signal is generated. For all types of fault pattern studied the pick up value for Z was chosen to be 25 Ω. Any impedance below this value would activate the relay. The network is trained which calls ANN functions included in the MATLAB Neural Network toolbox. Before the training is initiated, the training parameters can be changed by changing the learning rate, number of epochs, minimum MSE, momentum change. Once the training is finished, the network then is tested, which simulate the network using data file given in the function parameter and then compare the output with the desired output data to get the performance error.

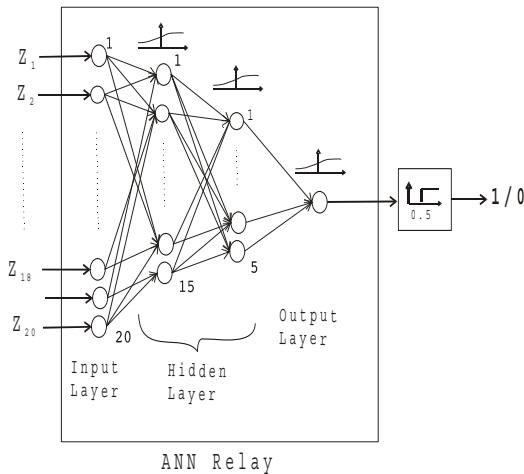

Fig 9: ANN Relay Architecture

The training can be done by arbitrarily choosing network architecture as in fig 9 and then trained it using the proposed learning algorithm. As the size of input and output can be specified, only the size of hidden layer was concerned. The training is started with a big network size and then gradually reduced to smaller size if network testing gave satisfactory result. The location of a fault plays important role in the trip decision when it comes to overreaching issue. When overreaching occurs, the relay ignores it altogether, operates a delayed tripping, or communicates to other relay to trip.

VII SIMULATION RESULTS

The backpropagation algorithm is used for training purpose. The learning process trained a data set of 11,982 values of phase a to ground fault occurring at 30 km from location 'G1' at different fault inception angle. The training shows a minimum error which shows that an ANN relay works very satisfactorily, Simulations were carried for different fault scenarios, the system was modeled in PSCAD and the programmed in M file of MATLAB. From the voltage and current signals we calculated the value of 'Z' which was selected as an input to network and the output node was a threshold value of 'Z' below which the relay was said to trip. The performance of fault classifier and fault locator are shown in the figure 11 and 12. The network architecture was decided empirically which involved the training and testing of both the network. As shown in the performance graph the networks are able to respond to the fault accurately. The fault was identified in a just few ms which shows that the network is able to detect the fault very fast. The performance results are shown in table 2 Also the fault locator testing is done with different fault locations i.e at 10kms, 30kms, 60kms and 90kms. shown in table 3 Performance of the proposed scheme is evaluated for different fault and also for different fault locations. It showed that the relay was able to perform very fast and accurately.

TABLE I
NETWORK TRAINING FOR PHASE A TO GROUND FAULT AT 30KM FROM LOCATION 'G1'

Network size	Fault inception 0.150sec				
	Final MSE	Epoch	Time	Training of 11,982 Data	
				No. of Untrained Data	%
[20 20 1]	0.0015	13	12.7	---	--
[20 15 1]	0.0036	9	9.8	3	0.02
[20 5 1]	0.0033	14	10.4	---	--
[20 20 20 1]	0.0030	10	13.64	---	--
[20 20 15 1]	0.0042	4	9.17	---	--

Network size	Final MSE	Epoch	Time	No. of Untrained Data	%
[20 15 10 1]	0.0040	8	10.4	---	--
Fault inception 0.200sec					
Training of 11,982 Data					
[20 20 1]	0.0035	9	10.6	3	0.02
[20 15 1]	0.0049	6	8.8	---	--
[20 5 1]	0.0043	5	7.7	---	--
[20 20 20 1]	0.0046	10	12.17	---	--
[20 20 15 1]	0.0030	5	9.8	---	--
[20 15 10 1]	0.0023	7	10.2	---	--
Fault inception 0.2 50sec					
Training of 11,982 Data					
[20 20 1]	0.0017	9	10.6	---	--
[20 15 1]	0.0047	10	9.9	3	0.02
[20 5 1]	0.0035	16	10.7	---	--
[20 20 20 1]	0.0040	8	12.2	12	0.1
[20 20 15 1]	0.0019	6	9.9	3	0.02
[20 15 10 1]	0.0037	17	12.2	---	--

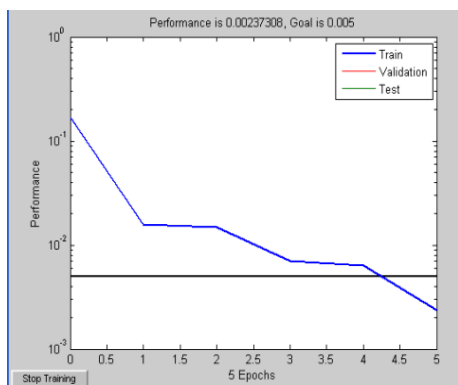

Fig 10 Fault Classifier

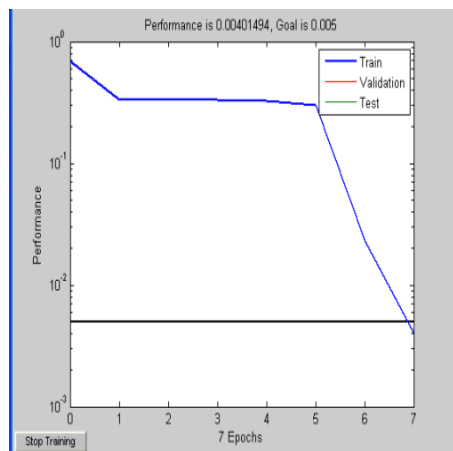

Fig 11 Fault Locator

Table 2 Fault Classifier Results

Fault Types	MSE
LG	0.00237308
LL	0.001272553
LLG	0.0037162
LLL	3.1456e-007
All Faults	0.002203781

Table 3 Locating fault Results

Fault Types Different Locations	MSE
LG	0.00401494
LL	0.00034768
LLG	0.00025947
LLL	9.3914e-006
All Faults	0.001587

VIII. CONCLUSION

ANN relay can provide a fast and precise operation, keeping its reach accuracy when faced with different fault conditions as well as network changes. Also, the use of ANNs has made possible to extend the first zone reach of the relays, enhancing system security. The process involving training and testing of different network configurations can be carried out until satisfactory results are achieved. ANN based relay classifies the fault with input as instantaneous values of voltage and current and locates the fault by taking into consideration instantaneous value of current and fast detection can be achieved. It must however be pointed out that this tool opens a new dimension in relay philosophy, to solve some of the various problems related to the distance protection of transmission lines.

TRANSMISSION LINE PARAMETERS

The line simulation used in this work was a typical 200 kV vertical construction line. The relevant parameters used are:

- (i) Earth resistivity (assumed homogeneous)= 100 Ω.
- (ii) Source X/R ratio = 10
Source sequence impedance ratio $Z_{s0}/Z_{s1}= 1.5$
- (iii) Phase conductor =4x54/7/0.33 s.c.a. with 0.305

bundle spacing earth wire = 54/7/0.33 s.c.a.
(s.c.a.=steel core aluminium)

REFERENCES

- [1] Coury, D.V. & Jorge, D.C. 1998, 'Artificial Neural Network Approach to Distance Protection on Transmission Lines', IEEE Transactions on Power Delivery, vol. 13, no. 1, pp. 102–108.
- [2] T S Sidhu, H Singh, and M S Sachdev, "Design, Implementation and Testing of An Artificial Neural Network Based Fault Direction Discriminator for Protecting Transmission Lines", IEEE Transactions on Power Delivery, Vol 10, no 2, April 1995, pp 647-706
- [3] S.N.Sivanandam, S.Sumathi, S.N.Deepa Introduction to Neural Networks using MATLAB 6.0 TMH
- [4] Coury, D.V. & Jorge, D.C. 1997, 'The Backpropagation Algorithm Applied to Protective Relaying', IEEE International Conference on Neural Networks, vol. 1, pp. 105–110.
- [5] Vazquez, E., Altuve, H.J. & Chacon, O.L. 1996, 'Neural Network Approach to Fault Detection in Electric Power Systems', IEEE International Conference on Neural Networks, vol. 4, pp. 2090–2095.
- [6] Thomas Dalstein, Bernd Kulicke 1995, 'Neural Network Approach to Fault Classification for High Speed Protective Relaying', IEEE Transaction on Power Delivery, Vol. 10, No 2, April 1995, pp 1002- 1011

□□□