

July 2013

ANDROID BASED SECURITY AND REMOTE SURVEILANCE SYSTEM

SENTHIL KUMAR.M

Department of Electrical and Electronics Engineering, G.K.M College of Engineering and Technology, Anna University, Chennai, India, msk_good@rocketmail.com

PADMAVATHY. N

Department of Electrical and Electronics Engineering, G.K.M College of Engineering and Technology, Anna University, Chennai, India, padmavathynau@gmail.com

Follow this and additional works at: <https://www.interscience.in/gret>



Part of the [Aerospace Engineering Commons](#), [Business Commons](#), [Computational Engineering Commons](#), [Electrical and Computer Engineering Commons](#), [Industrial Technology Commons](#), [Mechanical Engineering Commons](#), and the [Physical Sciences and Mathematics Commons](#)

Recommended Citation

KUMAR.M, SENTHIL and N, PADMAVATHY. (2013) "ANDROID BASED SECURITY AND REMOTE SURVEILANCE SYSTEM," *Graduate Research in Engineering and Technology (GRET)*: Vol. 1 : Iss. 1 , Article 17.

DOI: 10.47893/GRET.2013.1016

Available at: <https://www.interscience.in/gret/vol1/iss1/17>

This Article is brought to you for free and open access by the Interscience Journals at Interscience Research Network. It has been accepted for inclusion in Graduate Research in Engineering and Technology (GRET) by an authorized editor of Interscience Research Network. For more information, please contact sritampatnaik@gmail.com.

ANDROID BASED SECURITY AND REMOTE SURVEILLANCE SYSTEM

SENTHIL KUMAR.M¹ & PADMAVATHY.N²

^{1,2}Department of Electrical and Electronics Engineering, G.K.M College of Engineering and Technology, Anna University, Chennai, India

Email:msk_good@rocketmail.com, padmavathynau@gmail.com

Abstract—Mobile phones have been important Electronic devices in our life. Consequently, Home automation and security system becomes one of the prominent futures on mobile devices. In this paper, we have developed the android application that interfaces with the security system using wifi direct technology. The wifi technology is relatively new as compared to other technologies and there is huge potential of its growth and practical application. The android application loaded on mobile devices, can connect with security system and easy to use GUI. The application developed to command lock, unlock or video monitoring of the home. The security system then acts on these command and responds to the user. The CMOS camera and the motion detector are attached with security system for remote surveillance.

Keywords—*android application, wifi, ipcam, motion detector, GUI*

I. INTRODUCTION

Now a day's mobile devices are integrated with our everyday life. The security and remote surveillance system is increasingly prominent feature on the mobile phone. The modern home is integrated with many automation technologies. The user can control door lock, light, air conditioner and other devices using remote control. According to Khan[1], The Access control system used to allow only authorized members while the user away from their house. When the system gets wrong password in three times than it signals to the door alarm. But this technology is very effective when using internet capable mobile devices. Developments in cloud computing and mobile technology allow internet communication in automation and security systems to improve flexible and fast communication, such as Yale's Locks & Hardware new device [2]. This project exploits Near Field Communication through wifi direct. Using X10 technology, the mobile device can control home security system. Priyare and tazil .[3] developed the home automation system through Bluetooth remote control. Sarijari et al. [4] implemented smart home system through zigbee communication. This system relays data and command via SMS message. Noor Azah Samsudin.[5] developed the food ordering system by using the wifi communication to order items with real time feedback. Saliyah Kahar[6] presents comparative study of different wireless technology usage for mobile robot controller such as Bluetooth, WiFi or Wireless LAN and 3G. Saliyah Kahar, Riza Sulaiman .[7] implements the mobile controlled robot, communicates through 3G technology to use advantages of multimedia features and internet speed. The 3G technology offers fast communication than 2G, is used for efficient multimedia data transmission. For long term communication, the 3G communication participate in

important role. The 3G can access high speed data rate at 2mbps. As in [8], applications created include performance-based wireless web, email, as well as video conferencing and multimedia services that blend voice and data streams. This paper discusses the development of security and video surveillance system, which communicates via wifi direct protocol. Android is currently leaded on mobile market share. This proposed system allows user to lock, unlock a door within short range only. The user can also monitor the house. The attached motion detector and CMOS camera is used for remote surveillance. The mobile application requires password to increase the security of the system. The hardware on the door contains the AVR ATmega16 microcontroller to control a linear actuator for locking mechanism and to provide a link between camera and Android mobile. The wifi direct protocol was chosen as communication protocol because it is advanced wifi protocol, operate as adhoc network. The wifi direct protocol has large cover area, compared with Bluetooth. It can be used to communicate up to 200 meters away. The protocol incorporates data encryption for security and interference avoidance.

II. SYSTEM DESIGN

1. Wifi direct on Android mobile devices Wifi direct, is also said as wifi adhoc mode or wifi p2p. Wifi is the short name of wireless federation. It is a WLAN protocol, operates based on the IEEE 802.11 standard. Wifi direct, is a protocol that allows wifi devices to communicate directly without wireless access point with reduced setup. Wifi direct is embedded with software access point that provides a version of wifi Protected Setup with its push button or PIN based setup. When the device enters in the

range of host, it can connect using adhoc protocol and protected Setup style transfer Connection. On comparing with Bluetooth, wifi has

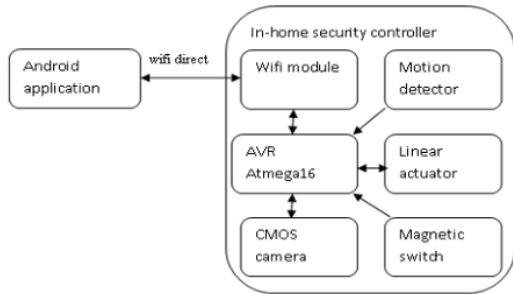

Fig 1 .A diagram of home security and remote surveillance system

high bandwidth, high speed, high coverage area. It is process on 2.4 to 5 GHZ frequency and 600 Mbps bit rate. The wifi direct is used as communication method, because the upcoming Android 4.0 or high versions has already available with embedded wifi direct protocol. To develop wifi direct applications, the API is needed. Android 4.0 SDK or higher versions will provide required libraries for wifi direct application development. 2. In-home security and vigilance controller Fig 1, represents the diagram of a home security system and remote surveillance system using android mobile devices. This system has 3 parts. There are wifi module, Atmega16 controller and CMOS camera. The wifi module makes a link between controller and mobile. The Atmega16 controller with development board acts as a controller. The CMOS camera is a color camera module with digital output, used for video surveillance. Here I2C is chosen as communication method between camera and controller. It uses a CMOS image sensor ov6620 from omnivision. Camera has a digital video port that supplies 8/16 bit wide image data stream continuously. The image can be expressed in different formats, and with different type of channels. The zoom video port format is used in this project which represents 8 bit format as intensity of one pixel. Other 8 bit represents u and v channels, are not used in this project. The PWDN, RST, AGND are connected to ground in the circuit.



Fig 1.B. interface between CMOS camera and Atmega16

The locking mechanism consists of motion detection, linear actuator and magnetic switch. When the electric current is allowed in the actuator circuit then actuator will move linearly. It is used as locker in this project. The motion detection is a human detection

sensor, uses infrared. The magnetic switch makes connection, when the door is locked. It is used as lock identifier sensor. 3. Android SDK and Arduino Firmware android uses a java based language. To develop an android application, a tool named Eclipse is required as well as Android's SDK, which is an add-on for the Eclipse program. To develop wifi direct applications, the Android 4.0 or later version is need.

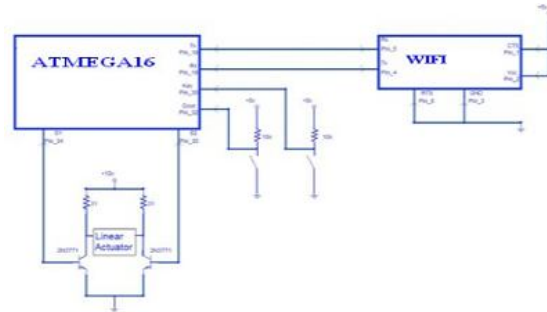

Fig 1 .B. the wiring circuit of in-home security controller

There is three main components are required to develop android application. The first one is java file, which contains the code to implement the desired task. The second one is XML file, which contains the layout for how the application will look to a user, and a resource folder. The resource folder holds all needed images, sounds, graphics files. To implement this project, two programs are developed. The first one is Android application. It is a GUI, creates link with user and mobile. It also creates link with wifi module and communicate commands and video stream via a created link. The second one is high level program for Atmega16 microcontroller. For Arduino firmware, the IDE is provided as the open source by the company [10]. The tool can run on multiple platforms, e.g. windows, Linux and UNIX. This IDE creates a developing environment to develop a microcontroller program. We use embedded C as a high level language to develop this program.

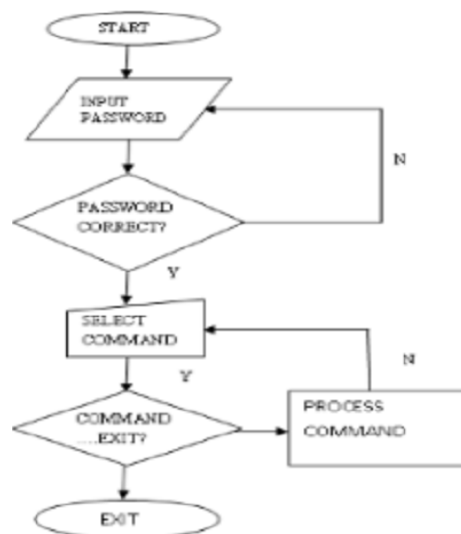

Fig 2. Flow chart of android GUI

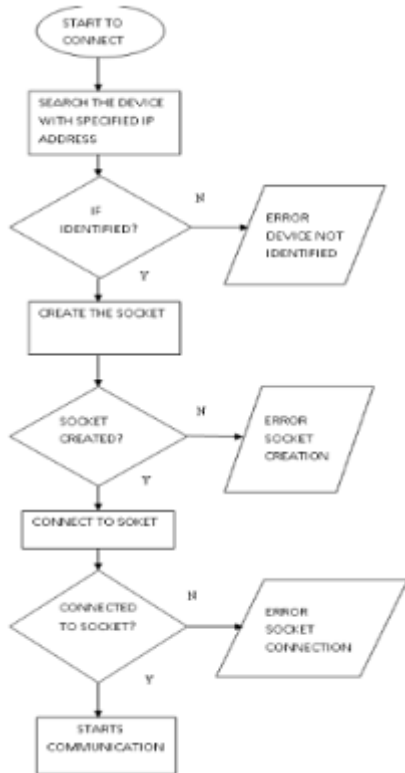

Fig 3 flow chart of socket creation process

The communication link needs more security. The Wifi protocols provide more security for secure connection. An Android application has two methods to create a link. The first one is using IP address of the wifi module directly coded into the app for initial testing. The second one is, it allow users to search for the device, which becomes a final decision. Then user can select the device from a list, for making connection. The basic steps for connecting to wifi module were the same for both versions of the application. Once got ip address of the destination then user can create socket with wifi module. The socket is yet another object in the program, and has to be connected before communications can occur. The input stream reader and output stream writer objects were used to read and write data to the other program.

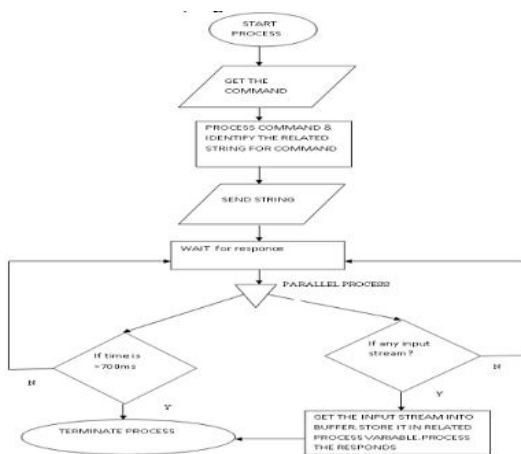

Fig 4 flow chart of command implementation via wifi direct communication process

On comparing with Bluetooth wifi is more secure. The password entry gives more security to the application. Fig 3 shows the flow char to connect wifi to the mobile device. This process consist sequence of three steps. The first one is, the specified device is searched. The second one is socket creation. The third one is socket connection. Fig 4 represents how the communication is implemented. At first the command is got, when the user pressed the command button. Then Android app decides to send appropriate string to the wifi module. The Atmega16 is programmed, how to response to the incoming string. Then it implements the appropriate process then response back to the Android application. To implement this project, the android application and atmega16 program must developed first. The android application needs administrator permission to implement wifi link. The permission is requested in the coding to access the wifi direct protocol. Then we need to create socket between mobile and wifi module, which is attached with atmega16.



Fig 5 shows screenshot of home screen and video display Screen

The Fig 5 shows the finished application which has 3 buttons, first one is lock. It commands to lock the linear actuator. Then the second one is monitor, which displays the remote video stream to the user. The last one is motion, which has a virtual connection. If motion sensor detects any motion hen motion button displays red color line else it will display he green color line in the button. The second image shows the remote video stream. It has a button; labeled back is used to display the home screen.

III. RESULTS

When the project was completed, the mobile device was able o communicate approximately two hundred feet away from he microcontroller through concrete walls. The total time from initiation of a lock/unlock to action was approximately one second. This could be shortened through use of smallerdelays in the program, but delays were left long in this project o ensure that data was sent successfully. The hardware was modified to draw power from a 120V to 12V transformer that was available, so that it could be added to any existing structure. To keep all the

electronics relatively stable, the normal convention of the locking pin in the door was ignored. Instead, the linear actuator was placed in the door jamb, along with the microcontroller and key switch. For demonstration purposes, and to avoid major construction work on the building, a mock door approximately half the size of a standard door was constructed. It consisted of several feet of a false wall, the door jamb, and the door itself. The false wall housed the microcontroller, linear actuator and other necessary circuitry. Since no door this size was available, it had to be constructed. Building both the door and the jamb led to the issue of having them both square, which was a major consideration throughout the construction process.

The frame was made as square as possible, but was not entirely sturdy because it was not part of a larger structure. There was some resistance when the door was opened or closed, but this did not seem to detract from the true purpose of the project. This was thought to be the best solution for demonstration because it was very easy to install and repair the electronics and was portable, so that the project could be demonstrated anywhere with ease. Two major problems arose in the development of this project. The original program prototype for both the mobile device and the microcontroller only communicated a single character to toggle a LED on the microcontroller protoboard.

The mobile device user interface consisted on a single button to transmit the character because the MAC address of the microcontroller was hard coded in. Some problems arose when the second version of the mobile device program was developed. The mobile device was reading and writing to its buffers too quickly and losing data. An addition of a delay to the source code of the application fixed this problem. This problem did not occur in the microcontroller because delays had already been added to that code. Another problem arose in the choice of a suitable resistor value for the transistor array. It had to be a relatively small value, approximately 30 Ω , to supply enough current. While that value was on hand, it would quickly burn up because it drew too much power. This problem was overcome by the use of six 180 Ω resistors that were placed in parallel. IV.

IV. CONCLUSION

The goal of this project was to create a security interface to an Android mobile device. It was also to be a short range system that was simple to use. The range and security aspects were achieved through the use of the onboard wifi direct of the mobile device. Simplicity was a constant factor in design of the user interfaces. The system was able to actuate a pin to lock or unlock a door from a short distance away with the push of a button on the mobile device. It can also display the remote video stream.. Future work would include the design and building of a battery backup system. Improvements to the locking mechanism could also be another aspect for future work. This project could also be expanded to multiple doors and windows. It can be coupled with existing home automation devices to add thoroughness and completeness to the system.

REFERENCES

- [1] Kaur, I., "Microcontroller based home automation system with security," International Journal of Advanced Computer Science and Applications, vol. 1, no. 6, pp. 60-65, 2010.
- [2] Wong, E.M.C., "A phone-based remote controller for home and office automation," IEEE Transactions on Consumer Electronics, vol. 40, issue 1, pp. 28-34, 1994.
- [3] <http://www.engadget.com/2011/09/20/yale-demos-nfc-enabled-residential-locks-germaphobes-rejoice-v/>
- [4] http://www.sears.com/shc/s/p_10153_12605_00903043000P?blockNo=5&blockType=G5&prdNo=5&i_cnr=1323064631801
- [5] Das, S.R., et al., "Home automation and security for mobile devices," IEEE PERCOM Workshops, pp. 141-146, 2011.
- [6] Sarijari, M.A.B., Rashid, R.A., Rahim, M.R.A., Mahalin, N.H., "Wireless Home Security and Automation System Utilizing ZigBee based Multi-hop Communication," National Conference on Telecommunication Technologies, pp. 242-245, 2008.
- [7] Saliyah Kahar, Riza Sulaiman, Anton Satria Prabuwno, Mohd Fahmi. "Data Transferring Technique for Mobile Robot Controller via Mobile Technology" in Pattern Analysis and Intelligent Robotics, International conference. pp 103-108, 28-29 June 2011
- [8] Xichun Li, Abudulla Gani, Rosli Salleh, Omar Zakaria. "The Future of Mobile Wireless Communication Networks". In communication software and networks, 2009 International Conference, pp 554-55, 27-28 Feb. 2009.

