

October 2012

NOVEL DIGITAL LOCK SYSTEM

N. BHUVANESH

Electrical and electronics department, Easwari Engineering College Bharathi Salai, Ramapuram, Chennai – 600 089., bhuvi289@gmail.com

M. GAUTHAMAN

Electrical and electronics department, Easwari Engineering College Bharathi Salai, Ramapuram, Chennai – 600 089., ganekum@gmail.com

Follow this and additional works at: <https://www.interscience.in/ijess>



Part of the [Electrical and Electronics Commons](#)

Recommended Citation

BHUVANESH, N. and GAUTHAMAN, M. (2012) "NOVEL DIGITAL LOCK SYSTEM," *International Journal of Electronics Signals and Systems*: Vol. 2 : Iss. 2 , Article 7.

DOI: 10.47893/IJESS.2012.1091

Available at: <https://www.interscience.in/ijess/vol2/iss2/7>

This Article is brought to you for free and open access by the Interscience Journals at Interscience Research Network. It has been accepted for inclusion in International Journal of Electronics Signals and Systems by an authorized editor of Interscience Research Network. For more information, please contact sritampatnaik@gmail.com.

NOVEL DIGITAL LOCK SYSTEM

¹ N.BHUVANESH & ²M.GAUTHAMAN

^{1&2}Electrical and electronics department, Easwari Engineering College
 Bharathi Salai, Ramapuram, Chennai – 600 089.
 E-mail: bhuvi289@gmail.com, ganekum@gmail.com

Abstract— In this paper we have proposed a new digital lock model which is primarily designed for low cost intermediate security purpose. Even though there are digital locks available this one is designed keeping the common man in mind. It will be the first digital locking system that would be available at a price less than 700 rupees. The recent increase in burglary levels proves the fact that the lever locking system is no more reliable and effective, but on the other hand the present digital locks are around 3000 rupees making it over priced. So this clearly shows the need for an intermediate effective digital locking system. Our novel digital locking system is aimed exactly to solve the above stated problem. Our model is an outcome of embedded system and can works using an 8051 microcontroller interfaced with a 16*2 lcd to perform logical operations. The input is given by the user using 3*3 matrixes key padded system. The locking system consist of a power lock which is widely used in automobiles, it primarily consist of an dc motor which on rotating moves the lever back and forth depending on the direction of rotation. The interrupt pins are used to clear the buzzer which is connected to port 3 pins which thereby notifies the user immediately in case of theft or burglary.

Keywords— key pad, interrupts, power lock, ports, lcd

I. INTRODUCTION

We all rely on basic locks for our day to day security, though it is economical it is very much prone to duplications and they can also be quite easily broken without much indications after its done. On the other hand digital locks are available but are meant for specialized and classified applications like in military, bank lockers and also for surveillance in bungalows etc making them quite expensive for moderate purposes. This makes the user to settle either for a costly digital lock or to a much cheaper lever locks, due to which few important area's are easily accessed leading to missing records, files, jewellery and other important articles. Even the locks used in our home's are vulnerable which when damaged does not alert. These kinds of incidents occur very commonly around us and still continue to happen at an increasing scale. One of the main reason for these types of problems is lack of proper security system in these places. When we use normal lever locks there is no indication or alert once the lock is broke which leads to a delayed notification of the break-in. Microprocessors and controllers are quite commonly used for several applications nowadays. Microcontrollers are capable of carrying out many logical operations with great accuracy, this is the reason why many of embedded system based security devices are being used in several places. So why not implement the same in a smaller scale? The 3*3 key padded lcd code lock model is just meant for the same "intermediate security purpose". As in any embedded system based model it also relies on both hardware and software for its effective functioning. For the output display we use 16*2 lcd segmented display. The whole system is governed by the software which is designed by the

developer with the basic code along with user specified attributes.

II. LOGICAL AND CONTROL UNIT

The control unit for any dsp is the microcontroller/microprocessor section. In our model we use a controller and not a processor, the main reason is that our operations are only meant for a specific purpose whereas processors are used to carry out more general operations specializing in multi tasking. Processors also depend on externally connected memory chips which are totally not needed for this set up. So keeping the above factors in mind we have settled for the 8051 microcontroller. The 8051 µc pin detail is shown in fig 1. The port p2 is used to connect the 16*2 lcd display. The lcd being a processor of its own kind is used to receive information from the 8051 µc and to display the needed contents to the user. The keypad is formed as shown in fig 3, port0 is used to connect the key pads, we have taken a 3*3 keypad but more switches can be accommodated and made to form a even more complex keypad depending on the user specifications. The function of each switch in the keypad is specified by the program.

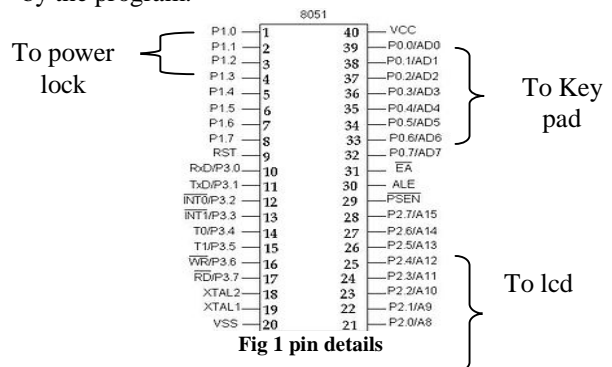

Fig 1 pin details

The program coding is very simple, the password is pre defined by the user so every time the switch in the keypad is pressed the program coding is developed in such a manner that it jumps from one loop to another checking if we are pressing the keys in the correct manner matching to the password. If it does not match even for a single switch then the control of the program is jumped to the error sub-function, if this happens the lcd displays “wrong password” and the lock is undisturbed [6]. On the contrary if the switch is pressed according to the predefined password, then the program moves from one loop to the other checking for our every press. Finally if our pattern matches with the existing one then the lcd displays “open” and the shaft connected through the driver circuit moves outwards unlocking the door or shelf. The block diagram depicts on how the program works so that you can understand the process much better. The coding has also been written for the system and will be showed.

(Let’s assume that the correct pattern is 1 3 2 5)

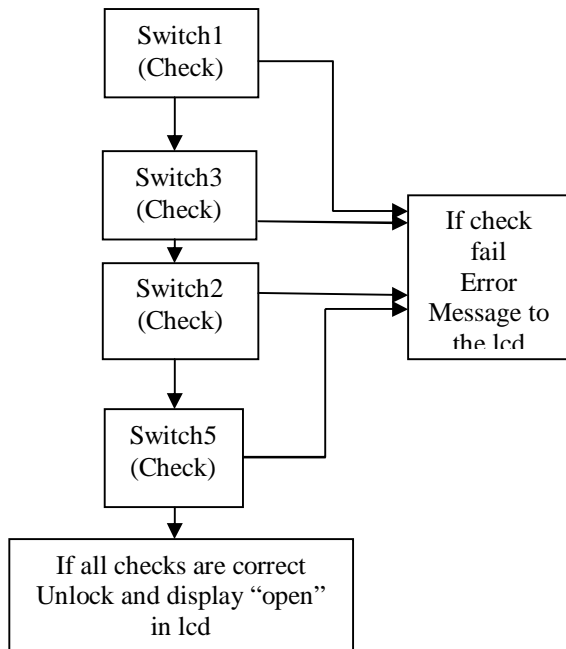

Fig2 Algorithm Explanation

III. PERIPHERAL DETAILS AND MECHANISM

The connections to the power lock circuit cannot be given directly as it might affect the controller. So we use a L293d driver circuit to connect the power lock with the controller safely. As mentioned earlier the power lock system is driven separately. The driver circuit is only to amplify the input from the controller and to prevent the controller from damage. The lcd other than its data pins has read-write, rs and enable pins.

The lcd data sheet is studied and the data and command mode information’s are given through port 0 when required as per the data sheet procedure. A buzzer is connected to port p3 which is triggered when interrupt pins int0 or int1 is modified. The key pads are interconnected as shown in the fig2, initially all the pins in the p0 port are made high and then pin p0.0 alone is made low. If we press any of these switches sw1,sw2 or sw3 it turns its corresponding pins p0.3,p0.4 or p0.5 respectively low. The pins are made high and low using the software and the switches are checked using the jnb and jnb commands. . Similarly for the second column i.e. for switches Sw4, sw5 and sw6 p0.0 is set to 1 and p0.1 is cleared to 0 and in the same process the switches are checked if they are pressed. The same procedure is repeated for the next column too. If more switches are to be placed they are also placed in the same manner Note that the pull-up resistor is absent on Port 0 except when functioning as the external address/data bus. When a 0 is written to a bit in port 0, the pin is pulled low. But when a 1 is written to it, it is in high impedance disconnected state. So when using port 0 for output, an external pull-up resistor is needed, depending on the characteristics of the device driven by the port pin on the input Port 0. The L293D is designed to provide bidirectional drive currents of up to 600-mA at voltages from 4.5 V to 36 V. The device is designed to drive inductive loads such as relays, solenoids, dc and bipolar stepping motors, as well as other high-current High-Voltage loads in

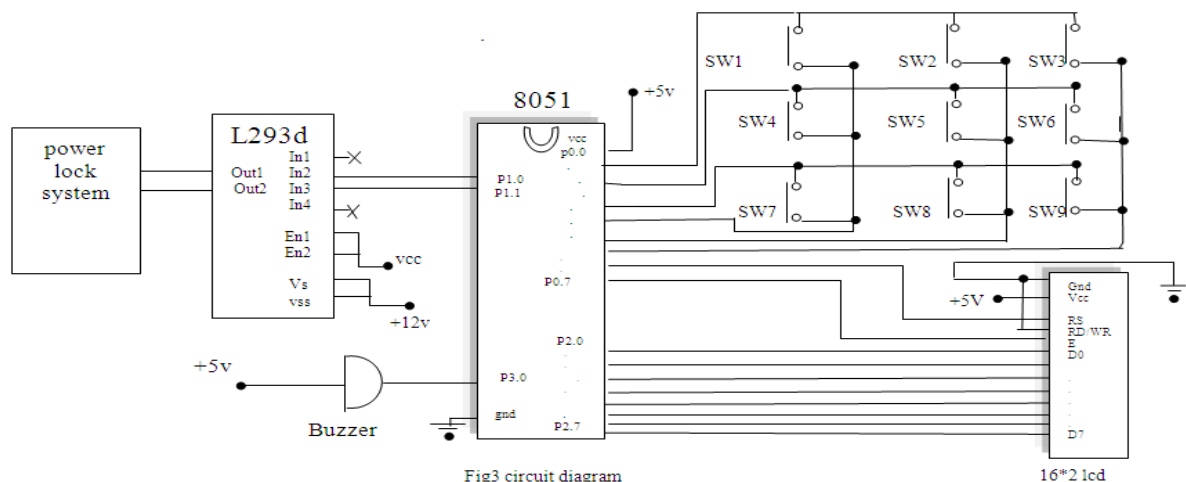

Fig3 circuit diagram

positive-supply applications. The two output pins are connected to the power lock circuit which works on a motor which is present inside the power lock. The small electric motor inside the lock is used to move the plunger arm forward and backward by just changing the polarity of the dc source given to it [1].

The power lock arrangement is widely used in automobile locking systems and is available in kits. In this mechanism it is to be noted that the driver circuit is connected to a switch which activates/locks the power lock when given a high signal and deactivates/ unlocks when again given a high pulse this is achieved by just reversing the polarity of the lock system [2]. It is given supply only for a instance of time and it remains in that position even after the supply is removed.

IV. INTERRUPT MECHANISM

The interrupt mechanism is through which we are alerted in case of any theft or burglary. The interrupt mechanism is carried out in two different processes:

A. INTERRUPT SENSING

The power lock is placed behind the lcd display, and the connections to the lcd are given to the microcontroller which will be placed in the inside this is to guard the controller from attacks, as any damage to it will lead to total failure. The interrupt pin wires are taken and given to the supply through a resistor and it is grounded directly, the connection from the interrupt pin to the ground is given by taking the wire through the power lock system and then to the ground this is because if there happens any damage to the lock it must first rupture these wires surrounding it, this sends signal to the interrupts int0 or int1, once the wire connecting the ground is disconnected then it is set to 1 as the other possible connection is only to the supply through the resistor. This initiates the interrupt process as the interrupt pin is modified from a 0 to 1. The interrupt sub function is called automatically by the controller and the control of the program now jumps to the address 0003 or 0013. The function given in this address is nothing but interrupt handling. In this way the interrupt is sensed. The supply to the lcd and the microcontroller is given through batteries so this prevents the controller to stop due to power cut or other such events. The program flow is always sequential, it will be altered only by those instructions which expressly cause program flow to deviate in some way. Interrupts give us a mechanism to put on hold the normal program flow, execute a subroutine, and then resume normal program flow on the occurrence of the return on interrupt instruction as if we had never left it. This subroutine, called an interrupt handler, is only executed when a certain event occurs. The event may be one of the timers overflowing, receiving a character via the serial port, transmitting a character via the serial port, or one of two external events. The

interrupt is sensed even if the switches are wrongly pressed for more than 6 times, this will be monitored by the program.

B. INTERRUPT HANDLING

The 8051 may be configured so that when any of these events occur the main program is temporarily suspended due to some function related to the event that occurred. Once ended and control passed to a special section of code which presumably complete the execution, control would be returned to the original program. The main program never even knows it was interrupted. Once the interrupts send the signal to the microcontroller then it clears the pin p3.0 starting the buzzer circuit. The buzzer used here is simple 5v buzzer but higher rated buzzer can be placed. The ability to interrupt normal program execution when certain events occur makes it much easier and much more efficient to handle certain conditions. If it were not for interrupts we would have to manually check in our main program whether the timers had over flown, whether we had received another character via the serial port, or if some external event had occurred. Besides making the main program ugly and hard to read, such a situation would make our program inefficient since we would be burning precious instruction cycles checking for events that usually don't happen. So this is how it alerts the security personal's in any event of theft [4]. The buzzer can be made active even using reed switch but it is not reliable for long term application so we have settled for this type of operation using interrupts. The information to the interrupt pins is given by the program when the port2 pins are altered.

V. DISCUSSION

The digital lock system can be modified in many other forms depending on the user needs. For example gsm and ma techniques can be used to send information to the user's cell phone whenever the code is verified or during theft. It can also be used to send information to security panels through wireless data transmission. These would however add to the cost of the initial set-up so implementation of these ideas depends on the level of security needed.

The system is very affordable as mentioned before which can very much influence its market interests. It has got a great chance of even replacing the existing lever lock system in future if it is properly applied. We've tabulated the cost of various components used.

TABLE I
COST ANALYSIS

COMPONENT	COST(RS)
Microcontroller	100
Key pad(9 switches)	20

16*2lcd	150
Driver circuit(1293d)	50
Power locks	200
Buzzer	12
Package cover	50
shafts	50
Total	632

VI. CONCLUSION

On analysing it is quite evident that the digital lcd code lock model can be used in places where intermediate security is needed. It can be turned on when required alone, making it efficient. The system is also flexible to changes as the program can be modified as per the user specifications and the keypad assembly can also be extended if needed. The other main advantage is reliability as we use highly reliable microcontrollers. The most striking aspect is that the system is very cheap unlike other digital security systems, it only costs around 450-650rs including the power lock circuit which makes it affordable.

ACKNOWLEDGMENT

Through this acknowledgment, we express our sincere gratitude to all the staff members of EPR labs, Kodambakam who have supported and have helped us with this paper. Firstly we extend our thanks to Mr. Santhosh Kumar of EPR Labs for supporting us and influencing our work very much. Finally, we express our thanks to professor Mrs. Neena Ramesh and Mr. Zhakeer Hussain of Easwari Engineering College who guided us and gave us valuable suggestions regarding the pa

REFERNCES

- [1] www.miata.net, Power lock details
- [2] www.tsubakimoto.com, Power lock details
- [3] www.engineersgarage.com, Microcontroller
- [4] Information
- [5] www.en.wikipedia.org/wiki/Interrupt, Interrupt mechanism
- [6] www.edaboard.com, pull up resistor information
- [7] www.eprlabs.com, platform for embedded design
- [8] Nagoor Kani, microprocessors and microcontrollers, RBA publications.

