

January 2013

DESIGN AND IMPLEMENTATION OF SMART SENSING PLATFORM FOR ROVER-BACK CANSAT USING CORTEX-M3

E. PADMAVATHI

ECE Department ASCET, India., padma.n2087@gmail.com

Follow this and additional works at: <https://www.interscience.in/ijess>



Part of the [Electrical and Electronics Commons](#)

Recommended Citation

PADMAVATHI, E. (2013) "DESIGN AND IMPLEMENTATION OF SMART SENSING PLATFORM FOR ROVER-BACK CANSAT USING CORTEX-M3," *International Journal of Electronics Signals and Systems*: Vol. 2 : Iss. 3 , Article 2.

DOI: 10.47893/IJESS.2013.1094

Available at: <https://www.interscience.in/ijess/vol2/iss3/2>

This Article is brought to you for free and open access by the Interscience Journals at Interscience Research Network. It has been accepted for inclusion in International Journal of Electronics Signals and Systems by an authorized editor of Interscience Research Network. For more information, please contact sritampatnaik@gmail.com.

DESIGN AND IMPLEMENTATION OF SMART SENSING PLATFORM FOR ROVER-BACK CANSAT USING CORTEX-M3

¹E. PADMAVATHI & ²E. PRABHAVATHI

^{1&2}ECE Department ASCET, India.

¹Email:Padma.n2087@gmail.com

Abstract - In this study, a CanSat with capability of returning back to target is designed and implemented. The CanSat is controlled by a state-of-the-art MBED 32-bit microcontroller. A Zigbee Based Smart Sensing Platform for Monitoring Environmental Parameters has been designed and developed. The smart weather station consists cortex-M3 based measuring units which collect the value of the temperature, relative humidity, pressure and sunlight. These units send their data wireless to a central station, which collects the data, stores and displays them into a database. The facility of adding a few more sensors and a few more stations has been provided. The main components are the pressure, ultrasonic, gps sensors and the 2.4 GHZ transmitter. The mission is planned for two stages which are flight back to the target by a paraglider and roving on the ground on wheels. The process will be monitored on the ground station via the GoogleEarth software. The electronics&hardware design and the control algorithm is discussed in depth in this paper.

Keywords: *Sub-Orbital Flight, CubeSat, Navigation, Zigbee, Smart Sensing, Environmental monitoring.*

I. INTRODUCTION

CANSAT's have gained wide popularity in Aerospace Education [1,2]. Due to their low-cost. Human beings are meteor-sensitive. We feel good, when the sun shines and get melancholic if the sky is grey. The emotion is connected to weather conditions, experiences memories and is one of the most discussed aspects of our live. The Greeks were the first meteorologists (7th century B.C.). Thales of Miletus associated weather with movement of the stars and planets [1]. Since then humans always tried to forecast the weather, to plan sowing and harvesting of plants, to decide how to dress and to plan their outdoor activities.

In the past these forecasts were made by high educated man with a big knowledge and experience later instruments were designed to measure the actual situation, beginning with the first thermometer invented by Galileo in 1593[1].

Since the 1940's forecasts for the weather are computer calculated models, using the previous data of weather stations on the ground collected manually by persons operating this stations, satellite pictures and offshore data collected by measurement buoy. The weather observing is getting more and more automatic, because the manual collection data are not continuously and the variation caused by wrong reading can change the whole forecast in addition the use of a wireless stand alone station can reduce the cost of maintaining the weather station, reduce the risk of losing data and can be placed at critical locations, without endanger an observer. this research motivates to develop a weather station that has the following characteristics:

- Usage of low cost equipment
- Flexible data-handling to use the data for different purpose
- Sensors should be as accurate as possible
- Wireless connection to get the data from different sensors and to make the set up as easy as possible
- A possible number of at least 6 different stations per central station to make a comparison possible

The present paper describes the development of a wireless weather station measuring temperature, humidity, pressure and ligintensity

II. THE IMPORTANCE OF ENVIRONMENTAL PARAMETERS

Modern weather forecasts are a result of a computer calculated model, which uses a mesh of weather stations, weather balloons and satellites around the world. Based on the actual conditions and long time datasets it is possible to make a relative correct outlook for the next few days. The data of the sensors have to be exact with the lowest accuracy possible to get an exact forecast [4]. Additional to the accuracy the number of stations has to be very high so that the mesh cells are very small. Modern forecast systems use a resolution of one station per 32km [5]. A lower resolution is difficult to produce, because the costs per weather station are very high. But to improve the simulations a smaller grid size would be necessary [6].

The weather data is also necessary of other purposes. For example in agriculture it is necessary to

know the past and actual conditions on the fields to plan the use of fertilizer, aerial spraying, watering or harvest or in zoology, the population of insects and bigger animals is directly corresponding to the former weather condition which makes these data necessary for research and fight against upcoming pests [7].

III. MEASUREMENT OF ENVIRONMENTAL PARAMETERS

There are several important values to be measured. The most important weather element is the temperature. It is an element to which human life, and also plant and animal life is sensitive. The temperature is measured by different types of thermometers classified in four groups:

- x Liquid in glass thermometers
- x Deformation thermometers
- x Liquid in metal thermometers
- x Electrical thermometers

For an automatic weather station only the electrical thermometers can be used because all of the other thermometers need personal to read the temperature from the scale.

The second value to be measured is the pressure. The pressure is measured in kPa and is a value of the weight of the air above the sensor. As a result of the air's constant and complex movements and the changes in its temperature and its water vapour content, the weight of the air above a fixed point is continually changing. Therefore the pressure is never constant for long and is an important feature of the weather by reason of the relations to other weather changes. The instrument to get the air pressure is a Barometer.

Barometers can be divided in 3 groups:

- x Mercury Barometers
- x Aneroid Barometers
- x Digital Barometers

For an automatic weather station again only the digital instrument can be used. Because the pressure is addicted to different environmental conditions four corrections are necessary to make a barometer reading comparable with other readings of other places [8].

Temperature correction – as a convention all pressure readings are scaled to 0°C

1. Gravity correction – the force of gravity varies over

the earth's surface because the earth is not a perfect sphere (the equatorial diameter is 43km greater than its polar diameter).

2. Instrumental error correction – like all sensors, even barometers have an internal error, which has to be corrected by comparing the value with the exact value given by a reference.
3. Altitude correction –all barometer readings are reduced to sea-level for the purpose of comparison

In New Zealand the error caused by the gravity-differences is minimal so that if the measurement is correct only a temperature and an altitude correction are necessary.

The most variable gas in the atmosphere is the water vapour, measured by the humidity. For zero up to 4% of the volume is water. It's extremely important to man's existence on the earth and constitutes one of the primary elements of weather. It not only contributes to the heating and cooling of the earth's surface but is directly related to the distribution and extent of precipitation over the earth .

There are different ways to make the amount of water in the air comparable. The first is to measure the absolute Humidity that means the actual mass of water vapour in a given volume of air, for example 3 grams of water in a cubic meter of air. The second and most common way is the Relative Humidity. It is the percentage of water vapour present in the air comparison with saturation conditions. Relative humidity UR (in per cent) of moist air is defined:

Where r is the actual amount of water vapour in the air and r_w the maximum capacity of vapour the air can hold, before it starts to condensate. This factor depends on the temperature. If the relative humidity reaches 100% the air is saturated with water and some of the water vapour becomes liquid, this is also called the Dew Point. Almost all weather aspects can be traced back to the amount of solar radiation that reaches the surface of the earth. Therefore the sunlight should be measured as well. The light intensity changes with the seasons. In the summer is the time with the highest amount because the sun has its greatest noon elevation.

The sunlight can be measured in different ways. One way is to measure the energy brought by the sun to a specific area on the earth-surface, on all wavelength (in W/m²) and the other way is to get the intensity of illumination for a specific wavelength (in lux). In this paper the light according to the visual perception (the illumination) is measured.

IV. DEVELOPED SYSTEM

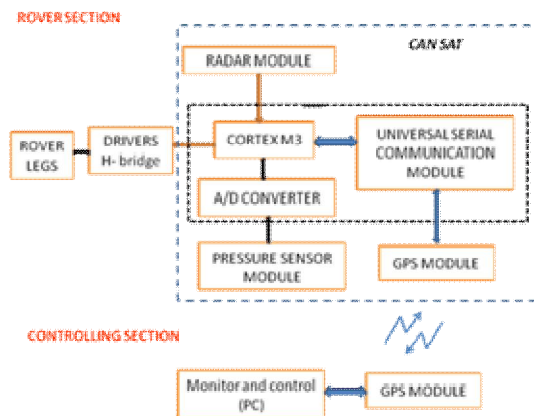

The developed system is based on a cortex-M3, communicating with a central station (Figure 2). The cortex-M3 is connected to different sensors, which giving analog voltage signals. These signals are measured and “translated” into the responding value. All of these values are send trough the XBee Module to a base station, which stores the data into an Access Database. The Values can then be displayed in the GUI running on a computer.

4.1. Temperature Measurement

The temperature, as the most important weather info can be measured in different ways. There electrical sensors with different type of measurement, such as change of resistance or thermo elements. There are also integrated circuits, which give different output signals, such as serial data or analog values.

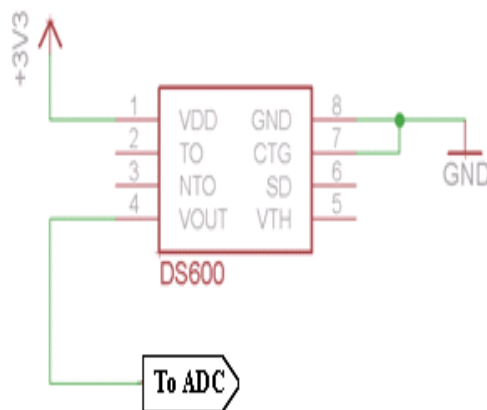

Figure 3: Circuit of temperature sensor DS600

The temperature in this project is measured with an integrated circuit, the DS600 temperature sensor produced by MAXIM - Dallas Semiconductor. The Sensor gives an analog output depending on the measured temperature. This voltage has to be measured by the microcontroller using a 12bit Analog-to-Digital converter (ADC). The IC has an accuracy of $\pm 0.5^{\circ}\text{C}$ and a linear output with $6.45\text{mV}/^{\circ}\text{C}$ and an offset of 509mV (Figure)[11].

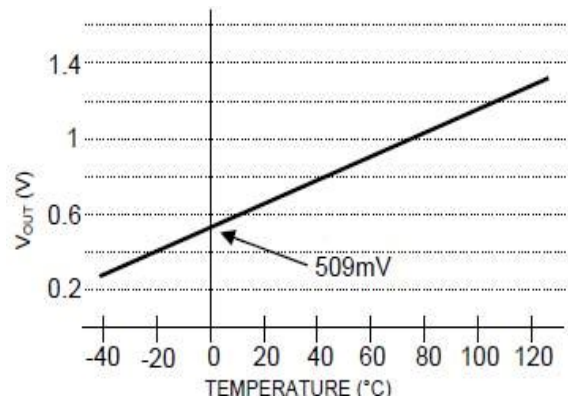

Figure 4: DS600 Output characteristic

4.2. Humidity Measurement

The Humidity is measured with and integrated circuit, the HIH-4010 produced by Honeywell International Inc. Like the temperature sensor, the Humidity sensor gives an analog output, which is measured by the 12Bit ADC of the C8051F020 (Figure).

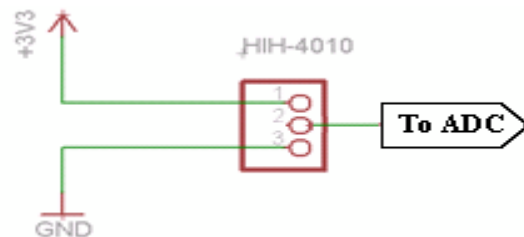

Figure 6: Humidity measuring circuit

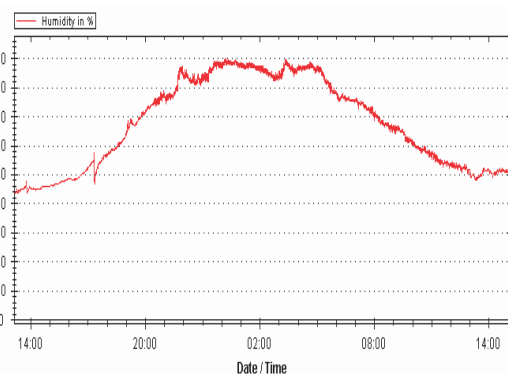

Figure 7: Daily Humidity change captured with HIH-4010

4.3. Light Intensity Measurement

A value which is very important for the development of plants and which influences the well-being of human beings is the light-strength. For that purpose a light measurement circuit (Figure 8) with a Photodiode has been used to measure the light intensity. The photo diode BPW21 has a color-correction filter, giving an approximation to the spectral response of the human eye [13]. A value which is very important for the

development of plants and which influences the well-being of human beings is the light-strength. For that purpose a light measurement circuit (Figure 8) with a Photodiode has been used to measure the light intensity. The photo diode BPW21 has a color-correction filter, giving an approximation to the spectral response of the human eye [13].

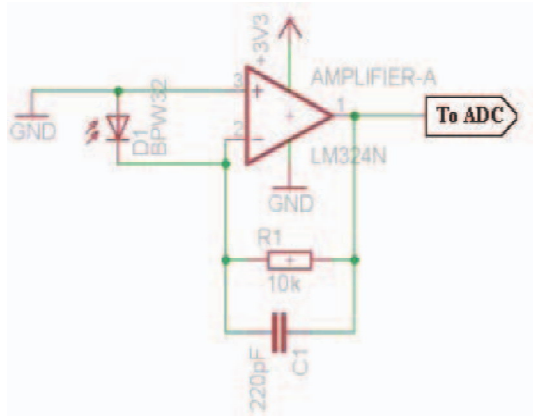

Figure 8: Light measurement circuit

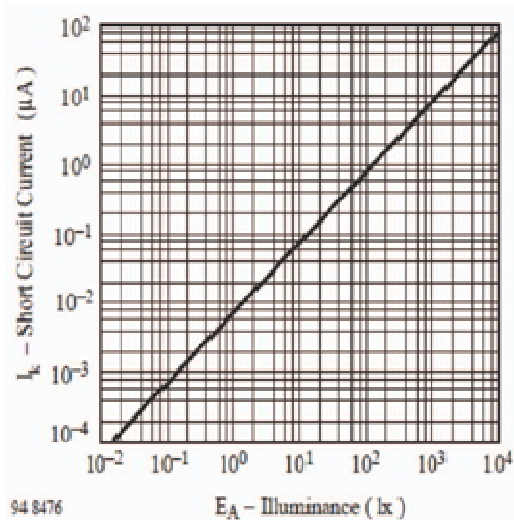

Figure 9. Short Circuit Current vs. Illuminance

The daily change of the light intensity can be seen in Figure 10

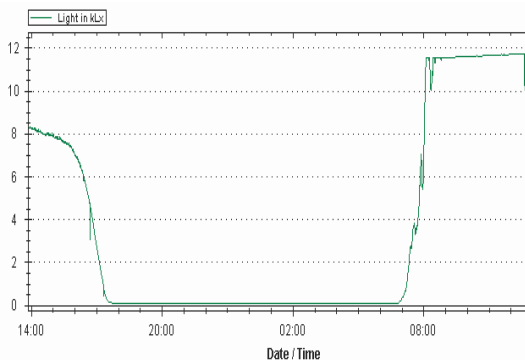

Figure 10: Daily light intensity captured with BPW21

4.4. Pressure Measurement

The weather is directly connected to the air-pressure. Low pressure is associated with bad weather and a rapid change of the pressure means a drastic change in weather, for example and upcoming storm can be forecasted by looking at the last hours of pressure measurement.

The Pressure was measured with the integrated circuit MPX-4100 build by Motorola. The used circuit can be seen in Figure 11. The circuit needs a 5V power supply and the output to the ADC is between 0 and 5 V what makes a voltage divider necessary.

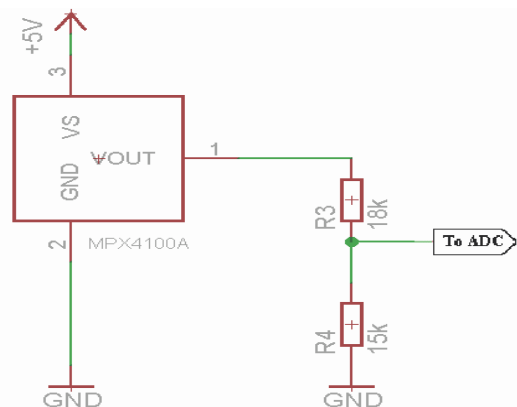

Figure 11: Pressure measurement circuit

4.5. Communication

To save the data measured by the sensors it was necessary to build a network between the sensors and to set up a computer receiving and storing the values. For the communication ZigBee modules were used. These provide a wide range and a couple of low power modes, which could be used to reduce the current consumption of the circuit. In addition the network-setup is easy and fast, so that an extension of new Stations is possible without problems.

V. OUTCOME AND ANALYSIS

Six prototype weather stations have been fabricated and successfully tested over more than 24 hours. The weather data captured by the sensors correspond directly to the data that are given by non-electrical sensing elements, like thermometers, barometers and hygrometers.

The data show, that there are some problems to be solved, for example is the humidity and the pressuresensor very sensitive to direct sunshine, so that a casing is needed that is impervious to light. For the correctness of the data is necessary that the position of the sensor is chosen well. The Influence of for example machines which expose heat has to be reduced.

The sensors consume less than 10mA while measuring. The biggest amount of energy is used for the wireless communication (35mA while sending). The usage of the XBee module sleep mode and reducing the communication time is essential to reduce power consumption. Nonetheless a battery powered weather station can be build. The usage of solar or wind-turbine power is also conceivable.

- [4] Beniston, Martin. *From Turbulence to Climate: Numerical Investigations of the Atmosphere with a Hierarchy of Models*. Berlin: Springer, 1998.
- [5] Kalnay, Eugenia. *Atmospheric Modeling, Data Assimilation and Predictability*. Cambridge: Cambridge University Press, 2003.
- [6] Pielke, Roger A. *Mesoscale meteorological modeling*. San Diego: Academic Press, 2002.

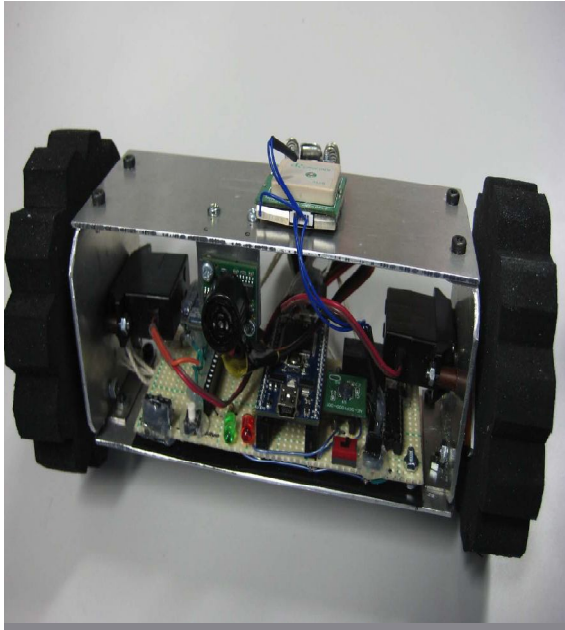

DESIGN OF THE UNIVERSITY LEVEL CANSAT

I. CONCLUSION AND FUTURE WORK

In this paper we have propose a environmental monitoring system with a mesh network structure controlled by a central station. The different stations are equipped with temperature-, relative humidity-, pressure- and sunlight-sensors. Initial component testing of sensor performance has reflected good results in sensing and radio communication. The outcome provides a variable platform for different sensors to measure necessary values. Further development on downsizing the system, using alternative energy sources and analysis of the measured data is scheduled next.

REFERENCES

- [1] Farrand, John. *Weather*. New York, 1990.
- [2] Columbia-Weather. "Pegasus EX Portable Weather Station - Columbia Weather Systems, Inc." [http://www.columbiaweather.com/Pegasus EX-Brochure.pdf](http://www.columbiaweather.com/Pegasus%20EX-Brochure.pdf) (accessed June 3, 2010).
- [3] Irox. "Irox - Produkte - PRO-X2 USB." http://www.irox.com/data_access/irox/dowloads/bedienungsanleitungen/PRO_X2_e.pdf (accessed June 3, 2010).