

January 2014

## DESIGN & ANALYSIS OF FLY BACK CONVERTER FOR GRID & FILAMENT POWER SUPPLIES OF TRAVELLING WAVE TUBE

SUNIL KUMAR. M

R.V.C.E Bangalore, sunil08615@gmail.com

S. G. SRIVANI

R.V.C.E Bangalore, srivani.sg@gmail.com

VENKATESH PRABHU

DRDO, Bangalore, ve\_prabhu@yahoo.com

Follow this and additional works at: <https://www.interscience.in/ijpsoem>



Part of the [Power and Energy Commons](#)

---

### Recommended Citation

M, SUNIL KUMAR.; SRIVANI, S. G.; and PRABHU, VENKATESH (2014) "DESIGN & ANALYSIS OF FLY BACK CONVERTER FOR GRID & FILAMENT POWER SUPPLIES OF TRAVELLING WAVE TUBE," *International Journal of Power System Operation and Energy Management*. Vol. 3 : Iss. 1 , Article 7.

DOI: 10.47893/IJPSOEM.2014.1115

Available at: <https://www.interscience.in/ijpsoem/vol3/iss1/7>

This Article is brought to you for free and open access by the Interscience Journals at Interscience Research Network. It has been accepted for inclusion in International Journal of Power System Operation and Energy Management by an authorized editor of Interscience Research Network. For more information, please contact [sritampatnaik@gmail.com](mailto:sritampatnaik@gmail.com).

# DESIGN & ANALYSIS OF FLY BACK CONVERTER FOR GRID & FILAMENT POWER SUPPLIES OF TRAVELLING WAVE TUBE

SUNIL KUMAR. M<sup>1</sup>, S. G. SRIVANI<sup>2</sup> & VENKATESH PRABHU<sup>3</sup>

<sup>1&2</sup>Department of Electrical and Electronics Engineering (Power Electronics), R.V.C.E Bangalore

<sup>3</sup>Scientist 'D', 'B' Radar, LRDE, DRDO, Bangalore

E-mail : <sup>1</sup>sunil08615@gmail.com, <sup>2</sup>srivani.sg@gmail.com, <sup>3</sup>ve\_prabhu@yahoo.com

---

**Abstract** - In High Power Pulsed Radar Transmitters the gridded TWT are used and consists of floating deck modulator unit which houses the Grid and Filament power supplies. The Grid Control includes the Grid Positive & Grid Negative Power Supplies. The Positive voltage is used to turn on the TWT & Negative voltage is used to operate the TWT in off state. The Filament power supply heats the cathode to required temperature to emit electrons. The aim of the project is to design the Grid power supplies and Filament Power supply based on the Fly back Converter topology which is operated at 100 KHz in DCM mode and CCM mode respectively. The Pulse width modulation technique is used to maintain the voltage at desired value using an IC UC1526. The switching device is protected against over currents by pulse to pulse current limiting using current transformer and current limit comparator of uc1526.

**Keywords** - RADAR, TWT, FLYBACK Converter, pulse width modulator, Grid filament, DCM (Discontinuous current mode), CCM (Continuous current mode).

---

## I. INTRODUCTION

Transmitter in radar applications, use microwave tubes for the purpose of amplifying RF signals from few milliwatts to several kilowatts. This amplification is performed by the microwave tubes like Crossfield amplifiers, Klystrons, TWT's etc. All these microwave tubes amplify the RF signal by proper interaction between electron beam and RF field, in such a way that electron beam energy is converted into RF field energy to generate necessary electron beam energy high/low voltage floating supplies are used. These supplies include high frequency converter topologies to get improved performance and to realize in compact size, also these power supplies needed to be regulated precisely to meet requirements of spectral purity. Filament, grid bias for cut-off, grid pulse supply and focus supply. It is essential to design these supplies using high frequency converter topologies to get improved performance and to realize in compact size, also these power supplies needed to be regulated precisely to meet requirements of spectral purity.

## II. RADAR

The term RADAR stands for *RA*dio *DE*tecting *AN*d *RA*nging. Radar is the primary sensor on nearly all military aircraft. Radar radiates electromagnetic energy from an antenna to propagate in space. Some of the radiated energy is intercepted by a reflecting object usually called a target, located at a distance from the Radar. The energy intercepted by the target is reradiated in many directions. Some of the reradiated which called an echo is returned and received by the Radar antenna. Thus Radio waves were

utilized to detect the presence of a target and determine its distance or range. Other roles include airborne early warning, target acquisition, target tracking, target illumination, ground mapping, collision avoidance, altimeter, weather warning. Practical frequency range 100MHz-100GHz. The velocity of the electromagnetic waves radiated from the Radar in free space is approximately 1000ft/μsec. Therefore if the object is on nautical mile away (6080ft) it will take slightly more than 12 μsec for the transmitted energy to reach the target and return. The radar transmitter subsystem uses a microwave tubes for the purpose of amplifying the signal from few milliWatts to several kilowatts. This amplification is performed by the microwave tubes like Cross field amplifier, Klystrons and TWT (Traveling Wave tube).

## III. TRAVELING WAVE TUBE

A traveling wave tube (TWT) which is shown in Fig 1.1 is a device that is used to create high power radio frequency (RF) signals. The injected RF signal into a TWT travels along a helical transmission line inside vacuum tube waveguide, which allows the signal's electromagnetic fields to interact with an electron beam that passes through the center of the coil. This interaction amplifies the input signal. TWTs have been designed to operate for frequencies as low as 500MHz and as high as 300 GHz. They are used extensively in satellite communication and airborne radar systems.

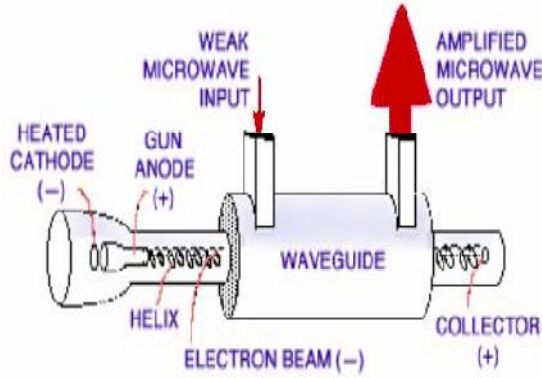

Fig. 1 : Structure of Traveling Wave Tube

**IV. FLYBACK CONVETER**

A flyback converter is a switching power supply topology widely used in applications that require power below IOOW.

A basic flyback converter, comprising of a power MOSFET, diode, capacitor, and transformer, is shown in Fig. 2. A gapped transformer provides electrical isolation between input and output as well as store energy (in the air-gap). When the MOSFET is turned on, the primary current flows, while the diode is reverse biased preventing a flow of secondary current. During this MOSFET’s turn on period, energy is stored in the transformer with a load current being supplied by the output capacitor. When the MOSFET is tuned off, the primary current ceases to conduct. The collapsing magnetic field in the transformer causes a polarity of the secondary voltage to reverse. The diode is now forward biased enabling a flow of secondary current. During this turn off period, energy stored in the transformer is released to the output capacitor and load.

Various aspects of the flyback converter and design are mentioned in [1]. A flyback converter can be designed to operate in CCM or DCM.

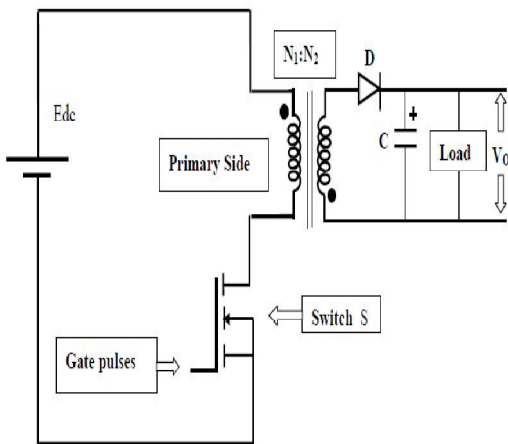

Fig. 2 : Flyback Converter

**GRID & FILAMENT POWER SUPPLIES**

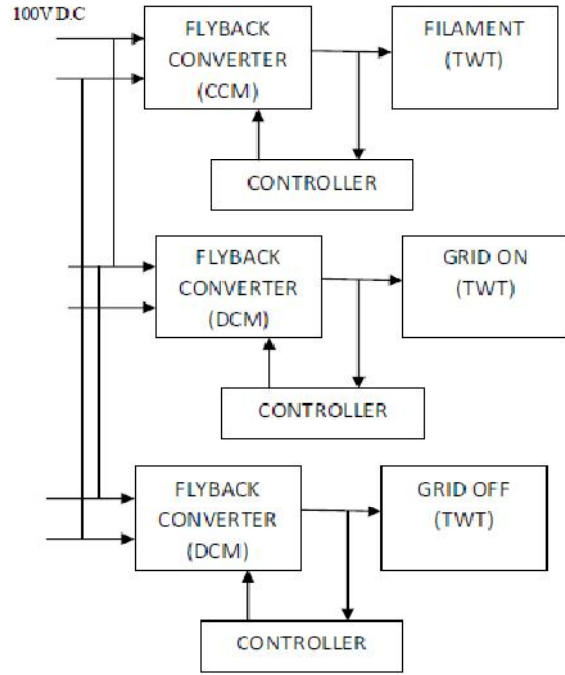

Fig. 3 : Block diagram of Grid & filament power supplies

The Grid power supplies includes Positive Grid & Negative Grid supplies which are used to control the output of the TWT. The Positive Grid Supply is used to switch on the TWT & Negative Grid supply is used to switch of the TWT. In Fig.3. An input of 100V is fed to Flyback Converter that uses the MOSFET switch, operating at 100 KHz. The duty cycle of switch is varied to obtain the required output voltage. The Fly back converter is operated in DCM mode. The fly back transformer provides the adjustment output voltage as required by the TWT .

The filament power supply is realized using a flyback converter topology which operates in CCM Mode . The continuous power supply is maintained at filament which heats the cathode to required temperature to emit electrons.

**V. POWER SUPPLY DESIGN**

*A. Transformer Design*

**Positive Grid supply design :**

Output voltage -  $V_o = 400V-700V$  (adjustable)

Switching freq,  $f = 100$  kHz

Supply voltage -  $V_{in} = 100 \pm 5\%$

Power rating = 14 W

Core used – Pot core.

**Negative Grid supply design :**

Output voltage -  $V_o = 450V-550V$  (adjustable)

Switching freq,  $f = 100$  kHz

Supply voltage -  $V_{in} = 100 \pm 5\%$

Power rating = 5.5 W

Core used – Pot core

**Filament supply design :**

Output voltage -  $V_o = 8V-10V$  (adjustable)

Switching freq,  $f = 100$  kHz

Supply voltage -  $V_{in} = 100 \pm 5\%$

Power rating = 90 W

Core used – Pot core

**B. PWM Controllers**

The selection of PWM controller IC is based on outputs required and the maximum duty cycle operation, switching frequency ,the peak current of the output based on this the UC1526 is selected.The UC1526 is a high performance pulse width modulator integrated circuit intended for fixed frequency switching regulators and other power control applications.

**C. Features of UC1526**

- To 35V Operation
- V Reference Trimmed To  $\square$  1%
- 1Hz To 400kHz Oscillator Range
- Dual 100mA Source/Sink Outputs
- Digital Current Limiting
- Double Pulse Suppression
- Programmable Deadtime
- Under-Voltage Lockout
- Programmable Soft-Start
- Wide Current Limit Common Mode Range

**VI. SIMULATIONS AND RESULTS**

SPICE is a general purpose circuit program that simulates electronic circuits.In this project, OrCAD PSpice 9 and 16.3 versions are used and Matlab software is used to design compensation circuit.

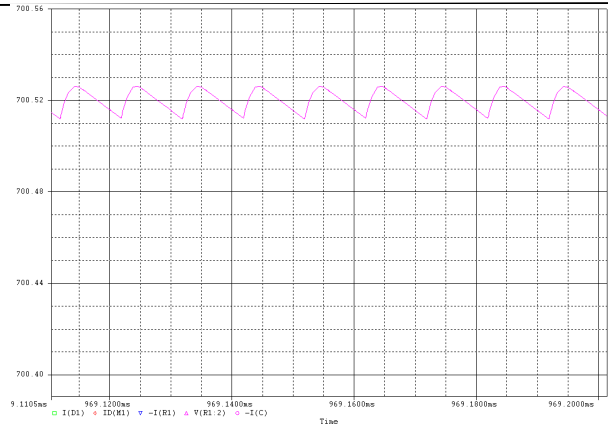

**Fig. 5.a. Output voltage  $V_o=700V$**

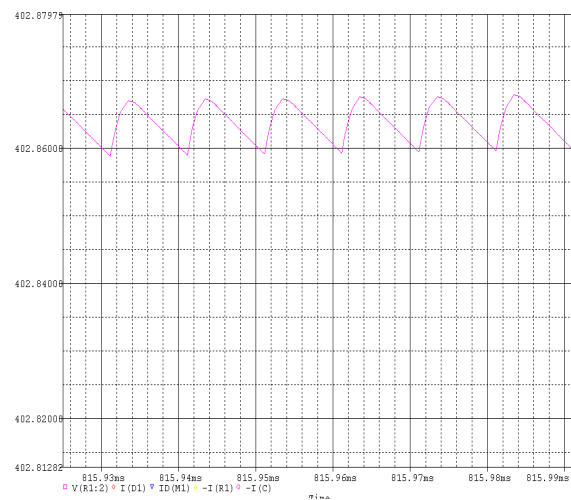

**Fig. 5.b : Output voltage  $V_o=400V$**

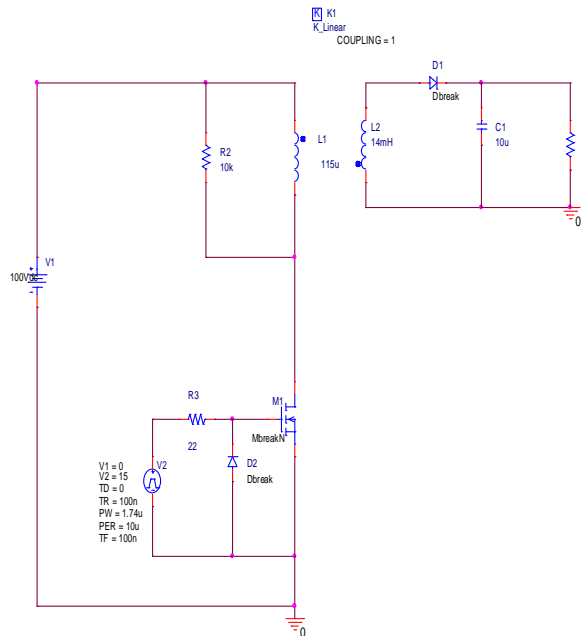

**Fig. 5: Circuit diagram for Positive Grid supply**

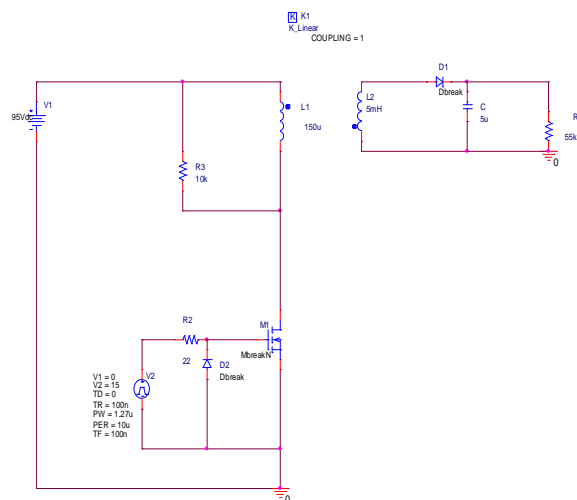

**Fig. 6 : Circuit diagram for Negative Grid supply**

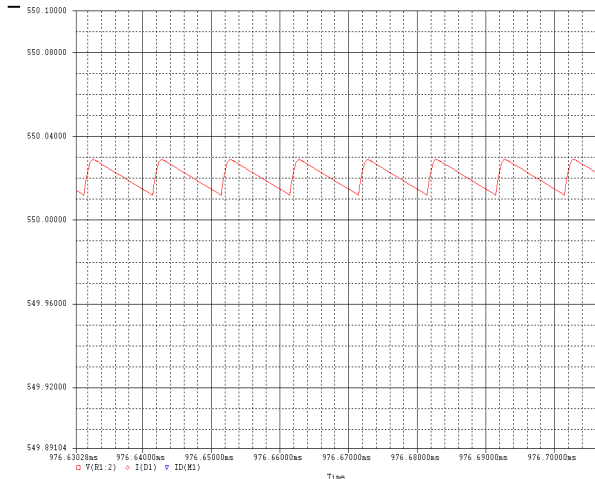

Fig. 6.a : Output voltage  $V_o=550V$

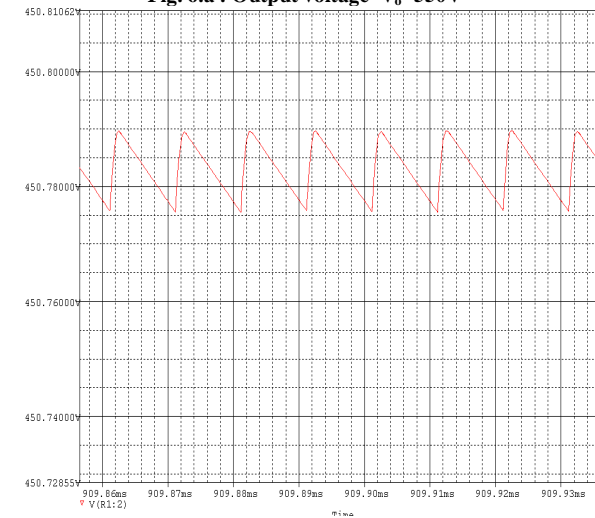

Fig. 6.b. Output voltage  $V_o=450V$

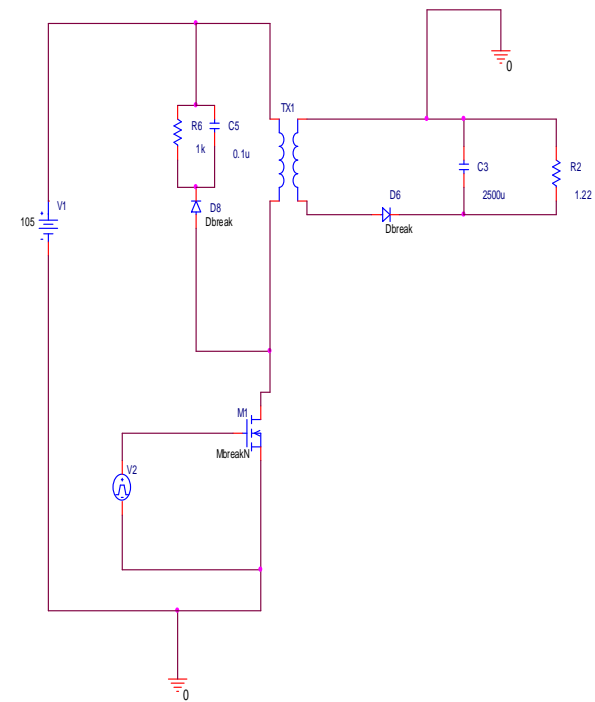

Fig. 7 : Circuit diagram for filament supply

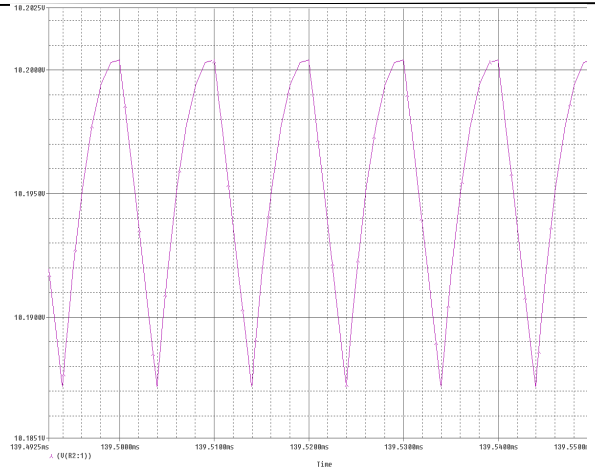

Fig. 7.a. output voltage  $V_o=10V$

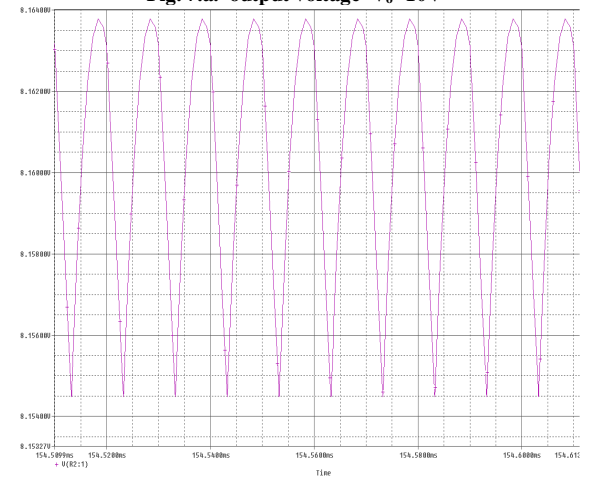

Fig. 7.b : Output voltage  $V_o=8V$

**A. FEEDBACK LOOP COMPENSATION**

**Bode plot for Positive Grid system**

The T.F of Flyback Converter [2] in DCM

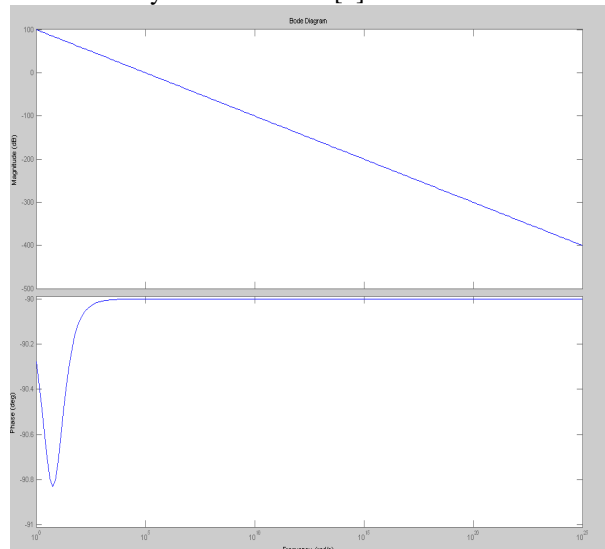

Fig. 8 : Bode plot for Positive Grid system

Results:

PM=INF , BW=15Khz,GM=90

**Bode plot for Negative Grid system**

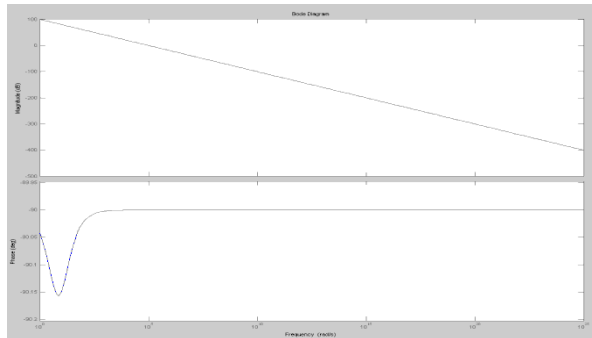

Fig. 9 : Bode plot for Negative Grid system

Results:

PM=INF , BW=15Khz,GM=90

**Bode plot for filament Power supply**

The T.F of Flyback Converter [2] in CCM

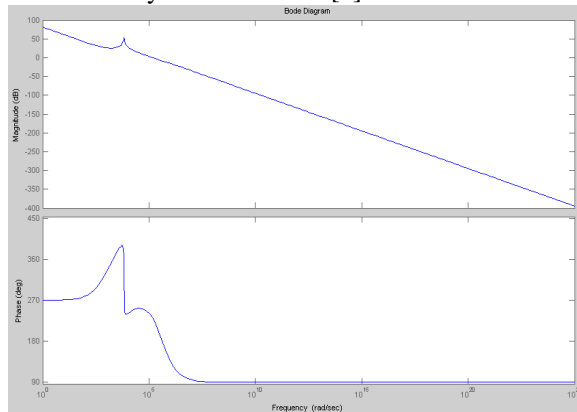

Fig.10 : Bode plot for filament Power supply

Results:

GM=2.7993 PM =52.4276 BW = 21Khz

**VII. CONCLUSION**

The fly back converter topology is best suited for application less than 100W. The TWT requirements are met with the selected topology. The increase in switching frequency and use of pot core has resulted in the reduction in size and weight of SMPS.

**ACKNOWLEDGEMENTS**

First of all, I would like to thank Dr.R.Jayapal , HOD, EEE Dept.RVCE, Bangalore, providing right academic environment and valuable guide lines.

It is a matter of immense pleasure to express sincere thanks to Mr. Venkatesh Prabhu Scientist ‘D’, B-Radar,LRDE, DRDO,for accepting me as a project trainee under his supervision and guidance.

I thank Mrs. Dr.S.G.Srivani, Associate Professor,EEE Dept. RVCE, for her continuous support and guidance.

**REFERENCES**

- [1] I. Pressman, “Switching power supply design”. McGraw-Hill.
- [2] Switched Mode Power Conversion by V. Ramanarayanan ,IISC Bangalore.
- [3] Performance comparison of continuous conduction mode (CCM)and discontinuous conduction mode (DCM) fly back converters,” in Proc. IEEE Power Electronics and Drive Systems Conf.,

