

# International Journal of Power System Operation and Energy Management

---

Volume 2 | Issue 3

Article 3

---

July 2013

## INTELLIGENT SCADA FOR LOAD CONTROL

S. R. KATKAR

*G. H. Raison College of Engg. Digdoh Hill, Hingna Road, Nagpur-440016 (M.S.), India,*  
suhas\_5324@yahoo.co.in

S. V. UMREDKAR

*An Autonomous Institute Under UGC Act 1956 affiliated by RT M, Nagpur University, Nagpur,*  
sheetal.umredkar@gmail.com

Follow this and additional works at: <https://www.interscience.in/ijpsoem>



Part of the [Power and Energy Commons](#)

---

### Recommended Citation

KATKAR, S. R. and UMREDKAR, S. V. (2013) "INTELLIGENT SCADA FOR LOAD CONTROL," *International Journal of Power System Operation and Energy Management*. Vol. 2 : Iss. 3 , Article 3.

DOI: 10.47893/IJPSOEM.2013.1081

Available at: <https://www.interscience.in/ijpsoem/vol2/iss3/3>

This Article is brought to you for free and open access by the Interscience Journals at Interscience Research Network. It has been accepted for inclusion in International Journal of Power System Operation and Energy Management by an authorized editor of Interscience Research Network. For more information, please contact [sritampatnaik@gmail.com](mailto:sritampatnaik@gmail.com).

# INTELLIGENT SCADA FOR LOAD CONTROL

S. R. KATKAR<sup>1</sup> & S. V. UMREDKAR<sup>2</sup>

<sup>1</sup>G. H. Raisoni College of Engg. Digdoh Hill, Hingna Road, Nagpur-440016 (M.S.), India

<sup>2</sup>Electrical Engineering Department, An Autonomous Institute Under UGC Act 1956 affiliated by RT M,  
Nagpur University, Nagpur

E-mail: Suhas\_5324@yahoo.co.in., sheetal.umredkar@gmail.com

---

**Abstract** - This paper presents the use of intelligent system with Supervisory control and data acquisition system (SCADA) Software and hardware components platform like PLC considered as the main contents of this project. SCADA software enables us to monitor, record data whenever required from the hardware installed and gives the status of the main power system components like motors, relays, panels, feeders, furnaces, etc. Feature of the design intends load control, distribution and history readings. A small hardware model shows the conveyer application which interface with SCADA and PLC. The application implemented on ladder logic simulation with KGL\_WE simulator and SCADA helps to shows real time information about the system.

**Keywords** - Human machine Interface, Intelligent control, SCADA and PLC.

---

## I. INTRODUCTION

Supervisory Control and Data Acquisition (SCADA) systems play an important rule for a reliable and secure operation of power systems. A traditional power system is characterized by large power plants installed far from the consumption centers. Real time information about the system state is required for a reliable and secure operation of the power system. [1].

With SCADA systems, information about power system can be acquired and commands can be sent to power system components, such as power plants and substations. The developments in software and hardware have enabled one to perform a real time remote control and monitoring of nowadays complex power systems for operators to accomplish their tasks.

The traditional power system structure is changing with more and more competitive business environment. In face of these challenges the operators need to change their control/operation strategies adopting more flexible methodologies and the SCADA system should evolve to a more decentralized and flexible structure [2]. This new SCADA system would require a hierarchical structure to control all points of the power system, giving multiple controls for different networks operators. Distributed decision making and a multiplicity are required in this new context. Only a flexible SCADA system can make possible an adequate coordination of control operation. Human Machine Interface (HMI) software needs to be adapted to the new SCADA structure [3]. The application described in this paper is a Smart Home tool that controls an industrial conveyor, using an intelligent individual SCADA system to control power equipments. The management system considers an envisaged set point,

defined according to the real time context. Alternatively, the set point can also be manually set by the user.

When the load is lower than this set point, there is no place to set the load management. When the set point is lower than the load, the main objective is to keep the power consumption close to the set point, by reducing or turning off loads, respecting a priori defined rules. Recent studies have proved that loads are not rigid, exhibiting elasticity that can be used for mutual benefits of power system and consumers. Demand response should be considered as an energy resource that can be used, together with other energy resources (generation, network, storage) to optimize power system operation. This is especially important in the situation when there is a shortage of resources such as incident situations. Power system components are important because of:

- a) The relevance of their physical existence and operation features.
- b) The availability of relevant information we may have about them in decision centers ( LDCs);
- c) The permission to operate them.

The relevance of one specific component for the solution of a particular problem must be evaluated considering simultaneously [4].

After this introduction section, this paper is organized as follows: Section II deals with Basic structure of SCADA systems; Section III describes the devices in SCADA system; Section IV presents a intelligent SCAD for industrial purpose; Section V gives idea about proposed hardware system; VI Simulations; and finally, Section VII presents the conclusions.

## II. BASIC STRUCTURE OF A SCADA SYSTEM

In order to increase the flexibility of the SCADA systems, it is important to isolate subsystems which are influenced by changes of environments. Therefore, programs in electric power systems falls into three hierarchical layers as shown in Figure 1. Interfaces between different layers encapsulate the inner-structure of each layer; therefore, the modification of programs and data in one layer does not affect other layers [5].

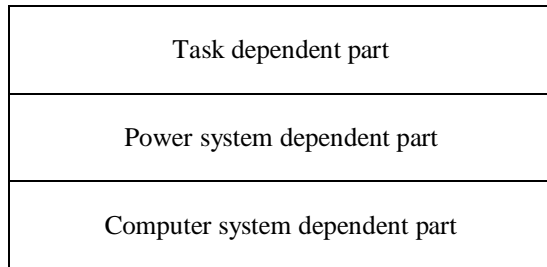

Fig. 1 : Three Layers of SCADA System

Monitoring of nowadays complex power systems and enable operators to accomplish their tasks. The traditional power system structure is changing with more and a more competitive business environment. In face of these challenges the operators need to change their control/operation strategies adopting more flexible methodologies and the SCADA system.

**Task Dependent Part :** Programs and data in this part are independent of the configuration of both power systems and computer systems. Since the programs in this layer become general package software independent of system configuration, they can be used in all offices with minimum modification. Namely, their modifications are needed only when application specification is changed.

**Power System Dependent Part :** This part encapsulates the hardware configuration and operational organization of real power system, and provides two abstract data models. One corresponds to hardware of power systems, such as a topology of transmission lines, circuit-breakers and transformers. The other corresponds to operational organization of power system, such as office configuration, control areas and ordering authority. These models make programs of the task dependent part independent of real power system Configuration.

**Computer Dependent Part :** This part hides a computer system configuration. It encapsulates network topology of computer system, computer architecture, location of resources etc., and the programs and data of upper two layers can be developed without awareness of computer environments.

## III. DEVICES IN SCADA SYSTEM

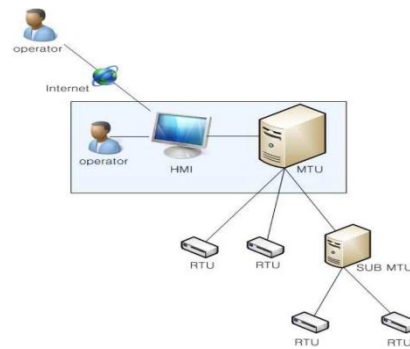

Fig. 2: Devices In SCADA System

A SCADA system usually consists of a number of different devices.

RTU makes them physically insecure, so the RTUs should be protected from tampering [6].

1) **HMI (Human Machine Interface) :** The operator interacts with the system through the HMI. The HMI usually supports graphic interface. The HMI for the SCADA systems has been developed to utilize a wide range of client technologies, including desktop PCs [6].

## IV. INTELLIGENT SCADA

Making the new paradigm possible requires decision decentralization and the adequate means to implement it. This is certainly not the case of current SCADA systems. These are intended for the monitoring and supervision of equipments owned (or at least operated) by a very limited number of entities (one in most cases). It is assumed that there is a fixed entity to operate each piece of equipment (there is of course flexibility to operate at different levels, such as locally or remotely, but in the scope of the same entity such as a distribution or transmission company). In the future DER owned by a large set of diverse entities will represent a significant part of the overall resources. It is not possible to adequately plan and operate the system if DER are not considered as taking part in the solution of power system problems. For this, it is required to have decentralized intelligence and decision ability. It is equally important to have SCADA based on a power system model which is based on the new paradigm. This imposes to consider both the physical part of each power system component and its cyber dimension, which requires a SCADA based on a cyber-physical model of the power system. Power system components are important because of:

- the relevance of their physical existence and operation features (P);
- the availability of relevant information we may have about them in decision centers (I);
- the permission to operate them (O).

The relevance of one specific component for the solution of a particular problem must be evaluated considering simultaneously a), b) and c). In fact, it is not at all relevant to have a component with the adequate characteristics to in the current state of art; SCADA systems consider these three conditions in a very limited way, using the logic of serving a single entity that uses each SCADA. In the future, SCADA will have to consider the same three conditions in the scope of competitive environments where each entity SCADA has direct access to its own components. When negotiated, each SCADA can also have access to information and operation of other players owned components. Moreover, in many cases, once these permissions, and the conditions under which they should become active, are define are, the permission should be automatic and transparent to the users. Like this, real-time operation is guaranteed and market and ownership issues are respected. solve a problem if one does not have access to the required information about it in due time to take a decision. None of these is of any value if one does not have the permission to operate this component. Some characteristics of SCADA systems presently Commercialized can be pointed out [7]:

- Today's SCADA systems are able to take advantage of the evolution from mainframe based to client/server architectures. These systems use common communications protocols like Ethernet and TCP/IP to transmit data from the field to the central master control unit;
- SCADA protocols have evolved from closed proprietary systems to an open system, allowing designers to choose equipment that can help them monitor their system using equipments from a variety of vendors;
- SCADA systems are widely used to monitor and control critical infrastructure utilities;
- While SCADA protocols are more open today, there is not yet a clear consensus of which protocol is the best.

The main advantages of using SCADA systems in a company are [8]:

- Real-time monitoring,
- System modifications,
- Troubleshooting,
- Increased equipment life,
- Automatic report generating, etc.

## V. PROPOSE HARDWARE SYSTEM

This proposes hardware consist of following parts:

1. Motors (M1, M2, M3, & M4)
2. Conveyor belt
3. Robotic arm
4. Trolley
5. Mechanical gears
6. Furnace
7. Sensors
8. Thermostat

9. PLC
10. SCADA
11. Panel



Fig. 3 : Relay Panel And Conveyor With Robotic Arm

When temperature of furnace reach to the set point of thermostat (S1), it will send signal to PLC and plc turn on motor M1 due to this conveyor start to moving that carries trolley with material as well as motor M2 turn and it set initial position using three sensors (S4, S6 & S8). Now when trolley reach to sensor point, sensor(S2) sense it and send back signal to plc and motor M3 operates i.e upwards and downwards movement with some time delay also motor M4 operates. M3 & M4 use for robotic arm picks the material from the trolley and when picks the material that time sensor (S9) send signal to plc, robotic arm operates to unhold the material into the furnace but robotic gear is made up of plastic, protection from heat, here use sensor(S5) for limit level. Already furnace temperature set point reach to set point so melt the material in a furnace for this we set a delay time. Now operate M4 to forward and sensor (S3) send signal to plc and motor M2 operate and return to its initial position when S3 operates that time M5 also operate to tilt the furnace and molted metal pour into the buckets of different size and shapes and again this whole processes repeated. This all process control by using PLC with SCADA to control, monitor, it is fully automated processes. The plc as a simply switching device and SCADA use for monitoring purpose. When this hardware communicates with plc and SCADA that time real time status of information about field devices display, which indicates the motor on/off status and conveyor system with actual running process on/off status. But we use plc it is digital DI's & DO's, so trends indicates only low and high signals. For robotic arm alarm buzzer used to safe and secure operation will suddenly stop the whole process of system if any

instruction occurs. This whole process is based on a automation scheme. Basic layout of hardware design with motors and sensors are as show in figure 4.

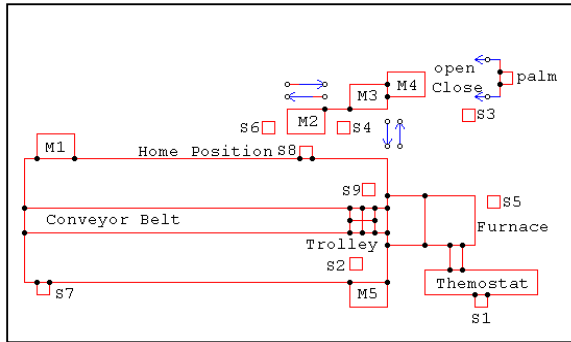

Fig. 4 : Basic Layout of Hardware Design

VI. SIMULATION

A. SIMULATION OF LADDER PROGRAMING  
 We studied the three types of plc like Siemens, Schneider, and LG. After comparatively study we decide to use of LG PLC with KGL\_WE simulator. Because this PLC MODBUS protocol supported and it is easy to communicate with SCADA. Also it required RS 232 or serial cable. Proposed hardware system totally based on automation in which all field devices running according to ladder logic for this using KGL\_WE simulator.

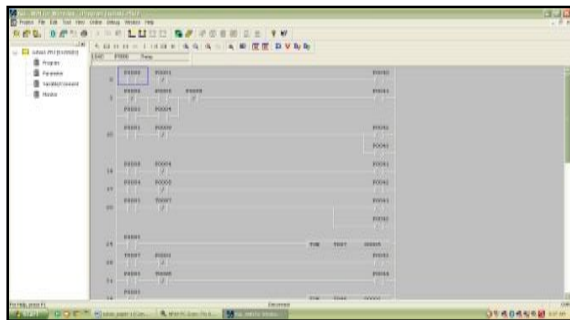

Fig. 5 : Ladder Logic Diagram

The ladder logic see in fig 4 download in PLC after that all field devices inputs and outputs connected to the PLC. In Kgl\_We a best feature is it gives a on-line or off-line simulation, if hardware not connected that time we test the ladder logic by off-line simulation mode. The on-line simulation step show in fig 6.

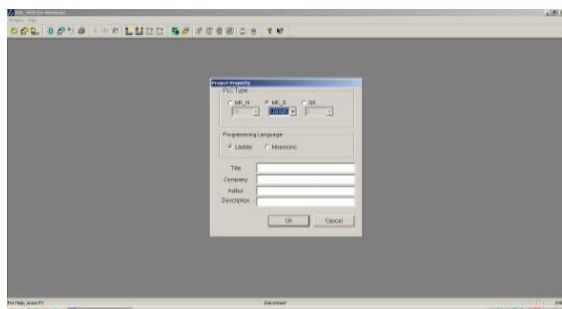

Fig. 6 : Select Simulation Using KGL\_WE

B. SIMULATION ON ICONICS SOFTWARE  
 We studied the three types of SCADA like iFIX, InTouch and ICONICS. After comparatively study we decide to use ICONICS SCADA software. Because ICONICS SCADA is supports different PLC, it does not required particular drivers for communication with PLC.

For SCADA use the ICONIC software in which we see the real time information of proposed system even if we observe fault at which place in system occur means monitoring whole system operation at control room. Real time status of field devices shows in fig 7.

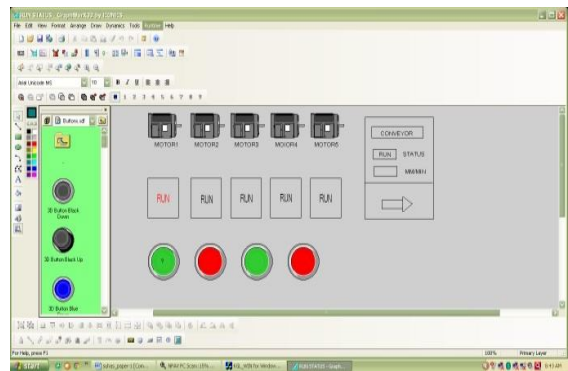

Fig. 7: Real Time Status of Field Devices on SCADA

VII. RESULT

The proposed system is designed for industrial automation, So that we can save the power of different Heavy Electrical Equipments (e.g. Conveyors, Furnaces, Motors, etc) also controls the operations and monitoring the real time information of field devices in the system.

VIII. CONCLUSION

This paper presents a load management application for use in industrial installations. The presented application is implemented in ICONICS and KGL\_WE simulator software.

- A supervisory control and data acquisition (SCADA) system is an integrated platform that incorporates several components.
- It has been applied in the field of power system and several engineering applications to monitor, operate, and control a lot of processes.
- To study how efficiently we can use SCADA system to control and monitor the Load Distribution Schemes.
- The proposed work having Hardware and software Optimization with the help of PLC Ladder Logic. We are adopting this technique to reach strong Conclusion about their actual impact on the power Consumption.

---

**REFERENCES**

- [1] Swamp, K.S., Mahesh, p.u.; "Computerized data acquisition for power system automation", Power India Conference, 2006 IEEE, pp. 486-492, 2006.
- [2] Vale, Z., Morais, H., Silva, M., Ramos, c., "Towards a future SCADA", Power & Energy Society General Meeting, 2009, PES'09, pp.1-7, 26-30 July 2009.
- [3] Seki, T., SaJo, H., Tanaka, T., WaJanabe, H., "Decentralized autonomous object-oriented EMS/SCADA system", Autonomous Decentralized Systems, 1997, Proceedings, ISADS 97, Third International Symposium, pp. 395-402, 9-11 April 1997.
- [4] Vale, Z., Morais, H., Faria, P., Ferreira, J., "Emergency Energy Resources Management in Smart Grid", CRIS 2010, Beijing, China, 20 – 22 September, 2010
- [5] Seki, T., SaJo, H., Tanaka, T., WaJanabe, H., "Decentralized autonomous object-oriented EMS/SCADA system", Autonomous Decentralized Systems, 1997, Proceedings, ISADS 97, Third International Symposium, pp. 395-402, 9-11 April 1997.
- [6] D. Robert, B. Colin, D. Ed, and M. G. N. Juan, "SKMA a key management architecture for SCADA systems," in Proc. 4<sup>th</sup> Australasian Information Security Workshop, 2006, vol. 54, pp 138-192.
- [7] Zita Vale, H. Morais, M. Cardoso, C. Ramos, H. Khodr, "Distributed Generation Producers' Reserve Management", IEEE PES General Meeting, Pittsburgh, USA, July 20-24, 2008.
- [8] Randy Dennison (2007), "A Pre-SCADA System Assessment", pp.1

