

January 2013

VOLT-SECOND BALANCE METHOD FOR MITIGATION OF INRUSH CURRENT IN SINGLE PHASE TRANSFORMERS

D P Balachandran

College of Engineering, Trivandrum, Kerala, India, dpbchandran@yahoo.co.in

R SREERAMA Kumar

National Institute of Technology, Calicut Kerala, India, sreeram@nitc.ac.in

Follow this and additional works at: <https://www.interscience.in/ijpsoem>



Part of the [Power and Energy Commons](#)

Recommended Citation

Balachandran, D P and Kumar, R SREERAMA (2013) "VOLT-SECOND BALANCE METHOD FOR MITIGATION OF INRUSH CURRENT IN SINGLE PHASE TRANSFORMERS," *International Journal of Power System Operation and Energy Management*. Vol. 2 : Iss. 1 , Article 14.

DOI: 10.47893/IJPSOEM.2013.1063

Available at: <https://www.interscience.in/ijpsoem/vol2/iss1/14>

This Article is brought to you for free and open access by the Interscience Journals at Interscience Research Network. It has been accepted for inclusion in International Journal of Power System Operation and Energy Management by an authorized editor of Interscience Research Network. For more information, please contact sritampatnaik@gmail.com.

VOLT-SECOND BALANCE METHOD FOR MITIGATION OF INRUSH CURRENT IN SINGLE PHASE TRANSFORMERS

¹D P BALACHANDRAN, ²R SREERAMA KUMAR & ³B JAYANAND

¹College of Engineering, Trivandrum, Kerala, India, ²National Institute of Technology, Calicut Kerala, India

³Govt. Engineering College, Thrissur, Kerala, India

E-mail : dpbchandran@yahoo.co.in¹, sreeram@nitc.ac.in²

Abstract - During the transient period at the start of transformer energization, it experiences a flux linkage that is up to twice its nominal steady state value and saturates the core. This causes a large inrush current to flow which affects the power system stability and power quality especially when the source is weak. Sequential phase energization technique and addition of neutral resistor are the major methods for minimization of inrush current. This paper proposes a simple technique to limit the flux linkage during the time of transformer energization and prevents the flux saturation there by reducing the inrush current. This is based on a volt-second balance which injects a transient voltage to the primary of the transformer during inrush currents. The effectiveness of the proposed scheme is verified by simulation.

Keywords - Inrush current, flux compensation, volt-second balance, voltage injection.

I. INTRODUCTION

Transformer energization on no load results magnetizing inrush currents which is several times the nominal load current and last for a few cycles. The time taken by the inrush current to decay depends on the time constant of the transformer and the circuit parameters. Time constant of the transformer is not constant; the value of inductance changes depending on the extent of core saturation. During the first few cycles saturation is high and inductance is low. Hence the initial current and the rate of decay of current are high. As the resistance of the circuit damps and saturation drops, inductance increases slowing down the decay. Hence the decay of inrush current starts with a high initial rate and progressively reduces. The transient magnetizing inrush current of the switched-in transformer also flows into other transformers and produce in them a dc flux which gets superimposed on their normal ac flux [1].

The asymmetrical high magnitude inrush currents contain odd and even harmonics and a slowly decaying dc component. The high magnitude of inrush current may result in the advertent operation of the overload and differential relays, tripping the transformer out of the circuit as soon as it is switched on. The presence of harmonics may lead to resonance causing temporary over voltages. The other undesirable effects of inrush currents are oscillatory torque in motors, increased mechanical and insulation failure. The magnitude and

polarity of inrush current depends on several factors such as the reactive power demand in transformers causing voltage sag problems point on the voltage waveform at which transformer is energized, the residual flux building polarity and over excitation.

Several methods have been proposed for eliminating inrush current in transformers. Over sizing of transformer at more than rated flux density is one approach to avoid the inrush current. But this will increase the size and weight of the transformer. Re-energization of a transformer exactly at an instant of a voltage wave which corresponds to the actual flux density in the core at that instant, it would result in no inrush current [1]. Sequential energization of each phase with a grounding resistor connected at the transformer neutral reduces inrush current [2], [3], [4]. Elimination of inrush current is achieved by controlled transformer switching by taking into account the core flux and residual core flux in the closing control algorithm [5],[6]. However in practice the instant of switching cannot be easily controlled. In [7] the authors present a technique based on the use of a virtual air gap. A non-synchronous suppressing method is proposed in [8] to suppress the inrush current of phase transformers. Inrush currents in coupling transformers of voltage sag compensators are mitigated by controlling the injection voltage [9]. A thyristor controlled series compensator in transmission lines mitigates the impact of transformer inrush current by decreasing the source reactance [10].

In [11] a circuit breaker control strategy without independent pole operation and residual flux estimation has been reported for reducing inrush current. An active method of the series compensator used for reduction of inrush current is explained in [12]. A method based on voltage injection to the tertiary winding of power transformers prior to primary side energization has been explained in [13]. This paper proposes a new method for minimizing the inrush current in transformers by injecting a compensatory current into the load transformer which compensates the additional flux built by the dc

component of the inrush current and preventing saturation of core flux. The compensating current supplied by the series compensator has opposite polarity to the inrush current produced by the load transformer.

II. PHYSICAL PHENOMINA AND THEORY

When a transformer is re-energized by a voltage source, the flux linkage must match the voltage change according to Faraday’s law,

$$V_m \sin(\omega t + \theta) = i_o R + N \frac{d\Phi_m}{dt} \tag{1}$$

where ,

- V_m - peak value of the applied voltage
- θ - angle at which voltage is switched on
- i_o - instantaneous value of magnetizing current
- Φ_m - instantaneous value of flux
- R - primary winding resistance
- N - primary winding turns

The solution of the equation assuming linear magnetic characteristics (1) is,

$$\Phi_m = (\Phi_{mp} \cos\theta \pm \Phi_r) e^{-\frac{R}{L}t} - (\Phi_{mp} \cos(\omega t + \theta)) \tag{2}$$

- where, Φ_{mp} - peak flux
- Φ_r - residual flux

The flux waveform given by equation (2) shows that the first component is a flux wave of transient dc component, which decays at a rate determined by the ratio of resistance to inductance of primary winding (R/L), and a steady-state ac component. This dc component drives the core strongly into saturation which is accompanied by flux unbalance and drop in inductance. The rate at which current in a coil increases is inversely proportional to the inductance and is given by

$$I = V * t / L^1 \tag{3}$$

- where, I - rms value of current
- V - rms value of voltage
- t - time in seconds
- L^1 - non linear inductance

Any drop in inductance therefore causes the current to raise faster, increasing the field strength and driving the core even further into saturation causing flux unbalance. The basic principle of the proposed inrush current minimization technique is to prevent the flux from exceeding the predetermined maximum flux (Φ_{mp}), and to keep the inductance of the transformer in steady state preventing the inrush current.

The expression for flux density in a transformer core is

$$B = (V \times t) / (N \times Ae) \tag{4}$$

where B - flux density in Tesla

Ae - cross sectional area of core in m^2

Examination of this expression reveals that core flux is a function of the applied volt-second and the physical characteristics of the magnetic design. Flux unbalance means volt-seconds unbalance. So flux balance is achieved by making volt-seconds balance by injecting a transient voltage to the transformer.

III. PROPOSED INRUSH CURRENT MITIGATION SCHEME

The simplified single line block diagram of the proposed inrush current mitigation technique is shown in Fig.1. The system consists of a pulse transformer connected in series with the primary winding of the load transformer for injecting the compensating flux (volt-second) into the load transformer. GTO1 and GTO2 are anti- parallel connected gate turn off switches connected across the pulse transformer. For an offline compensator system, the pulse transformer is bypassed by the GTO switches when the transformer grid current is normal. The inrush current detector detects the presence of inrush current and generates a mono pulse of short duration which opens GTO1 or GTO2 and closes thyristor T1/T2.

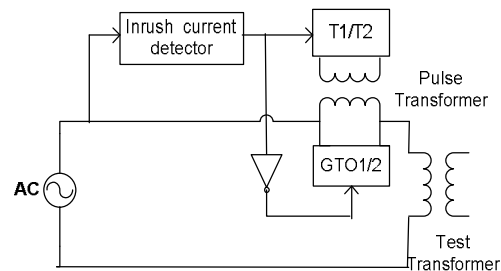

Fig. 1 : Simplified one-line diagram of the inrush current compensator

When switch GTO1/GTO2 is opened the inrush current is transferred to the pulse transformer and due to the high rate of change of current a high voltage is induced across the pulse transformer. The polarity of the induced voltage is in opposition to the primary voltage of the load transformer. This phenomenon is equivalent to injecting a flux (volt-second) into the transformer core, thus preventing flux saturation and mitigating inrush current. The magnitude of voltage induced in the pulse transformer depends on the inductance, rate of change of current and the flux. The induced voltage is limited by limiting the flux in the pulse transformer, by short circuiting the secondary of the pulse transformer by switching the anti parallel connected thyristors T1/T2. The selection of switching of T1/T2 depends on the polarity of the voltage induced on the secondary winding of pulse transformer, which in turn depends on the direction of inrush current. The polarity of

inrush current is found from the polarity of dc component present in the transformer current through Fast Fourier Transform (FFT) analysis.

The flow chart of the control system of the inrush current compensator is shown in Fig.2. The controller uses the magnitude of instantaneous power for identifying inrush current from faults and other load currents. The method of detecting inrush current from faults and other load currents is based on the different behavior of the instantaneous power. The instantaneous power due to inrush current comprises of both positive and negative varying values which is exponentially decaying. For faults and load currents the instantaneous power is only positive or less negative. This feature of instantaneous power is used to distinguish the inrush current from other currents. The inputs to the multiplier are $v(t)$ and $i(t)$ and it computes the value of instantaneous power $p(t)$.

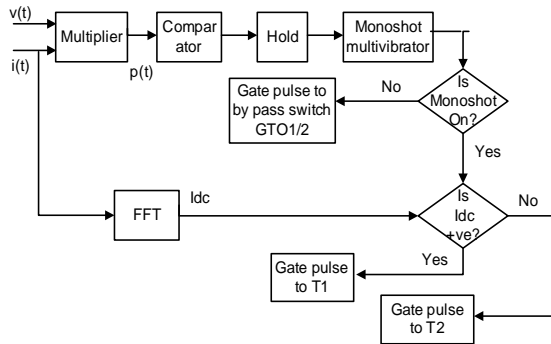

Fig. 2 : Control diagram of inrush current compensator

A comparator detects the negative value of instantaneous power, compares with a threshold value and if the threshold value is high, it generates a high digital output. This digital output is used to generate a mono shot pulse of required width which triggers the GTO1/GTO2. If the dc component of inrush current is positive, it triggers thyristor T1 and if it is negative, it triggers T2. The threshold value is the negative of the maximum instantaneous power for a transformer during inrush current which is predetermined.

IV. SIMULATION RESULTS

The effectiveness of the proposed technique is investigated by simulation on a single phase 230V/230V, 1kVA 50 Hz transformer using PSCAD. The test transformer is switched on at various inception angles against positive residual flux of 0.8pu. Residual flux is incorporated by connecting a current source in parallel with primary winding of the load transformer. Fig.3 shows the variation of inrush current and flux for a switching instant of 0.1s (0^0). First plot shows the inrush current; second plot flux and the third plot dc component. Simulations are carried for different switching angles. Table I summarizes the peak values of inrush current, flux, dc component and settling time for different switching angles. Fig.4 shows the plot of inrush current,

instantaneous power and inrush current detection signal (output of monoshot). Next the inrush current mitigation technique is applied and the transformer is again energized at different switching angles. Fig.5 shows the plot of inrush current, flux and dc

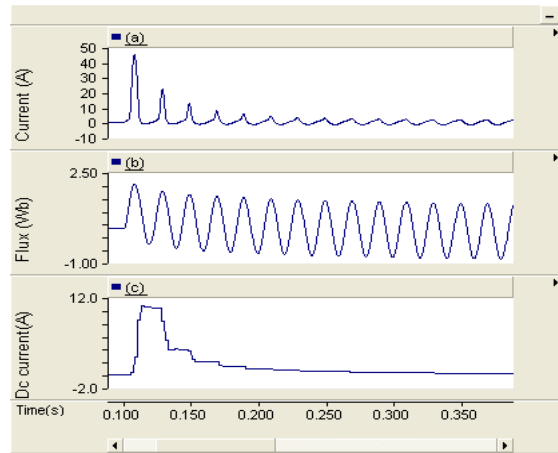

Fig. 3 : Transformer energization at switching angle 0^0 (a) Inrush current (b) Flux (c) DC component

TABLE I

PARAMETERS AT 0.8PU POSITIVE RESIDUAL FLUX BEFORE COMPENSATION

| Switching angle | 0^0 | 90^0 | 180^0 | 270^0 |
|-------------------|-----------------|--------|---------|---------|
| Peak current(A) | 1 st | 45 | 2.7 | -20 |
| | 2 nd | 26 | 1.2 | -2.9 |
| Peak DC (A) | | 11.2 | 0.14 | -3.4 |
| Peak Flux (pu) | 1 st | 2.03 | 1.31 | -1.7 |
| | 2 nd | 1.76 | 1.29 | -1.35 |
| Settling time (s) | | 0.9 | 1 | 0.9 |

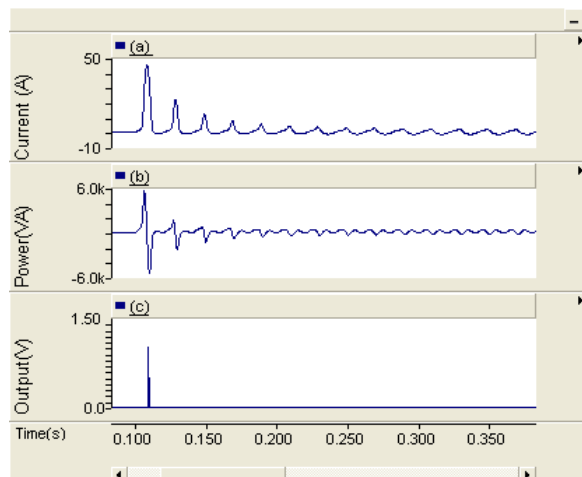

Fig. 4 : Transformer energization at switching angle 0^0 (a) Inrush current (b) Instantaneous power (c) Inrush current detection signal

component after applying the compensating technique at a switching angle of 0^0 . Simulations are carried for different switching angles and the results are tabulated in Table 2. The graphs shows that the first and second

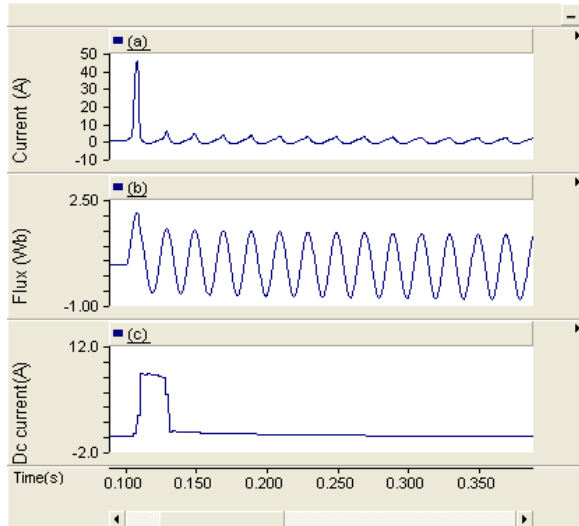

Fig. 5 : Transformer energization with compensator at switching angle 0° (a) Inrush current (b) Flux (c) DC component

peak of the inrush current are 45A and 26A respectively before compensation and the current settling time is 0.9s. After the compensation there is no change in the first peak value. However second peak of inrush current is reduced to 2.4A and the settling time is reduced to 0.01s. Before compensation the value of first peak flux is 2.03pu which is highly unbalanced. After the voltage injection, there is no reduction flux for the first peak. However the second peak of flux reduced to 1.1pu from 1.76pu and flux balance is achieved at 0.11s. After the compensation the peak dc component is also reduced from 11A to 8.2A. As the inrush current is detected after first half cycle of energization, the dc component present is compensated within 0.01s after switching.

TABLE 2

PARAMETERS AT 0.8PU POSITIVE RESIDUAL FLUX AFTER COMPENSATION

| Switching Angle | | 0° | 90° | 180° | 270° |
|-------------------|-----------------|-----------|------------|-------------|-------------|
| Peak current(A) | 1 st | 45 | 2.7 | -9.4 | 30 |
| | 2 nd | 2.4 | 1.2 | -2.9 | 5.3 |
| Peak DC (A) | | 8.2 | 0.14 | -3.4 | 5 |
| Peak Flux (pu) | 1 st | 2.03 | 1.31 | -1.7 | 1.8 |
| | 2 nd | 1.1 | 1.29 | -1.4 | 1.5 |
| Settling time (s) | | 0.01 | 0.01 | 0.01 | 0.01 |

The transition of primary current of the load transformer from GTO1 to the primary of pulse transformer during compensation is shown in Fig.6. The first plot shows the load transformer energization current through GTO1. Second plot the change over current from GTO1 to pulse transformer and third plot the transformer primary current. Transit time taken is 1ms. Due to this high rate of change of current the voltage induced in the primary winding of

pulse transformer is 1748V and peak voltage induced in the primary of load transformer is 1846V. This peak voltage is limited by short circuiting the secondary of

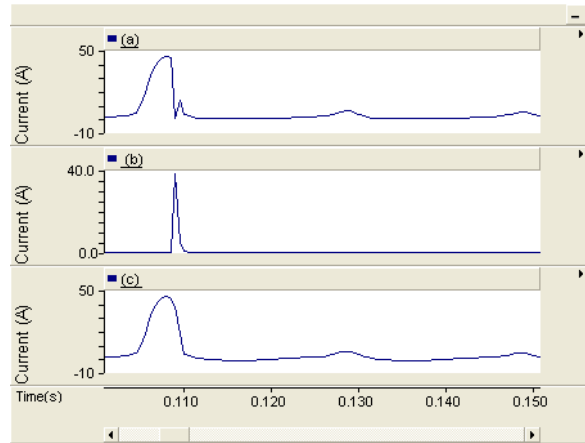

Fig. 6 : Current through a) GTO1 b) Pulse transformer c) Load transformer

the pulse transformer. The voltage seen on the primary winding and secondary winding of load transformer is 890V and 938V respectively. Fig.7 shows the variation of voltage injected by the pulse transformer and voltage on the primary side of load transformer.

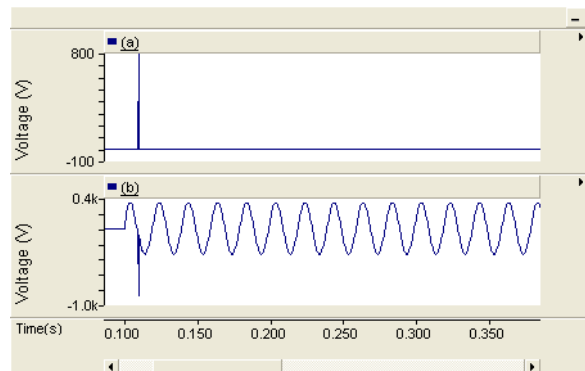

Fig. 7 : Voltage during compensation a) Pulse transformer primary b) Load transformer primary .

The flux (volt-second) injected into the load transformer core is 0.89 Wb (890V*0.001s). The peak voltage seen by the load transformer is large and since it is for a very short duration (1ms) this does not affect the power transformer performance

V. CONCLUSION

In this paper a passive cost effective method of series compensator for mitigation of inrush current in transformers during start up mode has been proposed. The proposed scheme aims at balancing flux (volt-second) asymmetry in the core during inrush current by injecting a voltage into the primary winding of load transformer through a series connected pulse transformer. The circuit for the series voltage

injection and a technique to limit the injected voltage has been also proposed. This strategy on the basis of the voltage injection is quite different from present approaches of inrush current reduction. This control strategy is easy to implement because the series compensator is effective in reduction of the startup inrush current for all power-on angles without prior measurement on residual flux in transformer core. The simulation investigations reveal that the proposed approach reduces inrush current in single phase transformers. This is achieved without any complicated hardware that too without the need for a separate source.

REFERENCES

- [1] S.V. Kulkarni and S.A Khaparde, Transformer Engineering: Design and Practice. New York: Marcel Dekker, 2004.
- [2] Yu Cui , Sami G Abdulsalam, Shiuming Chen and Wilsun Xu "A Sequential Phase Energization Technique for Transformer Inrush Current Reduction – Part I : Simulation and Experimental Results" IEEE Transactions on Power Delivery, Vol.20 , No.2, pp 943-949, April. 2005
- [3] Wilsun Xu , Sami G Abdulsalam , Yu Cui and Xian Liu "A Sequential Phase Energization Technique for Transformer Inrush Current Reduction – Part II : Theoretical Analysis and Design Guide" IEEE Transactions on Power Delivery, Vol.20, No.2 , pp 950-957, April. 2005
- [4] T Haryono and Mursid Sabdullah " Simulation Study of Transformer Inrush Current and Mitigation Method" Proceedings of the international Conference on Electrical Engineering and Informatics, Institute of Technology Bandung, Indonesia, pp 262-265 June 17-19, 2007
- [5] John H Brunke and Klaus J Frohlich "Elimination of Transformer Inrush Currents by Controlled Switching –Part I : Theoretical Considerations" IEEE Transactions on Power Deliver, Vol.16 , No.2 , pp 276-280, April. 2001
- [6] John H Brunke and Klaus J Frohlich "Elimination of Transformer Inrush Currents by Controlled Switching –Part II : Application and Performance Considerations" IEEE Transactions on Power Delivery , Vol.16 , No.2 , pp 281-285, April. 2001
- [7] Vincent Molcrette, Jean-Luc Kotny, Jean-Paul Swan and Jean-Francois Brudny "Reduction of inrush current in single phase Transformer using virtual air gap technique" IEEE Transactions on Magnetics, Vol 34, No4 , pp 1192-1194, July 1998
- [8] C L Cheng, C E Lin, K C Hu and Y F Hasia "Effective suppression method of three-phase transformer's inrush current "Proceedings of IEEE TENCON 2002, pp 2030-2033.
- [9] Po-Tai Cheng , Wei-Ting Chen , Yu-Hsing Chen , Chia-Long Ni and Jarsun Lin " A Transformer Inrush Mitigation Method For Series Voltage Sag Compensators" IEEE Transactions on Power Electronics, Vol.22 , No.5 , pp 1890-1899, Sep. 2007
- [10] Mojtaba Khederzadeh "Mitigation of the impact of transformer inrush current on voltage sag by TCSC" Electric Power System Research Vol 80, issue 9, pp1049-1055, Sept 2010.
- [11] Nicola Chiesa and Hans Kristian Hoidalén " Novel Approach for Reducing Transformer Inrush Currents: Laboratory Measurements, Analytical Interpretation and Simulation studies" IEEE Transactions on Power Delivery,, Vol.25, No.4 , pp 2609-2616, Oct. 2010.
- [12] Juei-Lung Shyu "A novel control strategy to reduce transformer inrush currents by series compensator" IEEE PEDS 2005, pp 1283-1288
- [13] Balachandran D P, Sreerama Kumar R and Shimnamol V P "A new technique for mitigation of transformer inrush current" CIRED 2007, Vienna 21-24 May 2007.
- [14] Chris Fitzer Atputharajh Arulampalam, Mike Barnes and Rainer Zurowski "Mitigation of saturation in dynamic voltage restorer connection transformers" IEEE Transactions on Power Electronics, Vol.17 No.6, pp 1058-1065 Nov. 2002.

