

International Journal of Power System Operation and Energy Management

Volume 2 | Issue 1

Article 1

January 2013

A Review of Optimized Heating Performance of Induction Cookers

Madichetty Sreedhar

School of Electrical Engineering , KIIT University, Bhubaneswar, madichettysreedhar@gmail.com

Follow this and additional works at: <https://www.interscience.in/ijpsoem>



Part of the [Power and Energy Commons](#)

Recommended Citation

Sreedhar, Madichetty (2013) "A Review of Optimized Heating Performance of Induction Cookers," *International Journal of Power System Operation and Energy Management*: Vol. 2 : Iss. 1 , Article 1.

DOI: 10.47893/IJPSOEM.2013.1050

Available at: <https://www.interscience.in/ijpsoem/vol2/iss1/1>

This Article is brought to you for free and open access by the Interscience Journals at Interscience Research Network. It has been accepted for inclusion in International Journal of Power System Operation and Energy Management by an authorized editor of Interscience Research Network. For more information, please contact sritampatnaik@gmail.com.

A Review of Optimized Heating Performance of Induction Cookers

Madichetty Sreedhar & Abhijit Dasgupta

School of Electrical Engineering , KIIT University, Bhubaneswar

Abstract:-This paper presents a review of different types of Induction cooker design which can be used for domestic heating and industrial heating applications. The designs focus on optimized power regulation strategy.

Keywords:-Induction heating, Inverter, Zero voltage switching, Resonant inverter.

I. INTRODUCTION

The traditional way of cooking, is using liquid petroleum gas(LPG) or other bio fuels or electric heaters. It has been proved that the gas burners or traditional electric heaters transfer only 35-40% of its energy to the pan and remaining energy is lost and thus the total efficiency of the cooking system is low. Burning fuel also generates CO₂ and other gases, and this contributes to green house effect, and global warming.

In order to overcome the disadvantages of the traditional cooking process, the energy conversion by using the electromagnetic conversion in induction heating is being used increasingly. The efficiency of the induction cooking may be up to 80-90%.

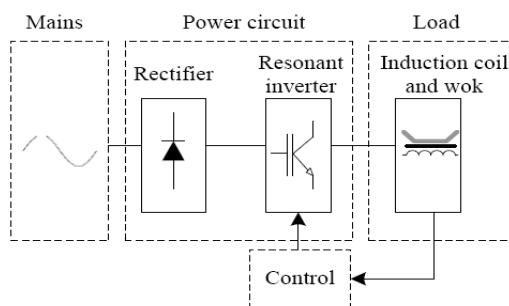

Fig.1 Block Diagram Of Induction Cooker

Fig(1) shows, the block diagram of the induction cooker, which mainly consists of the supply mains, cascaded with rectifier unit, to convert AC-DC and then by using the resonant inverter, the supply is given to the coil of the induction heater.

II. PRINCIPLE OF OPERATION

The thermal performance of an induction cooker system is closely related to the distribution of eddy currents which are directly associated with the amount and location of the heating generation on the induction top.

The basic principle of a transformer is that when current is flowing through the primary winding, flux will be developed, and the flux induces emf in the secondary. Here the secondary side is cooking vessel and the vessel gets heated up.

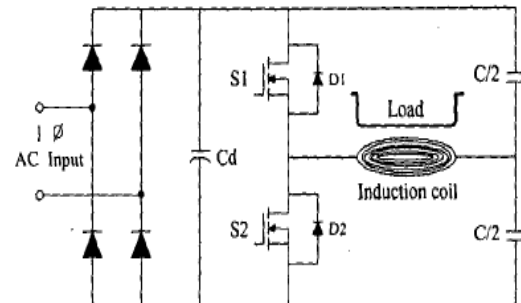

The half bridge series resonant induction cooker consist of two switches with a coil. The input supply is converted in to DC by using rectifier. That output is given to the series resonant inverter, which is switched at very high frequency. Due to reversal of current, eddy currents are produced in the vessel, which produces heat.

There are three power regulation schemes commonly utilized in the popular class-D inverter, which are Pulse Frequency Modulation (PFM) [3]-[5],

Pulse Width Modulation (PWM) [6]-[8], and Pulse Density Modulation (PDM) [9]. Due to smooth regulation and Zero Voltage Switching (ZVS) operation in all load range, PFM is the most preferred in many induction cookers. However, it suffers from the problems of higher frequency loss ratio during light load and thus lower efficiency induced. Although PWM control can ensure the inverter operating at constant switching frequency, the control scheme is rather complicated.

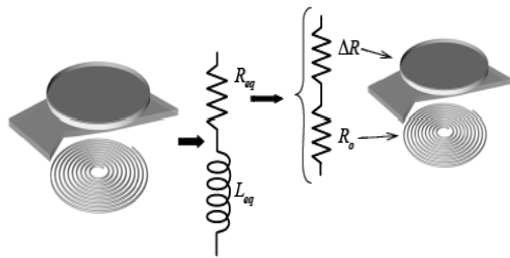

Fig 3. Model of coil and load

The equivalent electrical symbols for the coil is shown in the Fig 3. For phase-shifted PWM control, ZVS is difficult to realize at light load. PDM control strategy proposed by [9] achieves Zero Current Switching (ZCS) and power regulation at constant switching frequency, which is ZCS-PDM control. However, there is a current freewheeling mode during the power regulation in PDM mode [9], which inevitably induces conduction losses of the inverter in this mode. The ZVS-PDM control strategy by realizing ZVS and power regulation at constant switching frequency is proposed by [8], in which the current freewheeling mode is eliminated. However, the discontinuing operation of the inverter, on the other hand, causes lower heating transferring efficiency, especially at high power.

III. DIFFERENT TYPES OF DESIGN

J. Acero, R. Alonso, L.A. Barragan, and J.M. Burdio [2] presents a novel prototype of voltage source soft-switching PWM high frequency inverter with minimum circuit components, which can achieve wider soft commutation, simpler circuit, smaller physical size, lower cost and wider power regulation range, as compared with active voltage clamped edge resonant ZVS. The performances of this quasi-resonant soft switching PWM high frequency inverter operating under principles of ZVS and ZCS related soft commutation is comparatively evaluated.

J.K. Byun, K. Choi, H.S. Roh, and S.Y. Hahn, [1] proposed a systemic design of induction cooker with

convex bottom Chinese wok for commercial applications. Here, On the basis of analyzing the coil characteristics and performance requirements, the overall power structure of the induction cooker is designed with underlying operation principle also explained the control algorithms for the power regulation of the cooker. This scheme proposes an optimized hybrid power regulation strategy.

In order to achieve high electrical and thermal performances, L.A. Barragan, D. Navarro, J. Acero, I. Urriza, J.M. Burdio [3], presents an analysis of high frequency induction cooker, using half-bridge series resonant inverter. This circuit is implemented by using the FPGA implementation, Fig 4. The circuit operation is first analyzed, using the Thevenin equivalent circuit method, which are also verified by experiment, using a prototype cooker of 2 kW 30 kHz with variable power and variable frequency.

F.P. Dawson and P. Jain [4], analyzed the traditional design process and summarized elements in humanized product design, including function, modeling, color, material and interface. The conceptual and embodiment design process of induction cooker was illustrated to show a practical application for humanized product design. The prototype of induction cooker was made by rapid prototype technology.

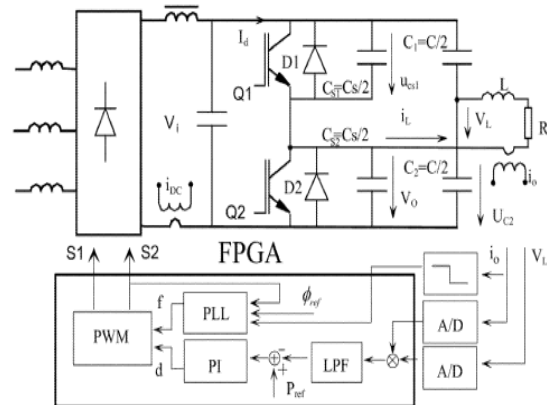

Fig 4. System Configuration by using FPGA implementation

F. Forest, E. Laboure, F. Costa, J. Y. Gaspard [5] Introduces a novel approach for induction heating (IH) design. The powerful particle swarm optimization (PSO) and finite-element method (FEM) are combined together to allow optimal induction heating design. For this purpose cost function is defined as linear combination of leakage flux and electromagnetic forces of induction heating winding. Then using finite-element method, electromagnetic forces and leakage flux is calculated in typical induction cooker in both cases

i.e. conventional and optimized characteristics of induction heating.

REFERENCES:

- [1] J.K. Byun, K. Choi, H.S. Roh, and S.Y. Hahn, —Optimal design procedure for a practical induction heating cooker, □ *IEEE Trans. Magn.*, vol. 36, no. 4, pp. 1390-1393, Jul. 2000.
- [2] J. Acero, R. Alonso, L.A. Barragan, and J.M. Burdio, —Modeling of planar spiral inductors between two multilayer media for induction heating applications, □ *IEEE Trans. Magn.*, vol. 42, no. 11, pp. 3719- 3729, Nov. 2006.
- [3] L.A. Barragan, D. Navarro, J. Acero, I. Urriza, J.M. Burdio, —FPGA implementation of a switching frequency modulation circuit for EMI reduction in resonant inverters for induction heating appliances, □ *IEEE Trans. Ind. Electron.*, vol. 55, no. 1, pp. 11-20, Jan. 2008.
- [4] F.P. Dawson and P. Jain, —A comparison of load commutated inverter systems for induction heating and melting applications, □ *IEEE Trans. Power Electron.*, vol. 6, no. 3, pp. 430-441, Jul. 1991.
- [5] F. Forest, E. Laboure, F. Costa, J. Y. Gaspard, —Principle of a multiload/single converter system for low power induction heating, □ *IEEE Trans. on Power Electron.*, vol. 15, no. 2, pp. 223–230, 2000.
- [6] S. Wang, K. Izaki, I. Hirota, H. Yamashita, H. Omori, M. Nakaoka, —Induction-heated cooking appliance using new quasi-resonant ZVS-PWM inverter with power factor correction, □ *IEEE Trans. Ind. Appl.*, vol. 34, no. 4, pp. 705-712, Jul. /Aug. 1998.
- [7] P. Viriya, N. Yongyuth, and K. Matsuse, —Analysis of two continuous control regions of conventional phase shift and transition phase shift for induction heating inverter under ZVS and NON-ZVS Operation, □ *IEEE Trans. Power Electron.*, vol. 23, no. 6, pp. 2794-2805, Nov. 2008.
- [8] Y. Lu, K.W.E. Cheng, and S.L. Ho, —Quasi current mode control for the phase-shifted series resonant converter, □ *IEEE Trans. Power Electron.*, vol. 23, no. 1, pp. 353-358, Jan. 2008.
- [9] H. Fujita and H. Akagi, —Pulse-density-modulated power control of a 4 kW, 450 kHz voltage-source inverter for induction melting applications, □ *IEEE Trans. Ind. Appl.*, vol. 32, no. 2, pp. 279-286, Mar. /Apr. 1996.

