

October 2011

Flux and Speed estimation of decoupled induction motor

P. Prabhavathi

GMRIT, EEE Dept, prabha.pragada@gmail.com

P. Devendra

GMRIT, EEE Dept, devendra.p.07@gmail.com

Ch. Anand Babu

GMRIT, EEE Dept, anandababu43@gmail.com

Follow this and additional works at: <https://www.interscience.in/ijarme>



Part of the [Aerospace Engineering Commons](#), and the [Mechanical Engineering Commons](#)

Recommended Citation

Prabhavathi, P.; Devendra, P.; and Anand Babu, Ch. (2011) "Flux and Speed estimation of decoupled induction motor," *International Journal of Applied Research in Mechanical Engineering*: Vol. 1 : Iss. 2 , Article 1.

DOI: 10.47893/IJARME.2011.1014

Available at: <https://www.interscience.in/ijarme/vol1/iss2/1>

This Article is brought to you for free and open access by the Interscience Journals at Interscience Research Network. It has been accepted for inclusion in International Journal of Applied Research in Mechanical Engineering by an authorized editor of Interscience Research Network. For more information, please contact sritampatnaik@gmail.com.

Flux and Speed estimation of decoupled induction motor

P.Prabhavathi¹, P.Devendra², Ch.Anand Babu³
 GMRIT, EEE Dept

e-mail:prabha.pragada@gmail.com, devendra.p.07@gmail.com, anandababu43@gmail.com

ABSTRACT: This paper presents the rotor flux and speed estimation of induction motor using a novel technique. The induction motor model in rotor reference frame is considered. Controllers used for sensor less control of the drive. The estimation technique works well and the sensor less speed control scheme can achieve fast transient response as good as that of the induction motor with sensors and at the same time maintain a wide speed control range.

Keywords:

Induction motor, rotor reference frame, sensorless control, flux estimation, speed estimation.

1. INTRODUCTION

Induction motors are used in variable speed drive applications with the development of vector control technology.

Induction motors are increasingly used in variable speed drive applications with the development of vector control technology^{1,2}. There are two forms of vector or field oriented control: direct field orientation, which relies on direct measurement or estimation of the rotor flux, and indirect field orientation, which utilizes an inherent slip relation. Though indirect field orientation essentially uses the command (reference) rotor flux, some recent works using the actual rotor flux are reported to achieve perfect decoupling.

The implementation of direct field orientation via airgap flux measurement has typically been plagued by the complexities and lack of mechanical robustness associated with intrusive sensors located within machine airgap. Furthermore, a correction is required for the rotor leakage flux if rotor flux field orientation is to be achieved. Estimation rather than measurement of the rotor flux is an alternative approach for both direct and indirect field orientation that has received considerable attention³⁻⁸. In many popular implementations of field oriented induction machine drives, rotor flux is estimated from the terminal variables such as stator voltage and current, and rotor speed.

The task of rotor flux estimation may also be expected to arise in other approaches to control and monitoring of induction machines.

In many applications it is neither possible nor desirable to install speed sensors from the standpoints of cost, size, noise immunity and reliability of the induction motor drive. So, the development of shaft sensorless adjustable speed drive has become an important research topic^{9, 10}. There are two major concerns in the sensorless speed control of induction motor drive. One is the control scheme, and other one is the estimation by using speed and flux estimator. Both are highly dependent on the motor parameters.

2. INDUCTION MOTOR MODEL

From the voltage equations of the induction motor in the arbitrary rotating d-q reference frame, the state space model with stator current and rotor flux components as state variables is:

$$\frac{d}{dt} \begin{bmatrix} i_s \\ \Psi_r \end{bmatrix} = \begin{bmatrix} A_{11} & A_{12} \\ A_{21} & A_{22} \end{bmatrix} \begin{bmatrix} i_s \\ \Psi_r \end{bmatrix} + \begin{bmatrix} B_1 \\ 0 \end{bmatrix} V_s \quad \dots\dots(1)$$

$$i_s = y = [i_{ds} \quad i_{qs}]^T, \Psi_r = [\Psi_{dr} \quad \Psi_{qr}]^T; V_s = [V_{ds} \quad V_{qs}]^T$$

$$A_{11} = -a_1 I - \omega_e J \quad A_{12} = a_2 I - a_3 P \omega_r J$$

$$A_{12} = a_5 I; A_{22} = -a_1 I - (\omega_e - P \omega_r) J$$

$$B_1 = c I$$

$$I = \begin{bmatrix} 1 & 0 \\ 0 & 1 \end{bmatrix} \quad \text{and} \quad J = \begin{bmatrix} 0 & -1 \\ 1 & 0 \end{bmatrix}$$

$$c = L_r / (L_s L_r - L_m^2)$$

$$a_1 = c R_s + c R_r L_m^2 / L_r^2 \quad a_2 = c R_r L_m / L_r^2$$

$$a_3 = c L_m / L_r; \quad a_4 = R_r / L_r$$

$$a_5 = R_r L_m / L_r$$

The torque developed by the motor is:

P= number of pole pairs.

$$T_e = K_t (\Psi_{dr} i_{qs} - \Psi_{qr} i_{ds}) \quad \dots\dots\dots(2)$$

where, torque constant,

$$K_t = 3 P L_m / 2 L_r$$

The speed dynamics of the motor is given as:

$$\dot{\omega}_r = (T_e - T_l - \beta \omega_r) / J \quad \dots\dots\dots(3)$$

Equations (1) and (3) describe the fifth order state model of the induction motor. In the motor model described by eqns. (1-3), nonlinearities and

interaction exist. The conditions required for decoupling control of the motor are:

$$\Psi_{dr} = 0 ; \Psi_{qr} = 0 \dots\dots\dots(4)$$

From (1), decoupling is obtained, when

$$\omega_{sl} = \frac{R_r L_m}{L_r} \frac{i_{qs}}{\Psi_{dr}} \dots\dots\dots(5)$$

The nonlinearities in the overall system are eliminated by using input-output linearizing control approach. This approach consists of change of coordinates and use of nonlinear inputs to linearize the system equations. Developed torque, T_e is considered as a statevariable, replacing i_{qs} to describe the motor dynamics. Nonlinear control inputs u_1 and u_2 are used to linearize the motor equations. The input voltages, v_{ds} and v_{qs} to the motor in terms of u_1 and u_2 are:

$$V_{ds} = \frac{1}{c} [-\omega_e i_{qs} + u_1] \dots\dots\dots(6)$$

$$V_{qs} = \frac{1}{c} \left[P\omega_r (i_{ds} + a_3 \Psi_{dr}) + \frac{u_2}{K_t \Psi_{dr}} \right] \dots\dots\dots(7)$$

The induction motor system with these new inputs, is decoupled into two linear subsystems: electrical, and mechanical. The electrical subsystem is described by eqns. (8-9).

$$\frac{d}{dt} i_{ds} = a_1 i_{ds} + a_2 \Psi_{dr} + u_1 \dots(8)$$

$$\frac{d}{dt} \Psi_{dr} = a_5 i_{ds} - a_4 \Psi_{dr} \dots(9)$$

The mechanical subsystem is described by torque and speed dynamic eqns. (10-11).

$$\frac{d}{dt} T_e = (a_1 + a_4) T_e + u_2 \dots(10)$$

$$\frac{d}{dt} \omega_r = (T_e - T_l - \beta \omega_r) / J \dots(11)$$

The state space model of the electrical subsystem is:

$$\frac{d}{dt} x_1 = A_1 x_1 + B_1 u_1 \dots(12)$$

$$y_1 = C_1 x_1 \dots(13)$$

where,

$$x_1 = [i_{ds} \quad \Psi_{dr}]^T$$

$$y_1 = i_{ds}$$

$$B_1 = [1 \quad 0]^T$$

$$C_1 = [1 \quad 0]$$

The state space model of the mechanical subsystem is:

$$\frac{d}{dt} x_2 = A_2 x_2 + B_2 u_2 \dots(14)$$

$$y_2 = C_2 x_2 \dots(15)$$

$$x_2 = [T_e \quad \omega_r]^T$$

$$y_2 = T_e$$

$$B_2 = [1 \quad 0]^T$$

$$C_2 = [1 \quad 0]$$

$$D_2 = \left[0 \quad \frac{-1}{J} \right]^T$$

The rotor flux is estimated by applying the Kalman Filter to discrete time form of eqns. (12-13). The motor speed ω_r is estimated by applying the same algorithm to discrete time form of eqns. (14-15). The Kalman's algorithm for state estimation in linear systems is explained in the next section.

3.P-I CONTROLLERS FOR SPEED AND CURRENT

One P-I controller is used for the flux, or flux component of current as it is adequate for good dynamic response. One P-I controller is used for the speed control, and another for the torque, or torque component of current. The reason for using two P-I controllers (one for speed and the other for torque) in a nested fashion is the significant difference in the time constants of the speed and current, or the electromagnetic torque. The design procedure for these P-I controllers are detailed⁸. The gains are:

$$K_{pd} = 151.24, K_{id} = 43640, K_{pw} = 0.26, K_{iw} = 1.98, K_{pq} = 100, K_{iq} = 29877.$$

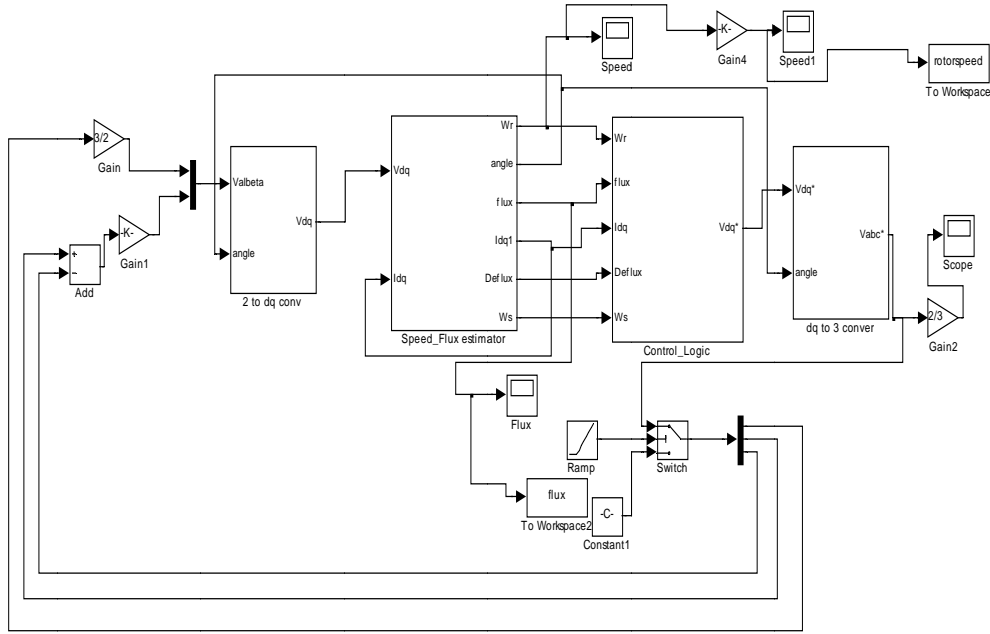

Fig1:MATLAB/Simulink model for Flux and speed estimation of Induction motor

4.FLUX AND SPEED ESTIMATOR

The flux and speed is estimated by using estimator in which a technique has been developed with rotor reference model of induction motor .The current measurements are required for both estimation and control purposes.But voltage measurements are considered only for control purpose. Measured estimation and control purposes. But, voltage measurements are taken only for control purpose. Measured currents are transformed from 3-phase to rotating d-q reference frame components, i_{ds} and i_{qs} .

5. RESULTS AND DISCUSSIONS

6.SIMULATION RESULTS

The out put wave forms of rotor flux and speed are mainly observed as show in fig2&3 and also the results of electromagnetic torque slip speed and voltage are obtained by considering the rotor reference frame model of induction motor.

The simulation study of the system has been carried out with an induction motor whose rating and parameters are given in Table 1.

Table – 1 Rating and Parameters of the Induction Motor Three phase, 50 Hz, 0.75 kW, 220V, 3A, 1440 rpm
Stator and rotor resistances: $R_s = 6.37 \Omega$, $R_r = 4.3 \Omega$
Stator and rotor self inductances: $L_s = L_r = 0.26$ H
Mutual inductance between stator and rotor: $L_m = 0.24$ H
Moment of Inertia of motor and load: $J = 0.0088 \text{ Kg} \cdot \text{m}^2$
Viscous friction coefficient: $\beta = 0.003 \text{ N} \cdot \text{m} \cdot \text{s/rad}$

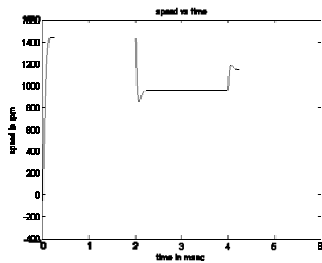

Fig2. Rotor Speed

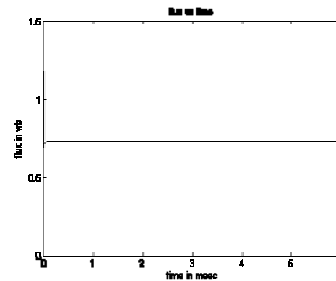

Fig3. Rotor Flux

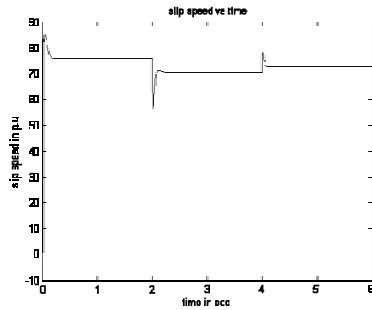

Fig4.Slip Speed

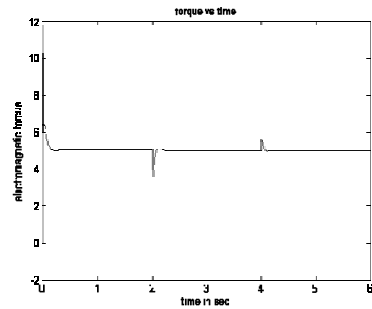

Fig5.Electromagnetic Torque

7. CONCLUSIONS

The estimation of rotor flux and speed of induction motor is presented by the rotor reference frame model equations by using the flux and speed estimator. The dynamic response of sensor less speed control is as fast as that of the machine with physical sensors. Sensor less speed control scheme works for a wide speed control range.

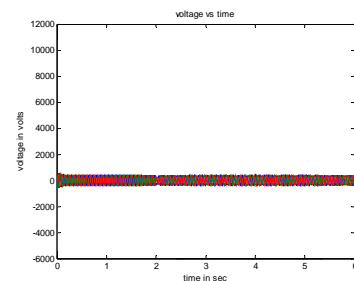

Fig6.Voltage

7. CONCLUSIONS

The estimation of rotor flux and speed of induction motor is presented by the rotor reference frame model equations by using the flux and speed estimator. The dynamic response of sensor less speed control is as fast as that of the machine with physical sensors. Sensor less speed control scheme works for a wide speed control range.

REFERENCES:

- [1] W. Leonhard, *Control of Electrical Drives*, Springer-Verlag, Berlin, 1990.
- [2] D. W. Novotny, and R. D. Lorenz (eds.), "Introduction to Field Orientation and High Performance AC Drives", IAS Annual Meetings: Tutorial book, IEEE, 1986.
- [3] Y. Hori, V. Cotter, and Y. Kaya, "A novel induction machine flux observer and its application to a high performance ac drive system", *Proc. of 10th IFAC World Congress, IFAC, Munich, July 1987*.
- [4] G. C. Verghese, and S. R. Sanders, "Observers for flux estimation in induction machines", *IEEE Trans. on Indust. Elect.*, vol. 35, no. 1, pp. 85-94, 1988.
- [5] P. L. Jansen, and R. D. Lorenz, "A physically insightful approach to the design and accuracy assessment of flux observers for field oriented induction machine drives", *IEEE Trans. on Ind. Appl.*, vol. IA-30, no. 1, pp. 101-110, 1994.
- [6] H. Kubota, and K. Matsuse, "Flux observer of induction motor with parameter adaption for wide speed range motor drives", *Proc. IPEC*, pp. 1213-1218, Tokyo, 1990.
- [7] Y. Hori, and T. Umeno, "Flux observer based field orientation (FOFO) controller for high performance torque control", *Proc. IPEC*, pp. 1219-1226, Tokyo, 1990.
- [8] K. B. Mohanty, *Study of Different Controllers and Implementation for an Inverter Fed Induction Motor Drive*, Ph. D. Thesis, IIT Kharagpur, May 2001.
- [9] K. Ohnishi, N. Matsui, and Y. Hori, "Estimation, identification and sensorless control in motion control system," *Proc. of IEEE*, vol. 82, no. 8, pp. 1253-1265, Aug. 1994.
- [10] K. Rajashekara, A. Kawamura, and K. Matsuse, *Sensorless Control of AC Motor Drives: Speed and Position Sensorless Operation*, IEEE Press, Piscataway, NJ, 1996.
- [11] R. E. Kalman, "A new approach to linear filtering and prediction problems", *Trans. of ASME, Journal of Basic Engg.*, vol. 82-D, pp. 35-45, 1960.
- [12] Peter D. Joseph, *Kalman Filter Tutorials*, website