

January 2013

Design and Analysis of Composite Leaf Spring

Y. N. V. Santhosh Kumar

Nimra College of Engineering & Technology, Ibrahimpatnam, Vijayawada, santhosh.nagarjuna@gmail.com

M. Vimal Teja

Nimra College of Engineering & Technology, Ibrahimpatnam, Vijayawada, M.VimalTeja@gmail.com

Follow this and additional works at: <https://www.interscience.in/ijmie>



Part of the [Manufacturing Commons](#), [Operations Research](#), [Systems Engineering and Industrial Engineering Commons](#), and the [Risk Analysis Commons](#)

Recommended Citation

Kumar, Y. N. V. Santhosh and Teja, M. Vimal (2013) "Design and Analysis of Composite Leaf Spring," *International Journal of Mechanical and Industrial Engineering*: Vol. 2 : Iss. 3 , Article 12.

DOI: 10.47893/IJMIE.2013.1096

Available at: <https://www.interscience.in/ijmie/vol2/iss3/12>

This Article is brought to you for free and open access by the Interscience Journals at Interscience Research Network. It has been accepted for inclusion in International Journal of Mechanical and Industrial Engineering by an authorized editor of Interscience Research Network. For more information, please contact sritampatnaik@gmail.com.

Design and Analysis of Composite Leaf Spring

Y. N. V. Santhosh Kumar & M. Vimal Teja

Dept. of Mechanical Engineering, Nimra College of Engineering & Technology, Ibrahimpatnam, Vijayawada
E-mail: santhosh.nagarjuna@gmail.com

Abstract - In these paper, composite structures for conventional metallic structures has many advantages because of higher specific stiffness and strength of composite materials is discussed. The automobile industry has shown increased interest in the replacement of steel spring with fiberglass composite leaf spring due to high strength to weight ratio. This work deals with the replacement of conventional steel leaf spring with a Mono Composite leaf spring using E-Glass/Epoxy. The design parameters were selected and analyzed with the objective of minimizing weight of the composite leaf spring as compared to the steel leaf spring. The leaf spring was modeled in Pro/E and the analysis was done using ANSYS Metaphysics software.

Keywords - Composite Material, Steel Leaf Spring, Pro-E, FEA, ANSYS.

I. INTRODUCTION

Originally called laminated or carriage spring, a leaf spring is a simple form of spring, commonly used for the suspension in wheeled vehicles. It is also one of the oldest forms of springing, dating back to medieval times. Sometimes referred to as a semi-elliptical spring or cart spring, it takes the form of a slender arcshaped length of spring steel of rectangular cross-section. The center of the arc provides location for the axle, while tie holes called eyes are provided at either end for attaching to the vehicle body. For very heavy vehicles, a leaf spring can be made from several leaves stacked on top of each other in several layers, often with progressively shorter leaves.

Leaf springs can serve locating and to some extent damping as well as springing functions. A leaf spring can either be attached directly to the frame at both ends or attached directly at one end, usually the front, with the other end attached through a shackle, a short swinging arm. The shackle takes up the tendency of the leaf spring to elongate when compressed and thus makes for softer springiness.

The automotive industry is exploring composite materials for structural components construction in order to obtain the reduction of weight without decrease in vehicle quality and reliability. To conserve the natural resources and economize energy, weight reduction has been the main focus of automobile manufacturer in the present scenario. Actually, there is almost a direct proportionality between the weight of the vehicle and

its fuel consumption, particularly in city driving. The advanced composite materials such as Graphite, Carbon, Kevlar and Glass with suitable resins are widely used because of their high specific strength (strength/density) and high specific modulus (modulus/density).

Advanced composite materials seem ideally suited for suspension (leaf spring) applications. Their elastic properties can be tailored to increase the strength and reduce the stresses induced during application.

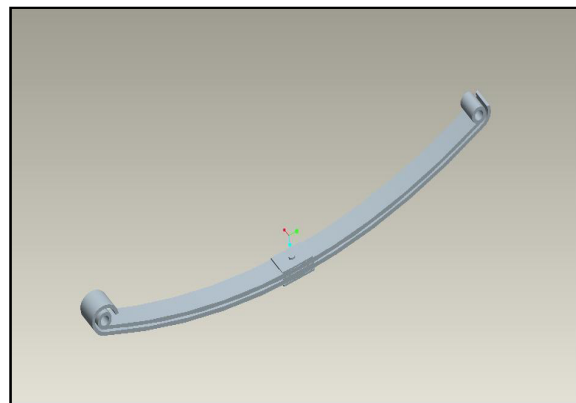

Fig. 1 : Leaf Spring

The objective of the present work is to design the E-Glass/Epoxy composite leaf spring without change in stiffness for automobile Suspension system and analyze it. This is done to achieve the following.

- To the replace conventional steel leaf springs with Eglass/Epoxy composite leaf spring without change in stiffness.
- To achieve substantial weight reduction in the suspension system by replacing steel leaf spring with composite leaf spring.

II. PRINCIPLE OF LEAF SPRING

The suspension leaf spring is one of the potential items for weight reduction in automobile as it accounts for ten to twenty percent of the unsprung weight. The introduction of composites helps in designing a better suspension system with better ride quality if it can be achieved without much increase in cost and decrease in quality and reliability. In the design of springs, strain energy becomes the major factor. The relationship of the specific strain energy can be expressed as

$$U = \sigma^2 / \rho E$$

Where σ is the strength,

ρ is the density and E is the Young’s Modulus of the spring material

It can be easily observed that material having lower modulus and density will have a greater specific strain energy capacity. The introduction of composite materials made it possible to reduce the weight of the leaf spring without reduction of load carrying capacity and stiffness due to the following factors of composite materials as compared to steel.

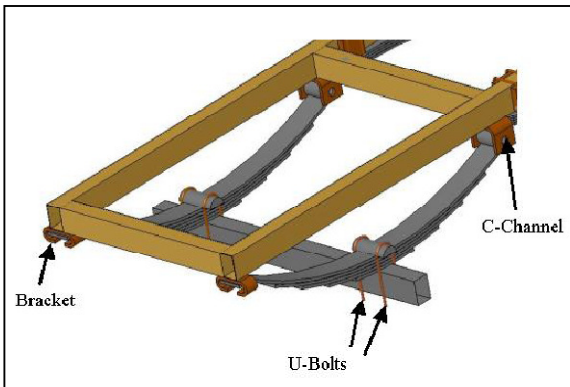

Fig. 2 : Arrangement of leaf spring in a car Model

An upturned spring eye is used to attach the front end of semi-elliptic leaf spring to the chassis frame, and a free end with a bracket constraining vertical motion to attach the back end of semi-elliptic leaf spring to the chassis frame.

A Composite in engineering sense is any materials that have been physically assembled to form one single bulk without physical blending to form a homogeneous

material. The resulting material would still have components identifiable as the constituent of the different materials. One of the advantages of composite is that two or more materials could be combined to take advantage of the good characteristics of each.

III. DESIGN OF LEAF SPRING

Considering several types of vehicles that have leaf springs and different loads on them, various kinds of composite leaf spring have been developed. In the case of multi- leaf composite leaf spring, the interleaf spring friction plays a spoil spot in damage tolerance. It has to be studied carefully.

In the present work, only a leaf spring with constant thickness, constant width design is analyzed.

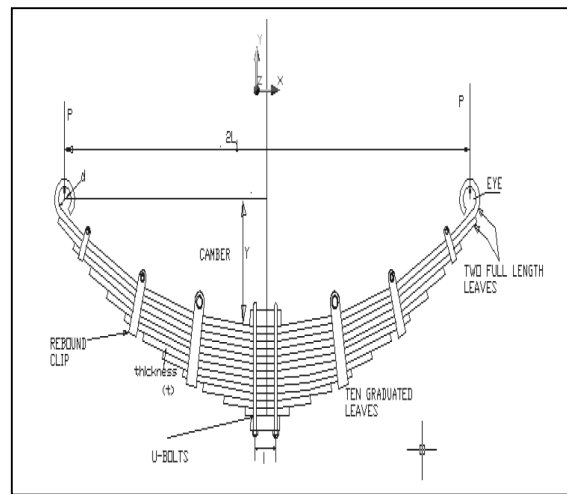

Fig.3 : Main Parts of Leaf Spring

The following cross-sections of leaf spring for manufacturing easiness are considered.

1. Constant thickness, constant width design
2. Constant thickness, varying width design
3. Varying width, varying width design.

Table 1 Design Specifications

Parameter	Specification
Material	Steel(55Si2Mn90)
Tensile Strength	1962N/Sq. mm
Yelid Strength	1470N/Sq.mm
Young's Modulus	2.1e5 N/Sq.mm
Spring Weigth	16.4 Kg
Thickness at the Center	12mm
Thickness at extreme ends	9mm

For steel leaf spring cross section is according to considered design and not altered. Due to manufacturing ease, a composite leaf spring with uniform rectangular cross section is considered and analyzed.

IV. PROBLEM DEFINITION

Objective of present work is to consider an existing automobile leaf spring model TATA SUMO EZRR PARABOLIC REAR and to design and analyze a composite leaf spring with upturned eye without changing stiffness in order to replace the existing steel leaf spring with a composite leaf spring.

A spring eye is essentially the end of a leaf spring bended into a circular shape to allow rotation about the spring eye. The main types of spring eye designs are upturned, military wrapper, down turned, and Berlin eyes Fig: 4. Types Upturned eyes are the most commonly used type of spring eye because of their simple design and high durability. Upturned eyes are highly durable because they resist stress due to vertical forces on a suspension system.

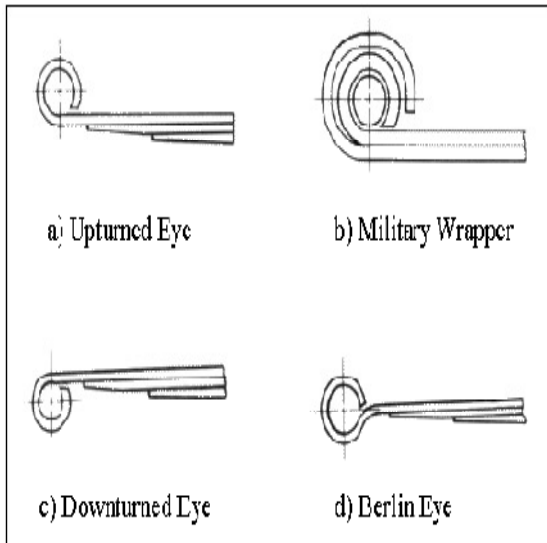

Fig. 4 : Types of Spring Eyes

Unlike other spring eye designs, an upturned eye applies vertical loads on the linear leaf section that was not bent to form the eye. Therefore, upturned eyes have less of a tendency to unwrap as result of vertical forces than the other types of spring eyes.

The Following Assumptions are made for this work.

1. The leaf spring has a uniform, rectangular cross section.
2. All non- linear effects are excluded.

3. The stress-strain relationship for composite material is linear and elastic; hence Hooke’s law is applicable for composite materials.
4. Acoustical fluid interactions are neglected, i.e., the leaf spring is assumed to be in vacuum.
5. The load is distributed uniformly at the middle of the leaf spring.

V. STATIC ANALYSIS OF LEAF SPRING

The leaf spring modeled in Pro/E was imported to ANSYS in IGES format. Since leaf spring was modeled as a solid, solid element named SOLID187 was used to mesh the model. SOLID187 element is a higher order 3-D, 10-node element. SOLID187 has a quadratic displacement behavior and is well suited to modeling irregular meshes (such as those produced from various CAD/CAM systems). The element is defined by 10 nodes having three degrees of freedom at each node: translations in the nodal x, y, and z directions. The element has plasticity, hyper elasticity, creep, stress stiffening, large deflection, and large strain capabilities.

The geometry, node locations, and the coordinate system for this element are shown in the figure 5.

In addition to the nodes, the element input data includes the orthotropic or anisotropic material properties. Orthotropic and anisotropic material directions corresponding to the element coordinate directions.

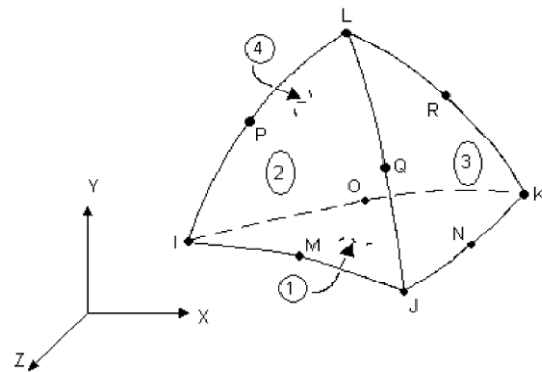

Fig. 5 : Solid 187 3D 10 node tetra hydral structure

VI. RESULTS AND CONCLUSIONS

It was observed that the deflection in the composite leaf spring was almost equal so we can say that composite spring had the same stiffness as that of steel spring.

It was observed that the composite leaf spring weighed only 39.4% of the steel leaf spring for the analyzed stresses. Hence the weight reduction obtained

by using composite leaf spring as compared to steel was 60.48 %.

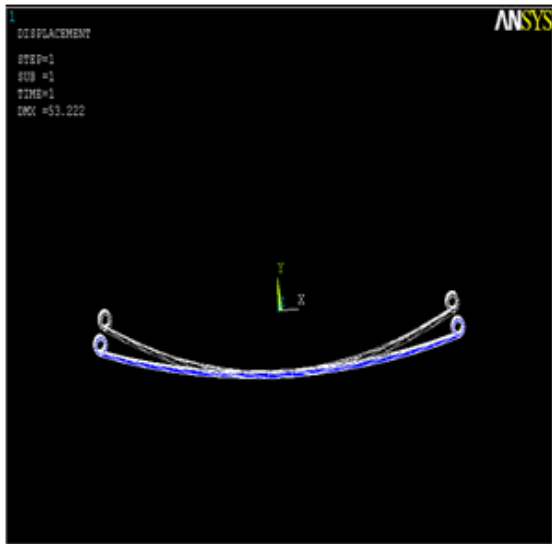

Fig.6 : Deflection of Master Leaf (Steel)

By analyzing the design, it was found that all the stresses in the leaf spring were well within the allowable limits and with good factor of safety. It was found that the longitudinal orientations of fibers in the laminate offered good strength to the leaf spring. Ride quality is generally quantified as the natural frequency of a suspension system.

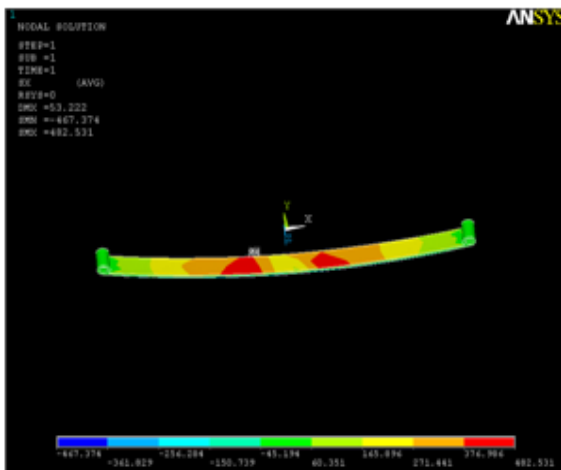

Fig. 7 : x Component of Stress in Master Leaf strings

Suspension system natural frequencies less than 1 Hz will cause motion sickness in a vehicle’s passengers, and suspension system natural frequencies greater than 2.5 Hz will provide a “harsh” ride.

In the present work, the 2mode shape of the composite leaf spring has a natural frequency of 1.7444Hz and 1.7496 Hz which provides for good ride quality.

Table 2 Normal Stresses in Shear

Leaf	oxy(Mpa)		oyz(Mpa)		ozx(Mpa)	
	Max	Min	Max	Min	Max	Min
Master	79.73	-89.3	24.36	-25.66	18.02	-12.69
Second	89.78	-86.05	40.45	-26.07	34.96	-36.32
Composite	18.28	-23.26	5.25	-5.42	3.37	-3.28

Table 3 Deflection in Load String

Material	Maximum Deflection	Max. Average	Total
Steel	Mater	53.22	52.7
	Second	52.18	
Composite Leaf	54.03	54.03	-

ACKNOWLEDGEMENTS

The authors would like to thank the anonymous reviewers for their comments which were very helpful in improving the quality and presentation of this paper.

REFERENCES:

- [1] J. Andreasson, M. Gavert. The VehicleDynamics Library Overview and Applications Modelon., Homepage:http://www.modelon.se/. In Proceedings of Modelica’ 2006, Vienna, Sep. 2006.
- [2] Georg Rill, Norbert Kessing, Olav Lange and Jan Meier: Leaf Spring Modelling for Real Time Applications In the 18th IAVSD-Symposium in Atsugi, Japan 2003, 2003.
- [3] SAE: Spring Design Manual ISBN: 1-56091-680-X, 1996.
- [4] A grimm, C. Winkler and ,R. Sweet Mechanics of Heavy Duty Truck Systems. University of Michigan transportation research institute, UK , 2004.
- [5] Chen, F. C., and Hsu, M. H., 2001, “On the Transmission Efficiency of Spring-Type Operating Mechanism for SF6 Gas Insulated Circuit Breakers,”J. Mech. Eng. Sci., 215(10), pp. 1239–1249.
- [6] Fu-Chen Chen, “Dynamic response of spring-type operating mechanism for 69 KV SF6 gas insulated circuit breaker,” Mechanism and Machine Theory, Volume 38, 2003, Pages 119-134.