

8-5-2006

## The Mass Housing Dilemma: An Industrial Design Process in Architecture

Shaima Ghazi Al Arayedh

Follow this and additional works at: <https://scholarsjunction.msstate.edu/td>

---

### Recommended Citation

Al Arayedh, Shaima Ghazi, "The Mass Housing Dilemma: An Industrial Design Process in Architecture" (2006). *Theses and Dissertations*. 4562.

<https://scholarsjunction.msstate.edu/td/4562>

This Graduate Thesis - Open Access is brought to you for free and open access by the Theses and Dissertations at Scholars Junction. It has been accepted for inclusion in Theses and Dissertations by an authorized administrator of Scholars Junction. For more information, please contact [scholcomm@msstate.libanswers.com](mailto:scholcomm@msstate.libanswers.com).

THE MASS HOUSING DILEMMA  
AN INDUSTRIAL DESIGN PROCESS  
IN ARCHITECTURE

By

Shaima Ghazi Al Arayedh

A Thesis  
Submitted to the Faculty of  
Mississippi State University  
in Partial Fulfillment of the Requirements  
for the Degree of Master of Science  
in Architecture  
in the School of Architecture, Art, and Design

Mississippi State University

August 2006

Copyright by  
Shaima Ghazi Al Arayedh  
2006

THE MASS HOUSING DILEMMA  
AN INDUSTRIAL DESIGN PROCESS  
IN ARCHITECTURE

By

Shaima Ghazi Al Arayedh

Approved:

---

Larry R. Barrow  
Associate Professor of Architecture  
(Director of Thesis)

---

David Lawrence  
Director of Raspet Flight research  
Laboratory  
Aerospace engineering  
(Committee Member)

---

Anijo Punnen Mathew  
Assistant Professor of Architecture  
(Committee member)

---

Shilpi Kumar  
Assistant Professor of Architecture  
(Committee Member)

---

Larry R. Barrow  
Graduate Program Director  
College of Architecture, Art, and Design

---

Jim West  
Dean of College of Architecture, Art, and  
Design

Name: Shaima Ghazi Al Arayedh

Date of Degree: August 5, 2006

Institution: Mississippi State University

Major Field: Architecture

Major Professor: Dr. Larry R. Barrow

Title of Study: THE MASS HOUSING DILEMMA-AN INDUSTRIAL DESIGN PROCESS IN  
ARCHITECTURE

Pages in Study: 238

Candidate for Degree of Master of Science in Architecture

World population growth and global warming are accentuating the long recognized problem of housing for the masses; millions are homeless, live in inadequate shelter, or as in the US Manufactured Housing market that is the focus of this thesis, live in nondurable poor quality “manufactured” houses that are detrimental to health, at best, or during extreme weather events, suffer catastrophic damages often resulting in death to occupants.

In this thesis, we have reviewed the role of the architect in the US Manufactured Housing industry; additionally, we identified the major problems that plaque the US Manufactured Housing Industry. Further, we have reviewed how architects and Industrial Designers use technology in their respective fields. Our findings and analysis suggest that an Industrial Design approach, applied in architecture for mass housing, offers a means of improving the architect’s role in manufactured housing for the masses.

DEDICATION

To

Mom and Dad

## ACKNOWLEDGMENTS

Between my overestimation of my capabilities and my naive underestimation of the effort behind researching and writing a thesis, little did I anticipate that I would owe so much to so many in the course of my research and writing.

My thanks goes to all those behind the administration and organization of the Fulbright International Scholarship Program for adding a rich and enlightening cultural perspective in an effort to bridge east and west to my education in the past two years. In the AMIDEAST office in Washington D.C., I would like to acknowledge Sarah Belanger, Julie Fitzgerald, Josephine Griffin and Aseel El Borno. In the American Embassy in Bahrain my thanks goes to Dana Jawahery, George Farag, and Samar Hassan.

I would also like to express my thanks and appreciation to Dr. Phil Bonfanti, Dr. Stephen Cottrell, Ms. Carol Walker, Ms. Sabrina Leng, and Ms. Shaz Akram from the International Student Office in Mississippi State University for their continuous support and help with the inevitable formalities during my stay in the States.

My thanks goes to my Advisors, professors, and teachers; Dr. Despina Al Samaheji, Dr. Souheil El Masri, Ms. Lejla Karajica, Dr. Saeed Abdul Raheem, Dr. Mohsin Al Alawi, Dr. Adel Abdulla, Dr. Mustafa Ben-Hamuiche and Dr. Sina Berkosz in the Department of Civil and Architectural Engineering in the University of Bahrain for their advice and encouragement as I first set to seek further knowledge and throughout this venture, compelled by the passion for architecture that they have instilled in me and for which I will forever be indebted.

In the College of Architecture, Art, & Design in MSU I would like to thank Ms. Susan Hall and Ms. Judy Hammett from the Architecture Library for their invaluable

help in acquiring the resources and references during my research. I am also indebted to Professor Michael Berk, for his help and his suggested references and comments during my research into indigenous and vernacular housing.

In the Graduate Program I would like to thank my colleagues of the class of 2005, Alison Wade, Renata Al Meida, Priya Sathiyarayanan, and Nathaniel Pierce; from the class of 2006 I extend my thanks to Lalatendu Satpathy, Julie Bartholomew, Kirk Douglas, David Wright, Sneha Kochak, Joseph Williams, Vikash Singh, Bo Zhao, James Johnson, Seishi Unuma, Justin Taylor, and Howard Johnson, each of whom had a contribution, though perhaps unknowingly, in the progress of this research project through the stimulating conversations and during the interesting DDII sessions. My special thanks goes to Sarah Pittman, the Graduate Program Coordinator, for her care and concern and for her efforts to keep spirits high as deadlines loomed and stress intensified.

I am grateful for the time and advice spared by my committee members. I would like to thank Mr. David Lawrence, for his broad perspective and sharp comments which have proved invaluable to this research. I am indebted to Shilpi Kumar and Anijo Mathew, for their continuous support during the process of my research and writing; for their insightful remarks and comments as my professors in the program and their help and concern during my time in Mississippi.

I am forever indebted to my professor, thesis advisor and committee member, Dr. Larry Barrow for his courage in taking up the roles of the advisor, the mentor, the friend, and at times the parent of a very difficult student. For his unselfishness in sharing his ideas, and his guidance as he presented a rich and stimulating field of knowledge, for the time he sacrificed and the pains he took in conversing with a naïve student only to raise the level of conversation and to widen perspectives, for his unique teaching method and his vivid and engaging analogies. I am afraid words fail to express



my thanks and gratitude.

To my dear friends and colleagues in Bahrain, Fatima Al Halay, Amina Al Madhoob, and Hessa Al Banna who, despite my long months of absence and the countless unanswered emails and messages, have not ceased to check in on me every now and then and have always been ready to lend an attentive ear and dispense supportive comments. I am truly lucky and privileged to have such rare friendships.

Last but not least, I wish to thank my dear parents, Dana Al Anjawi and Ghazi Al Arayedh for their unwavering support, for their fighting the urge to keep me close and safe as they encouraged me to take roads not taken. For their foresight, their wisdom their trust for which I know I would never be able to repay.

To those I have mentioned above and to the many others that I have failed to list yet who have inspired me over the years, I dedicate the following lines:

*We shall not cease from exploration  
And the end of all our exploring  
Will be to arrive where we started  
And know the place for the first time.*

From "Little Gidding" by T.S. Eliot 1969 P.145

## TABLE OF CONTENTS

	Page
DEDICATION.....	ii
ACKNOWLEDGMENTS.....	iii
LIST OF TABLES.....	xi
LIST OF FIGURES.....	xii
GLOSSARY OF TERMS.....	xvii
 CHAPTER	
I. INTRODUCTION.....	1
II. METHODOLOGY.....	4
III. ARCHITECTURE AND MASS HOUSING.....	7
Introduction.....	7
Pioneers of the Modern Movement.....	9
Walter Gropius and the Copper and Packaged Houses.....	9
Le Corbusier and the F.Q.M in Pessac.....	13
Buckminster Fuller’s Dymaxion Dwelling Machine.....	17
Jean Prouve’s Tropical House.....	23
The 60’s.....	27
The Archigram Group.....	27
Moshe Safdie and Habitat ‘67.....	28
Paul Rudolph’s 1968 Ventures.....	31
Kisho Kurokawa and the Metabolism Movement.....	35
The Turn of the Century.....	38
Conclusion.....	41
Key Points.....	43
IV. FACTORY BUILT HOUSING.....	45
Introduction.....	45
Historical Background.....	45
The Automobile and the Recreational Vehicle.....	46
From Recreational Vehicles to Temporary Housing.....	46
From Temporary Housing to Permanent Mobile Homes.....	48

CHAPTER	Page
Codes and Legislations .....	49
Manufactured Housing Residents Today .....	50
The Manufactured Housing Industry .....	55
The Product .....	60
Problems .....	68
Flammability .....	69
Vulnerability to Extreme Weather Conditions .....	71
Indoor Air Quality .....	79
Financing and Insurance .....	82
Durability .....	85
Transportation .....	87
Aesthetics, Perception, and Zoning and Regulations .....	91
Conclusion .....	94
Key Points .....	96
V. TECHNOLOGY AND ARCHITECTURE .....	100
Introduction .....	100
Early Applications .....	100
Architecture of Frank O. Gehry & Partners .....	103
Architecture of Foster & Partners .....	109
Bernard Franken Architecture .....	113
Greg Lynn FORM .....	113
SHoP Architects .....	119
Architecture, Technology, and Houses .....	123
Conclusion .....	128
Key Points .....	132
VI. TECHNOLOGY AND INDUSTRY .....	136
Introduction .....	136
The Industrial Design Process .....	137
The Role of Modularity in Industrial Design .....	142
Achieving Variability through Mass Customization .....	143
Applications in the Automotive Industry .....	146
Applications in the Aerospace Industry .....	150
Conclusion .....	153
Key Points .....	154
VII. FINDINGS AND ANALYSIS .....	156
Proof of Hypothesis .....	167
Prefabricated Housing Categorization .....	168
The Industrial Design Approach .....	170
Establishing an Integrative Collaboration .....	172
Market Research and Consumer Studies .....	173
Form and Performance Studies .....	175
Simplification and Standardization .....	176
Design for Modularity .....	179

CHAPTER	Page
Application of Mass Customization Strategies .....	182
Application of Flexible Manufacturing Strategies .....	183
Conclusion.....	185
VIII. CONCLUSION .....	186
BIBLIOGRAPHY.....	189
APPENDIX	Page
A MH MANUFACTURERS' SURVEY QUESTIONS.....	196
B CAVALIER HOMES INC. CASE STUDY .....	198
C TRAILERS, VITAL AFTER HURRICANES, NOW POSE OWN RISK AT GULF .....	233

## LIST OF TABLES

TABLE	Page
4.1 The Saffir-Simpson Hurricane Scale .....	73
4.2 The Fujita Tornado Intensity Scale .....	74
4.3 Financing options for manufactured homes and set requirements for each option. ....	83
4.4 Average costs associated with transportation of manufactured home units.....	89
7.1 Summary of mass housing attempts in the past century as presented in Chapter 3 .....	157
7.2 The Industrial Design approach to design and manufacturing .....	166
7.3 Evaluation of the Industrial Design approach against approaches followed in Architecture, mass housing, and factory assembled housing .....	171
B.1 Benefits of the SAP Project in Cavalier Homes.....	227
B.2 Summary of Cavalier Homes Inc. Case Study .....	232

## LIST OF FIGURES

FIGURE	Page
2.1 Research Methodology .....	6
3.1 Indigenous housing solution developed in the absence of the architect .....	8
3.2 One of Walter Gropius Copper House prototypes.....	12
3.3 Panels and connection used for the Packaged House proposal .....	12
3.4 Le Corbusier’s Domino House .....	14
3.5 Standard modules used in Pessac.....	15
3.6 Pessac modules intermingle with open garden spaces .....	16
3.7 Rendered image of the housing unit in Pessac .....	17
3.8 Color treatment applied to units by painting the façade .....	17
3.9 Housing units with residents’ decorations applied.....	17
3.10 Model of Fuller’s 4D Dymaxion House .....	18
3.11 Plan, section and elevation of the 4D Dymaxion House .....	19
3.12 The Dymaxion Deployment unit .....	20
3.13 Mast supporting DDU structure.....	20
3.14 Plan of the Dymaxion Dwelling Machine.....	22
3.15 Wichita House.....	22
3.16 Plan of the demountable steel vacation house .....	24
3.17 1/10PthP scale prototype of the demountable metal house .....	24
3.18 Exterior view of the Tropical House .....	26
3.19 Interior view of the Tropical House .....	26
3.20 Plug-In City.....	28
3.21 Walking City .....	28
3.22 Capsule .....	28
3.23 The Living Pod .....	28

FIGURE	Page
3.24 Habitat '67 .....	29
3.25 Plan of a rectangular module .....	29
3.26 Module configuration .....	30
3.27 Cross section of the triangular frame supporting the rectangular modules	30
3.28 Paul Rudolph's Graphic Arts Center proposal, New York, New York .....	33
3.29 Oriental Masonic Gardens housing project in New Haven, CT 1968. ....	34
3.30 Prefabricated apartments .....	36
3.31 Takara Beautillion .....	36
3.32 Capsule interior layout.....	37
3.33 Nagakin Tower .....	37
3.34 Take Home Prefab by Jennifer Siegal's Office of Mobile Design .....	39
3.35 Quik Home by Adam Kalkin .....	39
3.36 Kithaus by Tom Sandonato and Martin Wehmann .....	39
3.37 Ban's emergency housing in Kobe, Japan 1995.....	41
4.1 Age of MH householders as a percentage of total MH householders .....	52
4.2 Manufactured homes household composition as percentage of total MH households .....	52
4.3 Educational attainment of MH householders as percentage of total MH householders. ....	53
4.4 Income of MH households as percentage of total MH households .....	54
4.5 Main reason for MH householders' choice of MH as a residence. ....	55
4.6 MH, modular, panelized, and precut homes shipments (1959-2004) .....	56
4.7 Comparison between MH shipments and conventional housing completions (1959- 2004) .....	57
4.8 Comparison between MH placements and conventional housing sales (1959-2004). ....	57
4.9 Comparison between MH housing shipments and RV shipments (1959- 2004).....	58

FIGURE	Page
4.10 Percentage of MH shipments produced by top 10 manufacturers in the industry as a percentage of total MH shipments in 2003.....	59
4.11 Losses in revenue endured by top 10 MH manufacturers in 2003 as percentage of 2002 revenues.....	60
4.12 Comparison of single section and multi section manufactured home shipments (1990-2004).....	61
4.13 Comparison of prices per square footage for single section, Double section, average MH, and conventional housing (1990-2004) .....	62
4.14 Floor assembly phase of MH production.....	64
4.15 Wall installation phase of MH production.....	64
4.16 Roof construction and finishing and testing phases of MH production ...	65
4.17 Roof sheathing material used in conventional and MH housing as percentage of total material used in construction.....	66
4.18 Floor sheathing material used in conventional and MH housing as percentage of total material used in construction.....	67
4.19 Wall sheathing material used in conventional and MH housing as percentage of total material used in construction.....	68
4.20 Deaths per thousand fires in 1 & 2 family conventional housing and manufactured housing.....	69
4.21 Causes and effects of manufactured home units' excessive flammability .	71
4.22 Average 10 year (1994-2004) floods, hurricanes, and tornado fatalities...	72
4.23 MH by percentage of foundation type based on 2001 data.....	75
4.24 MH by method of securing to the foundation based on 2001 data .....	75
4.25 Percentage of manufactured and conventional housing units with walls and roofs as a source of water leakage .....	77
4.26 MH concentration locations relative to floodplain land areas, hurricane direct hits and, high risk tornado zones in the United States .....	78
4.27 Causes and effects of the manufactured home units' vulnerability to extreme weather conditions .....	79
4.28 Median square footage of new conventional single family housing and MH housing built and manufactured (1990 and 2000) .....	80



FIGURE	Page
4.29 Causes and effects of manufactured home units' low indoor air quality...	81
4.30 MH percentages by type of title .....	82
4.31 Causes and effects of manufactured home units' financing and insuring difficulties.....	85
4.32 MH units suffering from specific deficiencies as percentage of total MH units surveyed .....	86
4.33 Cost of fixing deficiencies in MH units.....	87
4.34 Causes and effects of manufactured home units' lack of durability .....	87
4.35 MH units suffering from deficiencies due to improper installation as percentage of total MH units surveyed .....	90
4.36 Causes and effects of manufactured home units' transportation difficulties	90
4.37 Noji Gardens' manufactured homes in comparison to the traditional manufactured housing units.....	91
4.38 Percentage of MH and conventional housing units by placement location	93
4.39 Causes and effects of manufactured home units' low aesthetical appeal, negative perception and prejudiced zoning laws .....	94
5.1 Variation in roof tile shapes .....	101
5.2 Variation in glass pane shapes.....	101
5.3 Structural support of the Kansai Airport, Japan .....	103
5.4 Digital analysis and curvature studies .....	103
5.5 Assembly of the Olympic fish project based on information obtained directly from the CATIA digital model.....	105
5.6 Exterior metal cladding of Disney Concert Hall .....	107
5.7 Exterior façade of the EMP project .....	108
5.8 Façade of the Zollhof Towers in Germany.....	108
5.9 Self shading form of the City Hall.....	111
5.10 Digital sun study for City Hall.....	111
5.11 Aerodynamic form of the Swiss Re HQ .....	111

FIGURE	Page
5.12 Complexly curved roof form of the Gateshead Concert Hall .....	111
5.13 The Hydrogen Pavilion .....	119
5.14 Fashion Institute of Technology .....	121
5.15 Façade study of the Fashion Institute of Technology .....	121
5.16 Wave analysis study.....	122
5.17 Physical model of the Carousel at Greenport .....	122
5.18 Wall components of the Camera Obscura .....	123
5.19 Roof components of the Camera Obscura .....	123
5.20 Physical model of the Lewis Residence .....	124
5.21 Different forms and shapes for different components of the Lewis Residence .....	125
5.22 Form variations of the Embryological House .....	126
5.23 Physical model donated by CNC Dynamix .....	126
5.24 Fabrication and assembly of the Turbulence House .....	128
5.25 Different architectural design approaches based on different priorities and philosophies .....	129
6.1 Swatch watches .....	144
6.2 Nokia cell phones.....	144
6.3 Personal Computers.....	144
6.4 Cut to fit jeans.....	145
6.5 Wire.....	145
6.6 Paint colors.....	145
6.7 Car frame .....	146
6.8 Sectional modularity in Lego blocks .....	146
6.9 Conceptual hand sketches .....	148
6.10 Full scale clay study model .....	148

FIGURE	Page
6.11 The Ford 500 Sedan, Ford Freestyle and Mercury Montego sharing one platform.....	150
6.12 Automated assembly of Boeing 777 modules.....	152
6.13 Customization of the aircraft through application of exterior color schemes .....	152
7.1 Summary of causes and effects of manufactured housing problems as presented in chapter 4 .....	161
7.2 Amount of work carried out in the factory, based on every category of housing types .....	170
7.3 The indigenous versus the Modern .....	173
7.4 Residents reactions to Le Corbusier’s housing proposal in Pessac.....	174
7.5 Impact of technology on architectural form .....	177
7.6 The industry’s approach to utilizing technological applications versus architects’ approaches to integrating technology in practice.....	178
7.7 Today’s technological applications enabling architects to get closer to the craft.....	179
7.8 Transportation of the entire housing unit versus transportation of modular Parts and components .....	181
7.9 Transportation complications based on every category of housing types..	181
7.10 Flexibility for customization based on every category of housing types ....	182
7.11 Housing production versus flexible manufacturing in Industrial Design..	184
B.1 The 14 Facilities Cavalier ran in 2001 .....	203
B.2 Top 10 MH builders comparison, 2000 .....	204
B.3 The assembly line station breakdown in the Buccaneer Homes.....	205

FIGURE		Page
B.4	Implementation Strategy, Cavalier vs. Traditional MH 0=Low 10=High ...	212
B.5	Information Flow Chart of Cavalier Homes (Old) .....	215
B.6	Information Flow Chart of Cavalier Homes (mySAP) .....	216
B.7	Material and Product Flow Chart of Cavalier Homes (Old) .....	217
B.8	Material and Product Flow Chart of Cavalier Homes (mySAP) .....	218
B.9	Number of Home models in Cavalier .....	223
B.10	Cavalier's market share .....	223
B.11	Cavalier's home shipment and industry shipment .....	224
B.12	Cavalier's raw material inventory .....	224
B.13	Cavalier's dealer inventory .....	225
B.14	Production hours per home in Cavalier .....	225
B.15	Number of service vehicles deployed .....	226
B.16	Cavalier's administration workforce .....	226
B.17	Average service cost per home .....	227

## GLOSSARY OF TERMS

Based on definitions from Merriam Webster Collegiate Dictionary.

*Affordability: afford:*

To be able to bear the cost of

*Architecture:*

The art or science of building, specifically; the art or practice of designing and building structures and especially habitable ones.

*Art:*

The Conscious use of skill and creative imagination especially in the production of aesthetic objects, also works so produced

*Better:*

Improved in performance and aesthetic

*Commodity:*

One that is subject to ready exchange or exploitation within a market.

*Customize:*

To build, fit, or alter according to individual specifications.

*Elite:*

A group of persons who by virtue of position or education, exercise much power or influence.

*Homelessness:*

Having no home or permanent place of residence.

*Housing: House:*

To provide with living quarters or shelter

*Interchangeable:*

Capable of being Interchanged, especially permitting mutual substitution.

*Interchangeable:*

To put each of two things in the place of the other.

*Mass:*

Of or relating to the mass of the people. Average, Commonplace.

*Mass production:*

To produce in quantity usually by machine.

*Modularity:*

Constructed with standard units or dimensions for flexibility and variety.

*Module:*

Any in a series of standardized units for use together as a unit of furniture or architecture.

*Quality:*

Degree of excellence.

*Repeat:*

To make appear again.

*Repetition:*

The act or an instance or repeating or being repeated.

*Technology:*

The practical application of knowledge in a particular area.  
For the purpose of the context: Hardware, Software and Humanware

*Variation:*

The act or process or varying; the state or fact of being varied.

*Vary:*

To make a partial change in; make differences in some attribute or characteristic.

## CHAPTER I

### INTRODUCTION

In his renowned introduction, the 14<sup>th</sup> century Arab historian and sociologist, Ibn Khuldun, defined architecture as:

*“The first and oldest craft of sedentary civilization. It is the knowledge of how to go about using houses and mansions for cover and shelter. This is because man has the natural disposition to reflect upon the outcome of things. Thus, it is unavoidable that he must reflect upon how to avert the harm arising from heat and cold by using houses which have walls and roofs to intervene between him and those things on all sides. This natural disposition to think, which is the real meaning of humanity, exists among (men) in different degrees.”<sup>1</sup>*

Hence, architecture and architects were designated the providers of one of humanity’s most basic needs, the need for housing, even before they took the role of professionals in society and “protectors of the general public”<sup>2</sup>.

With the rise of industrialization, the frenzy for industrial mass production spread across different sectors of the industry, slowly penetrating into architecture. Ironically, while other industries were very successful in utilizing the factory environment and emerging technological applications to satisfy people’s needs, ranging from the simplest and most mundane, such as clothing, to their need for means of transportations, and including other objects of luxury and extravagance, both the Modernist architects’ and the homebuilding industry’s efforts to match that success with housing commodities came short of achieving their aim in proposing a sound and permanent mass housing solution.

---

<sup>1</sup> Ibn Kaldun, N.J. Dawood, Bruce Lawrence, Franz Rosenthal, “Al Muqadimmah”, Princeton university press 1969.

<sup>2</sup> Barrow, Larry R. , Cybernetic Architecture; Process and Form The impact of information Technology, Harvard Design School, 2000, P. 91

Meanwhile, the bleak reality of the public's housing conditions emerges as one of the most vital problems confronting the global community in the 21<sup>st</sup> century; a problem that knows no political, racial, religious, or geographical boundaries. The conventional means used in housing construction proves to be too costly and time consuming to catch up with the growing housing demands resulting from the dramatic increase in population. Consequently, millions seek more affordable housing alternatives which offer no guarantees with respect to quality to satisfy their pressing housing needs, while millions of others, who can not afford any of the housing options available, are becoming homeless. In 2005 The United Nations Centre for Human Settlements (UNCHS) estimated that 1.1 billion persons are living in inadequate housing conditions in urban areas. In addition to that the UN-Habitat estimates that nearly 200 million living in poorly designed and low quality housing are displaced annually due to natural disasters.

As the housing problem intensifies, the following question is inevitably posed:

*What is the status of manufactured housing (MH) and can technology enhance the production of commodity housing?*

At the outset of this research we hypothesized that:

*US Manufactured Housing is deficient due to the inability of industry to leverage technological solutions as found in other Industrial Design/Manufacturing processes.*

Research was initiated by general reading in the field of factory built housing and specifically manufactured homes. With the realization that manufactured homes and the problems associated with them are only one aspect of a multi faceted problem that includes housing in general regardless of type, the scope of the research was widened to include these previously overlooked housing typologies. Research also included looking into some of the most renowned attempts of Modern's movement to tackle this issue. In addition to that, current applications of technology both in



architecture and in industry were studied to form the basis of a comparison between its applications in each of the fields.

Chapter 3, Architecture and Mass Housing, displays a concise timeline focusing on some of the most distinguished architectural attempts in the field of mass housing in the past century. Chapter 4, Factory Built Housing, focuses on the development and historical origin, different factory built housing typologies, the characteristics of its residents as well as production processes of factory built homes. The chapter concludes by rating the performance of factory built housing through a comparison to conventional site built homes. Chapter 5, Technology and Architecture, turns to the application of digital technologies in the design and construction processes in architecture. Similarly, chapter 6, Technology and Industry, presents the current applications of technology in industrial design and production. A detailed analysis of the previously presented data is conducted in chapter 7, followed by analysis and display of the research findings. The conclusion in chapter 8 provides an answer to our research question as per the research findings and extends to present the thesis statement that indicates that mass housing production is not enhanced by solely engaging technological applications but by following an appropriate approach to the utilization of these technologies.

## CHAPTER II

### METHODOLOGY

This thesis was based on exploratory research initiated by general reading in the field of manufactured homes. The research covered the origin of manufactured homes, characteristics of the Manufactured housing industry, the typical resident's characteristics, product characteristics and problems associated with the structures. Information was gathered from books, theses, dissertations, national statistical data obtained from US Census Bureau, the Manufactured Housing Institute, and several reports and documents issued by US departments of State and research centers as well as a survey and a case study conducted by the Design Research and Informatics Laboratory at the College of Architecture, Art, and Design in Mississippi state university (see appendices A&B). With the realization of the complexities of the categorization of factory built housing and the associated multi faceted problems due partly to the elimination of technological application in the design and production of factory built homes, the scope of the research was broadened to include previously overlooked factory built housing typologies and further to explore the impact of technological application in architecture and mass housing.

Thus research expanded to survey the mass housing proposals of the architects of the Modern movement during the past century or so focusing mainly on eight mass housing proposals forwarded by renowned architects in the field, namely , Walter Gropius, Le Corbusier, Buckminster Fuller, Jean Prouve, the Archigram Movement, Moshe Safdie, Paul Rudolph and Kisho Kurokawa. Information was obtained through general reading in the history of the architecture of the modern movement with a focus

on the theory behind and characteristics of the housing proposals, the prevailing conditions and circumstances, and the difficulties and challenges confronted.

Information collected from readings in current publications and magazines in addition to architecture firms' websites formed the basis of exploring current technological applications in the field of architecture. Research concentrated on examining the different emerging approaches to the utilization of current technological innovations focusing on five pioneering practices in implementing digital technologies in architectural practice. These practices are, Frank O. Gehry and Partners, Foster and Partners, Bernard Franken, Greg Lynn Form, and SHoP Architects. The study focused on the digital applications in the early conceptual and form generating phases as well as in the later construction and fabrication phases of architectural design and construction. Moreover, further investigation in the role of technological application in the design and construction of housing units in particular was conducted.

Similarly, investigation was carried out to explore current applications of technology in industry. Data was obtained both from readings as well as various companies' websites concentrating mainly on the role of digital technologies in enhancing mass production and manufacturing processes in industrial design. Furthermore, investigation was carried out to study the industry's approaches to the use of technology as a means of achieving a balance between high performance, aesthetical appeal and flexibility for customization.

Analysis of the collected information was carried out through comparisons between the different design and production strategies and varying approaches to utilizing technology in each of the fields previously explored. Such comparisons included architectural housing attempts in the past century. The manufactured housing Industry's approach, Architecture's current approaches and the approach

followed in industrial design. These comparisons form the basis from which stems the main point presented in the conclusion of this thesis (Fig 2.1).

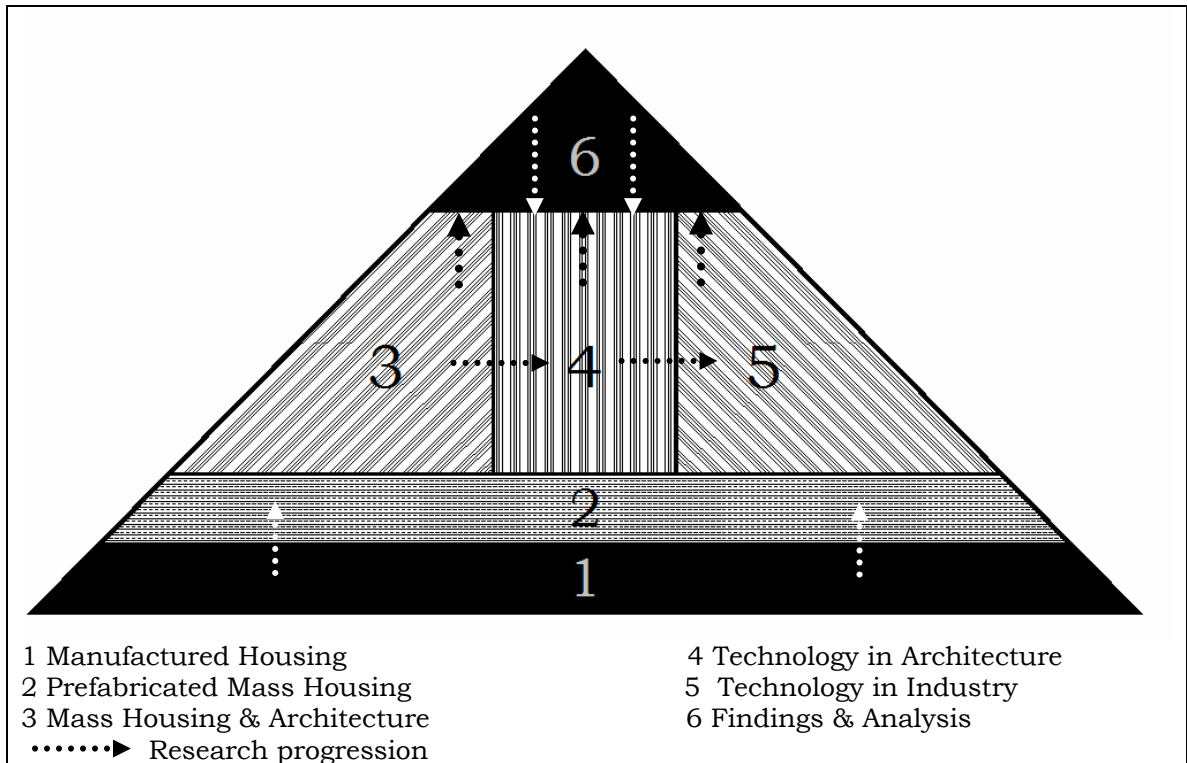

Figure 2.1 Research Methodology

CHAPTER III  
ARCHITECTURE AND MASS HOUSING

**Introduction**

For centuries, architecture and architects' attention has been devoted to catering the needs of the elite. The Stonehenge, The Egyptian pyramids, the Parthenon, the Roman coliseum, Notre Dame cathedral and the Louver, are among thousands of temples, churches, castles and palaces that are standing testimonies of architecture serving the religious, political, the rich and influential of every era and time. Up until the evolution of architecture as a profession in England<sup>1</sup> and with the rise of the industrial revolution in the 18<sup>th</sup> century, people's housing needs were never a primary concern for architects and were thus served by the masses themselves. In the absence of the architect, it was the indigenous that satisfied their own housing needs drawing housing solutions from the surrounding natural environment, and the social and cultural setting. Often it was the residents themselves who were involved in the design and construction process which provided them with an opportunity to closely personalize their residence as they wished through this process. Gradually, and through centuries in which the house was constructed by the locals, a certain image and tradition pertaining to the aesthetical and performance attributes of the housing unit was established depending on the region, and prevailing environment (Fig 3.1).

---

<sup>1</sup> Barrow, Larry R. , *Cybernetic Architecture; Process and Form The impact of information Technology*, Harvard Design School, 2000, P. 91



Figure 3.1 Indigenous housing solution developed in the absence of the architect

However with the changes that occurred and new technologies that appeared, emerged a new factor that played a vital role in shifting this paradigm. Industrialization of the building process exemplified by Joseph Paxton's Crystal Palace in 1851, which was described by a historian at the time as "the first miracle of prefabrication"<sup>2</sup>, was the trigger behind architects' efforts of utilizing such technology in building in general. About 50 years later, the building industry and housing in particular were significantly impacted by the mass production of the automobile and Henry Ford's Statement that revealed his analysis of mass production:

*"The term mass production is used to describe the modern method by which great quantities of a single standard commodity are manufactured. Mass production is not merely quantity production... nor is it merely machine production. Mass production is the focusing upon a manufacturing project of the principles of power, accuracy, economy, system, continuity and speed. The interpretation of these principals, through studies of operation and machine development and their coordination, is the conspicuous task of management. And the normal result is a productive organization that delivers in quantities a useful commodity of standard material, workmanship and design at a minimum cost..."<sup>3</sup>.*

As the Modernist architect arrived at the housing scene early in the twentieth century, his opinions of the existing housing solutions varied. Adolf Loos for example described the houses built by the indigenous as structures that "do not seem manmade but more like the product of God's worship", referring to these efforts as successful in a

---

<sup>2</sup> Sullivan, Barry J., "Industrialization in The Building Industry", Uniworld Industries, 1978, p.16

<sup>3</sup> Herbert, Gilbert, "The Dream of the Factory-Made House", The MIT Press, 1984, P.3

manner similar to “every animal which allows itself to be led by its instincts, succeeds”<sup>4</sup>. Frank Lloyd Wright voiced a more critical opinion stating that “Folk Building growing in response to actual needs, fitted into environment by people who knew no better than to fit them with native feeling” yet admitted that for architects they are “better worth study than all the highly self conscious academic attempts at the beautiful throughout Europe”<sup>5</sup>. Regardless of these opinions, the modernist architect when proposing his mass housing solution rejected including all the decorative elements that are a major aspect of personalized expression in indigenous housing. In that regard Loos expressed that “the path of culture is the path away from ornamentation towards the elimination of ornament.”<sup>6</sup>

It is within this setting that the feverish search for an approach to utilize the principals of mass-production in architecture in the 20<sup>th</sup> century was initiated. The basic human need for shelter, lent itself to being the perfect commodity through which such principals could be put to the test. While it is not the scope of this chapter to outline all the architectural attempts towards this aim, it summarizes the efforts of those who came closest to bring it to reality.

### **Pioneers of the Modern Movement**

Walter Gropius and the Copper and Packaged Houses:

Few architects if any were as devoted to the issue of mass housing and industrialization in building as Walter Gropius was. His Contributions concerning housing started with the design and conventional on-site concrete construction of several houses. Yet, his 1924 statement displays a change in direction:

---

<sup>4</sup> Oliver, Paul, “Dwellings”, Phaidon Press Limited, 2003, P.9

<sup>5</sup> Ibid, P.9

<sup>6</sup> Ibid, P.132

*“For the national Economy it is important that home production costs should be lowered. We have tried to lower the costs of traditional building, but these efforts have shown very small results. The problem should be attacked at its roots. The real solution; houses should not be built at the site, but in specialized factories by serial manufacturing of mountable elements”<sup>7</sup>*

Gropius arrived at this conclusion through several memos and papers that clearly presented his views on the issues of utilizing the industry’s capabilities in housing, and practical work that attempted to ground these views into reality. The period spent with the Bauhaus, building for the industry, presented insight concerning standardization and modularity in industrial production that greatly influenced his future work especially his proposals for the Copper Houses in Europe and the Packaged Houses in the United States.

His papers, (Program for the Founding of a General Housing-Construction Company Following Artistically Uniform Principals), (How do we Build Cheaper, Better, More Attractive Dwellings?), (Systematic Preparation for Rationalized Housing Construction), and (The Architect as an Organizer of the Modern Building Industry and his demands on Industry) laid out several principals (Herbert, 1984)<sup>8</sup>. A summery of these principles is as follows:

- \* Industrialized building should be based on the production of standardized components that vary in qualities and materials in a manner enabling Interchangeability of these components. The production of these elements is to be carried out by subcontractors under the supervision of architects in order to lower the cost and ensure quality of production.
- \* Dwellings should be constructed in the form of elements and components utilizing factory assembly lines. Production should be monitored for quality by a team of

---

<sup>7</sup> Sullivan, “Industrialization in The Building Industry”, p.33

<sup>8</sup> Herbert, “The Dream of the Factory-Made House”, p.29-66



architects, engineers and businessmen, each having defined roles and responsibilities.

- \* Such a venture will only be considered successful if it achieves a reasonable level of individuality and adaptability to change through interchangeability of parts while maintaining the economic advantage of mass production.
- \* Architects have a responsibility towards society to help solve its acute housing problem; therefore, their involvement in this process is inevitable to assume the role of integrators of “the scientific, social, technical, and economic factors, inherent in the new architecture of the industrial age”<sup>9</sup>. If Architects dismissed this responsibility, Gropius predicted that industry would eventually assume that role on its own.
- \* While the preceding principles display the ideology of wholeness for which Gropius was renowned, he proposed that the solution to mass housing is not achieved through the design and construction of the whole housing unit but is arrived at through standardization of the housing components.

As detailed by (Herbert 1984), the first initiative for practical application of these principles was surprisingly not put forward by Gropius but by the industry. In 1930, The Hirsch Company, a German Based Corporation, was contemplating the production of modular wall panels with interior steel lining and external copper facing. The panels were to be produced at a 1 meter increment and could extend to a maximum of 4 meters with a height between 2.35 and 2.8 meters. These panels, which were to be completely assembled in the factory environment, were advertised in a catalog published alongside the panel prototypes that were presented in exhibitions displaying its virtues of:

---

<sup>9</sup> Ibid, p.64

*“...Precision, being mechanically assembled; its hygienic qualities; its efficient thermal insulation, which made it economical to heat; its proof against fire, lightening, and earthquake, and the fact that it could be erected in 24 hours and internal partitions could be relocated.”<sup>10</sup>*

The exhibitions were followed by mixed reactions. Gropius was amongst those who saw great potential in the system regardless of his reservations concerning some technical aspects and was approached to prepare material for another catalog for these panels. Gropius’ responsibilities soon extended to cover management as well as marketing issues in addition to design development of the panels and resolving of the technical problems of the first prototype.

The cooperation between Hirsch and Gropius produced several Housing options that could be generated from this panel system. Consumer demand was encouraging and led to an agreement that two of the housing options would go to production (Fig3.2). However the Hirsch Company ran into political and subsequently financial difficulties that ended this venture before production resumed in 1932.

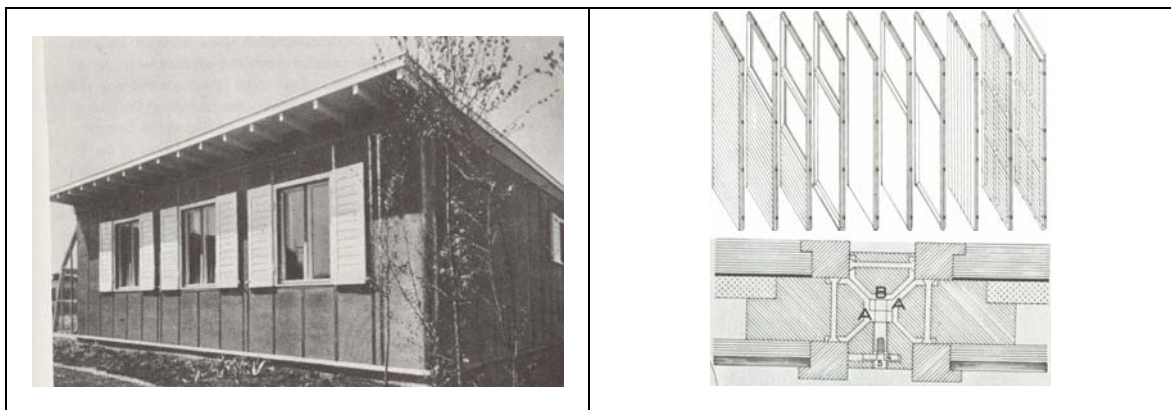

Figure 3.2 One of Walter Gropius Copper House prototypes

Figure 3.3 Panels and connection used for the Packaged House proposal

With mass produced housing still on his mind, Gropius tried once more to bring his theoretical ideas to light through his partnership with Konrad Wachsmann during his

---

<sup>10</sup> Ibid, P.112

stay in the United States in 1941. Their patented panel system, which they called “The Packaged House” (Fig3.3) followed the same principals of the Copper Panel system but differed in its use of wood as a material in 8’ by 3’4” modules and its utilization of a wedge connector that the two architects suggested would ease on-site assembly.

There was a point in which Gropius’ and Wachsman’s partnership was greatly backed by governmental as well as entrepreneurial and Industrial support. However, their attempt ended in the same manner in which it had started. Financial difficulties led to a total collapse of this supporting team in 1951 after the production of 200 units which were sold in the States, putting an end to Gropius’ serial of endeavors in this field.

#### Le Corbusier and the F.Q.M. in Pessac

Like Gropius, Le Corbusier’s work stems from his early writings and journals. His books, “Towards a New Architecture”, “Urbanisms” and principals, *the house as a machine to live in* and *the city in the park* and his interest in workers’ housing were manifested in his Domino House project in 1914 (Fig3.4) and the works that followed such as the Villa Savoy and the Unite´ d’ Habitation among several others.

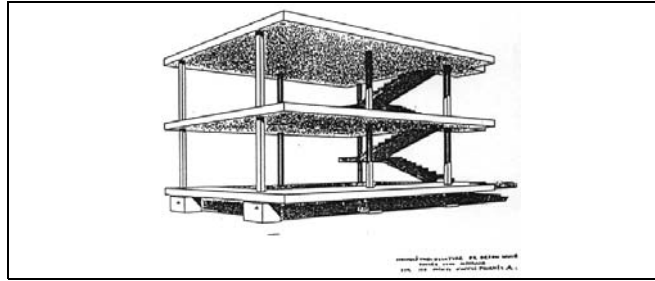

Figure 3.4 Le Corbusier's Domino House

His published articles and journals between 1914 and 1918 caught the attention of Henry Fruges, who at the time was managing a project to build 10 worker housing units in Leges for his father's sugar factory. Interested and intrigued by the ideas presented, Fruges commissioned Le Corbusier to design the project that was completed a year later.

Fruges, being a benevolent humanitarian, artist, poet and businessman, was interested in finding a solution to the mass housing issue on a larger scale and so he expressed this wish to Le Corbusier:

*"I am going to enable you to realize your theories in practice- right up to their most extreme consequences- Pessac should be a laboratory... standardization and mass-production"<sup>11</sup>*

Le Corbusier portrayed these theories as follows:

*"By slow degrees the building sites will become industrialized, and the incorporation of machines into the building industry will lead to the introduction of standard components; house designs will change, a new economy will be established; the standard components will ensure unity of detail and unity of detail is an indispensable condition of architecture beauty... Our towns will lose the look of chaos which disfigures them today... Thanks to the machine, thanks to standard components, thanks to selectivity, a new style will assert itself..."<sup>12</sup>*

---

<sup>11</sup>Jencks, Charles, "Le Corbusier and The Tragic View of Architecture", Harvard University Press, Cambridge, Massachusetts, 1973, P. 72

<sup>12</sup> Boudon, Phillippe, "Lived-in Architecture: Le Corbusier's Pessac", The MIT press, Cambridge, Massachusetts, 1972, P. 34

These Modernist concepts that evolved around elevating public taste, and provoking favorable social change and development through architecture and urban planning as well as Fruges' demand for the maximum level of variation achieved within the economy of mass-production, were the basis for the design of the Quarters Moderns Fruges in Pessac. The initial proposal comprised of 200 housing units built from standardized 5mx5m and 2.5mx2.5m concrete elements that are intermixed in different configurations and intermingled with Garden spaces, terraces and openings (Fig.3.5 & 3.6). Windows, Stairs, heating equipment, and kitchens were standardized elements nested within these variations of housing units.

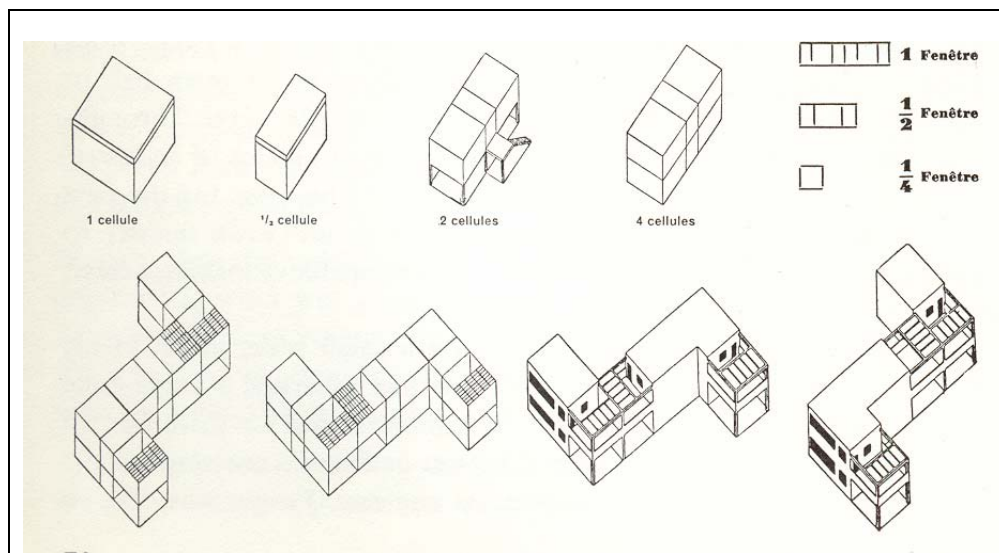

Figure 3.5 Standard modules used in Pessac

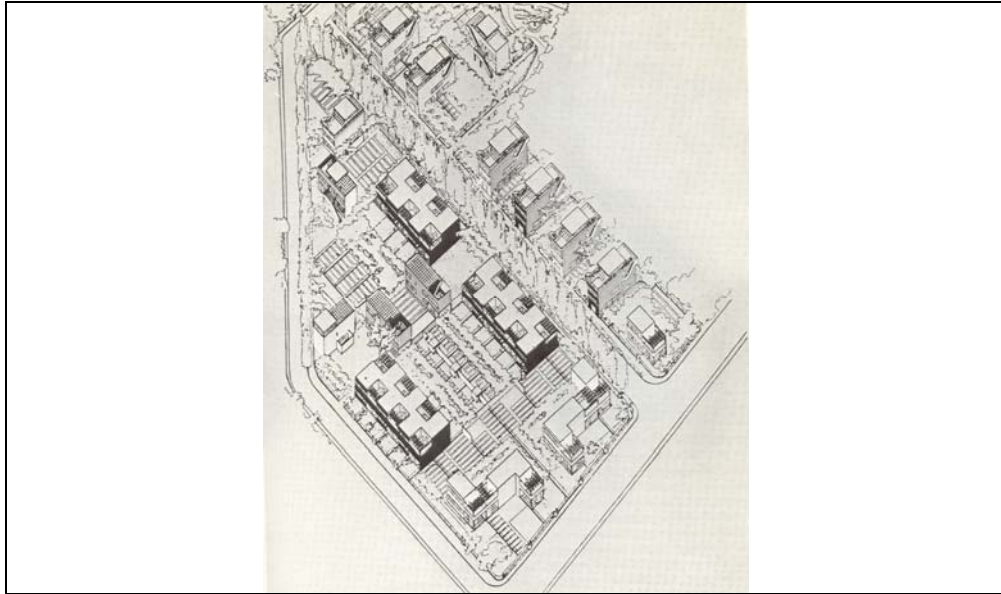

Figure 3.6 Pessac modules intermingle with open garden spaces

Culturally, Pessac was a region very much attached and nostalgic to its traditional gothic building character. Bearing that in mind, it was inevitable that Le Corbusier's proposals as devoid from decoration and ornamentation and as austere as they were, having the influences of modern architecture, came shocking to the region's residents who were prejudiced against them.

Despite the fact that Le Corbusier eventually gave in to Fruges' appeals to soften the aesthetic, which he did through color treatment of the facades, the difference in the aesthetical preferences remained a problem. Yet it was not the only obstacle that faced this project; regulations hindered the construction process and slowed it down for years. Furthermore the financial difficulties, and Fruges' fragile psychological condition, that he suffered from partially due to not succeeding in selling these units, summarizes the conclusion of this project, with the construction of only about 50 of the 200 units originally proposed rendering it a failure. Years later, Le Corbusier noted that "it is

always life that is right and the architect who is wrong,”<sup>13</sup> in comment on the manner in which the residents of Q.M.F in Pessac reacted to his imposed civility and uniformity of the dwellings by elaborate ornamentation and personalization (fig. 3.7 - 3.9).

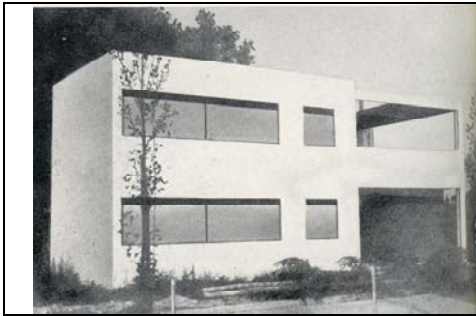

Figure 3.7 Rendered image of the housing unit in Pessac



Figure 3.8 Color treatment applied to units by painting the façade



Figure 3.9 Housing units with residents' decorations applied

### Buckminster Fuller's Dymaxion Dwelling Machine

While the residents of Q.M.F considered the project as an outrageous disconnect from culture and tradition, Buckminster Fuller viewed the work of Le Corbusier and most of the architects of that period as “trivial since it did not seek to fulfill the need for shelter from an engineering viewpoint, and without conforming to the demands of style or tradition”<sup>14</sup>. Fuller believed that “homes should be thought of as service equipment,

---

<sup>13</sup> Ibid, p. 1

<sup>14</sup> Lorraine, Loretta, “ Building Values: Buckminster Fuller's Dymaxion House in Context”, City University Of New York, 2004, P.4

not as monuments”<sup>15</sup>, he also saw that in order to fully utilize the economies of mass production, identical housing units should be manufactured as a whole in the factory and flown to their final destination. His “4D Timelock” and “Chronofile” contains detailed explanation of why and how he thought his ideas could materialize.

One of Fuller’s early proposals was the 4D Dymaxion House, a patented idea based on his set principals. The scheme involves the use of aluminum as a building material, as it was a common element in nature, highly durable, having a long lifespan, and required little or no maintenance. That, in addition to it being recyclable, justified its use despite its high-energy cost. In terms of form, to enable economy in material, the house was circular in concept but was translated in his drawings to a hexagon (Fig.3.10&3.11) and appeared on the patent documents as a square in order to avoid complications in the patenting process as Fuller’s attorney suggested. The house, which was supported by a central mast and tension cables, was not the first when it came to the use of metal at the time, but was the precedent in terms of utilizing it to its fullest potential as a tensile structural material.



Figure 3.10 Model of Fuller’s 4D Dymaxion House

---

<sup>15</sup> Baldwin, J., “BuckyWorks: Buckminster Fuller’s Ideas for Today”, John Wiley & Sons Inc., 1996, P.16



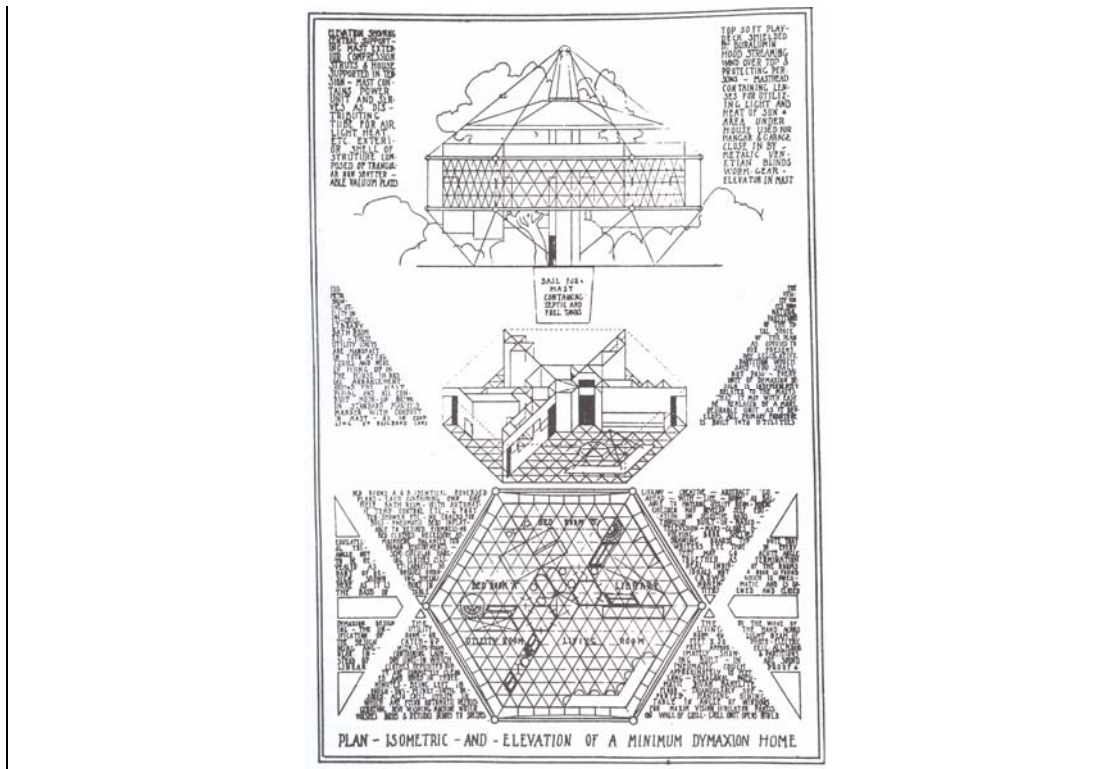

Figure 3.11 Plan, section and elevation of the 4D Dymaxion House

Only one full-scale prototype of the 4D Dymaxion House was built and used as a display for a furniture exhibit organized in Chicago in 1929<sup>16</sup>. Neither the Company organizing the exhibit nor Fuller had any intention of putting this house into production for Fuller realized that both the materials and the production environment required to ensure high performance are not readily available at an affordable price at that time. He also considered this proposal to be at its early gestation stages.

Although he was conscious of the need for development and refinement of his proposals, Fuller did not cease to explore opportunities to approach the industry and explore means of production. His experience in the Navy as a mechanic and engineer as well as his background in business, marketing and management which he acquired during the time he spent with Stockade, a company he helped establish with his father-

<sup>16</sup> Robert, Marks. "The Dymaxion World of Buckminster Fuller", Reinhold Publishing Corporation, 1960, P.24

in-law who was a renowned architect, proved very helpful as he was able to take advantage of the prevailing circumstances during World War II in a way that Gropius failed to do.

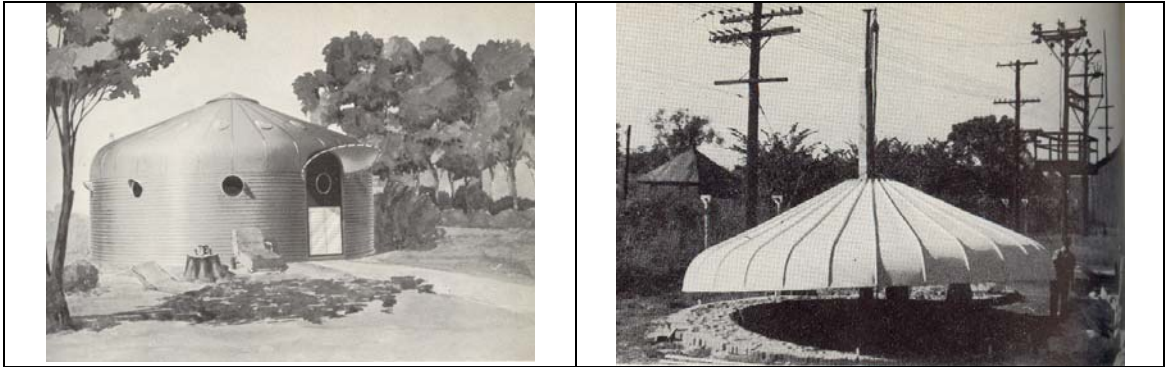

Figure 3.12 The Dymaxion Deployment Unit

Figure 3.13 Mast supporting DDU structure

When Buckminster first came across the galvanized steel bins produced by Butler Manufacturing Company for grain storage, he recognized their potential to be used as emergency shelters and contacted the company to negotiate production of his Dymaxion Deployment Unit (DDU) (Fig3.12). Like the grain storage structures, the DDU was manufactured using galvanized steel, but the conical shaped roof of the grain storage was substituted with a roof having a curved edge to better withstand high winds and the strain resulting from the mast-hoisting process involved in its assembly. The deployment unit was constructed from the roof down using a temporary mast in the center of the unit (Fig3.13), a methodology that Fuller used for his housing structures proposing that it would ease construction and reduce injuries. The units' utilitarian image and building code issues were obstacles for it being used as civilian housing, however the desperate need for temporary war housing units for the armed forces deemed them as the ideal product for such a market. Hundreds of units were sold to

the military during the war before they were designated low priority due to lack of funding, thus stopping production.

Although Fuller had already built a larger modified prototype to explore the use of the DDU as a family housing unit, he was conscious of the obstacles that would prevent its production and consequently did not pursue this proposal any further in favor of devoting his effort to working on his next project, the Dymaxion Dwelling Machine.

The Dymaxion Dwelling Machine, which was later known as the Wichita house, combined the principals of his early 4D Dymaxion House and his experience in production of the DDU. Once again Fuller was able to take the circumstances following the war to his advantage. In 1945 Beech Aircraft Industries was facing difficulties convincing its employees, who did not see any prospect for the manufacture of bombers in the post war years, to stay with the company and thus it ordered two Dymaxion Dwelling units to be manufactured in its factory (Fig.3.13).

While this solved Beech Aircraft's problems, it also proved beneficial to Fuller who was able to utilize the advanced manufacturing technologies of the aircraft industry in the production of the first two 36-foot diameter prototypes. After Beech Aircraft exhibited the Dymaxion Dwelling, and as the shock resulting from its unorthodox aesthetic was eventually overcome, the company received several orders and was eager to carry on production further, but Fuller was reluctant as he saw that the unit was in need of development to solve its technical problems and needed seven more years for further refinement. Though the venture ended, and production stopped following the differences in views between Fuller and Beech Aircraft Company, the two prototypes were sold to a Kansas Businessman who merged them to build his residence in Wichita, Kansas (Fig.3.14 & 3.15). In the summer of 1992, the Wichita House was dismantled by a team of specialist who marveled at the durability of materials used yet

recognized several problems related to improper installation and technical issues as Fuller had pointed out about 50 years earlier.

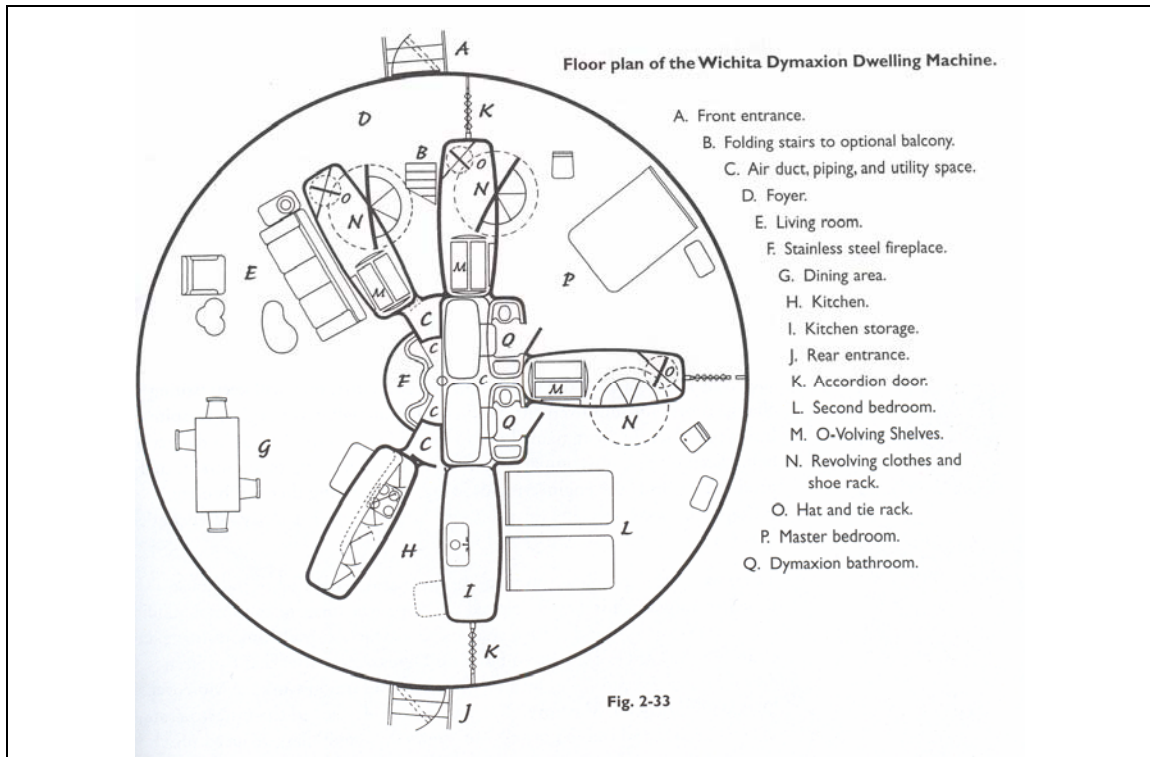

Figure 3.14 Plan of the Dymaxion Dwelling Machine

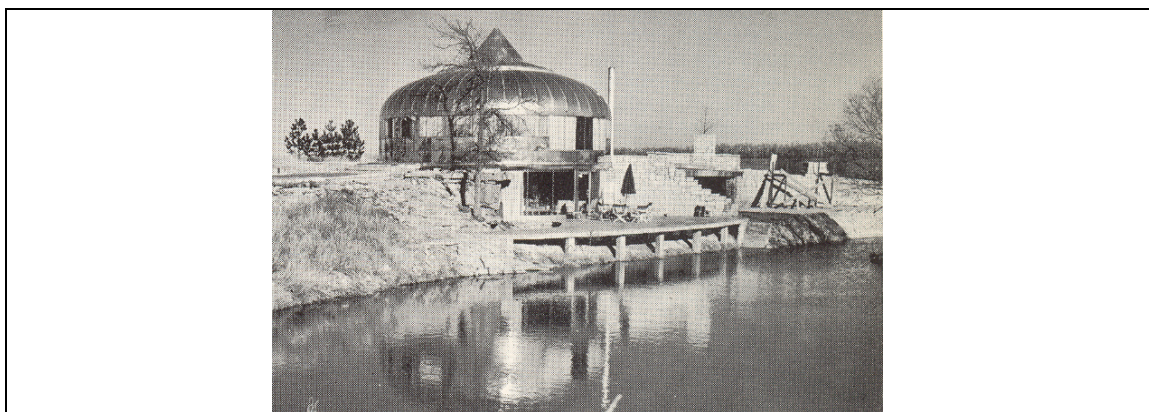

Figure 3.15 Wichita House

## Jean Prouvé's Tropical House

Though not an architect or an engineer, Prouve played a vital role in the field of industrialized building and specifically mass housing. His background as a craftsman, artist and industrial designer served as a rich and unique base from which his work and process philosophy stemmed. Prouve expressed:

*"I think I was naturally influenced by the passionate interest I had in aeronautical engineering, and it led me to ask myself why such techniques should not be used in building construction. I had the idea very suddenly! Why isn't building construction developing in the same direction as automobiles and aircraft construction? Why do the building methods of the Middle Ages still persist? I had already realized that construction was no longer genuinely medieval, but faked, and that they were beginning to create a decoration and an architecture that I did not like. That was very clear to me."<sup>17</sup>*

Prouvé's interest in industrialized mass housing compelled him to seize political, social and cultural circumstances to his advantage. Not an architect himself, he often teamed with architects in this field. These collaborations included working with Le Corbusier in some aspects of Unite d'Habitation, as well as Chandigarh.<sup>18</sup> He also collaborated with architects Eugene Beaudouin and Marcel Lods in 1938 and 1939 to design a prototype for a demountable 3.3x3.3 m steel vacation house following the French government's announcement of the initiation of paid vacations for workers (Fig3.16). The house prototype was presented in the 6<sup>th</sup> Exposition de l'habitation in 1939. Though it impressed the visitors, no orders were placed and no further units of this prototype were produced.<sup>19</sup> This collaboration did however lead to another partnership between Beaudoin, Lods and Prouve which extended to 1944 as they designed a prefabricated metal house of which a 1/10<sup>th</sup> scale prototype was presented

---

<sup>17</sup> Sulzer, Peter, "Jean Prouve; Highlights 1917-1944", Birkhauser, 2002, P.17

<sup>18</sup> The Tropical House Webcast, " Jean Prouve: A tropical House" May 30<sup>th</sup>, 2006, [http://www.architecture.yale.edu/tropical\\_house/essay.htm](http://www.architecture.yale.edu/tropical_house/essay.htm)

<sup>19</sup> Sulzer, "Jean Prouve; Highlights 1917-1944", p.138

in the 1945 Exposition de la Reconstruction held in Paris (Fig 3.15), however, leading to no further commissions or orders<sup>20</sup>.

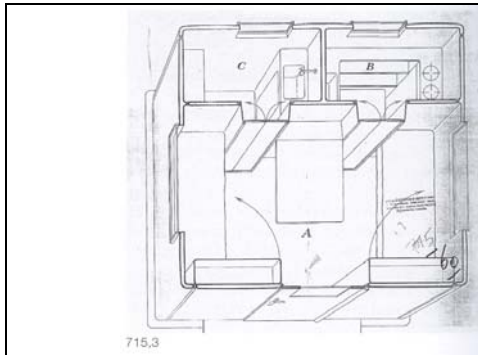

Figure 3.16 Plan of the demountable steel vacation house

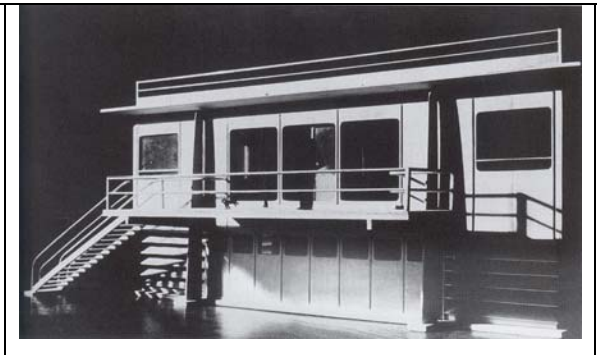

Figure 3.17 1/10<sup>th</sup> scale prototype of the demountable metal house

Concurrent to Prouve's collaboration at that period, he saw in the growing need for housing for the army during WWII an opportunity to further explore his ideas. Thus in 1938 he submitted a proposal for a competition to design a demountable barrack unit for the French Ministry of Aviation. His proposal was basically a 40 x 8m building with a height of 3.5 m. The proposal was presented in two structural variations, the first, a central portal frame structure and the second, an external frame<sup>21</sup>. Though the proposal itself did not create much impact as a competition entry, the two structural proposals formed the base for Prouve's following project when he was commissioned a year later in 1939 to design and fabricate 20 demountable barrack units for the French engineer corps. The units were to accommodate 12 individuals and to facilitate assemblage in no more than a few hours. Prouve designed the combat units in 3 size variations, 4x4m, 4x6m and the largest at 4x12m. Following the presentation of the

---

<sup>20</sup> Ibid, p.147

<sup>21</sup> Ibid, p.144

prototype and the 3 hour assembly process, nearly 500 units were ordered<sup>22</sup> during the war.

This success set the guidelines upon which Prouve's following prefabricated postwar housing projects were designed. These guidelines include the use of an internal portal frame structural system and utilize flat sheet metal to produce wall panels in order to facilitate ease of packaging and transportation. An opportunity to test these principals was posed when in 1949 Prouve was given a contract by the Ministry of reconstruction and Urbanism to build 14 lot subdivisions in an effort to demonstrate his ideas for lightweight prefabricated metal housing systems<sup>23</sup>. In that same year, ideas to export housing units to government officials posted in Africa were put forward and Prouve was engaged in the project through his collaboration with architects Her'be and Le Couteur<sup>24</sup>. The result was the design of the Tropical house which was based on a one meter grid system utilizing Prouve's internal structural system and his flat components principle to ensure the efficient packaging and transportation inside the hold of a cargo plane (Fig 3.18 & 3.19). The house was entirely fabricated from aluminum except for its largest structural components. It incorporated several ventilation and sun shading devices and strategies to help alleviate the harsh weather condition in African territories. Further, attention was paid to keep the number of parts to a minimum which is a design principle influenced perhaps by the Prouve's industrial designer's mentality as seen in all his works.

Three units of this proposal were fabricated, shipped to, and assembled in Africa; one in Niamey in Niger and two others in Brazzaville in Congo. Yet despite its

---

<sup>22</sup> Ibid, p.152

<sup>23</sup> Hammer Exhibitions, "Jean Prouve; A Tropical House", May 30<sup>th</sup>, 2006  
<http://www.hammer.ucla.edu/exhibitions/95/>

<sup>24</sup> Sulzer, "Jean Prouve; Highlights 1917-1944", p.155

originality, this proposal failed to achieve the financial edge that is assumed to be associated with industrial production as it was by far more expensive than housing units produced locally<sup>25</sup>. Moreover it failed to address the aesthetic appeal of its targeted residents who were mainly French bureaucrats and entrepreneurs, thus leading to no further orders<sup>26</sup>. A similar fate awaited the fate of the commission of housing subdivisions. This serious of disappointment consequently led to financial difficulties that eventually resulted in Prouve's loss of the ownership of his Workshop, Thus putting an end to 3 decades of attempts in the field of industrialized mass housing<sup>27</sup>.



Figure 3.18 Exterior view of the Tropical House



Figure 3.19 Interior view of the Tropical House

---

<sup>25</sup> Hammer Exhibitions, "Jean Prouve; A Tropical House", May 30<sup>th</sup>, 2006  
<http://www.hammer.ucla.edu/exhibitions/95/>

<sup>26</sup> Ibid

<sup>27</sup> The Tropical House Webcast, " Jean Prouve: A tropical House" May 30<sup>th</sup>, 2006,  
[http://www.architecture.yale.edu/tropical\\_house/essay.htm](http://www.architecture.yale.edu/tropical_house/essay.htm)



## The 60's

### The Archigram Group

As a protest against the traditional influences that disfigured the Modern style in the late 1950's, the Archigram Movement emerged dominating the architectural scene in the United Kingdom in the period between 1960's and early 1970's. Its ideas being based on the spirit of change both social and technological, a combination the group proposed would eventually stimulate architecture that is better equipped to address the needs of contemporary life. The US critic, Michael Sorkin, defined the movement as one that is:

*"Bewitched by nomadic fantasies" it "argued that an architecture based on mobility and malleability could set people free... this notion of consumer choice combined optimized technology, a post-Beat hitchhiker's sense of freedom and the giddy styles of customization found in Detroit."*<sup>28</sup>

This spirit is vividly sensed in Archigram's projects that dealt with urban planning and the housing issue. The living city, the plug in city (Fig.3.20), the walking city (Fig.3.21), the blowout village, and the instant city are some of their concepts that incorporated the use of modules or living units. Some of their proposals for these modules were the capsules (fig.3.22), living pod (fig.3.23), cuishicle and their proposal of the 1990 house.

Given the radical nature of ideas and projects proposed, it is not a surprise that these projects never left the stage of ideation and conceptualization. Ron Herron a member of the Archigram group expressed this in 1994:

"Archigram gave us a chance to let rip and show what we wanted to do if only anyone would let us...they didn't."<sup>29</sup>

---

<sup>28</sup> Design Museum, Archigram, Nov, 18th '05, <http://www.designmuseum.org/design/index.php?id=87>

<sup>29</sup> Ibid

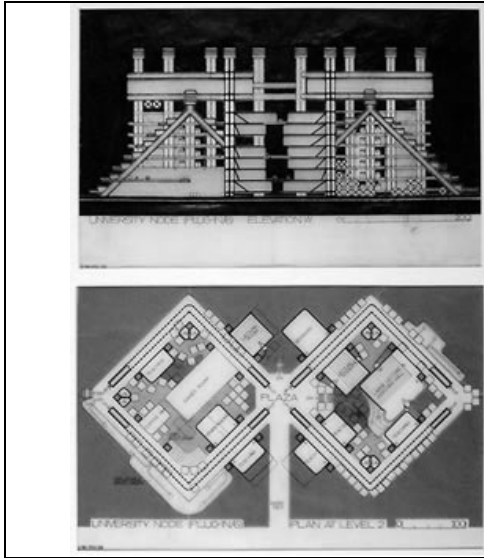

Figure 3.20 Plug-In City



Figure 3.21 Walking City

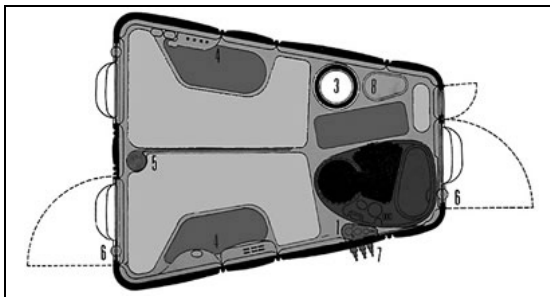

Figure 3.22 Capsule

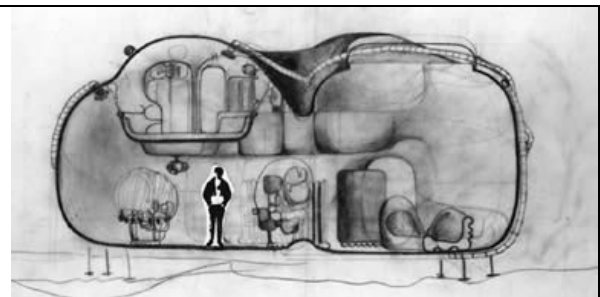

Figure 3.23 The Living Pod

### Moshe Safdie and Habitat '67

Moshe Safdie's Thesis design project (A 3-Dimensional Modular Building System) and his report (A Case Study for City Living) were perhaps influenced by the same social values of the 1960's that were promoted by the Archigram at that same period. Safdie's work was focused around housing and urban Design in High-density areas and proposed:

*"The combined use of a three-dimensional urban structure, specific construction techniques (the prefabrication and mass-production of prototypal modules), and the*

*adaptability of these methods to various site conditions for construction conceivably around the world”<sup>30</sup>*

The ideas presented in his thesis were the basis for Habitat '67 (Fig.3.24), the main pavilion constructed for the 1967 International World Exposition in Montréal. The structure evolved around the construction of the 354 rectangular concrete modules each exactly 12 m x 5.33 m x 3 m in dimension (Fig. 3.25). The modules were cast on site and sand blasted forming 154 housing units that were assembled in 16 different configurations (Fig. 3.26) using a crane to lift the modules into position on a hill shaped structure supported by high-tension steel rods, cables and welding (Fig. 3.27).



Figure 3.24 Habitat '67

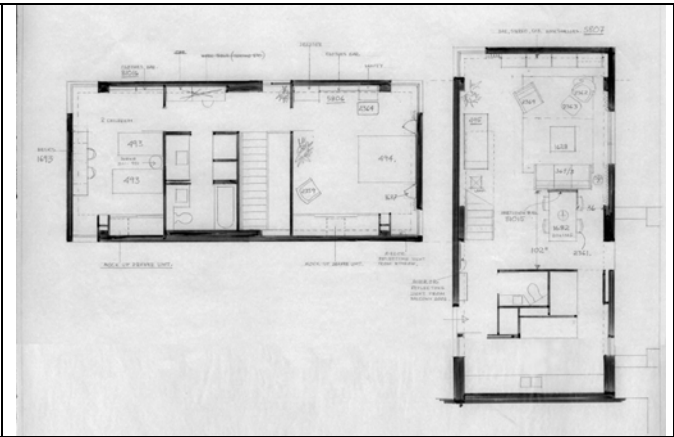

Figure 3.25 Plan of rectangular module

---

<sup>30</sup> The Moshe Safdie Hypermedia Archive, Concept, Nov 18<sup>th</sup>, '05  
,<http://cac.mcgill.ca/safdie/habitat/concept.htm>

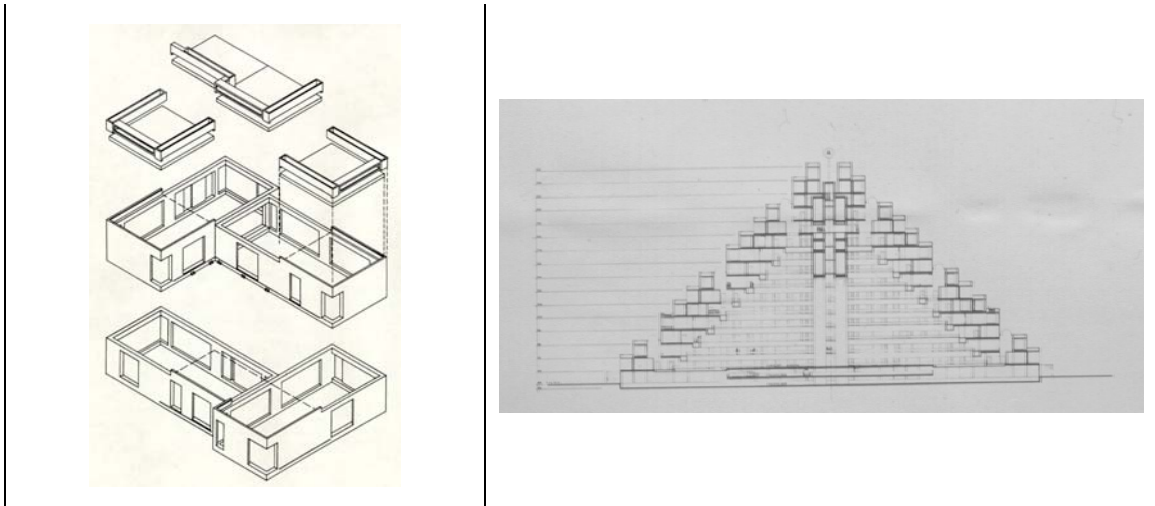

Figure 3.26 Module configuration

Figure 3.27 Cross section of the triangular frame supporting the rectangular modules

The project was a success in spite of issues regarding the weathering of concrete in the cold climate and the expenses required for the annual maintenance needed, which Safdie addressed in subsequent studies by reducing the stress on the modules through using different geometries for the modules. Following the positive feedback several Habitats were planned to be constructed worldwide namely in New York, Puerto Rico, Israel, Rochester, and Tehran. Each of these projects was to follow the same set of principals exhibited in Habitat '67 yet adapted to fit the existing conditions of each different site. Regardless of the effort invested into these proposals, none of them was constructed. As to why these projects did not materialize, Safdie commented that:

*“Habitat was...built in a world fair out of the context of the system... it was built to demonstrate certain ideas but it did not have to confront the system; neither the building trade unions; neither the building codes; neither the housing economics; none of them really had to be confronted...Years after, where I thought that everything would be easy having done that... I realized that there were many key issues that Habitat brought... to confrontation and that dealing with these issues... has become the central preoccupation of my work.”*<sup>31</sup>

---

<sup>31</sup> Ibid

## Paul Rudolph's 1968 Ventures

Paul Rudolph's interest in housing is clearly demonstrated by the series of over 80 housing units designed and built in the period between 1946 and 1980, the majority of which were known as the Florida houses, where Rudolph first started his practice. The shift from the design of conventional housing units to prefabricated housing was gradual as Rudolph slowly introduced prefabricated building components such as girders and sliding doors in his housing designs before incorporating entire mobile home units in his projects in 1968. Though this shift could be considered a natural result of the teachings of Walter Gropius of whom Rudolph was a graduate student during the time he spent at Harvard, it may be also attributed to the influences of the prevalent modernist believe during that period, that urban design could bring about favorable social change.

Rudolph conceived many urban projects, both in the form of conventional apartment buildings and projects based on the "plug-in-city" concepts which were promoted in the 60's by the Archigram and metabolism movements, yet were long before that, depicted in Rudolph's sketches dating back to the 1950's<sup>32</sup>. These concepts depended on the utilization of prefabricated mobile units, which Rudolph referred to as the "Twentieth century brick"<sup>33</sup>. These units were plugged into a larger central core that houses all the necessary mechanical, electrical, and plumbing services<sup>34</sup>. The majority of Rudolph's projects that incorporated the use of mobile housing units remained un-built however.

---

<sup>32</sup> Monk, Tony, : *The Art and Architecture of Paul Rudolph*, Wiley Academy, 1999, P. 69

<sup>33</sup> The Daily Telegraph, "Storey With an Unhappy Ending; Paul Rudolph's Graphic Arts Center, New York, New York", The Daily Telegraph Limited, 1968.

<sup>34</sup> Monk, "The Art and Architecture of Paul Rudolph", p. 69

Perhaps the most renowned of these unrealized ideas is the Graphics Arts Center in New York, which was proposed between 1967 and 1968. The complex was to include 4,050 prefabricated residential units in addition to a car park area, 13 floors of offices, nurseries, an elementary school, restaurants, shops, and a swimming pool in addition to other services. The project was in essence similar to Safdie's Habitat concept yet was an improvement in terms of utilizing 3in thick sheet steel for the floors, walls and roofs instead of poured in concrete<sup>35</sup>. Structurally, the units were hanged from the central cores rather than stacked as was the case in Habitat thus further alleviating structural support issues (Fig 3.28).

Regardless of the fascination of the lithographers' union by this proposal and their willingness to invest a total of \$ 280 million to see it materialize, objections raised by the New York building trade unions halted this project. As nearly 3 quarters of the cost of the project would have eventually poured into the mobile industry with factories mostly situated outside New York in the Midwest and Southern states, New York building unions saw this venture as an attack on their business.<sup>36</sup>

---

<sup>35</sup> Ibid, p. 70

<sup>36</sup> The Daily Telegraph, "Storey with an Unhappy Ending; Paul Rudolph's Graphic Arts Center, New York, New York", The Daily Telegraph Limited, 1968.

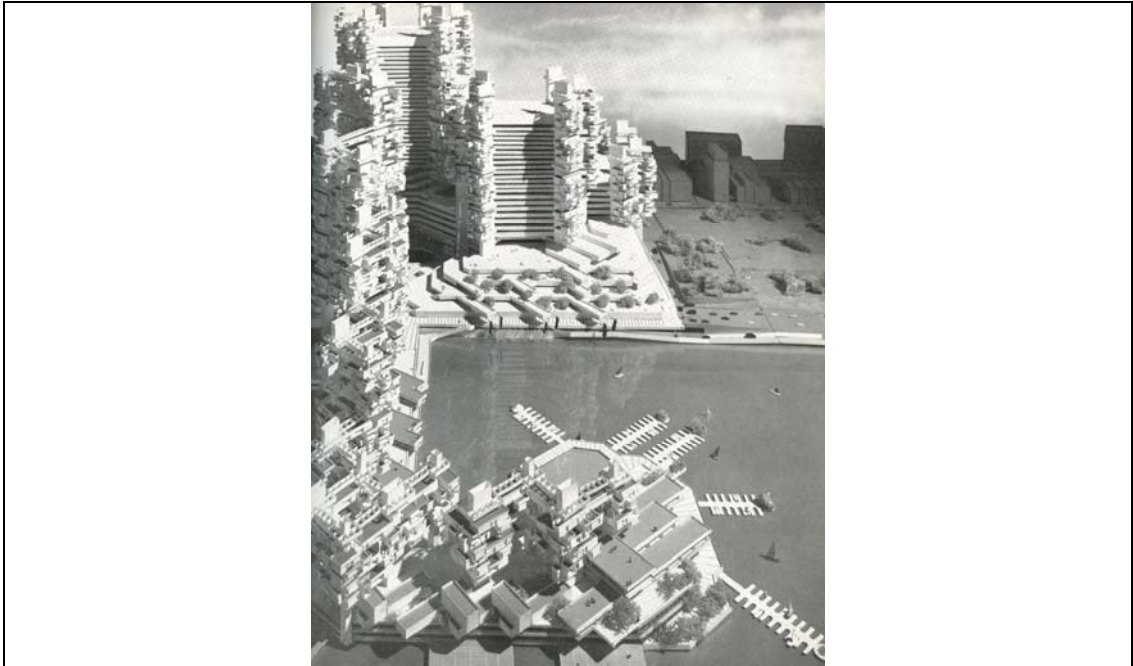

Figure 3. 28 Paul Rudolph's Graphic Arts Center proposal, New York, New York

In comment on the fate of this project, Rudolph expressed:

*"Architects have to be eternally hopeful people. I never believe anything is going to be built until it is actually in place. But in this profession you learn to work on two levels - on one level are the things you know will be built; on the other are the things you know are inevitable, that will be built in 20 or 25 years' time, but which you start with the knowledge that disappointment is built-in. Sometimes the two transfuse each other. There are elements of one in the other. I could have designed this particular building in a completely different way so that it would unquestionably have been built."*<sup>37</sup>

Following this attempt, Rudolph designed a number of projects which may be considered more modest versions of the Graphics Arts Center, utilizing the "twentieth century brick" to create low cost housing communities. One of these well known attempts is the Oriental Masonic Gardens in New Haven, Connecticut (Fig 3.29).<sup>38</sup> This project which consisted of 148 housing units was funded by a 3.5 million dollar HUD

---

<sup>37</sup> Ibid

<sup>38</sup> Ibid

mortgage. The units, which were factory assembled, were fitted with all electrical wiring, plumbing and finishing necessities before delivery to site where they were grouped in clusters of four around a central core. The module in the ground floor contained the living space whereas a second module placed above the first houses the bedrooms and baths and a third module may be added on top parallel to the one below. The modules were 12 ft wide by 27, 39 or 51 ft long and cost \$17 per sq. ft. The cost of a single housing unit was between 21,000 and 23,000.<sup>39</sup>



Figure 3.29 Oriental Masonic Gardens housing project in New Haven, CT 1968

Several obstacles surfaced during construction. In light of the booming mobile home industry at the time, it was very challenging to get investors interested in taking part in the venture. Furthermore, as the prefabricated modules were not transported on a chassis, they were, by code, subject to inspection following installation. The costly problems that emerged during inspection as a result of transportation had a negative effect on the anticipated economic advantage of factory production. Although a number of units were actually constructed, they were eventually uninhabitable and were demolished in 1981.

---

<sup>39</sup> Manufactured Housing; A Double Wide Analysis, "Precedents", May 30<sup>th</sup>, 2006



## Kisho Kurokawa and the Metabolism Movement

The underlying theoretical basis for the metabolism movement are perhaps best captured in Kurokawa's "Capsule Declaration" which was published in SD "Space Design" Magazine in its March 1969 edition summarizing Kurokawa's studies that were initiated in 1959. In his article, Kurokawa argued that capsule architecture would eventually transform architecture, liberating it from conventional constraints and enabling it to benefit from the advantages of industrialization and mass production as did the aircraft and automotive industry. He further emphasized that a major pitfall of the building industry, is its focus on prefabricating building components primarily to reduce cost, reduce construction periods and to unify quality without any consideration given to the interchangeability of the parts. He further clarifies that through the mass production of capsule units that house different functions; such as baths, kitchens or living quarters<sup>40</sup>;

*"...Unique and highly individualistic houses can be assembled by putting together functional units in whatever way the owner chooses. Great variety will be made possible through assembling mass-produced units in different ways. Such a new stage of prefabrication is one step beyond the industrialization, and its aim is to produce space which will react sensitively to the changes in people's lifestyles. The new system, which may be termed a selective mass-production, will enable us to require a new form of housing and adapt to the technetronic society."<sup>41</sup>*

Kurokawa's prefabricated apartments proposal was published in 1962 as a manifestation of his ideas (Fig 3.30). These concepts along with the proposal were further developed to materialize in the form of the Takara Beautillion in the Osaka World Exposition in 1970 and later as the Nagakin Capsule Tower that was built in 1972.

---

<sup>40</sup> Kurokawa, Kisho, "Metabolism in Architecture", Westview press, 1977

<sup>41</sup> Ibid", p.83

In the Takara Pavilion (Fig3.31), a single prefabricated structural system that utilizes steel pipes bent to 90 degree angles, was repeated 200 times to form the supporting skeleton. This skeleton, which supports the functional stainless steel capsule units, is expandable depending upon the number of capsules to be incorporated and also flexible as it could support several different configurations. Although the pavilion, did not fail to impress visitors and critics in the exposition, it was criticized when it came to its failure to deal with the provision of services in an aesthetically pleasing manner.

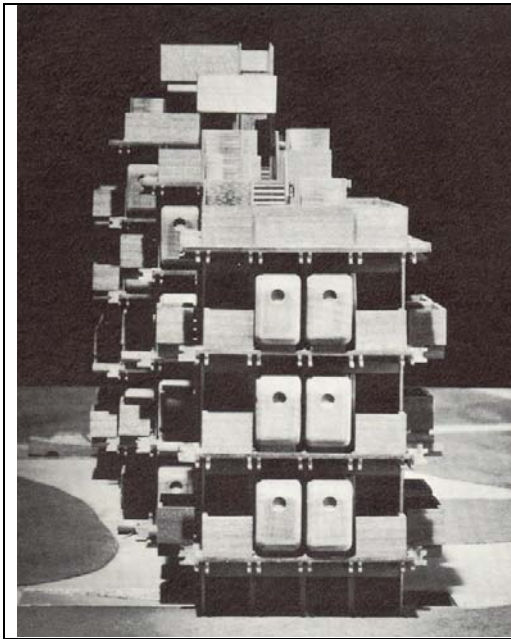

Figure 3.30 Prefabricated apartments



Figure 3.31 Takara Beautillion

The Nagakin Tower was envisioned mainly as a hotel or a cluster of capsule housing units for individuals in constant travel such as business men and artists in need for accommodation during their frequent yet short visits to the city of Tokyo. However it was also seen that the concept of the capsule utilized, if given different functions, has the potential to be used as single family housing units.

The tower was comprised of two elements. Two steel and reinforced concrete towers, constructed on site and the 144 prefabricated capsule units. The towers house the elevators, piping, wiring and services that feed the capsules. Each capsule is attached by 4 high tension bolts to the exterior tower providing the flexibility of repositioning the capsule unit independently from the other units attached to the structure (Fig 3.32). Due to restrictions in the factory production process, the size of the steel panels used for capsules was restricted to a maximum of 1.2 x 2.3m. Constraints were also confronted during the process of transportation of the capsule units to the cramped construction site eliminating the possibility of storing the capsules on site until they are attached to the tower. Nevertheless careful planning of the delivery of the units to site ensured that all units delivered are fixed in place in the same day. The capsules were attached to the structure at a rate of 5-8 units a day and all work was completed in 30 days (Fig3.33).

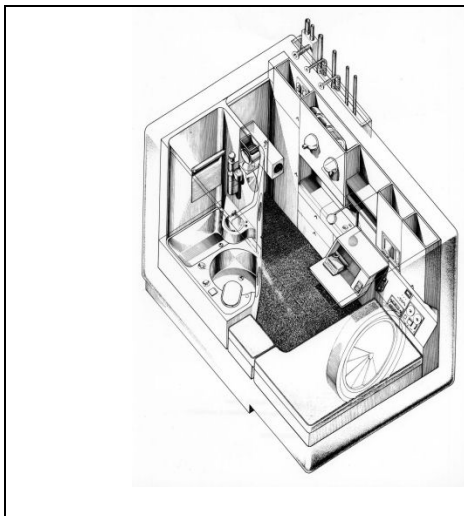

Figure 3.32 Capsule interior layout



Figure 3.33 Nagakin Tower

Although major decisions related to both the exterior and interior of the capsules was fixed, personalization of the capsule was facilitated by offering the purchaser a

choice of interior finishes, color scheme as well as the option of equipment to be included within the capsule. Furthermore, changes in the positioning of interior of furnishings as well as in anchoring the unit to the tower result in several variations. However not all these possible combinations were used in the Nagakin Tower as the number of capsule units used in the project was limited to 144 and the possible variations of interior finishes and optional elements were not all produced or marketed at the time of construction and fabrication.

Though the capsules were intended to be Interchangeable and moveable to different locations, difficulties arising due to their bulky size and the congested surrounding area formed obstacles eliminating such options. Furthermore, as the capsules were never changed or maintained in the 33 years that followed its construction several performance problems are arising which led the occupants to ask for the demolition of the structure.<sup>42</sup>

### **The Turn of the Century**

As more architects continued to explore options for mass housing and as architecture magazines and websites, some of which solely devoted to this field, continued to display different concepts and ideas (Fig 3.34-3.36); there was another group who decided not to get caught up in this chase but rather to directly answer to the housing needs the traditional “old-fashioned” way. Perhaps it was the realization of the severe and urgent need to address the housing crisis of the growing number of poor and homeless, or perhaps it was the realization that the search for the mass produced solution might take longer than they or people in need for housing solutions could afford to invest given the uncertainty that such time and effort, if devoted, will be at all

---

<sup>42</sup> Acrspace.com, Kisho Kurokawa Nagakin Capsule Tower, June 2<sup>nd</sup>, 06, <http://www.arcspace.com/architects/kurokawa/nakagin/nakagin.html>

fruitful, that drove this group to such a direction. Whatever the reason behind their inclination, it definitely set this group apart.



Figure 3.34 Take Home Prefab by Jennifer Siegal's Office of Mobile Design

Figure 3.35 Quik Home by Adam Kalkin



Figure 3.36 Kithaus by Tom Sandonato and Martin Wehmann

One of these most renowned architects, driven purely out of a sense moral and humanistic responsibility, was Samuel Mockbee, who in 1991 left a thriving practice, to establish in 1993 what is known today as the Rural Studio. The studio is an architecture program at the Auburn University's college of Architecture, in which students, faculty, and funding organizations help build houses for the residents of Hale County, Alabama, a region famous for the extreme poverty of its residents.

At a time when architects were exploring with standardization of housing units and the use of computer technology in production, Mockbee and the Rural Studio were

designing custom housing solutions for their clients and personally constructing what they designed using donated material. These materials that ranged from car tires, old license plates, and windshields to cardboard bales, recycled metal, used timber, and cement; produced a unique aesthetical character for each building constructed. In the period between 1993 and 2003, the rural studio had completed nine houses, averaging around one to two years per project<sup>43</sup>.

Though Shigeru Ban may have differed from Mockbee in that his efforts were mainly concentrated on the provision of emergency housing following natural and man-made disasters, as opposed to permanent housing for the poor, Both Ban and Mockbee shared, to an extent, the moral responsibility as a driving force. Ban saw that one of the major changes that the industrial revolution brought in architecture was the emergence of the masses, upon their move and settlement in cities, as clients that architects have to cater to. He also considered that while earthquakes and floods are called “natural disasters,” the catastrophic consequences following these phenomena are man-made resulting from excessive deforestation and the irresponsible building attitudes of architects<sup>44</sup>. Thus he saw it the architect’s role to tend to housing the displaced due to natural calamities.



Figure 3.37 Ban’s emergency housing in Kobe, Japan 1995

---

<sup>43</sup> Rural Studio, Completed Houses, Nov, 23<sup>rd</sup>, 05, <http://www.ruralstudio.com/completehouses.htm>

<sup>44</sup> Asia Source, Viewpoints, Nov, 23<sup>rd</sup>, 05, <http://www.asiasource.org/arts/shigeruban.cfm#videoclips>

His work in this field started in 1995, following the earthquake that hit the town of Kobe in Japan, Ban's proposed shelters (Fig. 37) were set on rented beer crates that served as a foundation for cardboard tubes that were 106mm in diameter and 4mm in thickness. The structure that was roofed with tenting material cost less than \$2000.

As illustrated by his emergency shelters in Kobe, Ban's ideas evolved around the use of easily obtained material in an innovative and unprecedented way to form structure and a construction system. His proposal that was used in Kobe was again utilized following slight modifications in Turkey, following the 2001 earthquake in India and following the 2004 Tsunami in Sri Lanka.

## **Conclusion**

The contributions and efforts invested towards the industrialization of mass housing in the past century are by no means restricted to the architects listed above. Others such as Frank Lloyd Wright, Mies Van Der Rohe, Robert Venturi, Paul Rudolf, and Richard Neutra among many others are well-established figures in this field. However, the preceding outline does give an idea of the massive amount of thought, time, funding, and effort devoted towards the realization of this goal.

While each of these contributions had a driving force; some were compelled by the challenge and excitement of exploration, others by the promise of fame and recognition, a few by the expected financial outcome, and many by a genuine humanitarian sense of duty and responsibility, they all shared a common factor. For one reason or another, the mass production of housing units remains an elusive dream yet to be materialized regardless of the investment.

The preceding overview reveals several obstacles which have stood in the way of these efforts. In many cases it was the lack of funding and a failure to establish a fruitful collaboration amongst architects, engineers, and businessmen; in others it was

unfavorable political circumstances and regulatory barriers. As these problems may not always be within the architect's design and control, there are others which lay well within the boundaries of the profession. Such problems evolved around the technical development of the housing units to achieve an adequate level of performance and the design for diverse and constantly varying residents' appeals while maintaining the economical advantage of mass production.

In the meantime, and as many architects persist to chase this dream and struggle with these obstacles, the housing needs of the masses remain to be tended to in a one-off custom manner demanding time and financial ability. Given that the likes of Mockbee and Ban are a rare few with an influence geographically restricted to defined regions, housing alternatives for those with no such financial resources has become a long-lived dilemma.



## **Key Points**

- Architects' interest in housing the masses did not emerge until the 20th century following the industrial revolution and the technological developments that followed. Before that, housing needs of the public were addressed by the indigenous.
- Since houses may be considered the ultimate commodity in architecture, many architects experimented with the application of the principals of mass production in the field of mass housing.
- Walter Gropius' two attempts; The copper house and the packaged house were confronted with financial and political.
- Le Corbusier, QMF in Pessac collided with regulations in addition to the lack of appeal for its aesthetic leading to financial obstacles that ended the venture.
- Buckminster Fuller's attempts; the 4D Dymaxion, the DDU and the Dymaxion Dwelling Machine faced some initial controversy regarding its aesthetic, which was gradually overcome, yet these attempts ended due to lack of supporting production technologies as well as to restrictions of material use due to political circumstances.
- Jean Prouve's early ventures led to the Tropical house which failed to address the aesthetical expectations of its residents and their financial demands.
- The Archigram failed to realize any of its housing projects due to their shocking aesthetic at the time, and due to lack of investors who are interested in serious collaboration efforts.
- The serial of Habitat projects designed by Moshe Safdie never went beyond the initial exhibition due to obstacles posed by regulations, and the dwindling investors' interest.

- Paul Rudolph's early mass housing attempt the Graphics Arts Center was confronted by political obstacles despite its optimistic start. His later project, the oriental Masonic Gardens failed to maintain the economic edge necessary for it to compete in the housing market due to unforeseen expenses resulting from complications of transportation.
- Kisho Kurokawa put the Metabolism Movement's ideas in practice through his Nakagin Tower. Though the project was initially well organized and welcomed by the public, the impracticality of the project's ideas that address interchangeability of its components led to calls for the demolition of the structure.
- The amount of efforts and resources put forward for the cause of mass housing is huge, however all these efforts failed to realize their goal as they encountered several obstacles, some of which not directly within the architectural domain such as establishment of a coherent collaboration effort and political and regulatory restrictions.
- Other obstacles within the architectural domain relate to lack of needed technological developments to address the performance of the housing unit as well as a need to maintain aesthetical appeal and a provision for a sense of variation and customization.

## CHAPTER IV

### FACTORY BUILT HOUSING

#### **Introduction**

As illustrated in chapter 3, the massive effort put forward by architects and designers in the past century came short of establishing a foolproof mass housing solution that utilizes the principles of industrialized mass production for many varying reasons. However, it could not be said that the housing industry was not at all influenced by industrialization as did the building industry in general through the mass production of building components such as doors, windows, roof trusses, pre-cast stairs, slabs and wall sections, in addition to tiling, bricks, blocks, and lumber to name a few. These prefabricated components arrive on site to be assembled into configurations set by architects or builders to form site built structures.

Another manifestation of industrialization's impact on the building industry in general and on the housing industry in particular is the emergence of factory built housing structures. This chapter serves as a concise overview of the historical background of these structures, characteristics of their residents, characteristics of the factory built housing industry as well as the types of factory built structures and their manufacturing process in addition to some of the major problems associated with these structures.

#### **Historical Background**

The genesis of mobile homes has been traced to pre-permanent settlement times and to homes of nomadic tribes such as the tents, tepees and caravans. The Vikings'

army ships - which served as battle vessels at sea, and were turned upside down to protect the invaders once ashore- as well as the Conestoga wagon and the railway cabins, have in some way or another been considered early predecessors of the mobile home. Yet, today's manufactured homes are the direct result of a series of events and circumstances that span over the past one and a half century. While these events were triggered by technological developments, Political and economical circumstances were the driving force that shaped the identity of today's structures.

#### The Automobile and the Recreational Vehicle

The invention of the "Horseless carriage" in the 1880's was the basis from which the recreation trailer evolved. Henry Ford's Model T that was introduced in 1908 along with the invention of the assembly line transformed the vehicle from a luxury item to a commodity owned by every family especially after prices dropped from around \$850 in 1909 to about \$360 in 1916<sup>1</sup>. Impressed by the mobility that the automobile offered to access what used to be out-of-reach areas in America, people started attaching compartments to their vehicles, which were used for camping and recreation purposes.

#### From Recreational Vehicles to Temporary Housing

Fascination with the freedom and mobility that the new trailers provided was irresistible and more and more people were attracted to it. In addition to the freedom of mobility, the trailer provided another kind of freedom. For it being considered personal property rather than real estate, meant that it did not incur property taxation, as did conventional housing<sup>2</sup>. As demand increased, manufacturers rushed to supply the market with new enhanced models of the trailer equipped with different luxuries.

---

<sup>1</sup> Batchelor, Ray. Henry Ford, Mass production, Modernism and Design. Manchester University Press, Manchester and New York, 1994. P.22.

<sup>2</sup> Morris, Earl W., and Margaret E. Woods. Housing Crisis and Response The Place of Mobile Homes in American Life. New York State College of Human Ecology at Cornell University, 1971. P.11.

Furthermore, during the years that followed the 1929 depression, the trailer was more than a vacation shelter. The circumstances that prevailed in that period transformed it into a very convenient temporary residence for the American family that was constantly on the move searching for employment or for workers whose occupations demanded *frequent travel*<sup>3</sup>. Moreover, with the start of the Second World War, there was huge demand for housing for the army and military personnel overseas. By 1943 there were 200,000 mobile homes in America, 60% of this total were in military areas<sup>4</sup>. This was another factor that contributed to alter the perception of the trailer from a recreational vehicle to a housing unit.

As demand increased, the industry thrived over this short period and the number of manufacturers soured from about a dozen in 1929 to over 300 in 1935 and over 700 in 1937. Most of these manufacturers however were small in scale, and relied upon manual labor for production rather than automation<sup>5</sup>.

During this period, between 1930's and early 1940's, manufacturers concentrated on satisfying the massive demand for trailer units. In the absence of strict standards and regulations, quality was compromised in favor of higher production rates and economy of materials. Therefore when the war ended in 1943, several manufactures saw it as the end of the boost in the trailer industry which they had taken advantage of for a little more than a decade. As a result, the number of trailer manufacturers dropped from about 105 to 50 as many decided to close their factories and abandon the business<sup>6</sup>.

---

<sup>3</sup> Davidson, Harold A.. Housing Demand: Mobile, Modular, or Conventional? Litton Educational Publishing Inc., 1973. P.9.

<sup>4</sup> Ibid, P.10.

<sup>5</sup> Morris, Woods, "Housing Crisis and Response The Place of Mobile Homes in American Life", P.11.

<sup>6</sup> Davidson, "Housing Demand: Mobile, Modular, or Conventional?" , P.11.

## From Temporary Housing to Permanent Mobile Homes

Contrary to the manufacturers' expectations, demand for trailers for housing purposes increased and reached record heights. Anxious war veterans returned to the States, eager to settle down with their families in homes of their own, but were confronted by a severe shortage of housing units in the market. The rising costs of conventional housing units made them turn, once more, to the trailer as a solution to their housing needs, yet this time it was to be their permanent rather than temporary residence and it was named the mobile home.

Tempted to put their hands on one last piece of the profit pie, many manufacturers who had closed their factories in the early 1940's reopened, and between 1945 and 1951 their number doubled. Business flourished once again, Americans were acquiring mobile homes and competition in the industry was fierce, leading many small businesses out of the race in the 1960's. The mobile home industry, at that time was also faced by a dilemma. Should it continue to produce recreational trailers, or should it dedicate its assembly lines to the production of mobile homes? Eventually, in 1955, the production of RVs and Mobile homes each evolved as a separate industry<sup>7</sup> as manufacturers modified their factory lines to accommodate the production of what they considered the most profitable product for the market they served.

To appeal to new consumers with new housing needs, several changes were introduced to the mobile home. Most notable of which is the dramatic increase in size. As width increased from 8ft in 1955 to 14ft in 1969 and as "expandables", double, and triple widths appeared in the 1970's, the mobile home grew too large to maintain its *mobility*<sup>8</sup>. By 1973, 60% of mobile homes remained at their original site<sup>9</sup>.

---

<sup>7</sup> Bair, Frederick H., Jr., Mobile Homes and the General Housing Supply, Past, Present and Outlook. Mobile Homes Manufacturing Association, 1970.

<sup>8</sup> Sullivan, "Industrialization in the building Industry", p.113

## Codes and legislations

Regardless of the industry's expansion in the 1950's and 1960's, it was faced by a number of major problems. One of which was its association with the low quality, substandard unregulated structures that were built at haste to satisfy demand of the post WWII period and the images of its residents as ill, old, poor and deprived individuals that clung to it while manufacturers struggled to present their products more favorably.

A major obstacle that played a vital role in reshaping the identity of the mobile home in the following two decades was the considerable variations and discrepancies in local building codes across the different regions in the States. While the industry relied on its ability to distribute units to a large market, these differences necessitated that units be modified in order to be brought up to the local building code of their final destination. This inevitably slowed production, increased labor and raised the prices of the final products<sup>10</sup>. Consequently, in the 1950's, Californian manufacturers worked with the Mobile Home Manufactures Association in an effort to establish a unified building standard for mobile homes all across the United States. As a result, the ANSI-A-119.1 came to existence in the 1960's, a code set by the American National Standard Institute (ANSI) to which 45 states were bound by the 1970's<sup>11</sup>.

Federal realization of the need for a separate building code specific to mobile homes followed in the mid 1970's as the congress issued the National Mobile Home Construction and Safety Standards Act in 1974. This act put upon the Secretary of the department of Housing and Urban Development the responsibility of establishing an appropriate mobile home construction and safety standard, which was to be known as

---

<sup>9</sup> Davidson, "Housing Demand: Mobile, Modular, or Conventional?" p.14.

<sup>10</sup> Sullivan, "Industrialization in the building Industry" p. 100.

<sup>11</sup> Morris, Woods. "Housing Crisis and Response The Place of Mobile Homes in American Life" .p.11.

the HUD code administrated by the Department of Housing and Urban Development with the collaboration of third party inspection agencies for its enforcement<sup>12</sup>.

The separation from the trailer industry, the decrease in mobility and these legislative developments were finally reflected in the 1980's by a change in *nomenclature*<sup>13</sup>. The term mobile home was officially replaced by manufactured home; a modification which the industry hoped would be associated with a new identity characterized by a better image due to regulated production.

In the years that followed, close observation and supervision resulted in a number of modifications, studies, and recommendations related to the assembly and performance of the manufactured home surfaced regularly in the form of amendments to the already established HUD code. These amendments touch upon a wide scope of issues some of which are Fire alarms, air conditioning, electrical systems, and transportation.

This sequence of events led to the existence of over 8.9 million manufactured housing units in the United States. As apparent from this brief overview, today's products came about with no specific intent or design strategy to govern its progress and so its development was purely coincidental and shaped by people's needs and prevailing circumstances.

### **Manufactured Housing Residents Today**

According to the 2003 American Housing Survey, of the 8.9 million manufactured houses in the United States, only 6.8 million are occupied as permanent dwellings<sup>14</sup>, as opposed to cabins and vacation lodging; these structures form about

---

<sup>12</sup>Media Center." Manufactured Housing institute. Sep 1<sup>st</sup>, 2005  
[http://www.manufacturedhousing.org/lib/showtemp\\_detail.asp?id=78&cat=5](http://www.manufacturedhousing.org/lib/showtemp_detail.asp?id=78&cat=5)

<sup>13</sup> Burns, Carol. "Regulations." Manufactured Housing : A Double Wide Analysis. Harvard University. Sep, 1<sup>st</sup>, 2005. [http://www.gsd.harvard.edu/studios/s97/burns/man\\_reg.html#hud80](http://www.gsd.harvard.edu/studios/s97/burns/man_reg.html#hud80)



6.5% of the total occupied housing units in the States<sup>15</sup>. Most of the manufactured homes (56.3%) are located in the southern regions of the United States<sup>16</sup> and are home for no more than two residents (59.7%)<sup>17</sup>.

Manufactured homes residents share several characteristics that play a vital role in their choice of their housing structure. According to the 2003 American Housing Survey these units are generally owned by two major age groups, elderly over 65 years and younger householders between 35 and 44 years old comprising 21.7% and 21.5% of the total occupied manufactured housing structures respectively (Fig 4.1). The elderly however form a larger percentage of the residents of these units as 24 % of the occupied manufactured homes house at least one resident of that age group regardless of the unit's ownership. About 9% of manufactured homes house married couples within that age category while another 9.5% house elderly over 65 in age living alone, of whom 75% are women. On the other hand, most of these households (62%) house no children below 18 years old, although 48% are owned by married-couple families of all ages and 22.4% are owned by married-couple families less than 45 years in age (Fig 4.1 & 4.2).

---

<sup>14</sup> U.S. Census, U.S. Department of Commerce, & U.S. Department of Housing and Urban Development, American Housing Survey 2003, Sep 2004

<sup>15</sup> Ibid

<sup>16</sup> Ibid

<sup>17</sup> Ibid

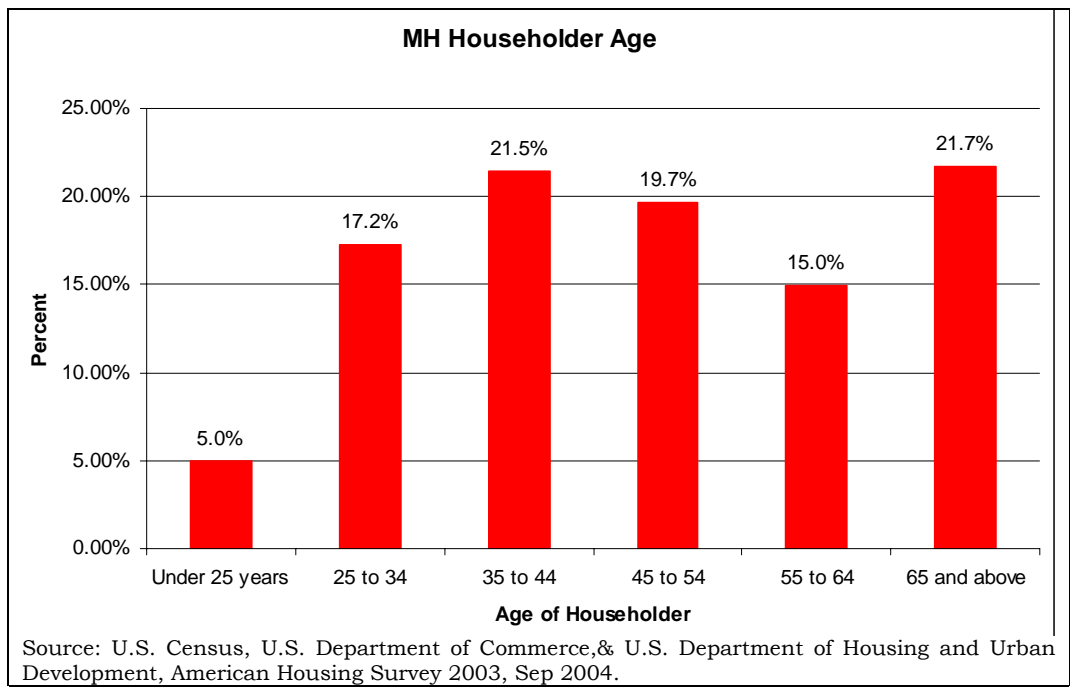

Figure 4.1 Age of MH householders as percentage of total MH householders

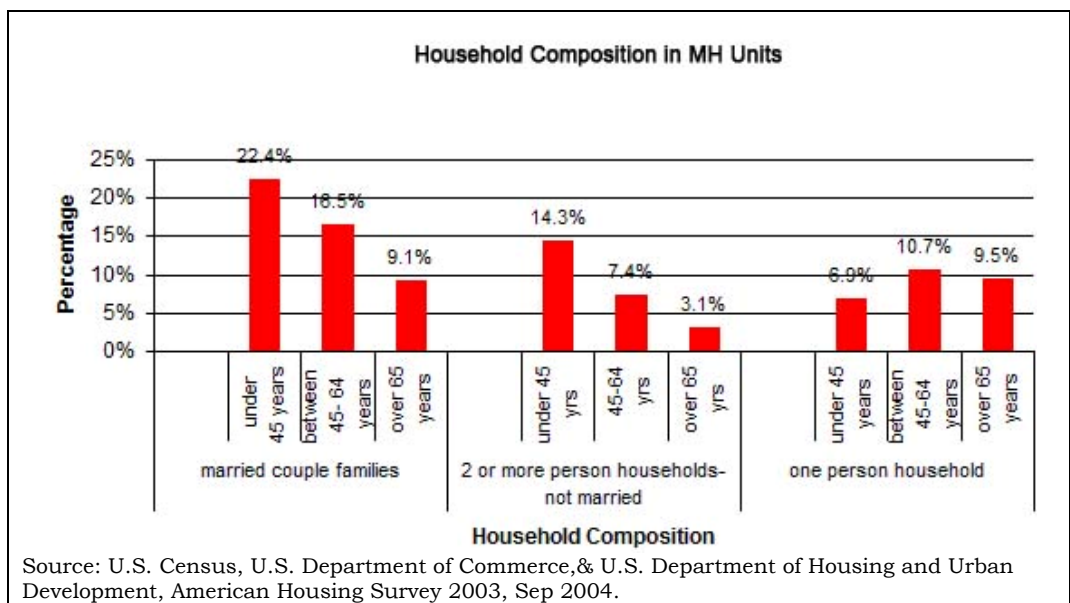

Figure 4.2 Manufactured homes household composition as percentage of total MH households

Regardless of their age group, manufactured home householders share in common a humble educational background, which for over 70% of these households does not exceed a high school diploma (Fig4.3). This is consequently reflected on the household income being less than \$30,000 for over 50% of the occupied units (Fig 4.4) and is further intensified for 35% of the households that have no collateral to rely upon.

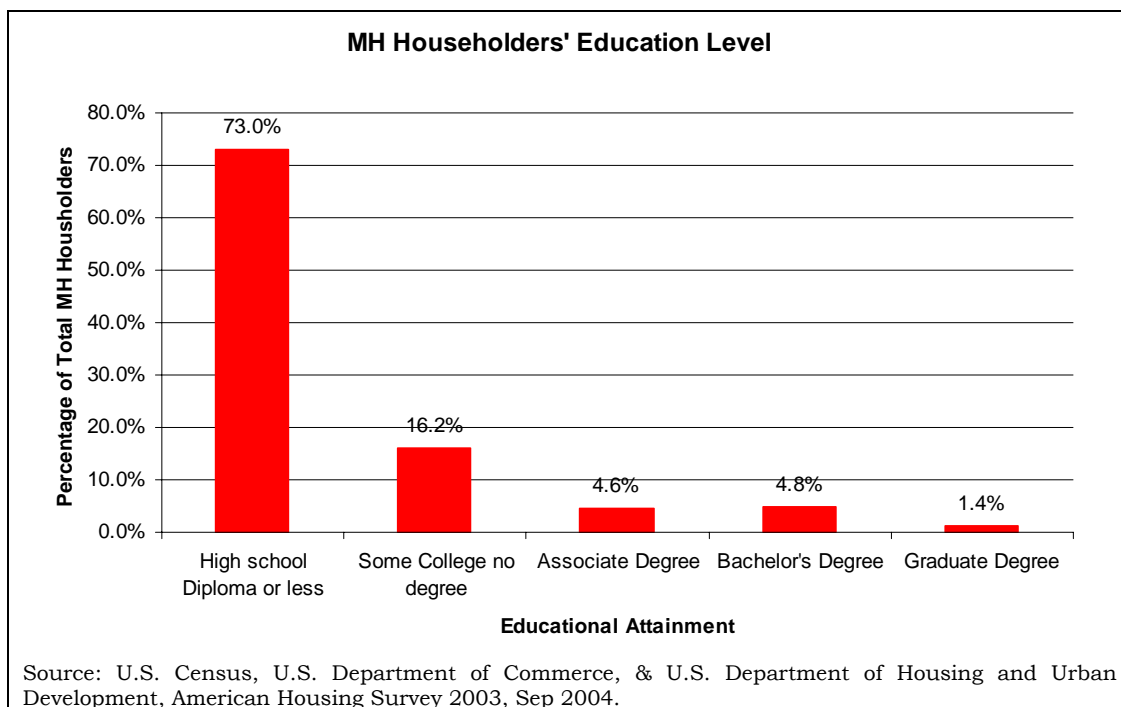

Figure 4.3 Educational attainment of MH householders as percentage of total MH householders

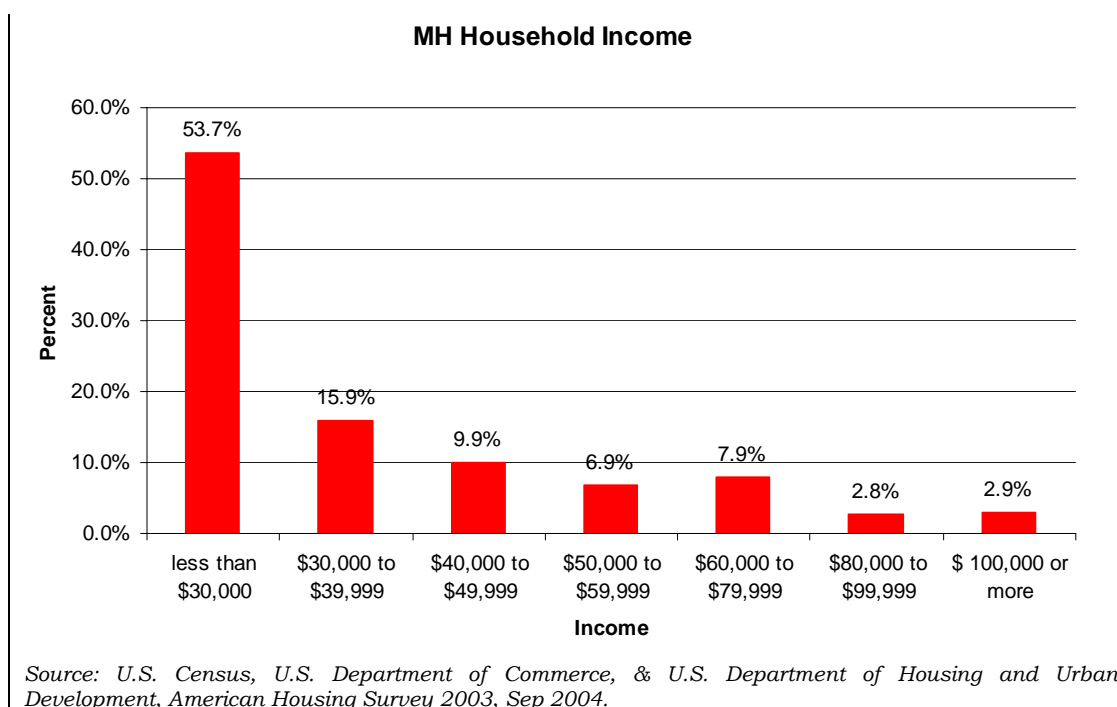

Figure 4.4 Income of MH households as percentage of total MH households

Two images of the typical manufactured house resident emerge. The first is of either the retired elderly couple or individual elderly citizen, who opts to spend his/her retirement in a smaller house somewhere in the south by thus cutting down housing expenses due to reduction in the size of the housing unit. In addition to the financial factor, this couple or individual may favor the lifestyle of manufactured homes retirement communities and seek mild weather conditions in the warmer southern regions. The second typical manufactured home owner is most probably a young newly married couple. This couple, realizing that they would not be able to afford the rising costs of conventional housing at an early point in their live, and preferring the privacy of a detached house to living with their parents or living in apartments, chooses the manufactured house to be their first residence. In either case, whether elderly or young couples, these typical residents view the financial aspect as a governing factor when it

comes to their choice of manufactured housing units as a dwelling over the other available alternatives (Fig4.5).

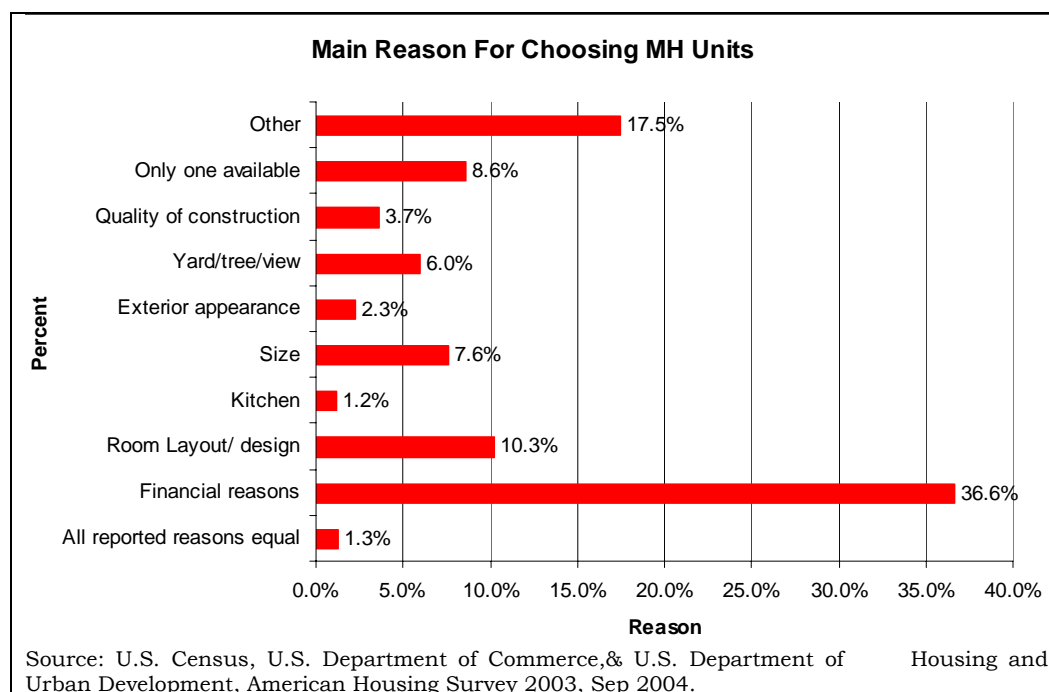

Figure 4.5 Main reason for MH householders' choice of MH as a residence

### The Manufactured Housing Industry

Although Modular, Panelized, and Pre-cut homes, like manufactured homes, are types of factory built housing, manufactured homes dominate this industry in terms of market share. Shipments of Modular housing units in 2004 did not exceed 32.1% of manufactured home shipments while all the other types of factory built dwellings including panelized and pre-cut barely comprised 27.5% of manufactured home shipments in that same year (Fig 4.6). This dominance is probably owed to the lower price of the manufactured home, as it requires less site work during installation when compared to the other factory built housing structures.

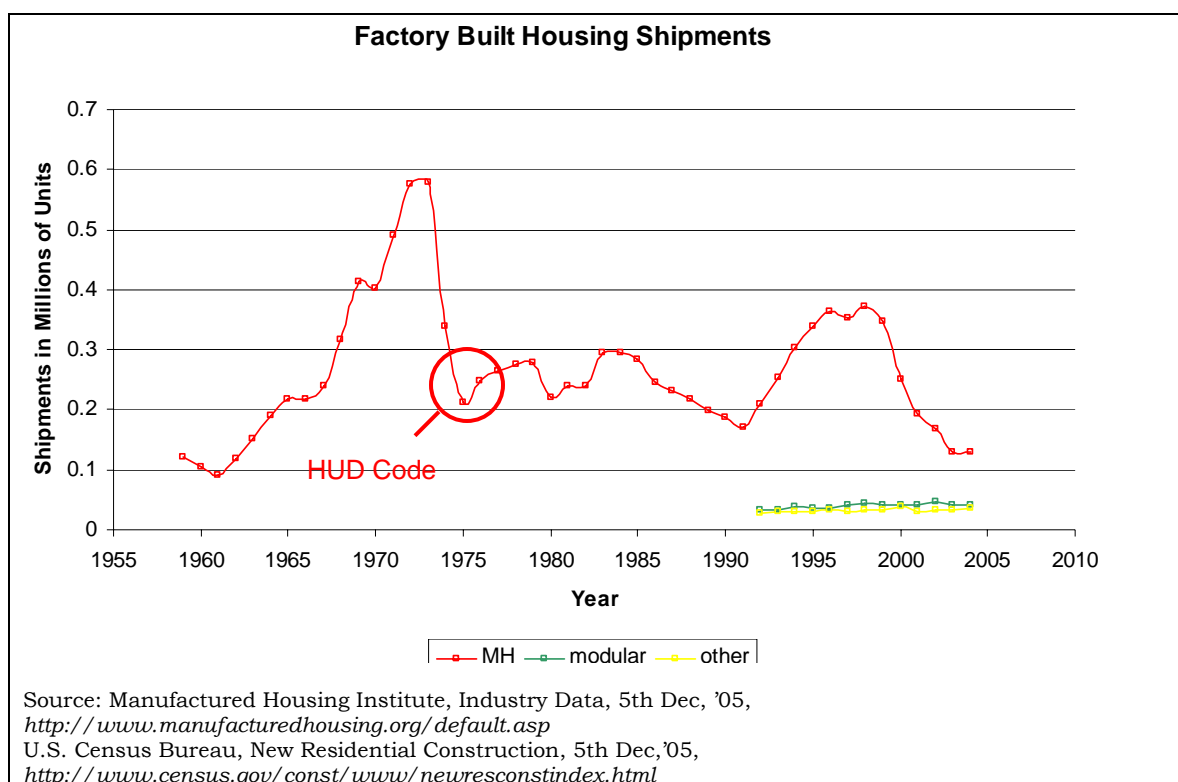

Figure 4.6 MH, modular, panelized and precut homes shipments (1959-2004)

When compared to conventional single-family site built housing, manufactured home shipments formed about 9% of the completed site built houses in 2004 (Fig 4.7) and manufactured home placements were around 12% of the conventional single family homes sold that year( Fig 4.8). These percentages reflect a record low in shipments and placements of manufactured houses since the HUD code came into effect in 1976. This decrease in percentage results from a decrease in the number of manufactured homes shipped and placed couple with the increase in the number of conventional homes completed and sold that took place in the past decade.

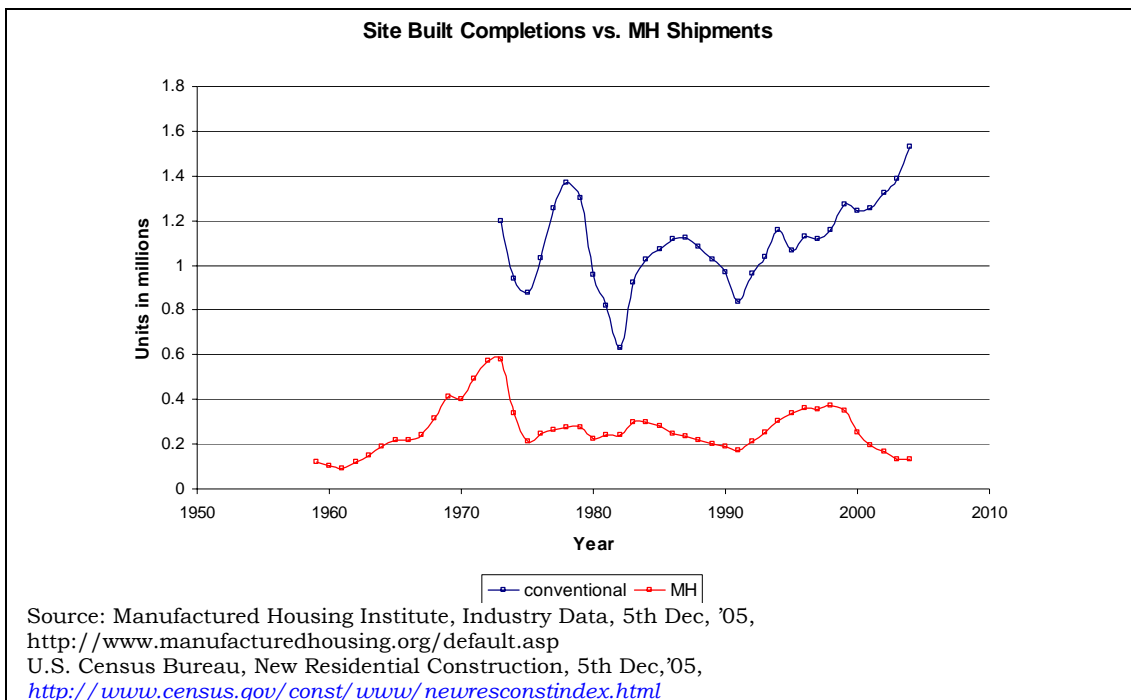

Figure 4.7 Comparison between MH shipments and Conventional housing completions (1959-2004)

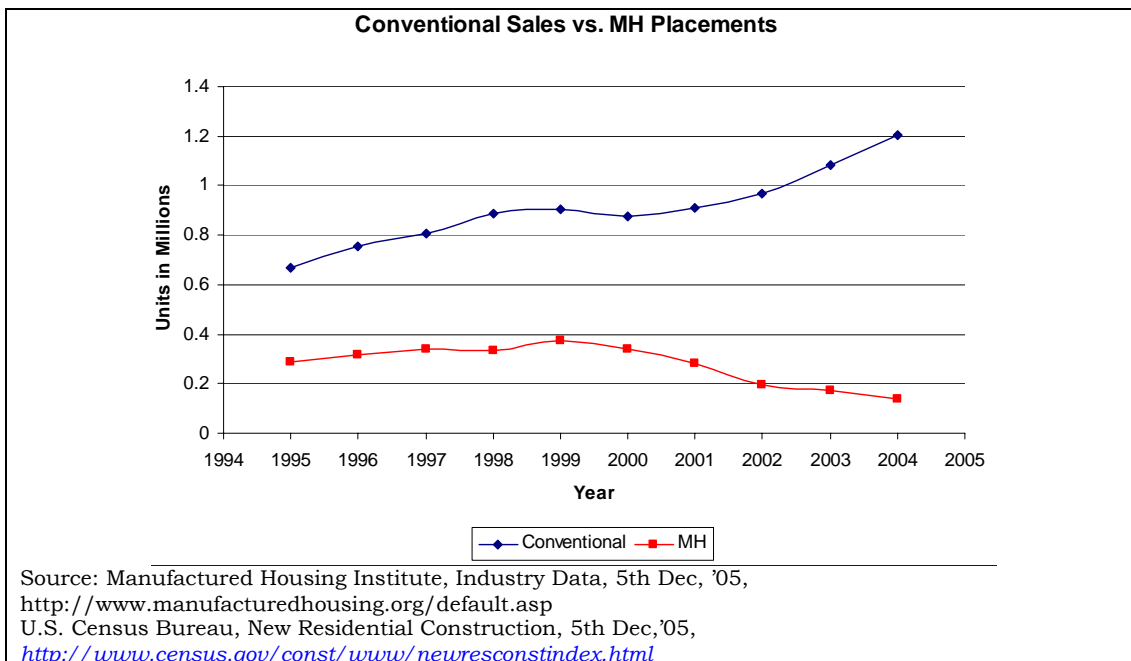

Figure 4.8 Comparison between MH placements and conventional housing sales (1959-2004)

A similar pattern is evident when comparing the manufactured home and recreational vehicle shipments. Although the two industries once formed a single thriving business in the 1930's and 1940's, today the manufactured home shipments comprise only about 35% of the total RV shipments (Fig 4.9).

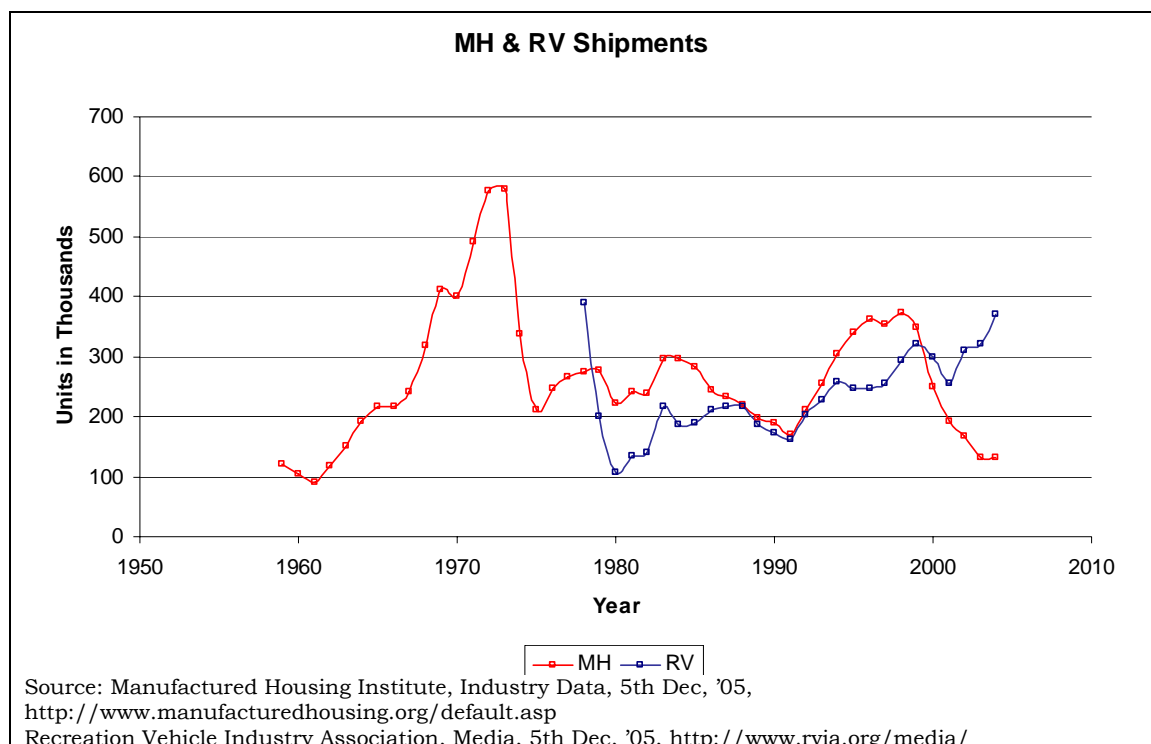

Figure 4.9 Comparison between MH housing shipments and RV shipments (1959-2004)

This severe decline in shipments reveals the financial difficulties confronting the manufactured home industry. The industry which in 2003 comprised of 62 manufacturers running 206 production facilities<sup>18</sup> is dominated by its top five manufacturers who produce over 50% of the total shipped units (Fig 4.10). These manufacturers sustained huge losses in revenue that -in some cases- approached and

<sup>18</sup> Manufactured Housing Institute, Industry Data, 5th Dec, '05, <http://www.manufacturedhousing.org/default.asp>



exceeded 50% in 2003 (Fig 4.11). While corporations such as Champion Enterprises and Fleetwood Enterprises were able to absorb these losses due to their diversified product base, as they market recreational vehicles, and modular as well as manufactured homes, other manufacturers exclusively producing manufactured housing units found it necessary to cut down on production costs to withstand these losses and avoid being driven out of business.

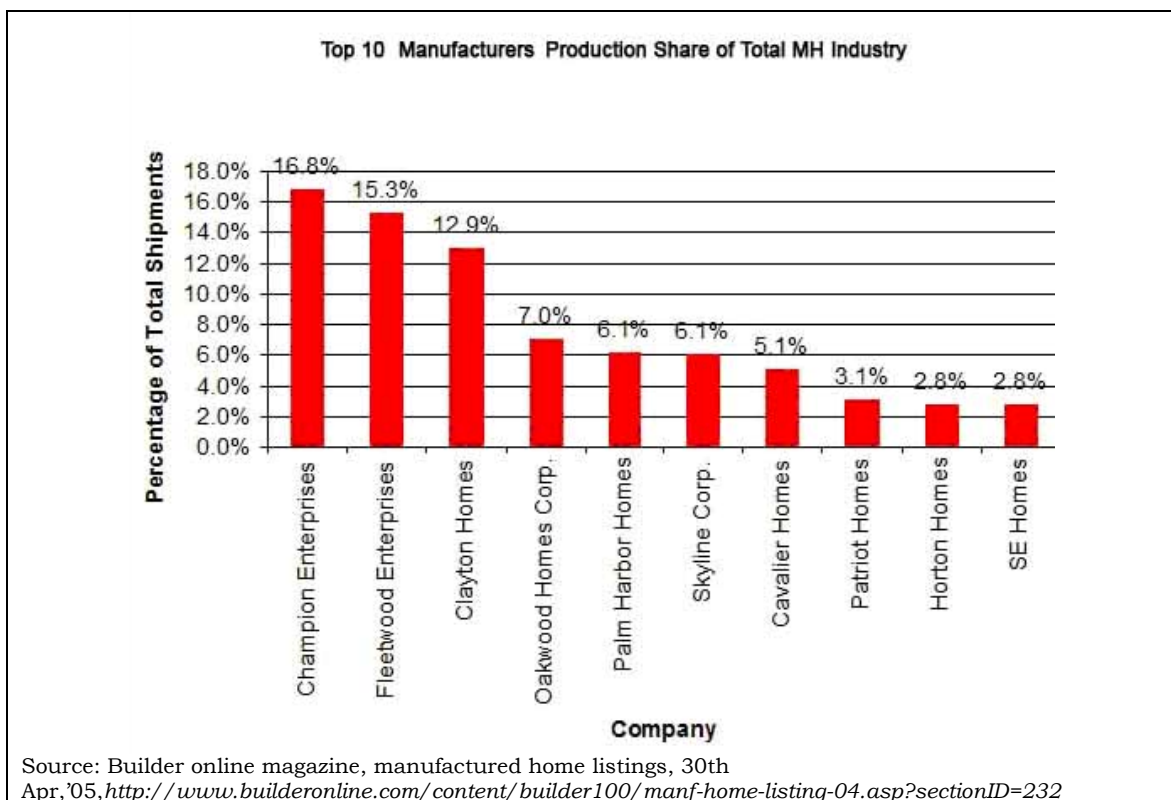

Figure 4.10 Percentage of MH shipments produced by top 10 manufacturers in the industry as percentage of total MH shipments in 2003

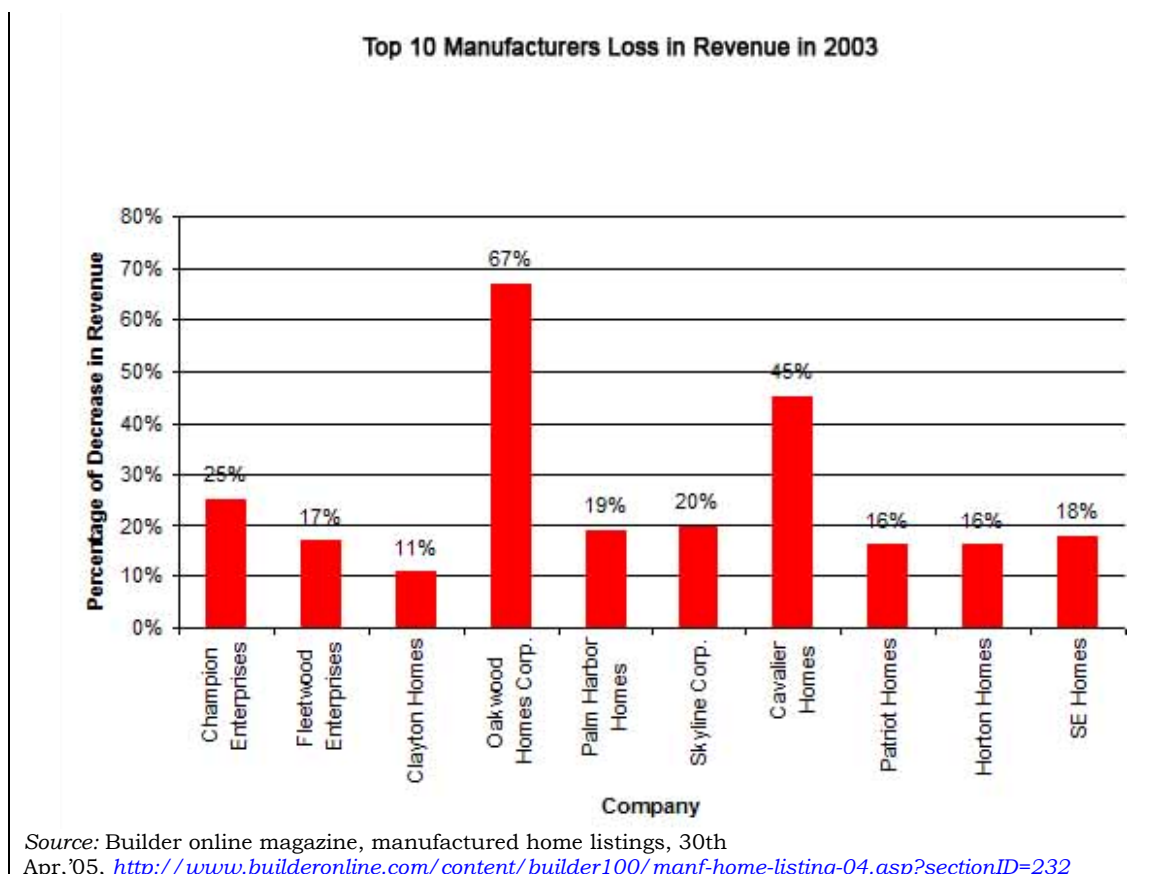

Figure 4.11 Losses in revenue endured by top 10 MH manufacturers in 2003 as percentage of 2002 revenues

While this may indicate that manufactured housing is gradually losing its appeal in the single family housing market, it could not be overlooked that the manufactured house is emerging as an emergency housing solution following natural disasters. This has helped boost the industry in the past couple of years and slightly subdue the consequences of its past-incurred losses.

### **The Product**

The manufactured home is produced in two main varieties. The smaller version, usually not exceeding 15' in width and averaging between 60' and 80' in length, is commonly known as the "single section" or "single wide". While the larger version

known as the “double section” or the “double wide” has the same length of the single wide but double its width since it is basically a combination of two single wide units. The average price of a manufactured home was \$58,100 in 2004 with prices of single sections averaging at \$32,800 and double sections at \$63,300<sup>19</sup>. Regardless of their higher price, double sections have a considerably higher market share than that of single sections and formed 74% of the total manufactured home shipments in 2004 (Fig4.12). This is probably due to the marginal difference in value per square foot between the two varieties weighed against the amenities provided exclusively in the double section.

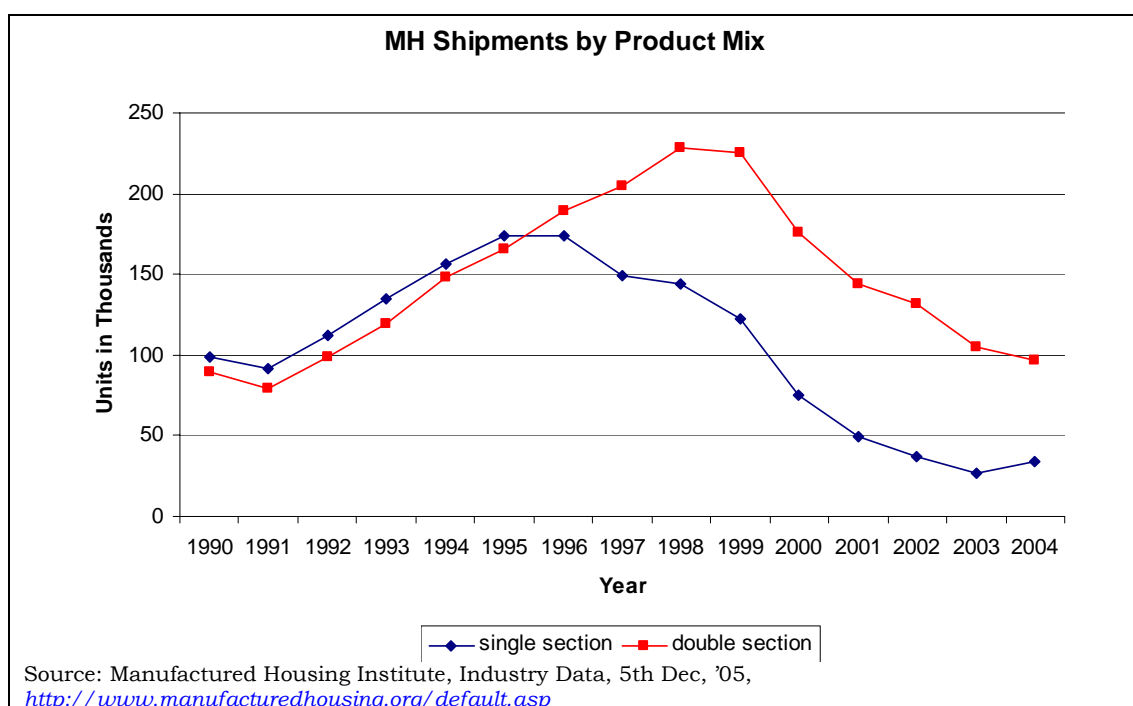

Figure 4.12 Comparison of single section and multi section manufactured home shipments (1990-2004)

<sup>19</sup> Ibid

The financial advantage of manufactured homes is further clarified upon the comparison of the price per square footage. While manufactured housing averaged at \$35.75 per square foot, conventional housing was recorded at \$86.75, more than double that of manufactured homes in 2004 (Fig 4.13).

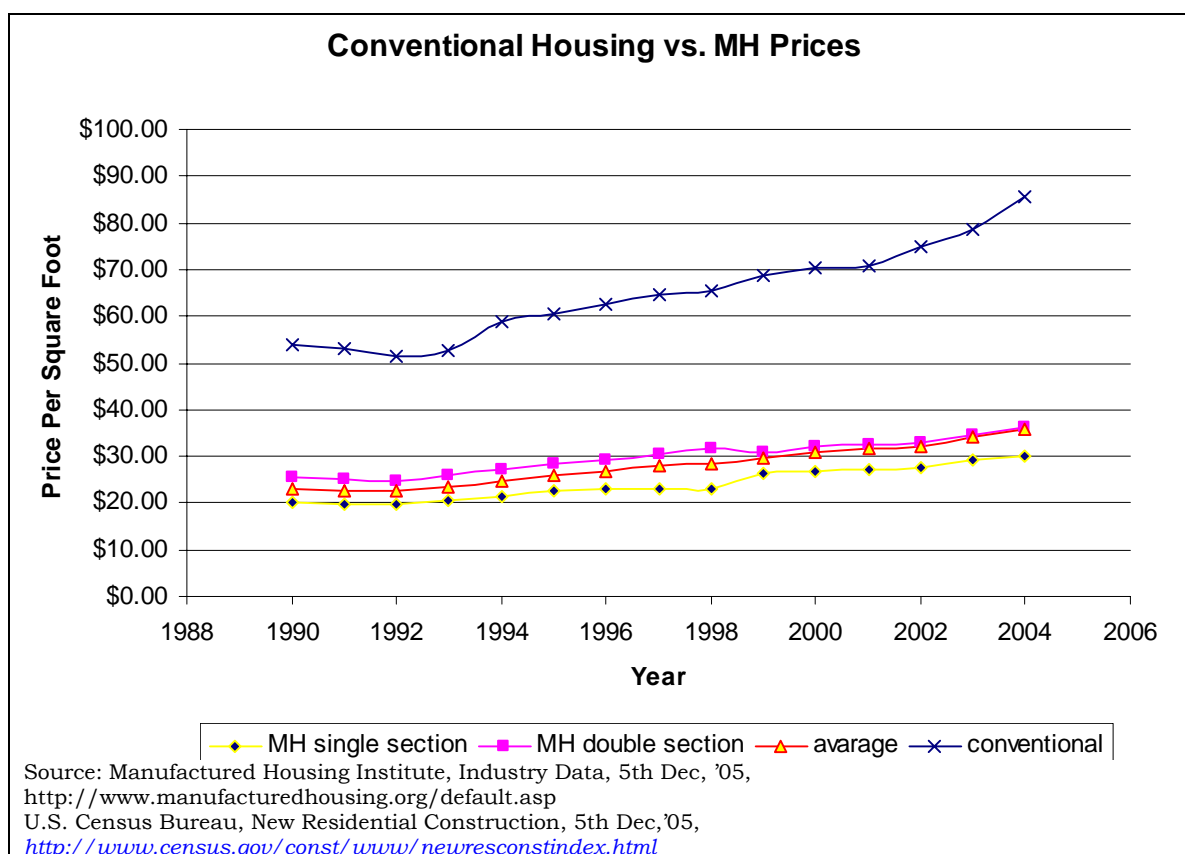

Figure 4.13 Comparison of prices per square footage for single section, Double section, average MH, and conventional housing (1990-2004)

Ironically, though having the advantage of the factory setting, the production of the manufactured home follows a process identical to that of construction of stick built homes, using the same techniques and equipment and depending chiefly on manual labor rather than automation. A survey conducted across several manufactured housing producers to look into the level of computerization involved in the process (Barrow & Pan, 2001)(Appendix A), revealed that use of technology, even at its most

modest levels, was limited to a very small percentage, and even then it was restricted to administrative and managerial tasks not affecting production. Following the survey, a case study of “Cavalier Homes” manufacturing facility in Alabama one of the producers using a relatively higher-level technology in production was carried out to give further insight on the production process (Appendix B). As observed from the images and information obtained from this case study, this process was found to be based on four consecutive operations, namely, the floor assembly, wall installation, roof construction, and finishing and testing.

The assembly of the floor of the single section unit starts with the preparation of the chassis and the axles and tires on which the unit will be pushed and moved across the factory passing through each of the remaining stations until the end of the line where the unit is finally completed. Following the chassis preparation, ducting, drainage, and hot and cold water supply pipes are laid on the bottom plate, the wood joists are laid over the chassis and wood decking covers what will form the base of the unit. The single section unit then proceeds to the next station where vinyl tiling is placed at the kitchen and bathroom areas. A double section on the other hand is composed of two such units, one of which houses the kitchen and all bathrooms and toilets, the other having no wet areas within it. Vinyl tiling is laid on the former section, while the latter skips this stage directly proceeding to the wall installation phase (Fig4.14).

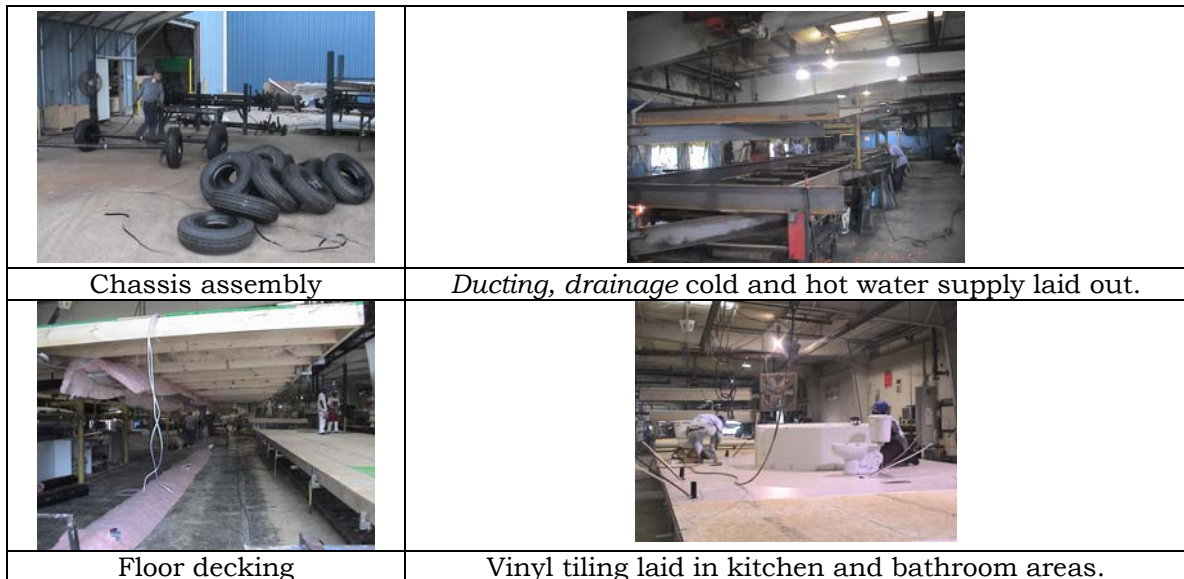

Figure 4.14 Floor assembly phase of MH production

Before installation of the walls, kitchen and bathroom fixtures are placed. Interior walls, which have been preassembled at a feeder station, are then fixed to the floor base and electrical wiring and switches are installed. Once all the interior walls are fixed in place, installation of exterior walls starts following the same method. The two sections of the doublewide unit are joined together temporarily when fixing the exterior walls to ensure that the marriage walls, where the joint between the two units occur, are perfectly aligned before the roof installation (Fig4.15).



Figure 4.15 Wall installation phase of MH production

The two section of the doublewide unit remain joined together at this stage as the roof is being constructed on top of the unit. Meanwhile, the interior finishes are completed, electrical installations of the unit are being done, and appliances and furniture installed. In the final phase, the two halves of the doublewide unit come apart again while exterior finishes such as painting of the exterior is concluded and doors and windows are placed. Following this, the units are tested and inspected before they leave the assembly line (Fig 4.16).

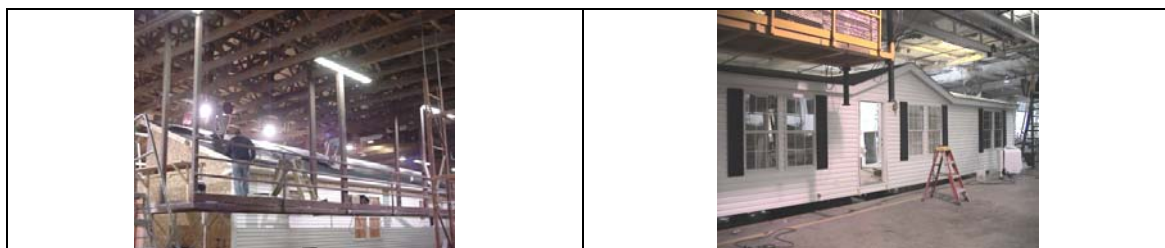

Figure 4.16 Roof construction and finishing and testing phases of MH production

As observed, the similarity with the conventional housing construction does not end with the method of assembly of the units but extends to the type of material used for construction. Apart from the chassis, the entire construction of the manufactured home unit uses wood as a primary material, intensively using members with smaller thickness than those used for conventional housing (Fig 4.17-4.19), both to economize in material cost and to reduce the weight of the unit – a factor that influences ease of transportation and installation of the unit.

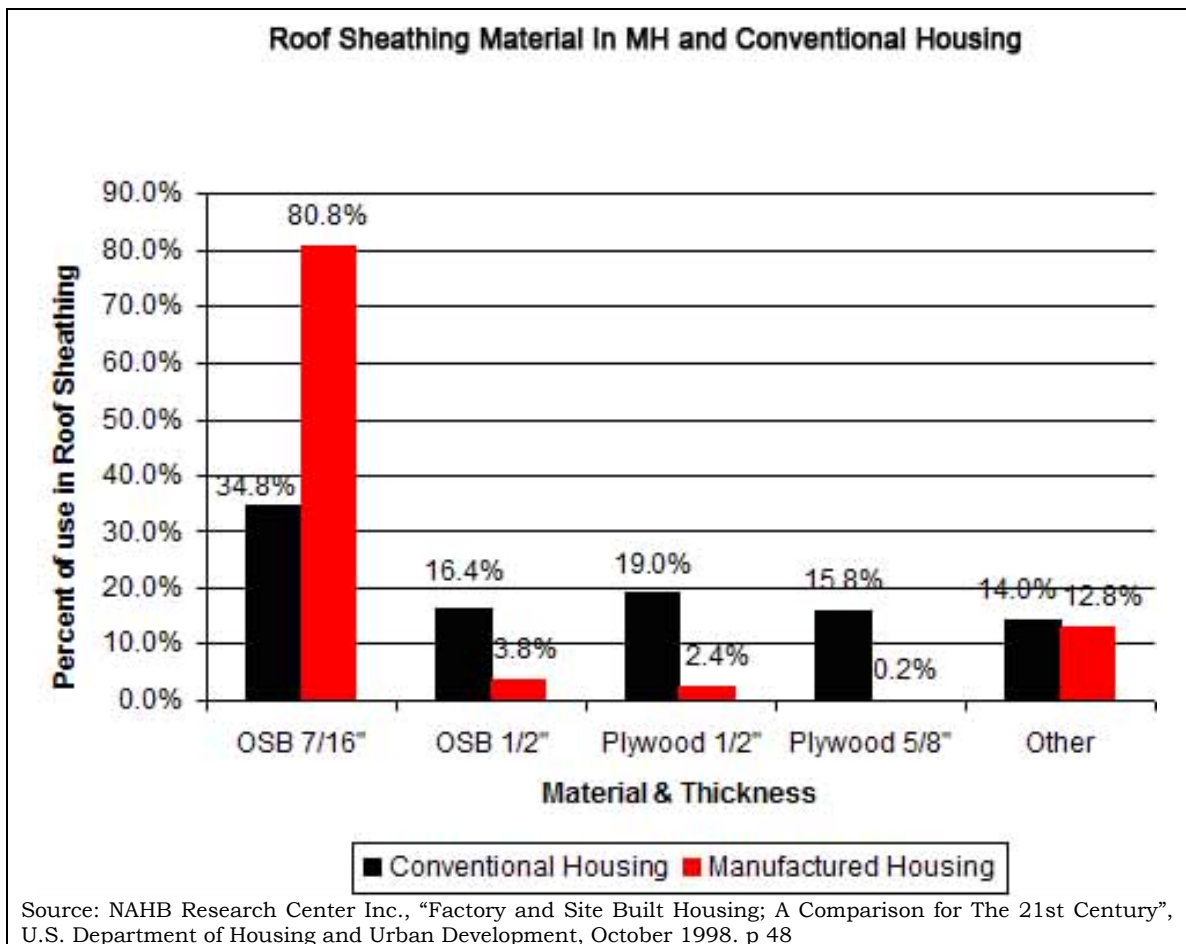

Figure 4.17 Roof sheathing material used in conventional and MH housing as percentage of total material used in construction



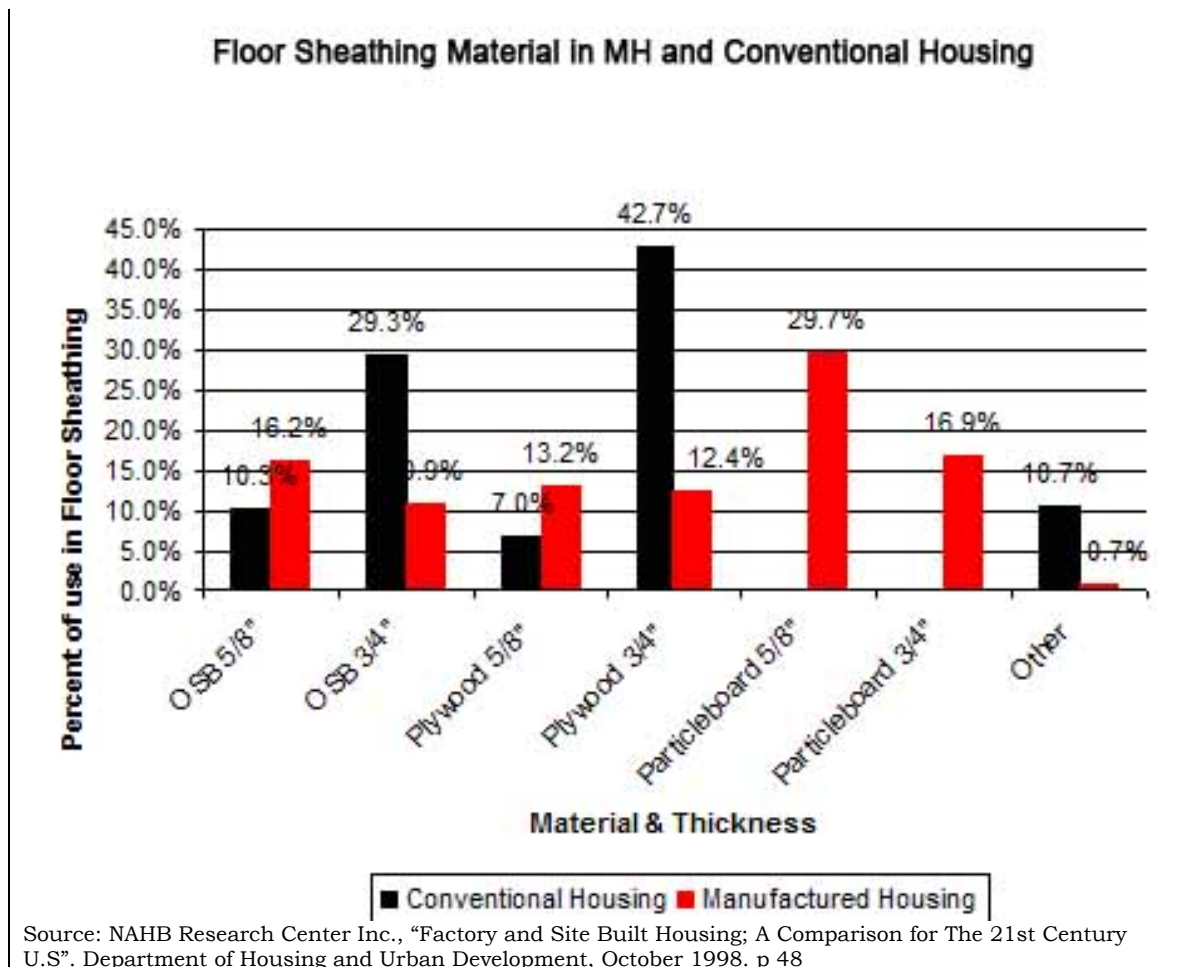

Figure 4.18 Floor sheathing Material used in conventional and MH housing as percentage of total material used in construction

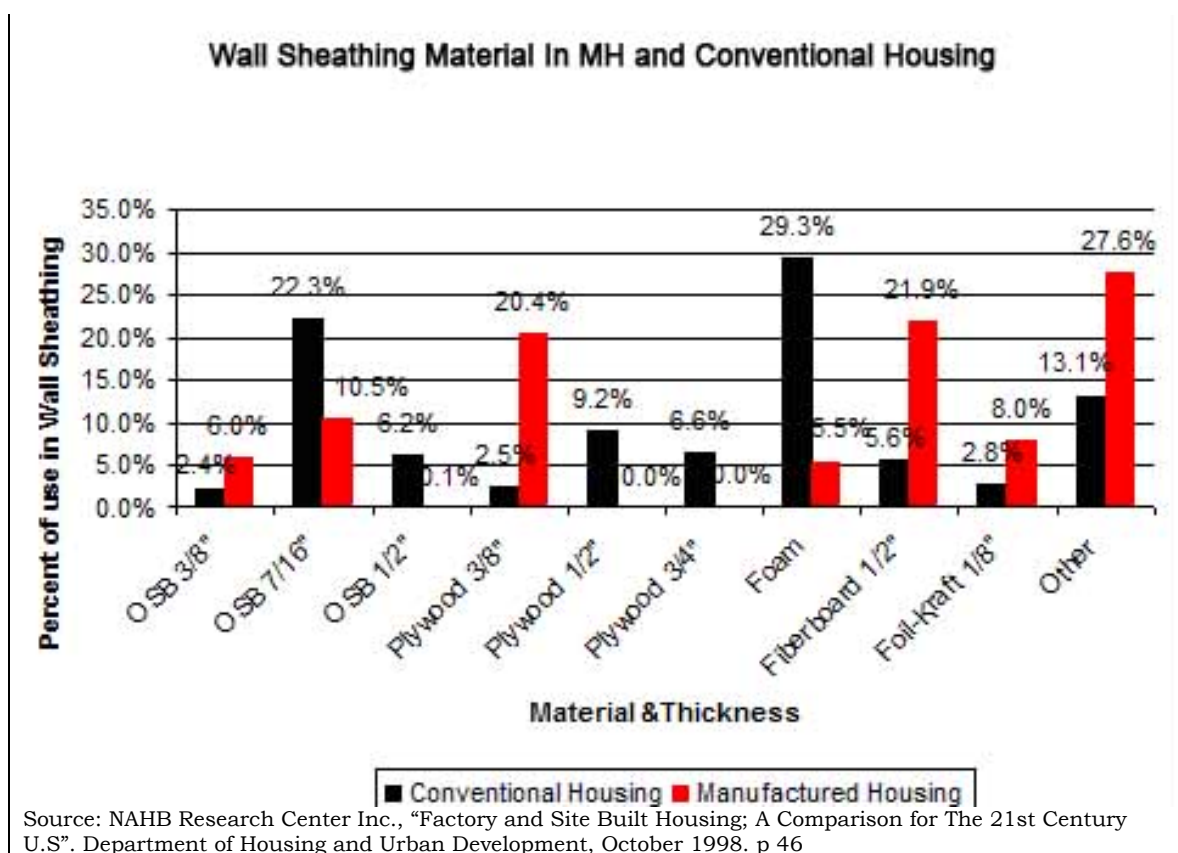

Figure 4.19 Wall Sheathing Material used in conventional and MH housing as percentage of total material used in construction

### Problems

To many, the low cost of the manufactured home units in comparison to conventional housing may be the solution to their housing needs in light of the lack of financial means. Yet, this solution suffers from several shortcomings, which on the long run entail considerable resources in many cases extending beyond those that are financial in nature. These shortcomings could be summarized in seven major problems that relate to the units' excessive flammability, vulnerability to severe weather, low indoor air quality, low durability, high cost of financing and insurance, difficulty of transportation, and biased zoning laws and regulations against placement of these units, and their general form and aesthetic that generates negative perception.

## Flammability

According to the U.S. fire administration National Fire Data Center, residential fires in the states dominate the fire fatality, injury and loss statistics requiring serious concern. Within this category, manufactured housing stand out as the structure claiming the most lives per thousand fires amounting to 271 deaths in 2001<sup>20</sup>, nearly three folds the lives claimed by conventional one and two family housing structures (Fig4.20).

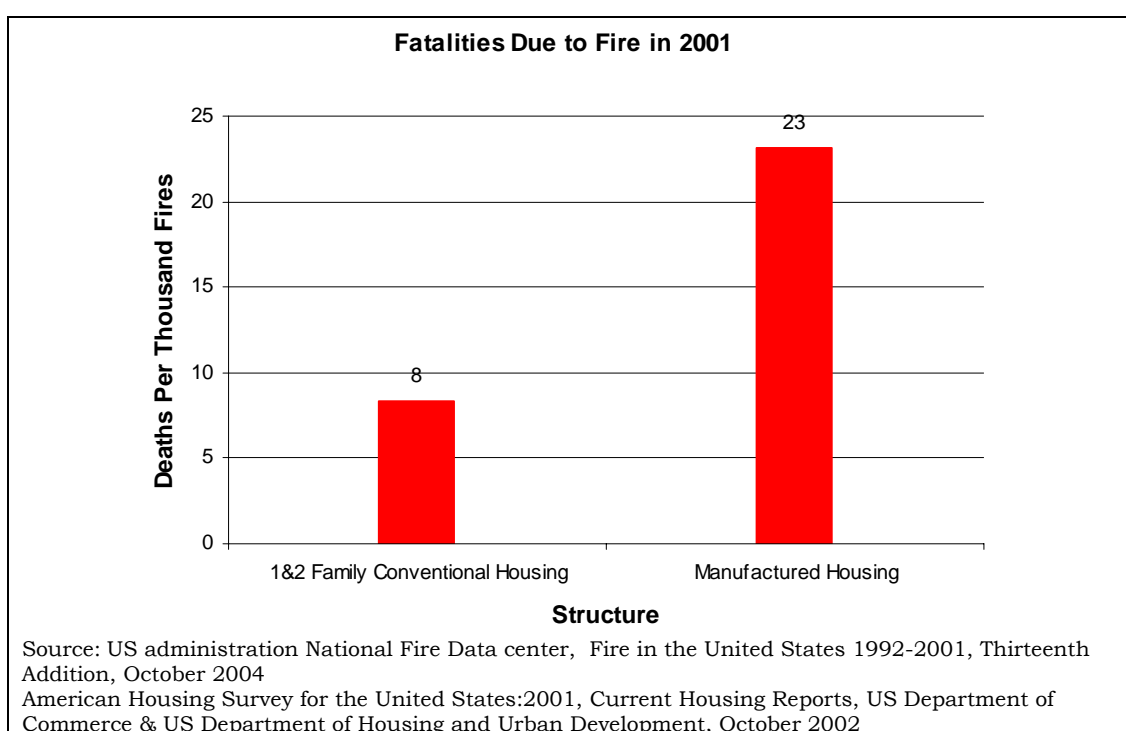

Figure 4.20 Deaths per thousand fires in 1& 2 family conventional housing and manufactured housing

This staggering statistic could be attributed to two causes the first of which is related to the materials used for the construction of the manufactured housing unit. Thin light wood members used as construction material burn up rapidly consuming the

<sup>20</sup> US administration National Fire Data center, Fire in the United States 1992-2001, Thirteenth Addition, October 2004

entire unit. In addition to that the use of large amounts of foam for insulation as well as plastics for furniture and fixtures that are flammable, combustible and off gas toxic chemicals when burning leads to the suffocation of the occupants. Moreover, leading causes for fire deaths in manufactured homes reveal another aspect of the structures deficiency. The main causes for fire deaths in manufactured homes are equipment in the housing units, smoking and electrical distribution at 24.2%, 18.2%, and 15.2% respectively<sup>21</sup>. This suggests that a significant percentage of fire deaths are caused by faulty equipment and electrical wiring that are part of the original construction of these units. The second cause relates to the high percentage of elderly residents who are 65 years and above. This particular age category has the leading overall fire death rate rising to 131.5 deaths per million in 2001, with the distant second leading category being children under 4 years at 22.9 deaths per million persons<sup>22</sup>.

This displays a sad scenario where the elderly who are perhaps the less physically capable of quickly eluding the danger of a rapidly consuming fire, fall victims in highly flammable structures. Although, surprisingly the number of fires in manufactured homes is only about a third and losses per fire are only about two thirds of that in one and two family conventional housing<sup>23</sup>, the high death rate gives this problem merit to be the most serious one posed by manufactured housing. (Fig 4.21) illustrates the causes and effects of the flammability of manufactured homes.

---

<sup>21</sup> Ibid

<sup>22</sup> Ibid

<sup>23</sup> Ibid

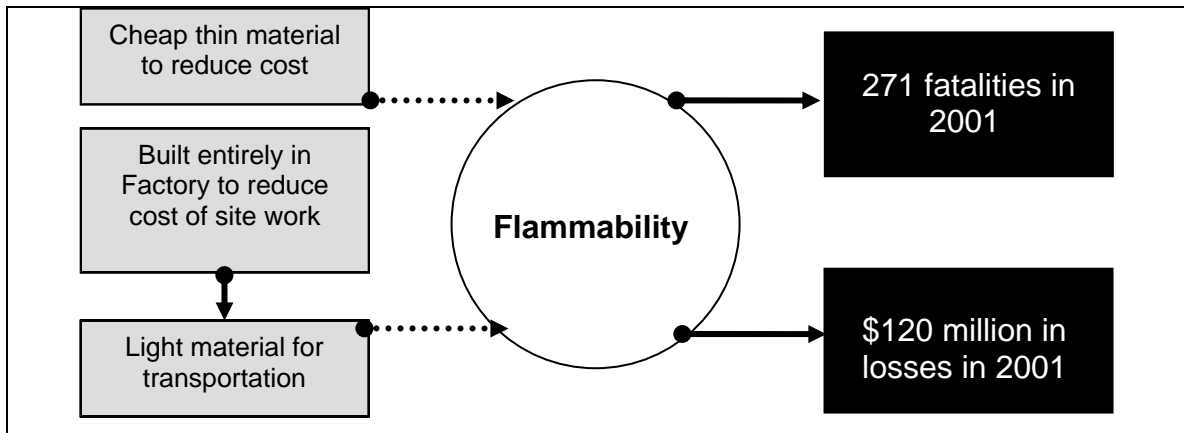

Figure 4.21 Causes and effects of manufactured home units' excessive flammability

#### Vulnerability to Extreme Weather Conditions

Annually, Hurricanes, tornadoes and floods claim hundreds of lives (Fig4.22) and cause billion dollar losses<sup>24</sup>. Although the losses and damage caused by severe weather conditions is not restricted to manufactured homes, these structures are by far the most vulnerable. Damages caused by extreme natural phenomenon could be classified into two categories. Wind generated damage, such as that caused by hurricanes, and tornadoes, and water based damage such as that caused by floods, storm surges accompanying hurricanes, heavy rain storms, and annual river floods.

<sup>24</sup> National Oceanic and Atmospheric Administration, <http://www.nhc.noaa.gov/aboutsshs.shtml> , 29th Dec,'05

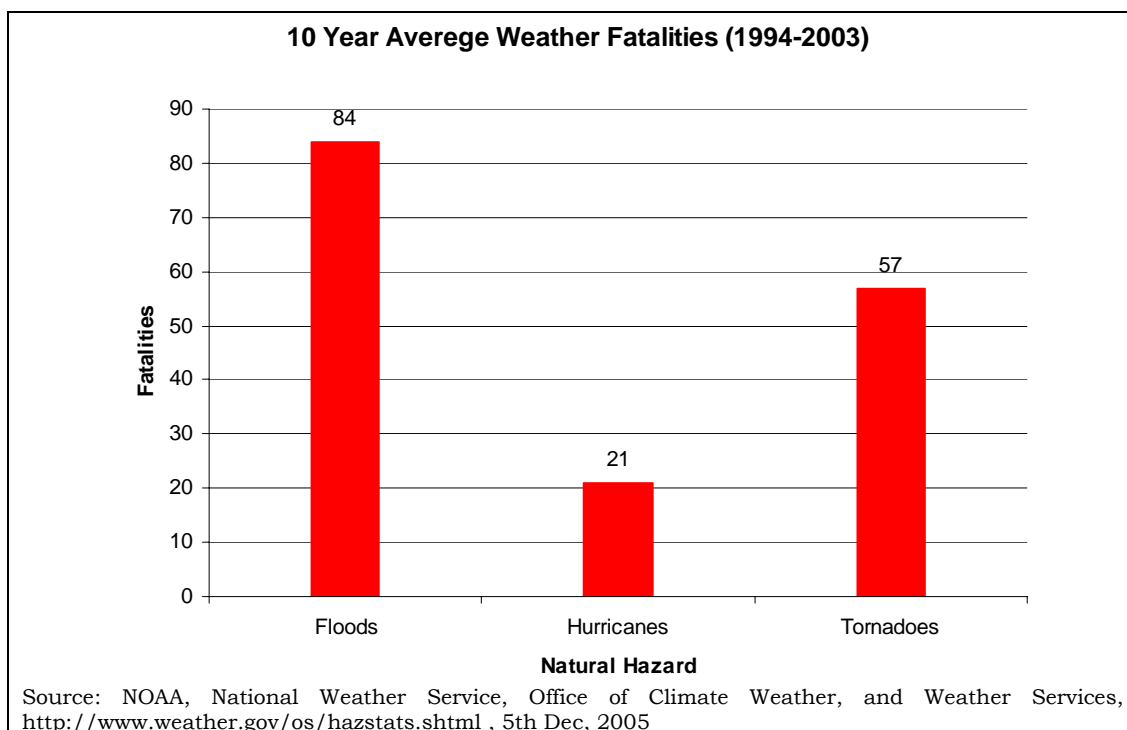

Figure 4.22 Average 10 year (1994-2004) floods, hurricanes, and tornado fatalities

Table 4.1 The Saffir-Simpson Hurricane Scale

Category	Wind Speed (mph)	Storm Surge (ft above normal level)	Damage	
			Conventional Homes	Manufactured Homes
1	74-95	4-5	No real damage to building structure	Unanchored manufactured homes damaged
2	96-110	6-8	Some roofing material, door and window damage of buildings	Considerable damage to manufactured homes
3	111-130	9-12	Some structural damage to small residences.	Manufactured homes are destroyed
4	131-155	13-18	Complete roof structure failure on small residences and extensive damage to doors and windows.	Complete destruction of manufactured homes
5	>155	>18		Complete destruction of mobile homes.
Source: National Oceanic and Atmospheric Administration, "The Saffir - Simpson Hurricane Scale" <a href="http://www.nhc.noaa.gov/aboutsshs.shtml">http://www.nhc.noaa.gov/aboutsshs.shtml</a> , 29th Dec,'05				

Both the Saffir-Simpson Hurricane scale (Table 4.1) and the Fujita tornado scale (Table 4.2) indicate that manufactured homes endure more serious damage than conventional housing especially at relatively low wind speeds. This is not surprising as it could be attributed to factors related to the construction and the installation of these units. The light weight of the manufactured home though an advantage while being transported and installed is a hazard as the unit is easily lifted and moved during strong wind storms. Furthermore the shape of the manufactured home and the elevated

block piers that utilizes strap tie downs to secure the unit in place instead of more solid concrete foundations plays a significant role in maximizing uplift forces that pick up and over turn the unit (Fig 4.23 & 4.24).

Table 4.2 The Fujita Tornado Intensity Scale

Category	Wind Speed	Damage	
		Conventional homes	Manufactured homes
F0	<73	Some damage to chimneys	Some damage to chimneys
F1	73-112	Surface peeled off roofs	Manufactured homes pushed off foundations of overturned
F2	113-157	Roofs torn off frame homes	Manufactured homes demolished
F3	158-206	Roofs and some walls torn off well constructed homes	
F4	207-260	Well constructed houses leveled and structures with weak foundations blown away some distance.	
F5	261-318	Strong frame houses leveled off foundations and swept away	

Source: National Oceanic and Atmospheric Administration, "Fujita Tornado Intensity Scale", <http://www.outlook.noaa.gov/tornadoes/fujita.htm>, 29th Dec, 05



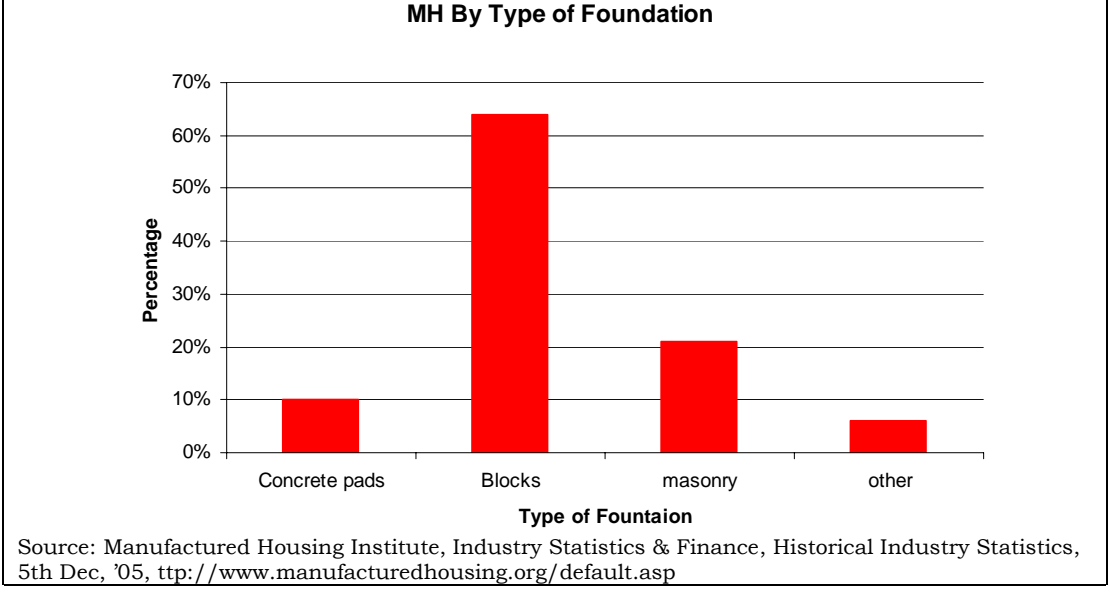

Figure 4.23 MH by percentage of foundation type based on 2001 data

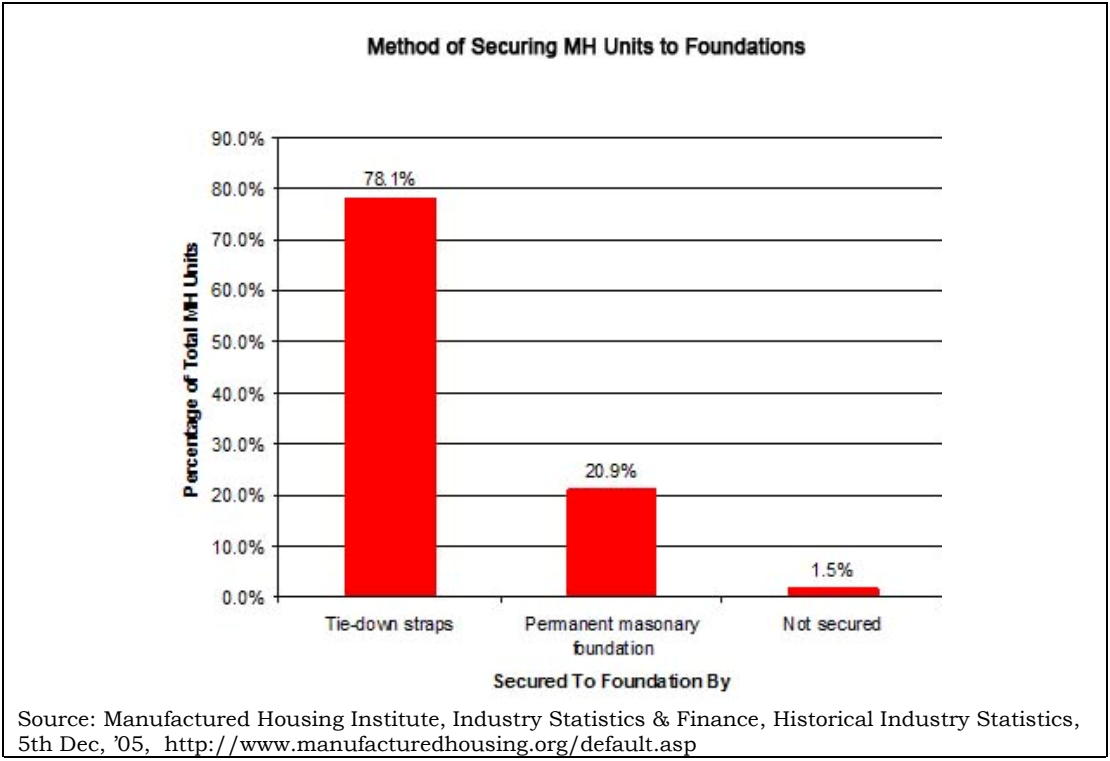

Figure 4.24 MH by method of securing to the foundation based on 2001 data

As the path of hurricanes can be forecast well in advance facilitating evacuation when and if necessary, fatalities due to hurricane winds are minimized. Tornadoes on the other hand, being harder to predict as they form rapidly in a matter of minutes, claim the lives of a higher percentage of people in their homes. In 2005, 34 manufactured home residents died of a total of 39 who perished due to tornadoes<sup>25</sup>. Hurricane winds alone may not cause as much fatalities, however the cost of their damages is considerably greater than the cost of tornado damages as their geographic scope is much larger.

The effect of hurricanes is amplified when strong winds are accompanied by tidal surges causing flooding. Like tornadoes, floods can happen within a short timeframe causing high fatality rates on a yearly basis. Both conventional and manufactured homes are affected by such a disaster, yet its effects on manufactured homes are of greater impact. Being light in weight and poorly anchored in place, as established earlier, they are easily pushed off their foundations drifting with strong waves into ditches and channels. If not moved by water, manufactured homes suffer from leakage through their envelope during heavy rainstorms more often than conventional houses (Fig 4.25).

---

<sup>25</sup> NOAA's National Weather Service, Storm Prediction Center, Tornado Fatalities By Location, <http://www.spc.noaa.gov/climo/torn/locations.html>, 29<sup>th</sup> Dec, '05

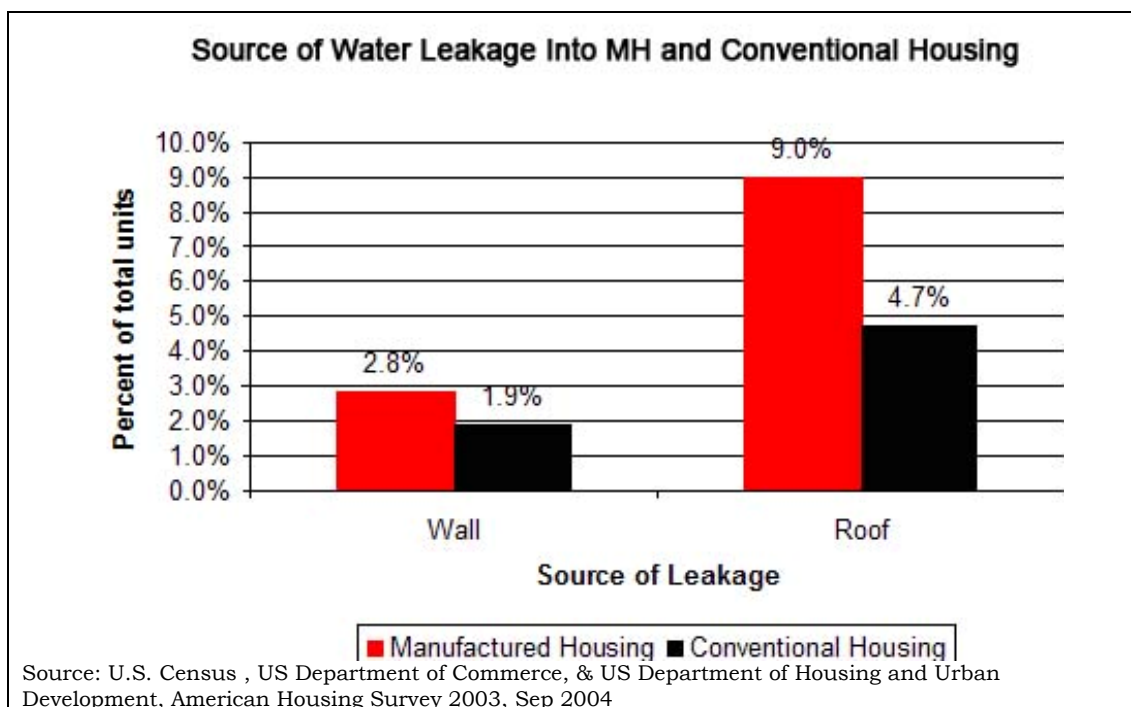

Figure 4.25 Percentage of manufactured and conventional housing units with walls and roofs as a source of water leakage

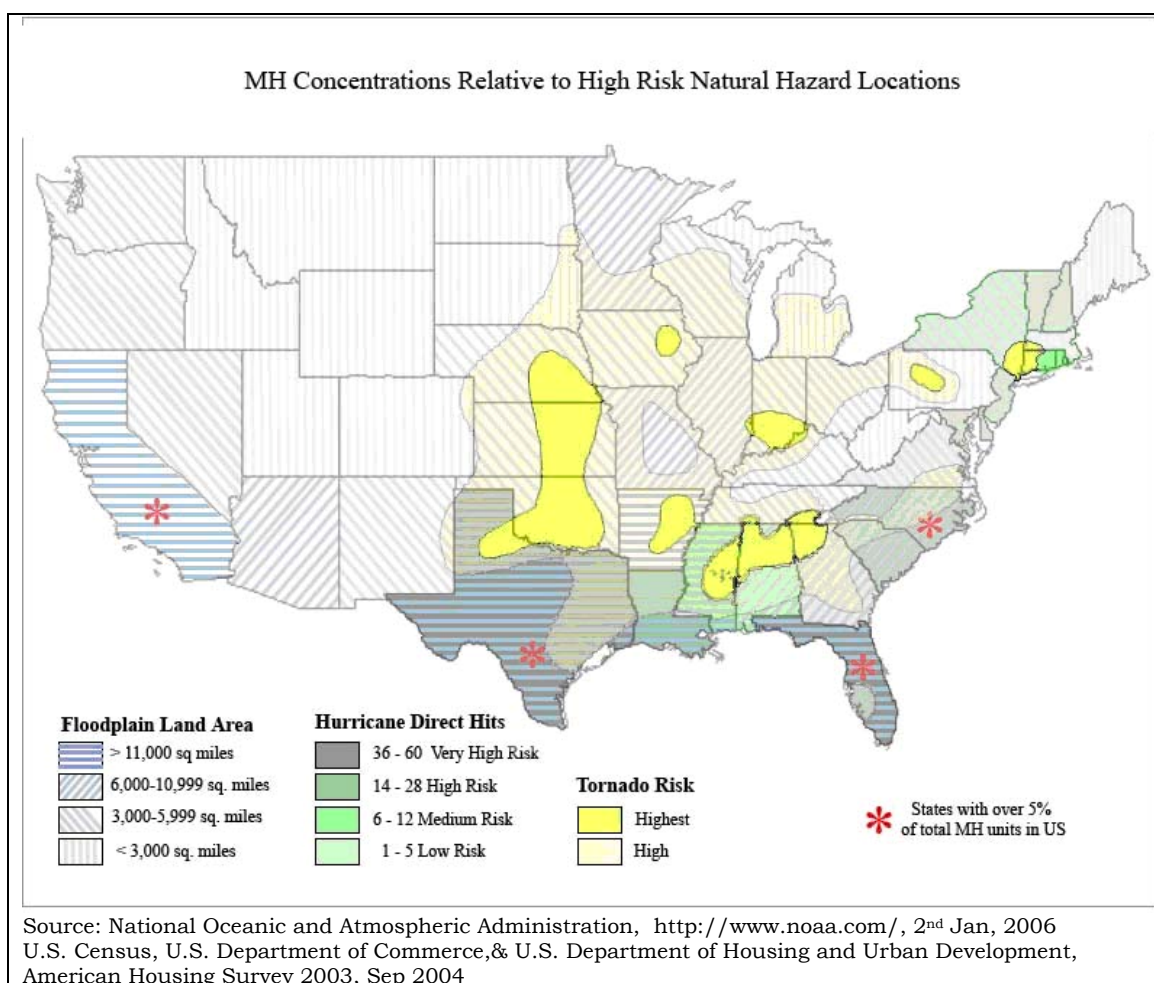

Figure 4.26 MH concentration locations relative to floodplain land areas, hurricane direct hits and, high risk tornado zones in the United States

Not only are manufactured homes more vulnerable to extreme weather effects because of their physical characteristics, they are, ironically, most located in areas with higher natural disaster risks (Fig 4.26). The three states with the highest percentage of occupied manufactured housing units, Florida (9.7%), Texas (8%), and North Carolina (7.6%)<sup>26</sup> are within high risk zones of tornadoes, hurricanes and Floods consequently contributing greatly to the annual \$2.4 billion lost due to flood damage in addition to

<sup>26</sup> Manufactured Housing Institute, Industry Statistics & Finance, Historical Industry Statistics, 5th Dec, '05, <http://www.manufacturedhousing.org/default.asp>

the highest fatality rate among all other natural disasters<sup>27</sup>. (Fig 4.27) illustrates the causes and effects of the manufactured home units vulnerability to extreme weather conditions.

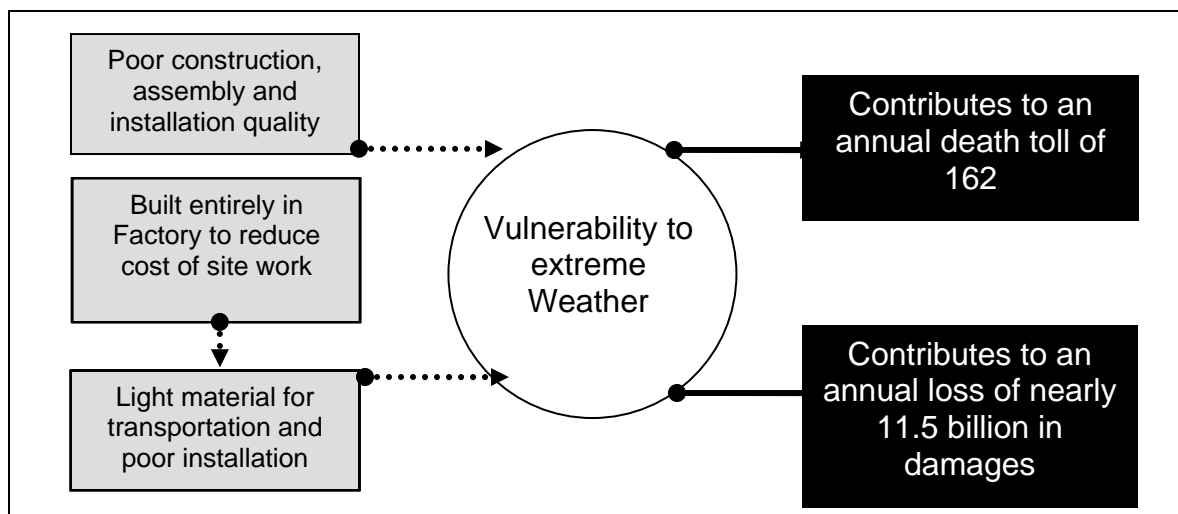

Figure 4.27 Causes and effects of the manufactured home units' vulnerability to extreme weather conditions

### Indoor Air Quality

Pressed wood products such as plywood, fiberboard, particleboards, and paneling forms a major part in the construction and furnishing of both manufactured and conventional housing. Such products in addition to wall insulation, and pressed draperies and fabrics may contain high quantities of formaldehyde as an adhesive base. Although this material has been found to cause adverse health effects such as eye, nose, and throat irritation; wheezing and coughing; fatigue; skin rash; severe allergic reactions as well as being designated by the environmental protection agency as a probable carcinogen<sup>28</sup>, it is still being extensively used in the production of construction

<sup>27</sup> NOAA, National Weather Service, Office of Climate Weather, and Weather Services, <http://www.weather.gov/os/hazstats.shtml> , 5th Dec, 2005

<sup>28</sup> US Environmental Protection Agency, Indoor Air Quality, Sources of Indoor Air Pollution-Formaldehyde, <http://www.epa.gov/iaq/formalde.html#Health%20Effects>, 2<sup>nd</sup> Jan, '06

elements and furniture for housing units. While other alternatives such as soy based adhesives have emerged lately, formaldehyde based adhesives are still dominant since they are very effective and economically viable for industrial use.

The world Health Organization recommends that a formaldehyde concentration limit of 0.05 ppm is not exceeded indoors<sup>29</sup>, however studies show that concentrations approaching and exceeding 0.3 ppm have been recorded in both manufactured and conventional houses. Residents in these homes have reported health disorders ranging from eye, nose and throat irritation to headaches and skin rashes<sup>30</sup>.

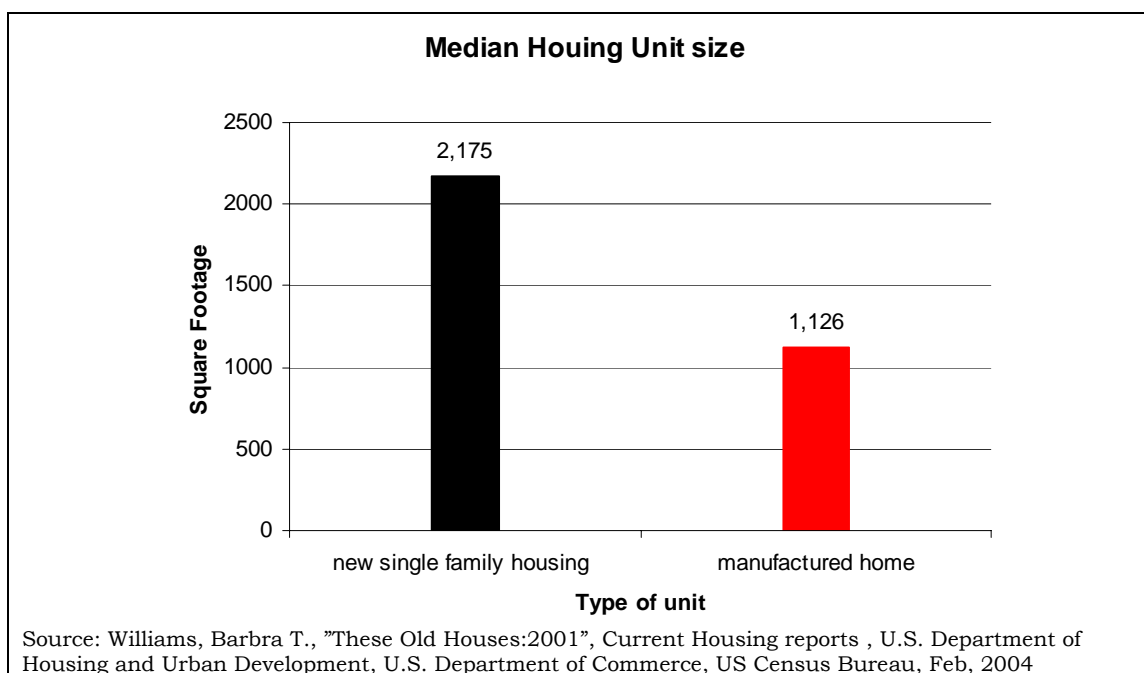

Figure 4.28 Median square footage of new conventional single family housing and MH housing built and manufactured (1990-2000)

Although formaldehyde is found in all types of residences, manufactured homes inevitably have higher concentrations as they are much smaller in size in comparison to

<sup>29</sup> Environmental Health Center, Formaldehyde, <http://www.nsc.org/ehc/indoor/formald.htm>, 2<sup>nd</sup> Jan, '06

<sup>30</sup> M. Ritchie, Ingrid, Robert G. Lehnen, "Formaldehyde Related Health Complaints of residents living in Mobile and Conventional Homes", American Journal of Public Health, 1987

the average conventional single family housing unit (Fig 4.28). In addition to that, as products containing this substance off gas excessively in high temperature and humidity levels, higher concentrations of formaldehyde are found in homes in the southern region renowned for it's hot humid weather. This region, as established earlier is where the majority of occupied manufactured homes are located. Furthermore, chronic respiratory diseases are the fourth leading cause of death for elderly citizens over 65 years in age<sup>31</sup> who form a substantial group of manufactured home residents. While the effects of formaldehyde alone may not be the direct cause of these disorders, they nonetheless play a factor in magnifying their symptoms when combined with the already fragile health state of the unit's occupant and thus contribute in a death toll of over 100,000 elderly on yearly basis and add to over \$ 200 billion in health expenses for individuals over 65 years in age<sup>32</sup>. (Fig 4.29) illustrated the causes and effects of the manufactured homes low indoor Air quality.

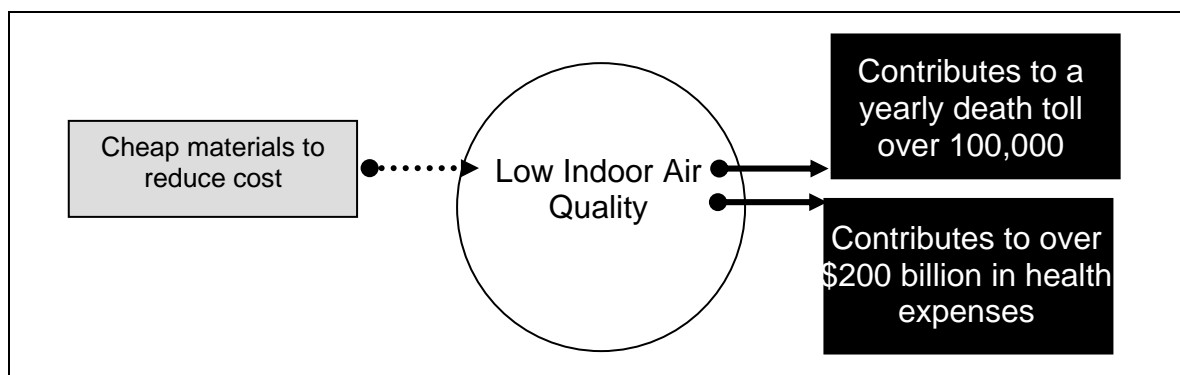

Figure 4.29 Causes and effects of manufactured home units' low indoor air quality

<sup>31</sup> US Department of Health and Human Services, "Health, United States, 2004 with Chart book on Trends in the Health of Americans", DHHS Publication, September 2004, p.159

<sup>32</sup> Ibid, p.184

### Financing and Insurance

Financing a manufactured home is a bleak issue. Generally, four financing options exist. These are the Federal Housing Administration Guaranteed Loans (FHA), Veterans Administration Guaranteed Loans (VA), Conventional Mortgages, and Personal Property Loans<sup>33</sup> (Table 4.1). However as the first three alternatives impose restrictions and requirements that in most cases could not be achieved by the average manufactured homeowner, such as a permanently fixed unit and ownership of the underlying land (Fig 4.30); Personal Property Loans dominate as the main method of financing<sup>34</sup>.

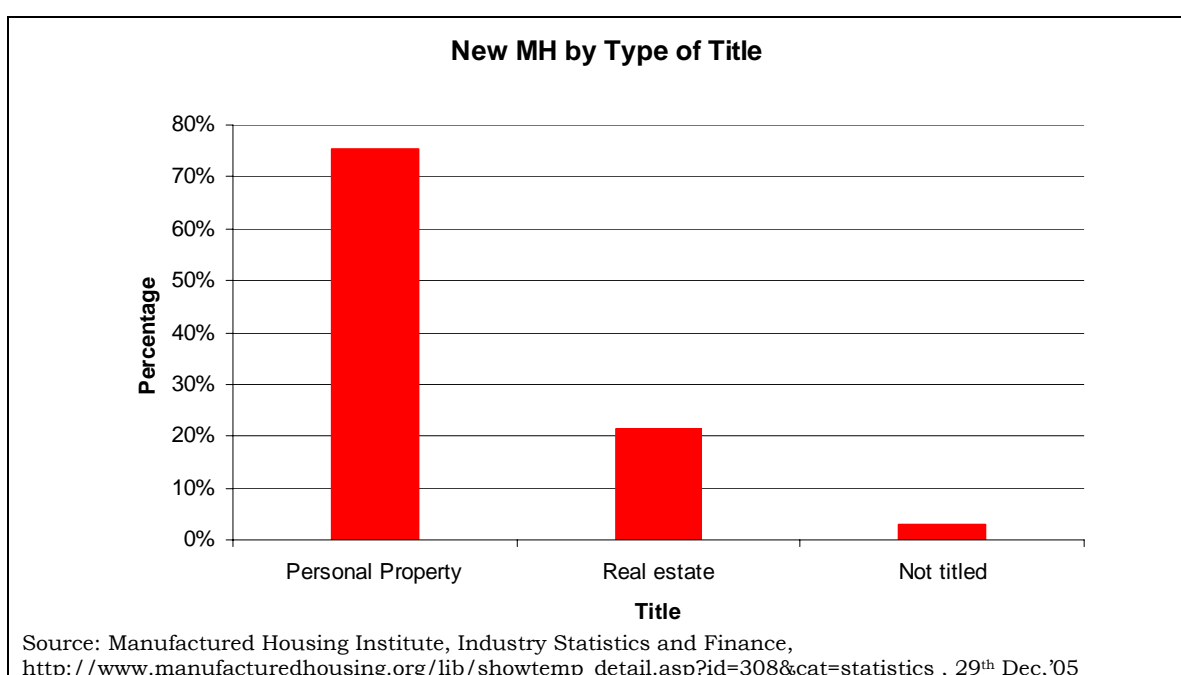

Figure 4.30 MH percentages by type of title

<sup>33</sup> Ibid p.328

<sup>34</sup> Manufactured Housing Institute, Industry Statistics & Finance, Historical Industry Statistics, 5th Dec, '05, <http://www.manufacturedhousing.org/default.asp>



Table 4.3 Financing options for manufactured homes and set requirements for each option.

Financing Options	Federal Housing Administration		Veterans Administration Guaranteed Loans	Conventional Mortgage	Personal Property Loans
	Title 1	Title 2			
Requirements	-Flexible offering options including land and home purchase, or land purchase only.	-Available for homes that are placed on permanent foundations.  -Requires the home and land to be financed under one loan- includes manufactured homes permanently sited on private property or on land in which the home buyer has qualifying leasehold interest.	Available to members of the armed forces or eligible veterans.	Home permanently built or placed on private property.	Typical of high cost, limited lifetime material items.
Maximum Loan Amount	Varies with the item to be financed	Higher than Title Loans	Guarantee of the lesser of 40% of the amount loan amount or \$ 20,000		No closing cost
Loan Term	15-25 yrs	30 yrs	15-25 yrs	Up to 30 yrs	5-15 yrs
Down Payment	5%-10%		No down payment		5%-15%
Interest Rate	Based on Market rates	2% lower than Title 1 loans		Based on market rates (currently not exceeding 6%)	At least 2 points higher than conventional mortgages

Source: NAHB Research Center, "Factory and Site Built Housing; A Comparison for the 21<sup>st</sup> Century", US Department of Housing & Urban Development, October 1998

Such Loans generally set down payment between 5% and 10%, have loan terms not exceeding 15 years, as well as interest rates averaging between 5.5% and 13% decreasing in value the more the manufactured home resembled a site built unit<sup>35</sup>. Conventional mortgages on the other hand generally require lower down payments, have loan terms as long as 30 years and do not exceed an interest rate of 6%. Furthermore, since personal loans are loans and not mortgages, the interest paid is not tax deductible as in the case of conventional housing<sup>36</sup>. In addition to that once titled as personal property, manufactured homes depreciate in value thus proving to be a poor financial investment to individuals who more often than not are in dire need for solid assets. The poor durability and performance, the fact that the unit depreciates at a fast rate and the limited financial resources of the manufactured home owner are also factors that play a role in increasing the interest rate as lenders have limited collateral when it comes to manufactured homes (Table 4.3).

The effects of the poor performance of the manufactured home extend further to influence insurance rates. Due to the high risk associated with the unit, Insurance policies for manufactured homes usually demand higher premiums and deductibles in comparison to conventional housing. The value is influenced by the physical characteristics of the structure and, as in the case of financing loans, decreases the more the unit resembles a conventional house. They are also influenced by the geographical location of the structure in terms of being within high risk tornado, hurricane and flood zones, which is where a high percentage of the existing occupied manufactured units are located as addressed previously. In addition to the high rates, insurance companies usually increase their premiums further or even refuse to renew

---

<sup>35</sup>Bankrate.com, "Financing a manufactured Home", 2<sup>nd</sup>Jan,'06, <http://www.bankrate.com/brm/news/mtg/19990722.asp>

<sup>36</sup> Ibid

policies for units located in high risk zones having multiple perils, this leaves the owner no choice other than agreeing to pay an even higher rate or take the chances of not having insurance coverage at all. This option however might further affect their financing interest rate increasing it as guarantees for the lender's investment decrease.

(Fig 4.31) illustrated the causes and effects of the difficulties associated with financing and insuring manufactured home units.

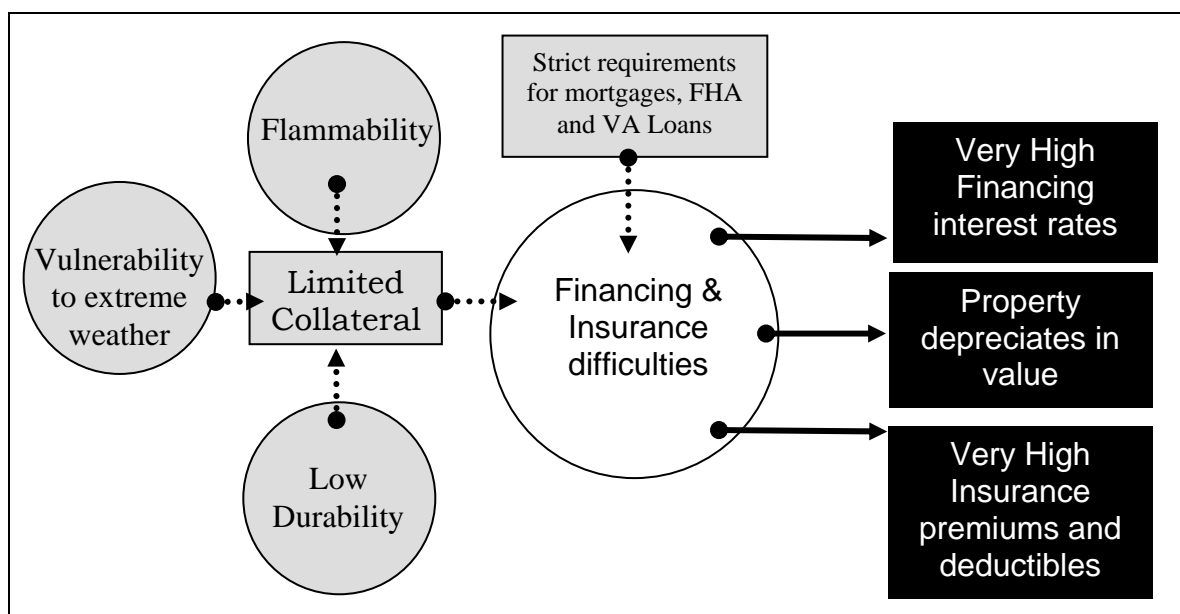

Figure 4.31 Causes and effects of manufactured home units' financing and insuring difficulties

#### Durability

In 1999, the National Family Opinion Research Center approached by the American Association of Retired Persons conducted a survey on a nationally representative sample of 944 manufactured home units. The survey's aim was to detect the physical problems relating to construction and installation of manufactured home units purchased after 1990.

The survey showed that over three quarters of manufactured home units faced one problem at least relating to its construction and/or installation. It also concluded that

over half these problems were detected within the first year of occupancy of the unit which raises issues regarding the durability of the manufactured housing unit. The most reported problems were relating to interior fittings and finishes, ill fitting doors and windows, plumbing, leaks and other problems related to general construction (Fig 4.32) with over half the surveyed units reporting two or more simultaneous deficiencies.

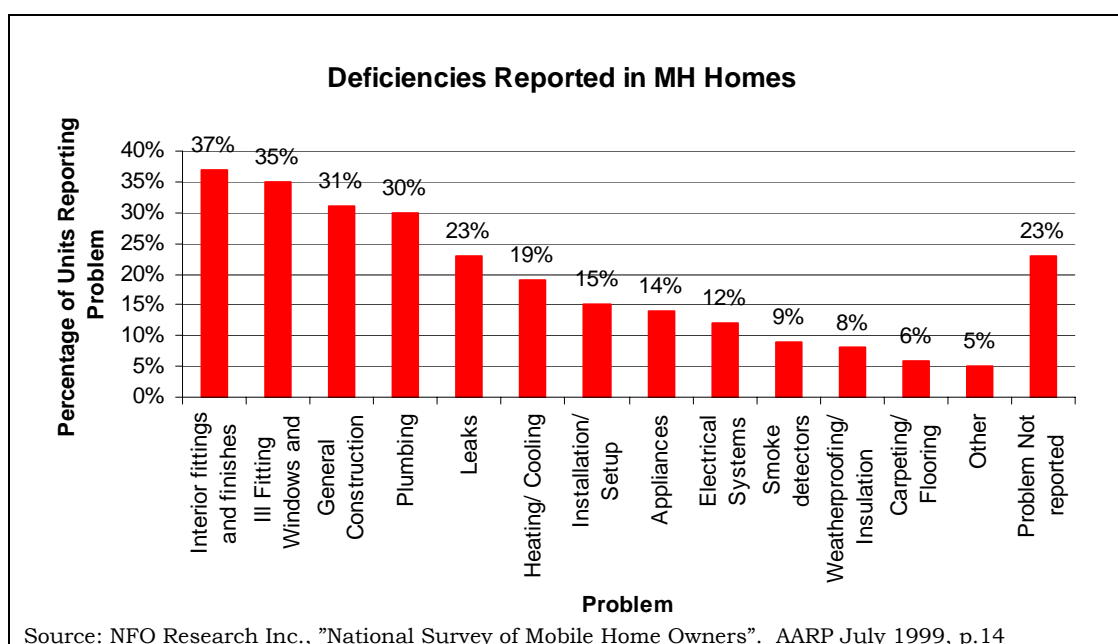

Figure 4.32 MH units suffering from specific deficiencies as percentage of Total MH units surveyed

This is perhaps explained by the construction material and construction methodologies associated with the production of the manufactured home as the producers try to maintain a low price tag attractive to the typical manufactured home resident. However economizing in material and production costs may entail- in addition to the residents' inconvenience- further financial implications not reflected by its initial unit price. Results from the same survey also conclude that the cost of fixing the problems reported averaged over \$1000 per problem (Fig 4.33) which may be a sum quite restrictive to a household with limited income especially when multiple defects are

detected in the unit. (Fig 4.34) illustrated the causes and effects of the lack of durability in manufactured home units.

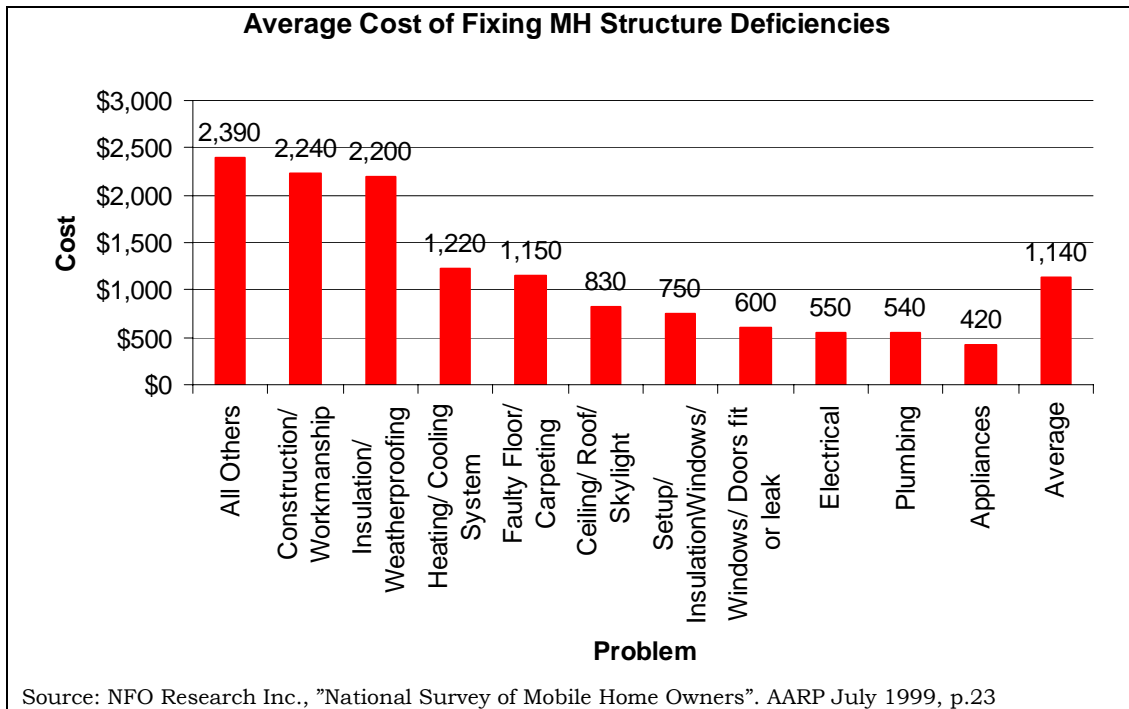

Figure 4.33 Cost of fixing deficiencies in MH units

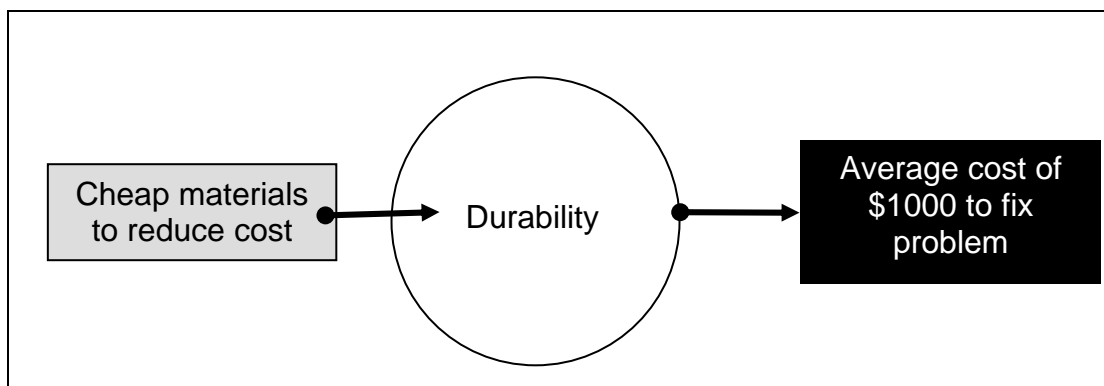

Figure 4.34 Causes and effects of manufactured home units' lack of durability

Transportation

Transporting and installing the finished manufactured housing unit poses several limitations on design and production decisions. As the unit is hauled along highways

before it finally arrives at its site to be installed, highway lane widths inevitably determine the unit's width restricting it to no more than 15 ft in most states. The height of the unit is generally limited to 7 ft to ensure its smooth passage under overhangs and through tunnels<sup>37</sup>. While these considerations affect the form and aesthetic of manufactured homes transforming them to compressed elongated boxes, there are other considerations that contribute to their excessive flammability and poor performance in extreme weather conditions as discussed earlier. To eliminate complications during transportation such as excessive pressure on the tires supporting the chassis and moving the units along the street, an effort is made to keep the weight of the unit at a minimum. This influences the choice of material used in construction restricting it to lightweight thin members. While these measures are considered necessary in order to ensure the safe travel of the unit, a question arises of whether compromising its aesthetics and performance is offset by a one time trip as more than half the manufactured home units (60%) are never moved from their initial location<sup>38</sup>.

Moreover, limiting the size and weight of the unit does not eliminate all the complications associated with its transportation as the process remains both dangerous and costly. Serious damages to the unit itself is not the only concern, as parts of the unit that are mishandled or initially poorly fastened in place might detach during transport harming both individuals and property. In addition to that, replacing damaged equipment that were used during the process, such as tires and axes, is very costly adding hidden expenses to the already expensive overall transportation cost (Table 4.4).

---

<sup>37</sup> NAHB Research Center Inc., "Factory and Site Built Housing; A Comparison for The 21st Century U.S". Department of Housing and Urban Development, October 1998. p 38

<sup>38</sup> American Housing Survey for the United States:2001, Current Housing Reports, US Department of Commerce & US Department of Housing and Urban Development, October 2002

Table 4.4 Average costs associated with transportation of manufactured home units

		Single Wide	Double Wide
Per Mile rate		\$ 4.85	\$ 4.85
Take Down		\$ 1,200	\$ 2,300
Set Up		\$1,200	\$ 2,300
Additional Costs	Hitches	\$ 250	\$ 250
	Tire Damage (per tire)	\$ 30	\$ 30
	Axle Damage (per axle)	\$ 100	\$ 100
	Permit	Per State	Per State
	Over weight Fines	Per State	Per State
	Hooking Up Fines	\$ 450	\$ 450

Another issue of relation is installation of the unit which incurs an additional cost not included in the original price tag. The initial financial installation cost, while important, may not be the prime concern in view of the serious problems that arise due to poor installation which consequently leads to shortcomings in terms of durability and performance of the unit. The survey conducted by the National Family Opinion Center recorded several problems in manufactured homes due to improper installation (Fig 4.35) most of which (85%) appeared within the first year of occupancy and cost \$750 on average to fix<sup>39</sup>. (Fig 4.36) illustrated the causes and effects of the problems associated with transportation of manufactured home units.

<sup>39</sup> NFO Research Inc., "National Survey of Mobile Home Owners". AARP July 1999, p.

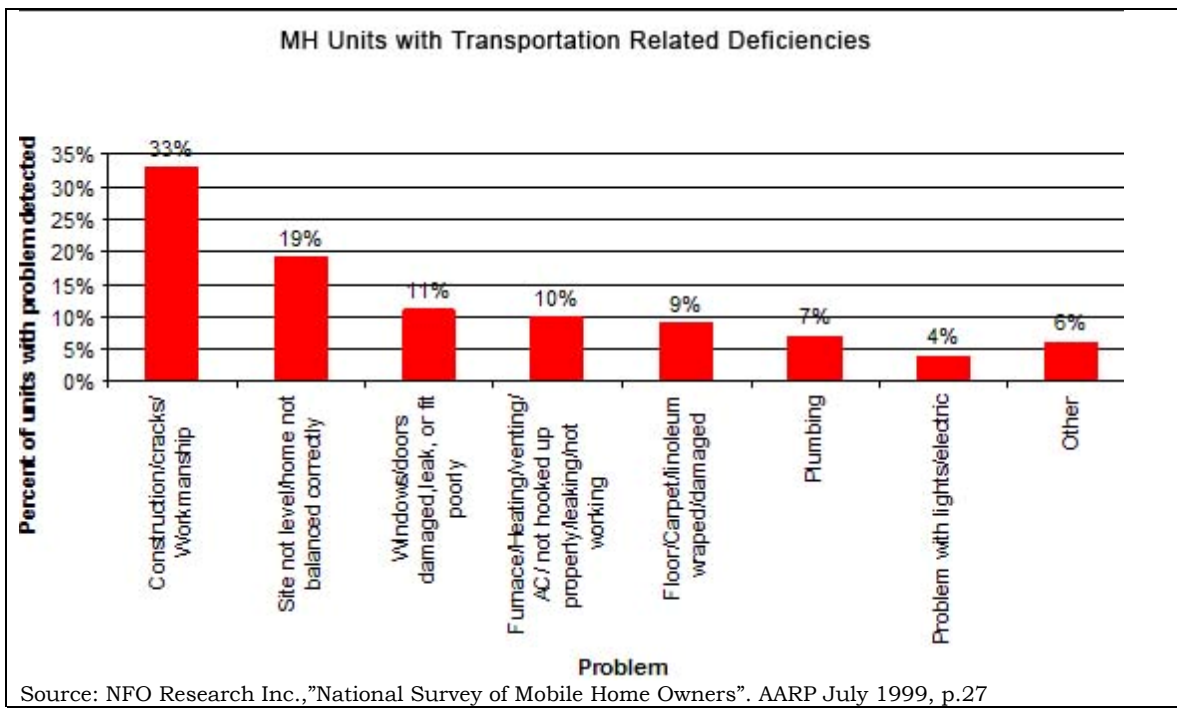

Figure 4.35 MH units suffering from deficiencies due to improper installation as percentage of Total MH units surveyed

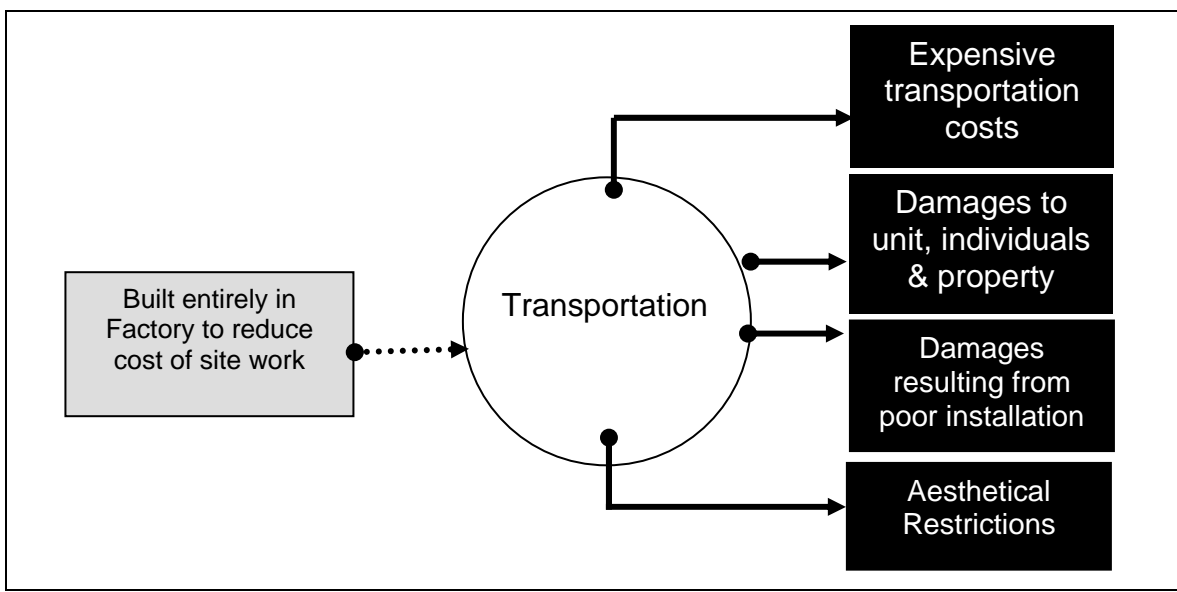

Figure 4.36 Causes and effects of manufactured home units' transportation difficulties



### Aesthetics, Perception, and Zoning and Regulations

The form and aesthetic of the manufactured home unit succumb to several restrictions due to production methodologies, transportation limitations and financial implications that dictate material choices and design decisions. Although in the past few years, new high end manufactured home models that greatly resemble conventional housing emerged such as those in Noji Gardens in Seattle (Fig 4.47) and the Mills of Carthage Community in Ohio, the prices of such models are within the range of a conventional stick built home costing between \$160,000 and \$260,000<sup>40</sup> and therefore are out of the reach of the typical manufactured home buyer who is mainly attracted to manufactured homes because of their affordability in comparison to conventional home prices. The result is a prevalent more affordable compressed utilitarian box-like appearance limited in variety despite the manufacturers' attempts to create a sense of diversity by a superficial change in color, fixtures, elevation treatments and minor alteration in floor plan organization. This lacking aesthetic contributes along side its other deficiencies and performance shortcomings in the creation of a negative perception and prejudice against the manufactured home unit.



Figure 4.37 Noji Gardens' manufactured homes in comparison to the traditional manufactured housing units

<sup>40</sup> Home Sight, " Noji Gardens", Dec 20<sup>th</sup>, 05 <http://homesightwa.org/devnoji.htm>

This prejudice manifests itself in the form of what came to be known as the “not in my back yard” (NIMBY) syndrome as local authorities and conventional single family housing communities work to exclude manufactured homes from their districts despite federal legislation that encourage including affordable and low cost housing in general and manufactured homes in particular within single family conventional housing subdivisions. This bias is often attributed to issues regarding performance and aesthetic as well as fear of depreciation of community lots as mentioned earlier, in addition to the perception of the typical manufactured homeowners as undesirable unlawful undeserving individuals with no morals or respect for people and no ties or responsibilities<sup>41</sup>. Whether such bias is justified or not is an irrelevant issue, however as a consequence, manufactured homes are thereby usually placed in the least desirable locations with limited or low quality amenities and services at the edge of towns and cities or next to industrial plants or in agricultural areas away from jobs (Fig4.38).

---

<sup>41</sup> Bean, Janet L., “The NIMBY Syndrome and Low-Cost Manufactured Housing Developments: Can Landscape Architecture Help Overcome Community Opposition?”, Virginia Tech. University, 13<sup>th</sup> Feb, 2004, Chap.1, p.5.

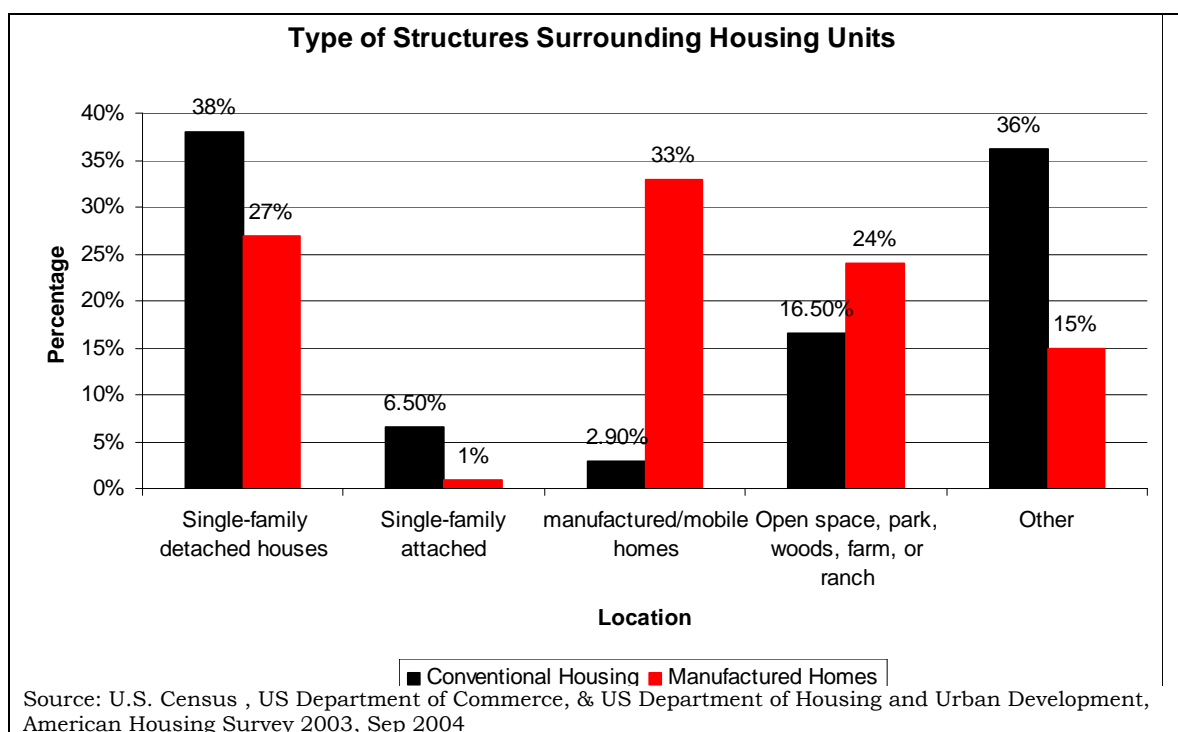

Figure 4.38 Percentage of MH and conventional housing units by placement location

Another complication in this situation emerges when owners of manufactured homes placed in land/lease communities in such locations are forced to leave these communities as they are sold to developers who plan to replace these parks with high end condominiums, office blocks or shopping malls as land prices shoot up. Owners of these units who are in most cases elderly individuals, are confronted with the ordeal of looking for another manufactured home community that they can afford in addition to transportation costs and difficulties let alone losing a style of life and setting which they had gotten accustomed to. (Fig 4.39) illustrates a summary of the causes and effects of the problem of the lacking aesthetic of the manufactured home unit.

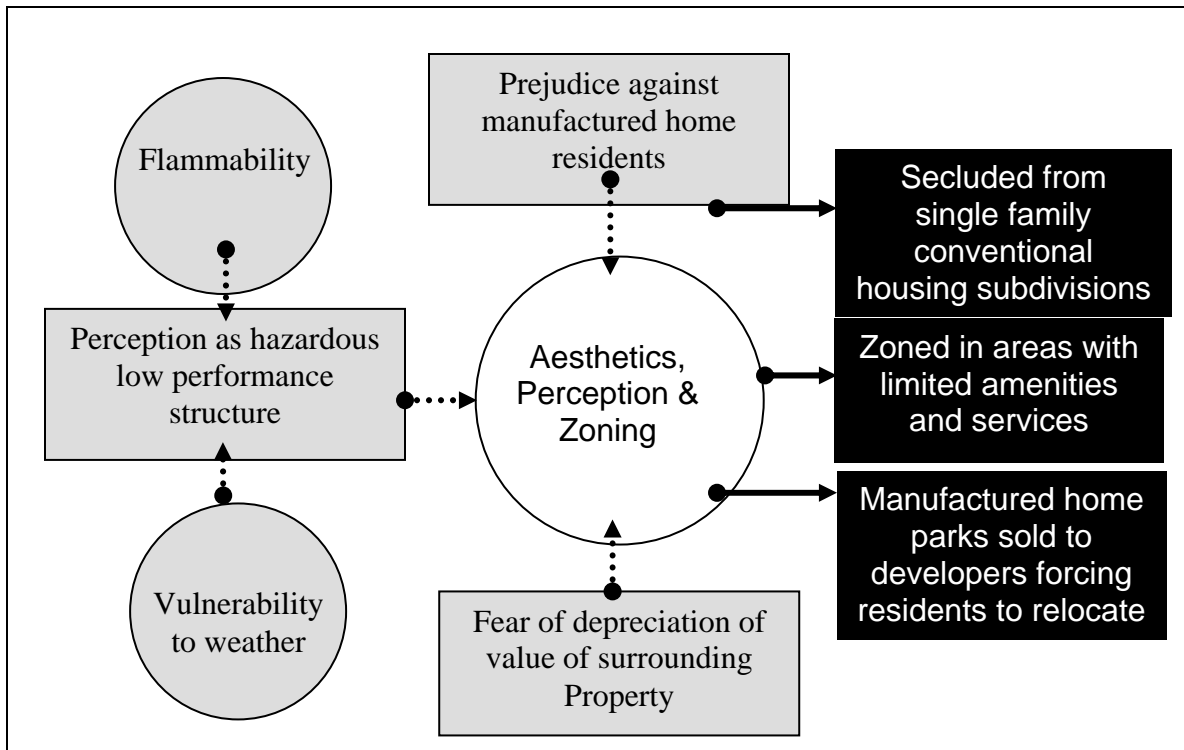

Figure 4.39 Causes and effects of manufactured home units' low aesthetic appeal, negative perception and prejudiced zoning laws

### Conclusion

The manufactured home unit emerged as an affordable housing alternative adapting to people's circumstances over the past century. Manufactured homes dominate other factory built housing typologies that include modular, panelized and precut units. Though these units share the fact that they are all factory built, they differ in terms of being assembled on site rather than in the factory environment.

The production process of the manufactured home unit mimics that of conventional housing structures. Thus it could be concluded that the manufacturing process does not take full advantage of the factory environment. In addition to that, the dedication of the industry to minimize production cost adversely affects the quality of the structure both in terms of performance and aesthetics giving way to several deficiencies. In light of these deficiencies the manufactured home is gradually losing its appeal as an

affordable housing unit. Nevertheless, since it requires minimum site work and therefore less time for assembly, it is increasingly taking the role of a fast housing solution following natural disasters. This brings to light another problem, that of these hazardous housing units being increasingly placed in regions prone to natural disasters (Appendix C).

**Key Points**

- Mobile homes evolved from the early models of the automobile and the recreation trailers as prices decreased due to Henry Ford's utilization of the principals of mass production and the assembly line. The mobile home surfaced as emergency and war housing and later established itself as the affordable housing solution as conventional housing prices increased beyond the reach of households with limited income in the second half of the 20<sup>th</sup> century.
- Huge demand boosted the industry at the time, yet the industry's profits plunged once quality control was reinforced through the HUD code in the 1970's which was reflected in a change in nomenclature in the 1980's.
- Manufactured home residents form a distinct sector of the population. They are mainly retired elderly or young married couples who are mainly attracted to the manufactured housing unit due to their financial limitations.
- Manufactured homes have the highest shipment rate among all other factory built housing due to its maintaining the lowest price.
- In the past years manufactured home shipments and sales declined in comparison to conventional single family housing units that formed a higher percentage of completions and sales despite their increasing prices that far exceed manufactured home units' prices. This suggests that manufactured homes are losing their appeal as an affordable housing alternative.
- As the manufactured home industry continues to serve as the low-income affordable housing solution today, the industry strives to maintain its financial appeal, the main asset of the manufactured home, by keeping production costs down and increasing production eliminating technology or computerization in production and solely relying on manual labor site built homes construction methodology despite the factory environment.

- Mainly due to low quality construction material and construction processes, the manufactured home units face several problems.
- The need to keep the unit light for transportation to site as well as the producer's tendency to economize on cost by the use of cheaper light produces an excessively flammable structure that has the highest death rate per thousand fires among all other types of residential and non residential buildings, killing 271 people annually mostly elderly and costs about \$120,000 in yearly losses.
- The need to keep the structure light for transportation, the use of lighter material to economize on cost as well as the form of manufactured home unit and its poor installation techniques makes it vulnerable to wind and flood damage contributing to an annual fatality rate of 162 people and annual dollar loss exceeding \$11.5 billion due to severe weather conditions.
- The need to economize on cost leads to the use of cheap material that excessively emit noxious fumes that have adverse health effects and contributes to a yearly death toll of over 100,000 elderly over 65 years in age who die due to chronic respiratory diseases (4th leading cause of death among this age group) and contributes to an annual elderly health expenditure exceeding \$200 billion.
- Strict regulations and requirements for conventional, FHA, and VA loans as well as the limited collateral when it comes to manufactured homes in light of its performance related problems makes personal property loans the only option to finance manufactured homes despite the higher interest rates which are not tax deductible, shorter loan periods and the units' depreciation in value.
- Insurance rates for manufactured homes are higher than conventional homes due to the higher risk associated with the units in light of their poor performance and due to their location in high risk zones.

- Due to the use of cheaper material and poor construction material to minimize cost, the units have limited durability with simultaneous problems relating to construction emerging within the first year of ownership and costing \$1000 on average to fix.
- The need to reduce cost by constructing the entire unit in the factory thus keeping site work assembly to a minimum imposes several restrictions on form and aesthetics as well as the necessity to keep the unit light for transportation and installation. Regardless of efforts to keep the unit light, problems during transportation and installation still arise as the process is both dangerous and expensive.
- All the performance related problems associated with manufactured homes feed into the perception of these units as hazardous low quality units. This in addition to fear of damage and depreciation of value of surrounding property as well as the negative image of the manufactured home owner, leads to local governments laws that mandate zoning manufactured homes out of single family housing communities to edges of cities away from jobs and services.
- Manufactured home developments are increasingly being sold out to developers as land prices increase which forces manufactured homeowners in these land/lease communities to relocate. This brings up problems relating to transportation.
- Manufactured homes came about as the industry's solution to the mass housing dilemma. As Gropius has predicted, the industry has acted alone in the absence of leading architects. The result of the industry's attempt is a low price yet low quality structure.
- Though the problems associated with manufactured homes are very severe, they are in essence the same as those confronted by architects exploring mass



housing in the past century. Mainly relating to performance and aesthetics although they are more exaggerated when it come to manufactured homes.

CHAPTER V  
TECHNOLOGY AND ARCHITECTURE

**Introduction**

As illustrated in Chapter 4, the lack of integration of appropriate technological application in the design and production process of the factory built home is one of several factors leading to the problems associated with factory built housing structures. This is however not a reflection of a lack of utilization of technological applications in architecture.

In a lecture at the School of Architecture at Mississippi State University, architect Gregg A. Pasquarelli of SHoP Architects enthusiastically expressed, “It is great to be an architect today!...” Mr. Pasquarelli was referring to the prevailing mood within the architecture profession where lines defining limitations are blurred as technologies, used in other industries, penetrate into the profession shaping new possibilities. Though the introduction of these technologies was late and slow relative to its use in industry, their impact is quite vivid and their use in design and construction is taking place at an accelerating rate as architects engage in exploring new avenues in their application in the architectural design and construction process.

This chapter aims to highlight some of the major emerging trends in integrating technology in the architectural design and construction process.

**Early Applications**

The use of computer technologies on a wide scope in design and construction could be traced back to the 1960’s when it was used to aid the design and construction

process for the Sydney Opera House (Fig.5.1). Both Ove Arup and Jack Zunz, the project's engineers expressed that:

*“It was clear in those early days that to achieve a solution at all, to make it possible to build the structure, extensive use of electronic digital computers was necessary. It would otherwise have been almost impossible to cope with the sheer quantity of geometric problems, let alone the complexity of the analytical work.”<sup>1</sup>*

As opposed to the automobile and aerospace industry, computer software that is specific for architectural applications was not available at that time, therefore a FORTRAN based software was written to aid with the generation and analysis of the shape of the curves and to help define the geometry of the glazing relative to the form of the shells as it was tweaked and modified<sup>2</sup>. In addition to that the software was utilized to carry out structural analysis for the shells' concrete ribs as well as for the structural glazing surfaces.

Another major role that the computer played in this project was the determination of the shape configurations for the roof tile panels that clad the structural concrete ribs. Due to the shape of the shells, around 1 million concrete tiles were needed and were pre-cast using 25 different concrete roof lids of which only six were highly standardized (Fig 5.1)<sup>3</sup>. These tiles were encoded following a computer generated database in order to keep record of their dimensions for prefabrication and their location to facilitate site assembly. In a similar manner, the shapes of 2000 glass panes for glazed surfaces were defined in 700 different variations to be cut using CNC

---

<sup>1</sup> Shodek, Daniel, Martin Bechthold, Kim Griggs, Kenneth Martin Kao, Marco Steinberg, “ Digital Design and Manufacturing”, John Wiley & Sons, 2005, p.29

<sup>2</sup> Ibid, p.29

<sup>3</sup> Ibid, p.31

machinery<sup>4</sup> (Fig 5.2). Moreover, the computer also aided the verification of as built construction and adapted necessary changes to glass panes to ensure a perfect fit<sup>5</sup>.

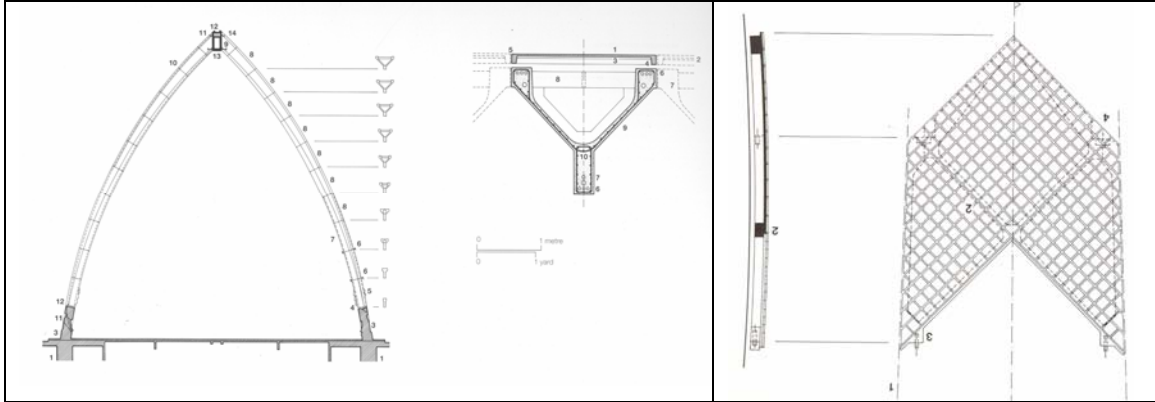

Figure 5.1 Variation in roof tile shapes

Figure 5.2 Variation in glass pane shapes

Similarly, Computer Aided design played an important role in the design and construction of the Kansai Airport in Osaka, Japan between 1988 and 1992. Architects at Renzo Piano Building workshop in collaboration with Ove Arup & partners and Nikkien Sekkei utilized digital models to help generate the form of the building based on structural and computer fluid dynamic studies<sup>6</sup>. Computer studies were further incorporated to define the shape of a standard cladding roofing panel of which 82,000 panels were fabricated to clad the structural steel truss<sup>7</sup>. Although the fabrication of the roof panels was simplified through standardization, the fabrication of the curved structural truss supporting these panels necessitated intensive digital analysis to specify the length and curvature of the steel sections as well as intersection points of the primary truss with the secondary structure and with the roof panels (Fig.5.3 & 5.4).

<sup>4</sup> Ibid p.32

<sup>5</sup> Ibid, p.34.

<sup>6</sup> Piano, Renzo, "Renzo Piano: Building Workshop: In Search of a Balance, Process Architecture, 1992, p.227

<sup>7</sup> Shodek, Bechthold, Griggs, Kao, Steinberg, "Digital Design and Manufacturing", p.36

To maintain the curved form, the structural truss was fabricated from several segments that varied in length and curvature and points of intersection with other structural segments thus requiring robotic welding to ensure accuracy of construction<sup>8</sup>.

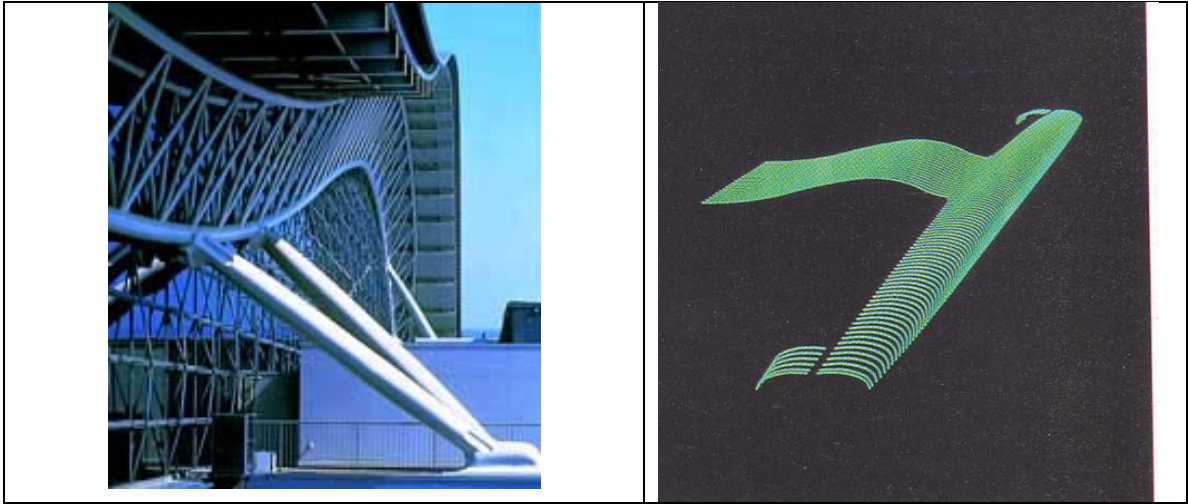

Figure 5.3 Structural support of the Kansai Airport, Japan



Figure 5.4 Digital analysis and curvature studies

The previous projects illustrate the early applications of computer aided design and manufacturing in architecture and its impact in terms of bringing to realization previously inconceivable forms.

### **Architecture of Frank O. Gehry & Partners**

The limits to which digital capabilities influenced design and construction of complexly curved forms were stretched further in the work of Frank O. Gehry and partners; specifically in projects that took place after 1989. Gehry's practice had until that point never engaged the use of the computer in their design process<sup>9</sup> which relied mainly on generating 2D drawings from physical models that the design team built and

<sup>8</sup> Shodek, Bechthold, Griggs, Kao, Steinberg, "Digital Design and Manufacturing", p.36.

<sup>9</sup> Lindsey, Bruce, "Digital Gehry; Material Resistance/ Digital Construction", Birkhauser, 2001, p.34

tweaked as the form evolved<sup>10</sup>. The Great Olympic Fish designed for the Barcelona Olympics in 1989 proved to be a challenge in terms of conveying fabrication and construction information to builders through the use of Gehry's conventional method. Drawings generated from the physical models appeared to be flawed following studies conducted by William Mitchell and Evan Smythe at Harvard<sup>11</sup>. Furthermore, Alias Studio, the software used for these studies, approximates surface information of the model based on a polygon grid thus lacking the accuracy needed for construction. This obstacle led to a search for another digital environment capable of generating reliable information to be passed on to fabricators. CATIA, developed by Dassault systems for the design and production of the Mirage fighter jets, described geometry accurately through polynomial equations<sup>12</sup>, thus answering to the needs of the design team. The 2D drawings generated from CATIA by Permasteelisa, the cladding contractor, facilitated the exact definition of the shape of the steel strips used to clad the structural steel struts through the production of templates to guide their cutting<sup>13</sup>

Due to the high level of variety in the types, orientation and location of connections as well as the inconsistency of the lengths of the tubes supporting the cladding, where no two tubes were identical in length, Permasteelisa failed for six times to fabricate an accurate full scale component mock-up from the 2D drawings alone<sup>14</sup>. As a solution, a set of standard flexible fittings were designed to be assembled using information obtained directly from the CATIA model accurately defining each fitting's

---

<sup>10</sup> Ibid p.49-65

<sup>11</sup> Ibid, p.34

<sup>12</sup> Ibid, p.34

<sup>13</sup> Shodek, Bechthold, Griggs, Kao, Steinberg, " Digital Design and Manufacturing", p.42.

<sup>14</sup> Lindsey, "Digital Gehry; Material Resistance/ Digital Construction", p.38

position and orientation<sup>15</sup>. Based on this method a total of only 6 drawings supplemented the digital model for construction making this a nearly paperless fabrication project<sup>16</sup> that depended on CATIA to keep record of the information related to the assembly of the various unique parts and components although the software did not play any role in the initial design and form finding process (Fig.5.5).

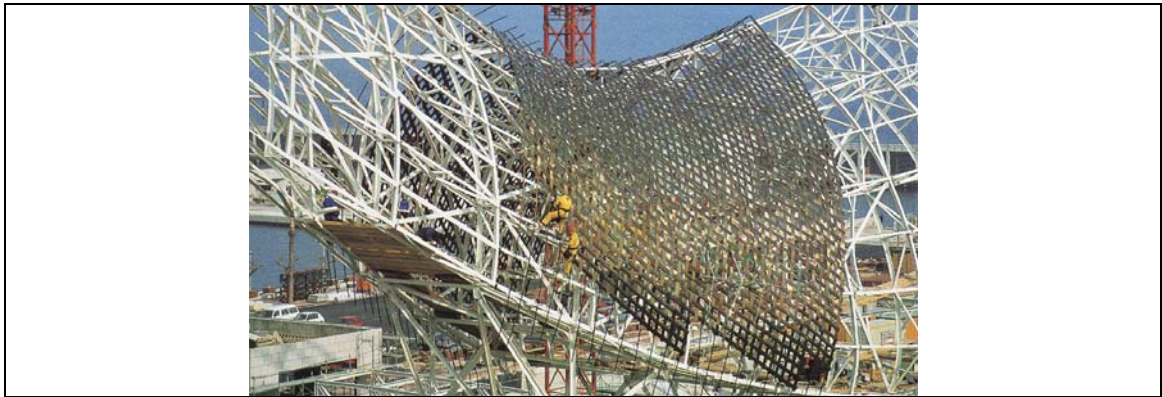

Figure 5.5 Assembly of the Olympic fish project based on information obtained directly from the CATIA digital model

The success achieved through the Great Olympic Fish project had great impact on the design development methodology at FOGA. While the conceptual development stage continued to rely solely on sketches and physical model studies to define the expressive forms characterizing the practice, digital capabilities intervene in the following stages to make these forms meet the rules of structure and gravity, the characteristics of materials and the realities of construction.

This occurs through the process of first digitizing the physical models in order to transfer information defining form into the digital realm. High end technology used in

<sup>15</sup> Dal Co, Francesco, Kurt W. Forster, Hadley Arnold, "Frank O. Gehry, The Complete Works", The Monacelli Press, 1998, p. 431.

<sup>16</sup> Kolarevic, Branko, Jim Glymph," Architecture in the Digital Age; Design and Manufacturing; Chap 8: Evolution of The Digital Design Process", Spon Press,2003,p.108.

medicine such as the FARO digitizers initially used in preparation for spine surgery and CAT scans (Computer Axial Tomography) used to obtain brain cross sectional scans facilitate this process<sup>17</sup>. The information obtained is then used to create surfaces defining the 3D digital model. When verification of the form of the digital model is needed, physical models are built from the digital information through CNC media.

One or more digital models could be obtained through this process, depending on the component of the project that needs study, whether the exterior surface, the interior surface, or the most crucial, a wireframe model used for the study of structure and systems, generally referred to as the “master model”<sup>18</sup>. These models form the basis on which rationalization of the project takes place. This phase is where the digital capabilities of computers and software play the major role in transforming the model from a mere shape to an actual building through imposing rules that replicate structural and material behavior in terms of size limitations, connections and joints, overall aesthetic and construction constraints, among many other variables, in preparation for the subsequent construction phase. The Disney Concert Hall digital model was rationalized to take into account the characteristics of the exterior metal cladding<sup>19</sup> (Fig.5.6). Similarly, several layout compositions of the metal surface shingles were generated and studied for the EMP Experience Music Project in Seattle through the use of the CATIA digital model<sup>20</sup>. In addition to that, the CATIA model also

---

<sup>17</sup> Lindsey, “Digital Gehry; Material Resistance/ Digital Construction”, p.65-67

<sup>18</sup> Ibid, p.39

<sup>19</sup> Kolarevic, Glymph,” Architecture in the Digital Age; Design and Manufacturing; Chap 8: Evolution of The Digital Design Process”, ,p.110.

<sup>20</sup> Lindsey, “Digital Gehry; Material Resistance/ Digital Construction”, p.72



facilitated the rationalization of the curved roof form of the EMP project to account for wind loads and conduct sun studies<sup>21</sup>.

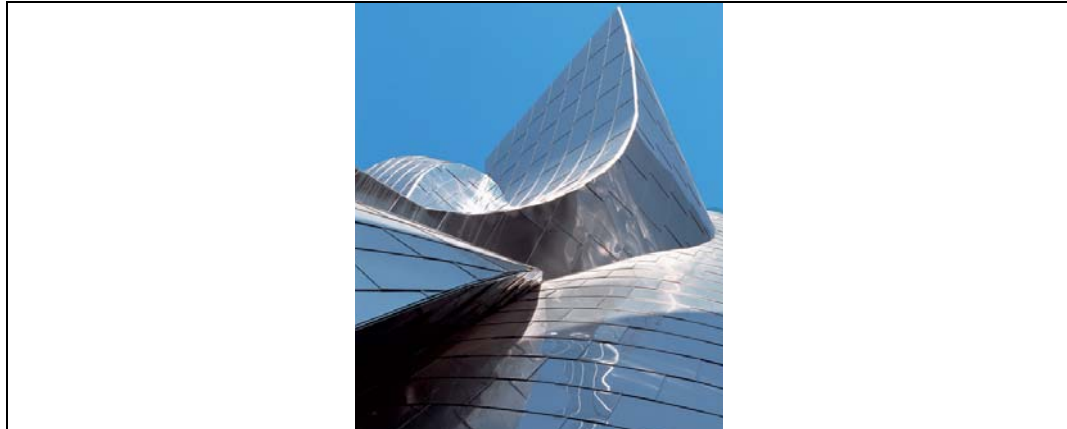

Figure 5.6 Exterior metal cladding of Disney Concert Hall

Furthermore, the impact of technology on the construction process is not limited to transforming construction and fabrication methodologies through the use of CNC machine capabilities, but extend to the provision of a database that organizes the massive details and information obtained during the rationalization of the project, and generates construction and assemblage information on as needed bases. This is clearly illustrated in several of Gehry's projects; one of which is the EMP where CNC cutters were used to fabricate structural steel flanges and CNC rollers facilitated rolling them to curves of no specific continuous radii to an extent that none of the 239 ribs were identical and no 2 feet of length in any rib had repeated curvature values<sup>22</sup>. The CATIA model also provided means for developing template details and keeping record of the data needed for the prefabrication of 21,000 different stainless steel and aluminum shingles used to assemble 4,800 panels for the skin of the EMP project<sup>23</sup> (Fig.5.7). For

---

<sup>21</sup> Ibid, p.75

<sup>22</sup> Ibid, p.86

the Zollhof Towers in Dusseldorf, Germany, information obtained through rationalization facilitated CNC routing 335 different Styrofoam forms used to cast the concrete panels and aided the generation of the specific details necessary for the fabrication of 1600 different operable windows<sup>24</sup> (Fig 5.8).



Figure 5.7 Exterior façade of the EMP project



Figure 5.8 Façade of the Zollhof Towers in Germany

In comment on how the computer and CATIA in particular influenced his work, Gehry expressed:

*“This technology provided a way for me to get closer to the craft. In the past, there were many layers between my rough sketches and the final building, and the feeling of the design could get lost before it reached the craftsman. It feels like I have been speaking a foreign language, and now, all of a sudden, the craftsman understands me.”*<sup>25</sup>

Indeed this newfound understanding between architect and craftsman did not only enable communication through which the architect’s intent is depicted seamlessly on a level unsurpassed previously, but also gave birth to a new expressive language in architecture where variety, diversity and multiplicity of complex forms and detail are operative keywords.

---

<sup>23</sup> Ibid, p.86

<sup>24</sup> Ibid, p.80

<sup>25</sup> Ibid, p.84

### **Architecture of Foster & Partners**

As different practices adapting different methodologies realized the potential application of recently emerging technologies in the field of architecture, they embarked, as did Gehry, on integrating its use within their design process in the manner they perceived most suiting their philosophy and principles. Sir Norman Foster, another pioneer in the field hinted to the effect that digital capabilities had on his practice as he said in 2000, “We now have at our disposal digital design tools that are enabling us to realize buildings which only 30 years ago were beyond our capabilities”.<sup>26</sup>

This transformation at Foster and Partners is a reflection of the changes that occurred in the design process as computational capabilities were integrated at the very early stages of the conceptual development of projects. The Specialist Modeling Group (SMG<sup>27</sup>) was established within the practice to enhance the work of architects and designers as it aids their use of the digital tools by providing expertise and studies throughout the process from conception to realization.

Based on an initial idea, SMG provides one or more digital models that represent the basic features of the form of this initial concept<sup>28</sup>. Architects evolve this first idea and develop it further based on rational specific to every project. The models created generally utilize Bentley System’s Micro station Triforma as a modeling environment to create parametric models that are based on the definition of relationships between the parts and components of the building designed rather than absolute geometrical values of these components<sup>29</sup>. As the values governing these relationships are changed and set adhering to site and project constraints the form of the building gradually evolves. The

---

<sup>26</sup> Jenkins, David, “On Foster ... Foster On”, Prestel, 2000, p.772

<sup>27</sup> Kolarevic, Branko, Hugh Whitehead,” Architecture in the Digital Age; Design and Manufacturing; Chap7: Laws of Form”, Spon Press,2003,p.83

<sup>28</sup> Ibid ,p.85

<sup>29</sup> Jenkins, “On Foster ... Foster On”, p.779

virtue of using such a method is that it easily facilitates the exploration of the impact of changes in the geometrical characteristics of a component has on the overall form of the structure designed real time eliminating several intermediate modeling phases that would have been necessary had another approach been adapted. This undoubtedly saves a great amount of time as it allows architects to thoroughly consider and study greater possibilities and consequently form better informed decisions<sup>30</sup>.

As an integral part of Foster's philosophy, great attention is given to sustainable design, energy conservation and climatically related issues<sup>31</sup>. Digital capabilities allowed the practice to explore these concerns on a wider scope making them one of the cornerstones of the design and form generation process as they are addressed at the very early conceptual stages.

Both the role of the SMG and the capability of digital tools to encompass several aspects that contribute to the quality of the designed structure could be portrayed clearly through the conceptual development process of the City Hall in London. The initial concept behind the project was a spherical shaped building portraying a lens overlooking the river reflecting the transparency of the legal process for which the building stands as an icon<sup>32</sup>. Taking this concept as a base for their work, the SMG prepared several spherically shaped parametric models to be passed on to the architects who tweaked and morphed the form based on energy consideration to obtain a self shading structure<sup>33</sup>(Fig.5.9). Engineers from Ove Arup conducted intensive sun and energy calculation studies using the digital environment to determine the envelope's

---

<sup>30</sup> Ibid, p.779

<sup>31</sup> Foster and Partners, "Philosophy", <http://www.fosterandpartners.com/>, 11<sup>th</sup> Mar, 2006

<sup>32</sup> Ibid.

<sup>33</sup> Kolarevic, Whitehead, "Architecture in the Digital Age; Design and Manufacturing; Chap7: Laws of Form", .p.85

energy gain values (Fig 5.10). These studies which verified that the form confirmed to the architect's intent also influenced the Glazing, cladding and solar panel layout options to further maximize on energy conservation<sup>34</sup>.



Figure 5.9 Self shading form of the City Hall

Figure 5.10 Digital sun study for City Hall

Wind pressure studies was an essential part of the form definition process of the Swiss Re office building in London (Fig.5.11), where computer Fluid Dynamics (CFD) studies were conducted to test the stability of the structure and glazing relative to wind velocity as well as to investigate the efficiency of the interior passive ventilation system designed and wind behavior in relation to the surrounding exterior environment<sup>35</sup>.



Figure 5.11 Aerodynamic form of the Swiss Re HQ

Figure 5.12 Complexly curved roof form of the Gateshead Concert Hall

<sup>34</sup> Kolarevic, Whitehead, "Architecture in the Digital Age; Design and Manufacturing; Chap7: Laws of Form", p.87

<sup>35</sup> Jenkins, "On Foster ... Foster On", p.778

In another project, the Gateshead Concert Hall in UK (Fig.5.12), the parametric modeling capabilities enabled the designers to study over 100 roofing options for the form of the structure<sup>36</sup>.

The ability to seamlessly obtain physical output from digital information allows for further conceptual studies and design development as it facilitated non Cartesian geometry exploration by actually sketching on the surface of the physical models built. This method allowed for the study of the glazing scheme for the façade of the City Hall building<sup>37</sup>. The physical models obtained are also a powerful means of verifications of the accuracy of the digital model and the constructability and ease of assemblage of the different parts of the structure. In the case of the Swiss Re project the physical model played an essential role in detecting a flaw in the digital model before it was passed on to the contractor, thus eliminating the discovery of such flaws later in the construction process as the building is constructed saving both time and great costs<sup>38</sup>.

Not only was the technology used to eliminate errors during construction, it was also utilized to ease construction and reduce costs through the rationalization of the digital models. While today's technology provide the means for constructing complexly curved geometries previously rendered unbuildable, Foster and Partners' approach is to try to keep the geometry simple for ease of construction rather than engage in complex geometry exploration. This approach is evident through their rationalization phase where the digital model is rebuilt redefining all free form curvature by using specific radii and simplified geometry<sup>39</sup>. An example is the Gateshead Concert hall roofing

---

<sup>36</sup> Ibid, p.779

<sup>37</sup> Kolarevic, Whitehead, "Architecture in the Digital Age; Design and Manufacturing; Chap7: Laws of Form",, p.86

<sup>38</sup> Jenkins, "On Foster ... Foster On", p.782

<sup>39</sup> Kolarevic, Whitehead, "Architecture in the Digital Age; Design and Manufacturing; Chap7: Laws of Form",, p.89-91

structure that was rationalized to limit the No. of curves defining its form to the values of 9 radii<sup>40</sup>.

Another aspect of the rationalization process is the development of modified software that flattens curved glazing surfaces in order to enable panelizing the glazed areas with flat glass panels. This was evident in the rationalization process of the exterior cladding of the City Hall Project as well as the rationalization process of the internal glazed atrium in the same building<sup>41</sup>.

While an effort to standardize the building components' geometry in order to reduce costs by ensuring relatively easy construction and better comprehension of the forms by contractors through rationalization is evident, variation in geometrical characteristics of some of the building components is inevitable. This is where the ability to keep record of information is crucial to achieve a smooth construction process. The City Hall in London serves as a good example as barcodes and holographic targets kept track of different components having up to 1mm geometrical variations through both the fabrication and assembly phases of the construction process<sup>42</sup>. These barcodes and targets were also linked to a digital database that pinpointed their location on the façade and verified whether assembly and setting out coincided with the final digital model produced for the contractor<sup>43</sup>.

### **Bernard Franken Architecture**

Another approach to employing technology in the design process is that followed by the architect Bernard Franken. This approach utilizes the digital environment as a

---

<sup>40</sup> Jenkins, "On Foster ... Foster On", CD

<sup>41</sup> Ibid, p.782

<sup>42</sup> Kolarevic, Whitehead, "Architecture in the Digital Age; Design and Manufacturing; Chap7: Laws of Form", p.92

<sup>43</sup> Ibid,p.92

means of generating a form that communicates a certain expression conveyed by the client. Using Maya, Software generally used in the film industry, basic shapes or elements are chosen on which hypothetical digital forces relating to the context of the expression pursued are applied, deforming and morphing it through several attempts and experiments into a new form<sup>44</sup>. The three BMW Pavilions designed by Bernard Franken and ABB Architekten serve as a clear example of this approach. Using this process, a "Bubble" was conceived as a concept for the 1999 BMW hydrogen powered car exhibit at the International motor show in Frankfurt. The form was generated in Maya simulating the Merge of two water drops<sup>45</sup>. For the 2000 Geneva, Switzerland BMW exhibit the theme of hydrogen energy was again expressed through the form of a "wave" by capturing the deformation of a surface due to forces inflicted on it<sup>46</sup>. In the 2001 exhibit a different theme was expressed in the form resembling the effects of a car driving through several parallel lines portraying the Doppler Effect and named "Dynaform"<sup>47</sup>.

Once a satisfactory form is obtained, it is then referred to as the "master geometry" which is fixed and could not be altered<sup>48</sup>. However several "derivates"<sup>49</sup> generated from it based on structure, light, acoustics, and sun studies among several others are the basis of the final form which is a synthesis of several aspects of these studies combined to achieve the best perceived aesthetic among several options.

---

<sup>44</sup> Kolarevic, Branko, Bernard Franken," Architecture in the Digital Age; Design and Manufacturing; Chap9: Real As Data", Spon Press,2003,p.125

<sup>45</sup> Franken Architekten, "The Bubble", <http://www.franken-architekten.de/>, 11<sup>th</sup> Mar, 2006

<sup>46</sup> Shodek, Bechthold, Griggs, Kao, Steinberg, " Digital Design and Manufacturing", p.69

<sup>47</sup> Franken Architekten, "Dynaform", <http://www.franken-architekten.de/>, 11<sup>th</sup> Mar, 2006

<sup>48</sup> Kolarevic, Franken," Architecture in the Digital Age; Design and Manufacturing; Chap9: Real As Data",, p.128

<sup>49</sup> Ibid, p.128



Franken claims<sup>50</sup> that these forms, which are in essence based on rational force studies and reactions, are not random. The logic to which they conform could prove advantageous in the provision of structural solutions as well as dealing with the other systems within the structure. Yet he emphasizes that a challenge is posed when dealing with the structural system as physical reactions to the forces imposed on the form digitally might affect the aesthetic drastically if not dealt with creatively<sup>51</sup>. Further development of the project is supported by software such as CATIA for complex structural elements, Vector works for light studies, and pk stahl for the generation of shop drawings<sup>52</sup>.

While orthogonal drawings are an essential means of representation, Franken stresses on the role of visual animations and physical models in conveying the very complex forms to the client and also allowing the architects and designers to reconsider aspects and views which may have been overlooked initially. Due to the complexity of the forms, these models usually require specialized fabrication expertise as well as special methods of fabrication that utilize an array of CNC capabilities. The great time and effort devoted to fabricating these models eventually factors to give an insight as to how the structure could be constructed and what means of technology would aid the process.

As is the case with both Gehry and Foster, the complexity of the forms designed by Franken inevitably imposes customization of building components to a very high extent. The “Bubble”, for example, was composed of 305 different doubly curved acrylic glass panes<sup>53</sup>. These panes were heat formed into foam molds that were CNC milled.

---

<sup>50</sup> Ibid,p.131

<sup>51</sup> Ibid,p.131

<sup>52</sup> Ibid,p.132

<sup>53</sup> Franken Architekten, “The Bubble”, <http://www.franken-architekten.de/>, 11<sup>th</sup> Mar, 2006

After the panes were molded, their edges were trimmed using CNC machinery<sup>54</sup>. The structural system for this same project likewise pushes customization of parts and components to the extreme as it is composed of an orthogonal grid that is composed of aluminum sections greatly varying in shape. The 3,500 highly customized aluminum sections were fabricated from aluminum sheets that were cut using a CNC controlled plasma jet in seven different factories to accommodate pressing deadlines<sup>55</sup>. For the “Dynaform”, 30,000 individual pieces of varying length were cut using CNC plasma cutters to fabricate the skin rod connectors<sup>56</sup>. Once again the computer provided an organized database through which all the needed information for fabrication is generated, organized and dispensed to the team of designers, architects and builders accordingly allowing for a greater comprehension of the scope and requirements of the project.

### **Greg Lynn FORM**

Greg Lynn FORM’s attitude towards the incorporation of digital technology in the design process has undoubtedly established the firm as one of the most controversial practices today. Perhaps it is Lynn’s combination of a degree in Philosophy as well as a degree in Architecture that is behind his philosophical views regarding technology’s influence on architecture. His rebellious approach that rejects viewing architectural artifacts as static objects argues that such views have long been imposed due to what he refers to as “retrograde concepts of motion and time”<sup>57</sup> of which he lists

---

<sup>54</sup> Shodek, Bechthold, Griggs, Kao, Steinberg, “ Digital Design and Manufacturing”, p.72

<sup>55</sup> Kolarevic, Franken,” Architecture in the Digital Age; Design and Manufacturing; Chap9: Real As Data”, p.133

<sup>56</sup> Ibid,p.137.

<sup>57</sup> Lynn, Greg,” Aminate Form”, Princeton Architectural Press, 1999, p.13

“procession, permanence, usefulness, typology, and verticality”<sup>58</sup> as examples in his book *Animate Form*. Furthermore, Lynn claims that typical architectural animation software reinforces these views by placing the artifact in a Cartesian plane that could only be animated by a moving view or a sequence of static instances.

As a response, Lynn utilizes software that is typically used in the film industry such as Alias, Wavefont, and Softimage as environments for form generation<sup>59</sup>. His approach is based on the imposition of dynamic forces extracted from the project’s context whether from the site, the building program, circulation schemes, external environmental influences or building type among others, to be imposed on a preliminary shape in reference to time. While Lynn suggests that this methodology enables him to “use motion for the generation of architectural projects dynamically”<sup>60</sup>, he also states that it is a process that highly depends on the ability of the software to support modeling of surfaces that bend, flex and mutate in response to these forces and that this process generally has “undecidable” outcome when it comes to form. Needless to say, this approach depends heavily on the digital capabilities of the software as Lynn clearly stated to *Lingua Franca* in an interview for *Metropolis Magazine*, “If it comes down to it, I would have to give the software 51 percent of the credit for the design of my buildings,”<sup>61</sup> he further expressed that he often feels at the mercy of his design tools. It is this voluntary surrender to technology that is perhaps the source of controversy surrounding the practice, for even those architects at the forefront of digital exploration

---

<sup>58</sup> Ibid, p.13

<sup>59</sup> Greg Lynn FORM, Links, <http://www.glform.com/>, 12<sup>th</sup> Mar, 2006

<sup>60</sup> Lynn, “*Animate Form*”, p.13

<sup>61</sup> *Wired Magazine*, Nov 2004 issue, “Frank Gehry For the Rest of Us”, <http://www.wired.com/wired/archive/12.11/gehry.html>, 12<sup>th</sup> Mar, 2006

such as Gerhy are reluctant to indulge in giving total control of the design process especially when it comes to the early conceptual phases.

Another source of controversy is undoubtedly the conversion of the blobular architecture resulting from this process into built realities. The Blob, an acronym for “Binary Large Objects”, is one of 10 terms created by Lynn to help establish a rationale behind the complex digital forms resulting from his design process. These terms are bleb, blob, fold, flower, strand, shred, skin, teeth, branch, and lattice. The complexity of the forms generated extends to their fabrication which is intensively based on the use of CNC capabilities both those in-house, and those accessed through collaboration efforts with the movie making industry in Hollywood, the aeronautical industry, the automotive industry and those available at design schools in the country. Though these technologies play a great role in the production of representational physical models, their role in translating the digital forms generated into physical realities is still vague as the majority of Greg Lynn’s work remains unbuilt and is thus limited to theoretical and digital form exploration.

The Hydrogen Pavilion project (Fig.5.13), a collaborative effort with Michael McInturf Architects and Martain Treberspurg demonstrates the design philosophy and process adapted at Greg Lynn FORM. The project was a “multi-functional visitor and demonstration center for the display of new hydrogen, solar and low energy technologies located at the public entry to the Austrian National Oil Company in Austria”<sup>62</sup>. Utilizing a vector based animation software and a triangulated shape derived from the company’s logo, the designers started by projecting the depth of the initial shape and used it as a skeletal base wrapped in surfaces on which solar simulations were performed to determine the orientation of the projections and the solar panels. The role of motion in the design development process is evident as the movement of passing automobiles along the highway bounding the site to the north, was used as a force that

---

<sup>62</sup> Greg Lynn FORM, H2 house, <http://www.glform.com/>, 12<sup>th</sup> Mar, 2006

sweeping the façade and defining the dynamic form of the building. A Physical model representing this form was built using laser stereolithography techniques that depict the translucent nature of the fabric forming the skin of the structure. Like majority of Lynn's projects, the Hydrogen Pavilion was commissioned in 1996 however was canceled in 1999 before the start of the construction phase.

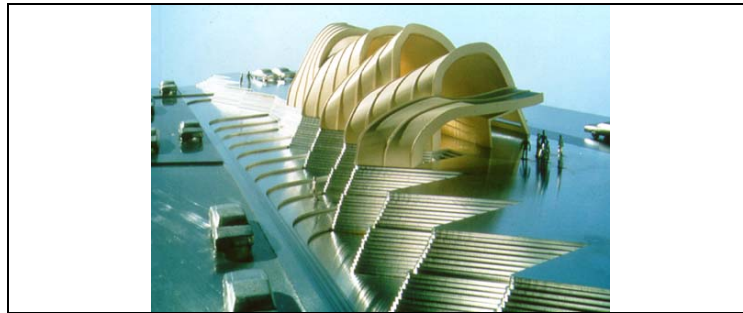

Figure 5.13 The Hydrogen Pavilion

### **SHoP Architects**

SHoP is one of the unique architecture firms practicing today. Not only is it so because of its young age or because of the fact that none of its five founders majored in architecture, but mainly because of its practice philosophy and the way in which technology integrates within this philosophy.

The reason why SHoP's philosophy sets it apart from the majority of architecture practices today is how it embraces the business and financial aspect of the profession as a major player and decision making factor hence following similar practice strategies to those adapted in industrial design. While the norm in the architectural profession is to evade dealing with issues related to site restrictions, choice of materials, structural and systems realities and the client's budget constraints until after the conceptual basis and the form is determined; SHoP deals simultaneously with these restrictions as it develops the conceptual basis, allowing such factors to mold the form of the project. The computer's role within this setting is to provide the environment

through which project constraints are recorded and facilitate the interaction between such information and the architect's ideas in order to generate the final form. Pasquarelli described the process in May 2001 to Metropolis Magazine as he said:

*“As information is gathered from the contractors, the clients and our design idea, we can feed that into the model, then the form moves and adapts, but the design keeps its integrity....We really feel that our buildings improve as more restrictions are placed on them.”*<sup>63</sup>

Software used in this process includes Rhino, CATIA and Gehry Technologies' Digital Project<sup>64</sup>, as well as other software used in the film industry such as Maya<sup>65</sup>. While SHoP argues that this technology enables it to absorb more information in the design process<sup>66</sup>, they also stress that it is only part of the process that includes the generation of physical models. Pasquarelli again expresses:

*“The computer will not design for you, you work it in the computer, pull it out, work it in model, work it in construction techniques, work it visually, and then its back to the computer. For us it's all about this cycle.”*<sup>67</sup>

The physical models do not only bring a sense of tacitly into the process but also provides grounds for experimentation with construction techniques and the feasibility of such techniques that inevitably plays a role in form generation.

SHoP's projects are a manifestation of this design methodology. The façade of the Fashion Institute of technology is an expression of human sexuality; however the

---

<sup>63</sup> Metropolis Magazine, “SHoP Talk”, [http://www.metropolismag.com/html/content\\_0501/shp/index.html](http://www.metropolismag.com/html/content_0501/shp/index.html), 12<sup>th</sup> Mar, 2006

<sup>64</sup> Architectural Record, “ Hangil Book House”, <http://archrecord.construction.com/projects/portfolio/archives/0502hangil.asp>, 12<sup>th</sup> Mar, 2006

<sup>65</sup> Lecture given by Gregg Pasquarelli at The School of Architecture in Mississippi State University, 5<sup>th</sup> Oct, 2005

<sup>66</sup> Metropolis Magazine, “SHoP Talk”, [http://www.metropolismag.com/html/content\\_0501/shp/index.html](http://www.metropolismag.com/html/content_0501/shp/index.html), 12<sup>th</sup> Mar, 2006

<sup>67</sup> Ibid.

curves of the form are dictated by site conditions, circulation and flexibility considerations, exhibition needs, and lighting requirements <sup>68</sup>(Fig.5.14 & 5.15).

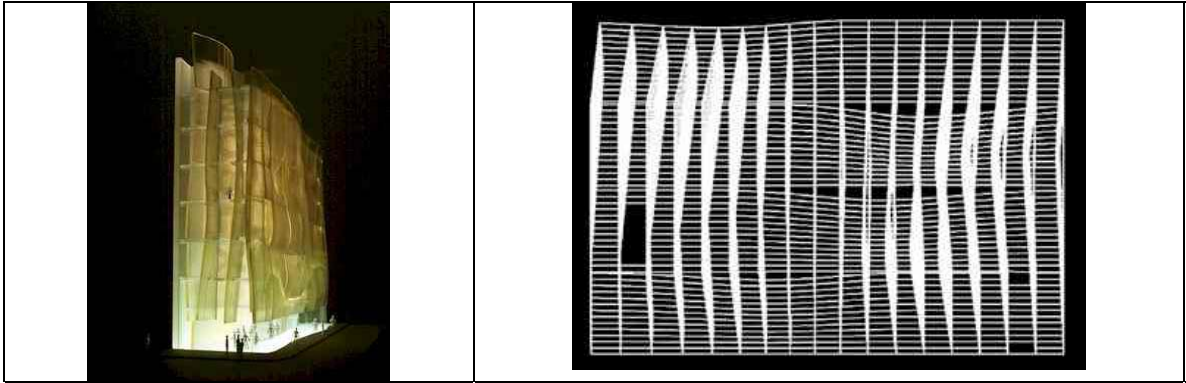

Figure 5.14 Fashion Institute of Technology

Figure 5.15 Façade study of the Fashion Institute of Technology

In another project, The Carousel at Greenport, Long island, and information concerning site restrictions in addition to a study of horses in motion, the Doppler Effect, wave analysis and the client's budgetary concerns were determining factors in the choice of the type and size of glazing panels and hence the size of doors used to enclose the façade<sup>69</sup> (Fig 5.16). The physical model, while playing an important role in the design development process, played another essential role in comprehending the construction requirements and testing the assemblage process. Such information was used to further develop the form in order to sensibly influence and ease construction or to highlight any challenges expected during fabrication and construction before they appear on the construction site<sup>70</sup> (Fig.5.17).

<sup>68</sup> SHoP Architects, "Projects: Fashion Institute of Technology", <http://www.shoparc.com/>, 12<sup>th</sup> Mar, 2006

<sup>69</sup> Lecture given by Gregg Pasquarelli at The School of Architecture in Mississippi State University, 5<sup>th</sup> Oct, 2005

<sup>70</sup> Metropolis Magazine, "SHoP Talk", [http://www.metropolismag.com/html/content\\_0501/shp/index.html](http://www.metropolismag.com/html/content_0501/shp/index.html), 12<sup>th</sup> Mar, 2006

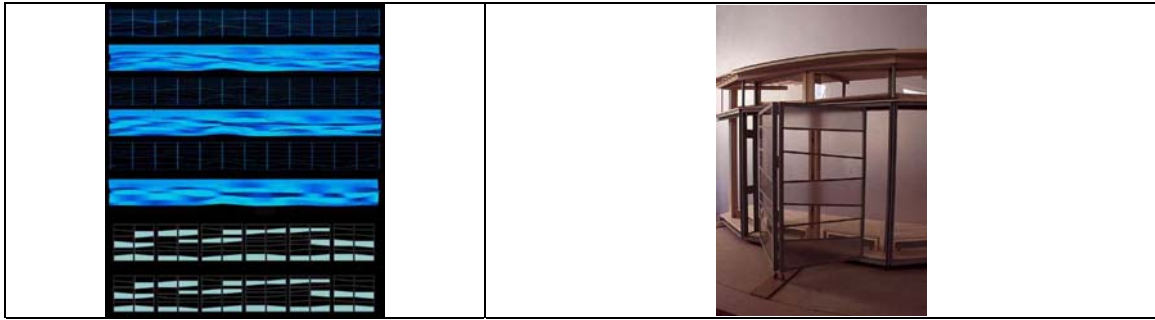

Figure 5.16 Wave analysis study

Figure 5.17 Physical model of the Carousel at Greenport

The Camera Obscura project is probably the one most demonstrating the firm's strategy with regards to the integration of technologies in the design and fabrication process. Built for only \$185,000<sup>71</sup>, the project was the first that is 100% digitally designed and fabricated following the kit of parts approach that is typically followed in industrial design. The structure is comprised of 750 wood, steel and aluminum parts each custom designed and CNC fabricated. Wooden framework was milled in one morning in Brooklyn while aluminum and steel components were cut using CNC plasma cutters and partially assembled in Long Island<sup>72</sup>. The parts arrived on site protected in bubble wrap where they were assembled in no more than 6 weeks<sup>73</sup> (Fig. 5.18 & 5.19).

---

<sup>71</sup>Wired Magazine, Nov 2004 issue, "Frank Gehry For the Rest of Us", <http://www.wired.com/wired/archive/12.11/gehry.html>, 12<sup>th</sup> Mar, 2006

<sup>72</sup> Ibid

<sup>73</sup> Ibid



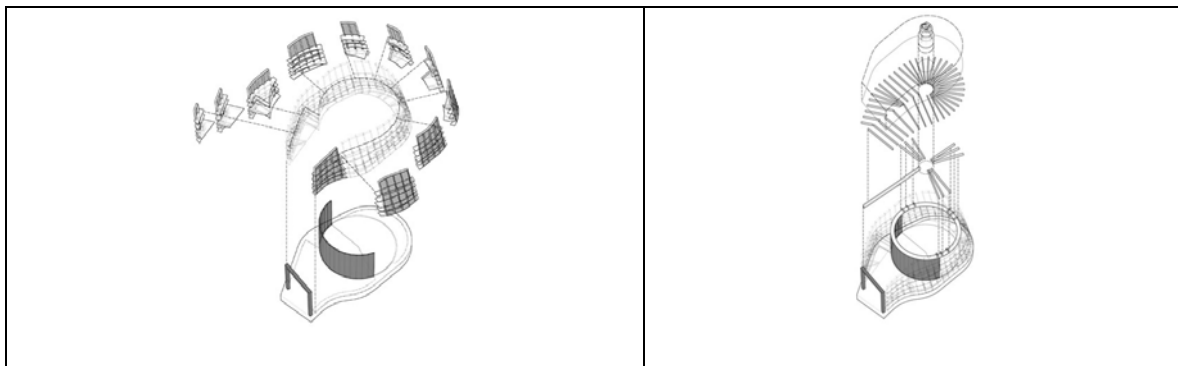

Figure 5.18 Wall components of the Camera Obscura

Figure 5.19 Roof components of the Camera Obscura

This approach of utilizing technology in a way that takes into account the realities of fabrication during the design development process to provide more affordable customized architecture where the form is a product of all the project's constraints is what characterizes Shop's practice. Pasquarelli explains that "The computer has been a tool that's helped us to develop a new model. It's not about the form."<sup>74</sup>

### **Architecture, Technology, and Houses**

Due to the high costs associated with the technologies that have lately transformed the architectural practice, their use and application were generally restricted to high end multi million dollar budget projects and monuments where such costs may be justified. Houses as a project typology did not benefit much from the application of these digital capabilities. However, with this in mind, it is worth mentioning that there are a number of high end highly customized residential projects that engage the use of these technologies despite its high cost. Nevertheless many of these projects remain unbuilt as they were considered unfeasible even for the highly affluent clientele.

At the top of this list sits the Lewis Residence (Fig.5.20) designed by Gehry and Philip Johnson. The project followed the Design process adapted at Gehry & associates

<sup>74</sup> Metropolis Magazine, May 2001 issue, "SHoP Talk", [http://www.metropolismag.com/html/content\\_0501/shp/index.html](http://www.metropolismag.com/html/content_0501/shp/index.html), 12<sup>th</sup> Mar, 2006

where physical models inspired by Gehry's sketches are digitized to transform these forms to digital data that could be rationalized using digital capabilities. The size of the project was one eighth the size of the Bilbao museum and had an estimated cost of 80 million dollars, only 20 million short of the construction cost of the museum<sup>75</sup>. This outrageous cost could be comprehended when one studies the high level of variation in the projects' parts. Each different component is expressed through different material combinations and unique forms that have no relation to the other parts except perhaps in their complexly curved nature (Fig.5.21). Though the Lewis residence was abandoned after 6 years of design development (1989-1995), Gehry considers the project a turning point in the firm's development as it served as grounds for experimentation and exploration. In addition to that, individual components of the project lent themselves to serve as focal elements in subsequent projects, such as the use of the horse head shaped gallery to serve as a form for the roof of the conference room, the focal point in the DG Bank project in Germany<sup>76</sup>.



Figure 5.20 Physical model of the Lewis Residence

---

<sup>75</sup> Gehry Partners, *Gehry Talks*, architecture+ Process, Universe Publishing, 2002, P96

<sup>76</sup> Lindsey, "Digital Gehry; Material Resistance/ Digital Construction", p.80

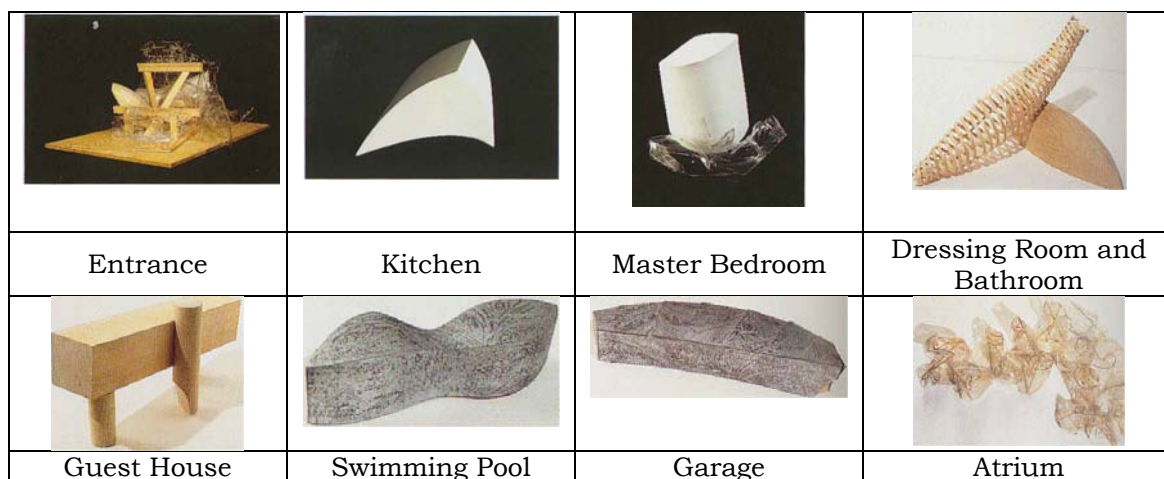

Figure 5.21 Different forms and shapes for different components of the Lewis Residence

The Embryological House, designed by Greg Lynn as part of a theoretical and digital study between 1998 and 1999 sponsored by a research grant from the International Design Forum and a contribution from the Wexner Center for the Arts in addition to the Academic support and digital capabilities provided by UCLA's Department of Architecture in Los Angeles. The study focused on the use of digital technologies to design a mass customizable domestic space taking into account issues of variation, flexible manufacturing, assembly, and brand identity while greatly stressing on the beauty of forms, and the aesthetic of undulating surfaces and vivid colors.

The design process utilized a digital system of supporting parametric control of geometrical limits for form generation. These limits were extracted from possible lifestyle contingencies, lifestyle restrictions, climate, construction methods, available materials, spatial effects and functional needs as well as aesthetic considerations<sup>77</sup>. This approach allows the user whether client or architect to set these limits from which the digital environment generates endless possible of form variations that ensures that no two variations are ever identical (Fig.5.22). The embryo was used as a metaphor for the process

<sup>77</sup> Greg Lynn FORM, Embryological house, <http://www.glform.com/>, 12<sup>th</sup> Mar, 2006

of growth that the structure goes through as it is customized from the initial basic “seed” in the digital environment to a more mature structure by fixing the variables to suit situations and preferences and allowing the parametric computational capabilities to generate forms accordingly reflecting a certain character. According to Lynn this approach is a welcomed departure from the Modernist mechanical Kit-of-parts approach providing a more vital and evolving aesthetic.

Site requirements were set at a minimum of 100 foot diameter clear area with no more than a 30° slope and a 14 month period was estimated as the typical duration of design, production, shipping and assembly. However as the project was a pure theoretical exploration, it did not go beyond the fabrication of to scale physical prototypes exhibiting 6 possible instances of the wide range of possibilities. The largest prototype, which was donated by CNC Dynamix of Switzerland, was a 30% scaled model carved from a block of foam using a computer-controlled robotic mill (Fig.5.23).

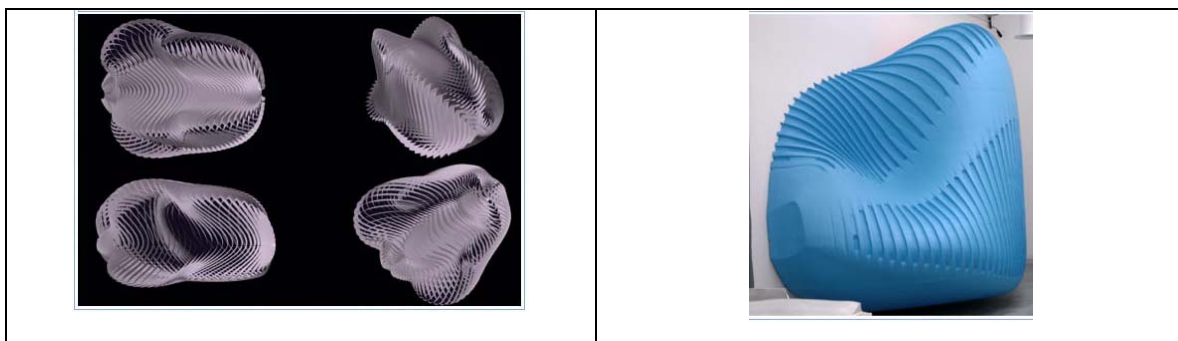

Figure 5.22 Form variations of the Embryological House

Figure 5.23 Physical model donated by CNC Dynamix

A rare example of a completed residential project that employed digital technologies in both design and fabrication phases is the Turbulence House designed by architect Steven Holl. The project that is situated on a windy desert mesa is designed to serve as a house for the couple Richard Tuttle, an artist and poet Mei-mei Berssenburgs. The couple expressed their desire to build a structure contrasting to the

two adobe buildings that they resided, a structure that would be manufactured like an air stream mobile home<sup>78</sup>.

Both the clients' desires and site characteristics provided inspiration for Holl who envisioned the house as a tip of an iceberg sitting atop the windy mesa with a central opening shaped as if created by the winds passing through it and a sloped roof oriented south to accommodate photovoltaic panels<sup>79</sup>. The design process was very similar to that followed by Gehry as it started by a watercolor sketch depicting Holl's idea<sup>80</sup>. However, unlike Gehry the sketch was directly converted to a 3D wireframe digital model using 3D parametric software very much like that used by Foster, Grimshaw and Lynn. This parametric environment not only supported the design development stage but also helped define the details of the aluminum skin panels and ribbing the two to form one enclosure. Once the design stage was completed a physical model was prepared and passed on to the metal fabricator, the A. Zahnar Company, which converted the information from this physical model once again to digital information using Pro/Engineer as a digital environment. Parametric logic again helped define the shapes of the structural ribbing members as well as the shapes of the 31 unique aluminum panels needed for fabrication. The panels were fabricated off-site, and then shipped to the site where they were assembled through bolting them together in six days (Fig 5.24). The total area of the project was 900 sq. ft and the total cost of the project was approximately \$100,000.

---

<sup>78</sup> Architectural Record, "Turbulence House", Feb 20<sup>th</sup> 06  
<http://archrecord.construction.com/projects/residential/archives/0504RHf-1.asp>

<sup>79</sup> Steven Holl Architects, "Turbulence House" Feb 20<sup>th</sup> 06 ,<http://www.stevenholl.com/>

<sup>80</sup> Architectural Record, "Turbulence House", Feb 20<sup>th</sup> 06  
<http://archrecord.construction.com/projects/residential/archives/0504RHf-1.asp>

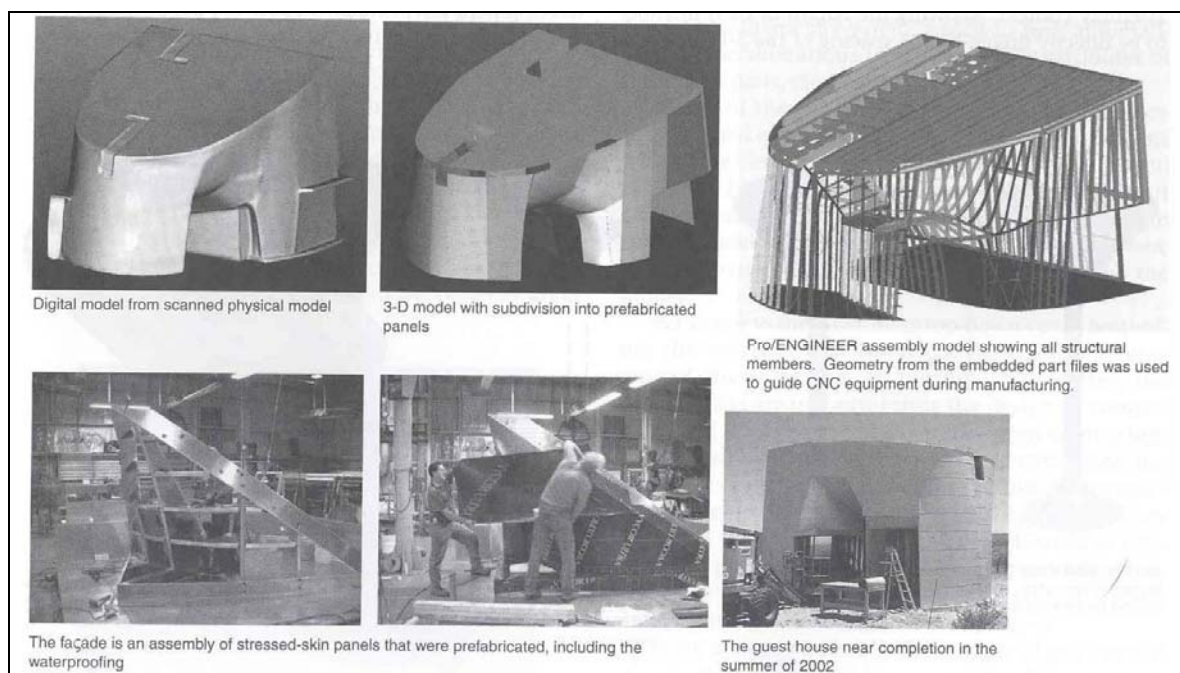

Figure 5.24 Fabrication and assembly of the Turbulence House

### Conclusion

There is no doubt that technology has transformed the architectural profession. The emerging fluid curvaceous forms stand as a testimony to both the potential of digital tools and the creativity of architects in engaging these tools in the architectural design and construction process.

As architects realized the potential of digital applications, different approaches to their integration in the architectural design process emerged based on different practice philosophies and proprieties<sup>81</sup> (Fig 5.25).

<sup>81</sup> Barrow, "Cybernetic Architecture; Process and Form The Impact of information Technology" p. 245

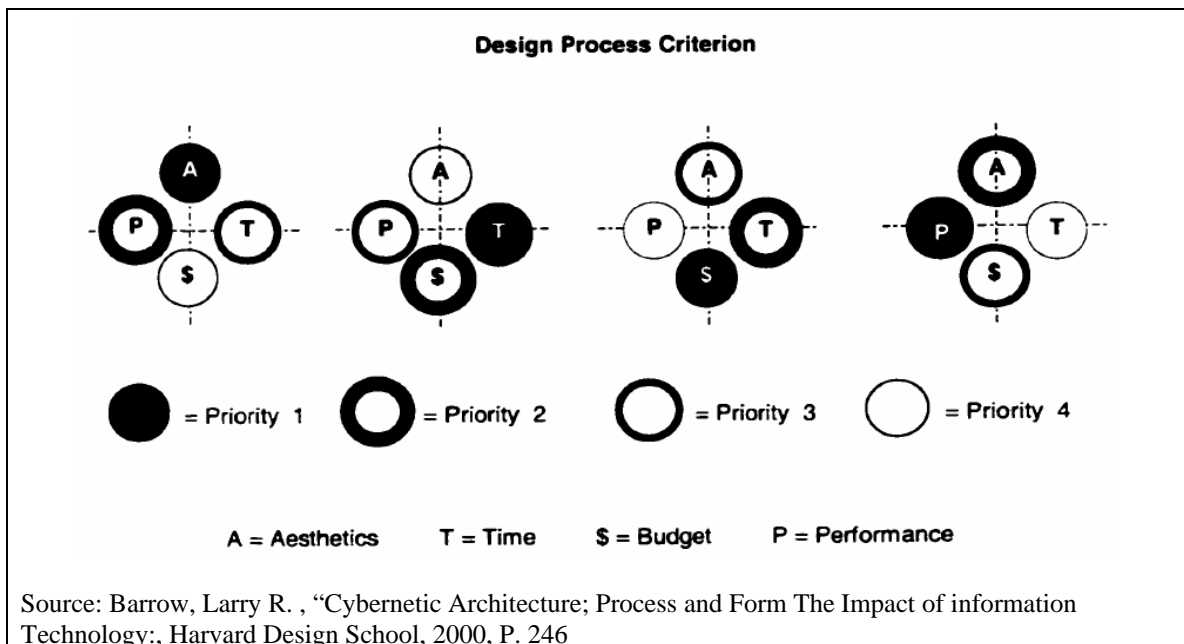

Figure 5.25 Different architectural design approaches based on different priorities and philosophies

Although these emerging approaches to engaging digital application in the design and construction process varied both in terms of the software applications used and the underlying philosophy behind its use, they all shared a number of common factors.

1. Whether used as a form generating tool or not, computer applications facilitated the design and fabrication of extremely complex curved forms. Attitudes inclined towards engaging technology in the form generating process are increasingly engaging parametric logic in this area as they realize the virtues of its use in enhancing their design process. The Communication of construction information that accurately define complex forms, previously a massive obstacle to their construction, ceased to be so with the use of both software environments that support construction applications and CNC fabrication tools.

This technology enabled the architect to be, as Gehry articulated, "closer to the craft" thereby regaining control as the leader of the profession and the master builder in the 21<sup>st</sup> Century. While prior to the use of these digital capabilities such control was maintained by simplifying the geometry of the built artifact, eliminating complexity in details, utilizing modularity and repetition of components to facilitate construction; architects today are free to pursue complex details and variety in building components' shapes and characteristics to the point where every component is a distinctive and unique part without compromising control over the process. Ironically, digital environments that opened the door to such variation are those used to support modularity and mass production in industrial production.

2. The use of CAE applications emerged concurrent to the use of CAD/CAM applications. However, their role was restricted to informing the form generation process at subsequent stages in design development and usually results in modifying and tweaking already set forms to enhance performance rather than driving the form based on performance considerations even when incorporated in the process in practices very much engaged in performance based architectural design.

There is no doubt that this common factor shared by architects in their utilization of technology, is their quest to bring to reality unique forms through pushing to the extreme technology's ability to support variation of parts and components. While such a strategy may be justified when used for huge public projects, its feasibility in terms of time and cost for the design and construction of the average residence is questionable. However as architects continue to stretch the possibilities; extreme variation and complexity of one-off custom residences characterize the few housing



projects that engage these digital capabilities, many of which remain paper and digital bound ideas.

Within this setting emerges the house as an architectural typology that was once deemed by Modernist views as the architectural commodity fit for mass production. As the architectural profession today is mesmerized by further possibilities for variation and customization promised by technology, mass production principles are substituted with mass customization ideologies. Yet architects' definition of mass customization itself varies from that based on modularity and interchangeability of parts as used by other industries and promotes variety and extreme differentiation of components arguing that digital capabilities today make it as convenient to design and build 100 different parts as it is to design and build 100 identical ones. As architects continue their exploration in the field, a favorable balance between utilization of technology to improve performance and its use to achieved mass customization is yet to be reached, Perhaps the reason behind this is best articulated by Dr. William McWhorden, an aerospace engineer and the director of the Aerospace Engineering Department at Mississippi State University, when he said in a conversation with Dr. Larry Barrow, an architect and the Director of the Graduate Program at the College of Architecture, Art, and Design at the same university, that "architects are encumbered by the need to be original".

**Key Points**

- The Sydney Opera House and the Kansai Airport are two projects demonstrating the early applications of CAD in architecture. The utilization of CAD was necessary to help cope with the complexities of the rationalization and construction of curved geometries. Technology did not play a significant role if any in the early conceptual and form generation stages at that point.
- Frank Gehry, a pioneer in utilizing digital technologies that are used in industry for the realization of complex double curved geometries. Yet his approach was similar to that used in the preceding earlier CAD application in architecture as it restricted the use of these technologies for the pre construction and construction phases of the design process excluding its use from the form the conceptual and form generation stages.
- Gehry's approach in using technology to make possible the construction of complex double curved forms depends on the ability of the digital environments and CAD/CAM applications to generate the part geometric variations seamlessly and keep track of these component variations in an organized manner during construction.
- Norman Foster's approach to the incorporation of digital capabilities in practice relies on the use of the digital parametric capabilities for form generation. This approach also utilized CAE capabilities to produce analytical studies that influence the form generation process. While Foster strives to utilize technology in order to streamline construction, the nature of the forms generated usually demand a level of customization of building components. Digital means help generate and keep track of these components to ease the construction process.
- Bernard Franken uses computer applications intensively at the preliminary stages of the design development process as a means of form generation based on the application of hypothetical forces extracted from the context and image of

the project to morph basic shapes in order to generate the final form. This process also relies on CAD/CAM capabilities to generate and keep record of the highly customized structural as well as skin components.

- Greg Lynn, a strong advocate of using technology extensively to enhance the design process from the earlier conceptual stages to the final construction of the artifact. Lynn's philosophy that rejects the inert architecture of today proposes the use of animation oriented software to capture an sense of motion in buildings he designs totally depending on the software to generate the form and build the final artifact. One characteristic of this approach is that the process is unpredictable and the forms generated are usually extremely complex requiring extreme customization of parts and components for construction. Therefore, construction of these forms relies heavily on the use of digital applications and CNC capabilities to record the information defining the various parts needed as well as fabrication of these parts.
- SHoP architects introduce another approach in incorporating digital means in architectural practice borrowing some of the principals of industrial and product design. This strategy incorporates the use the digital environment to shape the form of the final structure based on the site, budget and performance constraints among many others. This approach extends to include the design process where SHoP works to reduce on site work by maximizing factory prefabrication and easing onsite assemblage of the prefabricated parts. While this approach reduces costs greatly it still depends to a great level on the use of technology to generate and fabricate these customized components.
- As architects became familiar with the capabilities of technologies and their possible applications in the profession their approaches to their utilization was formed by their knowledge and their interpretation of their potentials in light of their design philosophies and strategies.

- Computer applications facilitated the design and fabrication of extremely complex curved forms. The Communication of construction information that accurately define complex forms, previously a massive obstacle to their construction, seized to be so with the use of both software environments that support construction applications and CNC fabrication tools enabling the architect to assume the role of the mater builder which he though he had forfeited as the complexity and size of projects increased.
- Architects today are free to pursue complex details and variety in building components' shapes and characteristics to the point where every component is a distinctive and unique part without compromising control over the process. This is done through the use of technologies used to facilitate mass production of similar parts and components in the industry.
- Attitudes inclined towards engaging technology in the form generating process are increasingly engaging parametric logic in this area as they realize the virtues of its use in enhancing their design process which is another characteristic of industrial design.
- The use of CAE applications was restricted to informing the form generation process at subsequent stages in the design development and usually results in modifying and tweaking already set forms to perform better rather than driving the form based on performance considerations even when incorporated in the process of practices very much engaged in performance based architectural design.
- Due to the high cost of the technologies used in architecture they are not usually utilized in the design process of residences. However in the few exceptions that emerged, this design process follows the same design

methodology used for larger projects where the high cost may be justified. Thus many of these housing projects remain unrealized proposals or restricted to the elitists.

- As the architectural profession today is mesmerized by further possibilities for variation and customization promised by technology, mass production principles are substituted with mass customization ideologies. This definition of mass customization however varies from that based on modularity and interchangeability of parts as used by other industries and promotes variety and extreme differentiation of components. As architects continue their exploration in the field, a favorable balance between mass production and mass customization, especially when it comes to housing as a building typology which was once deemed by modernist views as the architectural commodity fit for mass production; waits to be achieved, though so far it seems, that “architects are encumbered by the need to be original”.

CHAPTER VI  
TECHNOLOGY AND INDUSTRY

**Introduction**

As is well known, one of the many changes associated with industrialization is the shift from the total dependence on craftsmanship for the production of custom one off artifacts to the employment of machinery for the manufacture of everyday commodities in large quantities. This transformation does not only reflect the technological developments, but is also a consequence of urbanization. As increasing percentages of the demographic moved from rural to urban areas and as cities grew at an accelerating rate, so did the demand for commodities and consequently so did the number of manufacturers aiming to profit from the situation. Competition was fierce as each manufacturer aimed to anticipate the public's needs, produce commodities of a high quality, at a high volume yet a low price and to achieve all that at a shorter timeframe than other competitors in the business.

Ford's model T, a vehicle of undisputed quality at the time, could perhaps be the perfect example of the successful achievement of such a goal. Ford's production strategy, utilizing the assembly line, resulted in reducing the price of the automobile to the third<sup>1</sup> and increasing productivity to a Model T per second<sup>2</sup>. Yet even with the successful Model T there was one substantial problem, as Ford famously said, "You can

---

<sup>1</sup> Morris, Woods, "Housing Crisis and Response: The place of mobile homes in American Life" p.5

<sup>2</sup> Ford Motor Company, "The Rouge, Output", 26<sup>th</sup> Mar,2006,  
<http://www.ford.com/en/heritage/centennial/default.htm>

buy it in any color, as long as it's black.”<sup>3</sup> As soon as markets were saturated with the mass produced identical commodities, the consumer was compelled to not only to satisfy a need but in addition to that, search for the commodity that provided a level of freedom of choice and a capacity for individual expression through variation. New challenges rose for producers; to design and manufacture a variation of similar products that would satisfy the demands of consumers, to maintain the prices of these variations at a range comparable to identical products previously produced, and to do so at a very short timeframe not only to beat the competitors to the market but to anticipate the changes of the fickle consumer taste. Inevitably, to achieve successful diversity in production increases the complexity of the process especially with the emergence of new technologies that promise great rewards only if appropriately integrated within the process. Industrial design, deals with the complexities of the design and production of commodities and with the integration of technological developments within this process.

### **The Industrial Design Process**

Like in architectural design, the industrial design process is one that depends on drawing expertise from several fields and disciplines that include marketing experts, designers, engineers and manufacturers depending on the products designed. The details of this design process inevitably varies with the specialties of the collaborating members, the type of products designed as well as the image and brand endorsed by the producer, however there are major set principles that are universally followed. The following is a simplified overview of these major guidelines.

While in architectural design the requirements and guidelines for the project are specified by the client; usually the owner or the user, in industrial design these guidelines are presented by the marketing department of the producing company

---

<sup>3</sup> Ford Motor Company, Ford Corporate Citizenship Report 2003-2004, “The Paint Shop”, 26<sup>th</sup> Mar,2006, <http://www.ford.com/en/company/about/corporateCitizenship/report/articlesPaintOverview.htm>

following intensive market research, target consumer studies and feasibility analysis. This research sets several parameters among which are perhaps the desired function, image, and the unit cost of the product. These set parameters are later passed on to designers and engineers who work to satisfy the project guidelines by establishing a form and resolving the technical requirements. Following that the proposal is passed on to the manufacturers who facilitate the economic and fast fabrication of the previously designed product through the specification of the most feasible manufacturing technologies and processes. This process is systematic, serial and iterative, cycling back and forth between the three main phases in order to redesign and rectify whenever necessary modifications at subsequent design stages that contradict with parameters set at earlier stages. The final design is reached after several iterations, usually 10 to 15<sup>4</sup>.

On one hand this serial design process helps control an inevitably complex process and organize the flow of great amounts of information, yet on the other hand, it tends to lack flexibility as it locks in decisions early in the process without referring to expertise at subsequent stages, thus constraining decisions at these stages and prohibiting engineers and manufacturers from sharing their input earlier in the process where the entire picture of the design problem is clearer and their contribution would be of a more influential effect. Furthermore, the highly iterative nature of this serial approach tends to be time consuming due to the lack of collaboration between the designers, engineers and manufacturers as their knowledge of the hierarchy and intent of the decisions made previously is vague therefore leaving them clueless as to how to best approach the design problem. Due to this, the serial design process is gradually being abandoned in favor of a more integrative approach where input from collaborators at these later phases is presented upfront undoubtedly improving the quality of the final design,

---

<sup>4</sup> Erhorn, Craig, John Stark, "Competing By Design; Creating Value and Market Advantage in New Product Development", Oliver Wright Publications, 1994, P.110



easing the engineering and manufacturing process and reducing the design time considerably as it reduces the iterations necessary to 3 to 5. Several terms are used to refer to this design process. Some of these commonly used terms are simultaneous engineering, concurrent engineering, integrated product and process design<sup>5</sup>.

Early input from various collaborators in the process has another important advantage as it helps the design team specify which of the myriad of available and emerging design, engineering and manufacturing technologies is most suitable to be used in the process. Generally, the early conceptual stages of the design process depend on freehand sketches rather than digital technologies to depict the pursued initial form and image of the product. These sketches are later dimensioned utilizing CAD applications in order to build the preliminary study models. The preliminary models are usually built manually and are often made using foam, plaster wood or clay. The intent of the preliminary models is to capture the form of the product designed. As the design progresses detailed models built manually portray the form in addition to the color, texture, mechanisms and weight of the product. At subsequent stages, more detailed models may be built utilizing rapid Prototyping techniques that include CNC capabilities<sup>6</sup>.

Incorporation of digital technologies in the process is more evident in the following engineering and manufacturing phases. Following the initial conceptual and preliminary form development stages, digital applications with parametric modeling capabilities are increasingly playing an important role in reducing product development a time as well as reducing development costs<sup>7</sup>. Other digital applications are mainly oriented towards optimizing the manufacturing process. Such applications are many

---

<sup>5</sup> Ettl, John E., Henry W. Stoll, "Managing The Design-Manufacturing Process" McGraw-Hill, Inc., 1990, P. 87

<sup>6</sup> Erhorn, Stark, "Competing By Design; Creating Value and Market Advantage in New Product Development", P.125

and include, as examples, (CAPP) computer aided process planning, (CASE) computer aided software engineering ,(EDM) engineering Data management, (KBS) knowledge based systems, (CIM) Computer-integrated manufacturing in addition to CAD, CAM and CAE applications<sup>8</sup>. Nevertheless, while digital applications specifically oriented for industrial design are countless, choices as to whether or not to incorporate their use in the process in addition to the specific applications and the methodology and intent governing their use depends on the design approach followed throughout the process. These approaches, commonly known as design for manufacturing (DFM) approaches are usually specified by the design team beforehand depending on the producer's marketing strategy as well as the function and purpose of the products designed that stress aspects in which the utilization of such digital capabilities is most feasible. According to (Ettlie & Stoll 1990) some of these design strategies or approaches are<sup>9</sup>:

*a. Axiomatic design Approach:*

Based on following two main established axioms which are:

1. Parts should maintain independent functional requirements.
2. And have the least information content.

*b. The Eliminate, Simplify, Standardize where possible approach:*

Focuses on:

1. Reducing the number of parts to the minimum
2. Simplifying the design to ensure ease of fabrication, handling and servicing.
3. Promoting standardization of parts which facilitates ease of interchangeability, interoperability, simplified interfaces, effective linkage of parts and functions as well as ensures availability of components.

*c. Standardization and Rationalization Approach:*

---

<sup>8</sup> Ibid, P.245

<sup>9</sup> Ettlie, Stoll, “ Managing The Design-Manufacturing Process” , p. 94

Seeks to eliminate complexity and controls proliferation of information throughout the manufacturing process by:

1. Standardization which aims to reducing the number of operations used to fabricate an existing product to the minimum.
2. Rationalization which enables the identification of the fewest operations necessary to fabricate a future design or product.

*d. Process Driven Design approach:*

To design a product to utilize a specified set of manufacturing operations deemed as the most suitable processes in terms of feasibility.

*e. Design for quality approach:*

To establish set parameters for the standardized parts in order to reduce variability and reduce the variability of hard to control factors.

*f. Design for change approach:*

Reduce capital investment and time necessary for the design of product in anticipation of inevitable change.

*G. Design for flexible manufacture approach:*

This approach focuses on the design for the fabrication of a family of parts regardless of the sequence, and quantity to maintain the ability to cater for future customer orders by maintaining the ability to rapidly make changes to existing products.

*H. Design for analysis approach:*

Engages the utilization of easy to use and understand design analysis tools.

*I. Design for assembly:*

This approach focuses on the reduction of the cost of assemblage by minimizing the number of parts within the designed products.

*J. DfX approach:*

Ensures that the parts and products designed meet the requirements in order to be manufactured using a specific fabrication process.

While these approaches may differ, they all share common basis as each stresses out the necessity to simplify and standardize the product designed and the process used in order to take advantage of the economies of scale as well as the associated increase in quality and productivity that are inherent with mass production, not to mention the reduction of possibility of errors once the learning curve is overcome and due to high levels of standardization and repetitive production of parts.

**The Role of Modularity in Industrial Design**

For the design of extensively complex products comprised of several complex systems such as the case in aerospace and automotive industry, the amount of information necessary to manufacture these products remains massive regardless of the efforts simplify or reduce variables. An average sized car, for example, is composed of around 4,000 parts while a Boeing 777 is comprised of more than 1,000,000 and ships may require millions of parts<sup>10</sup>. In these cases another approach is followed to control high levels of complexity which involves breaking up the product into several manageable chunks. These chunks are further divided into smaller parts better referred to as modules. A module is “a unit whose structural elements are powerfully connected among themselves and relatively weakly connected to elements in other units.”<sup>11</sup>

In addition to simplifying the architecture of the product, the advantages of this approach include the ability to fabricate the smaller modules in any geographical location which proves to be more feasible depending on political situations, exchange rates, cost of labor and material, and the engineering and manufacturing ability of the

---

<sup>10</sup> Kieran, Stephan, James Timberlake, “ Refabricating Architecture”, McGraw-Hill Companies, 2004, P.69

<sup>11</sup> Baldwin, Carliss Y., Clark, Kim B. ,“Design Rules“,MIT Press, 1999. P.63

supplier. In this manner, modules are fabricated simultaneously in locations far from assembly sites eliminating clutter at assembly, greatly reducing the time required for production and increasing the quality of the components as each manufacturer is specialized in producing certain parts. The smaller modules are shipped to the assembly sites or factories, where the bigger product chunks are assembled indoors eluding weather interruptions and facilitating ergonomic positioning of these bigger parts as workers nest the smaller modules within them before they are rotated and positioned in place to form the finished product<sup>12</sup>.

To control the large number of parts flowing through the process, parts are tagged with bar codes that record all the information related to a particular part such as fabrication information, and delivery and positioning details. Communication between the designers and engineers on one end and module manufacturers on the other is carried out through the use of digital environments and the established information database. As files are sent back and forth between the designers, engineers and manufacturers decisions are made regarding last minute modifications and adjustment to optimize the manufacturing process.

### **Achieving Variability through Mass Customization**

The fabrication of modules is highly dependent on the repetitive mass production of identical parts, however the independency of the parts allows for flexibility as they are easily interchangeable with other similar ones. This creates opportunities for the production of a diverse range of end products as it provides end users with the ability to easily personalize products that are initially fabricated from an array of mass produced identical parts. This method for achieving variety, known as mass customization, depends greatly of course on decisions made at the early stages of design that define the best approaches to break down products into smaller parts and

---

<sup>12</sup> Kieran, Timberlake, " Refabricating Architecture", p.79

defines the relationships between these parts. These strategies for customization as outlined by Joseph pine<sup>13</sup> are as follows:

a. Component-sharing modularity

Products of identical function are designed to have the capacity to change some aspects of their aesthetical characteristics such as color pattern and texture while maintaining the fixed function (Fig 6.1 & 6.2).



Figure 6.1 Swatch watches

Figure 6.2 Nokia cell phones

b. Component-swapping modularity

Products maintain the same appearance but have the capacity to interchange major parts within their assembly that provide different functions (Fig 6.3).



Figure 6.3 Personal Computers

<sup>13</sup> Shodek, Bechthold, Griggs, Kao, Steinberg, " Digital Design and Manufacturing", p.156

c. Cut-to-fit modularity

Products of a two dimensional or extruded linear nature in at least one axis allow consumers to customize the product by cutting to the required length (Fig6.4 & 6.5).



Figure 6.4 Cut to fit jeans

Figure 6.5 Wire

d. Mix modularity

Two or more products are mixed to create a new one (Fig 6.6).



Figure 6.6 paint colors

e. Bus-modularity

A standard base is used as the frame that supports a combination of other parts. The characteristic of this frame determines the type of parts it can support (Fig 6.7).



Figure 6.7 Car frame

f. Sectional modularity

Different parts having different characteristics whether in form or function share a standard interface through which these different parts could be joined as they are assembled together (Fig 6.8).

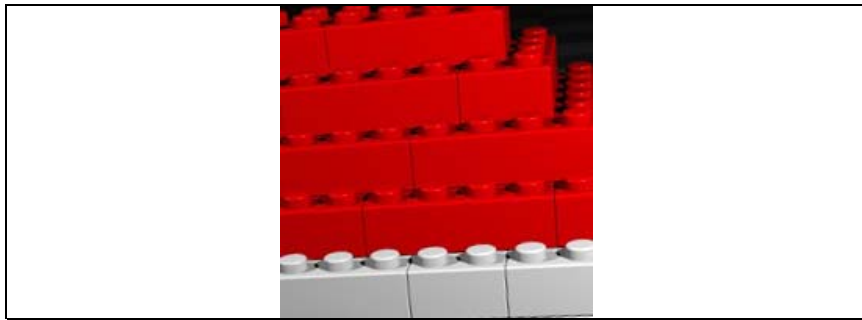

Figure 6.8 Sectional modularity in Lego blocks

### **Applications in the Automotive Industry**

Ford Motor Company's realization of the importance of product variety is reflected through its wide array of car brands that include Ford, Lincoln, Mercury, Mazda, Volvo, Jaguar, Land Rover, and Aston Martin. Each of these brands carries more variation through numerous models aiming to satisfy the needs and tastes of consumers. The design process<sup>14</sup> at Ford is initiated by market research in an effort to generate ideas and provide inspiration. For example, market research conducted in the

<sup>14</sup>Ford Motor Company, "Designing a legend", 26<sup>th</sup> Mar, 2006, <http://www.ford.com/en/heritage/centennial/default.htm>



early 1960's indicated that baby boomers, who were the prospective consumers at that period, preferred cars that are not only fast and affordable but also stylish, to which the Mustang came as an answer. Another source of inspiration include creative flashes for new or renewed shapes; the driving force behind the design of the Original Lincoln Continental that carried influences from Edsel Ford's exposure to sleek European vehicles. Even engineering requirements could be an idea generator as in the case of the design of the Jaguar D where the sensuous curves resulted from efforts towards and improved aerodynamic performance. Concept cars, which are basically experimental designs developed in an effort to push creativity and imagination to the limits and provide inspiration away from the practicalities of engineering and financial limitation. This method could lead to exciting new ideas that can be tamed later through realistic development for automotive mass production. In any case whether market research was the sole source of inspiration for the design of a vehicle or not, information obtained through this research helps ground the design ideas into reality as the design team together with engineers and mechanics, responsible for technical requirements and limitations, establishes basic presets for the project such as the vehicle type, its rough dimensions, and major elements such as the number of doors and seats. Through this process the design brief for the 1962 Mustang was established as a sporty 2 door 4 seat vehicle, no more than 180 inches in length and 2,500 pounds in weight, with a powerful 6 cylinder engine.

The generated design brief takes form in the subsequent preliminary design stages which is based on the generation of sketches whether manual or through digital means to brainstorm and stimulate ideas. These ideas can come from many sources, some of which may be past vehicle forms, other areas of industry or nature. Yet these ideas should accommodate other considerations related to comfort, safety, prevailing tastes and trends not to mention mechanical elements, manufacturing, financial and timeframe realities posed by engineers, manufacturing specialists, management and

marketing. The initial sketches produced aim to capture the essence of the vehicle, experimenting with different lines, proportions and expressions and are basically simple with very little or no color and shading, generally depicting the form from several different views (Fig 6.9). The best of these sketches are chosen for further refinement with the aid of CAD applications where large scale renderings and blueprints are generated to facilitate detailed studies. The use of CAD applications at this stage provides flexibility, saves time, and facilitates the transition of the design from 2D illustrations to 3D models.

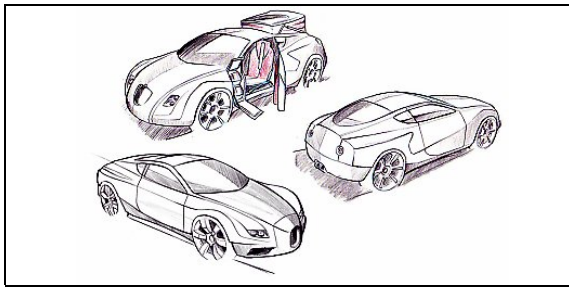

Figure 6.9 Conceptual hand sketches



Figure 6.10 Full scale clay study model

Full scale 3D models both physical and digital allow detailed studies of the form, allowing for more precise measurements and providing an opportunity to obtain input from engineers and manufacturing specialists regarding the practicalities of fitting mechanical components and the realities of manufacturing in order to facilitate the smooth production of the design (Fig 6.10). Physical models can also play a role in tests that do not necessarily require a functioning vehicle such as the wind tunnel tests of the aerodynamic performance of certain shapes, whereas digital models facilitate more advanced testing capabilities through digital simulation.

As design evolved gradually through several iterations, compromises between aesthetic ideal and practicality and production limitations shape the final product. Through the use of CAD/CAM applications, the subsequent engineering and manufacturing processes are simplified as the specifications are automatically

calculated and generated information is seamlessly transmitted to manufacturing instructions.

Ford refers to its manufacturing system as the “Flexible Manufacturing” approach as it uses machinery and equipment that are flexible enough to switch production between different models without significant interruptions. Yet flexibility in the manufacturing process adapted by the company extends to include the products produced in addition to the manufacturing equipment. Two strategies govern the flexible manufacturing approach followed at the Ford manufacturing facilities. The first of which is the Modularization of machinery and equipment used in production where specific tooling parts of these equipment are interchangeable if needed to accommodate production of different models or parts. This eliminates the necessity to change entire machines and pieces of equipment. On the other hand other machinery may not facilitate this interchangeability yet allow the software used to run the equipment to be reprogrammed easily to carry out different sets of operations whenever changes in production are necessary. Modularization extends to the products produced as each vehicle is composed of hundreds of modules allowing the ability to outsource parts to suppliers for better quality, lower cost, and ease of assembly of final products as well as providing the option of interchangeability of accessories and customization of interior finishes. The other strategy is standardization of equipment, parts, processes and workflow which reduces cost of materials purchased due to the advantage of the economies of scale. Standardization of processes and workflow facilitates ease and speed of process as the workers require less time to get familiar with the operations necessary for production due to their similarity, and it also allows exchange of knowledge and expertise between different jobs and even between different manufacturing plants when ever necessary. Like modularization, standardization extends to incorporate the manufactured vehicles as they share common architecture when it comes to their components, engineering, and basic structures, an applied

example of this standardization are the Ford 500 Sedan, the Ford Freestyle and the Mercury Montego models which are all assembled using the same shared platform (Fig6.11); a strategy better referred to as bus-modularity according to Joseph Pines mass customization principals.



Figure 6.11 The Ford 500 Sedan, Ford Freestyle and Mercury Montego sharing one platform

### **Applications in the Aerospace Industry**

Boeing's engagement of CAD/CAM technologies within its design and manufacturing processes started in the mid 1980's with the collaboration with both Dassault systems the developer of CATIA and IBM, the CATIA service provider in the United States to deliver products and services for the 777 production program. The design of the 777 aircraft involved several teams each concerned with the development of specific aircraft parts. Each of these teams combined designers, engineers, manufacturing representatives, tooling specialists, financing experts, suppliers, and customers. While the members of a single team worked from the same location, the different 238 teams working on the 777 program were located in different geographical areas and communicated using a sophisticated digital network with huge mainframes located in Kansas, Japan, and Philadelphia among other locations. This communication system facilitated the concurrent collaboration of the different teams as opposed to the sequential collaborative design process model<sup>15</sup>.

<sup>15</sup> Boeing, "Boeing 747, 767 And 777 Manufacturing Site", May 3<sup>rd</sup>, 06  
<http://www.boeing.com/commercial/facilities/index.html>

At the early stages of this collaboration, Boeing suggested a number of enhancements to the system used in order to take full advantage of its capabilities in the aerospace industry. These modifications and enhancements were related to the data management, used productivity and visualization capabilities of the software. The changes allowed engineers to design entire aircrafts by using the 3D digital environment to view parts as solids, simulate their assembly, and detect part interferences, overlaps, and misalignments as parts are fitted together, thereby solving the problems designated the most common in airplane manufacturing based on Boeing's research. Further advantages of the use of technology at Boeing was the reduction of time and cost associated with the production of physical mock up and the ease of simulation of the overall geometry of the aircraft digitally. Moreover, the quality of the airplanes designed improved due to the use of 46 different computer controlled mechanical testing machines and capabilities that test durability, static properties, damage tolerance, Acoustics, and aerodynamics among many numerous other aspects.

The positive results of the application of technology in the design and manufacturing process at Boeing was affirmed in 1989 as studies showed that the 777 program exceeded its goal of reducing change, error and rework by 50%. Studies also showed that the accuracy of the first 777 produced reached to the limits of 0.023 of an inch in comparison to other aircrafts where parts lined up to within half an inch of each other. The advantages of the technology implemented at Boeing were clearly manifested with the launch of the 777 twinjet in 1990.

As established, the design process at Boeing aims to reduce time, cost and error as it increases quality. This is achieved through following basic principals of industrial design that promote simplification and standardization of parts to provide grounds for mass production. The application of these principles is very apparent in Boeing's Everet, Washington's manufacturing facility. The gigantic structure receives on daily bases, over one million parts and assemblies from suppliers located all over the world.

The 767 airplane alone is comprised of 3.1 million parts provided by 800 different suppliers, while the 747 requires 6 million parts. In an effort to further simplify the manufacturing process, the 767-400 ER flight deck instrument panel is designed to have 85% fewer parts than other 767 aircrafts. This was achieved through the use of cast parts which reduced the total number of components used in the panel to 53 from 296 reducing the assembly time to 20 hours from 180. Similarly the number of parts in the next generation 737 aircraft was reduced to 367,000 components only (Fig 6.12).

Quality of production is not only achieved through the simplification, standardization and reduction of the number of parts but also through creating ergonomically comfortable working condition that ensure precise and accurate assembly of the parts as they come together to form larger components.

Customization of aircrafts is carried out at the final manufacturing stages, where the aircraft exterior may be painted and the interior fixtures are specified to match the purchasing airlines markings and color schemes (Fig6.13).

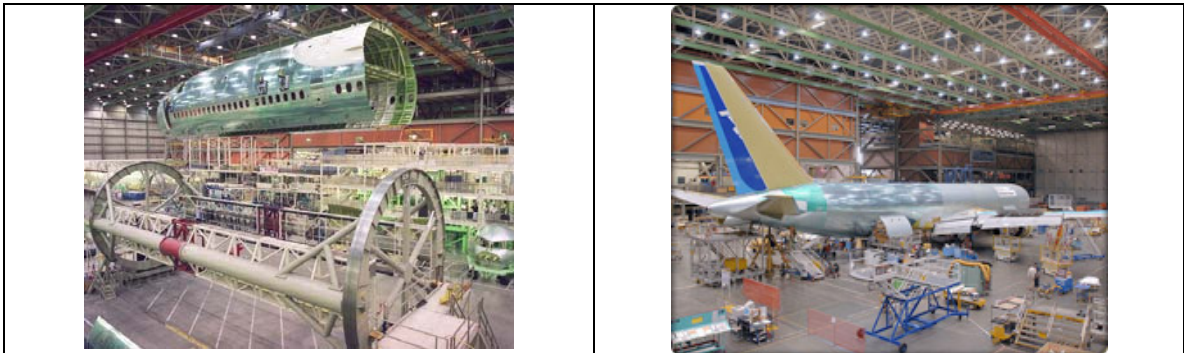

Figure 6.12 Automated assembly of a Boeing 777 modules

Figure 6.13 Customization of the aircraft through application of exterior color schemes

## Conclusion

The need for variation and diversity is intrinsic in the field of industrial design. Yet the design process in this field focuses mainly on enhancing the quality of the products designed and facilitating the smooth manufacturing of products as a priority

though incorporating the input of engineers and manufacturing specialists at the very early stages of the process and following design for manufacture strategies (DFM). Rather than focusing on generating unique attractive forms. The most suitable design proposal is that achieving the balance between form, quality and performance, and flexibility and ease of manufacturing. Furthermore, although the industry, specifically the aerospace industry, pioneered the incorporation of CAD/CAM in design and production, it remains very cautious as to how it is incorporated within the process eliminating its use from the early idea and form development stages and restricting its applications to enhancing performance capabilities, engineering studies, and manufacturing operations.

Inevitably Design for a smooth mass production processes calls for high levels of modularity and standardization of parts, components, operations and processes. Furthermore it requires simplification of details and avoiding complexity and variation. Yet this enforced modularity do not form an obstacle to achieving diversity in production for it is through principals of modularity and standardization that the industry was enabled to successfully achieve variation as these principals facilitate the application of the principals of mass customization. Hence the industry achieves quality and variation as a byproduct of the design of a smooth and simplified manufactured process.

**Key Points**

- Developments in the field of industrial design over the past century reinforced the need for variation and diversity of products with similar functions to satisfy the demand for expression of individuality and to maintain a competitive edge in the market. Industrial design was successful in incorporating emerging technologies to mass produce high quality commodities that satisfy consumer demands and expectations. This success stems from the design, manufacturing, operation and delivery process followed which depends on the integrative collaboration of a team that includes marketing experts, designers, engineers and manufacturers throughout the conceptual ideation, design development, and manufacturing phases. Through this collaborative team effort, informed decisions regarding the most suitable technological applications and design and manufacturing methodologies are reached.
- The conceptual ideation phase in the Industrial Design (ID) process is initiated by thorough market research and consumer studies followed by hand sketched drawings to capture the essence of the form and image of the product. Digital applications do not play any major roles in the form finding process in industrial design.
- In the design development phase, hand sketches are consequently converted to the digital environment for further elaboration and detailed performance testing. Physical models produced both manually and with the aid of CNC capabilities provide means for further performance studies. Several strategies and software environments may be pursued in this phase. Nevertheless, they all stress the necessity to simplify parts and eliminate unnecessary information and dependency and interrelation of product parts whenever possible. Thus, digital environments with parametric design capabilities are increasingly playing an



important role in reducing product development time as well as reducing development costs.

- While simplification is easier to achieve at smaller simpler products, the complexity associated with the design and fabrication of more complex products such as the case in aerospace and automotive design is best controlled when products are broken down to several manageable chunks which are further simplified to smaller parts that are generally referred to as modules. This approach simplifies the design and fabrication process and increases the quality of the products as it enables utilizing expertise of manufacturers who specialize in the production of each part as well as allows for parts to be manufactured at different locations wherever it is most feasible. The advantages of such an approach is further reduction in design and fabrication time as parts are designed and fabricated simultaneously, minimizing the possibility of errors in fabrication due to simplification of the process, and the resulting flexibility of interchanging product parts.
- The capacity to interchange modules plays a great role in facilitating the mass customization of products through which a diverse pool of products is achieved. Several approaches for mass customization are established ( component sharing modularity, Component swapping modularity, Cut to fit modularity, Mix modularity, Bus modularity, Sectional modularity) as proposed by Joseph Pine.
- In the Manufacturing phase, flexible manufacturing approaches compatible with the design and modularization strategies, are utilized for production in order to seamlessly adjust to tweaks and changes in products designed thus economizing in terms of cost and time necessary for production

CHAPTER VII  
FINDINGS AND ANALYSIS

In Chapter 1, the Introduction, we stated the hypothesis as follows:

*US Manufactured Housing is deficient due to the inability of industry to leverage technological solutions as found in other Industrial Design/Manufacturing processes.*

Following is a summary of the main Proof statements presented in previous chapters:

1. Architects' interest in housing the masses did not emerge until the 20th century; this followed the industrial revolution and subsequent technological developments. Prior to the 20th century, people's housing needs were typically fulfilled by the masses themselves. This established a tradition of close resident (i.e. owner) customization and psychological and sentimental attachment to the housing unit.
2. Architects of the Modern Movement were compelled by the impact of technology and mass production in the automotive industry; this resulted in early modern architects experimenting with the application of the principals of mass production to mass architecture's sole commodity, the housing unit.
3. Walter Gropius, Le Corbusier, Buckminster Fuller, Jean Prouve, The Archigram Movement, Moshe Safdie, Paul Rudolph, and Kisho Kurokawa are a few of many notable architects with significant mass housing proposals. These proposals were confronted by many collaborative, political, and regulatory obstacles. Additionally, these proposals often lacked congruent technology and often the architects were unable to resolve the complex demand to balance between performance, production requirements and aesthetics (Table 7.1).

Table 7.1 Summary of mass housing attempts in the past century as presented in Chapter 3

Architect	Walter Gropius		Le Corbusier	Buckminster Fuller	Jean Prouve	Archigram	Moshe Safdie	Paul Rudolph		Kisho Kurokawa	
Proposal	Copper House	Packaged House	Q.M.F.	Dymaxion Living Machine	Tropical House		Habitat	Graphics Arts Center	Oriental Masonic Gardens	Takara Beautillion	Nagakin Tower
Material											
Concrete			√				√		√		√
Wood		√						√	√		
Metal	√			√	√	√		√		√	√
Primary Shape											
Spherical/ Curvilinear				√		√					
Square/ Rectangular/ Linear	√	√	√		√	√	√	√	√	√	√
Type of Factory Built Structure											
Pre Cut											
Panelized	√	√			√						
Modular			√			√	√	√	√	√	√
Manufactured				√		√					
Obstacles											
Financial	√	√	√		√	√	√		√		
Political/ Regulations	√		√				√	√	√		
Transportation									√		√
Technology & Performance				√			√				
Aesthetics & Appeal			√	√	√	√				√	

4. The current US manufactured home industry evolved from early automotive industry techniques. However, this link to ‘manufactured’ industry design and production principals, to include aesthetics, was abandoned in the 1970’s with the adoption of “site built” homebuilding techniques in the MH factory.
5. Currently, based on data obtained from the Manufactured Housing Institute (MHI) and the U.S. census Bureau, manufactured housing shipments and sales

have declined significantly over the past decade, with the recent exception of hurricane ravaged areas. On the other hand, conventional single family “site-assembled” housing has seen a rise in the per square footage cost of conventional housing relative to manufactured home prices. This suggests that manufactured homes are losing their appeal as an affordable housing alternative.

6. Generally, the MH industry has made minimal investment in Research and Development (R&D) resulting in minimal improvement in production since the 1970's. Generally, the MH industry uses a manual labor process similar to site built (assembled) construction. Such a production strategy does not take advantage of the industry's main asset, the factory production environment.
7. Due to the dependence on an untrained unqualified labor force, the exclusion of technological applications, use of cheap low quality construction material, and the emphasis on the manufacture of the entire housing unit in the factory in an effort to reduce the unit cost (Fig 7.1), The manufactured home suffers from several hazards that are summarized in the seven following points:
  - o Excessive flammability: According to a report issued by US administration National Fire Data center in October 2004, MH units have the highest death rate per thousand fires among all other types of residential and non residential structures, killing 271 people and costing \$120 million in losses in 2001.
  - o Vulnerability to extreme weather conditions: Based on information obtained from the National Oceanic and Atmospheric Administration, Manufactured homes suffer more wind damage in comparison to conventional housing during hurricanes and tornadoes. Furthermore, based on statistics obtained from the manufactured housing institute,

the majority of MH housing units are poorly fixed to their foundation. This increases their risk of being damaged as they are pushed off these foundations by flood waters and storm surges. Such damages contribute to an overall annual fatality rate of 162 people and an annual dollar loss exceeding \$11.5 billion due to severe weather conditions which is not exclusive to manufactured home damages.

- Low Indoor air quality: According to research published in the American Journal of Public health, manufactured housing structures excessively emit noxious fumes that have adverse health effects. Bearing in mind that elderly over 65 years in age form the prime category of manufactured home residents, manufactured homes' low indoor air quality emerge as a possible cause contributing to a yearly death toll of over 100,000 elderly over 65 years in age who die due to chronic respiratory diseases and to an overall annual elderly health expenditure exceeding \$200 billion according to a report issued in September 2004 by the U.S. Department of Health and Human Services.
- Financing and Insurance complications arise due to the limited collateral associated with manufactured homes in light of their deficient performance. Such complications include higher financing and insurance interest rates which are not tax deductible, shorter loan periods and the units' depreciation in value. Such financial drawbacks are important and ironic
- Issues posed by this "affordable" housing solution to resident who are mainly attracted to the manufactured home unit because of their financial restrictions.

- Lack of Durability: According to a study conducted in 1999 by the NFO Research Inc., MH units have limited durability with simultaneous problems relating to construction emerging within the first year of ownership and costing \$1000 on average to fix.
- Transportation of the manufactured home unit imposes several dimensional, weight and aesthetical restrictions. Such limitations contribute to the unit's problematic performance and lack of appeal. Furthermore, problems that arise during transportation and installation process are both dangerous and expensive costing \$750 on average to fix according to a 1999 NFO Research Inc. study.
- Prejudiced perception established by the deficient performance, financial complications and the lacking aesthetic of manufactured homes, leads to the creation of local government laws that mandate zoning manufactured homes out of single family housing communities to edges of cities away from jobs and services.

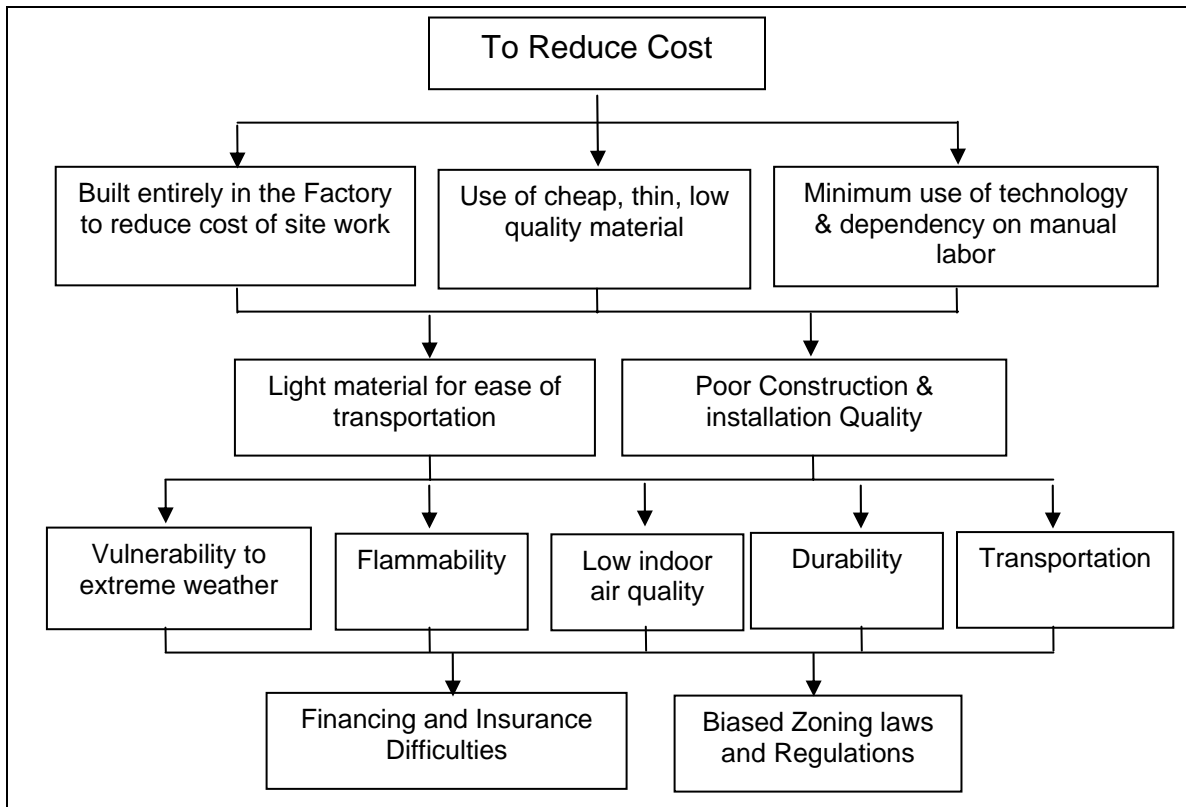

Figure 7.1 Summary of causes and effects of manufactured housing problems as presented in chapter 4

8. The early role of CAD applications focused on managing the complexities of rationalization and construction of curved geometries; examples are the Sydney Opera House and the Kansai Airport. Generally, technological applications did not play a significant role in the early conceptual and form generation stages during this early era of computing. However, as architects became familiar with the capabilities of technology various approaches to CAD/CAM have evolved, the following is a general overview:

- Frank Gerhy's approach excludes the use of technological applications from conceptual and form generation stages, focusing on maximizing the digital and CAD/CAM capabilities to seamlessly generate geometric

variations during the design development phase and to further manage component variations in an organized manner during construction.

- Norman Foster's relies on the use of parametric capabilities for form generation in addition to CAE capabilities to produce analytical studies that influence the form generation process. While Foster strives to utilize technology to streamline construction, the nature of the forms generated usually demands a level of customization of building components, a process in which digital means play an important role in design rationalization and managing of the construction process.
- Bernard Franken uses digital applications as a means of form generation based on the application of hypothetical forces extracted from the context and image of the project to morph basic shapes. This process relies on CAD/CAM capabilities to generate and keep record of the resulting highly customized structural as well as skin components.
- Greg Lynn proposes the use of animation oriented software to capture a sense of motion in structures. This process generates unpredictable and usually extremely complex forms requiring extreme customization of parts and components. Therefore, construction of these forms relies heavily on the use of digital applications and CNC capabilities in managing fabrication information.
- SHoP architects borrow some of the principals of industrial and product design. This strategy incorporates the use the digital environment to shape the form of the final structure based on the site, budget and performance constraints among several other restrictions. This approach includes the construction process where SHoP works to reduce site work by maximizing prefabrication to ease on site assembly. While this



reduces costs greatly it still depends to a great level on technology to generate and fabricate the variety of forms and components. Though architects approaches to incorporating technology in practice varied, these approaches share in common several factors:

9. Though architects approaches to incorporating technology in practice varied, these approaches share in common several factors:
  - Computer applications enabled architects to pursue complex details, double curved geometries and facilitated the design of structures with various distinctively shaped parts without compromising control over the design and construction process. Attitudes inclined towards engaging technology in the form generating process are increasingly engaging parametric logic in this area. Communication of construction information that accurately define the designed forms, previously a massive obstacle to the realization of complex forms, ceased to be so with the use of both digital environments and CNC fabrication tools enabling the architect to be more involved with the idea of “making and manufacturing,” through collaboration efforts manufacturing experts.
  - Though CAE capabilities emerged along side CAD/CAM and CNC applications, their utilizations in architecture was restricted to informing the form generation process at “subsequent” stages in design development resulting in modifying and tweaking already set forms. This is in contrast to the Industrial Design process that drives form based on performance considerations.
10. Due to the high cost of CAD/CAM technology, generally they have not been used in architecture to generate commodity housing. However, there are high-art “expensive exceptions, this design process follows the same design methodology

used for larger projects where the high cost may be justified and “aesthetics” drive the form and design process. Thus, many of these housing projects proposed by architects remain unrealized or are restricted to elite clientele.

11. Generally, the architectural profession currently is mesmerized by possibilities for variation and customization promised by technology; typically, mass production principles are substituted with mass customization ideologies. This definition of mass customization however varies from that based on modularity and interchangeability of parts as used by other manufacturing industries that promotes variety and differentiation of components.
12. Over the past century, developments in the field of industrial design have reinforced the need for variation and diversity of products to satisfy the demand for expression of individuality and to maintain a competitive edge in the market. Industrial design was successful in incorporating emerging technologies to mass produce high quality commodities that satisfy consumer demands and expectations. This success stems from the design, manufacturing, operation and delivery process followed which depends on the collaboration of a team that includes marketing experts, designers, engineers and manufacturers throughout the design process. This collaborative team effort ensures that informed decisions regarding the most suitable technological applications, design and, manufacturing methodologies are reached.
13. The conceptual ideation phase in the Industrial Design (ID) process is initiated by thorough market research and consumer studies followed by hand sketched drawings to capture the essence of the form and image of the product. Digital applications do not play any major roles in the form finding process in industrial design.

14. In the design development phase, hand sketches are consequently converted to the digital environment for further elaboration and detailed performance testing. Physical models produced both manually and with the aid of CNC capabilities provide means for further performance studies. Several strategies and software environments may be pursued in this phase. Nevertheless, they all stress the necessity to simplify parts and eliminate unnecessary information and dependency and interrelation of product parts whenever possible. Thus, digital environments with parametric design capabilities are increasingly playing an important role in reducing product development time as well as reducing development costs.
15. While simplification is easier to achieve at smaller simpler products, the complexity associated with the design and fabrication of more complex products such as the case in aerospace and automotive design is best controlled when products are broken down to several manageable chunks which are further simplified to smaller parts that are generally referred to as modules. This approach simplifies the design and fabrication process and increases the quality of the products as it enables utilizing expertise of manufacturers who specialize in the production of each part as well as allows for parts to be manufactured at different locations wherever it is most feasible. The advantages of such an approach is further reduction in design and fabrication time as parts are designed and fabricated simultaneously, minimizing the possibility of errors in fabrication due to simplification of the process, and the resulting flexibility of interchanging product parts.
16. The capacity to interchange modules plays a great role in facilitating the mass customization of products though which a diverse pool of products is achieved. Several approaches for mass customization are established ( component sharing

modularity, Component swapping modularity, Cut to fit modularity, Mix modularity, Bus modularity, Sectional modularity) as proposed by Joseph Pine.

17. In the Manufacturing phase, flexible manufacturing approaches compatible with the design and modularization strategies, are utilized for production in order to seamlessly adjust to tweaks and changes in products designed thus economizing in terms of cost and time necessary for production (Fig 7.2).

Table 7.2 The Industrial Design approach to design and manufacturing

Conceptual Ideation	Establishing an Integrative Collaboration Market Research and Consumer Studies Hand sketched image and physical model form studies
Design Development	Comprehensive digital performance studies and form development Simplification and Standardization Design for Modularity Application of Mass Customization Strategies
Manufacturing	Application of Flexible Manufacturing Strategies

### **Proof of Hypothesis**

Our analysis in chapter 4 of the manufactured home industry and product provided insight into the typologies of prefabricated housing which include, alongside manufactured home units, modular homes, panelized homes, and precut, and to a certain degree site built home units. In the same chapter we analyzed the problems faced by the manufactured home industry. These problems could be summarized in seven major points as follows:

- 1- Excessive flammability
- 2- Vulnerability to extreme weather conditions
- 3- Low indoor air quality
- 4- Lack of durability
- 5- Financing and insurance complications
- 6- Transportation difficulties
- 7- Lacking aesthetic appeal and biased zoning laws and regulations.

Chapter 4 also outlines the cause behind these deficiencies to be the industry's prime focus on reducing the manufactured home unit's cost by concentrating on:

- 1- The entire production of the manufactured home unit in the factory to minimize onsite assembly expenses.
- 2- Use of cheap low Quality Material.
- 3- Minimum use of technology and the dependency on unqualified manual labor.

While research indicates that the manufactured home structure is deficient in several aspects, manufactured homes are not the sole prefabricated commodity housing typology. Furthermore, the minimum use of technology in the design and manufacturing process of manufactured homes is not the main cause behind its previously outlined deficiencies. Thus while our research findings support the hypothesis, it sheds light on the complexities of prefabricated housing typologies. In addition to that, research outlines several aspects, in addition to the use of technological applications, through which mass housing units could be enhanced. The following analysis clarifies these research findings.

### **Prefabricated Housing Categorization**

The potential of factory production in enhancing quality through repetitive fabrication in a controlled environment and affordability due to the economies of scale was pursued through the mass production of building components leaving it to the architect, builder or owner to formulate different configurations of these components. In this sense, it could be said that housing units whether classified as site built or factory built, are to one extent or the other, all based on the assembly of prefabricated elements.

Thus, construction of housing units generally referred to as site built, is based on using prefabricated components such as doors, windows, skylights, roof trusses, blocks and bricks, pre-cast slabs and walls, and wood boards and members produced in variations of widths, lengths and thickness that are conventionally used in construction to reduce the amount of work needed to shape them on site. Such houses which are site built and site assembled offer the largest flexibility for the generation of different variations in form and aesthetics however they also require the most site work, the longest time to build and the highest cost amongst all other types.

Factory built site assembled houses, includes three sub categories which are generally fabricated as systems in the factory, each of these options varies in its capacity to support customization and in the amount of site work necessary for assembly. These subcategories are precut, panelized and modular houses. Precut housing systems which are basically a collection of components that are cut and shaped in the factory to fit together onsite eliminating the need to reshape these elements. Precut system components are tracked using barcodes and serial numbers to organize delivery to site as per demand to accommodate the construction process. This system is the most flexible, the most costly and the most time consuming when it comes to assembly yet the most customizable within this category. Modular housing

systems on the other hand are the least customizable within the category as they arrive to site as prefabricated house sections, limiting the possible configurations. Panelized systems are a more balanced compromise between the capacity to achieve customization and ease of onsite assembly. The panelized system is based on the fabrication of floor, roof, and exterior and interior wall panels that are flexible enough to be assembled in a variety of configurations on site.

In the case of factory built factory assembled housing, commonly referred to as manufactured homes, the entire housing unit arrives onsite completely assembled ready to be fixed to the foundation. This option offers the least if any flexibility when it comes to customization but demands the least site work and thus less time and cost (Fig 7.4).

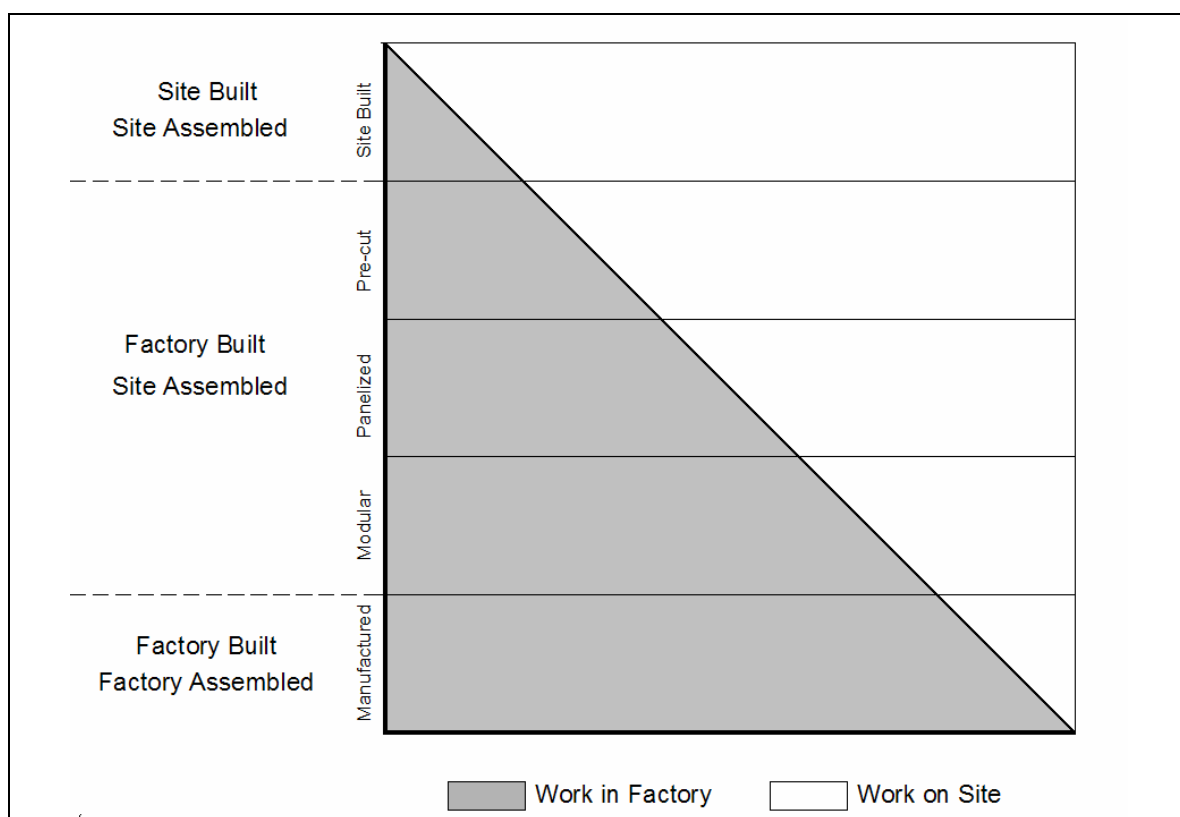





































Figure 7.2 Amount of work carried out in the factory, based on every category of housing types

**The Industrial Design Approach**

In chapter 6, we studied the design and manufacturing process followed in the field of industrial design as one of established success with respect to the mass production of commodities. As explored in chapter 6, these successes have been attributed, not only to the utilization of emerging technological advances but rather to the role that technologies played in design, manufacturing, operation, and delivery. Hence we analyzed the approach followed in industrial design chronologically through the three main phases, conceptual ideation, design development, and Product manufacturing with emphasis on the role that technology plays in each of these stages. Table 7.2 sets measure the approaches followed in Architecture, modern mass housing proposals and manufactured home production against that used for design and production in industrial design.



Table 7.3 Evaluation of the Industrial Design approach against approaches followed in Architecture, mass housing, and factory assembled housing

		 Requirement 100% fulfilled	 Requirement 75% fulfilled	 Requirement 50% fulfilled	 Requirement 0% fulfilled
Phase	Action	Industry	Architecture	Modern Mass Housing Proposals	Factory Built Factory assembled housing
Conceptual Ideation	Establishing an Integrative Collaboration				
	Market Research and Consumer Studies				
	Hand sketched image and physical model form studies				
Design Development	Comprehensive digital performance studies and form development				
	Simplification and Standardization				
	Design for Modularity				
	Application of Mass Customization Strategies				
Manufacturing	Application of Flexible Manufacturing Strategies, technologies and equipment.				

Though each of the outlined factors comprising the industrial design approach could be a topic for in depth study in terms of its relevance and the challenges confronting its application in architecture in general and the mass housing field in

particular, following is a brief overview of the potential of the application of these principles for the production of mass housing commodities.

### **Establishing an Integrative Collaboration**

While collaboration of different expertise is not a novel concept to the architectural profession, the current approach to establishing such collaborations echoes that of the iterative design process in industrial design which is, as clarified in chapter 6, giving way to the more integrative approach. As opposed to cooperating with different fields at different phases of the project as a means of executing a specific task in the process of getting the entire project underway, bringing various fields of knowledge in on the earlier stages of the design process is more advantageous specifically when designing for high volume mass production.

As architects rejoice in the fact that emerging technologies are increasingly enabling them to assume the role of the master builder which was thought to have been lost as the profession grew and diversified, this could ironically become an obstacle should architects insist on playing that role as they strive to achieve a mass produced housing solution. In contrast to the current state of events when it comes to practice in architecture, the industrial designer is an integrating member of a team where he influences as much as he is influenced by the expertise of its other members. As Gropius has predicted about a century ago, production of mass housing should involve a team of architects, engineers and businessmen, each having defined roles and responsibilities. Yet if such a team is to be formed, and based on the examples set by the past ventures in this field, this team should expand to include marketing specialists, production and manufacturing experts as well as individuals concerned with regulations and political issues if it is aiming to overcome possible obstacle that may arise in these areas.

### Market Research and Consumer Studies

Whether the Modernist approach in eliminating ornamentation in its housing proposals was a result of a condescending attitude towards improving public taste and elevating aesthetic values, or whether it was merely to facilitate engaging the tools of mass production by advocating simplification and repetition of form, is not as vital an issue to this argument as is the public's rejection of the Modernist's repression of their freedom of expression (Fig 7.6).



Figure 7.3 The indigenous versus the Modern

Perhaps this is illustrated best by Le Corbusier's Q.M.F. The housing units originally designed as state of the art housing solutions for mid to high income residents, eventually became housing for the poorer less selective individuals after they

were rejected by their targeted residents due to their austere and lacking appearance. Le Corbusier, who might have been in conflict with his own principles when he yielded to pleas to soften the aesthetic of the housing units in Pessac by using color, visited the project years following its completion only to find it transformed by exterior decoration and ornamentation that he long opposed (Fig 7.7). There Le Corbusier expressed his defeat “it is always life that is right and the architect who is wrong.”<sup>1</sup>



Figure 7.4 Residents reaction to Le Corbusier’s housing proposal in Pessac

Hence it is obvious that a careful study and consideration of the prevalent aesthetical taste and demands as to what makes the ideal house is a prime factor to formulating the mass housing solution as is the case with setting the image of products in industrial design. As the focus of market research differs according to the nature of products manufactured, mass housing units highlight specific issues worthy of exploration. These issues include the heritage of resident customization that is associated with the housing unit as opposed to other commodities that have emerged and proliferated through mass production. This demands exploration to clarify what is considered an acceptable threshold for individual expression and personalization of the housing unit.

---

<sup>1</sup> Boudon, Phillippe, “Lived-in Architecture: Le Corbusier’s Pessac”, The MIT press, Cambridge, Massachusetts, 1972, P. 1

### **Form and Performance Studies**

As illustrated in chapter 5, technological applications used in the industry are slowly penetrating today's architectural profession. Architects feverishly engage in exploring new avenues to integrating these applications in the design and construction process, lured by technology's implicit promise to shape new possibilities and blur lines defining limitations. As these digital applications gradually and vividly displayed their potential impact specifically in the design process, several approaches to their integration in practice surfaced in light of different philosophies and practice methodologies. The greatest disparity in these approaches is perhaps associated with the role of these newfound tools as a conceptual form generator in the design process (fig.). Some approaches choose to exclude technology's use from this phase all together, reluctant to indulge in giving total control of this process especially when it comes to the early conceptual phases though depending heavily on it in later stages of the process. Contrastingly other more submissive approaches rely completely on digital capabilities all through the process seeing no flaws in being "at the mercy of the computer". Bridging the gap between the two extremes are more moderate approaches that are more eclectic with their choices of digital tools and their applications. This mid ground in the application of digital means in the conceptual design process draws many similarities and to some extent resembles the use of technology in industrial design where the main focus of the use of computation in the design process, unlike in architecture, is to make products perform rather than to form the artifact.

Hence, taking the industrial design approach, given its proved successes in the field of mass production as a role model illustrating how to integrate technological advances in the design process, architects today face the challenge of mimicking that approach in their future mass housing attempts. In other words, architects will have to focus on utilizing technology to drive the quality of performance and increase

productivity as a main concern. This does not mean however that the aesthetical consideration and the creation of an appealing image of the project or product is neglected, but that it would be subservient to performance and production considerations. Undoubtedly this would require a massive shift in the mindset of the architect whose profession is focused on pursuing beauty, creativity and the necessity to achieve originality to be deemed successful.

### **Simplification and Standardization**

As detailed in chapter 5, Technology and Architecture, while the factory built housing industry has yet to experience the transformations and rewards of advanced technological applications, architecture has been blessed in the past decade with the advent of technology, originally used in industrial design, into its field. Needless to say, these new tools have transformed the architectural profession paving the way to new possibilities as it eliminates constraints. Though the impact of these technologies is multi faceted, for the sake of this argument, attention will be focused mainly on technology's influence on the generation of architectural form and its capacity to support the fabrication and customization of this form.

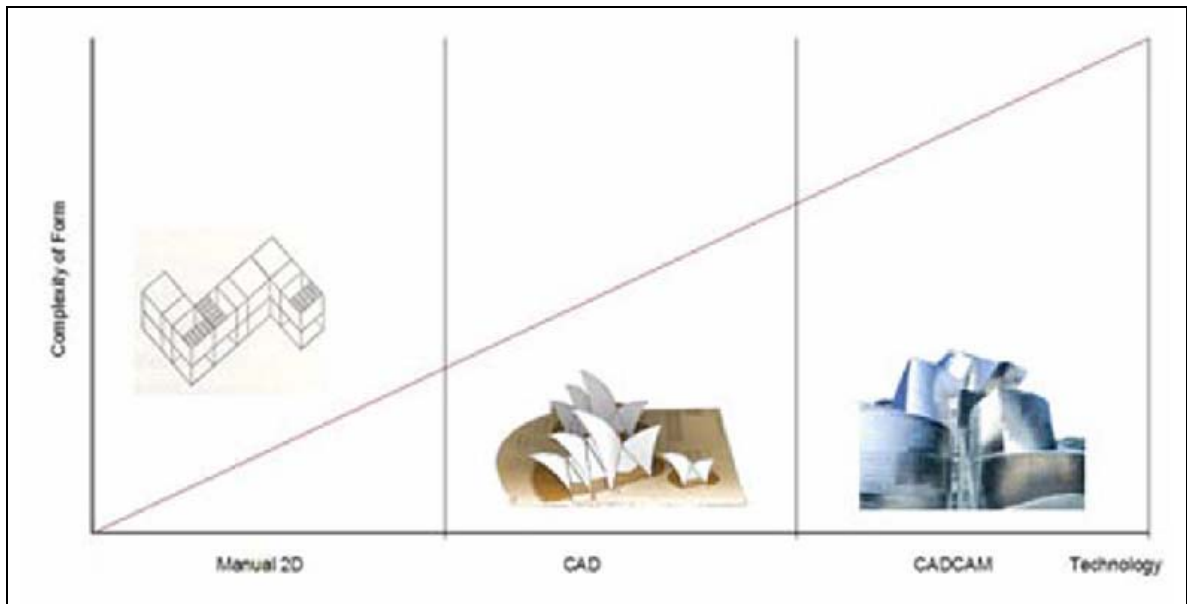

Figure 7.5 Impact of technology on architectural form

A simplified overview of the technologies used in architecture in the past century illustrates the influence of the used tools in terms of facilitating complexity of form and curvature (Fig 7.8). While approaches to utilizing today's technologies for form generation may vary according to the logic and theory behind them, a commonality emerges in that most if not all of these approaches utilize technology to derive complexity in form as a priority rather than primarily pushing performance, as is the case with industry.

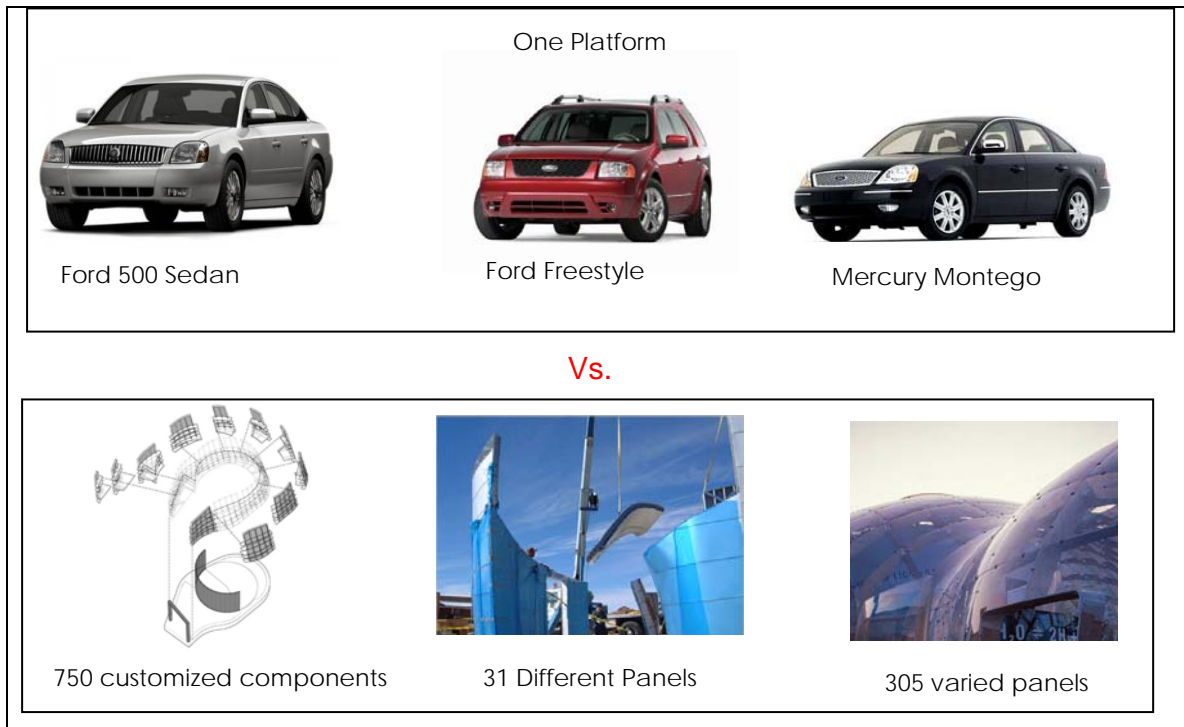

Figure 7.6 The industry's approach to utilizing technological applications versus architects' approaches to integrating technology in practice

In addition to that, though production in the industry is based on the breaking down of products into smaller parts to facilitate both flexibility in production and capacity for customization, this process is controlled by efforts to standardize, and simplify these modules to enhance the manufacturing process. In architecture, technology is used as means for unlimited differentiation to an extent that every component may be a uniquely designed part (Fig 7.9 & 7.10).



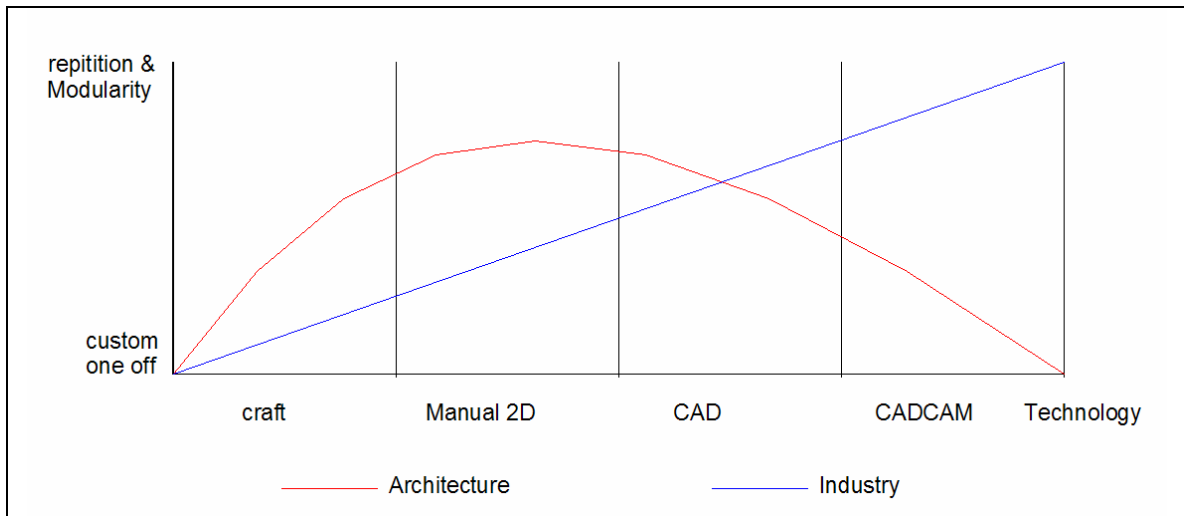

Figure 7.7 Today's technological applications enabling architects to get closer to the craft

### Design for Modularity

The application of modularity strategies as is the case in industrial design provides an opportunity for customization in addition to further benefits that include the following:

- 1- The opportunity to manufacture parts of high quality, at a reduced cost and in a shorter period of time as different parts are manufactured simultaneously. Strategies for modular production provide the opportunity to outsource production of parts to specialized manufactures whether locally or internationally utilizing technology to facilitate communication. This may facilitate taking advantage of reduced labor cost thus making a financial gain, seeking specific expertise or manufacturing technologies that are unavailable in-house yet are required to achieve higher production quality, or perhaps to take advantages of both factors if possible. Moreover, application of such strategies would eliminate the problems caused by the use of low quality materials and the dependency on manual labor in construction and assemblage to maintain an economic edge as in the case

of the manufactured homes production, thus avoiding the many problems that arise as a consequence as detailed in chapter 4.

Modular production could provide a solution to complications arising from the necessity to facilitate the transportation of the housing unit to site as in the case of the manufactured home unit. Following the industrial design model, after their production, modules and parts, leave their manufacturing facilities arriving at intermediate factories where they are assembled to form larger product components. The incremental assembly of these modules into larger sections, as assembly progresses forms an opportunity to create more ergonomically comfortable working conditions where manual labor is necessary which inevitably affects the quality of assemblage of the final product. The larger the assembled sections become, the closer is the location of the assembly facility to the final delivery location which in the case of the housing unit would be the final site (Fig 7.11).

As the components of the housing unit are broken down to smaller parts, their weight as well as dimensions are reduced eliminating the necessity to restrain the dimensions of the entire unit to facilitate its transportation along highways and through tunnels and to eliminate accidents that may occur or any defects that may happen to the unit as it is transported (Fig 7.12). Also, as the weight of the smaller units is enviably lighter than the weight of the entire housing unit making it easier to handle, this eliminates the necessity to use light material, by that avoiding any subsequent problems. Furthermore, breaking down the housing unit into smaller chunks helps organize the on site assembly process where modules could be delivered on as needed basis and based on the speed of the

assembly process avoiding clutter and protecting the finishes and materials from damage as they are exposed to the elements.

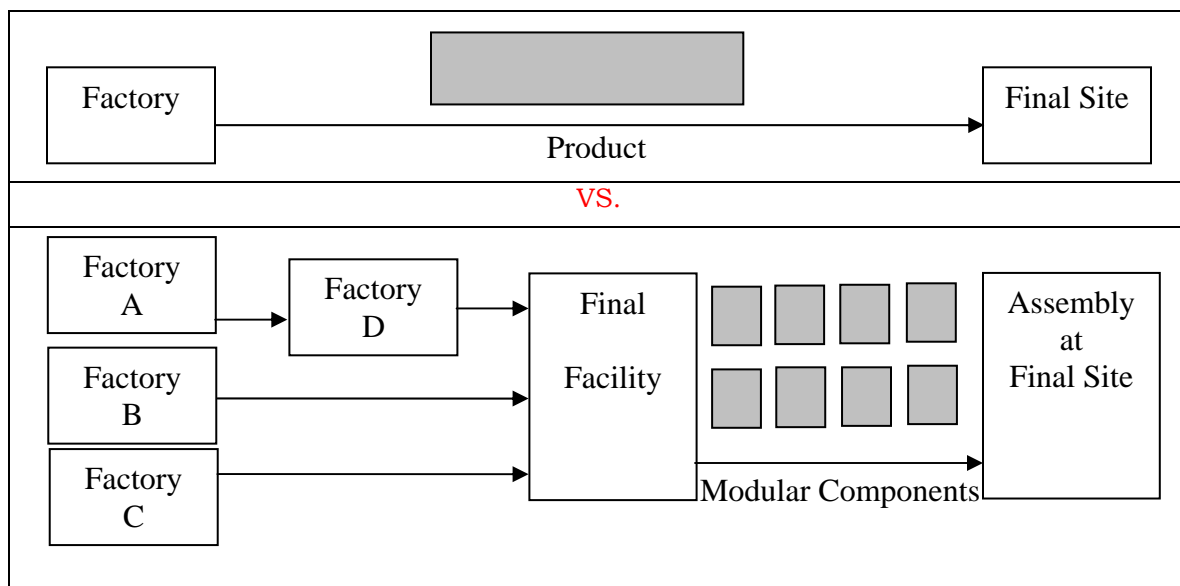

Figure 7.8 Transportation of the entire housing unit versus transportation of modular parts and components

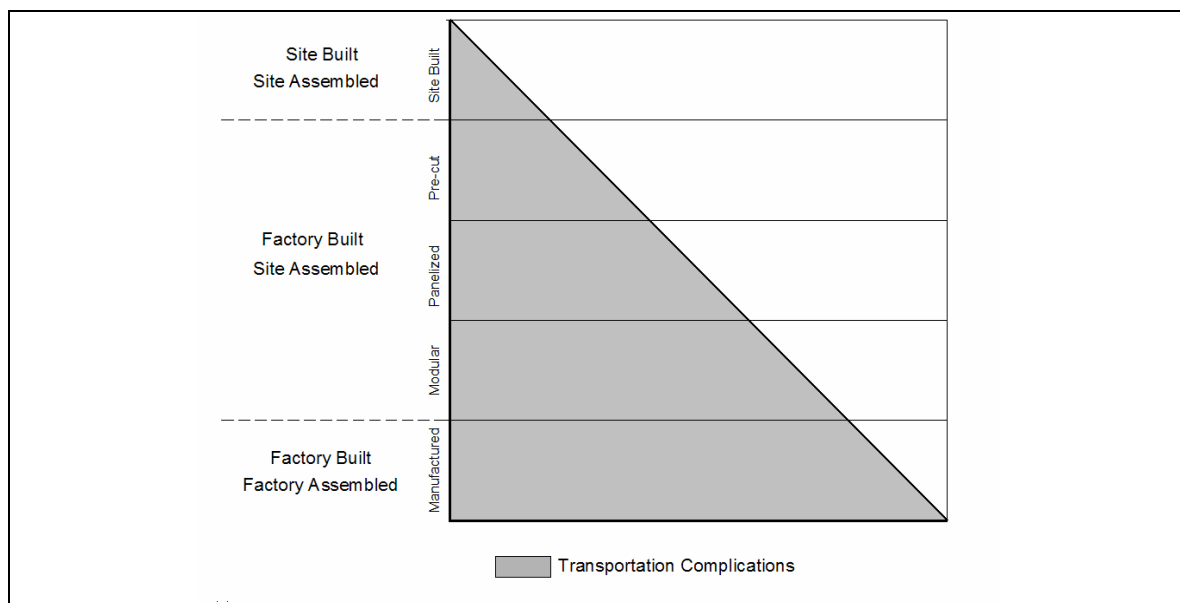

Figure 7.9 Transportation complications based on every category of housing types

### Application of Mass Customization Strategies

As illustrated in Fig 7.13, the capacity to support customization increases as the number of parts arriving on site increases and hence as work carried out in the factory is limited. Site built homes that deal with the assembly of the largest number of components on site provides the most flexibility to achieve variation through unlimited configuration options. As the smaller components are fixed to form larger parts in the factory, the capacity achieve variation is limited.

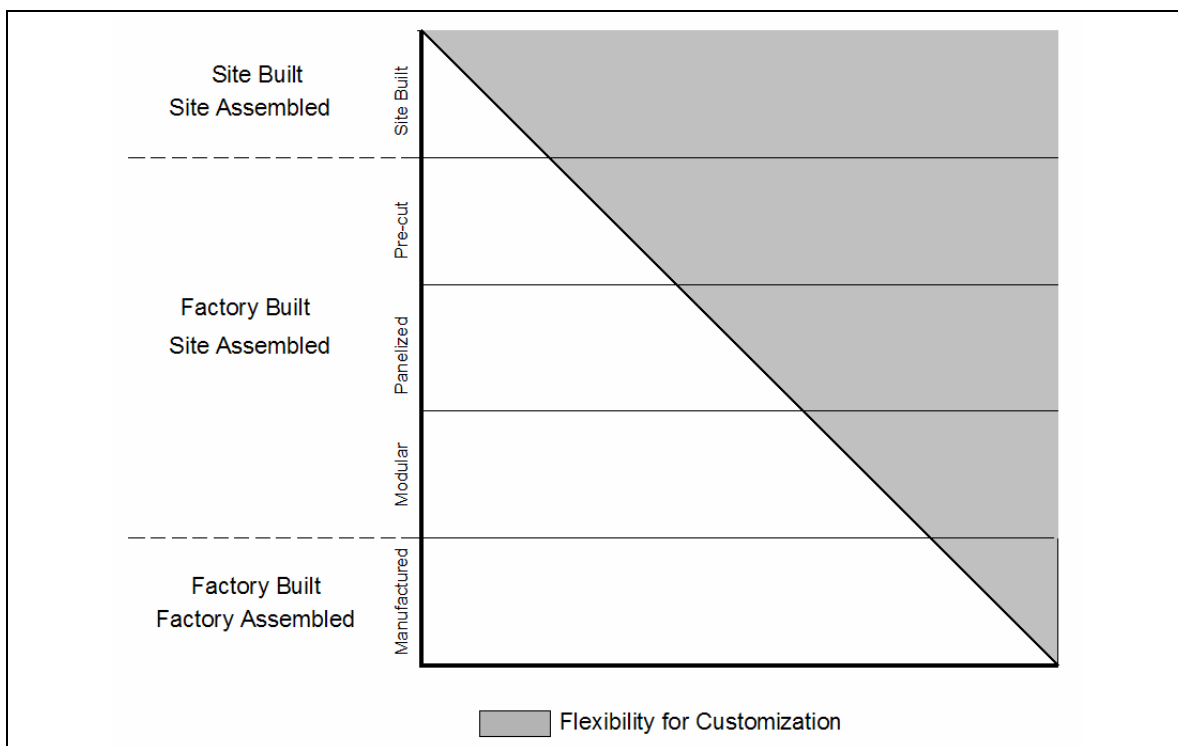

Figure 7.10 Flexibility for customization based, on every category of housing types

The majority of the solutions proposed by the modernist failed to achieve a balance between taking advantage of factory production and achieving flexibility for resident customization. This formed a major obstacle to generating a successful proposal for mass housing as modern architects aimed to produce the entire housing unit in the

factory. An exception could be made in the case of Gropius who consciously insisted that the “solution is not achieved through the design and construction of the whole housing unit but is arrived at through standardization of the housing components,” and that such a “venture will only be considered successful if it achieves a reasonable level of individuality and adaptability to change through interchangeability of parts while maintaining the economic advantage of mass production.” These ideas were perhaps behind the relative success of Gropius’ attempts in comparison to other proposals of the modern era, with the highest number of marketed housing units.

Contrasting to the Modernist’s efforts to utilize take the advantages of the factory environment, comes the efforts of architects today. Architects today see in technology the means to manufacture numerous parts that vary in shape, size and form arguing that technology makes it as convenient to produce 100 varying parts as it is to produce 100 identical ones. While this may be to some extent justified when contemplating custom one of projects, designing mass produced commodities, as seen in industrial design necessitates minimizing the number of different parts in order to benefit from the economies of scale of repetitive production.

Having both extremes displayed, that of the modernist striving to manufacture the entire housing unit in the factory and that of the contemporary architect rejoicing in technology’s ability to manufacture endless variations to be assembled on site, it is evident that in order to reap the advantages of mass production and arrive at a flexible customizable solution a balance between the two limits must be achieved.

### **Application of Flexible Manufacturing Strategies**

Although a great degree of flexibility is achieved through establishing a suitable tactic through which the housing unit is broken down to smaller modular components, establishing a compatible manufacturing process that complements the set strategy for modularity is an essential factor in the industrial design approach. Thus a study of the

most feasible manufacturing processes is a prime issue to be considered and set through the design team's collaborative efforts alongside the modularization strategy and the approach followed to achieve mass customization at the early stages of the design process.

While the construction process in both architecture and mass housing depends to a large extent on manual labor, manufacturing in industrial design takes full advantage of automation through the integration of robotics and CNC technologies in the production process. These technologies facilitate the provision of an ergonomic work environment in addition to speed and accuracy. The capacity to reprogram and tweak production lines is seamless through the reprogramming of software programs or through interchanging machine parts. This strategy, which mass housing production has yet to fully benefit from, flexibly anticipates any needs for future product adjustments and alterations without significantly interrupting production (Fig 7.14).

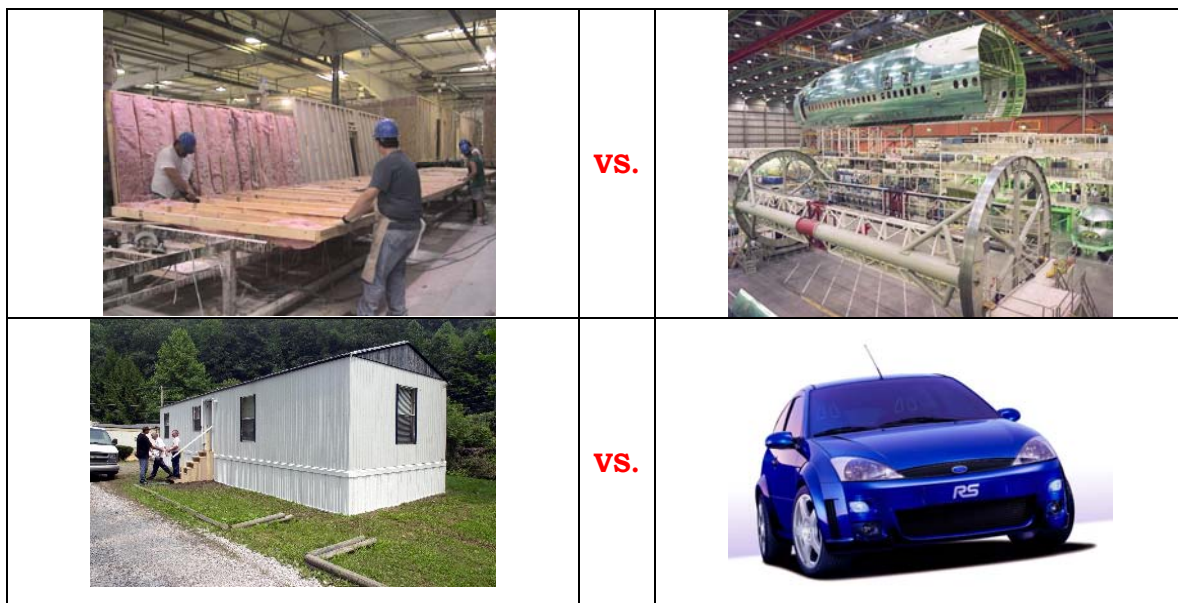

Figure 7.11 Housing production versus flexible manufacturing in industrial design

**Conclusion**

From the proceeding analysis we conclude that our assumption that the absence of technology in the design and production of mass housing commodities, specifically manufactured homes, is misleading. Research indicates that though manufactured home units do not benefit from the advantages of these technologies, other prefabricated housing typologies have witnessed their integration in the design and production process, however leading to minimal improvement towards arriving at an ideal permanent housing solution. Further analysis shows that the key to enhancing the production of housing commodities is found in the approach governing its use in the design, manufacturing, operation and delivery processes. While the previous analysis mainly focuses on the conceptual ideation, design development and manufacturing phases leading to the production of housing commodities, this approach could extend further to include the design for reuse, recycling, or demolition phases as is increasingly occurring in the design of various commodities in industrial design.

## CHAPTER VIII

### CONCLUSION

Mass housing can be improved by following an Industrial Design (ID) approach for the design, manufacturing, operation and delivery of commodity housing for the masses. Both current and past mass housing attempts have generally not achieved long term housing solutions as they lacked a balance between aspects of performance, aesthetics, and a capacity for resident personalization. The proposed Industrial Design in architecture approach proposes a balance between performance and production requirements. This mandates adherence to the design and production of repetitive components, and the architects' and residents' inclination to establish grounds for variety in form and a capacity for a unique individual expression.

This research enhances the understanding of the challenges confronting current architects in the mass housing industry.. Furthermore, this research establishes a greater understanding of factory built housing and the associated nomenclature. Moreover, it provides a comprehensive analysis of past architects' proposals in the field of mass housing resulting in insight to product and processes principles in architecture relative to commodity housing. This greater understanding achieved in each of the areas highlighted eventually contributes to reaching a poised mass housing solution that is inclusive of the performance advantages of industrial production and architecture's stress for beauty and customizable expressions, not only will such a solution help provide better quality housing to the masses, but it could also increase housing affordability and seriously tackle the homelessness problem that is rampant on a global scale today.



While this proposed approach promises a viable solution to the mass housing dilemma that supports flexibility for resident customization and future change not provided in current and past mass housing proposals; it is not without its limitations. The capacity of the level of customization achieved through this approach to satisfy residents' appeal is an issue to be further pursued. Further research is called for in the following areas:

- 1- *Establishing an integrative collaboration team:* an exploration into the necessary expertise to be sought for the formation of an effective team, and the clear definition of the roles of each of this expertise within an integrative collaboration for the production of housing commodities.
- 2- *Exploration of necessary fields to be pursued through market research:* A study of the historical, social, physiological factors and sentimental ties that are behind creating the occupants' perception of the ideal housing unit and their impact in establishing the prevalent aesthetical appeal and perceptions with relation to housing demand. In addition to that, a study outlining other relevant fields, such as the scale of the housing commodity in comparison to other products in industrial design and its associated implications in the design and production process.
- 3- *Investigating a methodology to guide the use of technology to enhance performance through form development:* the study of a methodology that mimics that used in industrial production to guide the use of technology for performance analysis and development while simultaneously informing and enhancing form generation. This would

ensure that housing commodities produced are not only visually pleasing but that form contributes to high quality performance.

- 4- *A study of feasible modularization strategies: to break down housing units into modular components:* This study should include the need for simplification and standardization, the capacity of the modular components to support mass customization strategies, flexible manufacturing tactics and the characteristics of these components in terms of size, weight, and function to name a few.

As presented earlier in the course of this research, technology has undoubtedly transformed the architectural practice, Nevertheless the impact of technological developments in improving the design and production of housing units remains to be minimal. Research indicates that this is not a result of the lack of utilization of technological developments in the design of mass housing commodities, but rather due to not following a suitable approach that exploits its potential for its integration. Hence we conclude that while technology brought architects “closer to the craft”, as expressed by Gehry; following an industrial design approach to the utilization of technology would bring architects closer to formulating a sound mass housing solution and thus closer to “the craft of architecture” as defined over 600 years ago by Ibn Kuldon.

## BIBLIOGRAPHY

- 1- PATH, <http://www.pathnet.org/>, 15<sup>th</sup>,October, 2004
- 2- Abu Hammad, Ayman A., “A Decision Support System For Manufactured Housing Production Process Planning and Facility Layout”, A dissertation submitted to the university of Cincinnati, 2003
- 3- Aho, Arnold J., “Scandinavian Manufactured Housing Potentials for Mississippi”, Mississippi State University, 1985
- 4- Architectural Record, <http://archrecord.construction.com/>, 10<sup>th</sup> June,06
- 5- Arcspace.com, <http://www.arcspace.com/>, 10<sup>th</sup> June,06
- 6- Ashby, Mike, Kara Johnson, “ Materials and Design; The Art and Science of Material Selection in Product Design”, Butterworth Heinemann 2002
- 7- Asia Source, <http://www.asiasource.org/>, 10<sup>th</sup> June,06
- 8- Baldwin, Carliss Y., Kim B. Clark, “Design Rules”, MIT Press,1999
- 9- Baldwin, Jay, ”BuckyWorks; Buckminster Fuller’s Ideas For Today”, John Wiley and Sons, 1996
- 10- Ban, Shigeru, David N. Buck, “ Shigeru Ban”, Barcelona, 1997
- 11- Bankrate.com, “Financing a Manufactured Home”,  
<http://www.bankrate.com/brm/news/mtg/19990722.asp>, 2<sup>nd</sup> Jan,06
- 12- Barrow, Larry R., “Cybernetic Architecture; Process and Form, The Impact of Information Technology”, A dissertation Submitted to Harvard University, 1998

- 13- Batchelor, Ray, "Henry Ford; Mass Production and Design", Manchester University Press, New York, 1994
- 14- Bean, Janet L., "The NIMBY Syndrome and Low Cost Manufactured Housing Developments: Can Landscape Help Overcome Community Opposition", Virginia Tech University, 13<sup>th</sup> Feb, 2004
- 15- Blair, Frederick H. Jr., "Mobile Homes and the General Housing Supply: Past, Present, and Outlook", Mobile Homes Manufacturing Association, 1970
- 16- Boeing, <http://www.boeing.com/>, 10<sup>th</sup> Mar,06
- 17- Boudon, Philippe, "Lived in Architecture", The MIT Press, 1972
- 18- Buchanan, Peter, "Renzo Piano Building Workshop Complete Works", Phaidon Press Limited, 1995
- 19- Builder Online Magazines, "Manufactured Home Listings", <http://www.builderonline.com/content/builder100/manf-home-listing-04.asp?sectionID=232>, 4<sup>th</sup> Jan, 2006
- 20- Center For Auto Safety, "Mobile Homes; The Low Cost Housing Hoax", Grossman Publishers, 1975
- 21- Dal Co, Francesco, Kurt W. Froster, "Frank O. Gehry: The Complete Works", The Monacelli Press, 1998
- 22- Davidson, Harold A., "Housing Demand: Mobile, Modular, or Conventional?", Litton Educational Publishing Inc., 1973
- 23- Design Museum, Archigram, <http://www.designmuseum.org/design/index.php?id=87>, 18<sup>th</sup> Nov 05
- 24- Dietz, Albert, Laurence Cutler, "Industrialized Building Systems for Housing", The MIT Press 1971
- 25- Drew, Philip, "Sydney Opera House, Jorn Utzon", Phaidon Press Ltd, 1995
- 26- Drury, Margaret J., "Mobile Homes; The Unrecognized Revolution in American Housing", Praeger, New York, 1972

- 27- Environmental Health Center, "Formaldehyde",  
<http://www.nsc.org/ehc/indoor/formald.htm>, 4<sup>th</sup> Jan, 06
- 28- Erhorn, Craig, John Stark, "Competing By Design", Oliver Wright Publications  
1994
- 29- Ettlle, John E., Henry W. Stoll, "Managing The Design-Manufacturing Process",  
McGraw-Hill Inc., 1990
- 30- Ford Motor Company,  
<http://www.ford.com/en/heritage/centennial/default.htm>, 12<sup>th</sup> mar,06
- 31- Franken Architekten, <http://www.franken-architekten.de/>, 10<sup>th</sup> Feb,06
- 32- Gehry Partners, "Gehry Talks; Architecture + Process", Universe Publishing,  
1999
- 33- Greg Lynn FORM, <http://www.glform.com/>, 10<sup>th</sup> Feb,06
- 34- Hammer Exhibitions, "Jean Prouve: A Tropical House",  
<http://www.hammer.ucla.edu/exhibitions/95/>, 30<sup>th</sup> may,06
- 35- Hartoonian, Gevork, "Ontology of Construction", Cambridge University Press,  
1973
- 36- Herbert, Gilbert, "The Dream of the Factory-Made House", The MIT Press, 1984
- 37- Holgate, Alan, "The Art in Structural Design; An Introduction and Sourcebook",  
Clarendon Press-Oxford 1986
- 38- Home Sight, Noji Gardens, <http://homesightwa.org/devnoji.htm>, 2<sup>nd</sup> June, 06
- 39- Ibn Kaldun, N. J. Dawood, Bruce Lawrence, Franz Rosenthal, "Al  
Muqadimmah", Princeton University Press, 1969
- 40- Jencks, Charles, "Le Corbusier and the Tragic View of Architecture", Harvard  
University Press, 1973

- 41- Jenkins, David, "On Foster ... Foster On", Prestel 2000
- 42- Jodido, Philip, "Sir Norman Foster", Taschen, 1997
- 43- Kieran, Stephan, James Timberlake, "Refabricating Architecture", McGraw-Hill, 2004
- 44- Kolarevic, Branko, "Architecture in the Digital Age: Design and Manufacturing", Spon Press, 2003
- 45- Kurokawa, Kisho, "Metabolism in Architecture", Westview Press Inc., 1977
- 46- Lindsey, Bruce, "Digital Gehry: Material Resistance/ Digital Construction", Birkhauser, 2001
- 47- Lorance, Loretta, "Building Values: Buckminster Fuller's Dymaxion House in Context", A dissertation Submitted to the City University of New York, 2004
- 48- Lynn, Greg, "Animate Form", Princeton Architectural Press, 1999
- 49- M. Ritchie, Ingrid, Robert G. Lehnen, "Formaldehyde Related Health Complaints of residents Living in Mobile and Conventional Homes", American Journal of Public Health, 1987
- 50- "Manufactured Housing; A Doublewide Analysis",  
<http://www.gsd.harvard.edu/studios/s97/burns/index.html> , 25th Jan, 2005.
- 51- Manufactured Housing Institute, "MHI: Manufactured Housing Institute",  
<http://www.manufacturedhousing.org/default.asp>, 25<sup>th</sup> Jan, 2005
- 52- Margolis, Richard J., " Mobile Homes and the Rural Poor; An Alternative Non-Solution", Rural Housing Alliance, Washington, 1973
- 53- Marks, Robert W., " The Dymaxion World of Buckminster Fuller", Reinhold Publishing Corporation, 1960
- 54- Mckean, John, "Crystal Palace; Joseph Paxton and Charles Fox", Phaidon Press Ltd. 1994

- 55- Metropolis Magazine, <http://www.metropolismag.com/html/>, 12<sup>th</sup> Mar, 06
- 56- Moholy-Nagy, Sibyl, Gerhard Schwab, Paul Rudolph, "The Architecture of Paul Rudolph", New Yprk, Praeger, 1970
- 57- Monk, Tony, "The Art and Architecture of Paul Rudolph", Wiley Academy, 1999
- 58- Morris, Earl W., Margaret E. Woods, "Housing Crisis and Response; The place of Mobile Homes in American Life", Ithaca, Department of Consumer Economics and Public Policy, New York State College of Human Ecology, 1971
- 59- Murray, Peter, "The Saga of Sydney Opera House: The Dramatic Story of the Design and Construction of the Icon of Modern Australia", Spon Press, 2003
- 60- NAHB Research Center Inc., "Factory and Site Built Housing: A Comparison for The 21<sup>st</sup> Century", U.S. Department of Housing and Urban Development, October 1998
- 61- National Oceanic and Atmospheric Administration, <http://www.nhc.noaa.gov/aboutsshs.shtml> , 29<sup>th</sup> Dec, '05
- 62- NFO Research Inc., "National Survey of Mobile Home Owners", AARP, July 1999
- 63- Nutt-Powell, Thomas, "Manufactured Homes; Making Sence of a Housing Opportunity", Auburn House Publishing Company 1982
- 64- Oliver, Paul, "Dwellings", Phaidon Press Limited 2003
- 65- Piano, Renzo, "Renzo Piano Building Workshop: In Search of a Balance", Process Architecture, 1992
- 66- Recreation Vehicle Industry, Media, <http://www.rvia.org/media/>, 5<sup>th</sup> September, 05.
- 67- Rural Studio, <http://www.ruralstudio.com/completehouses.htm>, 23<sup>rd</sup> Nov, '05.
- 68- Sanders, Welford, "Manufactured Housing Regulations, Design innovations, and Development Options", American Planning Association, Chicago, 1998

- 69- Schodeck, Daniel, Martain Bechthold, Kimo Griggs, Kenneth Martin Kao, Marco Steinberg, John Wiley and Sons, 2005
- 70- SHoP Architects, <http://www.shoparc.com/>, 12<sup>th</sup> Mar, 06
- 71- Steven Holl Architects, <http://www.stevenholl.com/>, 20<sup>th</sup> Feb,06
- 72- Sullivan, Barry James, "Industrialization in the Building Industry", Uniworld Industries, 1979
- 73- Sulzer, Peter, "Jean Prouve Highlights 1917-1944", Birkhauser, 2002
- 74- The Daily Telegraph Limited, " Storey with an Unhappy Ending: Paul Rudolph's Graphic Arts Center, New York, New York", 1968
- 75- The Moshe Safdie Hypermedia Archive, <http://cac.mcgill.ca/safdie/habitat/concept.htm>, 18<sup>th</sup> Nov, 05
- 76- The Tropical House Webcast, Jean Prouve: A Tropical House, [http://www.architecture.yale.edu/tropical\\_house/essay.htm](http://www.architecture.yale.edu/tropical_house/essay.htm), 30<sup>th</sup> May 06
- 77- U.S. Administration National Fire Data Center, " Fire in The United States, 1992-2001, Thirteenth Addition", October 04
- 78- U.S. Department of Health and Human Services, " Health, United States, 2004 with Chart book on Trends in The Health of Americans", DHHS Publications, September, 04
- 79- US Environmental Protection Agency, Sources of Indoor Polution, Formaldehyde, <http://www.epa.gov/iaq/formalde.html#Health%20Effects>, 2<sup>nd</sup> Jan 06
- 80- U.S. Census, "U.S. Census Bureau", <http://www.census.gov/const/www/index.html>, 13<sup>th</sup> Feb, 2005
- 81- U.S. Department of Housing and Urban Development, [www.hud.gov/](http://www.hud.gov/), 24<sup>th</sup> Jan, 2005
- 82- Utzon, Jorn, "Sydney Opera House, Sydney, Australia 1957-1973",



- 83- Williams, Barbra, "These Old Houses: 2001", US Department of Housing and Urban Development", Us Department of Commerce, US Census Bureau, Feb, '04
  
- 84- Wired Magazine, <http://www.wired.com/wired/archive/12.11/gehry.html>, 12<sup>th</sup>, Mar, 06.

APPENDIX A  
MH MANUFACTURERS' SURVEY QUESTIONS

Kai Pan  
 240 Giles Hall  
 Barr Ave. Mississippi State University  
 Mississippi State, MS 39762  
 P: 662-325-0530  
 F: 662-325-8872  
 Email: kp53@msstate.edu

School of Architecture  
 Mississippi State  
 University

# Fax

To: \_\_\_\_\_ From: Kai Pan  
 Fax: \_\_\_\_\_ Pages: 1  
 Phone: \_\_\_\_\_ Date: \_\_\_\_\_  
 Re: [Click here and type subject of fax] CC: [Click here and type name]

Urgent     For Review     Please Comment     Please Reply     Please

Recycle

Dear Mr.:

I am a graduate student in the School of Architecture at Mississippi State University.

My research area is Housing Industrialization and New Technology.

I want to know some basic information about your company. Would you please do me a favor to answer the following questions?

1. Does your company adopt new technologies, such as Computer-Aided-Manufacture (CAM), CNC Roller (or other CNC Machines) and Laser Cutter etc, in your plant.
2. Do you hire architects in your design group?
3. What do you think is the biggest problem or challenges that Manufactured Housing (or Modular Housing) Industry is facing?

You can call me, send fax, or email me.

Thank you very much for your help.

APPENDIX B  
CAVALIER HOMES INC. CASE STUDY

A CASE STUDY

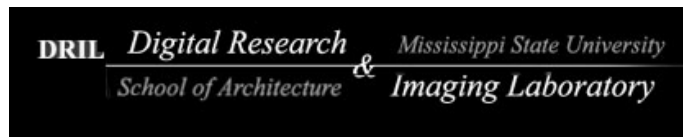

<http://www.dril.sarc.msstate.edu>

CAVALIER HOMES, INC.

INFORMATION TECHNOLOGY, DESIGN  
AND MANUFACTURED HOUSING

<http://www.cavhomesinc.com/>

A Case Study<sup>1</sup>**CAVALIER HOMES, INC.**INFORMATION TECHNOLOGY, DESIGN  
AND MANUFACTURED HOUSING

<http://www.cavhomesinc.com/>

In the early autumn of 2002, Jay Wilson, the Chief Information Officer of Cavalier Homes, a Manufactured Housing (MH) company, sat behind at his desk in his office in Addison, AL, looking outside the window, thinking about the unfinished SAP installation project. It was a cloudy day, similar to the dreary market Cavalier and the MH industry was facing. Jay believed that, empowered by IT, Cavalier would ride the economic downturn and be well positioned for the next economic upturn.

Jay Wilson, the son of Cavalier Homes' founder Mr. Jerry F. Wilson, is the CIO and head of CIS Financial Services of Cavalier Homes, Inc. Jay graduated from the University of Alabama at Birmingham in 1990 with a B.S. in Finance. During his school years, Jay took as many classes in computer science as allowed by his curriculum. As soon as he graduated, Jay joined his father's business, Cavalier Homes, and was appointed as Director of the financial services branch for the company. In August 1991,

---

<sup>1</sup> Graduate Research Assistant, Kai Pan prepared this case under the supervision of Dr. Larry R. Barrow --- AIA, as a basis for class discussion rather than to illustrate either effective or ineffective handling of information technology and professional practice development  
Copyright © 2002 by the Mississippi State University, School of Architecture - Digital Research and Imaging Lab (DRIL) No part of this publication may be reproduced, stored in a retrieval system, used in a spreadsheet, or transmitted in any form or by any means - electronic, mechanical, photocopying, recording, or otherwise - without the permission of the Mississippi State University - School of Architecture - Digital Research and Imaging Lab (DRIL).

Jay founded the Cavalier Acceptance Corp. (now CIS Financial Services) to originate and purchase manufactured home loans. Jay is a very aggressive man in adopting new technology. With his computer background, Jay helped the company build the first intranet system in North Alabama in 1992. One year later, Cavalier's internal email system was built and brought into use. In 1996, Jay was appointed as the CIO of Cavalier Homes and in charge of the company's IT issues.

By 1998, when the industry was experiencing historical rapid growth, Jay and his team had realized the inefficiency of Cavalier's entire operation. They knew they needed new technology to survive in the competitive market.

Jay and his team finally selected mySAP as Cavalier IT project's backbone. This e-business software is developed by SAP, a Walldorf, Germany based Software Company. mySAP E&C can support the full range of business processes, from specification and design to construction and manufacturing, approval, and maintenance. It can be used as the tools of e-business to collaborate with partners, suppliers, contractors, and customers.

Although the SAP project was a little more than 50% implemented, its benefits were already apparent. Now, Jay was thinking about another future project. The goal of this project would be to share electronic design documents between Cavalier's operations in 7 states through the internet. Jay stated: *"The vision could extend to exposing the site drawings to our service trucks in the field one day which would vastly increase our ability to make our customers happy."*

Jay believed that new technology was the key to open the door to Cavalier's future. He believed the goal could be achieved with the foresight of CEO, Mr. David Roberson, who was appointed following the death of Jay's father. Jay added: "To date, we are the only manufactured home producer to successfully deploy a full blown ERP (Enterprise Resource Planning) system. Our CEO is very aggressive and forward thinking compared

to his peer group in the industry. I can honestly say that this thinking is making a massive difference in our ability to perform in a terrible market condition.”

Questions for Discussion:

1. What are Cavalier’s development strategies?
2. What is the biggest challenge Cavalier is facing?
3. Is identity a problem for the company?
4. What is Cavalier doing to rationalize its whole business process?
5. What was the purpose of installing the SAP system?
6. How has IT affected Cavalier’s competitive ability in the MH market?
7. What is the current condition of CAD/CAM technology in Cavalier Homes?
8. What is the current extent of Research & Development at Cavalier Homes?



### Cavalier Homes, Inc.

The following is a quote from the official website of Cavalier Homes, Inc:<sup>2</sup>

“The company was founded in 1984 by Mr. Jerry F. Wilson and opened its first manufacturing facility in Addison, Alabama. The company first became publicly traded in 1986 on the American Stock Exchange under the symbol "CXV". During 1987, the Company acquired six operating plants owned by Brigadier Homes, Inc. In February 1993, the Company acquired Homestead Homes, Inc., a privately-held company located in Cordele, Georgia. During 1993, the Company also expanded its Hamilton, Alabama production facility and in May of 1993 the Company opened an additional plant in Addison, Alabama. During 1994, the Company opened additional manufacturing facilities located in Fort Worth, Texas and Winfield, Alabama and in October of 1994 the Company acquired Astro Mfg. Co., Inc., a privately-held company located in Shippenville, Pennsylvania. On December 4, 1994, the Company began trading on the New York Stock Exchange under the symbol "CAV". In January of 1996, the Company acquired Riverchase Homes, Inc. located in Haleyville, Alabama. In December 1997, the Belmont Homes, Inc., whose shares were traded on The NASDAQ National Market under the symbol "BHIX", became a wholly owned subsidiary of the Company. Currently, the Company operates twenty-three home manufacturing facilities located in seven states. In 1991, the Company formed Cavalier Acceptance Corporation to purchase retail installment sale contracts for manufactured homes sold through the Company’s exclusive dealer network. During 1994, the Company formed Quality Certified Insurance Services to sell various insurance products to retail purchasers of the Company’s homes and to offer commercial insurance products to its exclusive dealers.”

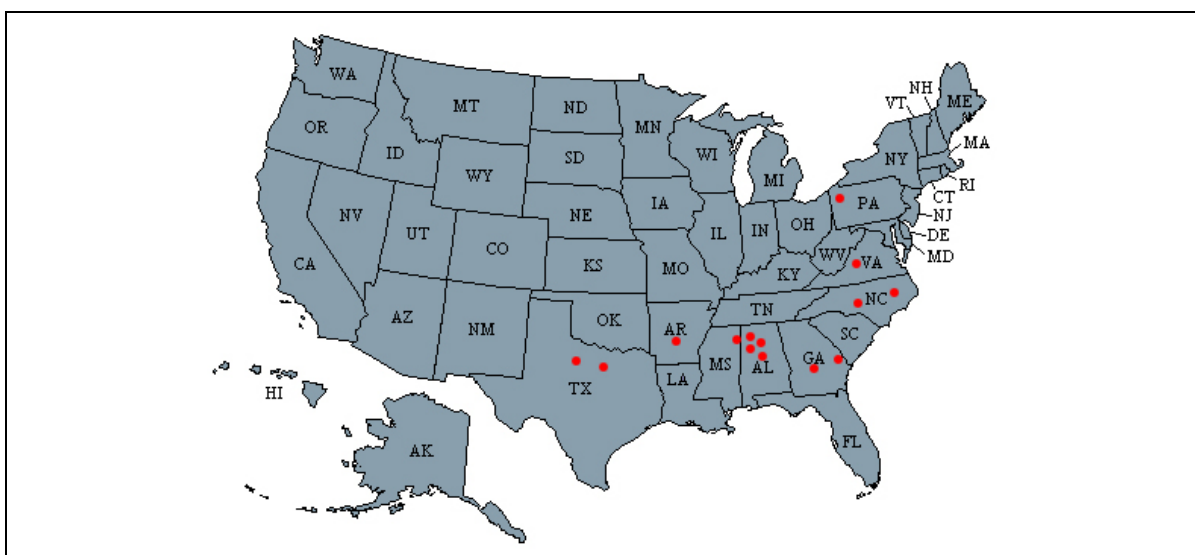

Figure B.1 The 14 facilities Cavalier ran in 2001

<sup>2</sup> <http://cis.cinfosystems.com/cis/salesservice/cavmfg/CH00/web/history.htm>

Cavalier Homes is a leader in the manufactured housing industry, especially relative to the use of Information Technology (IT). The company's business covers design, production, sales, finance, and insurance of manufactured homes. Cavalier experienced rapid growth during the 1990's until the advent of the recession. In fiscal year 2000, Cavalier Homes ranked 6<sup>th</sup> nationally in with 11,478 homes shipped (see Figure 23).

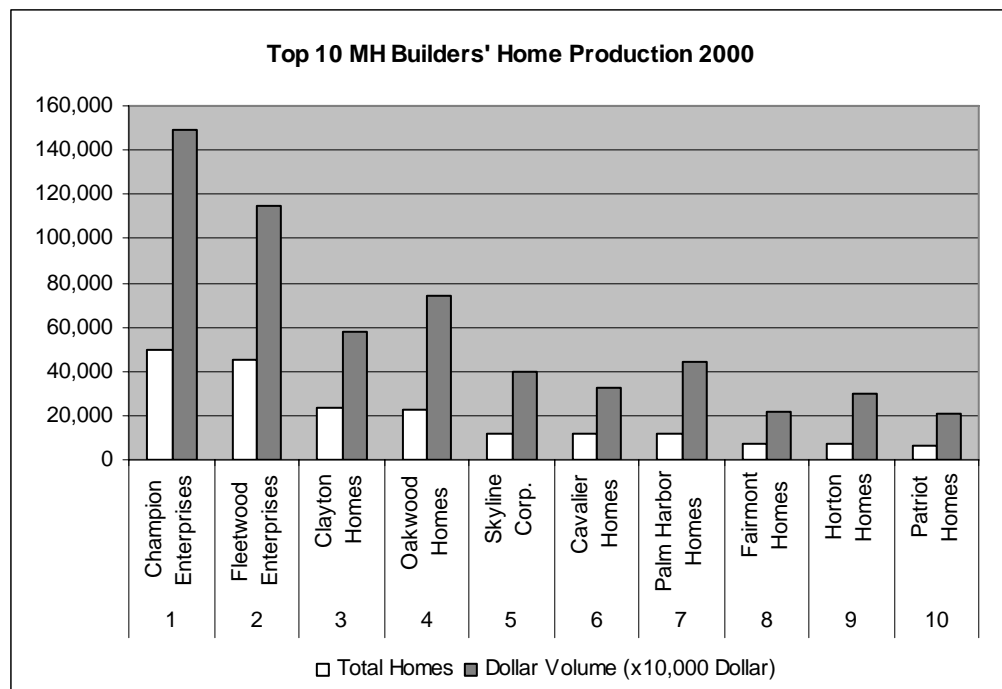

Figure B.2 Top 10 MH builders comparison, 2000

In fiscal year 2001, Cavalier Homes posted a net loss of \$14 million on sales of \$364 million. In 2002, for the initial 26 weeks end in June 29, 2002, revenues rose 31% to \$201.6 million and the net income totaled \$1.2 million. Increased revenues are attributed to increased demand for multi-section homes, lower advertising expenses, and the implementation of SAP, which we will cover in the following section.<sup>3</sup>

<sup>3</sup> <http://biz.yahoo.com/p/C/CAV.html>

This e-business software mySAP is developed by SAP, Inc., a Walldorf, Germany based Software Company. mySAP E&C can support the full range of business processes, from specification and design to construction and manufacturing, approval, and maintenance. It can be used as the tools of e-business to collaborate with partners, suppliers, contractors, and customers.

### **The Manufacturing process in Cavalier Homes**

During a visit to Cavalier's Hamilton, Alabama manufacturing plant, the following Work Station (WS) "process" was observed.<sup>4</sup>

The entire housing unit assembled by passing through a series of assembly line Work Stations (WS) where a specific set of operations was performed. The well-trained workers remained stationary as the products moved pass them in various degrees of completion. Workers are highly task-specialized which leads to optimum speed and efficiency. The WS breakdown is as follows:



Figure B.3 The assembly line station breakdown in the Buccaneer Homes

<sup>4</sup> Larry Barrow and Kai Pan visited the Cavalier Homes Office and Buccaneer Homes Manufacturing Plant, a subsidiary of Cavalier Homes in Hamilton, AL for an interview of Jay Wilson and Rodney Pannell on 23 October, 2002.

WS 2 -- Floor wiring  
and plumbing



WS 3 -- Duct  
installation



Figure B.3 (continued)

WS 4 – Bottom board,  
floor installation and  
Floor Sanding



WS 5 – Tile and begin  
of interior plumbing



Figure B.3 (continued)



WS 7 – Interior  
Partition set #2



WS 8 – End Wall set,  
begin of interior  
electrical and left side  
wall



Figure B.3 (continued)

WS 9 – Right side wall set and side wall wiring



WS 10 – Ceiling set and exterior sheathing



Figure B.3 (continued)

WS 11 – Begin of  
Exterior Department  
and Top Insulation

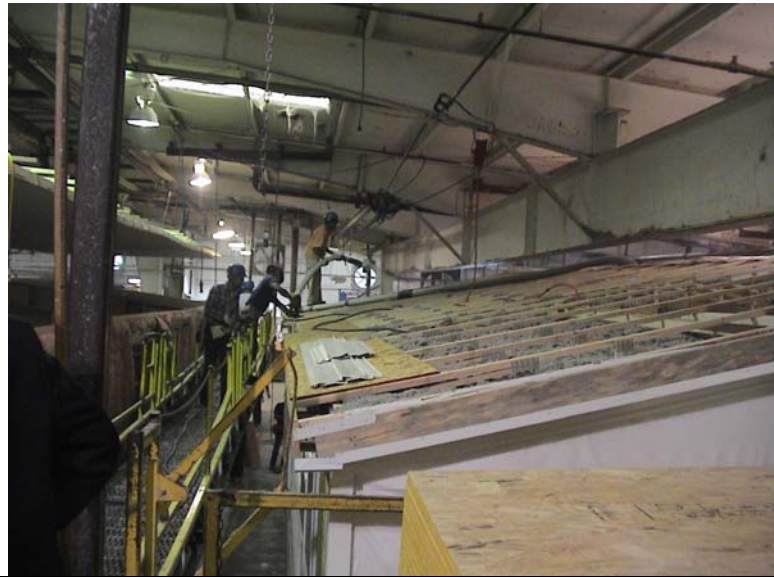

WS 12 – Top  
Sheathing and interior  
wallboard



Figure B.3 (continued)



WS 13 – The completion of Exterior, cabinet set and closet



Figure B.3 (continued)

Cavalier’s manufacturing technology has slowly evolved over time, additional WS have been added and the uses of pneumatic lifts and minimal CNC have been integrated into the process. Generally, the manufacturing process has seen very slow change; this is attributed to minimal investment in R&D and the continued use of traditional “stick built” methodology similar to “on-site” construction techniques.

### **Cavalier and Information Technology**

Cavalier shares similar manufacturing processes with other MH industry companies. Where Cavalier excels is in the use IT in their Business process.

The following diagram compares traditional MH builders with the implementation strategy of Cavalier Homes. The following information has been obtained from our visit to the Buccaneer Homes’ plant in Hamilton, AL, as well as survey among the top 25 MH builders, and information from obtained from the Manufactured Housing Institute’s website (see Figure 25).

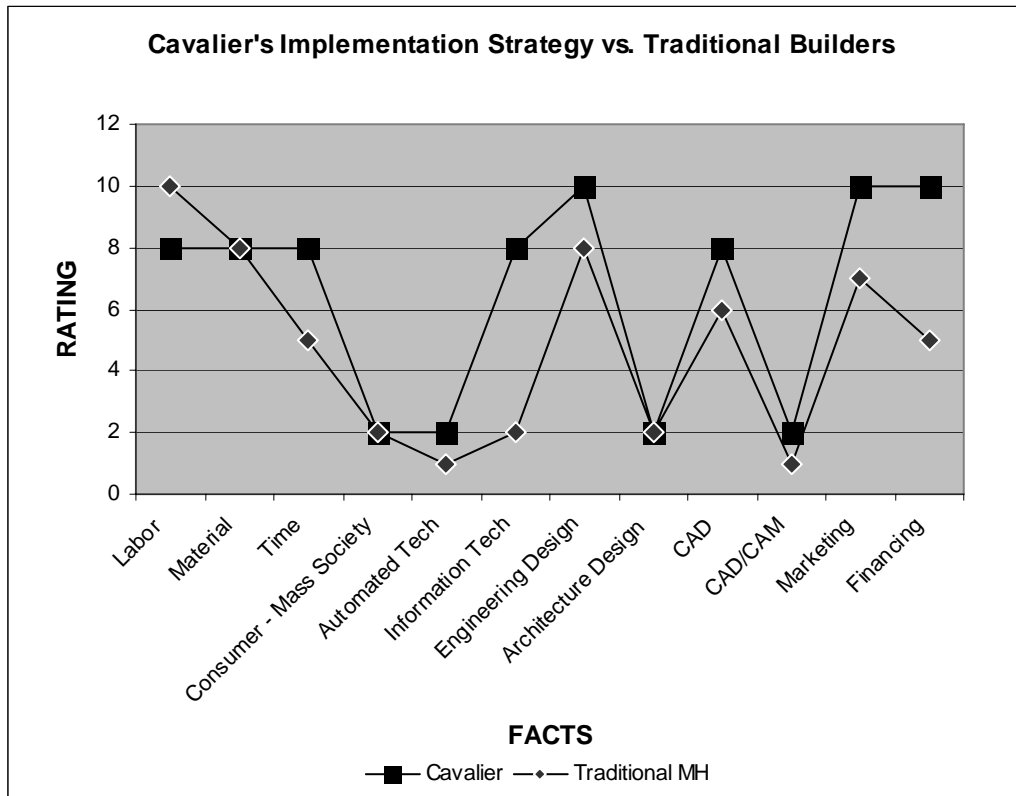

Figure B.4 Implementation Strategy, Cavalier vs. Traditional MH  
0=Low 10=High

The traditional MH industry is labor-intensive. Materials are transported from different suppliers all over the country and around the world. Time is a consideration, but not critical. Manufacturing automation and Information Technology are not widely used in the industry. Generally, the architects are not used for design; however, the structural engineering design is a very important phase in the manufacturing process because the HUD Code has strict engineering requirements for MH. Limited CAD technology is used in many companies, and CAD/CAM is used very minimally for small components and very limited cutting.

Jay Wilson wanted to build a self-efficient uniform-system for Cavalier's entire operation. Cavalier's 1992 efforts to offer financial and insurance services considerably

enlarged the company's customer base and assisted with stabilizing cash flow. IT was chosen as the backbone of Cavalier's process-standardization strategy.

In 1993, Cavalier built the first intranet system in North Alabama. In the same year, the company launched its own email system. In 1996, Rodney Pannell, the ERP System Engineer of Cavalier and Jay Wilson's right-hand man, joined the company. At the same time, Cavalier launched the SAP installation project, a part of Cavalier's ERP (Enterprise Resource Planning) System. Compared to the traditional MH industry, Cavalier Homes has several exceptions in its implementation strategy.

Cavalier Homes has installed a five-million dollar worth ERP software / IT system called SAP as the backbone of its administration system.

Currently, Cavalier is in the embryonic stage of moving to CAD technology standards. Approximately 22 staffs are responsible for the design and plans for Cavalier models. However, they are geographically disbursed in approximately 10 offices in 6 states. 11 of the "engineering" staffs utilize AutoCAD and 11 use DataCAD. Each office has been using their own local design and drafting guidelines. This has resulted in file sharing issues, communication breakdown, and the need to redraw and rework the plans to the "local" needs of the plant. Jay Wilson wishes to move to a common CAD platform (ADT) and develop a set of "Design and Drafting Guidelines" as-soon-as-possible.

With the installation of SAP and integration with the marketing and financing systems, Cavalier has improved its management operation systems dramatically.

After the installation of SAP, Cavalier Homes achieved its goals of process standardization, data-based decision making, reduced variation of home models, and reduction of raw materials. The limited implementation of an IT model has resulted in a large gain in efficiency, and stabilized cash flow, in a "down" economy.

Comparing the information and material flow charts before and after the installation of SAP (see Figure 26 and 27), we can see that before the installation, Cavalier's information system was a linear tree-like model. The information delivery speed in this system was comparatively slow and each facility had independent information system that did not allow knowledge sharing. This prevented assessment of corporate performance in a timely manner.

Before the SAP installation, Cavalier's material and products delivery system was a linear tree-like model. Resource deployment was irrational. Every facility had its own material warehouse, transportation facility, dealer system and service branch. There were redundant facilities, staff and work efforts. Cavalier's material inventory and dealer inventory was higher than its major competitors. The whole company's costs were out of control and the its entire operation was very inefficient (see Figure 28 and 29).

Following the installation of SAP, the information system had become a network model. Facilities could now share information and persons at the corporate level could obtain information from facilities, dealers, and even customers very quickly. Communication media became efficient and decision making processes became rational and timely. Cavalier Homes could view costs all the way through the value chain. The material/products delivery system became a collaborative network. The reduction of number of warehouses, transportation facilities and service branches considerably lowered Cavalier's inventory level, administration costs and service costs. Thus, SAP has made Cavalier operate efficiently and move toward a collaborative integrated business model. This is now allowing Cavalier to remain competitive.

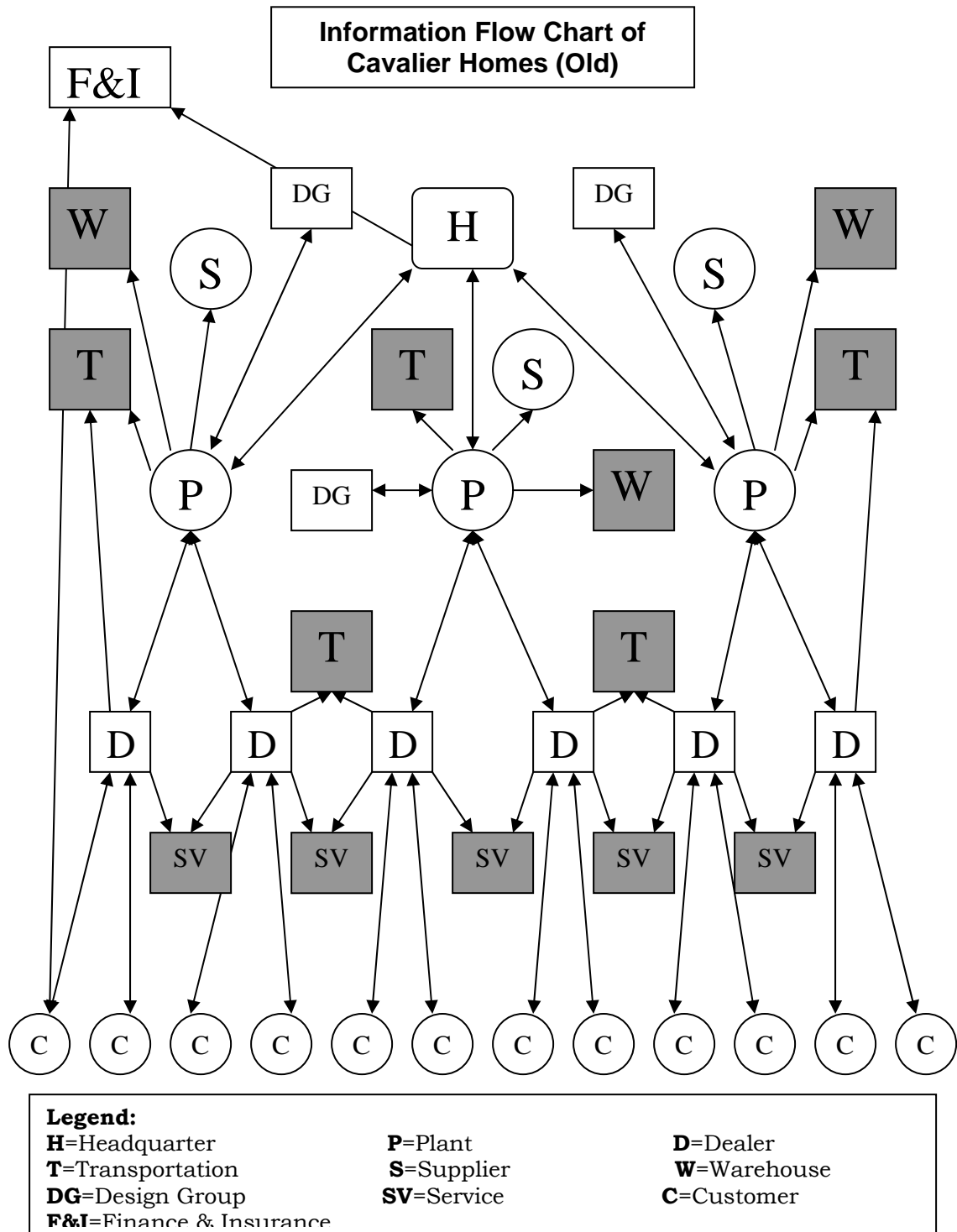

Figure B.5 Information Flow Chart of Cavalier Homes (Old)

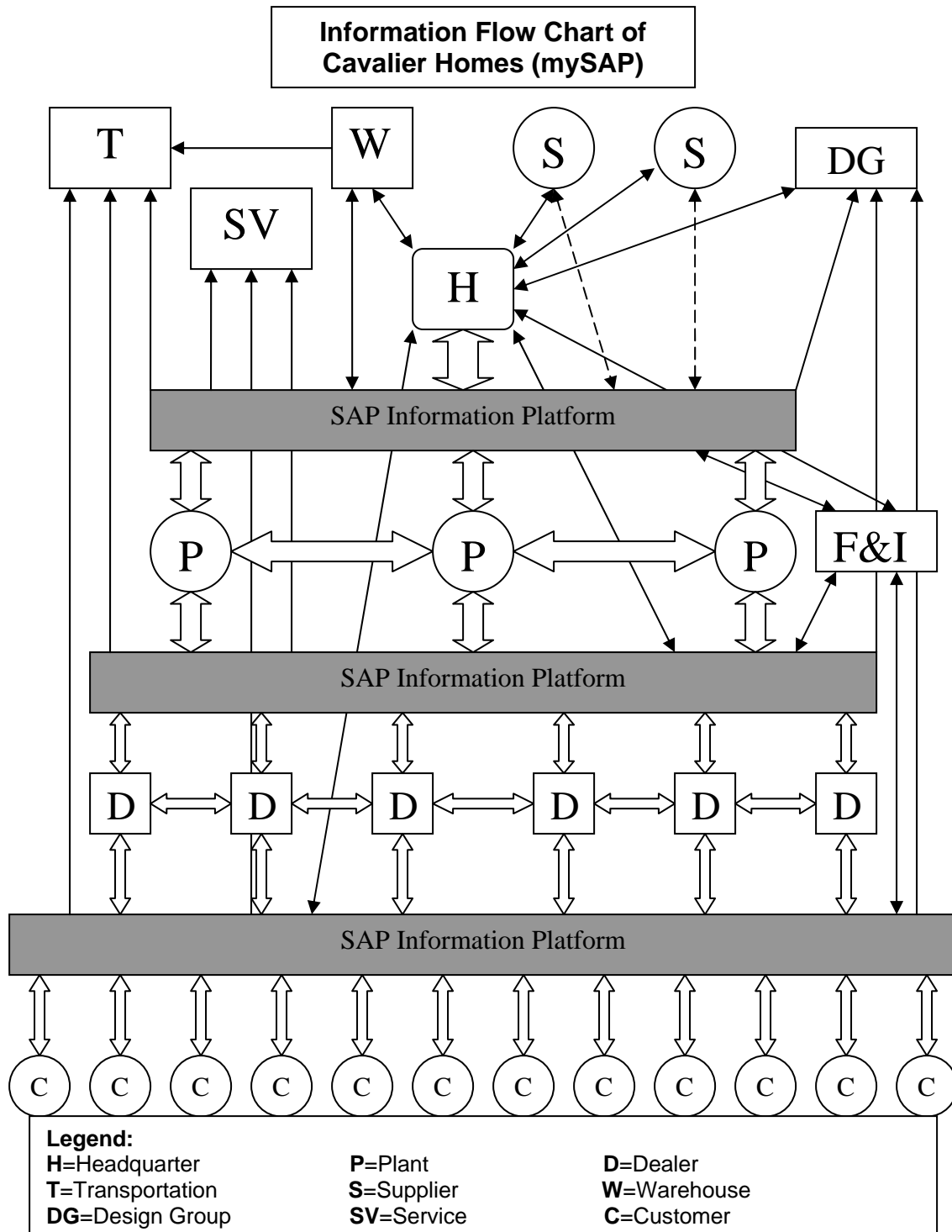

Figure B.6 Information Flow Chart of Cavalier Homes (mySAP)

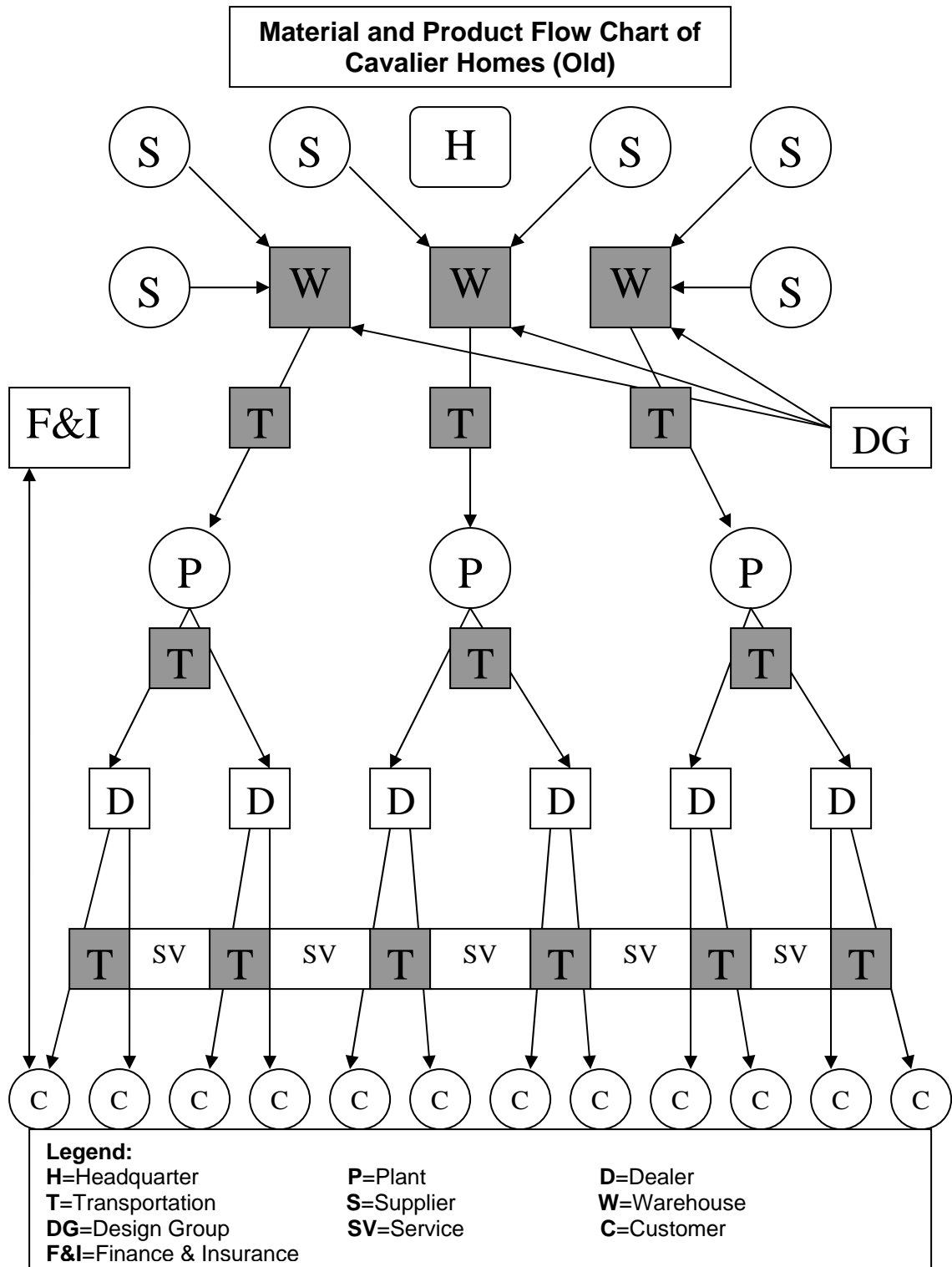

Figure B.7 Material and Product Flow Chart of Cavalier Homes (Old)

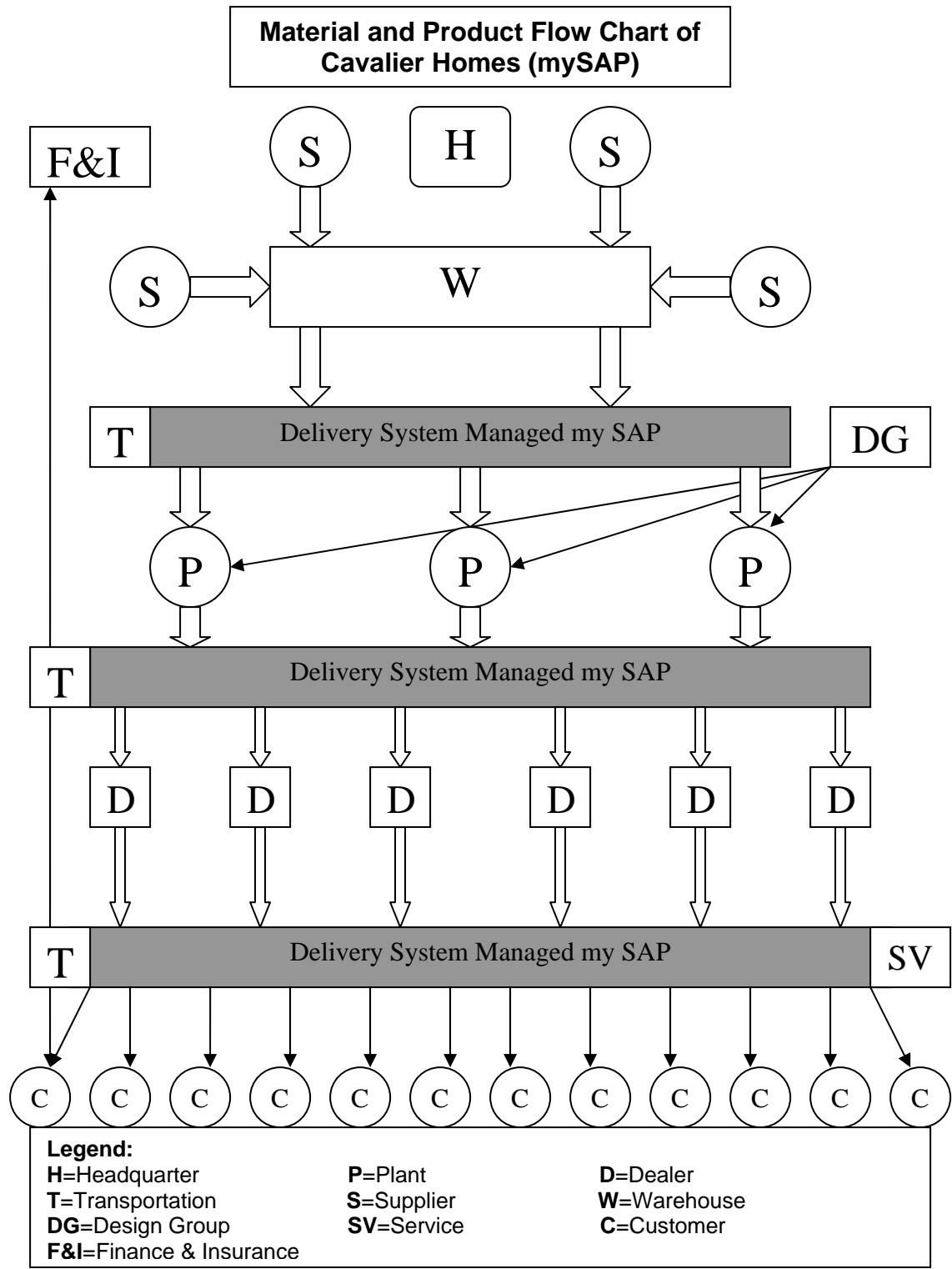

Figure B.8 Material and Product Flow Chart of Cavalier Homes (mySAP)



**Other Innovations by Cavalier**

Cavalier Homes is not only very aggressive in adopting IT into its operation process, but also design innovations. Hinged-roofs have been applied to make the roof pitches possible up to 9:12. Step-down (in same floor) design has also been used in various models to improve the quality of the interior space.

Based on the information provided by the SAP system, customers' requirements quickly feedback to Cavalier's headquarters, there the design group put everything that customers requested into a new model named the "Powerhouse". The "Powerhouse" model consists of 550 parts comparing with the 1800 parts previously. The powerhouse is \$5,000 cheaper than its major competitors due to its standardized design and reduced parts number. The standardization process cut the MH component list considerably reducing the number of components from 12000 to less than 1800. Quoting Jay Wilson," We could not achieve this without IT. We now customize the design per our customers' feedback. The 'powerhouse' has the same features with the same level products of our competitors, but its price is much more competitive."

The company's raw materials standardization has now been finished. The engineering (design and construction) lags behind and is now in the early planning stages of process standardization. Quoting Jay Wilson, "The design, planning and manufacturing process should start and finish using the same methodology, with a standard language and notations, "We are destroying old systems. The challenge for us is how we destroy old systems without destroy ourselves. Our goal is to enhance quality and lower costs—the win strategy." Jay added. "First company to do this wins!"

## **Interview**

This interview with Mr. Jay Wilson, the CIO of Cavalier Homes, will focus on the following four aspects.

1. What is the problem?
2. The impact of IT to Cavalier's whole business performance
3. Manufacturing technology (automated, CAD/CAM) in Cavalier Homes
4. Design expertise (especially architectural design) in Cavalier Homes
5. What is the implementation strategy of Cavalier Homes?
6. What is the perceived solution? Is there any timeframe?

The other person in this interview is Mr. Rodney Pannell, the ERP System Engineer and Jay's "right-hand" man. Rodney is a certified hardware/software engineer.

Rodney began work in the Buccaneer plant in 1989. In 1992 Rodney decided, with the help of his wife, to return to school. He chose to take Electronics, a two year course at a local Junior College. In 1996, Rodney joined Cavalier Acceptance Corp. (now CIS Financial Services), as the computer hardware engineer. Rodney began to study toward certification as a Compaq Accredited Systems Engineer as soon as he was hired. This was the beginning of his IT training. He took a couple of Microsoft Classes along with a week course from Compaq. He found that he could learn much more efficiently with self-study, which he used for the rest of his IT certification tests.

### **What is the problem?**

*Kai: We know that the whole Manufactured Housing industry is experiencing a hard time. What is the biggest challenge Cavalier facing? Is Identity a problem for Cavalier?*

*Jay: The problem for us now is the economy down blocked our development plan. We don't have enough money to continue our IT project. The most important work*

for us is to change people's attitude to new technology, new management model and new ideas. Identity is a problem for our industry. We are not trailers anymore. But there are still some zoning codes blocking MH out of communities. Changing MH's identity will bring us market expansion.

*Kai: What is the marketing strategy of Cavalier? Do you have any plan to broaden your market base? Will you compete for the site-built home market, or focus on traditional consumer group?*

*Jay: Our marketing strategy is to respond and fulfill our customers' requirements immediately. All of our efforts are to broaden our market base. A bigger market will be extremely different for us. We want better quality customers.*

*Kai: What is Cavalier's implementation strategy in its business activities? What will Cavalier rely on in the future market?*

*Jay: we want to build a standardized collaborative model for our business process. IT will be our backbone. We can't achieve it without IT.*

### **IT in Cavalier**

*Kai: When and why did you realize that Cavalier needed to adopt new technology in its administration system?*

*Jay: About 1998, when I realized that our costs were out of control and the entire operation was inefficient.*

*Kai: Why do you choose SAP as the backbone of Cavalier's IT administration project?*

*Jay: mySAP E&C gives us integrated, real-time information about schedules, costs, engineering, and our dealers -- everything you need to manage projects and processes at locations around the world. It can help us reduce costs, reduce risk and exposure, increase customer satisfaction, manage projects more effectively, expand your reach and increase sales.*

Kai: *what are the benefits the SAP system brought to Cavalier?*

Jay: The benefits include following:

- Reduced number of home models sold from over 800 to 140 and achieved prices of \$4000+ lower than the competitors in key segments.
- Improved market share from 4.6% to 7.6% increased home shipment by 15% while industrial shipment declined by 21%.
- Lowered raw material inventory levels from \$4.2 to \$2.1 million and improved turns from 1.0 to 4.7 per month at a key manufacturing facility; reduce dealer inventory by 10.4% to \$171 million.
- Lowered production hours per home by 20% and reduced production and administration workforce by 40%.
- Positioned the company for more efficient collaboration with suppliers.
- Achieve 100% enterprise-level availability of information
- Reduce production order time from two days to two hours
- Reduce material errors on truckload lists by at least 10%

(see Figure 30 to 39)

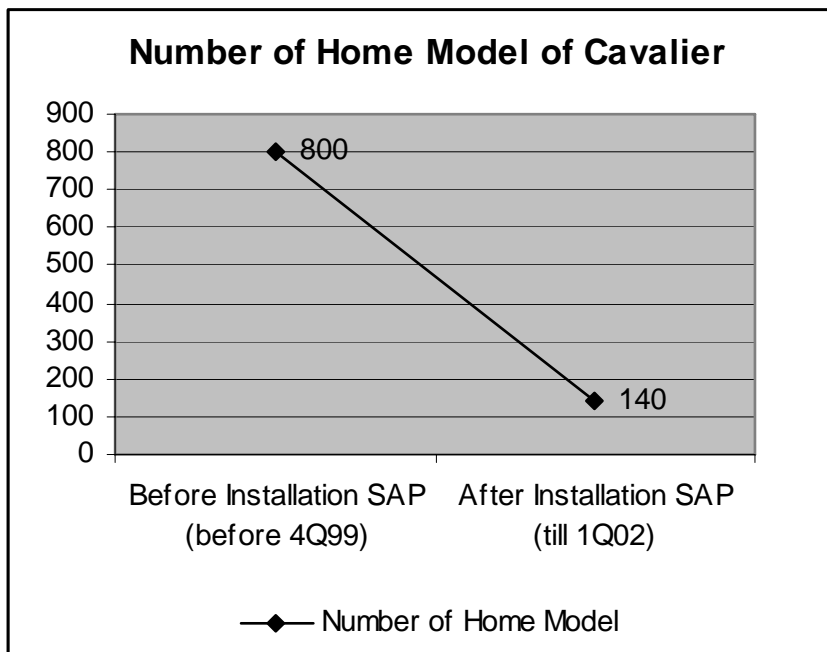

Figure B.9 Number of home models in Cavalier

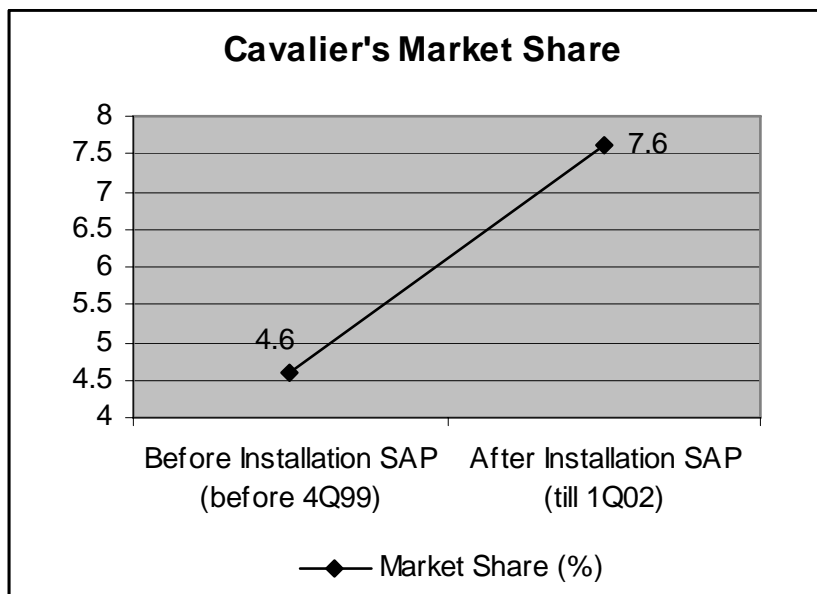

Figure B.10 Cavalier's market share

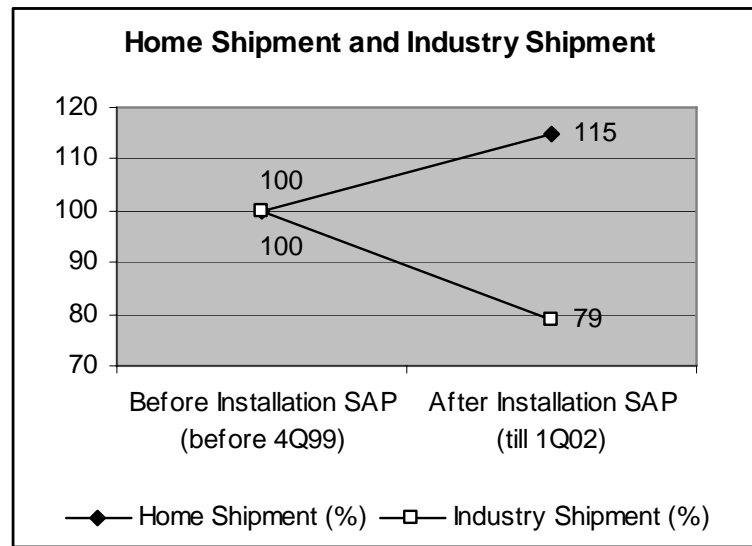

Figure B.11 Cavalier's home shipment and industry shipment

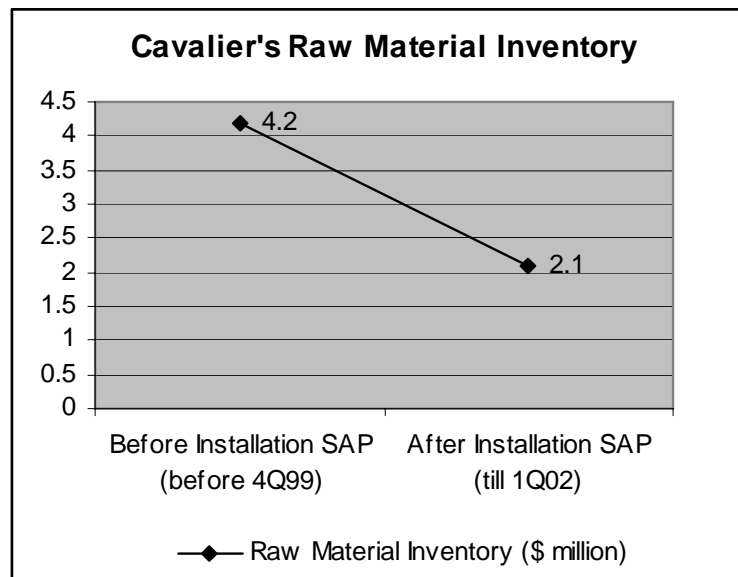

Figure B.12 Cavalier's raw material inventory

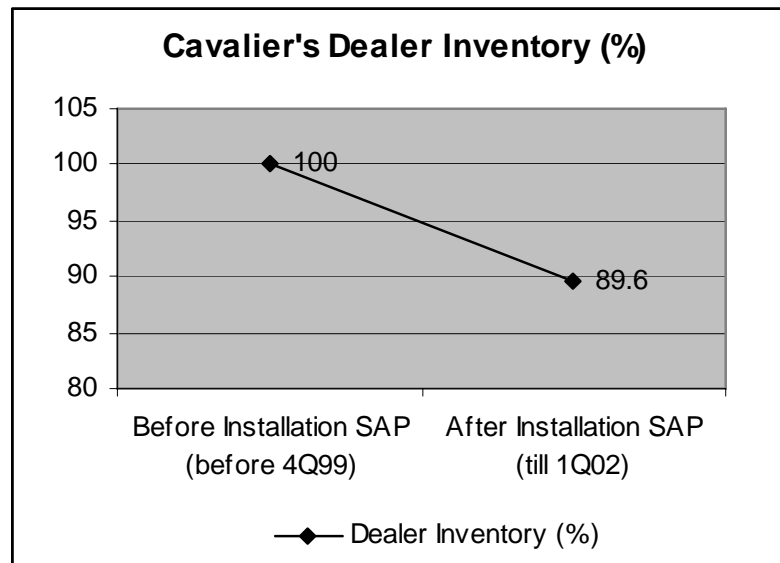

Figure B.13 Cavalier's dealer inventory

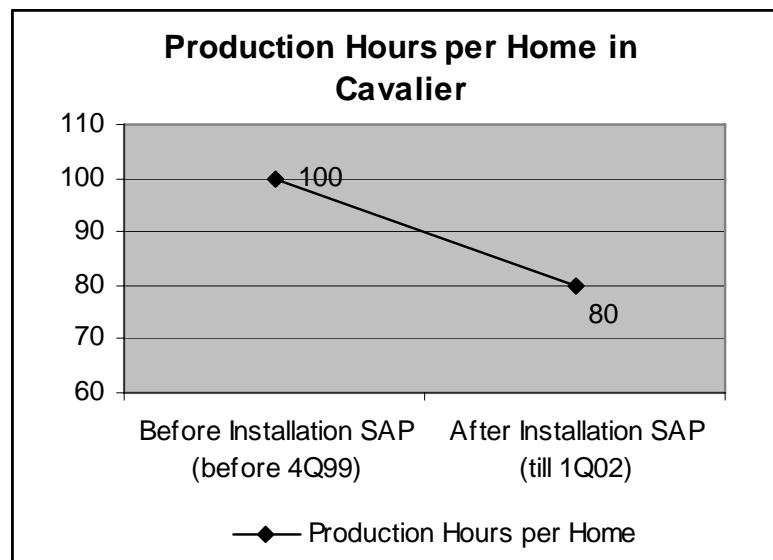

Figure B.14 Production hours per home in Cavalier

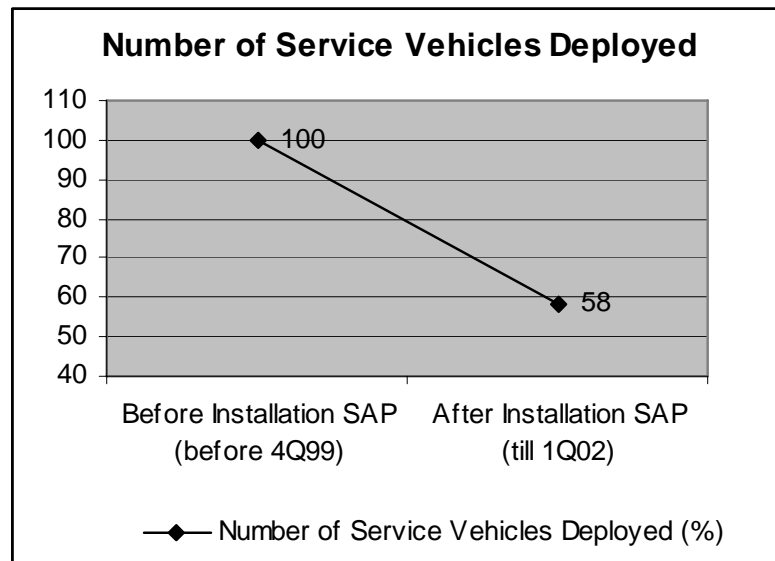

Figure B.15 Number of service vehicles deployed

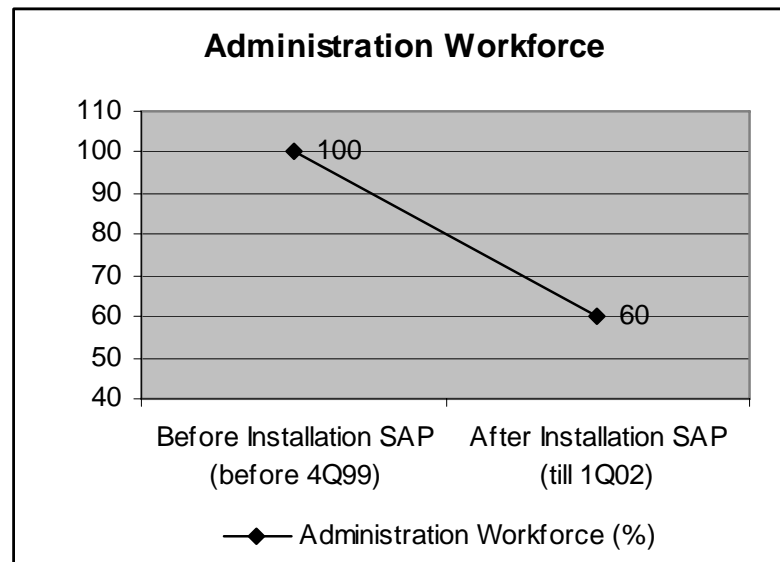

Figure B.16 Cavalier's administration workforce



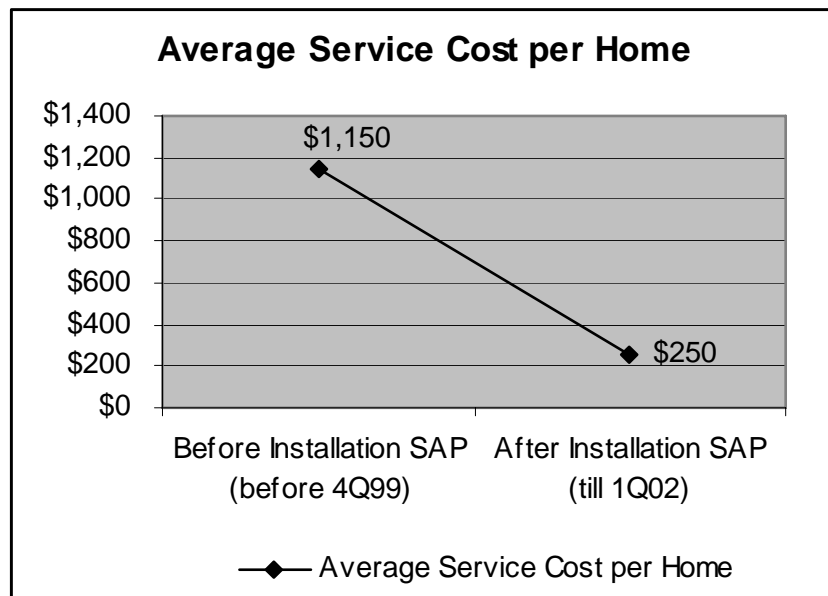

Figure B.17 Average service cost per home

Table B.1 Benefit of the SAP Project in Cavalier Homes

<b>Current Benefit of the SAP Installation Project in Cavalier Homes</b>		
<b>Results Achieved</b>	<b>Before Installation (before 4Q99)</b>	<b>After Installation (till 1Q02)</b>
Number of Home Model	800	140
Unit Price of Key Segments	P	P-\$4,000
Market Share (%)	4.6	7.6
Home Shipment (%)	100	115
Industry Shipment (%)	100	79
Raw Material Inventory (\$ million)	4.2	2.1
Dealer Inventory (%)	100	89.6
Production Hours per Home (%)	100	80
Cost of Service Operations (\$ million)	C	C-2.2
Number of Service Vehicles Deployed (%)	100	58
Average Service Cost per Home	\$1,150	\$250
Administration Workforce (%)	100	60

Kai: *That is exciting! It is no doubt that SAP system makes Cavalier be more efficient. Does the SAP system directly influence the quality of your products?*

Jay: Sure! Through the SAP system, we get valuable feedback from our customers. That directly helps us to enhance our product quality.

Kai: *How do you evaluate Cavalier's performance before and after the installation of SAP, comparing with the whole industry?*

Jay: Standardization and Collaboration vs. Inconsistency and Distraction. SAP makes our whole business process much more efficient. On the other hand, SAP destroyed our old business process. It is a big challenge for us to destroy the old system without destroying ourselves. The first step was successful.

Kai: *How do you evaluate the position of Cavalier in this industry in technology aspect?*

Jay: In respect to our peer group our company ranks "leading" in the adoption of new technology, even though we haven't picked up robotics at this point. To date we are the only manufactured home producer to successfully deploy a full blown ERP system. Our CEO is very aggressive and forward thinking compared to his peer group in the industry. I can honestly say that this thinking is making a massive difference in our ability to perform in a terrible market condition.

### **Manufacturing Technology**

Kai: *what kind of manufacturing technology are you using in Cavalier's plants?*

Jay: Our plant equipment ranges from "jig" systems that allow us to do things such as frame and deck a flooring sub-system or frame and build a sidewall on the home to simple hammers and nails.

Kai: *Has the installation of SAP influenced the manufacturing technology in Cavalier?*

Jay: Our manufacturing technology did not change much in the past decades. We use the typical assembly line techniques that is same as most other competitors.

Kai: *Has CAD/CAM technology been used in you plants?*

Jay: We have automated paint systems for our transportation chassis and things such as that. We are still very labor intensive and I would classify our manufacturing operations as low on the side of robotic production line automation.

Kai: *How do you envision the CAD/CAM's future (the robotic technology) in manufactured housing industry?*

Jay: Our CEO should be here talking with you about this topic. We are open to any new technology as soon as it becomes relevant to our process.

### **Architectural and Engineering Design in Cavalier**

Kai: *Please introduce the basic information about your design group. Are there architects in you design group?*

Jay: We have several mechanical engineers and draftsmen in our design group. We have not hired architects in the past --- this may change I think the transportation requirements limit the outer feature design in a "box" and throw architects out of this area.

Kai: *Do you have collaborative relation with any design firm or academic institutions?*

Jay: We have cooperation with those engineer experts in the University of Alabama, University of North Carolina and North Carolina State University.

Kai: *Do you think the outer appearance of MH has limited its ability to compete with site-built home? Do you think Cavalier needs do more to enhance its design quality in both architectural and engineering aspects?*

Jay: Sure, if we can enhance our products feature, we will expand our market share dramatically. We do want better quality customers. If you could make a factory-built home look the same as a 2,500 square feet site-built house, you will win the world.

Kai: *Do you have any project relating to design?*

Jay: Yes. This project is to standardize our engineering process. It is still in the idea stage. We utilize CAD systems for print design, and then translate the engineering prints into our SAP bills of material associated with that particular home. The issue is the ability to convert AutoCAD files to Data CAD files and share those electronic documents between our operations (7 states). We are pondering the use of our Intranet to create a site for indexing, searching and sharing our engineering print data. Our CAD systems will save the prints into tiff images (even though they are large they can be used nicely within the context of a browser) and then we can load them into the site. The vision could extend to exposing the site to our service trucks in the field one day which would vastly increase our ability to make our customers happy.

Kai: *Would you please envision Cavalier's future development in IT?*

Jay: Cavalier Homes expects to implement collaborative processes with the suppliers. This initiative will provide us with opportunities to further reduce raw material parts costs and offer better value to our customers. Also we expect to install mySAP Customer Relationship Management. This will allow us to market new home service, financial, and insurance products to our installed base of home owners. Such initiative will increase high margin service and financial product sales, and will better position Cavalier as a full service provider of manufactured homes.

## **Conclusion**

During the 1990's Cavalier experienced rapid growth, however by 1998 Cavalier's leaders realized their entire operation was very inefficient. They wanted to do something to change the situation. Supported by Mr. David Roberson, the new CEO, Jay Wilson

and his team selected SAP E&C as the backbone of Cavalier's administration reform project.

Although the project is only partially implemented it has brought considerable benefits to Cavalier. It makes Cavalier much more efficient in its marketing, manufacturing, purchasing and sales and IT has empowered Cavalier to perform exceptionally in considering the current "down" economy.

Cavalier Homes has an integrated business model compared to other MH companies. Cavalier has its own dealer system, finance facilities and insurance facilities. It also has close relations with research institutes and universities. All these make Cavalier much stronger than others, especially during the current recession. The cooperation with research institutes and universities allows Cavalier to access the new technology and "ideas" in a timely manner.

Cavalier has a very clear future development strategy. Cavalier wants to standardize its entire business process and build up collaborative systems for its entire operations. To date, Cavalier has finished its raw materials standardization project. The coming engineering standardization project will rationalize the company's engineering operation and allow its engineering group work collaboratively.

Cavalier Homes has aggressive leadership with foresight. This group is comparatively young and well-educated and is focused on computer technology. The CEO, Mr. David Roberson is 45 years old. The COO, Mr. Gregory A. Brown is 44 years old. The CIO, Mr. Jay Wilson is 36 years old, and Mr. Rodney Pannell, the ERP system engineer, 36. This group provided critical foresighted thinking to the company's development strategy. Jay Wilson stated, "The most important thing is a positive attitude toward new technology and ideas."

Table B.2 Summary of Cavalier Homes Inc. Case Study

<b>Cavalier Homes, Inc</b>	<b>Case Study - SUMMATION</b>
Keywords:	Manufactured Housing - Information Technology, Design, Efficiency
Protagonist:	Jay Wilson, Chief Information Officer, Chair of Financial Services
Objectives:	use of IT and design technology to improve the quality and efficiency and to be well positioned for the next cyclical upturn
Decisions:	How to apply technology and design to improve quality as well as lower costs.
Time Period:	mid 1990's to present
Revisions:	October, 2002
Project Reviews:	
Main Issues:	1) incorporation of IT in MH industry,
	2) administration structure change in the company,
	3) costs control changes,
	4) material purchasing and transporting changes,
	5) efficiency & profitability using IT,
	6) collaboration between operations
Innovations:	1) cost control and efficiency,
	2) information share, resource share
	3) broaden market base

APPENDIX C

TRAILERS, VITAL AFTER HURRICANES, NOW POSE OWN RISK AT GULF

**Trailers, Vital After Hurricane, Now Pose Own Risks on Gulf<sup>1</sup>****By ERIC LIPTON (NYT) 1176 words**

Published: March 16, 2006

PORT SULPHUR, La., March 11 - In its rush to provide shelter for victims of Hurricane Katrina, the Federal Emergency Management Agency has created a pressing new Gulf Coast hazard: nearly 90,000 lightweight trailers in an area prone to flooding, tornadoes and, of course, hurricanes.

The risks of living along the coast inside what amounts to little more than an aluminum box are already obvious to Mitchell and Marie Bartholomew, whose travel trailer here in Port Sulphur, about 40 miles southeast of New Orleans, rocked so violently in a recent routine storm that they abandoned it for a hotel.

"It rattles, it rolls," said Mr. Bartholomew, 62, a retired boat captain, whose trailer sits between the Mississippi River and the slab where his home once stood. "It is like telling you to get out."

Government officials along the Gulf Coast and in Washington agree that the temporary housing, while better than a tent or emergency shelter, is far from ideal.

"They're campers," Gov. Haley Barbour of Mississippi told a Senate committee this month. "They're not designed to be used as housing for a family for months, much less years. The trailers don't provide even the most basic protection from high winds or severe thunderstorms, much less tornadoes or hurricanes."

With hurricane season less than three months away, Homeland Security Secretary Michael Chertoff said in an interview that he too was worried about the situation. Not

---

<sup>1</sup> New York Times, "Trailers, Vital After Hurricane, Now Pose Own Risks on Gulf", March 16th, 06



only are the trailers lightweight, they are often placed next to partly reconstructed homes and debris that can turn into dangerous projectiles when the wind picks up, Mr. Chertoff said.

Since the travel trailers used by the Bartholomews and others are intended to be portable, they are mounted on wheels so they can be pulled by large pickup trucks until, on reaching their destination, they are jacked up and mounted on concrete blocks. Designed initially for recreational use, the units -- 35 feet long, 8 feet wide and weighing about 6,000 pounds -- are much smaller, lighter and less expensive than so-called mobile or manufactured homes, which are typically emplaced permanently.

More than 87,100 families in Louisiana, Mississippi and Alabama are living in the FEMA trailers, while only some 2,300 are in the sturdier mobile homes.

FEMA ordered far more travel trailers than mobile homes after the hurricane because the trailers could be towed to a homeowner's property and quickly dropped into place. Being portable, they are not generally covered by building codes and not explicitly banned in flood zones.

For further security along the windy Gulf Coast, FEMA secured the trailers to the ground with steel straps that connect to four corner anchors, although many homeowners have installed their own trailers, in some cases without anchoring them at all.

The added security for the FEMA trailers means that while they may vibrate or rock in the wind, they should not be vulnerable to tipping over until winds exceed 75 miles per hour or so, said Mark C. Smith, a spokesman for the Louisiana Office of Homeland Security and Emergency Preparedness. That speed is typical during intense tropical storms, extremely severe thunderstorms and all hurricanes. (FEMA agrees that 75

m.p.h. should be the threshold for evacuation, although Eddie Abbott of Gulf Stream Coach, a trailer manufacturer, said he thought an anchored trailer would be stable at higher wind speeds.)

By comparison, new coastal homes must be able to withstand winds of up to 110 to 150 m.p.h., depending on location, said Gene Humphrey, an official in the Mississippi fire marshal's office.

The potential hazards with the trailers are obvious across the gulf region. In Myrtle Grove, La., north of Port Sulphur, FEMA trailers sit on the ground below houses that are suspended on stilts to avoid routine floodwaters that would swamp the trailers. Elsewhere, they have been installed just a few feet away from homes that remain ripped wide open from Hurricane Katrina.

Add wind, and the environment can quickly become treacherous. Jimmy Cappiello, a retired oil platform operator who now lives part time in a Port Sulphur trailer, saw sheet metal, trash, wood planks and even the carport from a nearby house flying during a recent storm. He waited it out in his pickup, which he felt was more solid than the trailer.

"I ain't taking no chances," Mr. Cappiello said. "I don't feel safe in it."

In early February, the New Orleans police reported that at least one FEMA trailer was ripped from its anchors when a tornado passed through. And last July, in Pensacola, Fla., a number of trailers installed after a 2004 hurricane were damaged or flipped when Hurricane Dennis hit.

Mr. Humphrey, from the Mississippi fire marshal's office, said he realized that many families wanted a trailer next to their damaged houses. But FEMA, he said, made a

mistake in installing the lightweight trailers, instead of the heavier mobile homes, in this high-wind zone on the coast.

"This is pretty serious," he said. "It never should have happened."

With so many trailers and damaged homes along the gulf, and with some levees weakened, local officials will most likely call for coastal evacuations more frequently this year, said Mr. Smith, the Louisiana official. "The key," he said, "is going to be trying to figure out how to word it so people don't get a false sense of security, but people don't panic, either."

Mr. Chertoff said he had already spoken with officials at FEMA and the Defense Department to make sure that federal agencies are ready if needed to help in evacuations.

"We are going to say, 'We want to see the plan, and we want to see what the capabilities are,' " Mr. Chertoff said. " 'And if you don't have the capabilities, we need to know that, because we are going to make sure we have those capabilities in place.' "

In recent weeks, some coastal cities, including Biloxi and Ocean City, Miss., have decided that when severe storms approach, they will open temporary shelters where people living in travel trailers or damaged homes can wait out the bad weather.

"We have to be on our toes sooner," said Ashley Roth, a spokeswoman for the Mississippi Emergency Management Agency. "The trailers are just not safe to stay in, in the event of severe weather."

Some trailer residents along the coast in Mississippi and Louisiana said they would not be reluctant to head for more solid shelter. "They won't have to tell me -- we will be moving out," said Daisy Lightell, 57, of Happy Jack, La., north of Port Sulphur, who

lives in a FEMA trailer with her husband. "Otherwise, we could end up in 'The Wizard of Oz.' "

Above all, officials want to discourage residents from trying to evacuate with their trailer in tow, a circumstance that could create an even worse hazard.

"I imagine there are going to be some people who consider it," said Jesse St. Amant, emergency preparedness director for Plaquemines Parish, La. "But I hope they think better of it. Trying to haul a travel trailer during an evacuation would be cumbersome and dangerous."

Photos: Not only are FEMA trailers vulnerable to storms, they are frequently placed next to debris that wind can turn into dangerous projectiles. (Photo by Ozier Muhammad/The New York Times)(pg. A1); Marie and Mitchell Bartholomew had to abandon a trailer during a recent storm. At right, photos of their home after Hurricane Katrina.; Paula Cappiello looking over the debris of her destroyed home from the FEMA trailer where she and her husband now live in Port Sulphur, La. (Photographs by Lee Celano for The New York Times)(pg. A24)

Map of Louisiana shows the location of Port Sulphur: "It rattles, it rolls," a resident said of his trailer in Port Sulphur. (pg. A24)