

STUDY ON SYSTEM TOPOLOGIES FOR ENHANCING POTENTIAL OF FUEL CELL SYSTEM

Stalin Kumar
M. Tech Scholar

Corporate Institute of Science and Technology Bhopal
India
stalinkumarmit@gmail.com

Sandhya Pandey
Assit. Professor

Corporate Institute of Science and Technology Bhopal
India
ssandhya.parashar@gmail.com

Abstract

Fuel cell is most promising power source for hybrid operation with conventional and non-conventional energy source. This is due to its operating temperature, power matching and remote application. The fuel cell based distributed generator (DG) source can be operated in combined with wind turbine, photovoltaic generation system, gas turbine and many more. The hybrid operation of fuel cell with conventional DG source may increase the reliability, power quality and system stability. This paper presents the review on hybrid operation of fuel cell with other conventional DG system in utility interconnected mode. In this, it is addressed that, the fuel cell and its hybrid operation with other power generation application are given. Also the various controlling techniques can be used for its optimum operation which are also mentioned

Keyword: Fuel cell (FC), Power quality, Harmony search (HS), Particle swarm optimization (PSO), Fuzzy logic

recently identified problem in a family of commonly used models in the literature. The problem involves the (erroneous) mixing of reversible and irreversible potentials in the computation of the cell output voltage. The present paper seeks to solve the problem by separating the irreversibility from the reversible (equilibrium) potential of the fuel cell. The solution is achieved by introducing a novel “Nernstian gain” term and establishing it as an irreversibility for the constant fuel utilization condition. A Nernstian loss term, somewhat akin in spirit to traditional fuel cell losses, is used to analyze the constant fuel flow operation. The remainder of this paper is organized as follows. A brief survey of previous work on fuel cell modeling is presented in Section 2. Section 3 describes the problem. Section 4 develops a model for the constant fuel utilization mode of operation of the cell. The constant fuel flow mode is modeled in Section 5. Conclusions are drawn in Section 6.

I. INTRODUCTION

Fuel cells convert chemical energy into electrical energy and are fast emerging as one of the major alternatives to fossil-fuel-based sources of energy. Modeling is often an integral part of fuel cell research, spanning areas from new material investigation to system integration to control of the plant. Even though many models of fuel cells and fuel cell systems have already been proposed in the literature, new models continue to be developed, improving upon the state of the art. This paper presents an improved fuel cell model for two operating conditions: constant fuel utilization and constant fuel flow (with the constant fuel flow operation being analyzed in the context of two different modes for the oxidant—the constant oxygen flow mode and the constant oxygen stoichiometry mode). The need for a new model arose because of a

II. LITERATURE REVIEW

Mohamed I. Mossad et al. [1] this paper propose in the Fuel Cell (FC), as a type of new renewable energy sources grid-connected at Point of Common Coupling (PCC), is introduced in this study. This article presents the power quality improvement of the FC integrated to the power network through a chopper and an inverter using the conventional PI controller. Two PI controllers, tuned by three recent different evolutionary computing techniques namely Harmony Search (HS), Modified Flower Pollination Algorithm (MFPA) and Electromagnetic Field Optimization (EFO) methods are considered. The two PI controllers are used for driving the inverter connected the on-grid FC in order to govern the PCC voltage between the FC and the power network. These two controllers are

exploited to drive the power and the current regulators at different voltage sag and swell conditions.

M. Ramadan et al. [2] this paper aims at proposing a coupled system of hydrogen and solar energy. The solar thermal system is used as an energy source to supply the electrolyzer. The modeling of the FC and the Thermal Solar System (TSS) are comprehensively presented. A case study for a stand-alone system that supplies 3 kW in Beirut City is studied. Through the simulation results, the power over the year as well as the relevant number of mirrors needed to cover the power demand are properly calculated. For instance, 80 mirrors are needed in August 1st to provide 3 kW whereas 367 mirrors are required to provide the same load in January 1st.

Sandipan Patra et al. [3] This paper addresses the Power Quality (PQ) improvement in 3- Φ grid connected Photovoltaic-Fuel Cell based hybrid system using hybrid filter topology. In context of extraction of maximum power due to the uncertainty of solar insolation and temperature in the hybrid system, back stepping control is addressed for DC-DC boost converter. Space Vector Pulse Width Modulation (SVPWM) control technique is implemented for Voltage source inverter (VSI) for grid integration objective. Further the compensation of the distorted waveform at the point of common coupling (PCC) is accomplished by suitable controller design using hybrid filter. The series of simulation results in Mat lab environment and also a prototype system has been build and tested to verify the validity of the developed control methods which reflects the superiority of the design of controllers in the context of power quality enhancement.

Xiaosong Hu et al. [4] This paper proposes a Hermit wavelet embedded NeuroFuzzy indirect adaptive MPPT (maximum power point tracking) control of photovoltaic (PV) systems to extract maximum power and a Hermit wavelet incorporated NeuroFuzzy indirect adaptive control of Solid Oxide Fuel Cells (SOFC) to obtain a swift response in a grid-connected hybrid power system. A comprehensive simulation tested for a grid-connected hybrid power system (wind turbine, PV cells, SOFC, electrolyzer, battery storage system, supercapacitor (SC), micro-turbine (MT) and domestic load) is developed in Matlab/Simulink. The robustness and superiority of the proposed indirect adaptive control paradigm are evaluated through simulation results in a grid-connected hybrid power system testbed by comparison with a conventional PI (proportional and integral) control system. The

simulation results verify the effectiveness of the proposed control paradigm.

III. FUEL CELL MODEL

There are several types of fuel cells being developed for a variety of applications and these have been extensively discussed in the open literature. Unlike other variants, the SOFC is entirely solid state with no liquid components. Operation at elevated temperature is needed to achieve the necessary level of conductivity in the cell's solid electrolyte for it to operate efficiently. With an outlet temperature in the range of 900–1000°C, the efficiency of the cell alone is about 50 percent.

Typically the fuel cell system consists of SOFC generator modules in a parallel flow arrangement, with the number of standard modules being determined by the plant power requirement. The SOFC generator module embodies a number of tubular cells, which are combined to form cell bundle rows, several of which are arranged side by side to make up the complete assembly.

The high efficiency of the system means that less carbon dioxide is generated than in contemporary power plants. In addition, the fuel is oxidized electrochemically without any interaction with atmospheric nitrogen so negligible amounts of nitrogen oxide are discharged to the environment. Models for simulating fuel cell based plants have been developed by Bassett, Haynes, Paddles, Massado, Campanari, and Rao.

This paper provides a basic SOFC power section dynamic model used for performance analysis during normal operation. Some control strategies of the fuel cell system, response functions of fuel processor and power section are combined to model the SOFC power generation system.

The chemical response in the fuel processor is usually slow as it is associated with the time to change the chemical reaction parameters after a change in the flow of reactants. This dynamic response function is modeled as a first-order transfer function with a 5-s time constant. The electrical response time in the fuel cells is generally fast and mainly associated with the speed at which the chemical reaction is capable of restoring the charge that has been drained by the load. This dynamic response function is also modeled as a first-order transfer function but with a 0.8-s time constant.

IV. PARTICLE SWARM OPTIMIZATION

The particle swarm optimization (PSO) algorithm is a population-based search algorithm based on the simulation of the social behavior of birds within a flock. The initial intent of the particle swarm concept was to graphically simulate the graceful and unpredictable choreography of a bird flock [449], with the aim of discovering patterns that govern the ability of birds to fly synchronously, and to suddenly change direction with a regrouping in an optimal formation. From this initial objective, the concept evolved into a simple and efficient optimization algorithm. In PSO, individuals, referred to as particles, are “flown” through hyper dimensional search space. Changes to the position of particles within the search space are based on the social-psychological tendency of individuals to emulate the success of other individuals. The changes to a particle within the swarm are therefore influenced by the experience, or knowledge, of its neighbors. The search behavior of a particle is thus affected by that of other particles within the swarm (PSO is therefore a kind of symbiotic cooperative algorithm). The consequence of modeling this social behavior is that the search process is such that particles stochastically return toward previously successful regions in the search space.

V. HYBRID DG SYSTEM

The robustness problem of PV systems for parameter uncertainty can be alleviated by its integration with other energy sources, such as with an FC to form an HS. Further, the sluggish response of an FC can be improved by combining it with a BESS so the whole system can provide a continuous and constant power supply to a DC bus. A VSI is connected to invert the DC voltage into three-phase AC, which is further connected to the grid. At the PCC, the linear and non-linear loads are connected. A hybrid filter is also connected at the PCC to compensate the source voltage and current, providing quality power to the grid.

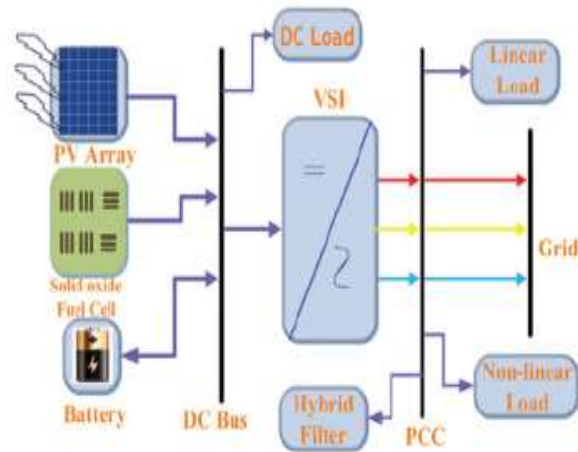

Figure 1. Proposed HS.

VI. HYBRID FUEL CELL WITH PHOTOVOLTAIC SYSTEM

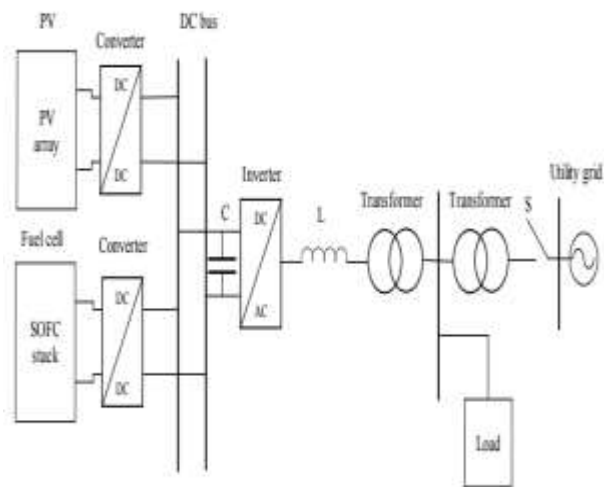

Figure 2 Hybrid solar and fuel cell system

The hybrid fuel cell and photovoltaic based DG system is shown in the Fig 4. In this, the system consist of proton exchange membrane fuel cell along with PV system are integrated at common DC link through the power converter. The PV system and PEMFC are modelled for the non-linear voltage sources. These sources are connected to the DC/DC converters which are coupled at the DC side of an inverter. In this, the hybrid system includes the PV is main source of power generation and it is only during the power generation is only during a day time which is intermittent and is compensated by the fuel cell. The power generated by this system is connected to the utility grid or load through power electronics interfacing and power transformer.

VII. CONCLUSION

In this paper, the fuel cell based hybrid DG system has been discussed in combined with other co-generation system. In this, it is ascertained that the fuel cell can use the application with other generation system. Different types of fuel cell and their application with renewable and nonrenewable generation system has been discussed. Among the different fuel cell, the most promising SOFC and its application with gas turbine generation system has found to be most effective. From the overall literature review, the SOFC and MTG system is the most promising source of DG system.

REFERENCES

- [1] Mohamed I. Mossad , H.S. Ramadan “Power quality enhancement of grid connected fuel cell using evolutionary computing techniques” DOI: 10.1016/j.ijhydene.2018.02.001 March 2018.
- [2] M. Ramadan, Mahmoud Khaled “Modeling and sizing of combined fuel cell-thermal solar system for energy generation” DOI: 10.1016/j.ijhydene.2016.08.222 September 2016.
- [3] Sandipan Patra, Ankur “Power Quality Improvement in Grid-connected Photovoltaic–Fuel Cell Based Hybrid System Using Robust Maximum Power Point Tracking Controller” DOI: 10.1080/15325008.2015.1082680 October 2015.
- [4] Xiaosong Hu, Editor “Adaptive control paradigm for photovoltaic and solid oxide fuel cell in a grid-integrated hybrid renewable energy system” volume 12(3): e0173966. 2017.
- [5] Aki H, Wakui T, Yokoyama R. Development of an energy management system for optimal operation of fuel cell based residential energy systems. *Int J Hydrogen Energy* 2016; 41:20314e25.