

Review

Development of an Intelligent Quality Management System for Micro Laser Welding: An Innovative Framework and Its Implementation Perspectives

José Luis Velázquez de la Hoz *  and Kai Cheng *

College of Engineering, Design and Physical Sciences, Brunel University London, Uxbridge UB8 3PH, UK

* Correspondence: joseluis.velazquezdelahoz@brunel.ac.uk (J.L.V.d.l.H.); kai.cheng@brunel.ac.uk (K.C.)

Abstract: Laser micro-welding manufacturers face substantial challenges in verifying weldment quality, as the industry and applications are requiring increasingly the miniaturization and compactness of products. The problem is compounded by new stringent demands for personalized products at competitive, low costs and the highest quality levels. High-pressure equipment manufacturers, in particular, rely on ISO 3834:2021 to assure and demonstrate best welding practices but also to manage risks associated with liability issues. ISO 3834:2021, like all conventional quality management systems, offers a one-dimensional, quasi-static overview of welding quality that may fail to deal with these new challenges and underlying complexities required to deal effectively with process variability. This paper presents a framework for welding companies to integrate horizontally their suppliers and customers with their processes and products, which are also integrated vertically in the context of Smart Manufacturing or Industry 4.0. It is focused on the development of a smart quality management system for intelligent digitization of all company manufacturing and business processes. Furthermore, an innovative data-based welding quality management framework is described for laser micro-welding applications and their implementation perspectives. The research is driven by an inductive methodology and based on a seamless integration of engineering-oriented heuristic and empirical approaches that is appropriate for intelligent and autonomous quality management, given the lack of research in this niche, but increasingly important topic area.

Keywords: laser micro-welding; in-process quality monitoring; welding quality; Industry 4.0; end-to-end integration; value chain networks



Citation: Velázquez de la Hoz, J.L.; Cheng, K. Development of an Intelligent Quality Management System for Micro Laser Welding: An Innovative Framework and Its Implementation Perspectives. *Machines* **2021**, *9*, 252. <https://doi.org/10.3390/machines9110252>

Academic Editor: Angelos P. Markopoulos

Received: 26 September 2021
Accepted: 22 October 2021
Published: 26 October 2021

Publisher's Note: MDPI stays neutral with regard to jurisdictional claims in published maps and institutional affiliations.



Copyright: © 2021 by the authors. Licensee MDPI, Basel, Switzerland. This article is an open access article distributed under the terms and conditions of the Creative Commons Attribution (CC BY) license (<https://creativecommons.org/licenses/by/4.0/>).

1. Introduction

Micro-fabrication in general, and micro laser welding specifically, have gained popularity in recent years as a result of a resolute interest in developing miniaturized and compact products. Micro- and nano-manufacturing have become a key value-added enabling technology for modern advanced manufacturing [1]. Laser micro-welding is a manufacturing process used in high-value engineering industries to join parts of very small size, typically in the tens of microns, using coherent laser beams. Laser micro-welding is when the weld depth and bead are below one millimeter [2]. Laser micro-welding occurs when the adhesion and the cohesion forces dominate the gravitation forces that are normally unbridled at macro welding [3]. Next to making possible very narrow, accurate welds, the heat-affected zone (HAZ) is significantly smaller, favoring both mechanical and chemical properties preservation. Lasers can produce weldments with a large depth-to-width ratio and aesthetically superior finishes, while their large energy density brings about welded products with minimal deformation or shrinkage. Steels, stainless steels, nickel-based alloys, but also more exotic materials like titanium, and palladium can be laser welded. Highly reflective materials like copper, silver, and gold have been successfully welded with this process as well. In addition to welding, lasers are also used for cutting, drilling, soldering, brazing, 3D printing, and even for medical and cosmetic applications.

Driven initially by the automotive industry, many others such as heavy machinery production, aerospace, medical devices manufacturers, high-pressure precision instruments, jewelry, plastic injection mold makers, electronics, and dental laboratories, etc., have been quickly adopting it and developing further both the technology and its applications.

Undetected welding defects in industries, like medical, automotive, or high-pressure vessels/containers, may result in unacceptable economic losses and in engineering consequences. Thus, manufacturers must exert due diligence to assure the required product quality, which implies tight controls before, during, and after welding. These measures are often prompted by constricting legislation and by an organizational commitment to comply with industry standards. The research presented in this paper attempts to address the difficulties encountered by practitioners while assessing the quality control for laser micro welded high-value engineering products, aggravated by the obstacles to both finding the appropriate legal provisions to back up welding activities and by an understanding of the underlying intricate engineering science imbedded in micro laser welding. Therefore, with the focus placed on this high-pressure instrumentation manufacturing industry, and particularly on microfluidic instruments and applications, this paper shall first contend that the current methods for quality assurance and control of laser micro-welding are often ineffective at least to some extent.

Furthermore, existing welding quality management systems, such as ISO 3834:2021 [4], coined as the golden welding quality management standard, are understood to be a legacy of traditional manufacturing eras, like mass production, when customer requirements were uniform and known ahead. As the market has intensified its variability, digitizing these quality management systems can enhance its utilization and its value for all industry participants. Industry 4.0 is expected to help challenge and eventually eliminate all orthodoxies within laser micro-welding quality evaluation and practices, by in-process data monitoring and analysis, and thus improving the process tracking and tracing capabilities and the process transparency. However, this new manufacturing era may bring along as well new challenges, such as the unprecedented product customization levels and/or the complete value chain integration, that will increase the complexity of laser welding activities in certain high-value industries.

It is not the intention of this paper to be an exhaustive survey of smart welding quality management systems but to initiate a discussion and stir the debate among specialists. The article is written using an inductive methodology, capitalizing on the industrial experience of the authors, given the absence of research in intelligent quality management systems in the Industry 4.0 context [5,6]. Conventionally, quality management relies more on empirical–heuristic and inductive approaches rather than being theoretical–analytic and deductive [7]. The inductive approach proposed by this paper consists of three stages. Firstly, observation of facts experienced by both welding engineers and welding manufacturers alike. In a second stage, patterns are unraveled by pointing out limitations in the current welding quality management system to meet new requirements and examining available literature in an innovative, interdisciplinary manner. Finally, a new laser micro-welding framework for mechanized and automated processes is further proposed and developed, and its implementation perspectives are investigated and explored.

2. Industrial Standards and Laser Micro-Welding

2.1. Regulatory Environment

The European high-pressure equipment market is heavily regulated. Manufacturers that supply vessels, containers, piping, and auxiliary products like valves, pumps, flow meters, or heat exchangers, having a maximum allowable pressure greater than 0.5 Bar(g) must comply with the Pressure Equipment Directive (PED) (2014/68/EU) [8]. Adopting this directive involves addressing all Essential Safety Requirements (ESR), detailed in its Annex I. These requirements can be satisfied by complying with the so-called harmonized standards, typically ISO standards describing the requirements involved in design, manufacturing, testing and inspection of these high-pressure products. For instance, harmonized

standards include EN 13445 [9] for pressure vessels applications and EN 13480 [10] for piping systems. The vast majority of high-pressure equipment falls under either one or the other.

The PED Annex I categorizes the various levels of risks in terms of severity first pressure vessels and then for piping. Category I, thus, contains the safety rules for the equipment posing the lowest risks to manufacturer personnel, clients, users, and society in general while Category IV details how to mitigate the risks associated with the largest possible risks. High-pressure equipment risk can become characterized in any of these categories by the type of equipment (either vessels or piping), the state of the fluid (either gas or liquid, albeit gas being more dangerous), and the fluid classification. Group I encompasses all dangerous substances as contemplated in the EU Regulation of Dangerous Substances [11] and Group II, and all the rest.

There is an additional Risk Category, known as SEP (Sound Engineering Practice), which details Art 4.3 of the PED, and it is associated with a group of products having operational and manufacturing risks below those of Category I. This is an especially important category for laser micro-welding and other high-density joining technology used in micro-manufacturing. Typically, devices under this risk category, even though they can operate at large pressures (well above 100 Bar), they are considered a lessened risk, as the potential energy they can store is smaller given its minuscule dimensions. However, although the risk indeed may be lower, the economic damage should still be considered if the welds failed. Similar concerns may be present in other parts of the world where different regulatory and legal frameworks may apply.

2.2. Welding Best Practices Adoption

If a product falls out of the high-risk pressure equipment categories, the manufacturer may still choose to conform to welding standards, to manage risks for both the organization and its customers. Adopting a welding standard like ISO 3834:2021 is enticing to manufacturers to counter for costs of poor quality, besides demonstrating welding best practices implementation. There exists an additional potential cost, however, that firms cannot ignore, the liability associated with poor quality products. The EU product liability law issued in 1985 lays down the basis for manufacturers' responsibility on defective products, unless "the defect could not be detected by the state of the art in science and technology at the time the company brought the product into circulation" or "the defect was due to the compliance of the product with mandatory regulations issued by public authorities" [12]. Thus, endorsing ISO 3834:2021 provides a widely accepted method to demonstrate the ability to meet both customer requirements and conformance to standards and directives, all attested by a Notified Body endorsed documentation.

ISO 9001 suggests that special processes should be called upon when quality cannot be readily assessed [13]. Welding is one of such cases, and to overcome this hurdle, quality needs to be built into the product [14] and verified afterwards either by destructive examination (examining a number of parts selected randomly) or by non-destructive examination like radiography, penetrant testing, visual inspection, etc., which will not improve the quality of the product. ISO 3834:2021 describes not only how to build quality in welding, per ISO 9001 methodology, but also how to align the quality of products, processes, and the overall system involved in the welding process, including equipment, welders, suppliers, and endorsing agencies.

There are further requirements like material certificates (attesting materials chemical compositions by original manufacturers), traceability (linking wetted parts to these certificates and to welders and approved processes), certification of welders (connecting welders to their certified ability to produce certain welded parts), or process qualification (demonstrating the soundness of a welding process to result in the specified weldments). They help manufacturers manage the risks of accidents during and after fabrication [15]. ISO 3834:2021 requires documentation of every process including inputs, outputs, process

owners, and customers [16]. The standard also places high responsibility on personnel from welding coordinators, inspectors, welders, and even internal assessors.

Additional aspects covered in ISO 3834:2021 are the review of requirements and an internal technical review of customer's requirements, and subcontractors management including quality, welders, personnel for measurements and control, non-destructive testing, welding equipment, welding techniques, storage and maintenance of additional materials like welding fillers, heat treatment after welding, measurements and control, nonconformities and corrective actions, calibration and measurement equipment validation, identification and traceability, and quality records [17–20]. It is implemented on a voluntary basis, and, again, its completion is certified by a Notified Body.

3. Industry 4.0 and Quality Control for Laser Micro-Welding

These techniques and methods described above are widely used to design, manufacture, inspect and test welded products, which have been highly effective for mass production. Then, the customer demands, and preferences were better understood and easier to meet by producers. "You can choose a color as long as it is black", says the celebrated quote by Ford that in a magistral manner summarizes the spirit of a manufacturing period that pushed products into customers. This strategy required large batches of the same or similar products. Profits appeared from economies of scale by fabricating large volumes with little or no variety and decreasing the average producing cost. A production with many of the same welds justified any investment in this quality control infrastructure as the extra costs became diluted in the average production costs per unit.

As demands for customization grew, computer dissemination facilitated meeting the new demands. Software packages like PLM for products, CAD/CAM systems for the link design/manufacture with CNC machines, or ERP at the enterprise level ensured the required flexibility and made this customization possible at mass production costs and improved quality. This is commonly known as mass customization. To maintain mass production profitability, product customization itself must occur at the very last stages of production, after the so-called decoupling point. Companies managed variability by offering customization options in catalogs, lists, and through the worldwide web. These options were added both as a combination of the opinion of the most relevant customers or trendsetters and the reasonable options to fabricate in the now so-called, and self-explanatory, mass customization processes. In terms of laser-welded products, different materials, equipment, personnel, standards, welding procedures were used. However, centralized planning was allowed since welds were known beforehand and the proper mechanisms to ensure quality could be established as well in a similar fashion that it was carried out at the mass production phase. Welding documentation could be designed to overlap all options offered and NDT could be used to inspect quality as in mass production.

And now, well into the 21st century, customers' demand highly customized and even personalized products, also in laser micro-welding applications like medical implants or hearing aids but also unique valves or flowmeters involving personalized features like different, exotic materials and weld thicknesses or additional features that may involve unique welds. Customers want to actively participate in the design of their products; they are co-designers *de facto* of products they buy but also that of the manufacturing processes to build these products, an approach that has been described as customer-oriented manufacturing [21]. Additional constraints for manufacturers are short lead times at mass production costs and with the highest quality levels alongside compliance with both standards and regulations. This imposes a very heavy toll on welding producers, which must juggle with standard compliance terms and with stringent and variable customer demands to reach previous profitability levels. Their challenge is to dilute large production costs due to managing this unpredictability that cannot be passed on to the customer. Companies that can meet these demands will gain a competitive advantage from more rigid organizations.

Industry 4.0 is an attempt to deal with these new constraints and with the uncertainty of an era dominated by the requirements of the demand side, the so-called pull economy. This novel manufacturing strategy, Industry 4.0, stems largely from the massive availability of data provided by the omnipresence of inexpensive sensors along the value chain. Digitization of both business and manufacturing processes, the consequence of it, exploits the use of machine intelligence in manufacturing operations to remove this volatility and embed in their processes the prescribed dynamism. These data can be used to get powerful insights in welding activities to determine better welding quality, welders and process performance, supplier performance, tooling and equipment calibration, preventive maintenance, etc., and enhance the value provided by ISO 3834. Smart Manufacturing shifts the attention from the manufacturing process to the product itself [22].

Cyber Physical Production Systems, CPPS, are the supporting technology that makes possible highly customized or personalized, high-quality goods at mass production costs [23]. CPPS are a collection of embedded systems, supported by Internet of Things applications, and networked together to sense, monitor, and actuate physical elements of the real world. It is not the combination but the intersection as they integrate computing and physical processes [24]. Similar to Reconfigurable Manufacturing Systems, RMS, used in the customization phase, these systems' main characteristic is responsiveness. Every resource on the floor like machines, robots, transporters are autonomous identities, namely a CPPS, which are equipped with cognitive capabilities such as perception, reasoning, learning, and cooperation [25]. Next to responsiveness, another required feature for CPPS technology is adaptability [26] not only to customer dynamic shifting preferences or personalization choices but also to changes in demand. This is where the importance resides, as a CPPS optimizes available resources while adapting to new situations and maintaining the system's goals. Therefore, Cyber-Physical Production Systems allow higher productivity, high quality, and at lower costs by taking advantage of the automation of several levels within a factory and the enterprise [27]. CPPS autonomously organize the reconfiguration.

This transformation, however, goes beyond the shop floor production level. A key aspect is the integration of the value chain both between companies, suppliers, even competitors and customers and within companies, all through digitation. This value chain design determines the relationship between the nodes of this value network. This network evolves from a linear transference of value between departments within an organization, and eventually between companies, as described by Michael Porter [28], into a nonlinear in which customers, suppliers, departments, equipment interact with each other and act as nodes of a network to produce value in a decentralized manner. Companies must seek collaboration both vertically and horizontally and this must happen along the lifecycle of the product that becomes integrated as well by offering services and including customers in the product design. All horizontal and vertical nodes of this business ecosystem are linked in the cloud where a platform integrates all these dimensions. This has been suitably named On-Demand Manufacturing by Hu [29], a term that perfectly illustrates the essence of the new manufacturing period. A self-organized, dynamic and real-time infrastructure, smart manufacturing, results from these considerations to reconcile both organizational objectives, and the requirements of the customers [30].

Welding business ecosystems have been described in the literature by Toivanen et al. At the center of the nodes there is a leading welding company that has the last contact with customers [31]. All subcontracted welding organizations are the nodes of this network and provide value to it. Through a manufacturing cloud, ubiquitous access to smart machines, production systems, as well as huge amount of data generated by different sources [32]. Organizational competitiveness is achieved by connecting and coordinating the activities of the nodes of the network and by the flowing of information in an auto, typically carried out by a cloud manufacturing platform. Some companies specialize in providing this optimization algorithm and like, Airbnb or Amazon, they profit by providing a mechanism to assure and enhance the value of the transactions between sellers and buyers or providers

and users. The perspective of the main node of the ecosystem, the closest to final the user, is maintained throughout this paper.

Companies then receive assignments and send them along the network to add successive layers of value. Thus, in one of such networks, a company provides materials, several of them provide the various welds, another partially assembles the final products. Another network with a different geometry, one node laser welds plates with thicknesses below a certain value, another these specific materials. Their goal is value adding to the network, and all of this is organized in a decentralized manner, in an intelligent manufacturing cloud platform. Having an architecture that depends on how the value chain is structured, welding networks are the pivotal, game-changing novelty for the welding industry [33]. Nodes strive to be part of an ecosystem so that they capture value by improving their resource efficiency, higher productivity and utilization rates [32], and by having access to other markets, though another node, that otherwise would have never had. The collaborative manufacturing system includes customers, experts, and enterprises and provides them with personalized services [34]. A Cyber-Physical Production System supports this vision the horizontal integration through value networks and the vertical integration through networked manufacturing systems can be built to realize smart factory and smart production [35].

The quality function is consequently altered in fundamental ways and therefore it is a more elusive concept that is has been to date. It needs to be multidimensional in that it must cover all integrated facets. A data-based quality management system will not be any longer about separating good from bad products in a line or identifying root causes of defects, but about adding value [36] to the conglomerate of companies where they operate and this occurs by integrating and decentralizing all the activities that take place within a company and its departments and within its customers and suppliers, a vertical and horizontal integration that deal with the internal challenges and external. Quality is now an artifact that can be only understood as part of a networked structure in which the ecosystem nodes deliver conjunctly quality, whilst value-added and data form together with the glue that ensures quality consistency at the various levels.

4. Analysis of Laser Welding Quality On-line Monitoring

If the manufacturing outlook context has changed at the macro level, it is at the production level where the revolution can trace its origins. The availability of both inexpensive sensors and renewed computer power triggers the digitization of production shop floor processes. For laser micro-welding, in-process signals in various energy emission forms, namely optical, acoustic, thermal, or imaging can be recorded, processed, and used for assessing welding quality. A welding defect and its location and its nature may then be uncovered by noticing a variation in the recorded signals. Real-time welding monitoring helps remove the open-loop, off-line nature of the quality control process, and provides accurate insights on aspects of a process such as tooling or equipment condition monitoring, welder, or procedure performance. Ultimately, Big Data analysis techniques can enhance and extract all additional information ingrained into it. By using machine learning or artificial intelligence techniques, and as well as the historical data collection grown through the years, on-line process monitoring would soon result in the identification of specific welding defect signatures. These data can be enriched by additional data captured horizontally and vertically across the value chain and network to provide an excellent tool to manage the quality holistically across the ecosystem.

4.1. Defects in Laser Micro-Welding

ISO 6520-1:2007 [37] provides a comprehensive list of all possible defects and nomenclature for its identification which is summarized in Figure 1. Although thickness below 0.5 mm is out of its scope, ISO 13919-1:2019 [38] contains a comprehensive list of laser welding defects for steel and nickel-based alloys. Figure 1 contains a summary of the most important defects. A separate one, ISO 13919-2:2021 [39] deals with aluminum, magne-

sium, and copper laser welding defects. The most predominant welding indications in laser micro-welding in the austenitic stainless steel-dominated high-pressure industry are crater and solidification cracks, underfill porosity, misalignment, excessive and lack of penetration, excessive reinforcement, spatters, and discoloration.

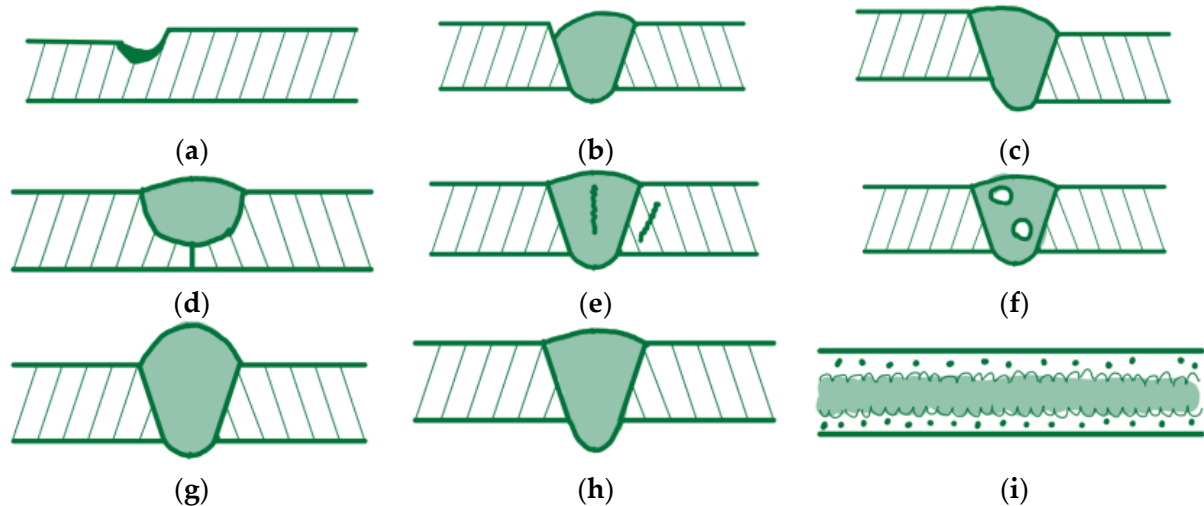

Figure 1. Laser micro-welding most common defects adapted from [38]: (a) End crater; (b) Underfill; (c) Misalignment; (d) Lack of penetration; (e) Cracks; (f) Porosity; (g) Excessive reinforcement; (h) Excessive penetration; (i) Spatters.

Solidification cracks occur in laser micro-welding because of the large cooling rates involved and the impurities present in materials [40]. These cooling rates may result in constitutional undercooling affecting its microstructure in a way that deteriorates its cracking resistance. Further, poorly designed laser micro-welding parameters can also create problems like craters at the end of welds by not sloping down the power correctly. Other manufacturing defects are deformation or shrinkage which are proportionally greater for smaller thicknesses than they are in lower density energy processes [41]. Poor part fitting or welding preparation can be as well very detrimental and result in misalignment. The small size of the laser beam and the joint preparation often cannot self-correct the problem as it occurs with lower energy density (or energy concentration per area unit) like TIG or MIG welding processes.

Incomplete penetration occurs when the weld depth is smaller than the part depth. In cyclical loading conditions, this defect may behave like a crack that may eventually induce a fracture. It can affect as well to the corrosion resistance of the material in the unpenetrated crevice. Excessive penetration may foster a notch effect that may result in fatigue in cyclical loading conditions. A similar defect is known as excessive reinforcement, and the notch effect occurs at the top of the welds. Porosities occur due to the dynamics of the keyhole. Both larger power and lower welding speed contribute to pore development [42] which may cause a diminished strength of the weld. High cooling rates may also lead to pore formation in very deep welds with insufficient degassing [43]. These high cooling rates contend with bubble buoyancy to keep oxides below the surface.

4.2. Defects Capturing

There is ample research that suggests a strong correlation between laser processing data like optical, visual, thermal, and acoustic emissions and laser welding defects.

4.2.1. Light Emissions

During welding, the laser reflects light in the visible, infrared, and ultraviolet wavelengths. Spectrometers and photodiodes are used to capture these emissions for further processing [44]. De Bono et al. have provided evidence of the existing correlation between welding preparation and energy emissions from the laser welding process. Monitoring

wavelengths between 600–850 nm showed defects indicating that samples were not well aligned, clamped, etc. Similarly, attempts to predict penetration in butt welds for 718 nickel-based alloys were successful [45]. Sibillano et al. used a spectroscope to analyze laser welding optical emissions that provided several advantages for real-time welding defects identification. Data captured from the optical spectra from the plasma emitted by the keyhole of the laser process are used to detect defects [46]. Mrňa et al. analyzed the correlation between penetration depth and the frequency characteristic of the light intensity oscillations. The method may be extended as well to the various changes in the dynamics of the weld pool [47]. In a different study, Mrňa et al. designed a feedback control for laser welding applications based as well on the frequency analysis of the light reflected. Furthermore, Hollatz et al. concluded that an Optical Coherence Tomography system, OCT, can be used to measure the keyhole depth of laser micro-welding processing [48]. Optical emissions and welding defect formation exhibit statistical correlation that results in defect identification. Their analysis can provide as well important information on the root cause analysis of the welding defect.

4.2.2. Acoustic Emissions

Microphones or resonant sensors can be used to measure pressure fluctuations as plasma ejects from the keyhole during laser welding [49]. Falling back on this physical phenomenon, Schmidt et al. focused on spatter formation using initially conventional analysis of these acoustic signals. More successfully, were attempts to use machine learning techniques for the same purpose [50]. Kuo et al. determined a correlation between sound signals and joint strength for micro lap welding [51]. Real-time monitoring of laser combined X-ray imaging with acoustic sensors and state-of-the-art machine learning by Wasmer et al. found a defect correlation between 74–95%. Remarkably, this system was able to distinguish among the various laser welding regimes: conduction welding, stable keyhole, unstable keyhole but also spattering [52]. Transition mode between keyhole and conduction may be erratic and result in multiple welding defects. Shevchik et al. devised a method to determine welding quality by capturing acoustic measurements that are the derivatives of the shockwaves, generated inside the workpiece directly during processing [53]. They attained a confidence level ranging between 82–95%. This research indicates as well that there exists the prospect to distinguish between laser welding regimes.

4.2.3. Image Processing

Conventional devices used to detect heat transfer patterns are CCD cameras, CMOS cameras, and high-speed cameras. Special filters are applied to capture the images of the keyhole, molten pool, and plasma [54]. Research shows a correlation between the morphology of the weld and welding quality. In one of such studies, welding data were received by a coaxial high-speed camera and labeled with the porosity attributes measured from welded specimens. Aided by a convolutional neural network (CNN) model with compact architecture, weld-pool patterns were deciphered to predict porosity. A stunning 96.3% success rate was achieved [55]. This method lends itself very well to mass production as machine vision can enhance efficiency and decrease inspection costs [56]. Used in combination with data analytics, it can be effective as well for personalized production in which inferences can be made from previous experiences.

4.2.4. Thermal Signals

The most widely used sensors to gather molten metal emitted light are infrared cameras and pyrometers. The optical signal is proportional to the temperature of the weldment. Early research by Chandrasekhar et al. employed IR images to successfully infer the depth of welds [57]. Similarly, Weberpals predicted geometric features by analyzing thermal radiation [58]. Finally, a high-speed infrared camera was used by Chen et al. to correlate the molten pool morphology and welding defects [59].

4.2.5. A Hybrid Data Collection

A particularly interesting feature is the combination of multiple sensor coaxial or paraxially to collect multiple welding signals to enhance the interpretation of welding quality. Fusing several source data has been challenging to date but research has shown that data can be simultaneously used to complement each other and to clarify specific welding situations [60]. By merging the high-speed photography and image processing technology, for instance, laser-induced metallic plasma and keyhole size were quantified which in turn indicates information about the weld depth. Two photodiode sensors and two visual sensors were utilized [61]. Optical and infrared sensors are sensitive to capture plasma radiation signals and can reveal welding features like cooling rate temperature gradient and melt pool 3D geometry that other methods are unable to provide [62]. Artinov et al. observe the weld pool geometry by means of a high-speed camera and an infrared camera recording. The observations show that the dimensions of the weld pool vary depending on the depth [63]. Further sensor combinations like that of blending electrical signals and high-speed photography have been shown to lead to defect detection during laser welding [64]. Although measuring only propensity to welding defects like lack of full penetration by indicating which mode is present along the welding process, the electrical detection of laser welding plasma is effective for evaluating plasma temperature and dynamic behavior in laser welding. This effect can be used for the monitoring of mode transition, conduction indicating lack of penetration [65]. Table 1 depicts a summary of monitoring objectives at the various welding stages and their associated technology.

Table 1. Sensor technology for welding defect detection at the various stages. Adapted from [60].

Stages	Monitoring Signals	Objectives
Monitoring before welding	Optical signals	Seam tracking and gap measuring
Monitoring during welding	Acoustic signals Optical signals Electrical signals Thermal signals	Defects monitoring, feedback control and feature prediction
Monitoring after welding	Optical signal Acoustic signal	Defects classification and weld geometry

4.3. Defects Diagnosing

Artificial Intelligence and, in concrete, Machine Learning, supported by the availability of sensors and IoT in an industrial setting, can be used to infer weldment morphology and welding defects classification [66]. The Artificial Intelligence methods used to model high nonlinear relationships, such as those occurring in laser welding, are superior to the conventional linear method [67] considering that welding processes can be idealized as a stochastic system with several inputs and outputs [68]. Moreover, data mining processes, machine learning, deep learning, and reinforcement learning techniques have displayed positive results in the analysis and control of systems as complex as the welding process [68]. Data mining techniques to extract knowledge by identifying previously unknown cause-effect relationships [69]. The introduction of IoT technologies in factory automation enables the adoption of Machine Learning (ML) approaches for quality monitoring [70]. In addition, neural networks comprising radial basis function neural network, back-propagation neural network, and generalized regression neural network can be used, for instance, to determine the correlations of the laser melting pool and keyhole and the welding seam [71].

5. Framework of an Intelligent Laser Micro-Welding Quality Management System and Its Implementations

The previous sections discussed the legal and business environments in which high-pressure equipment manufacturers with welding responsibilities must operate. The discussion zoomed into an understanding of. It has been shown that a laser welding process accepts digitization and the challenges around the welding ecosystems and industry 4.0.

Digitization redefines the terms in which a company relates to itself and to the rest of the world. All business processes that can be digitized add intelligence to the business which results in a higher degree of autonomy, dynamism, and a better understanding of the operational environment, which is represented by both vertical and horizontal integration, a manufacturing strategy specifically designed to successfully deal with all market variability. In fact, these increasingly complex organizational demands rely on intelligent networking which makes obsolete any centrally controlled system in production [35]. If criticisms of current welding quality assurance by ISO 3834:2021 include the somewhat open-loop character and its static, snapshot nature, integration at all levels of a welding organization provides the dynamism and real-time character that it was missing. Then, intelligent, data-based welding quality management systems can constitute the basis for a new framework for quality control and assurance in laser micro-welding companies and specifically in the high-pressure equipment industry. Integrating all activities within ISO 3834:2021 and providing it the required intelligence results in a new framework for laser micro-welding quality assurance with obvious applications to other welding processes.

Figure 2 illustrates a framework architecture and its implementation perspectives. An industrially feasible hardware architecture can solve this problem. A preprogrammed and predesigned FPGA receives real-time laser welding processing data, which is plotted in a previously designed multiphysics simulation model embedded in this FPGA. These results of the interpretation are sent back to the gateway that initiates the required actions to modify the welding pool and hopefully avoid or mitigate the welding defect. These data are sent to an artificial intelligence application that processes it further and sends it back to the FPGA, or GPU, which in turn utilizes a Shiny App to report remotely to all stakeholders like customers, suppliers, network nodes, Notified Bodies, and departments across the organization. This tool facilitates the vertical and horizontal integration of all processes involved in managing the welding quality consistent with Smart Manufacturing principles and with ISO 3834:2021 principles in terms of procedure and welder qualification, testing and inspection, calibration, tooling, etc.

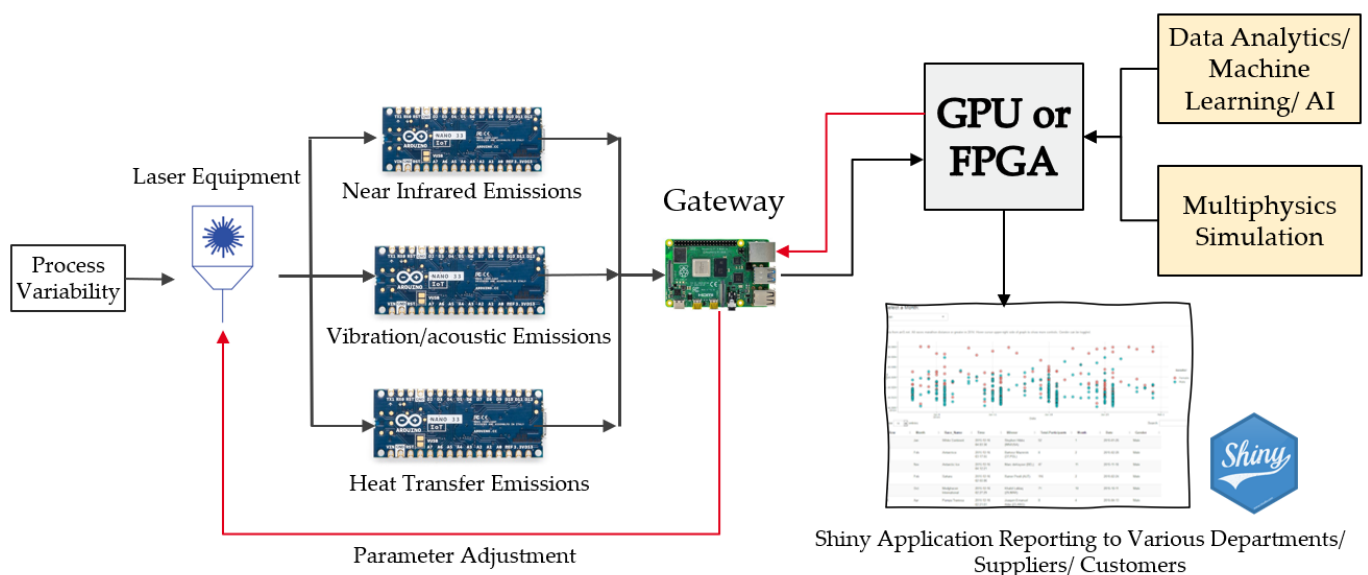

Figure 2. Illustration of the framework for a smart laser micro-welding quality management system further in line with ISO 3834:2021 standards [44,72].

5.1. Vertical Integration

Vertical integration entails the digitization and alignment of all activities within a company. In this new structure, the digital and real-world in terms of data, events, and information interact with each other [73] which boosts operational efficiency and removes

to a large extent the manufacturing consequences of variability. Vertical integration leads, in fact, to a competitive advantage when developed because it enhances a manufacturer's responsiveness to changing conditions [74]. To be successful in this regard, since operational planning, scheduling, and welding production tasks are interdependent, planning these activities should be solved in parallel and integrated. This is achieved by data flow to provide informative feedback to support real-time optimization [75].

5.1.1. Welding Procedures and Welder Qualifications

At the most basic level on the production shop floor are the welding processes. Thus, a Welding Procedure Specification, WPS, is a document containing the essential and non-essential welding variables that will consistently result in a sound welding procedure and described in ISO 15607 [76]. The essential variables in a WPS are those that have an impact on the mechanical and metallurgical properties of a weldment. A WPS follows an externally endorsed process validation structure. For Risk Categories I and higher, a Notified Body Third-Party Authority must witness both the execution of the welding process and posterior destructive and non-destructive tests, endorsing all the results. The Notified Body writes up the Welding Procedure Qualification Record, WPQR, for the process qualification, and a Welder Performance Qualification, WPQ for the welding operator qualification. See [77] for a complete description.

Öberg et al. studied the repeatability of the same WPS development in different manufacturing sites discovering major variations in results due to tolerances. The same initial conditions and materials resulted in different WPS and different quality [78]. This outcome questions the universality of a WPS, one that can be developed and implemented among different manufacturing locations or companies and result in identical quality levels and costs. The WPS system offers a static view of a welding process, a snapshot. Laser welding is a complex, nonlinear process influenced by variables like power, welding speed, spot diameter, material, etc., all of which are registered in a WPS. It fails to reflect the combined effect of little deviations in process variables when they interact and influence each other. Isolating and analyzing the individual effect of each one in a WPS seems not enough.

There are additional, well-documented criticisms of the WPS systems. Some companies consider them a nuisance and try to comply without embracing the system. They get the required qualifications and certificates to satisfy customers' requirements and to gain access to contracts but miss to train welding operators and welders on how to use them. The qualification process is considered expensive and in consequence, some companies try to cut down the number of qualifications by enlarging the approved ranges. One WPS fits all procedures, a practice that debunks the intention of the system. Welding engineers frequently see errors and typos in WPS. A WPS should be a live document and be constantly challenged by real-life results.

Digitization of laser welding processes brings along alternatives that will mitigate and even eliminate these constraints. For once, capturing real-time data may remove the static nature of the current practices. It does away with value and parameter averaging now embedded in many WPS. On-line data bestow the required granularity for understanding and for managing larger complexity applications such as those pertaining to light-matter interaction of laser welding. When these various forms of energy emissions are captured in combination with real-time values of the essential variables, the process insights are even greater [62]. Furthermore, when these two sets are analyzed alongside historical laser welding data, then quality can be assured. Moreover, these data can be enriched by data collected by the power sources to result in detailed performance documentation for each weld. This, in fact, provides more insights than simply by witnessing the process itself as some customers actually request. In addition, digitizing data can facilitate optimal parameter design that will do away with the WPS universality problems described by [78]. Data can be stored in the cloud and be made available to customers and other members of the value network.

Similarly, qualifying welding operators can be performed as well by adding the data digitally to all welding documentation. Having a welding operator weld some predetermined length, witnessed by a Notified Body, as the standards currently state [79], seems to be insufficient proof of welding competence. Integrating this process involves that next to the welder's qualifying process data, historical data can be used, as time progresses, to verify the adhesion of the welder and welding company to the approved procedure and certified welding operator. This may result in an additional task for these Third-Party Authorities, capturing and assuring veracity and integrity of data as digitization transforms the role of Notified Bodies as well. Besides endorsing welding process variables and their corresponding test results, now they may add supplementary value by endorsing the data collected during welding qualifications and by safeguarding the data produced in the qualifying welding process and attaching it to a WPS to assure standard compliance.

5.1.2. Inspection and Testing of Laser Micro Welds

Once in the production setting, welds are carried out from an approved welding procedure and by a certified welding operator, and a testing procedure to examine the welding integrity is required. At present, welding manufacturers perform quality control in a production setting by deploying well-known Non-Destructive Technology, NDT, to verify the absence of both surface and volumetric defects and, therefore, the weld's strength to meet the required load. These surface detection techniques are Visual Inspection, VT, Penetrant Test, PT, Magnetic Testing, MT. Among volumetric techniques, those verifying inside the welds, are Radiographic Testing, RT, Ultrasonic Testing, UT. Depending on the Risk Category, personnel executing the tests may be qualified and certified according to standards as well. A leak or hydrostatic pressure test can supplement NDT techniques to identify compromised welds.

These techniques' effectiveness, however, is severely compromised by the small size of the welds and by the compactness driven by the micro-manufacturing industry. Traditional off-line inspection of welded joints is expensive and reduces productivity. Both surface and volumetric inspection techniques are hard to be performed on small welds with thicknesses around 50–100 μm . They may be in some cases detected in a laboratory environment, but their effectiveness is questionable for production settings with large batches of possibly very different products and therefore unique welds, such as those of On-Demand Manufacturing. For laser micro-welding, this is a time-consuming, expensive practice that could be easily supplemented, if not substituted altogether, by monitoring online data that have demonstrated correlation with defects (see Section 4). These data could pinpoint welding inspectors which products offer doubts and even in which position of the weld the indication may exist. This simplifies the inspector's work and the selection of the NDT technique. This combination may remove the random component of the current tests.

NDT will not decrease in importance. Process captured data can be used in conjunction with data captured at NDT checkpoints to add more intelligence to the welding process activities. A combination of NDT and data in-process monitoring can help enhance the quality. It can also provide insights on welders and welding process performance. NDT equipment could be added to the Cyber-Physical Production System, CPPS, that On-Demand it will inspect quality either on surfaces or internally as data pinpoints. This is how the testing will be carried out with random and oriented leak tests.

5.1.3. Equipment Maintenance, Calibration and Tooling for Laser Micro-Welding

In Section 9 of ISO 3438-2:2021, it is stated that the manufacturer shall have documented plans for the maintenance of equipment. It deals with the equipment; the description and provisions must have been made clear. It also explains the need to validate new equipment. Next to all fundamental maintenance tasks like lubrication of moving parts, cleanliness assurance, or filter replacements, laser welding equipment needs some work like optical cleansing, beam quality testing, chiller review, shielding gas conduction, and flow

management. Data collected during the micro laser processing of materials can indicate a deterioration of these elements and help schedule maintenance stops.

The nature and origin of the data used in predictive maintenance are heterogeneous in that it has a different origin, and it is used to uncover abnormal behaviors of equipment and predict future malfunctions [80]. This allows a proactive behavior that allows preventive maintenance schedules to be ingrained in horizontal and vertical planning of operations. This feature is very valuable for a value network to understand the state of the equipment and where there will be stops way ahead of time which will turn into better utilization rates, efficiencies and lead times and quality for the entire network. Not surprisingly there is a strong research focus on creating algorithms that optimize the asset management processes based on data analysis capabilities. Predictions based on welding data will be extremely useful in the planning phase of a value network. This by itself adds value to the better utilization rates of the value network itself.

In-process data can lead to a greater understanding of the performance of ancillary equipment used for laser micro-welding like fixtures and jigs. Next to laser micro-welding defects, and equally important for quality assurance of micro laser welds, are collecting data that can help infer a decline in tooling performance. As suggested on Section 4, data captured in-process can provide insights on the misposition of the welds. This is caused directly by welding operators' error, but also, more importantly, by poor tooling that failed to be *poka-yoke*. Furthermore, smart analysis of the data can result in insights as to here and how tooling fails to secure products in the correct position. In combination with design databases, it can improve the design smartly as well.

Furthermore, it can help understand when calibration is required and what exactly needs to be calibrated (data and when new tooling is due). Per ISO 3834:2021, calibration is carried out once a year and a certificate is required from the calibration company. This is an arbitrary period that may or may not be reasonable at all in all instances to comply with. Having data available to demonstrate calibration can be a more effective method. Again, these data, or their interpretation by algorithms can be used by a company and by its ecosystem to demonstrate compliance. The manufacturer shall be responsible for the appropriate calibration or validation of measuring, inspection, and testing equipment. All equipment used to assess the quality of the construction shall be suitably controlled and shall be calibrated or validated at specified intervals. A trend is the availability of electronic work instructions. Doing so ensures the latest version is always available.

Currently, and following the spirit of ISO standards and quality management systems, documentation is required to demonstrate timely maintenance and calibration of welding equipment. Industry 4.0 enhances this transparency as historical data can show the status of the equipment a well. Rather than a static document, historical data can be served to prove maintenance. The activities can be modified to include data-advised activities. These data can be in the clouds for ecosystem verification and utilization.

5.2. Horizontal Integration

Digitization goes further than integrating the shop floor production level with other departments of an organization. It also alters the logic in the way companies relate to each other by merging the complete value chain. Arguably, horizontal integration, as it is known, has substantial consequences for how companies add value and conduct their business. From a welding quality perspective, the resulting entity from this integration, the collaborative network offers the means for seamless incorporation of in-process production data and information internally, providing tools for managing suppliers more effectively and efficiently [81] and to satisfy customers better.

5.2.1. Requirements, Technical Challenges and Subcontracting

Horizontal integration allows nodes of these collaborative networks that result from the horizontal integration of suppliers and customers, to specialize in specific welding processes, or specific material types, or material dimensions like diameters and thicknesses.

This horizontal versatility ensures compliance with standards while optimizing both the speed and low costs customers require while safeguarding quality. Adopting such a strategy should expedite personalization opportunities for the network as more options are feasible. Full utilization of each node's capacity and meeting challenging personalization requirements is possible by adding new nodes. These activities are known as On-Demand manufacturing systems, a part of a service-oriented paradigm [32]. A smart welding quality management system should provide for and encourage this new way to conduct business.

Quality management systems have been known to delay companies [82]. Clearly, speed is lost when lengthy current qualifications of welders and welding processes for unique co-designed and personalized products are to be made for small series or batches of one. The competitiveness of the company may deteriorate as a result. Cloud manufacturing, another Smart Manufacturing tool, can provide an immediate overview to assignment givers of the available welding documentation for given processes, the NDT possibilities, the in-process monitoring, and NDT facilities. Cloud manufacturing improves resource efficiency, higher productivity, and utilization rates of its participants. Nodes of the welding network offer combined and through a cloud platform ubiquitous access to smart machines, production systems, and as well as a large amount of data [32]. Companies that can quickly adapt to the fast-moving pace of digital industrial ecosystems will stay competitive, whereas companies lose their customers when they cannot anticipate demands for connected products and services [62]. This construction should be included in a smart welding quality management system to facilitate new operating ways.

Companies in the value chain can share and combine manufacturing services and approved WPS, PQR and WPQ together with smart welding equipment within manufacturing systems. Personnel executing the welds and the NDT inspectors, if required, together with their qualifications and data records can be shared in the cloud. They further share all available data on equipment maintenance, calibration to the ecosystem. This provides a historical review as well also in terms of supplier selection per job and serves to relieve all contractors' work. Data on welding processes reliance, like defect numbers, corrective measures improving quality data, the correlation between material numbers and—in different words—data analytics can be shared in the value network for it to collect a collectively larger amount of value than the sum of the individual value added by each individual node.

Traceability is therefore ensured as well by associating a serial number to data associated with a specific weld and by adding to the package either historical data or a report from the historical analysis. Material certificates can be entered. These data can be captured from suppliers and compared with that captured in operations. The conclusions can be used to either assess the supplier's performance or find together solutions to improve it. All quality data required by the standard are placed in the cloud and made available vertically and horizontally.

5.2.2. Production Control

Quality Plans and Manufacturing Plans are written to detail all steps in the manufacturing processes, focusing often on welding and its quality assessment manner. This documentation is often accompanied by the needed WPS, WPQR, and WPQ. On occasions, independent inspectors are sent to verify and witness the welding and NDT processes. This document-oriented process is a legalistic activity. Industry 4.0 can change the relationship into one of responsibility and collaboration [83].

Instead of these documentation requirements that foster inefficiencies, data can be supplied for production control. The original welding procedure qualifying data, collected and endorsed by the NoBo, can be placed in the cloud attached to data captured during the actual welding process. The comparison of these two sets would ensure strict adherence to the qualified WPS and by the correct WPQ of the welding operator. Moreover, the final or intermediate customer can remotely witness the process using cameras in combination with world-wide-web applications like Shiny App that display processing data for all

stakeholders at all vertical and horizontal dimensions. Customers can incorporate the data into their analytic tools to assess the quality and accept products. Alternatively, data analysis of the specific node may be deemed acceptable by the customer.

These data can be delivered vertically as well to evaluate performance. The type of defects found in the data can prompt action in the various departments. Process data that indicate mispositioning of the parts before welding may indicate to a manufacturing engineer, that tooling is worn out, or broken or that the materials supplied by a supplier contain an inordinate percentage of impurities or an inadequate amount of a determining element in an alloy. Data that only occur when a specific welding operator is operating the equipment may trigger the HR department or operations management to observe that this employee either needs more training or better management. This autonomous, decentralized nature at both vertical and horizontal levels exemplifies the spirit of Smart Manufacturing and should be represented in the smart quality system.

5.2.3. Welding Coordination

A welding coordinator whose tasks, and responsibilities as well as their level of required competence are described in standards [84], ensures that all prescribed guidelines in ISO 3834 are observed, by securing correct implementation of standards and control and supervision of all welding activities to meet quality requirements. Adding intelligence to the coordination and execution of these activities reinvigorates a welding organization. The welding coordinating of the final network node, the closest to the final customer or user, must be aware of all data produced by the network and by the organization itself. A welding coordinator must now maintain and own a package that uses large amounts of data as evidence that all procedures and activities have been completed in a satisfactory manner. Given the new decentralized and autonomous manufacturing operations, additional responsibilities to this role will be now algorithm creation and data management. Further responsibilities will be data integrity verification and data analysis for process improvements like the design of better tooling or more sophisticated process controls, to name a few.

5.3. End to End Integration: Co-Design, Servitization and Business Models Support

All network nodes' activities are further integrated into one direction along the product life cycle. This additional consolidation complements both vertical and horizontal integrations. Smart Welding Quality Management systems must incorporate and make provisions for welding quality in environments in which co-designed, unique products are to be manufactured. Design is not part of a welding quality standard per se, but its activities can now be digitized [85] and, therefore, measured and made part of the welding quality system. Codesign involves the direct participation and involvement of customers and final users in the design, manufacturing, inspecting, and testing of their equipment. This process will likely entail many interactions, tests, data collection, and interpretation that, after its anonymizing, can be sold to prospective customers. For companies that foster the co-design of products and their manufacturing processes, it means that they need to introduce customers, users, and people in the early stages of product innovation [81] and also along the product and service lifecycle.

Starting then with product co-design, historical welding data can be analyzed to predict the performance of new welds that involve new materials, new thicknesses, and new configurations designed solely to serve these unique product personalization strategies. Implementing these one-of-a-kind innovations may render already qualified welding procedures and welding operators of the value network futile. Newly co-designed welds may need to be streamlined into the existing manufacturing systems, and data should support the manufacturability. Digitization of the welding process produces historical data that can be used to enhance and illustrate the options at the design phase even for completely new welding configurations.

But customers do not design only products. They design manufacturing processes as well, which include welding. Customers can make more educated decisions using data analytics of previous experience with anonymized data from previous welding history. Inferences can be made from similar albeit not equal past situations. In this context of multidimensional integration, data captured during welding can add value to the product delivered to customers. Rapid prototyping for tooling can be supported as well by data from welding based on previous experiences and data collection. Since there is a well-established correlation between welding defects produced by mispositioning of the parts, poor fit-up [45], then the new parameters can be designed using anonymized historical data through linear or non-linear relationships. Testing and inspecting high-pressure instruments follow the same path. The design and manufacturing interaction are data that can be used. Further, these data can be sold to prospective customers. Smart welding quality standards need to include this tendency.

In effect, this data creation process fosters servitization, a source of additional profits by adding services to the products. This has a large impact on business model design, as strategists must decide what percentage of product and what percentage of service it offers to customers [86]. For example, data can be part of a package combined with the product that can help the customer in their future co-creation projects or learn about the performance in the field of a specific weld design. Data captured may serve along the process by providing insights, for instance, on the product performance as a function of a selected welding configuration or material combined with other product data. Products are intelligent and capture the data that are stored in a CRM and used for the next products for a specific customer. Manufacturers can offer services with Big Data [87] but additional services can consist of offering manufacturing facilities and equipment for On-Demand availability. All these attempts to increase profitability must be aligned in a business model.

The creativity and business insights within the network should help determine how to sell these data as part of a service through a suitable dynamic business model. Business model innovation constitutes a new competitive advantage [88] that can help explain how a company does better than its rivals [89]. Some studies suggest that business models innovation may yield higher returns than product or process innovations [86]. Companies in the network must then strive for the optimization of their business model that contains a strategic alignment of available capabilities and competencies seeking combinations of services and product features that maximize customer satisfaction and, consequently, profits. An intelligent quality management system that serves in this manufacturing era should adapt to this new business environment very different from that of mass production in which it was conceived.

6. Future Research and Development

The future research and development for laser micro-welding in the context of Industry 4.0 and high-value engineering application, likely fall in the following themed areas:

- **Welding data and analytics:** Quality of the information and data captured may constitute a concern and be perceived by some as a limitation to digitization. Further research should be directed to determine when and how welding data quality and the associated analytics are acceptable. The research should pinpoint if an aspect of welding quality should be dependent on data quality and the underlying analytical algorithms and analytics. The integration of Industry 4.0 is assembled on the reliability premise of welding quality. A methodology to measure welding data and ensure their quality should be researched likely through in-process measurement. Standardization of data is also an interesting research area. Incorporating these ideas above into the regular business activities may be the forfeiting of quality data. Traditional NDT reports and data, however, can be falsified, of which most welding professionals are often aware. Blockchain technology, so appropriate for this context, may increase the technology to do so, while limiting the incentive for fraud. NDT data integrity and veracity are areas that should be further researched. Research and development

addressing digitization in quality management are further expected to identify all defects and their intricate correlations.

- Welding quality certification and documentation: Product personalization and/or customized product co-design multiply the need to qualify many additional WPS at every exchange with customers, as the design may be unique and involve no previous experience in those specific welds. A fascinating research theme could be the extrapolation of historical data to determine the process parameters for a new weld. Researching the results of allowing this practice in ISO 15611-4, qualification based on previous welding experience, should add substantial value. Updating the ISO 3834 family to reflect these new realities should be considered in research as well, particularly through integration with industry 4.0 principles and data automation.
- There is abundant literature on signal processing of laser welding thicker plates and butt welds on the most common materials used in industry, like steels and aluminum. The research appears to focus often on a generalized “one for all” solution. Further research is needed to find signal correlations to other materials and combinations, including dissimilar materials, weld preparations and joints and smaller thicknesses to establish causality between welding signal and specific defects.
- Business ecosystems for welding: Further research is required for a better understanding of welding process/value chains, their morphology, and strategies for capturing and providing added engineering value. Nowadays there is only incipient research available.
- A final interesting topic is to study the optimal ratio between vertical to horizontal integration for high-value welding companies.

7. Conclusions

This paper attempts to provide a comprehensive and critical analysis of laser micro-welding quality management systems applications for high-pressure instruments manufacturing. The research work is particularly focused on developing the framework for an intelligent quality management system integrated with industry 4.0 principles and its implementation perspectives. The following key conclusions can be drawn up as the work progresses:

1. Industrial companies applying laser micro-welding often encounter difficulties assessing the quality of their small welds, particularly in a high-value manufacturing environment, in which defects are not allowed and can be detrimental to business. While appropriate for a lab setting, a mass production-oriented NDT protocol is costly and thus hard to apply on a production shop floor.
2. Digitization of the welding processes brings along important consequences for both the production shop floor level and business level. For once, it facilitates the digitization of all activities involved in ISO-3834:2021, which inevitably results in an intelligent welding quality management system. An intelligent quality management system is dynamic and able to offer continuously a varying “snapshot” of the entire quality system, from suppliers or nodes of the network to the various vertical processes inside the company.
3. The complexity and nonlinearity of the quality system can foster the required coarseness that cannot be captured in the traditional welding quality management philosophy. The intelligent welding quality management system is data-based and works in the industry 4.0 context, which provides the new framework for quality control and assurance in the laser micro-welding industry for high-pressure products/applications in particular.

Increasingly, laser welding equipment suppliers are offering data acquisition and storing options in their equipment. Furthermore, existing equipment can be refurbished with similar functions as companies with heavy research emphasis offer now data capturing devices. A first step would be determining the type of defect that is expected for specific materials, weld joints, welding positions, or tooling. The nature of these defects, in turn,

establishes the most appropriate type of signals required to be identified online. Be they optical, acoustic, or thermal, the selection of the signal determines the equipment and the most suitable data analysis tools as well.

High-value manufacturers with a laser welding competence should take advantage and align their production processes and their business models to reflect the new reality. Servitizing the business by sharing data and horizontally and vertically can result in benefits for all ecosystem participants. Similarly, welding quality system management standards should be reviewed appropriately to reflect the new business paradigm and smart so that it fosters the embedment of intelligence. Laser welding could be the best place to start and move into other welding processes once lessons learned are available.

Author Contributions: Conceptualization J.L.V.d.l.H. and K.C.; methodology, J.L.V.d.l.H. and K.C.; analysis and synthesis J.L.V.d.l.H. and K.C.; supervision J.L.V.d.l.H. and K.C.; project administration J.L.V.d.l.H. and K.C. All authors have read and agreed to the published version of the manuscript.

Funding: This research received no external funding.

Institutional Review Board Statement: Not applicable.

Informed Consent Statement: Not applicable.

Data Availability Statement: No significant datasets were analyzed in this study or created to support it.

Conflicts of Interest: The authors declare no conflict of interest.

References

- Ivanov, A.; Cheng, K. Non-Traditional and Hybrid Processes for Micro and Nano Manufacturing. *Int. J. Adv. Manuf. Technol.* **2019**, *105*, 4481–4482.
- Naem, M. 7-Developments in Laser Microwelding Technology. In *Handbook of Laser Welding Technologies*; Katayama, S., Ed.; Woodhead Publishing: Sawston, UK, 2013; pp. 163–211.
- Patschger, A.; Bliedtner, J.; Bergmann, J. Process-limiting Factors and Characteristics of Laser-based Micro Welding. *Phys. Procedia* **2014**, *56*, 740–749. [[CrossRef](#)]
- ISO. 3834-1:2021 *Quality Requirements for Fusion Welding of Metallic Materials—Part 1: Criteria for the Selection of the Appropriate Level of Quality Requirements*; ISO—International Organization for Standardization: Geneva, Switzerland, 2021.
- Carvalho, A.V.; Enrique, D.V.; Chouchene, A.; Charrua-Santos, F. Quality 4.0: An Overview. *Procedia Comput. Sci.* **2021**, *181*, 341–346. [[CrossRef](#)]
- Chiarini, A. Industry 4.0, Quality Management and TQM World. A Systematic Literature Review and a Proposed Agenda for Further Research. *TQM J.* **2020**, *32*, 603–616. [[CrossRef](#)]
- Albert, W.; Goekhan, A.; Teresa, W. Quality Management—History and Trends. *TQM J.* **2015**, *27*, 281–293.
- Pressure Equipment Directive (PED), 2014. Available online: https://www.euronorm.net/content/ce-marking/directives/en_36.pdf (accessed on 17 April 2021).
- EN. 13445—*Unfired Pressure Vessels*; European Committee for Standardization: Brussels, Belgium, 2016.
- EN. 13480—*Metallic Industrial Piping*; European Committee for Standardization: Brussels, Belgium, 2017.
- Regulation (EC) No 1272/2008. 2008. Available online: <http://data.europa.eu/eli/reg/2008/1272/oj> (accessed on 22 May 2021).
- Council Directive 85/374/EEC, No L 210/29, 1985. Available online: <https://eur-lex.europa.eu/legal-content/EN/TXT/PDF/?uri=CELEX:31985L0374&from=EN> (accessed on 10 April 2021).
- ISO. 9001:2015 *Quality Management Systems—Requirements*; ISO—International Organization for Standardization: Geneva, Switzerland, 2015.
- Ulewicz, R.; Nový, F. Quality Management Systems in Special Processes. *Transp. Res. Procedia* **2019**, *40*, 113–118. [[CrossRef](#)]
- Shackleton, D.N. Reducing Failure Risk in Welded. *Weld. World* **2006**, *50*, 92–97. [[CrossRef](#)]
- Duffy, G.L. *The ASQ Quality Improvement Pocket Guide: Basic Components History, Concepts, Tools, and Relationships*; Quality Press: Lincoln, NE, USA, 2013.
- ISO. 3834-5:2021 *Quality Requirements for Fusion Welding of Metallic Materials—Part 5*; ISO—International Organization for Standardization: Geneva, Switzerland, 2021.
- ISO. 3834-2:2021 *Quality Requirements for Fusion Welding of Metallic Materials—Part 2: Comprehensive Quality Requirements*; ISO—International Organization for Standardization: Geneva, Switzerland, 2021.
- ISO. 3834-3:2021 *Quality Requirements for Fusion Welding of Metallic Materials—Part 3: Standard Quality Requirements*; ISO—International Organization for Standardization: Geneva, Switzerland, 2021.
- ISO. 3834-4:2021 *Quality Requirements for Fusion Welding of Metallic Materials—Part 4: Elementary Quality Requirements*; ISO—International Organization for Standardization: Geneva, Switzerland, 2021.

21. Fornasiero, R.; Carpanzano, E. Advances in Customer-Oriented Manufacturing and Value Chain Management. *Int. J. Comput. Integr. Manuf.* **2017**, *30*, 677–679. [[CrossRef](#)]
22. Foidl, H.; Felderer, M. Research Challenges of Industry 4.0 for Quality Management. In *Innovations in Enterprise Information Systems Management and Engineering, Proceedings of the 4th International Conference, ERP Future 2015—Research, Munich, Germany, 16–17 November 2015*; Revised Papers; Felderer, M., Piazzolo, F., Ortner, W., Brehm, L., Hof, H.-J., Eds.; Springer International Publishing: Cham, Switzerland, 2016; pp. 121–137.
23. Zheng, T.; Ardolino, M.; Bacchetti, A.; Perona, M. The Applications of Industry 4.0 Technologies in Manufacturing Context: A Systematic Literature Review. *Int. J. Prod. Res.* **2021**, *59*, 1922–1954. [[CrossRef](#)]
24. Oztemel, E.; Gursev, S. Literature Review of Industry 4.0 and Related Technologies. *J. Intell. Manuf.* **2020**, *31*, 127–182. [[CrossRef](#)]
25. Tran, N.-H.; Park, H.-S.; Nguyen, Q.-V.; Hoang, T.-D. Development of a Smart Cyber-Physical Manufacturing System in the Industry 4.0 Context. *Appl. Sci.* **2019**, *9*, 3325. [[CrossRef](#)]
26. Otto, J.; Henning, S.; Niggemann, O. Why Cyber-Physical Production Systems Need a Descriptive Engineering Approach—A Case Study in Plug & Produce. *Procedia Technol.* **2014**, *15*, 295–302.
27. Tilbury, D.M. Cyber-Physical Manufacturing Systems. *Annu. Rev. Control Robot. Auton. Syst.* **2019**, *2*, 427–443. [[CrossRef](#)]
28. Porter, M.E. *Competitive Advantage: Creating and Sustaining Superior Performance*. Free Press: London, NY, USA, 1985.
29. Hu, S.J. Evolving Paradigms of Manufacturing: From Mass Production to Mass Customization and Personalization. *Procedia Cirp* **2013**, *7*, 3–8. [[CrossRef](#)]
30. Türkes, M.C.; Oncioiu, I.; Aslam, H.D.; Marin-Pantelescu, A.; Topor, D.I.; Căpușneanu, S. Drivers and Barriers in Using Industry 4.0: A Perspective of SMEs in Romania. *Processes* **2019**, *7*, 153. [[CrossRef](#)]
31. Toivanen, J.; Kah, P.; Martikainen, J. Quality Requirements and Conformity of Welded Products in the Manufacturing Chain in Welding Network. *Int. J. Mech. Eng. Appl.* **2015**, *3*, 109–119. [[CrossRef](#)]
32. Simeone, A.; Caggiano, A.; Boun, L.; Deng, B. Intelligent Cloud Manufacturing Platform for Efficient Resource Sharing in Smart Manufacturing Networks. *Procedia CIRP* **2019**, *79*, 233–238. [[CrossRef](#)]
33. Helo, P.; Hao, Y.; Toshev, R.; Boldosova, V. Cloud Manufacturing Ecosystem Analysis and Design. *Robot. Comput.-Integr. Manuf.* **2021**, *67*, 102050. [[CrossRef](#)]
34. He, B.; Bai, K.-J. Digital Twin-Based Sustainable Intelligent Manufacturing: A Review. *Adv. Manuf.* **2020**, *9*, 1–21.
35. Liu, Q.; Chen, J.; Liao, Y.; Mueller, E.; Jentsch, D.; Boerner, F.; She, M. An Application of Horizontal and Vertical Integration in Cyber-Physical Production Systems. In *Proceedings of the International Conference on Cyber-Enabled Distributed Computing and Knowledge Discovery, Xi'an, China, 17–19 September 2015*; pp. 110–113.
36. Wen, D.; Sun, X.; Yan, D. The Quality Movement: Where Are We Going? Past, Present and Future. *Total Qual. Manag. Bus. Excell.* **2020**, 1–21. [[CrossRef](#)]
37. ISO. *6520-1:2007 Welding and Allied Processes—Classification of Geometric Imperfections in Metallic Materials—Part 1: Fusion Welding*; ISO—International Organization for Standardization: Geneva, Switzerland, 2007.
38. EN-ISO. *13919-1:2019 Electron and Laser-Beam Welded Joints—Requirements and Recommendations on Quality Levels for Imperfections—Part 1: Steels, Nickel, Titanium and Their Alloys*; ISO—International Organization for Standardization: Geneva, Switzerland, 2019.
39. ISO. *13919-2:2021 Electron and Laser-Beam Welded Joints—Requirements and Recommendations on Quality Levels for Imperfections—Part 2: Aluminium, Magnesium and Their Alloys and Pure Copper*; ISO—International Organization for Standardization: Geneva, Switzerland, 2021.
40. Lippold, J.C. Solidification Behavior and Cracking Susceptibility of Pulsed-Laser Welds in Austenitic Stainless-Steels. *Weld. J. Incl. Weld. Res. Suppl.* **1994**, *73*, S129–S139.
41. Coroado, J.; Ganguly, S.; Suder, W.J.; Williams, S.; Meco, S.; Pardal, G. Selection of Processing Parameters in Laser Microwelding. Part 1: Continuous Wave (CW) Mode. *Lasers Eng.* **2020**, *46*, 265–284.
42. Xu, J.; Rong, Y.; Huang, Y.; Wang, P.; Wang, C. Keyhole-Induced Porosity Formation During Laser Welding. *J. Mater. Process. Technol.* **2018**, *252*, 720–727. [[CrossRef](#)]
43. Svenungsson, J.; Choquet, I.; Kaplan, A.F.H. Laser Welding Process—A Review of Keyhole Welding Modelling. *Phys. Procedia* **2015**, *78*, 182–191. [[CrossRef](#)]
44. Zhang, Y.; Gao, X.; You, D.; Ge, W. A Low-Cost Welding Status Monitoring Framework for High-Power Disk Laser Welding. *IEEE Access* **2019**, *7*, 17365–17376. [[CrossRef](#)]
45. De Bono, P.; Allen, C.; D'Angelo, G.; Cisi, A. Investigation of Optical Sensor Approaches for Real-Time Monitoring during Fibre Laser Welding. *J. Laser Appl.* **2017**, *29*, 022417. [[CrossRef](#)]
46. Sibillano, T.; Ancona, A.; Berardi, V.; Lugarà, M. A Real-Time Spectroscopic Sensor for Monitoring Laser Welding Processes. *Sensors* **2009**, *9*, 3376–3385. [[CrossRef](#)] [[PubMed](#)]
47. Mrňa, L.; Šarbort, M.; Řeřucha, Š.; Jedlička, P. Correlation between the Keyhole Depth and the Frequency Characteristics of Light Emissions in Laser Welding. *Phys. Procedia* **2013**, *41*, 469–477. [[CrossRef](#)]
48. Hollatz, S.; Hummel, M.; Jaklen, L.; Lipnicki, W.; Olowinsky, A.; Gillner, A. Processing of Keyhole Depth Measurement Data during Laser Beam Micro Welding. *Proc. Inst. Mech. Eng. Part L J. Mater. Des. Appl.* **2020**, *234*, 722–731.
49. Luo, Y.; Zhu, L.; Han, J.; Xie, X.; Wan, R.; Zhu, Y. Study on the Acoustic Emission Effect of Plasma Plume in Pulsed Laser Welding. *Mech. Syst. Signal Process.* **2019**, *124*, 715–723. [[CrossRef](#)]

50. Schmidt, L.; Römer, F.; Böttger, D.; Leinenbach, F.; Straß, B.; Wolter, B.; Schricker, K.; Seibold, M.; Bergmann, J.P.; Del Galdo, G. Acoustic Process Monitoring in Laser Beam Welding. *Procedia CIRP* **2020**, *94*, 763–768. [[CrossRef](#)]
51. Kuo, B.-S.; Lu, M.-C. Analysis of a Sound Signal for Quality Monitoring in Laser Microlap Welding. *Appl. Sci.* **2020**, *10*, 1934. [[CrossRef](#)]
52. Wasmer, K.; Le-Quang, T.; Meylan, B.; Vakili-Farahani, F.; Olbinado, M.P.; Rack, A.; Shevchik, S.A. Laser Processing Quality Monitoring by Combining Acoustic Emission and Machine Learning: A High-Speed X-ray Imaging Approach. *Procedia CIRP* **2018**, *74*, 654–658. [[CrossRef](#)]
53. Shevchik, S.; Le, Q.T.; Meylan, B.; Wasmer, K. Acoustic Emission for in Situ Monitoring of Laser Processing. In Proceedings of the 33rd European Conference on Acoustic Emission Testing, Senlis, France, 12–14 September 2018.
54. Cai, W.; Wang, J.; Zhou, Q.; Yang, Y.; Jiang, P. Equipment and Machine Learning in Welding Monitoring: A Short Review. In Proceedings of the 5th International Conference on mechatronics and robotics engineering, Rome, Italy, 16–19 February 2019; pp. 9–15.
55. Zhang, B.; Hong, K.-M.; Shin, Y.C. Deep-Learning-Based Porosity Monitoring of Laser Welding Process. *Manuf. Lett.* **2020**, *23*, 62–66. [[CrossRef](#)]
56. Fan, X.; Gao, X.; Liu, G.; Ma, N.; Zhang, Y. Research and Prospect of Welding Monitoring Technology Based on Machine Vision. *Int. J. Adv. Manuf. Technol.* **2021**, *115*, 3365–3391. [[CrossRef](#)]
57. Chandrasekhar, N.; Vasudevan, M.; Bhaduri, A.K.; Jayakumar, T. Intelligent Modeling for Estimating Weld Bead Width and Depth of Penetration from Infra-Red Thermal Images of the Weld Pool. *J. Intell. Manuf.* **2015**, *26*, 59–71. [[CrossRef](#)]
58. Weberpals, J.; Hermann, T.; Berger, P.; Singpiel, H. Utilisation of Thermal Radiation for Process Monitoring. *Phys. Procedia* **2011**, *12*, 704–711. [[CrossRef](#)]
59. Chen, Z.; Gao, X. Detection of Weld Pool Width Using Infrared Imaging During High-Power Fiber Laser Welding of Type 304 Austenitic Stainless Steel. *Int. J. Adv. Manuf. Technol.* **2014**, *74*, 1247–1254. [[CrossRef](#)]
60. Cai, W.; Wang, J.; Jiang, P.; Cao, L.; Mi, G.; Zhou, Q. Application of Sensing Techniques and Artificial Intelligence-Based Methods to Laser Welding Real-Time Monitoring: A Critical Review of Recent Literature. *J. Manuf. Syst.* **2020**, *57*, 1–18. [[CrossRef](#)]
61. You, D.; Gao, X.; Katayama, S. Multiple-Optics Sensing of High-Brightness Disk Laser Welding Process. *Ndt E. Int.* **2013**, *60*, 32–39. [[CrossRef](#)]
62. Benakis, M.; Du, C.; Patran, A.; French, R. Welding Process Monitoring Applications and Industry 4.0. In Proceedings of the 2019 IEEE 15th International Conference on Automation Science and Engineering (CASE), Vancouver, BC, Canada, 22–26 August 2019; pp. 1755–1760.
63. Artinov, A.; Bakir, N.; Bachmann, M.; Gumenyuk, A.; Rethmeier, M. Weld Pool Shape Observation in High Power Laser Beam Welding. *Procedia CIRP* **2018**, *74*, 683–686. [[CrossRef](#)]
64. Huang, Y.; Xu, S.; Yang, L.; Zhao, S.; Liu, Y.; Shi, Y. Defect Detection During Laser Welding Using Electrical Signals and High-Speed Photography. *J. Mater. Process. Technol.* **2019**, *271*, 394–403. [[CrossRef](#)]
65. Zhao, S.; Yang, L.; Huang, Y.; Zhao, D.; Xu, S. A Study on Welding Mode Transition by Electrical Detection of Laser-Induced Plasma at Varying Energy Levels. *Int. J. Adv. Manuf. Technol.* **2019**, *104*, 893–906. [[CrossRef](#)]
66. Zhang, Y.; You, D.; Gao, X.; Zhang, N.; Gao, P.P. Welding Defects Detection Based on Deep Learning with Multiple Optical Sensors During Disk Laser Welding of Thick Plates. *J. Manuf. Syst.* **2019**, *51*, 87–94. [[CrossRef](#)]
67. Ahmed, F.; Jannat, N.-E.; Schmidt, D.; Kim, K.-Y. Data-Driven Cyber-Physical System Framework for Connected Resistance Spot Welding Weldability Certification. *Robot. Comput.-Integr. Manuf.* **2021**, *67*, 102036. [[CrossRef](#)]
68. Martinez, R.T.; Alfaro, S.C.A. Data Analysis and Modeling Techniques of Welding Processes: The State-of-the-Art. In *Welding-Modern Topics*; IntechOpen: London, UK, 2020.
69. Xu, Z.; Dang, Y.; Munro, P. Knowledge-Driven Intelligent Quality Problem-Solving System in the Automotive Industry. *Adv. Eng. Inform.* **2018**, *38*, 441–457. [[CrossRef](#)]
70. Svetashova, Y.; Zhou, B.; Pychynski, T.; Schmidt, S.; Sure-Vetter, Y.; Mikut, R.; Kharlamov, E. Ontology-Enhanced Machine Learning: A Bosch Use Case of Welding Quality Monitoring. In *International Semantic Web Conference*; Springer International Publishing: Cham, Switzerland, 2020; pp. 531–550.
71. Cao, L.; Zhang, L.; Wu, Y. A Data-Driven Model for Weld Bead Monitoring During the Laser Welding Assisted by Magnetic Field. *Int. J. Adv. Manuf. Technol.* **2020**, *107*, 475–487. [[CrossRef](#)]
72. Hinchy, E.; O’Dowd, N.; McCarthy, C.T. Using Open-Source Microcontrollers to Enable Digital Twin Communication for Smart Manufacturing. *Procedia Manuf.* **2019**, *38*, 1213–1219. [[CrossRef](#)]
73. Costa, F.S.; Nassar, S.M.; Gusmeroli, S.; Schultz, R.; Conceição, A.G.; Xavier, M.; Hessel, F.; Dantas, M.A. FASTEN IIoT: An Open Real-Time Platform for Vertical, Horizontal and End-to-End Integration. *Sensors* **2020**, *20*, 5499. [[CrossRef](#)]
74. Forcina, A.; Falcone, D. The Role of Industry 4.0 Enabling Technologies for Safety Management: A Systematic Literature Review. *Procedia Comput. Sci.* **2021**, *180*, 436–445. [[CrossRef](#)]
75. Csalódi, R.; Süle, Z.; Jaskó, S.; Holczinger, T.; Abonyi, J. Industry 4.0-Driven Development of Optimization Algorithms: A Systematic Overview. *Complexity* **2021**, *2021*, 6621235. [[CrossRef](#)]
76. ISO. *ISO 15607:2019 Specification and Qualification of Welding Procedures for Metallic Materials—General Rules*; ISO—International Organization for Standardization: Geneva, Switzerland, 2019.

77. Pereira, A.B.; de Melo, F.J.M.Q. Quality Assessment and Process Management of Welded Joints in Metal Construction—A Review. *Metals* **2020**, *10*, 115. [[CrossRef](#)]
78. Öberg, A.E.; Åstrand, E. Variation in Welding Procedure Specification Approach and Its Effect on Productivity. *Procedia Manuf.* **2018**, *25*, 412–417. [[CrossRef](#)]
79. ISO. 14732:2013 *Welding Personnel—Qualification Testing of Welding Operators and Weld Setters for Mechanized and Automatic Welding of Metallic Materials*; ISO—International Organization for Standardization: Geneva, Switzerland, 2013.
80. Bousdekis, A.; Lepenioti, K.; Apostolou, D.; Mentzas, G. A Review of Data-Driven Decision-Making Methods for Industry 4.0 Maintenance Applications. *Electronics* **2021**, *10*, 828. [[CrossRef](#)]
81. Qin, S.-F.; Cheng, K. Future Digital Design and Manufacturing: Embracing Industry 4.0 and Beyond. *Chin. J. Mech. Eng.* **2017**, *30*, 1047–1049. [[CrossRef](#)]
82. Asif, M. Are QM Models Aligned with Industry 4.0? A Perspective on Current Practices. *J. Clean. Prod.* **2020**, *258*, 120820.
83. Emblemståg, J. On Quality 4.0 in Project-Based Industries. *TQM J.* **2020**, *32*, 725–739. [[CrossRef](#)]
84. ISO. 14731:2019 *Welding Coordination—Tasks and Responsibilities*; ISO—International Organization for Standardization: Geneva, Switzerland, 2019.
85. Jiao, R.; Commuri, S.; Panchal, J.; Milisavljevic-Syed, J.; Allen, J.K.; Mistree, F.; Schaefer, D. Design Engineering in the Age of Industry 4.0. *J. Mech. Des.* **2021**, *143*, 070801. [[CrossRef](#)]
86. Ibarra, D.; Ganzarain, J.; Igartua, J.I. Business Model Innovation through Industry 4.0: A Review. *Procedia Manuf.* **2018**, *22*, 4–10. [[CrossRef](#)]
87. Opresnik, D.; Taisch, M. The Value of Big Data in Servitization. *Int. J. Prod. Econ.* **2015**, *165*, 174–184. [[CrossRef](#)]
88. Bashir, M.; Verma, R. Why Business Model Innovation Is the New Competitive Advantage. *IUP J. Bus. Strategy* **2017**, *14*, 7–17.
89. Magretta, J. *Why Business Models Matter*; Harvard Business School Online: Boston, MA, USA, 2002.