

We are IntechOpen, the world's leading publisher of Open Access books Built by scientists, for scientists

5,500

Open access books available

136,000

International authors and editors

170M

Downloads

Our authors are among the

154

Countries delivered to

TOP 1%

most cited scientists

12.2%

Contributors from top 500 universities



WEB OF SCIENCE™

Selection of our books indexed in the Book Citation Index
in Web of Science™ Core Collection (BKCI)

Interested in publishing with us?
Contact book.department@intechopen.com

Numbers displayed above are based on latest data collected.
For more information visit www.intechopen.com



Electrical Equivalent Circuit Models of Lithium-ion Battery

Rushali R. Thakkar

Abstract

Modelling helps us to understand the battery behaviour that will help to improve the system performance and increase the system efficiency. Battery can be modelled to describe the V-I Characteristics, charging status and battery's capacity. It is therefore necessary to create an exact electrical equivalent model that will help to determine the battery efficiency. There are different electrical models which will be discussed and examined along with the benefits and demerits. A systematic comparison and analysis using simulation will help us to select an ideal model which will suit best to a specific application.

Keywords: battery, lithium-ion batteries, battery modelling, state of charge, electrical equivalent, simulation

1. Introduction

Renewable energies play a major role in the power quality applications of emerging technologies. Batteries are considered as one of the most important amongst the component. Batteries are energy storage devices that can be utilised in a variety of applications and range in power from low to high. Batteries are connected in series and parallel to match the load requirements. The advantages of lithium-ion batteries include their light weight, high energy density, and low discharge rates. They're commonly seen in high-power applications like electric vehicles and hybrids. Lithium-ion batteries have a terminal voltage of 3-4.2 volts and can be wired in series or parallel to satisfy the power and energy demands of high-power applications. Battery models are important because they predict battery performance in a system, designing the battery pack and also help anticipate the efficiency of a system [1, 2].

2. Existing electrical equivalent battery models

The mathematical relationship between the elements of Lithium-ion batteries and their V-I characteristics, state of charge (SOC), internal resistance, operating cycles, and self-discharge is depicted in a Lithium-ion battery model. The equivalent circuit model of a Lithium-ion battery is a performance model that uses one or more parallel combinations of resistance, capacitance, and other circuit components to construct an electric circuit to replicate the dynamic properties of Lithium-ion batteries. Time domain analysis is used to produce the most often utilised electrical

equivalent models. The simplest model equation for battery model can be represented by Open Circuit Voltage (OCV)

$$v(t) = OCV \quad (1)$$

SOOC of a cell is 100% when cell is fully charged and SOC is 0% when cell is fully discharged. The amount of charge removed from 100–0% is the total capacity measured in Ah or mAh.

Following are the models used for Lithium-ion battery to determine the performance on the system [3].

2.1 Simple battery model Rint model

Figure 1 illustrates the most widely used battery model. It consists of an ideal battery with open circuit voltage (OCV) V_0 , a constant equivalent internal resistance R_{int} , and $v(t)$ as the terminal voltage. When completely charged, the terminal voltage $v(t)$ may be determined by measuring the open circuit voltage, and R_{int} can be determined by connecting a load and detecting both the terminal voltage and current.

SOC is represented as $z(t)$ of a cell is 100% when cell is fully charged and SOC is 0% when cell is fully discharged. The amount of charge removed from 100–0% is the total capacity (Q) measured in Ah or mAh.

$$v(t) = OCV(z(t)) - i(t)R_{int} \quad (2)$$

$$\frac{dz}{dt} = -\frac{i(t)}{Q} \quad (3)$$

$$z(t) = z(t_0) - Q \int_{t_0}^t i(T)dT \quad (4)$$

At the point when a battery is completely charged, its Open Circuit Voltage is higher than when it is discharged. The Rint model appears to be relatively simple, however it ignores the variable nature of the internal resistance related to temperature, state of charge, and electrolytic concentration.

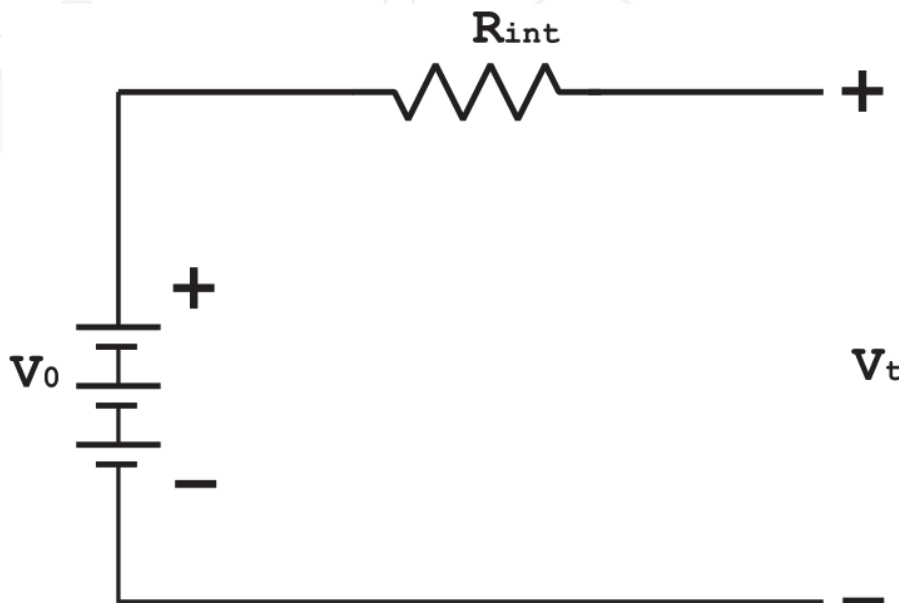

Figure 1.
Resistive Thevenin battery model.

2.2 Resistive Thevenin battery model

Figure 2 shows the circuit schematic for the resistive Thevenin battery model. This model has two types of internal resistances, R_0 and R_1 , which are connected to the charging and discharging properties of the battery, respectively. Electrical and non-electrical losses are modelled by the internal resistances R_0 and R_1 . Diffusion Voltages also can be closely found using 1 or more RC parallel branches. The model gives better results than R_{int} model, however transient conditions like the capacitance effect are not considered. As a result, this model is non-dynamic and unsuitable for applications involving electric vehicles and electric hybrids [4–8].

In relaxation mode, voltage gradually reduces to zero, this is termed as diffusion voltage which can be closely approximated using parallel RC branches (**Figure 3**) [4, 5].

$$v(t) = OCV(z(t)) - i(t)R_{int} - V_{c1}(t) \quad (5)$$

2.3 An accurate electrical battery model

An Accurate Electrical Battery Model, models the battery capacity, charging state, and run time using a capacitor and a current controlled source. The circuit takes into account the battery life time as well as the slow and fast transient response. A voltage controlled voltage source that is a function of state of charge is used to overcome the barrier between SOC and OCV (**Figure 4**) [1].

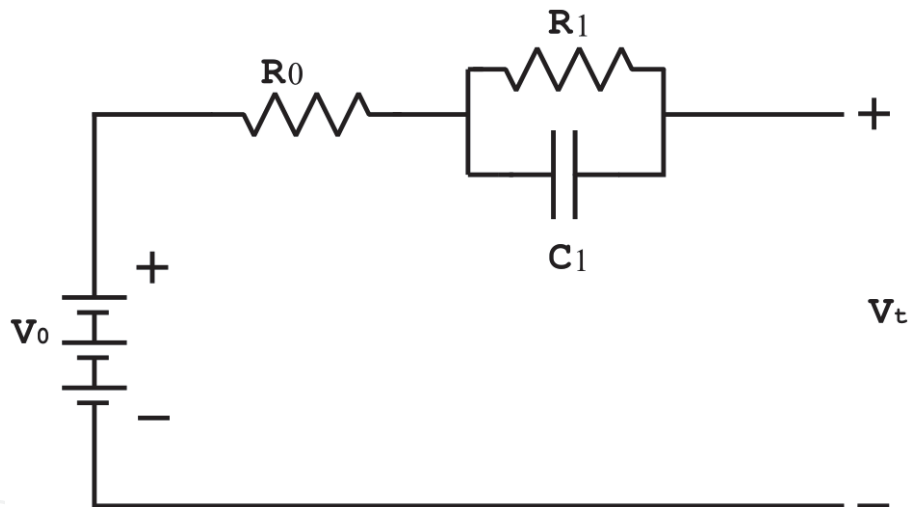

Figure 2.
Thevenin battery model with 1 RC branch.

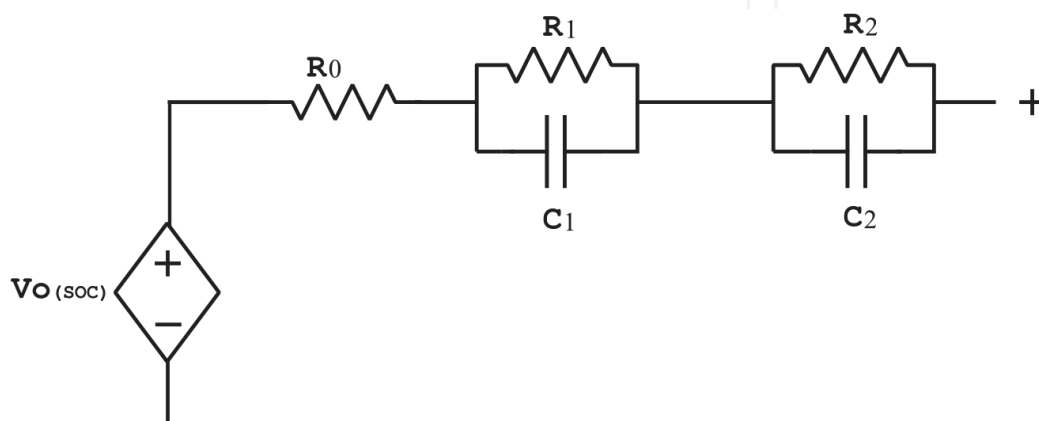

Figure 3.
Thevenin battery model with 2 RC branches.

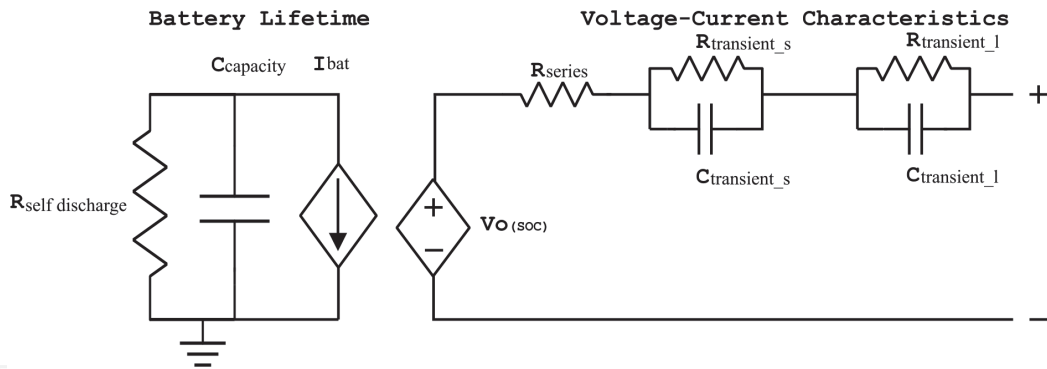

Figure 4. Accurate electrical battery model.

S. No.	Battery model	Features
1	R_{int} model	Model is static.
2	Thevenin electric model	Does not consider the dependency of state of charge.
3	Second order RC Thevenin model	Model does not consider the parameters like temperature and capacity.
4	Accurate electrical equivalent model	Model considers the battery life time.

Table 1. Comparison of electrical equivalent battery models [8].

Capacity	Nominal capacity: 2600 mAh (0.52 A discharge, 2.75 V)
Nominal voltage	3.7 V
Internal impedance	$\leq 70 \text{ m}\Omega$
Discharge cut off voltage	3.0 V
Maximum charge voltage	$4.20 \pm 0.05 \text{ V}$
Standard charge discharge current	0.52 A
Rapid charge discharge current	1.3 A
Maximum pulse discharge current	2.6 A

Table 2. Battery model specifications LIR18650 mAh.

2.4 Models of electrical equivalent batteries

Table 1 gives the different Electrical equivalent circuit models along with its important features so that it will be useful to predict the performance of the battery and for which application the battery can be used for.

2.5 Electrical characteristics of lithium-ion battery

Lithium-ion battery specifications used for battery model: LIR18650 mAh are given in the following **Table 2** [8].

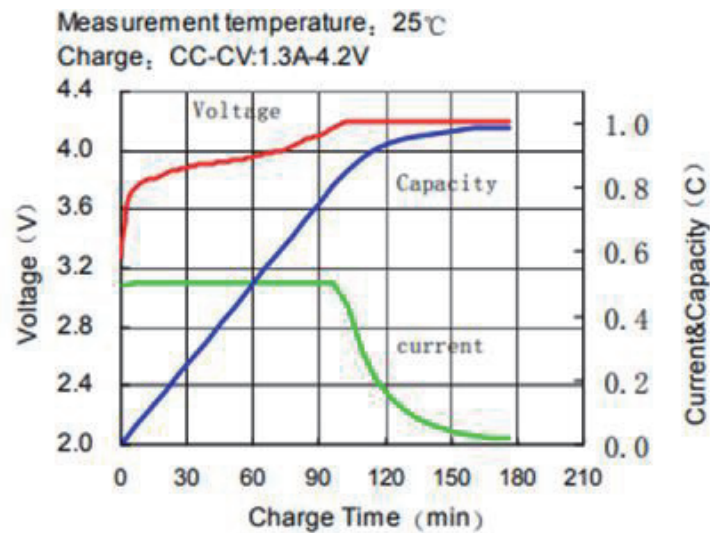

Figure 5.
 Rate charge characteristics.

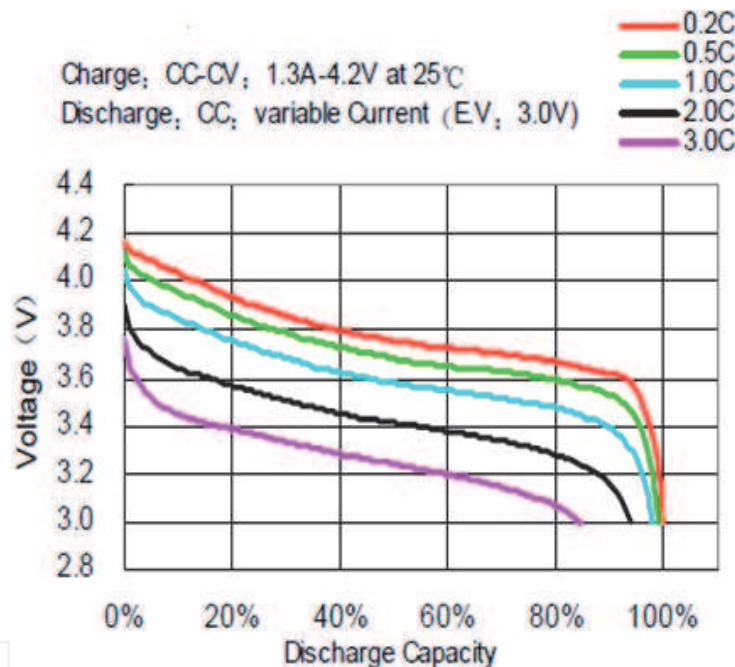

Figure 6.
 Rate discharge characteristics.

2.6 Charging and discharging characteristics

Figures 5 and 6 shows the rate charge and discharge characteristics of the battery Model LIR18650 2600 mAh. The battery charges with Constant Current Constant Voltage mode. The battery is charged at a constant current until it reaches 4.2 volts, then it is charged at a constant voltage until the current drops to zero [8]. The charging time of battery can be calculated as the ratio of battery Ah to the charging current.

3. Simulation results and discussion

M file is created in Matlab to simulate the model's charging and discharging curves. The generalised model for lithium-ion batteries uses the equations below [7, 8].

Discharge Model ($i^* > 0$)

$$f1(it, i^*, i) = E0 - K \cdot \frac{Q}{Q - it} \cdot i^* - K \cdot \frac{Q}{Q - it} + A \cdot \exp(-B \cdot it) \quad (6)$$

Charge Model ($i^* < 0$)

$$f1(it, i^*, i) = E0 - K \cdot \frac{Q}{it + 0.1 \cdot Q} \cdot i^* - K \cdot \frac{Q}{Q - it} + A \cdot \exp(-B \cdot it); \quad (7)$$

$E0$ is constant voltage (V), K is polarisation constant in (Ah^{-1}), i^* is low frequency current dynamics, Q is maximum battery capacity (Ah), A is exponential voltage (V), B is exponential capacity (Ah^{-1}), it is extracted capacity (Ah).

The implementation of the generalised model in MATLAB shows that the characteristics developed by mathematical electrical model of battery in Matlab and are close to the actual characteristics of Lithium-ion Battery Model LIR18650 2600 mAH [8].

4. Conclusion

Being a static model, the Rint model does not account for the battery's charging and discharging properties. Thevenin's electric model (1RC) ignores dynamic behaviour and neglects to account for state of charge dependency. 2 RC branches would be closer to match the data at the beginning of the transient. 3RC branches can be chosen as a compromise between complexity of model and its fidelity. Various electrical equivalent models are studied along with its different features in the existing models.

Author details

Rushali R. Thakkar
Sardar Patel Institute of Technology, Mumbai, India

*Address all correspondence to: rushalithakkar@gmail.com

IntechOpen

© 2021 The Author(s). Licensee IntechOpen. This chapter is distributed under the terms of the Creative Commons Attribution License (<http://creativecommons.org/licenses/by/3.0>), which permits unrestricted use, distribution, and reproduction in any medium, provided the original work is properly cited. 

References

[1] Min Chen and Gabriel A. Rinc'on-Mora. Accurate electrical battery model capable of predicting runtime and I–V performance. *IEEE Transactions on Energy Conversion* 2006;21(2).

[2] Xiaoqiang Zhang, Weiping Zhang, and Geyang Lei. A review of Li-ion battery equivalent circuit models. *Transactions on Electrical and Electronic Materials* 2016;17(6):311-316.

[3] Low Wen Yao, J. A. Aziz, Pui Yee Kong, and N. R. N. Idris. Modeling of lithium-ion battery using MATLAB/Simulink. In: *Proceedings of Conference of the IEEE Industrial Electronics Society*. Vienna, pp. 1729-1734, Nov. 2016.

[4] Barcellona Simone and Piegari Luig. Lithium ion battery models and parameter identification techniques. *Energies* 2017;10.

[5] Zhang Lijun, Peng Hui, Ning Zhansheng, Zhongqiang Mu, and Sun Changyan. Comparative research on RC equivalent circuit models for lithium-ion batteries of electric vehicles. *Applied Sciences* 2017;7.

[6] Hyun You, Jun Bae, So Cho, Jong Lee, and Se-Hun Kim. Analysis of equivalent circuit models in lithium-ion batteries. *AIP Advances* 2018;8.

[7] Haizhou Zhai. Modeling of lithium-ion battery for charging/discharging characteristics based on circuit model. *International Journal of Online Engineering*, 2017;13(6):86-95.

[8] R. R. Thakkar, Y. S. Rao, and R. R. Sawant. Performance Analysis of electrical equivalent circuit models of lithium-ion battery. In: *2020 IEEE Pune Section International Conference (PuneCon)*, 2020, pp. 103-107. DOI: 10.1109/PuneCon50868.2020.9362386