

We are IntechOpen, the world's leading publisher of Open Access books Built by scientists, for scientists

5,600

Open access books available

137,000

International authors and editors

170M

Downloads

Our authors are among the

154

Countries delivered to

TOP 1%

most cited scientists

12.2%

Contributors from top 500 universities



WEB OF SCIENCE™

Selection of our books indexed in the Book Citation Index
in Web of Science™ Core Collection (BKCI)

Interested in publishing with us?
Contact book.department@intechopen.com

Numbers displayed above are based on latest data collected.
For more information visit www.intechopen.com



A Zero-Waste Process for the Treatment of Spent Potliner (SPL) Waste

*Samir I. Abu-Eishah, Manal D.M. Raheem,
Fatma A.S. Aljasmi, Fatima M.O. Alameri,
Amna G.R. Alblooshi and Intesar F.R. Alnahdi*

Abstract

This work presents a deep analyses of an environmentally friendly process to recover all valuable minerals contained in the spent potliner (SPL) such as graphite carbon and aluminum fluoride (AlF_3) and production of sodium sulfate (Na_2SO_4) and gypsum (CaSO_4) when H_2SO_4 is used as the leaching agent. The level of emission of hazardous gases such as HCN (weak acid) and HF are minimized by direct scrubbing of the HCN in aqueous AgNO_3 solution to produce a stable silver cyanide (AgCN) product. The HF can be recovered as a liquid by condensation and used within the process and/or in production of metal fluorides such as the highly-soluble potassium fluoride (KF); a main source of fluoride in industry. Almost pure CO_2 gas is also recovered from the process gas streams.

Keywords: aluminum production, spent potliner (SPL), leaching by H_2SO_4 , aluminum fluoride recovery, graphite carbon recovery, zero-waste process

1. Introduction

SPL is a hazardous solid waste material produced in the aluminum smelting industry [1]. It is generated when the graphite carbon and the refractory lining of the aluminum electrolytic cell reach the end of their useful life. After about 5 to 8 years of smelter operation, the cathode liner materials deteriorate and affect the aluminum electrolytic cell performance thus need to be replaced. Various factors contribute to cell lining degradation, for example, mechanical stress, electrolyte penetration and side reactions [2].

About 20 to 25 kg of SPL is generated per each ton produced of primary aluminum [3]. Worldwide aluminum production was about 63.6 million tons in 2018, generating about 1.4 million tons of SPL [4], which is a real environmental burden to the aluminum industry, and these figures are subject to increase [5]. In 2018, the United Arab Emirates (UAE) produced 2.64 million tons of aluminum and 29,040 tons of SPL (~ 11 kg SPL/ton aluminum). This SPL is distributed to the UAE cement industry for use as a feedstock and a fuel alternative [4].

SPL is classified as a hazardous waste by the US Environmental Protection Agency (EPA) since it contains significant amounts of toxic fluoride and cyanide

compounds (in addition to a trace amounts of polycyclic aromatic hydrocarbons, PAH), which can have adverse impacts on the environment if not adequately disposed. Cyanides are highly toxic and must be destroyed or removed from the SPL before its disposal or reuse. SPL has a high pH value due to the presence of alkali metals and oxides that make it corrosive.

Some of the SPL constituents react with water and produce flammable, toxic and explosive gases such as H_2 , NH_3 and CH_4 . Thus, SPL disposal is becoming one of the largest environmental concerns and the SPL stored around the world needs to be safely disposed.

Both the aluminum and fluoride species are very valuable materials and need to be recovered, preferably in the form of aluminum fluoride (AlF_3) that can be recycled to the aluminum smelting plant to produce elemental aluminum. The graphite carbon also needs to be recovered and reused at least in manufacturing of cathodes for the aluminum electrolytic cells.

In this work, we are developing an environmentally-friendly process, while properly, safely and effectively disposing the other constituents of the SPL. In this process we aim to recover the aluminum and fluoride species, the graphite carbon, in addition to other side products, that at the end leads to zero-waste. In the discussion below, equations numbering (i) within the text, for $i = 1, \dots, n$, stands for the final form of the reactions taking place during the leaching process with H_2SO_4 as well as the equations used in the process analyses.

Also, the numbering appearing in the tables stands for chemical reactions within the cathode (**Table 1**), potential gases that might evolve from the SPL reactive species when hydrolyzed (**Table 4**), other potential reactions (**Table A.5**), and SPL trace constituents' reactions with H_2SO_4 (**Table A.6**).

1.1 SPL compounds generated during the aluminum smelting process

The aluminum smelting process involves electrolysis of alumina (Al_2O_3), dissolved in cryolite (Na_3AlF_6), in a cell having graphite electrodes and linings used to transmit current from the cathodic collector bar and to contain the molten Aluminum product and the alumina-containing electrolyte.

New lining materials of aluminum electrolytic cells are made from clean and virgin graphite materials. The cathode graphite material is typically 15–25% porous, but it gets penetrated by bath materials after the start of electrolysis [6]. Penetration is initiated by the metallic sodium $Na(c)$, followed by the electrolyte [7]. The chemical reactions within the cathode result in the formation of various carbides, nitrides, cyanides, and others within the pot linings (refractory, cathodes, and sidewalls) [8].

The spent cathode contains a lot of fluoride and cyanide. During the extended operation of the electrolytic cell, fluoride is brought in by AlF_3 and Na_3AlF_6 and is absorbed into the cell linings. Cyanides are produced by the chemical reaction between metallic sodium (from cryolite), atmospheric nitrogen penetrating into the cathode carbon through openings in the potshell and through the cathode carbon itself. Indicative examples of the chemical reactions that take place within the cathode are shown in **Table 1** along with their calculated change in the heat of reaction (ΔH_R) and change in the Gibbs free energy of reaction (ΔG_R) (using HSC Chemistry 6.1 software) at 30°C.

1.2 SPL composition

The SPL composition varies from one plant (or from one cell) to another [9]. Various factors contribute to this variation, some of which include the cell design, cathode materials, side reactions, operation time, shutdown time and electrolyte

#	Chemical Reaction	ΔH_R , kJ/mol	ΔG_R , kJ/mol
Na(c), CO, Na ₂ CO ₃ , and NaCN formation reactions:			
1	6NaF + Al → 3Na(c) + Na ₃ AlF ₆	160.1	111.8 ^b
2	O ₂ (g) + 2C → 2CO(g)	-221.2	-275.4
3	3CO(g) + 2Na(c) → Na ₂ CO ₃ + 2C	-814.9	-628.7
4	2Na(c) + 2C + N ₂ (g) → 2NaCN	-196.6	-155.1
NaAlSiO ₄ (Nepheline) formation reaction at low SiO ₂ /Al ₂ O ₃ ratios:			
5	6NaF + 3SiO ₂ + 2Al ₂ O ₃ → 3NaAlSiO ₄ + Na ₃ AlF ₆	-46.9	-43.1
NaAlSi ₃ O ₈ (Albite) formation reaction at high SiO ₂ /Al ₂ O ₃ ratios:			
6	6NaF + 9SiO ₂ + 2Al ₂ O ₃ → 3NaAlSi ₃ O ₈ + Na ₃ AlF ₆	-80.8	-94.4
Reactions that contribute to changes in Na ₃ AlF ₆ (cryolite) ratio:			
7	Na ₃ AlF ₆ + 2CO(g) + 6Na(c) → NaAlO ₂ + 6NaF + 2C	-973.2	-827.4
8	Na ₃ AlF ₆ + 2Na ₂ CO ₃ + 2C → NaAlO ₂ + 6NaF + 4CO(g)	549.4	354.9 ^c
9	2Na ₃ AlF ₆ + N ₂ (g) + 6Na(c) → 2AlN + 12NaF	-742	-646.6
10	Na ₃ AlF ₆ + NaCN + 2Na(c) → AlN + 6NaF + C(s)	-275.9	-248.9
Other NaCN consuming reactions:			
11 ^a	2Al ₂ O ₃ + NaCN + 2Na(c) → 3NaAlO ₂ + AlN + C	-294.1	-247.3
Additional NaAlO ₂ formation reactions:			
12	AlN + 2CO(g) + Na(c) → NaAlO ₂ + 2C + 5 N ₂ (g)	-1204.4	-1008.1
13 ^a	Al ₂ O ₃ + CO(g) + 2Na(c) → 2 NaAlO ₂ + C	-495.7	-412.8
Al ₄ C ₃ formation reactions:			
14	4Na ₃ AlF ₆ + 12Na(c) + 3C → Al ₄ C ₃ + 24NaF	-856.1	-650.5
15 ^a	8Al ₂ O ₃ + 3C + 12Na(c) → 12NaAlO ₂ + Al ₄ C ₃	-499.9	-343.2
16	4Al + 3C → Al ₄ C ₃	-215.9	-203.3
17	2Al + N ₂ (g) → 2AlN	-636.5	-573.3

^aThe alumina data are for α -Al₂O₃ since the data for the actual similar β -Al₂O₃ (Na₂O·11Al₂O₃) compound is not available. The Na (l) data was used in the equations that require Na(c) data, which means that the actual ΔG_R is slightly more negative when Na(c) is on the right side of the equation and slightly more positive when Na(c) is on the left side of the equation.

^bOnly -ve at T > 700°C.

^cOnly -ve at T ≥ 650°C.

Table 1. Chemical reactions within the cathode [6, 8] and their calculated ΔH_R and ΔG_R at 30°C.

composition [10]. Most of the chemical components of the SPL are direct constituents of the electrolytic bath that infuse the carbon cathode and subsequently the refractory lining. While some of the phases are additives to the electrolytic bath, others are the result of side reactions [11].

Typical composition ranges of the SPL constituents are shown in **Table 2**, from which the SPL contains about 6.2 wt% Al, 17.5 wt% F, 39 wt% C (as graphite), and 21 wt% Na [12].

Table 3 shows the main elemental composition of the SPL along with the major phases or compounds of these elements. For example, the major forms of cyanides are identified as sodium cyanide (NaCN), sodium ferrocyanide Na₄Fe(CN)₆ and sodium ferricyanide Na₃Fe(CN)₆. Fluorides are mostly found in the form of sodium fluoride (NaF). Other reported forms of fluoride include sodium aluminum fluoride (Na₃AlF₆) and calcium fluoride (CaF₂) [13].

Compound	wt% (low)	wt% (high)
NaF	8.0	16.0
Na ₂ CO ₃	6.5	6.5
NaCN	0.1	2.0
NaAlO ₂	5.0	10.0
C	20.0	40.0
Na ₃ AlF ₆	7.0	14.0
CaF ₂	3.0	7.0
NaAlSiO ₄	3.0	7.0

Table 2.
Predominant SPL compounds and their composition ranges [12].

Element	Composition range, wt%	Major phases/compounds
C	9.6–50	Graphite carbon
Na	7.0–20	NaF, Na ₃ AlF ₆
Al	4.7–22.1	Al metal, α-Al ₂ O ₃ , others
F	9.7–18.9	NaF, Na ₃ AlF ₆ , CaF ₂
Ca	1.1–2.9	CaF ₂
Li	0.3–1.1	LiF, Li ₃ AlF ₆
Mg	0.3–0.9	MgF ₂
Si	0.0–2.3	Refractory SiO ₂ , NaAlSiO ₄
Fe	0.3–2.1	Fe ₂ O ₃
S	0.1–0.3	Gypsum (CaSO ₄)
Ti	0.15–0.24	TiB ₂
CN	0.02–0.44	NaCN, Na ₄ Fe(CN) ₆ , Na ₃ Fe(CN) ₆

Table 3.
SPL main elements [14] and their major phases / compounds [15].

1.3 SPL properties

When the linings are removed from the pot they contain substantial amounts of sodium fluoride and sodium aluminum fluoride. In addition, the SPL contains Al metal, Na metal, Aluminum nitride (AlN), Aluminum carbide (Al₄C₃), and sodium cyanide (NaCN) that absorbs and reacts with atmospheric water (humidity) and emits hazardous gases to the atmosphere. **Table 4** shows potential gases evolved when the SPL is hydrolyzed, i.e. subjected to humidity, along with their calculated ΔH_R and ΔG_R at 30°C. However, some authors claim that reactions 19, 23 and 25 (in **Table 4**) produce Al₂O₃. However, it is well known that Al₂O₃ results from Gibbsite {Al(OH)₃} only after it is calcined (at temperatures above 400°C) [16].

Other reactions include those of ionic ferro- and ferri-cyanide with water [18]. For example,



Note: (ia) is used in the HSC database for aqueous electrolyte (neutral), which is formed from undissociated aqueous species (ions).

#	Chemical Reactions ^a	ΔH_R , kJ/mol	ΔG_R , kJ/mol
18	$\text{Al} + 3\text{H}_2\text{O} \rightarrow \text{Al}(\text{OH})_3(\text{s}) + 1.5\text{H}_2(\text{g})$	-419.5	-427.7
19	$2\text{Al} + 3\text{H}_2\text{O} \rightarrow \text{Al}_2\text{O}_3 + 3\text{H}_2(\text{g})$	-819.3	-872.3
20	$\text{Al} + \text{NaOH} + \text{H}_2\text{O} \rightarrow \text{NaAlO}_2 + 1.5\text{H}_2(\text{g})$	-422.1	-453.3
21	$2\text{Na}(\text{c}) + 2\text{H}_2\text{O} \rightarrow 2\text{NaOH} + \text{H}_2(\text{g})$	-295.6	-279.7
22	$\text{AlN} + 3\text{H}_2\text{O} \rightarrow \text{Al}(\text{OH})_3 + \text{NH}_3(\text{g})$	-147.3	-157.0
23	$2\text{AlN} + 3\text{H}_2\text{O} \rightarrow \text{Al}_2\text{O}_3 + 2\text{NH}_3(\text{g})$	-275.0	-330.8
24	$\text{Al}_4\text{C}_3 + 12\text{H}_2\text{O} \rightarrow 4\text{Al}(\text{OH})_3 + 3\text{CH}_4(\text{g})$	-1686.4	-1658.0
25	$\text{Al}_4\text{C}_3 + 6\text{H}_2\text{O} \rightarrow 2\text{Al}_2\text{O}_3 + 3\text{CH}_4(\text{g})$	-1647.1	-1691.8
26	$\text{NaCN} + 2\text{H}_2\text{O} \rightleftharpoons \text{HCOONa}(\text{ia}) + \text{NH}_3(\text{g})$	-49.9	-75.3

^aIn energy calculations: Na(l) is used instead of Na(c). (ia) is used in the HSC database for aqueous electrolyte (neutral), which is formed from undissociated aqueous species (ions).

Table 4.

Potential gases that might evolve from the SPL reactive species when hydrolyzed [7, 17] and their calculated ΔH_R and ΔG_R at 30°C.

1.4 Main products and side products of the SPL treatment

Fluoride is the main product of the various SPL treatment processes. Fluorides are used as fluoropolymers (e.g. Teflon), which is utilized as a part of an extensive variety of uses such as cosmetic and reconstructive surgeries, paints, cookware, scratching semiconductor gadgets, cleaning, etching glass and aluminum and in evacuating rust. Aluminum hydroxyfluoride (AlF_2OH) is of particular importance among the produced fluorides. It has a high market value and can be converted to aluminum fluoride (AlF_3), which is one of the important key materials for aluminum metal production and constitutes a major cost in it [19].

Carbon is the main side product recovered during the SPL treatment; over 87% of which is in the form of graphite. Graphite behaves as a non-metal and a metal because it can resist high temperatures and it is a good electrical conductor. Graphite is also good as a refractory material because of its high-temperature stability and chemical inertness thus it is used in the production of refractory bricks. Furthermore, it can be used in production of functional refractories for continuous casting of steel and as lining blocks in iron blast furnaces due to its high thermal conductivity. In high-temperature applications (e.g. arc furnaces), it is used in production of phosphorus and calcium carbide. It can also be used as anode in aqueous electrolytic production of halogens (e.g. chlorine and fluorine), cathode in the aluminum industry, or as a fuel [4]. The other compounds (e.g. CaF_2) can be used as part of the feed in cement production.

2. Recovery of fluoride values from the chemical leaching of SPL

The majority of the chemical leaching processes of the SPL targeted fluoride recovery in the form of metal fluorides such as sodium fluoride (Villiaumite, NaF), calcium fluoride (CaF_2), sodium aluminum fluorides [e.g. cryolite (Na_3AlF_6) and $5\text{NaF} \cdot 3\text{AlF}_3$ complex], aluminum fluoride (AlF_3), aluminum hydroxyfluoride (AlF_2OH) or aluminum hydroxyfluoride hydrate ($\text{AlF}_x(\text{OH})_{(3-x)} \cdot x\text{H}_2\text{O}$, $x = 1$ or 2) [19]. The most valuable fluoride among these are AlF_3 and AlF_2OH . The AlF_3 is constantly needed in aluminum smelters to maintain the cryolite balance [20].

The AlF_2OH can be easily converted to AlF_3 , for example by its reaction with HF [12]. However, NaF has a low market value since it is not consumed as much as AlF_3 in a typical smelter. The CaF_2 is also of low market value and limited quality.

Most of the AlF_3 recovery methods involve very complex and expensive processes mainly because they were not successful in precipitating AlF_3 due to its relatively high solubility in water [21]. Another problem is the AlF_3 meta-stability (200–250 g/L) which can delay its crystallization by several hours [22]. A combination of HF, fluorosilicic acid (H_2SiF_6) and ammonium bi-fluoride (NH_4HF_2) was used to precipitate AlF_3 by [23], however, these acids are highly toxic and/or expensive. In addition, calcination at 500°C to get the final AlF_3 product is required; thus, increasing the energy demand.

Leaching of the SPL CaF_2 and Na_3AlF_6 by $\text{Al}(\text{NO}_3)_3 \cdot 9\text{H}_2\text{O}$ or $\text{AlCl}_3 \cdot 6\text{H}_2\text{O}$ was tried and found to be very slow (24 h, at 25°C [24, 25]. The SPL fluorides (NaF, CaF_2 and Na_3AlF_6) were leached as fluoride precipitates and the NaF and Na_2CO_3 were removed from the SPL by water washing [26]. 76–86 mol% of the SPL refractory (Na_3AlF_6 and CaF_2) were extracted by using 0.34 M Al^{3+} solution at 25°C in 24 h.

After an initial water wash to leach NaF, followed by a single-leaching step using 0.5 M HNO_3 and 0.36 M $\text{Al}(\text{NO}_3)_3$ at 60°C [27], a total of 96.3% of the remaining fluoride was recovered along with 100% of the Mg and 90% of the Ca originally present in the SPL as MgF_2 and CaF_2 , respectively.

Bishoy [28] subjected the SPL to NaOH leaching first followed by HNO_3 leaching at various combinations of temperatures and liquid/solid ratios. The contribution of the alkali and acid concentrations on the leaching process was found to be 51.80% and 2.61%, respectively. The best combination (2.5 M NaOH, 5 M HNO_3 , 4.5-liter solution/kg SPL (or simply, L/S ratio), and 75°C) resulted in only 50.62% leaching of the SPL compounds.

Shi et al. [29] used a two-step alkaline-acidic leaching process to separate the cryolite from SPL and to purify the graphite carbon. Their results showed a recovery of 65.0% of soluble Na_3AlF_6 and Al_2O_3 compounds starting with NaOH leaching. However, they recovered 96.2% of the CaF_2 and $\text{NaAl}_{11}\text{O}_{17}$ compounds in the following HCl leaching step. By combining the acidic and alkaline leaching solutions, 95.6% of the cryolite precipitates (at pH = 9, T = 70°C , and time = 2 h) with a 96.4% purity.

Parhi & Rath [30] adopted a similar two-step leaching process to recover carbon and cryolite fractions from the SPL. They used HCl for leaching of CaF_2 and $\text{NaAl}_{11}\text{O}_{17}$ followed by NaOH for leaching of Na_3AlF_6 and Al_2O_3 . A maximum leaching efficiency of 86.01% was achieved at (10 M HCl, 1.5 M NaOH, 4.5 L/S ratio and 100°C). The carbon recovery increased from 42.19% to 76.85% after treatment.

Zhao (2012) [31] presented a leaching process using water and H_2SO_4 to recover HF from the SPL. The cake obtained contains graphite powder, aluminum hydroxide $\{\text{Al}(\text{OH})_3\}$ and alumina (Al_2O_3) while the filtrate contains fluorides and sulfates.

Cao et al. [32] recovered fluoride and carbon from the SPL by a water washing followed by leaching with aluminum sulfate $\{\text{Al}_2(\text{SO}_4)_3 \cdot 18\text{H}_2\text{O}\}$ solution at 25°C for 24 h. The carbon recovery achieved was 88%. $\text{Al}_2[(\text{OH})_{0.46}\text{F}_{0.54}] \cdot 6\text{H}_2\text{O}$ and $5\text{NaF} \cdot 3\text{AlF}_3$ precipitated at (90°C , pH 5.5, 3 h) with a maximum fluoride recovery of 99.7%. The main products after calcination were AlF_3 and $5\text{NaF} \cdot 3\text{AlF}_3$.

Li et al. [33] employed a two-step leaching process: (1) NaF is leached by water from the imbedded electrolyte, then (2) Na_3AlF_6 , CaF_2 and $\text{NaAl}_{11}\text{O}_{17}$ are leached using acidic anodizing wastewater (H_2SO_4 solution). Then the electrolyte components are precipitated from the mixed filtrates of steps (1) and (2). Most of the NaF in the SPL was dissolved in step (1); the residual electrolyte was mainly cryolite (with $\sim 0.95\%$ NaF). The purity of the carbon recovered was about 95.5% under

(80°C; L/S = 8 L/kg; 300 rpm; 3 h). The cryolite recovery from the mixed filtrate at (75°C; 4 h; pH 9; F/Al ratio of 6:1) was 98.4% while the Na₂SO₄ crystals purity was 92.0%.

The solubility of aluminum hydroxyfluoride at 30–70°C and its precipitation from synthetic solutions was studied by [34]. Their results suggest that when NaOH is used for the pH adjustment, a high F:Al ratio as well as higher pH were problematic because of the competitive co-precipitation of sodium fluoroaluminates hydrates (NaAlO₂.xH₂O) [34, 35]. Further, high purity AlF₂OH·H₂O crystals were produced at F:Al ratio of 1.6 and pH of 4.9.

Ntuk et al. [34] used two methods of AlF₂OH crystallization: (1) partial neutralization-crystallization for the bulk AlF₂OH and (2) solution evaporation-crystallization for the beneficiation of the very small AlF₂OH particles (< 30 μm), i.e. those below the acceptable size.

A leachate solution containing (AlF₂⁺, Na₂SO₄) was mixed with a controlled amount of NaOH (pH 4.5–5.5) and fed to a crystallizer to selectively produce AlF₂OH·H₂O, which was then filtered and separated from the Na₂SO₄ solution. Around 76–86% of the fluoride was recovered from the SPL. It should also be noted that AlF₂OH can be easily converted to AlF₃ by its reaction with HF [19].

The main properties of potential leaching acids and the after leaching produced acids are listed in **Table 5**.

2.1 Solubility of SPL constituents in water

Water leaching is a process that can extract a substance by its dissolution in water. Some of the SPL constituents such as NaF, Na₂CO₃, NaCN, and NaAlO₂ are soluble in water but with varying degrees and their solubilities mostly increase with the increase of temperature. Other SPL constituents such as NaAlSiO₄, Na₃AlF₆, CaF₂, and C are insoluble in water even at high temperatures (say, 100°C). **Table 6** shows the SPL individual constituents' solubilities in water at 25 and 100°C.

The hydrolysis of some of the SPL individual constituents (namely, NaCN, NaF, NaAlO₂ and Na₂CO₃) is discussed below.

NaCN when mixed with water or come in contact with aquatic species, the results will be detrimental to the health of that species. When NaCN is hydrolyzed,

	Name	MW, kg/kmol	Boiling point, °C	Density @ 25°C, kg/m ³
Leaching Acid				
HCl(g)	Hydrochloric	36.5	–85.1	1.49
35–37 wt% HCl		—	—	1200
100wt% HNO ₃	Nitric	63.0	83.0	1510
68 wt% HNO ₃		—	—	1410
100wt% HClO ₄	Perchloric	100.5	203.0	1768
70 wt% HClO ₄		—		1664
96–98 wt% H ₂ SO ₄	Sulfuric	98.1	337.0	1840
Produced Acid				
HCN(l)	Cyanic	27.0	25.6	687.6
HF(l)	Fluoric	20.1	19.5	990 ^a

^aSaturated liquid at 19.5°C.

Table 5.
 Some properties of mineral acids (sought for SPL leaching) and after-leaching produced acids.

Compound	Name	Solubility at 25°C, g/L	Solubility at 100°C, g/L
1. SPL main compounds:			
NaF	Sodium fluoride	41.5	50.5
Na ₂ CO ₃	Sodium carbonate	170	436
NaCN	Sodium cyanide	637	480
NaAlO ₂	Sodium aluminate	H. soluble	H. soluble
NaAlSiO ₄	Sodium aluminosilicate	Insoluble	Insoluble
Na ₃ AlF ₆	Cryolite	Insoluble	Insoluble
CaF ₂	Calcium fluoride	0.016	Insoluble
C	Graphite	Insoluble	Insoluble
2. Other SPL potential compounds:			
NaAlSi ₂ O ₆	Sodium aluminosilicate	Insoluble	Insoluble
Na ₄ Fe(CN) ₆	Sodium ferrocyanide(ia)	H. soluble	H. soluble
Na ₃ Fe(CN) ₆	Sodium ferricyanide(ia)	H. soluble	H. soluble
TiB ₂	Titanium diboride	Insoluble	Insoluble
Al ₂ O ₃	Aluminum oxide	Insoluble	Insoluble
LiF	Lithium fluoride	Insoluble	Insoluble
Li ₃ AlF ₆	Lithium aluminum hexafluoride	1.12 ^a	Very low
MgF ₂	Magnesium fluoride	Insoluble	Insoluble
TiB ₂	Titanium diboride	Insoluble	Insoluble
Fe ₂ O ₃	Ferric oxide	Insoluble	Insoluble

^aAt 20 °C. H. soluble = highly soluble.

Table 6.

Solubility of the SPL individual constituents in water at 25 and 100°C.

it will produce sodium formate and ammonia gas (for T > 50°C) [36] according to Eq. (1):

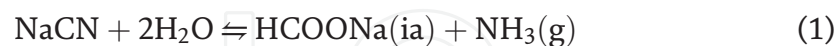

where (ia) refers to aqueous electrolyte (neutral) formed from undissociated aqueous species. However, the above reaction (Eq. 1) is very slow [37] although it is spontaneous ($\Delta G_R = -75.3$ kJ/mol at 30°C, see **Table 4**).

When NaCN is dissolved in excess water, hydrated sodium ion $[\text{Na}(\text{H}_2\text{O})_4]^+$ and a CN^- ion are produced. However, $[\text{Na}(\text{H}_2\text{O})_4]^+$ is a strong acid conjugate that will not react with water):

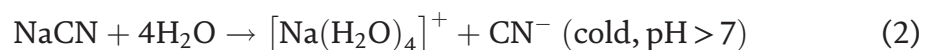

According to [36], it was stated that when NaCN is mixed with water at room temperature, it can undergo the reaction given by Eq. (3):



However, this reaction (Eq. 3) is non-spontaneous ($\Delta G_R = +59.6$ kJ/mol, see **Table A.5**) and is not possible at room temperature, but its reverse reaction is possible (spontaneous, $\Delta G_R = -59.6$ kJ/mol) and well known:



NaF dissolves in water to produce hydrated sodium $[\text{Na}(\text{H}_2\text{O})_4]^+$ ion and F^- ion:

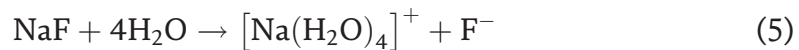

that further reacts with water to form HF(l) and OH^- ion (the strongest base):



NaAlO_2 is highly soluble in water and decomposes completely in highly alkaline solutions and turns to sodium tetra-hydroxy aluminate $\text{Na}[\text{Al}(\text{OH})_4]$ or its ionic forms ($\Delta G_{\text{R}} = -23.8$ kJ/mol, see **Table A.5**):

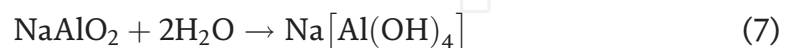

NaAlO_2 is claimed by some authors to react with water at high temperature and with time and produce NaOH and $\text{Al}(\text{OH})_3$ according to.

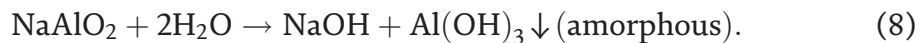

However, this claim is not true since the reaction is non-spontaneous ($\Delta G_{\text{R}} = +25.6$ kJ/mol, see **Table A.5**) and its spontaneity decreases with temperature (more $+\Delta G_{\text{R}}$) regardless of the retention time.

Na_2CO_3 is also highly soluble in water. The kinds of ions produced are as follows:

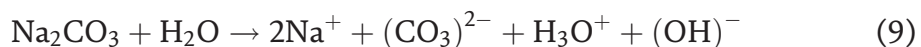

Again, the claim that Na_2CO_3 reacts with H_2O to produce NaOH and $\text{CO}_2(\text{g})$ is also not true because it is non-spontaneous reaction ($\Delta G_{\text{R}} = +131$ kJ/mol, see **Table A.5**).

On the other hand, **Table 7** shows the solubilities of the compounds produced after SPL acid leaching and/or during processing. These information are very helpful in devising the separation techniques of these products as discussed below in process description.

2.2 Process selection and the decision matrix

Bishoyi [28] made an extensive comparison to find out the best suitable leaching acid among H_2SO_4 , HCl, HNO_3 , and perchloric acid (HClO_4) while fixing the L/S ratio and observed that H_2SO_4 gave maximum leaching efficiency at 25°C . But as the temperature is increased from 25–100 $^\circ\text{C}$, all of these acids gave rise to almost the same leaching percentage. However, all of the acids undergo complete ionization in water.

The order of decreasing strength of the four acids under investigation is as follows: HClO_4 (strongest), HCl, H_2SO_4 , and HNO_3 (weakest). At 25°C , the dissociation constant (pK_a) of HClO_4 , HCl, H_2SO_4 , and HNO_3 are -8, -6.3, -3 ($\text{pK}_{a,1}$), and -1.4, respectively [38]. The larger the pK_a of an acid, the smaller its extent to dissociate at a given pH (i.e. the weaker the acid). Strong acids have pK_a values ≤ -2 . Note: $\text{pK}_a = \text{pH} - \log_{10}[\text{A}^-]/[\text{HA}]$, $[\text{HA}]$ and $[\text{A}^-]$ are the molar equilibrium concentrations (mol/L) of the acid and its anionic part, respectively.

On the other hand, the corrosivity of an acid depends on its level of dissociation, its concentration and phase. A vapor phase acid is more corrosive than a liquid

Compound	Name	Solubility at 25°C, g/L	Solubility at 100°C, g/L
(1) Intermediate products			
Al ₂ (SO ₄) ₃	Aluminum sulfate	H. soluble	H. soluble
Al(OH) ₃	Aluminum hydroxide	0.001	Insoluble
SiO ₂	Silica	Insoluble	Insoluble
CaSO ₄	Gypsum	Insoluble	Insoluble
(2) Final products			
C	Graphite	Insoluble	Insoluble
Na ₂ SiO ₃	Sodium silicate	H. soluble	H. soluble
Ca(ClO ₄) ₂	Calcium perchlorate	H. soluble	H. soluble
AlF _x (OH) _(3-x) , (x = 1 or 2)	Aluminum hydroxyfluoride	Soluble	Less soluble
AlF ₃	Aluminum fluoride	7.3	17.2
Na ₂ SO ₄	Sodium sulfate	H. soluble	H. soluble
(3) other products			
HF	Hydrogen fluoride	H. soluble	H. soluble
KF	Potassium fluoride	H. soluble	H. soluble
HCN	Hydrogen cyanide	H. soluble	H. soluble
AgCN	Silver cyanide	Insoluble	Insoluble
CO ₂	Carbon dioxide	Insoluble	Insoluble

Table 7.
Solubility of the after-leaching SPL products at 25 and 100°C.

Parameter	H ₂ SO ₄	HNO ₃	HCl	HClO ₄
Reactions spontaneity. See Tables A.1 to A.4 in Appendix A	All -ve	All -ve	5 -ve 2 +ve	5 -ve 2 +ve
Acid molarity (M) [31, 32]	5	5	10	7.5
pK _a or degree of corrosivity at 25 °C [38]	-3.0	-1.4	-6.3	-8.0
Acid cost, \$/kg (2019 prices)	0.2-0.35	0.2-0.25	0.15-0.35	4.0-4.5
L/S ratio [31, 32]	2.5	4.5	4.5	4.5
Optimum temp., °C [31, 32]	50	75	100	100

Table 8.
Values of the decision parameters sought for various leachant acids.

phase acid. In addition, the corrosivity of an acid increases as temperature is increased. **Table 8** shows the values of the parameters used in process selection among the four leachant acids mentioned above.

Table 9 shows the factors affecting process selection (decision matrix), factors weight and fraction among the sought leachant acids. In **Table 9**, F_i = Factor weight/ Σ factor weights. Overall score = $\Sigma F_i \times \text{Score}_i$. Based on that, the overall score in decreasing order is as follows: H₂SO₄ (highest), HNO₃, HCl, and HClO₄ (lowest).

In this work, we have calculated the change in the heat of reaction (ΔH_R) and the change in the Gibbs free energy of reaction (ΔG_R) for the reactions of the

Factor	Factor weight	F _i	Acid Individual Score, Score _i			
			H ₂ SO ₄	HNO ₃	HCl	HClO ₄
Spontaneity	20	0.22	100	100	70	80
Acid molarity	10	0.11	80	80	50	50
Degree of corrosivity	10	0.11	50	60	30	20
Acid cost	10	0.11	75	80	90	40
L/S ratio	20	0.22	70	50	70	50
Optimum temperature	20	0.22	80	50	25	25
Overall Score =	90	1.00	78.3	68.9	55.6	46.7

Table 9.
 Decision matrix: Factor, factor weight, fraction (F_i), individual and overall scores sought for the leaching acids.

individual constituents of the SPL waste. **Table A.1** to **A.4** in Appendix A show the calculated ΔH_R and ΔG_R at 30°C for the reactions with H₂SO₄, HNO₃, HCl, and HClO₄, respectively. Inspection of these values shows that most of these reactions are exothermic ($-\Delta H_R$) and spontaneous ($-\Delta G_R$). We have also calculated ΔH_R and ΔG_R for all other potential reactions of the SPL constituents with H₂SO₄ (see **Table A.5**) as well as for the reactions with H₂SO₄ of potential trace materials that might present in the SPL (see **Table A.6**).

The operating conditions for these acids are as follows: H₂SO₄ liquid at room temperature, liquid HNO₃, HCl gas, and HClO₄ gas. The commercial grades of these acids are usually available at 98 wt% H₂SO₄, 68 wt% HNO₃ (pH = 1.2), 34–36 wt% HCl (pH = 1.1), and 70 wt% HClO₄. Because of this, the higher the concentration of the acid available for use, the lower the molarity is required for leaching. However, in all cases, an alkali leachant (e.g. NaOH) needs to be used either before or after the acid leaching step. But in this work, we have decided to add NaOH after the acid leaching step.

All of these leaching acids produce the same acid gases (namely, HCN, HF and CO₂), SiO₂ along with the existing graphite carbon. However, H₂SO₄ produces insoluble gypsum (CaSO₄) and soluble sodium sulfate (Na₂SO₄) along with other soluble salts that need to be crystallized and separated (i.e. AlF₂OH and/or AlF₃). However, the other leaching acids produce two soluble salts along with AlF₂OH and/or AlF₃ that makes separation more difficult. **Table 10** shows the generated intermediate and final products when H₂SO₄, HNO₃, HCl, or HClO₄, are used as the leaching acids. Based on that, the H₂SO₄ as a leachant seems to have more advantages above the other leaching acids, among which is the production of Na₂SO₄; one of the most profitable sodium salts. Thus, in the next discussion we will concentrate on leaching the SPL constituents by H₂SO₄ solution.

Product	Leaching Acid			
	H ₂ SO ₄	HNO ₃	HCl(g)	HClO ₄ (g)
Intermediate	Al ₂ (SO ₄) ₃	Al(NO ₃) ₃ (ia)	AlCl ₃	Al(ClO ₄) ₃ (ia)
Soluble or aqueous	AlF ₂ OH, AlF ₃ , Na ₂ SO ₄	AlF ₂ OH, AlF ₃ , NaNO ₃ , Ca(NO ₃) ₂	AlF ₂ OH, AlF ₃ , NaCl, CaCl ₂	AlF ₂ OH, AlF ₃ , NaClO ₄ , Ca(ClO ₄) ₂
Insoluble	C, SiO ₂ , CaSO ₄	C, SiO ₂	C, SiO ₂	C, SiO ₂
Gas	CO ₂ , HF, HCN	CO ₂ , HF, HCN	CO ₂ , HF, HCN	CO ₂ , HF, HCN

Table 10.
 Products resulting from SPL treatment as a function of leachant acid.

Lastly, it should be noted that the aluminum salts $\text{Al}_2(\text{SO}_4)_3$, $\text{Al}(\text{NO}_3)_3$, AlCl_3 , and $\text{Al}(\text{ClO}_4)_3$ behave as acidic or basic solutions in water. For example, in $\text{Al}_2(\text{SO}_4)_3$, the SO_4^{2-} anion is neutral while the Al^{3+} is not. In the reaction:

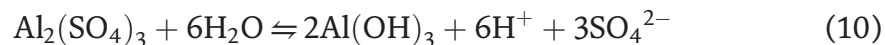

the produced H_2SO_4 , which is a strong acid, dissociates in the aqueous phase to form 2H^+ and SO_4^{2-} ions, and as a result, the solution is considered acidic. For this reason, any of the above-mentioned aluminum salts, if present in the aqueous solution, can behave as acidic leachants for some of the SPL constituents (such as Na_3AlF_6 and CaF_2). This conclusion is used here as a basis for the selection of the SPL acid leaching process.

3. Leaching of the SPL individual constituents by H_2SO_4 solution

The leaching process starts with the dissolution of the water-soluble compounds of the SPL (namely, NaF , NaCN , Na_2CO_3 , and NaAlO_2) in the H_2SO_4 solution rather than leaching in water followed by the acid. However, leaching of these four compounds in water is possible but it is very slow and requires large vessels.

Leaching reactions of the above-mentioned water-soluble compounds with H_2SO_4 are presented by Eqs. (11) to (14). See reactions R1 to R4 in **Table A.1**.

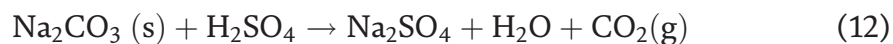
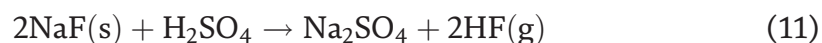

On the other hand, the graphite present in SPL is the only compound that does not react with acids (e.g. H_2SO_4), alkalis (e.g. NaOH) or acidic Al^{3+} solution. However, the reactions of the three other insoluble compounds present in the SPL (namely, NaAlSiO_4 , Na_3AlF_6 , and CaF_2) are explained below.

1. The NaAlSiO_4 dissolves in aqueous H_2SO_4 solution and produces the intermediate product $\text{NaAl}_3(\text{SO}_4)_2(\text{OH})_6$ according to Eq. (15)



$\text{NaAl}_3(\text{SO}_4)_2(\text{OH})_6$ dissolves in excess H_2SO_4 [39] according to Eq. (16).



By multiplying Eq. (10) by 2, adding it to Eq. (15), and dividing the result by 3 gives the net result presented by Eq. (17) (similar to that reported by [40]):

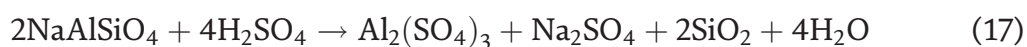

2. The cryolite (Na_3AlF_6) does not react with H_2SO_4 spontaneously; it has a high $+\Delta G_{\text{R}}$. However, it reacts spontaneously with concentrated NaOH solution to produce NaF and the intermediate product $\text{NaAl}(\text{OH})_4$ according to Eq. (18):

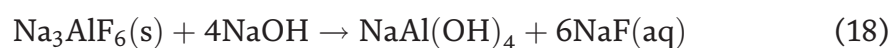

However, both resulting products (NaF and NaAl(OH)₄) need to be leached with or neutralized by H₂SO₄ according to Eq. (11) (for NaF) and according to Eq. (19) for NaAl(OH)₄:



An alternative to this two-step leaching process expressed by Eqs. (16) and (18), the Na₃AlF₆ can be leached with an acidic Al³⁺ solution comprised of Al(OH)₃ and H₂SO₄, which was found to be more effective than leaching with an acid only or an alkali only [41, 19]. This acidic Al³⁺ solution can be prepared according to Eq. (20):



and the reaction of Na₃AlF₆ with the above solution gives

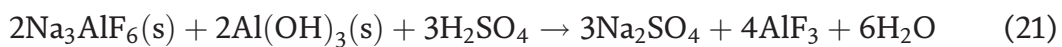

However, the Al₂(SO₄)₃ (or acidic Al³⁺) solution is already produced by Eqs. (14) and (17) presented above. Here, the Al₂(SO₄)₃ has an *amphoteric* character, i.e. it can both act as an acidic and a basic solution in the aqueous phase. Thus, the Na₃AlF₆ reacts (spontaneously) with the present acidic Al₂(SO₄)₃ solution to give Na₂SO₄ and AlF₃ according to Eq. (22):

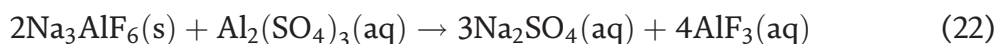

3. The reaction of CaF₂ with H₂SO₄ is less spontaneous (very small -ΔG_R that decreases with temperature) and gives CaSO₄ and HF according to Eq. (23), (which is not required at this stage of leaching):

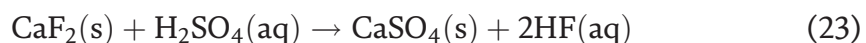

However, CaF₂ can react (spontaneously) with the solution presented by Eq. (19) according to Eq. (24).



But again, CaF₂ can also react (spontaneously) with the acidic Al₂(SO₄)₃ produced by Eqs. (14) and (17) to give CaSO₄ precipitate and aqueous AlF₃:



4. Process description

In this work, we propose a process for leaching of the main constituents of the SPL waste by H₂SO₄ solution. The combination of **Figures 1, 2 and 3** constitute the process flow diagram (PFD) of the proposed leaching process. Note: The numbers in red color beside the stream numbers on these figures, are the stream input temperature (30°C) or the calculated temperature using heat of mixing and reaction thermochemical data along with the energy balance equations. Most of the acid leaching reactions are exothermic (-ΔH_R) except those appearing in bold numbers in the ΔH_R column of **Table A.1** in particular.

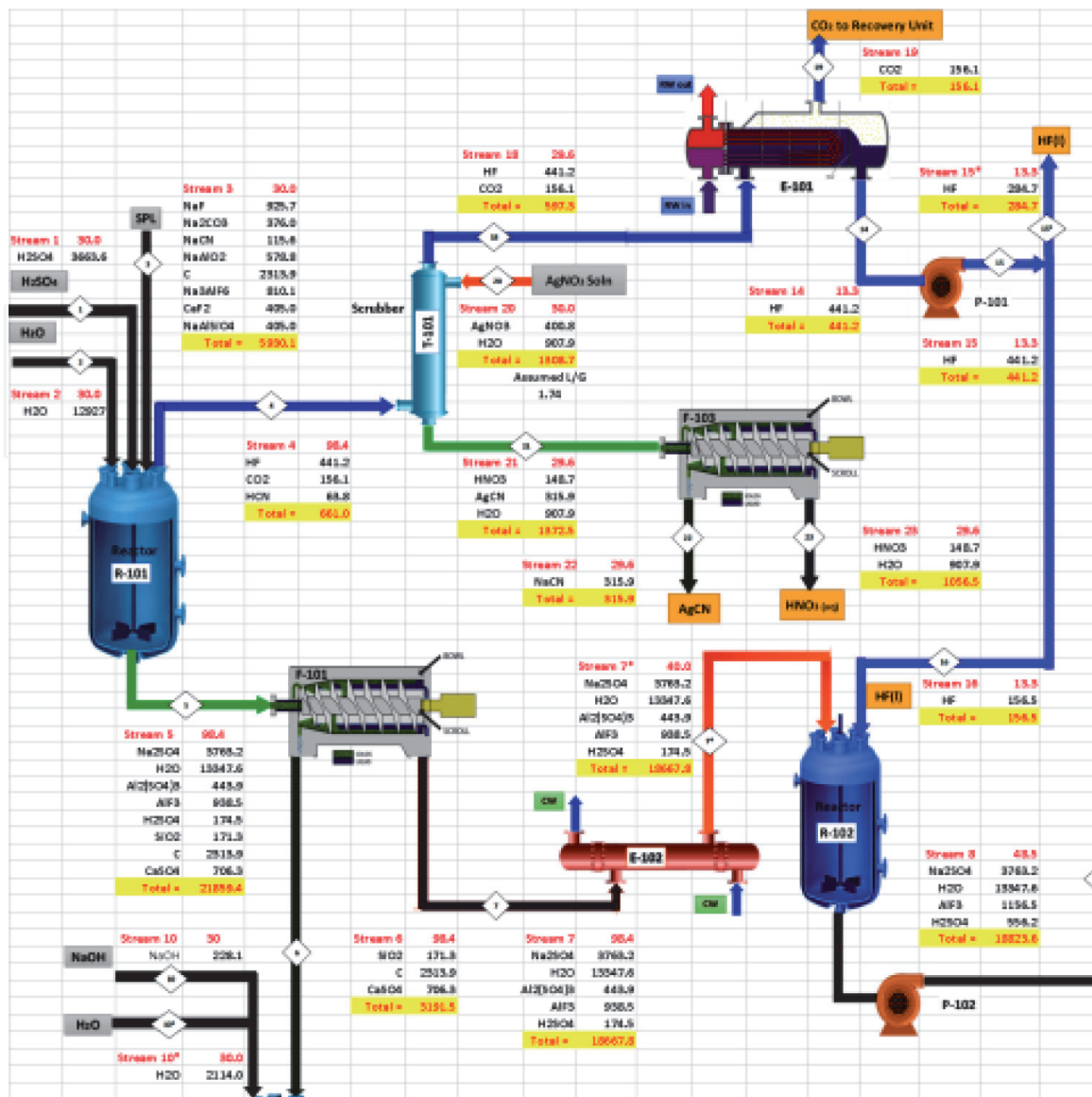

Figure 1. Process flow diagram and material balance for the SPL treatment.

The collected SPL waste first passes through crushing and grinding steps. The resulting SPL fines are fed to an agitated semi-batch reactor filled with a pre-prepared H_2SO_4 solution. To ensure that all the SPL particles are sufficiently exposed to the solution, a 2.5 M H_2SO_4 (with 5 wt% excess) is used along with a recommended L/S ratio of 2.52 liters of H_2SO_4 acid solution per kg of SPL [19]. The reactor contents should be kept under agitation for 2–4 h. A 40,000 tons of SPL is assumed to be processed annually (or 5930 kg/h based on a stream factor of 0.77). However, a total of 220 working days per year (batch-wise operation, 22 working days per month, and allowing 2 months for shutdown and maintenance, i.e. stream factor = 0.6) is suggested elsewhere [19].

Considering the composition ranges of the SPL main constituents reported in [12] and presented in Table 2, the composition, the mass and molar flow rates based on the SPL upper composition limit are given in Table 11.

The products generated during processing are classified into three categories or streams: (1) gaseous stream (HCN , HF and CO_2), (2) insoluble products stream (graphite, gypsum and SiO_2), and (3) soluble products stream (aluminum fluorides and sodium salts, mainly, Na_2SO_4). Details on processing of each of these streams are given below and demonstrated in Figures 1, 2 and 3 generated by the authors.

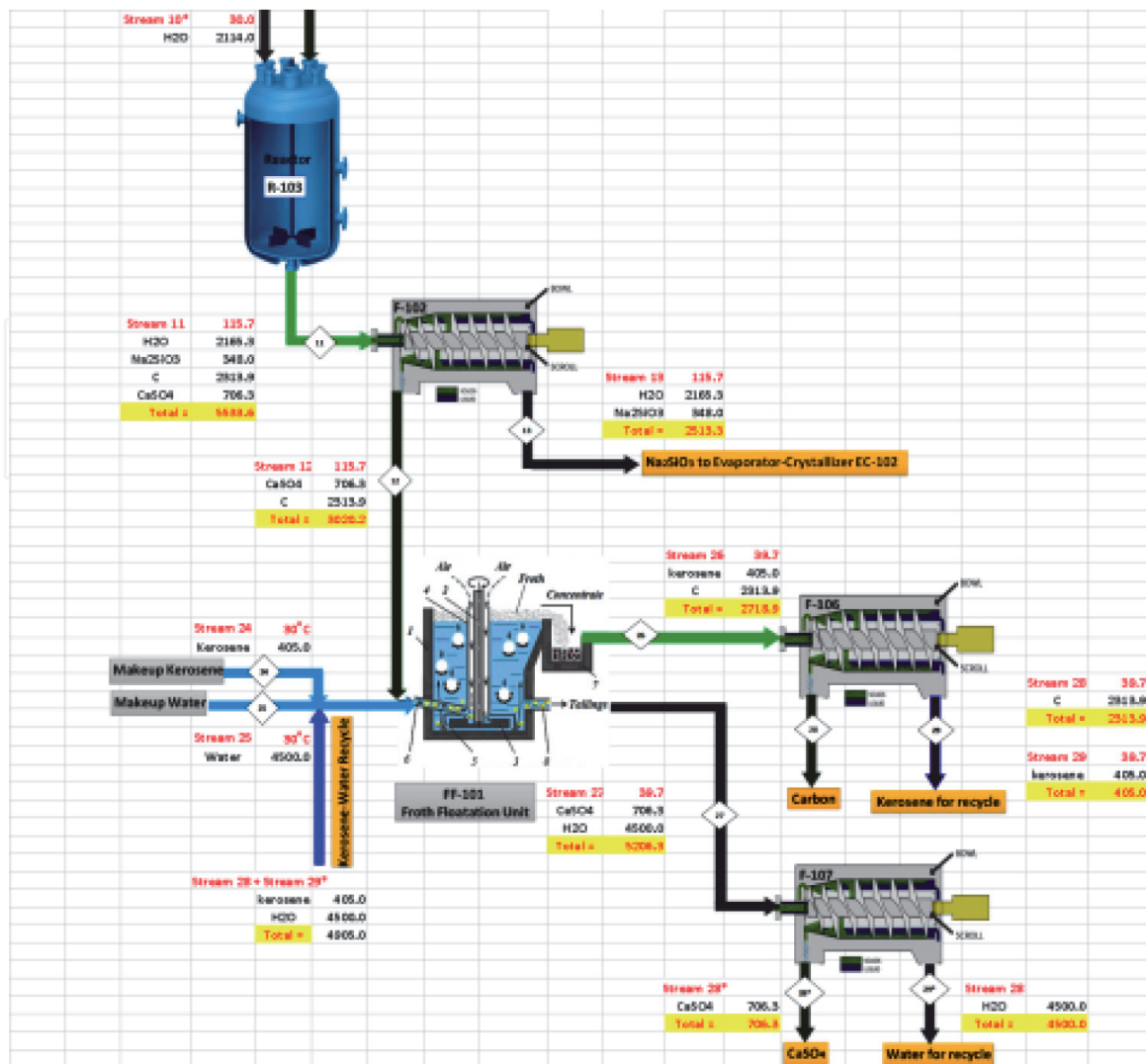

Figure 2.
 Process flow diagram and material balance for the SPL treatment ... continued.

1. During the leaching step, a gas stream (mainly, HCN, HF and CO₂) leaves reactor R-101, cooled (not shown on the PFD) and then sent to a gas emission-control scrubber (T-101) where the HCN gas is scrubbed by its reaction with a silver nitrate (AgNO₃) solution sprayed at the top. See **Figure 1**. This reaction is spontaneous and exothermic. As a result, silver cyanide (AgCN) is produced according to Eq. (26). See reaction R8 in **Table A.1**.



The AgCN is insoluble in water, but it is slightly soluble in aqueous HNO₃. The AgCN, is separated from the aqueous solution via filter F-103. The AgCN salt is stable at ambient conditions and is very valuable in gold extraction. However, it is highly toxic by ingestion and its contact with skin and eyes can cause severe irritation. It has a LD₅₀ oral (rat) of 123 mg/kg.

Note: It should be mentioned that no reaction will take place between aqueous AgNO₃ used in Eq. (26) and HF(l), HF(g) or CO₂, since these reactions are non-spontaneous at temperatures ≤90°C.

The HF can be recovered as a liquid from the HF-CO₂ gas mixture by cooling/condensation in E-101 to below its condensation temperature (at its partial pressure in the gas stream). The remaining gas from E-101 is sent to a CO₂

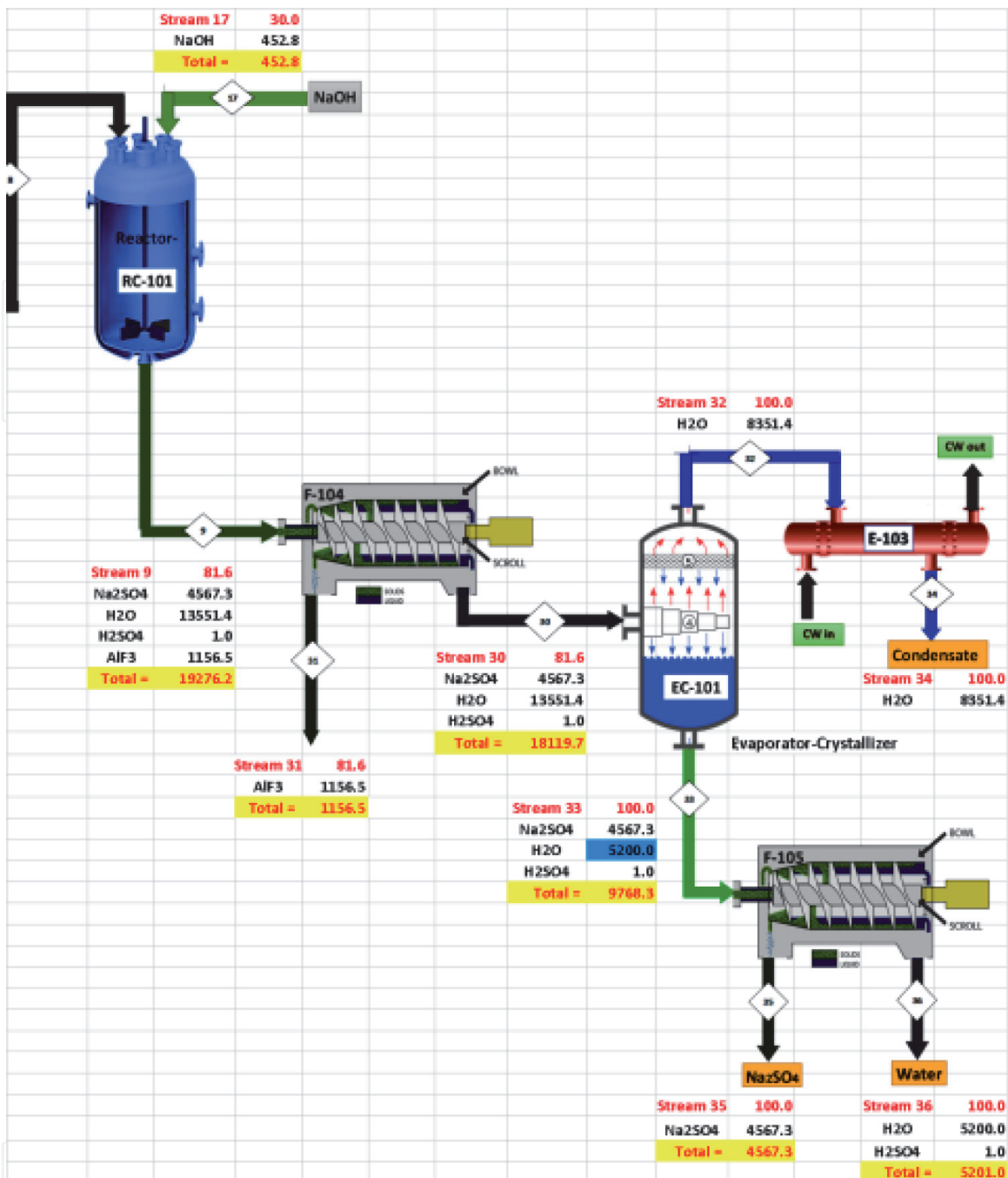

Figure 3. Process flow diagram and material balance for the SPL treatment ... concluded.

recovery unit. The recovered HF liquid is pumped (P-101) where part of it is used within the process to ensure that all the remaining aluminum sulfate is converted to AlF_3 (as explained below). The remaining part of the HF liquid can be sold as is or converted to potassium fluoride (KF); an important source of fluoride in many industries.

On the other hand, the normal boiling points of HF and HCN are $25.6^\circ C$ and $19.5^\circ C$, respectively. Thus, one much better option (and much cheaper than scrubbing by $AgNO_3$ solution) is the condensation of the HF gas followed by the condensation of HCN gas at their partial pressures in the gas phase stream leaving reactor R-101. This option avoids using the very expensive $AgNO_3$ salt, but in this case, the condensed HCN must be destroyed by direct oxidation or it can be converted to a stable $NaCN$ (soluble) salt by reacting HCN liquid with $NaNO_3$ (very cheap). But still a reactor and a separator are

Compound	MW, kg/kmol	Concentration, wt%	Mass Flow rate, kg/h	Molar Flow rate, kmol/h
NaF	41.99	15.61	925.70	22.05
Na ₂ CO ₃	105.99	6.34	375.97	3.55
NaCN	49.01	1.95	115.64	2.36
NaAlO ₂	81.97	9.76	578.78	7.06
Na ₃ AlF ₆	209.94	13.66	810.06	3.86
NaAlSiO ₄	202.14	6.83	405.03	2.00
CaF ₂	78.07	6.83	405.03	5.19
C	12.00	39.02	2313.94	192.83
Total =		100.00	5930.14	238.89

Table 11.
 Normalized composition of the SPL main constituents used in this work.

needed. In either case, the resulting gas stream needs to be sent to the CO₂ recovery unit.

2. After completion of the leaching step, the slurry mixture is sent to filter F-101 where the insoluble solids (SiO₂, graphite and gypsum) are separated from the aqueous solution containing soluble intermediate and final products (Na₂SO₄, AlF₃ (and/or AlF₂OH), remaining Al₂(SO₄)₃, unreacted H₂SO₄, and water).

The insoluble solids stream is sent to reactor R-103 where the SiO₂ is reacted with aqueous NaOH to produce soluble sodium silicate (Na₂SiO₃) according to reaction (27). See reaction R9 in **Table A.1**.



which is then separated from the graphite-gypsum solid mixture via filter F-102. See **Figure 2**. The Na₂SiO₃ in the aqueous solution can then be saturated by evaporation and precipitated as Na₂SiO₃ crystals (not shown on the PFD).

The graphite and gypsum can be then separated from each other in a froth flotation unit (FF-101) where an oil (e.g. 1–10 wt% kerosene) in water is used, along with air bubbling and slow agitation. See **Figure 3**. The recommended particle size for froth flotation lies between +25 and 75 μm [42]. The hydrophobic graphite along with kerosene floats up as a froth while the hydrophilic gypsum along with water settles to the bottom of the unit. The graphite-kerosene stream is sent to filter F-106 to recover the graphite and recycle the kerosene back to the froth flotation unit. Similarly, the gypsum-water stream is sent to filter F-107 to recover the gypsum and recycle the water back to the froth flotation unit.

It should be mentioned that we have experimentally separated the graphite carbon from gypsum (using a kerosene/water volumetric ratio = 0.1 along with air bubbling at room temperature).

3. The aqueous phase from filter F-101 is cooled in E-102 and then sent to reactor R-102, where the remaining Al₂(SO₄)₃ is converted to AlF₃ (and/or AlF₂OH) by its reaction with part of the recovered HF liquid, according to the relatively high spontaneous Eq. (28) ($\Delta G_R = -196.65$ kJ/mol). at 30°C. See reaction R10 in **Table A.1**.



Due to the presence of fluoride ions in R-102, the dominant crystal species will be AlF_3 . However, the reaction between Na_2SO_4 and $\text{HF}(\text{l})$ is much less competent than Eq. (28) since it is much less spontaneous ($\Delta G_{\text{R}} = -32.7 \text{ kJ/mol}$). See reaction R1 in **Table A.1**.

In order to recover the AlF_3 crystals, the contents of reactor R-102 are pumped through P-102 to the reactor-crystallizer RC-101, where the conditions required for AlF_3 crystallization have to be established. A controlled amount of NaOH has to be added to neutralize most of the remaining H_2SO_4 according to Eq. (29). See reaction R11 in **Table A.1**.

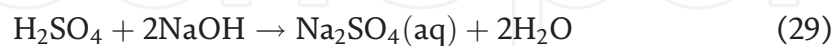

and at the same time to maintain the solution in RC-101 at a pH of 4.5–5.5; required to saturate and precipitate AlF_3 [19], noting that the solubility of AlF_2OH (and AlF_3) decreases with the increase of the pH.

Any AlF_2OH produced can be easily converted to AlF_3 by its reaction with some of the HF liquid recovered earlier, according to the spontaneous presented by Eq. (30). See reaction R12 in **Table A.1**.

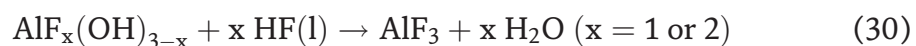

or,



and

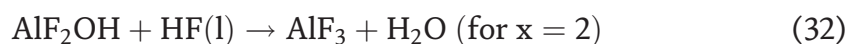

Thus, the reaction presented by Eq. (30) can be carried out before the addition of the NaOH solution.

The crystals produced in the reactor-crystallizer RC-101 are separated via filter F-104 as AlF_3 cake. To remove the impurities from the AlF_3 , the stream needs to be washed with fresh water. The AlF_3 is then dried, cooled and stored.

The filtrate leaving filter F-104 is sent to the evaporator-crystallizer EC-101, where the Na_2SO_4 solution is saturated by flash evaporation under vacuum and Na_2SO_4 is crystallized and separated via filter F-105. See **Figure 3**. The Na_2SO_4 crystals can be further dehydrated and dried before being stored.

Lastly, the water vapor leaving EC-101 is condensed in E-103 and collected for reuse within the process, along with other recovered water from the various streams of the above described process.

5. Preliminary economic analysis

A preliminary economic analysis has been made on the above proposed process (assuming a theoretical 100% conversion and/or recovery) following the guidelines of ref. [43]. The amounts and costs of raw materials used as well as the amounts and

market prices of the materials produced are listed in **Table 12**. The annual cost or price of a given material = amount (kg/h) x unit cost or price (\$/kg) x 6475.2 (h/year). The 6475.2 factor comes from 0.77 x 24 x 365. We made a preliminary design for the process equipment and estimated the fixed capital cost of the plant excluding land, FCI_L , to be 27.32 M\$.

The number of operators per job was estimated based on Eq. (33):

$$N_{OL} = (6.29 + 31.7 P^2 + 0.23 * N_{np})^{0.5} \quad (33)$$

where P stand for particulate (solid) and N_{np} for non-particulate (fluid) handling equipment ($P = 1$ for FF-101, $N_{np} = 15$). The total number of operators required over the year = 4.47 N_{OL} . The salary per operator was assumed to be \$49000.

The FCI_L along with the estimated annual costs of labor C_{OL} , raw materials C_{RM} , utilities C_{UT} , and waste treatment C_{WT} (given in **Table 13**) were used to calculate the cost of manufacturing excluding depreciation, COM_d , according to Eq. (34):

$$COM_d = 0.18 FCI_L + 2.73 C_{OL} + 1.23 (C_{RM} + C_{UT} + C_{WT}) \quad (34)$$

The calculated $COM_d = 21.73$ M\$/year.

Now, assuming priceless produced HNO_3 , Na_2SiO_3 , CO_2 and output water, the income from main sales (revenue, R) was found to be 38.09 M\$/year. Also, since $AgNO_3$ and $AgCN$ are very expensive and sharply affect the profitability of the process, this option has been excluded in the economic analysis.

Raw Materials	Amount, kg/h	Value, \$/kg	Products	Amount, kg/h	Value, \$/kg
SPL	5930.1	0.12 ^a	AlF ₃	1156.5	1.6
H ₂ SO ₄	3663.8	0.086	HF	284.7	0.9
NaOH	686.9	0.692	Graphite C	2213.9	0.9
			Na ₂ SO ₄	4567.3	0.27
			CaSO ₄	706.3	0.4
			HNO ₃	134.0	0.243
			Na ₂ SiO ₃	348.0	0.811
			CO ₂	156.1	0.0
Input water	15041	6.7x10 ⁻⁵	Output water	15716.7	6.7x10 ⁻⁵

^aEstimated cost for crushing, grinding and handling of the SPL.

Table 12.
 Amounts of raw materials and products and their average prices [44].

Cost Item	M\$/year
Operating labor cost, C_{OL}	1.421
Raw materials cost, C_{RM}	10.14
Utilities cost, C_{UT}	0.38
Waste treatment cost, C_{WT}	0.0
Cost of manufacturing excluding depreciation, COM_d	21.73

Table 13.
 Estimated individual operating costs and COM_d .

Item	Value	Units
FCI_L	27.32	M\$
Land cost, $L = 0.1 FCI_L$	2.732	M\$
Working capital, $WC = 0.2 FCI_L$	5.464	M\$
Salvage value, $S = 0.1 FCI_L$	2.732	M\$
Construction period	2	years
Project life, n	10	years
Depreciation period, n_d	5	years
Depreciation, $d = FCI_L/n_d$	5.464	M\$/year
Tax rate, t	20	%
Interest rate, i	10	%

Table 14.
Input data for discounted cumulative cash flow analysis.

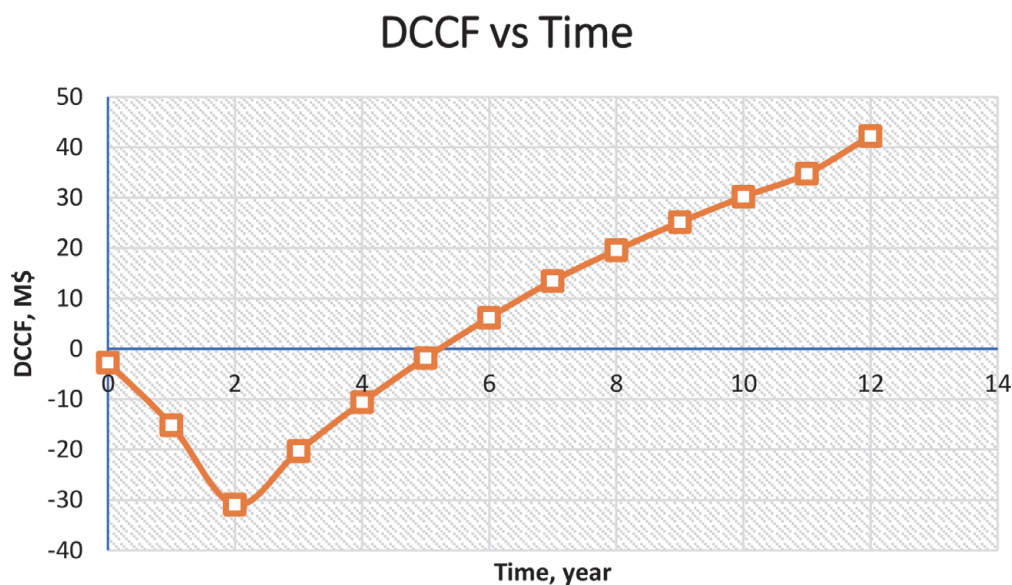

Figure 4.
Discounted cumulative cash flow diagram. (DCCF) for the above studied process.

The input data used for generating the cumulative cash flow analysis are presented in **Table 14**. The discounted cumulative cash flow diagram for the above process analysis is shown in **Figure 4**. Following [43] economic analyses and using the data presented above, and assuming an interest rate of 10%, a tax rate of 20%, the calculated net present value, $NPV = 42.24$ M\$, the discounted payback period, $DPBP = 2.38$ years, and the discounted cash flow rate of return, $DCFROR = 31.73\%$.

6. Conclusions

In this work an environmentally friendly process to recover the valuable elements contained in the SPL is presented and deeply analyzed. The decision to use H_2SO_4 as a leachant was justified through deep analysis. The proposed process along with the process flow diagram and complete material balance results have been explained and included.

The recovered materials include graphite carbon, aluminum fluoride (AlF₃), sodium sulfate (Na₂SO₄), and others when H₂SO₄ is used as the leaching agent. The level of emission of the hazardous gases such as HCN and HF are minimized. The recovered HF liquid is partially used within the process. The remaining HF can be used in production of potassium fluoride (KF). Also, CO₂ gas can also be recovered from the process gas streams.

The economic analyses indicate that the process will be profitable under the conditions stated in this work. The process net present value, NPV = 42.24 M\$, the discounted payback period, DPBP = 2.38 years, and the discounted cash flow rate of return, DCFROR = 31.73%.

Acknowledgements

The authors are grateful for the United Arab Emirates University (Office of the Deputy Vice Chancellor for Research & Graduate Studies) who funded this work under Fund number G00003084, 2019/2020.

Appendix A

Note that reactions R8, R8*, R9, and R12 presented in **Table A.1** (for H₂SO₄) are common in all acid-leaching processes using HNO₃ (**Table A.2**), HCl (**Table A.3**), and HClO₄ (**Table A.4**)

#	Reaction	ΔH _R , kJ/mol	ΔG _R , kJ/mol
R1	2NaF + H ₂ SO ₄ → Na ₂ SO ₄ + 2HF(l)	-20.3	-32.7
R1 ^a	2NaF + H ₂ SO ₄ → Na ₂ SO ₄ + 2HF(g)	32.5	-39.4
R2	Na ₂ CO ₃ + H ₂ SO ₄ → Na ₂ SO ₄ + H ₂ O + CO ₂ (g)	-122.6	-164.3
R3	2NaCN + H ₂ SO ₄ → Na ₂ SO ₄ + 2HCN(l)	-181.8	-176.1
R3 ^a	2NaCN + H ₂ SO ₄ → Na ₂ SO ₄ + 2HCN(g)	-122.6	-170.5
R4	2NaAlO ₂ + 4H ₂ SO ₄ → Al ₂ (SO ₄) ₃ + Na ₂ SO ₄ + 4H ₂ O	-450.0	-419.7
R5	2NaAlSiO ₄ + 4H ₂ SO ₄ → Al ₂ (SO ₄) ₃ + Na ₂ SO ₄ + 2SiO ₂ + 4H ₂ O	-348.7	-310.8
R6	2Na ₃ AlF ₆ + Al ₂ (SO ₄) ₃ → 3Na ₂ SO ₄ + 4AlF ₃	-119.9	-119.5
R7	3CaF ₂ + Al ₂ (SO ₄) ₃ → 3CaSO ₄ + 2AlF ₃	-209.1	-211.6
R8	HCN(l) + AgNO ₃ → AgCN + HNO ₃	-13.0	-15.8
R8 ^a	HCN(g) + AgNO ₃ → AgCN + HNO ₃	-10.2	-4.4
R9	SiO ₂ + 2NaOH → Na ₂ SiO ₃ + H ₂ O	-84.7	-88.9
R10	Al ₂ (SO ₄) ₃ + 6HF(l) → 2AlF ₃ + 3H ₂ SO ₄	-223.3	-196.7
R11	H ₂ SO ₄ + 2NaOH → Na ₂ SO ₄ + 2H ₂ O	-294.1	295.3
R12-a	Al(OH) ₂ F(g) + 2HF(l) → AlF ₃ + 2H ₂ O	-155.6	-140.7
R12-b	Al(OH)F ₂ (g) + HF(l) → AlF ₃ + H ₂ O	-140.7	-106.1

^aStands for reactions involving HF(g) or HCN(g).

Table A.1.

Calculated ΔH_R and ΔG_R at 30°C for the reactions of the main SPL constituents when leached with H₂SO₄ solution.

#	Reaction	ΔH_R , kJ/mol	ΔG_R , kJ/mol
R1	$\text{NaF} + \text{HNO}_3(\text{l}) \rightarrow \text{NaNO}_3 + \text{HF}(\text{l})$	-16.8	-12.2
R1 ^a	$\text{NaF} + \text{HNO}_3(\text{l}) \rightarrow \text{NaNO}_3 + \text{HF}(\text{g})$	9.6	-15.5
R2	$\text{Na}_2\text{CO}_3 + 2\text{HNO}_3(\text{l}) \rightarrow 2\text{NaNO}_3 + \text{H}_2\text{O} + \text{CO}_2(\text{g})$	-135.9	-155.9
R3	$\text{NaCN} + \text{HNO}_3(\text{l}) \rightarrow \text{NaNO}_3 + \text{HCN}(\text{l})$	-97.6	-83.9
R3 ^a	$\text{NaCN} + \text{HNO}_3(\text{l}) \rightarrow \text{NaNO}_3 + \text{HCN}(\text{g})$	-68.0	-81.1
R4	$\text{NaAlO}_2 + 4\text{HNO}_3(\text{l}) \rightarrow \text{NaNO}_3 + \text{Al}(\text{NO}_3)_3(\text{ia}) + 2\text{H}_2\text{O}$	-367.4	-268.2
R5	$\text{NaAlSiO}_4 + 4\text{HNO}_3(\text{l}) \rightarrow \text{SiO}_2 + \text{Al}(\text{NO}_3)_3(\text{ia}) + \text{NaNO}_3 + 2\text{H}_2\text{O}$	-316.8	-213.8
R6-a	$\text{Na}_3\text{AlF}_6 + \text{Al}(\text{NO}_3)_3(\text{ia}) \rightarrow 3\text{NaNO}_3 + 2\text{AlF}_3$	55.8	15.3
R6-b	$\text{Na}_3\text{AlF}_6 + \text{Al}(\text{NO}_3)_3 \cdot 6\text{H}_2\text{O} \rightarrow 3\text{NaNO}_3 + 2\text{AlF}_3 + 6\text{H}_2\text{O}$	32.5	-28.05 ^c
R6 ^b	$\text{Na}_3\text{AlF}_6 + 3\text{HNO}_3(\text{l}) + \text{Al}(\text{OH})_3 \rightarrow 3\text{NaNO}_3 + 2\text{AlF}_3 + 3\text{H}_2\text{O}$	-160.5	-135.0
R7	$1.5\text{CaF}_2 + \text{Al}(\text{NO}_3)_3(\text{ia}) \rightarrow 1.5\text{Ca}(\text{NO}_3)_2 + \text{AlF}_3$	83.6	40.3
R7 ^b	$1.5\text{CaF}_2 + \text{Al}(\text{OH})_3 + 3\text{HNO}_3(\text{l}) \rightarrow 1.5\text{Ca}(\text{NO}_3)_2 + \text{AlF}_3 + 3\text{H}_2\text{O}$	-132.6	-110.03 ^d
R10	$\text{Al}(\text{NO}_3)_3(\text{ia}) + 3\text{HF}(\text{l}) \rightarrow \text{AlF}_3 + 3\text{HNO}_3$	24.0	-35.9
R11	$\text{HNO}_3 + \text{NaOH} \rightarrow \text{NaNO}_3 + \text{H}_2\text{O}$	-153.6	-143.4

^aStands for reactions involving HF(g) or HCN(g).

^bStands for alternative spontaneous reaction.

^c ΔG_R at $T > 100^\circ\text{C}$.

^d ΔG_R at $T > 180^\circ\text{C}$.

Table A.2.

SPL reactions with HNO_3 and their ΔH_R and ΔG_R at 30°C .

#	Reaction	ΔH_R , kJ/mol	ΔG_R , kJ/mol
R1	$\text{NaF} + \text{HCl}(\text{g}) \rightarrow \text{NaCl} + \text{HF}(\text{l})$	-41.9	-14.5
R1 ^a	$\text{NaF} + \text{HCl}(\text{g}) \rightarrow \text{NaCl} + \text{HF}(\text{g})$	-15.5	-17.9
R2	$\text{Na}_2\text{CO}_3 + 2\text{HCl}(\text{g}) \rightarrow 2\text{NaCl} + \text{H}_2\text{O} + \text{CO}_2(\text{g})$	-186.1	-160.7
R3	$\text{NaCN} + \text{HCl}(\text{g}) \rightarrow \text{NaCl} + \text{HCN}(\text{l})$	-122.6	-86.2
R3 ^a	$\text{NaCN} + \text{HCl}(\text{g}) \rightarrow \text{NaCl} + \text{HCN}(\text{g})$	-93.1	-83.5
R4	$\text{NaAlO}_2 + 4\text{HCl}(\text{g}) \rightarrow \text{NaCl} + \text{AlCl}_3 + 2\text{H}_2\text{O}$	-185.6	-35.4
R5	$\text{NaAlSiO}_4 + 4\text{HCl}(\text{g}) \rightarrow \text{SiO}_2 + \text{AlCl}_3 + \text{NaCl} + 2\text{H}_2\text{O}$	-134.9	19.0
R6	$\text{Na}_3\text{AlF}_6 + \text{AlCl}_3 \rightarrow 3\text{NaCl} + 2\text{AlF}_3$	-226.2	-226.7
R7	$3\text{CaF}_2 + 2\text{AlCl}_3 \rightarrow 3\text{CaCl}_2 + 2\text{AlF}_3$	-311.8	-322.1
R10	$\text{AlCl}_3 + 3\text{HF}(\text{l}) \rightarrow \text{AlF}_3 + 3\text{HCl}$	-432.3	-363.9
R11	$\text{HCl}(\text{a}) + \text{NaOH} \rightarrow \text{NaCl} + \text{H}_2\text{O}$	-95.5	-114.7

^aStands for reactions involving HF(g) or HCN(g).

Table A.3.

SPL reactions with $\text{HCl}(\text{g})$ and their ΔH_R and ΔG_R at 30°C .

#	Reaction	ΔH_R , kJ/mol	ΔG_R , kJ/mol
R1	$\text{NaF} + \text{HClO}_4(\text{g}) \rightarrow \text{NaClO}_4 + \text{HF}(\text{l})$	-111.0	-71.9
R1 ^a	$\text{NaF} + \text{HClO}_4(\text{g}) \rightarrow \text{NaClO}_4 + \text{HF}(\text{g})$	-84.6	-75.2
R1 ^c	$\text{NaF} + \text{HClO}_4(\text{ia}) \rightarrow \text{NaClO}_4 + \text{HF}(\text{g})$	50.4	24.8 ^d

#	Reaction	ΔH_R , kJ/mol	ΔG_R , kJ/mol
R2	$\text{Na}_2\text{CO}_3 + 2\text{HClO}_4(\text{g}) \rightarrow 2\text{NaClO}_4 + \text{H}_2\text{O}(\text{l}) + \text{CO}_2(\text{g})$	-324.4	-275.3
R3	$\text{NaCN} + \text{HClO}_4(\text{g}) \rightarrow \text{NaClO}_4 + \text{HCN}(\text{l})$	-191.8	-143.6
R3 ^a	$\text{NaCN} + \text{HClO}_4(\text{g}) \rightarrow \text{NaClO}_4 + \text{HCN}(\text{g})$	-162.1	-140.7
R4	$\text{NaAlO}_2 + 4\text{HClO}_4(\text{g}) \rightarrow \text{NaClO}_4 + \text{Al}(\text{ClO}_4)_3(\text{ia}) + 2\text{H}_2\text{O}$	-743.6	-523.7
R5	$\text{NaAlSiO}_4 + 4\text{HClO}_4(\text{g}) \rightarrow \text{SiO}_2 + \text{Al}(\text{ClO}_4)_3(\text{ia}) + \text{NaClO}_4 + 2\text{H}_2\text{O}$	-693.0	-469.3
R6	$\text{Na}_3\text{AlF}_6 + \text{Al}(\text{ClO}_4)_3(\text{ia}) \rightarrow 3\text{NaClO}_4 + 2\text{AlF}_3$	55.2	32.1 ^e
R6 ^b	$\text{Na}_3\text{AlF}_6 + 3\text{HClO}_4(\text{g}) + \text{Al}(\text{OH})_3 \rightarrow 3\text{NaClO}_4 + 2\text{AlF}_3 + 3\text{H}_2\text{O}$	-443.1	-314.1
R7	$1.5\text{CaF}_2 + \text{Al}(\text{ClO}_4)_3(\text{ia}) \rightarrow 1.5\text{Ca}(\text{ClO}_4)_2 + \text{AlF}_3$	141.7	32.1 ^f
R7 ^b	$1.5\text{CaF}_2 + \text{Al}(\text{OH})_3 + 3\text{HClO}_4(\text{g}) \rightarrow 1.5\text{Ca}(\text{ClO}_4)_2 + \text{AlF}_3 + 3\text{H}_2\text{O}$	-356.5	-224.9
R10	$\text{Al}(\text{ClO}_4)_3(\text{ia}) + 3\text{HF}(\text{l}) \rightarrow \text{AlF}_3 + 3\text{HClO}_4(\text{g})$	305.8	159.8 ^g
R10 ^a	$\text{Al}(\text{OH})_3 + 3\text{HClO}_4(\text{g}) \rightarrow \text{Al}(\text{ClO}_4)_3(\text{ia}) + 3\text{H}_2\text{O}$	-498.3	-346.1
R11	$\text{HClO}_4(\text{g}) + \text{NaOH} \rightarrow \text{NaClO}_4 + \text{H}_2\text{O}$	-247.7	-203.0

^aStands for reactions involving HF(g) or HCN(g).
^bStands for alternative spontaneous reaction.
^cStands for HClO₄(ia).
^d ΔG_R at T > 240°C.
^e ΔG_R at T > 225°C.
^f ΔG_R at T > 550°C.
^g ΔG_R at T > 350°C.

Table A.4.
 SPL reactions with HClO₄(g) and their ΔH_R and ΔG_R at 30°C.

#	Reaction	ΔH_R , kJ/mol	ΔG_R , kJ/mol
27	$\text{NaCN} + 4\text{H}_2\text{O} \rightarrow [\text{Na}(\text{H}_2\text{O})_4]^+ + \text{CN}^-$	—	—
28	$\text{NaCN} + \text{H}_2\text{O} \rightarrow \text{NaOH} + \text{HCN}$	56.1	59.6
29	$\text{HCN} + \text{NaOH} \rightarrow \text{NaCN} + \text{H}_2\text{O}$	-56.1	-59.6
30	$\text{NaF} + 4\text{H}_2\text{O} \rightarrow [\text{Na}(\text{H}_2\text{O})_4]^+ + \text{F}^-$	— ^a	— ^a
31	$\text{F}^-(\text{l}) + \text{H}_2\text{O} \rightarrow \text{HF}(\text{l}) + \text{OH}^-$	—	—
32	$\text{NaAlO}_2 + 2\text{H}_2\text{O} \rightarrow \text{Na}(\text{Al}(\text{OH})_4)$	-26.1	-23.8
33	$\text{NaAlO}_2 + 2\text{H}_2\text{O} \rightarrow \text{NaOH} + \text{Al}(\text{OH})_3$	2.6	25.6
34	$\text{Na}_2\text{CO}_3 + \text{H}_2\text{O} \rightarrow 2\text{Na}^+ + (\text{CO}_3)^{2-} + \text{H}_3\text{O}^+ + (\text{OH})^-$	—	—
35	$\text{Al}_2(\text{SO}_4)_3 + 6\text{H}_2\text{O} \rightleftharpoons 2\text{Al}(\text{OH})_3 + 6\text{H}^+ + 3\text{SO}_4^{2-}$	—	—
36	$3\text{NaAlSiO}_4 + 3\text{H}_2\text{SO}_4 \rightarrow 3\text{SiO}_2 + \text{Na}_2\text{SO}_4 + \text{NaAl}_3(\text{SO}_4)_2(\text{OH})_6$	-527.5	-451.4
37	$2\text{NaAl}_3(\text{SO}_4)_2(\text{OH})_6 + 6\text{H}_2\text{SO}_4 \rightarrow 3\text{Al}_2(\text{SO}_4)_3 + \text{Na}_2\text{SO}_4 + 12\text{H}_2\text{O}$	8.9	-29.7
38	$\text{Na}_3\text{AlF}_6 + 4\text{NaOH} \rightarrow \text{NaAl}(\text{OH})_4 + 6\text{NaF}$	-164.8	-169.3
39	$2\text{NaAl}(\text{OH})_4 + 4\text{H}_2\text{SO}_4 \rightarrow \text{Al}_2(\text{SO}_4)_3 + \text{Na}_2\text{SO}_4 + 8\text{H}_2\text{O}$	-397.8	-372.1
40	$2\text{Al}(\text{OH})_3 + 3\text{H}_2\text{SO}_4 \rightarrow \text{Al}_2(\text{SO}_4)_3 + 6\text{H}_2\text{O}$	-161.1	-175.6
41	$2\text{Na}_3\text{AlF}_6 + 2\text{Al}(\text{OH})_3 + 3\text{H}_2\text{SO}_4 \rightarrow 3\text{Na}_2\text{SO}_4 + 4\text{AlF}_3 + 6\text{H}_2\text{O}$	-140.5	-147.6
42	$\text{CaF}_2 + \text{H}_2\text{SO}_4 \rightarrow \text{CaSO}_4 + 2\text{HF}(\text{l})$	+57.6	-11.6
43	$3\text{CaF}_2 + 2\text{Al}(\text{OH})_3 + 3\text{H}_2\text{SO}_4 \rightarrow 3\text{CaSO}_4 + 2\text{AlF}_3 + 6\text{H}_2\text{O}$	-185.1	-193.6

^aIonic reactions have no specific ΔH_R or ΔG_R .

Table A.5.
 Calculated ΔH_R and ΔG_R at 30°C for other potential reactions taking place during the SPL leaching process.

#	Reaction	ΔH_R , kJ/mol	ΔG_R , kJ/mol
44	$\text{Li}_3\text{AlF}_6 + \text{Al}(\text{OH})_3 + 1.5\text{H}_2\text{SO}_4 \rightarrow 1.5\text{Li}_2\text{SO}_4 + 2\text{AlF}_3 + 3\text{H}_2\text{O}$	-152.1	-158.3
45	$2\text{LiF} + \text{H}_2\text{SO}_4 \rightarrow \text{Li}_2\text{SO}_4 + 2\text{HF}(\text{g})$	64.6	-5.9
46	$2\text{Na}_3\text{Fe}(\text{CN})_6(\text{ia}) + 6\text{H}_2\text{SO}_4 \rightarrow 3\text{Na}_2\text{SO}_4 + \text{Fe}_2(\text{SO}_4)_3 + 12\text{HCN}(\text{l})$	-279.4	-365.3
47	$\text{Na}_4\text{Fe}(\text{CN})_6(\text{ia}) + 3\text{H}_2\text{SO}_4 \rightarrow 2\text{Na}_2\text{SO}_4 + \text{FeSO}_4 + 6\text{HCN}(\text{l})$	-123.3	-214.7
48	$1.5\text{MgF}_2 + \text{Al}(\text{OH})_3 + 1.5\text{H}_2\text{SO}_4 \rightarrow 1.5\text{MgSO}_4 + \text{AlF}_3 + 3\text{H}_2\text{O}$	-76.9	-83.7
49	$\text{Al}_2\text{O}_3(\text{s}) + 3\text{H}_2\text{SO}_4 \rightarrow \text{Al}_2(\text{SO}_4)_3 + 3\text{H}_2\text{O}$	-180.8	-158.7
50	$\text{Al}_4\text{C}_3 + 6\text{H}_2\text{SO}_4 \rightarrow 2\text{Al}_2(\text{SO}_4)_3 + 3\text{C} + 6\text{H}_2(\text{g})$	-1784.2	-1858.8
51	$\text{Fe}_2\text{O}_3 + 3\text{H}_2\text{SO}_4 \rightarrow \text{Fe}_2(\text{SO}_4)_3 + 3\text{H}_2\text{O}$	-178.0	-164.9
52	$\text{SiO}_2 + 4\text{HF} \rightarrow \text{SiF}_4(\text{g}) + 2\text{H}_2\text{O}$	-77.6	-101.7
53	$\text{SiO}_2 + 6\text{HF} \rightarrow \text{H}_2\text{SiF}_6(\text{ia}) + 2\text{H}_2\text{O}$	-260.7	-190.8

Table A.6.

Calculated ΔH_R and ΔG_R at 30°C for the reactions of the SPL trace constituents when subjected to H_2SO_4 leaching.

Author details

Samir I. Abu-Eishah*, Manal D.M. Raheem, Fatma A.S. Aljasmi,
Fatima M.O. Alameri, Amna G.R. Alblooshi and Intesar F.R. Alnahdi
Department of Chemical and Petroleum Engineering, United Arab Emirates
University, Al-Ain, UAE

*Address all correspondence to: s.abueishah@uaeu.ac

IntechOpen

© 2021 The Author(s). Licensee IntechOpen. This chapter is distributed under the terms of the Creative Commons Attribution License (<http://creativecommons.org/licenses/by/3.0>), which permits unrestricted use, distribution, and reproduction in any medium, provided the original work is properly cited. 

References

- [1] Courbariaux Y, Chaouki J, Guy C. Update on spent potliners treatments: Kinetics of cyanides destruction at high temperature. *Ind. Eng. Chem. Res.* 2004;43:5828-5837
- [2] Lossius L, Øye H. Melt penetration and chemical reactions in 16 industrial aluminum carbon cathodes. *Metallurgical and Materials Transactions B*, 2000;31:1213-1224.
- [3] Mikša D, Homšak M, Samec N. Spent potlining utilisation possibilities. *Waste Management & Research* 2003;21: 467-473.
- [4] Tabereaux A. The SPL waste management challenge in primary aluminum, *Light Metals Age*, March 16 2021. Available at: <https://www.lightmetalage.com/news/industry-news/smelting/the-spl-waste-management-challenge-in-primary-aluminum/>
- [5] World Aluminum, 2017. <http://www.world-Aluminum.org/statistics/>
- [6] Broek S, Øye HA. Fundamentals of managing spent potlining (SPL), *Travaux 47*, Proceedings of the 36th International Committee for Study of Bauxite, Alumina & Aluminum (ICSOBA) Conf., Belem, Brazil. Oct. 29-Nov. 1, 2018.
- [7] Sørli M, Øye HA. Cathodes in aluminum electrolysis, 3rd ed., *Aluminum-Verlag*, Dusseldorf, 2010; 662 pages, ISBN: 3942486075, 9783942486071
- [8] Cooper BJ. Considerations for dealing with spent potlining, 11th Australasian aluminum smelting technology conference, Dubai, UAE, Dec 6-11, 2014.
- [9] Lossius LP, Øye HA. Melt penetration and chemical reactions in carbon cathodes during aluminum electrolysis. II. Industrial Cathodes, *Light Metals*. 1993; 331-340.
- [10] Brisson PY, Soucy G, Fafard M, Darmstadt H, Servant G. Revisiting sodium and bath penetration in the carbon lining of aluminum electrolysis cell. *Light Metals*. 2005;727-732.
- [11] Brilloit P, Lossius L, Øye H. Penetration and chemical reactions in carbon cathodes during aluminum electrolysis: Part I. laboratory experiments. *Metallurgical & Materials Transactions B*. 1993;24:75-89.
- [12] Lisbona DF. Development of a process for the treatment of spent potlining with recovery of an Aluminum hydroxyfluoride product, PhD Thesis. The University of Nottingham, Australia, 2009.
- [13] Chanania F, Eby E. Best demonstrated available technology (BDAT) background document for spent aluminum potliners-K088, US Environmental Protection Agency, office solid waste, Washington, DC; May 31, 2000.
- [14] US5164174A. Detoxification of aluminum spent potliner by thermal treatment, lime slurry quench and post-kiln treatment, 1992.
- [15] Holywell G, Breault R. An overview of useful methods to treat, recover, or recycle spent pot lining. *Journal of the Minerals, Metals and Materials Society*. 2013;65:1441-1451.
- [16] Aldaco R, Garea A, Fernández I, Irabien Á. Fluoride reuse in aluminum trifluoride manufacture: Sustainability criteria, AIChE annual meeting, Cincinnati, OH, USA; Nov 1, 2005.
- [17] Augood DR. Some handling considerations for spent potlining, *Light Metals*. 1986;979-992.

- [18] Zhao X, Ma L. Hazardous waste treatment for spent pot liner, IOP Conf. Series: Earth Environ. Sci. 2018;108: 042023. doi: 10.1088/1755-1315/108/4/042023
- [19] Ntuk UU. Crystallization of $AlF_2OH.H_2O$ for application in the recycle of fluoride from spent pot lining (SPL), PhD Thesis. The University of Queensland, Australia; 2015.
- [20] Thonstad J, Fellner P, Haarberg GM, Hives J, Kvarde H, Sterten A. Aluminum Electrolysis: Fundamentals of the Hall-Héroult Process, Aluminium-Verlag, 2001. 359 pages
- [21] Mansfield K, Harple, J, Swayn G. SPL treatment and fluoride recycling project. 2002;315-327.
- [22] Grobelny M. High temperature crystallization of aluminum fluoride. Course, hydrolysis, solid phases. Journal of Fluorine Chemistry. 1977;9: 187-207.
- [23] Pong TK, Adrien RJ, Besida J, O'Donnell TA, Wood DG. Spent Potlining – A hazardous waste made safe. Process Safety and Environmental Protection. 2000;78:204-208.
- [24] Sanjuan B, Michard G. Aluminum hydroxide solubility in aqueous solutions containing fluoride ions at 50° C. Geochimica et Cosmochimica Acta. 1987;51:1823-1831.
- [25] Grolman RJ, Holywell GC, Kimmerle FM. Recycling of spent pot linings. US Patent 5470559A , 1995.
- [26] Lisbona DF, Steel KM. Treatment of spent pot-lining for recovery of fluoride values. Light Metals- Warrendale-Proceedings-the Minerals, Metals & Materials Society. 2007;843–848. ISSN: 0147-0809
- [27] Lisbona DF, Somerfield C, Steel KM. Leaching of spent pot-lining with aluminum nitrate and nitric acid: Effect of reaction conditions and thermodynamic modelling of solution speciation, Hydrometallurgy. 2013; 134-135:132-143
- [28] Bishoyi N. Treatment of Spent Pot Lining by Chemical Leaching Using Nitric Acid for Enrichment of its Fuel Value and Optimization of the Process Parameters, B.Sc Thesis; National Institute of Technology, Rourkela, India, 2015.
- [29] Shi Z-N, Li W, Hu X-W, Ren B-J, Gao B-L, Wang Z-W. Recovery of carbon and cryolite from spent pot lining of aluminum reduction cells by chemical leaching. Trans. Nonferrous Met. Soc. China. 2012;22:222-227.
- [30] Parhi SS, Rath P. Gainful Utilization of Spent Pot Lining - a Hazardous Waste from Aluminum Industry, Master Thesis, National Institute of Technology, Rourkela, Odisha, India; August 2014.
- [31] Zhao LC. Process for recovering waste liner of Aluminum electrolyzer. CN1320491A, 2001-11-07.
- [32] Cao X-Z, Shi Y-Y, Zhao S, Xue X-X. Recovery of valuable components from spent pot-lining of aluminum electrolytic reduction cells, Journal of Northeastern University. 2014;35:1746–1749. DOI: 10.3969/j. issn.1005-3026.2014.12.017
- [33] Li X, Yin W, Fang Z, Liu Q, Cui Y, Zhao J, Jia H. Recovery of carbon and valuable components from spent pot lining by leaching with acidic aluminum anodizing wastewaters, Metallurgical and Materials Transactions B, 2019;50: 914–923.
- [34] Ntuk U, Tait S, White ET, Steel KM. The precipitation and solubility of aluminum hydroxyfluoride hydrate between 30-70°C, Hydrometallurgy. 2015;155:79–87.

- [35] Lisbona D, Steel K. Recovery of fluoride values from spent pot-lining: Precipitation of an aluminum hydroxyfluoride hydrate product. *Separation and Purification Technology*. 2008;61:182–192.
- [36] Ketcheson K, Fingas M. Sodium cyanide: Properties, toxicity, uses and environmental impacts. In: *The Handbook of Hazardous Materials Spills Technology*, New York: McGraw Hill; 2002. p. 39.1-39.22. ISBN: 007135171X 9780071351713
- [37] NCABrasil Expert Auditors Ltd. Cyanide Production Operation, Summary Audit Report for Proguigel Chuimica S/A, CandeiasUnit/2016. Available at: <https://www.cyanidecode.org/sites/default/files/pdf/ProquigelCandeiasSAR2017.pdf>
- [38] Available at Inorganic acids and bases - pKa values (engineeringtoolbox.com)
- [39] Stoffregen RE, Alpers CN, Jambor JL. Alunite-Jarosite crystallography, Thermodynamics, and Geochronology, *Reviews in Mineralogy and Geochemistry*. 2000;40:453-479.
- [40] Annoni R, Souza PS, Petrániková M, Miskufova A, Havlik T, Mansur MB, Submerged-arc welding slags: Characterization and leaching strategies for the removal of aluminum and titanium, *Journal of Hazardous Materials*. 2013;244-245:335-341. DOI: 10.1016/j.jhazmat.2012.11.053
- [41] Kaaber H, Mollgaard M. Process for recovering aluminum and fluorine from fluorine containing waste materials. US Patent 5,558,847, 1996.
- [42] Chelgani SC, Rudolph M, Kratzsch R, Sandmann D, Gutzmer J. A review of graphite beneficiation techniques, *Mineral Processing and Extractive Metallurgy Review*. 2016;37: 58-68.
- [43] Turton R, Bailie RC, Whiting WB, Shaeiwitz JA, Bhattacharyya D. *Analysis, Synthesis and Design of Chemical Engineering Processes*, 4th ed., NY: Prentice Hall; 2012. 1104 p. ISBN-13: 978-0-13-261812-0
- [44] Indicative Chemical Prices A-Z. Available at: <https://www.icis.com/explore/chemicals/channel-info-chemicals-a-z/>