



6-2019

Analysis of an Eco-Epidemiological Model under Optimal Control Measures for Infected Prey

Alfred Hugo
University of Dodoma

Emanuel Simanjilo
University of Dodoma

Follow this and additional works at: <https://digitalcommons.pvamu.edu/aam>



Part of the [Control Theory Commons](#), [Other Physics Commons](#), and the [Social and Behavioral Sciences Commons](#)

Recommended Citation

Hugo, Alfred and Simanjilo, Emanuel (2019). Analysis of an Eco-Epidemiological Model under Optimal Control Measures for Infected Prey, *Applications and Applied Mathematics: An International Journal (AAM)*, Vol. 14, Iss. 1, Article 8.

Available at: <https://digitalcommons.pvamu.edu/aam/vol14/iss1/8>

This Article is brought to you for free and open access by Digital Commons @PVAMU. It has been accepted for inclusion in *Applications and Applied Mathematics: An International Journal (AAM)* by an authorized editor of Digital Commons @PVAMU. For more information, please contact hvkoshy@pvamu.edu.



Analysis of an Eco-Epidemiological Model under Optimal Control Measures for Infected Prey

¹Alfred Hugo and ²Emanuel Simanjilo

Department of Mathematics
University of Dodoma
P. O. Box 338
Dodoma, Tanzania

alfredhugo@gmail.com; e.simanjilo@yahoo.com;

Received: March 20, 2018; Accepted: March 4, 2019

Abstract

This paper examines the analysis of an eco-epidemiological model with optimal control strategies for infected prey. A model is proposed and analyzed qualitatively using the stability theory of the differential equations. A local and global study of the model is performed around the disease-free equilibrium and the endemic equilibrium to analyze the global stability using the Lyapunov function. The time-dependent control is introduced into the system to determine the best strategy for controlling the disease. The results obtained suggested the separation of the infected population plays a vital role in disease elimination.

Keywords: Predator-prey system; Eco-epidemiology; optimal control

MSC 2010 No.: 70k, 93A30, 91B70

1. Introduction

Ecology and epidemiology are two major and distinct fields of study. However, there are situations where some diseases which are responsible for an epidemic, have a strong impact on the dynamics of ecological systems (Raid et al. (2012)). Eco-epidemiology is basically a branch of mathematical biology which considers both the ecological and epidemiological issues concurrently. The first breakthrough in modern mathematical ecology was done by (Lotka (1924)) for a predator-prey competing species. On the other hand, most of the models for the transmission of infectious diseases originated from the classic work of (Kermack et al. (1927)). In the modern era, there is an increase in the number of works that describes the relationships between demographic processes among different populations and diseases. Mathematical biologists have been working on merging

the ecology and Epidemiology (Pan (2013), Zhou et al. (2013), Jiano et al. (2008), Hethcote (2000)). Diseases that affect the prey populations, in particular, may affect the entire predator-prey system (Mukhopadhyaya et al. (2009), Jana et al. (2013), Gani (2013)). Not only has the disease in the system affected the dynamics of prey population, but also prey-predator interactions. Controlling diseases in the prey-predator system are crucial and vital aspect of the ecosystem for coexistence and stability in nature.

The time-dependent control measures are put in place to curtail the spread of disease in population which described with mathematical control theory. This theory describes the principle that underlies the analysis and design of the control system which used to influence the behavior of objects for the specific goal (Sontag (1998)). The optimal control theory plays an important role in decision making regarding intervention programs (Okosun et al. (2011)). Modeling infectious diseases in species provide an important insight into disease behavior and control measures and provide essential elements in evaluating the relevance of the intervention programs.

The interaction between human and animals or among animals themselves may result in disease transmission which destabilizes the ecosystem. The studies by (Bornaa et al. (2015), Elettrey et al. (2015), Hugo et al. (2012), Mukhopadhyay et al. (2009), Tengaa et al. (2015)) employed modeling techniques to analyze an ecological aspect of interacting species of various animals. In this paper, the eco-epidemiological model with optimal control measures put into consideration for ensuring prey-predator populations coexists in a defined habitat.

2. Model Formulation

A mathematical model is proposed and analyzed to study the functional response analysis of the predator toward the susceptible prey as well as infected prey. These dynamics are assumed to follow Michaelis-Menten kinetics Holling type-II predation function (Mukhopadhyay et al. (2009), Hugo et al. (2012)). The model consists of prey population density denoted by $N_1(t) = S(t) + I(t)$ and the predator population density denoted by $Y(t)$.

We impose the following assumptions in formulating mathematical model.

- i) In the absence of disease, the prey population grows logistically with intrinsic growth rate r and environmental carrying capacity k .
- ii) In the presence of disease, the prey consists of two subclasses, namely, the susceptible prey $S(t)$ and the infected prey $I(t)$.
- iii) Only the susceptible prey can reproduce. The logistic law is used to model the birth process with the assumption that births should always be positive. The infected prey is removed with natural death rate e_1 , death caused by disease a_1 or by predation. However, the infected prey population I contribute with S to population growth towards the carrying capacity.
- iv) It is assumed that the disease is spread among the prey population only.
- v) Susceptible prey becomes infected when it comes in contact with the infected prey and this contact process is assumed to follow the simple mass action kinetics with β as the rate of transmission.
- vi) The predator population suffers loss due to death at a constant rate e_2 . The predation functional response of the predator towards susceptible as well as infected prey are assumed to follow Michaelis–Menten kinetics and is modelled using a Holling type-II

functional form with predation coefficient p_1 , p_2 and half-saturation constant m . Consumed prey is converted into predator with efficiency q .

- vii) $0 \leq u_1 \leq 1$, is the control rate (by separation) of infected and susceptible prey.
- $0 \leq u_2 \leq 1$, is the control rate by separating susceptible predator from infected prey.

Now, we transform the above assumptions to form the following schematic flow diagram:

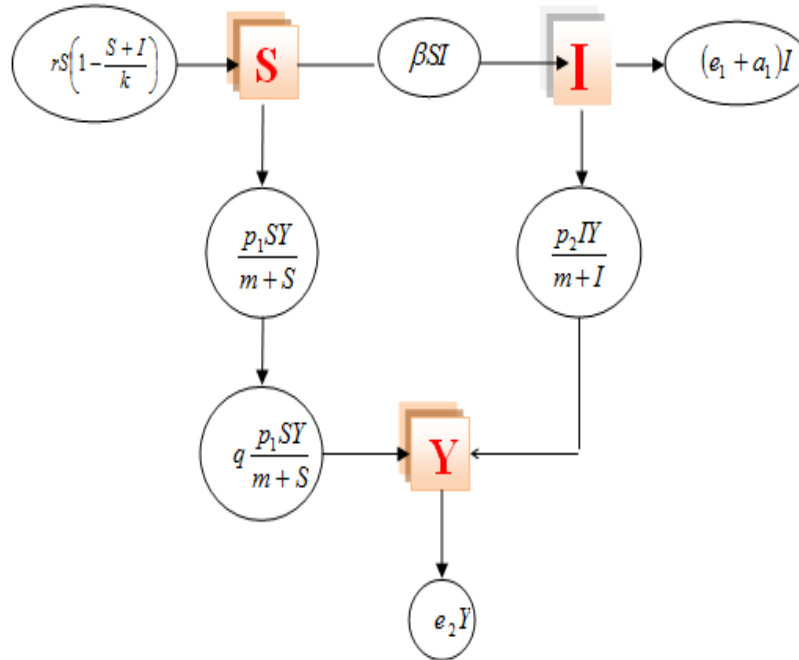

Figure 1. Model Flowchart

From Figure 1, the mathematical model will be governed by the following system of the equations

$$\begin{aligned}
 \frac{dS}{dt} &= rS\left(1 - \frac{S+I}{k}\right) - \beta SI - \frac{p_1SY}{m+S}, \\
 \frac{dI}{dt} &= \beta SI - \frac{p_2IY}{m+I} - (a_1 + e_1)I, \\
 \frac{dY}{dt} &= q \frac{p_1SY}{m+S} + \frac{p_2IY}{m+I} - e_2Y,
 \end{aligned}
 \tag{1}$$

with the initial conditions:

$$S(0) = S_0 > 0, I(0) = I_0 > 0, Y(0) = Y_0 > 0, p_1, p_2 > 0, 0 \leq u_1, u_2 \leq 1 \text{ and } 0 < q \leq 1.$$

3. Model Analysis

The mathematical model (1) is qualitatively analyzed to obtain the dynamical features to understand the dynamics of the disease in the prey population.

3.1. Boundedness of the model

In the theoretical eco-epidemiology, the boundedness of the system implies that the system is biologically valid and well behaved (Hugo et al. (2012)). In this section, we show how the model is biological valid by providing the boundedness of the solution of the model through the following theorem (Mukhopadhyay et al. (2009)).

Theorem 1.

All solutions of the system (1) are uniformly bounded.

Proof:

Assume W denote the total population in the specific model, that is,

$$W = S + I + Y. \quad (2)$$

This gives,

$$\frac{dW}{dt} = \frac{dS}{dt} + \frac{dI}{dt} + \frac{dY}{dt}. \quad (3)$$

Substituting the model equations (1) into (3) and simplifying, we obtain

$$\begin{aligned} \frac{dW}{dt} &\leq rS - (a_1 + e_1)I - e_2Y, \\ &\leq S(r+1) - S - (a_1 + e_1)I - e_2Y, \\ &\leq \hat{k}(r+1) - hW, \end{aligned} \quad (4)$$

where

$$\hat{k} = \max\{S(0), k\} \text{ and } h = \min\{1, e_1 + a_1, e_2\}. \quad (5)$$

Then,

$$\frac{dW}{dt} + hW \leq \hat{k}(r+1). \quad (6)$$

Solving equation (6) and substituting the initial conditions we get

$$W \leq \frac{\hat{k}}{h}(r+1)(1 - e^{-ht}). \quad (7)$$

As $t \rightarrow \infty$, we have

$$W \leq \frac{\hat{k}}{h}(r+1), \text{ which implies that the solution is bounded for}$$

$$0 \leq W \leq \frac{\hat{k}}{h}(r+1).$$

Therefore, all solutions of the model (1) in \mathfrak{R}_+^3 are confined to the region

$$\Gamma = \left\{ (S, I, Y) \in \mathfrak{R}_+^3 : W \leq \frac{\hat{k}}{h}(r+1) + \varepsilon \right\} \text{ for all } \varepsilon > 0 \text{ and } t \rightarrow \infty. \tag{8}$$

3.2. Positivity of Solutions

For model (1) to be epidemiologically meaningful and well posed, we need to prove that all solutions of the system with positive initial data will remain positive for all times $t > 0$ (Hugo et al. (2012)). See the following theorem

Theorem 2.

Let $S(0) > 0, I(0) > 0, Y(0) > 0$. This implies that the solutions $S(t), I(t)$ and $Y(t)$ of the model (1) are all positive $\forall t \geq 0$.

Proof:

To prove Theorem, we use all the equations of the model (1). From the 1st equation, we obtain the inequality expression as

$$\frac{dS}{dt} \leq rS \left(1 - \frac{S}{k} \right), \text{ which can be simplified to give}$$

$$S \leq \frac{kS(0)}{e^{-rt}(k - S(0)) + S(0)}. \tag{9}$$

Now, as $t \rightarrow \infty$ we obtain $0 < S \leq k$. Hence, the solution of system (1) is feasible in the region $\Gamma = \{S, I, Y\}$.

Similar proofs for the reaming equations of the model can be established following a similar approach.

4. Equilibria and Stability analysis

4.1. Equilibrium Points

The model equations (1) has the following different equilibrium points through setting,

$$\frac{dS}{dt} = \frac{dI}{dt} = \frac{dY}{dt} = 0. \quad (10)$$

The model equations (1) possesses the following equilibrium points

- (i) The axial equilibrium $E_A(k, 0, 0)$, where the predator and infected prey populations die out while leaving susceptible prey to growth to its carrying capacity.
- (ii) The boundary equilibrium point where the predator population dies out, that is

$$Y^* = 0 \left(S^*, I^*, Y^* \right) = E_Y \left(\frac{a+e_1}{\beta}, I^* = \frac{(m\beta+a_1+e_1)r(k\beta-a_1-e_1)}{\beta(r+k\beta)(\beta m+a_1+e_1)+k\beta^2 p_1}, 0 \right),$$

which exist if and only if $\frac{k\beta}{a_1+e_1} > 1$.

- (iii) The boundary equilibrium point where the disease eventually disappears from the prey population that is

$$\left(S^*, I^*, Y^* \right) = E_I \left(\frac{me_2}{qp_1 - e_2}, 0, rmq \left(\frac{kqp_1 - ke_2 - me_2}{k(qp_1 - e_2)^2} \right) \right),$$

which will exist if $e_2 < qp_1$ and $\frac{kqp_1}{k+m} > e_2$.

- (iv) An endemic positive equilibrium point (S^*, I^*, Y^*) is obtain when

$$r \left(1 - \frac{S+I}{k} \right) - \beta I - \frac{p_1 Y}{m+S} = 0, \quad (11)$$

$$\beta S - \frac{p_2 Y}{m+I} - (a_1 + e_1) = 0, \quad (12)$$

$$q \frac{p_1 S}{m+S} + \frac{p_2 I}{m+I} - e_2 = 0. \quad (13)$$

Now, solving (12) and (13) simultaneously we get

$$S^* = \frac{m(me_2 + e_2 - p_2)I^*}{mqp_1 + (qp_1 - me_2 - e_2 + p_2)I^*}, \quad (14)$$

$$Y^* = \frac{B}{p_2(mqp_1 - me_2 + (qp_1 + p_2 - e_2))I^*}, \tag{15}$$

where

$$B = m\beta p_2 I^{*2} - m\beta e_2 I^* - 2m^2 I^* e_2 \beta + m^2 p_2 \beta I^* + 2a_1 qp_1 m I^* + 2e_1 m qp_1 I^* + me_1 p_2 I^* + ma_1 p_2 I^* - a_1 e_2 I^{*2} - m^2 e_1 e_2 - m^2 a_1 e_2 - e_1 e_2 I^{*2} - m^3 e_2 \beta + qa_1 p_1 I^{*2} + a_1 p_2 I^{*2} - 2a_1 e_2 m I^* + m^2 e_1 qp_1 - 2e_1 m e_2 I^* + m^2 a_1 qp_1 + qp_1 e_1 I^{*2} + e_1 p_2 I^{*2}.$$

where I^* is the positive root of the equation

$$r(k - S^*)(m + S^*) - (r - k\beta)(m + S^*)I - kp_1 Y^* = 0. \tag{16}$$

4.2. Local Stability analysis

We determine the local stability of the equilibria by computing the Jacobian Matrix of the model equations (1) and study the existence criteria of each equilibrium point.

This gives

$$J_{(S^*, I^*, Y^*)} = \begin{bmatrix} A - \frac{p_1 Y^*}{m + S^*} + \frac{p_1 S^* Y^*}{(m + S^*)^2} & -\frac{rS^*}{k} - \beta S^* & -\frac{p_1 S^*}{m + S^*} \\ \beta I^* & \beta S^* - a_1 - e_1 - \frac{p_2 Y^*}{m + I^*} + \frac{p_2 I^* Y^*}{(m + I^*)^2} & -\frac{p_2 I^*}{m + I^*} \\ \frac{qp_1 Y^*}{m + S^*} - \frac{qp_1 S^* Y^*}{(m + S^*)^2} & \frac{p_2 Y^*}{m + I^*} - \frac{p_2 I^* Y^*}{(m + I^*)^2} & \frac{qp_1 S^*}{m + S^*} + \frac{p_2 I^*}{m + I^*} - e_2 \end{bmatrix}, \tag{17}$$

where

$$A = r \left(1 - \frac{S^* + I^*}{k} \right) - \frac{rS^*}{k} - \beta I^*.$$

Theorem 3.

The axial equilibrium point $E_A(k, 0, 0)$ is locally asymptotically stable if

$$1 < \frac{a_1 + e_1}{k\beta} \Rightarrow \frac{k\beta}{a_1 + e_1} \quad \text{and} \quad q < \frac{e_2(m + k)}{p_1 k}. \tag{18}$$

Proof:

The Eigenvalues of the equilibrium E_A are given by

$$\eta_1 = -r, \quad \eta_2 = k\beta - a_1 - e_1, \quad \eta_3 = \frac{qp_1k - (m+k)e_2}{m+k}. \quad (19)$$

Then, for stability, we need to have

$$\eta_2 < 0 \text{ if } k\beta < a_1 + e_1$$

and

$$\eta_3 < 0 \text{ if } qp_1k < (m+k)e_2.$$

Biological Meaning: If feeding efficiency of predator is low such that $\frac{qp_1k}{m+k} < e_2$ the predator species will extinct and prey population will reach its carrying capacity k .

Theorem 4.

The boundary equilibrium point $E_Y = (S^*, I^*, 0)$ where the predator population dies out, is locally asymptotically stable iff $r(a_1 + e_1) > A_1$ and $\eta_1, \eta_2, \eta_3 < 0$, where

$$\eta_1 = -\frac{r(a_1 + e_1) - A_1}{2k\beta},$$

$$\eta_2 = -\frac{r(a_1 + e_1) + A_1}{2k\beta},$$

$$\eta_3 = -\left[\frac{qp_1ra_1^2 + rp_2e_1^2 + rp_2a_1^2 + qp_1re_1^2 - e_2re_1^2 + e_2m^2\beta^2r + e^2m^2\beta^3k + e_2mrk\beta^2 + e_2a_1m\beta^2k + e_2a_1rk\beta - 2e_2a_1re_1 - e_2ra_1^2 + e_2e_1m\beta^2k - qp_1a_1mr\beta - qp_1a_1mk\beta^2 - qp_1a_1rk\beta - qp_1e_1mr\beta + 2rp_2a_1e_1 + rp_2e_1m\beta - qp_1e_1mk\beta^2 - qp_1e_1rk\beta - rp_2m\beta^2k - rp_2a_1k\beta - rp_2e_1k\beta}{m^2\beta^2r + m^2\beta^3k + m\beta^2rk + a_1m\beta^2k + a_1r\beta k - ra_1^2 - 2a_1re_1 + e_1m\beta^2k + e_1rk\beta - re_1^2} \right], \quad (20)$$

where

$$A_1 = \sqrt{r(a_1 + e_1)(ra_1 + 4a_1u_1k\beta + re_1 - 4k^2\beta^2u_1^2 + 4e_1u_1k\beta)}.$$

Biological Meaning: If predator population will die out, the prey population will grow logistically but the disease will remain endemic in prey.

Theorem 5.

The disease free equilibrium point $E_I = (S^*, 0, Y^*)$ will be locally asymptotically stable if $e_2 < qp_1$ and $2qp_1e_2 < q^2 p_1^2 + e_2$.

Proof:

The Eigenvalues of $E_I = (S^*, 0, Y^*)$ are given by

$$\eta_1 = \frac{A_3}{2qp_1k(e_2 - qp_1)}, \tag{21}$$

$$\eta_2 = \frac{A_3}{2qp_1k(e_2 - qp_1)}, \tag{22}$$

$$\eta_3 = -\frac{A_4}{k(q^2 p_1^2 - 2qp_1e_2 + e_2^2)}, \tag{23}$$

where

$$A_3 = e_2^3rk + e_2^2rm - rqkp_1e_2 + rqp_1e_2m - \text{sqrt}(e_2rB_1) \text{ and} \tag{24}$$

$$B_1 = \left\{ \begin{array}{l} e_2^3rk^2 + 2e_2^3rmk - 2e_2^2rk^2qp_1 + e_2^3rm^2 + 2e_2^2rm^2qp_1 + rq^2k^2p_1^2e_2 \\ -2rq^2kp_1^2e_2m + rq^2p_1^2e_2m^2 + 4qp_1e_2^3k^2 + 4qp_1e_2^3km - 12q^2p_1^2e_2^2k^2 \\ -8q^2p_1^2e_2^2km + 12q^3p_1^3e_2^2k^2 + 4q^3p_1^3e_2km - 4q^4p_1^4k^2 \end{array} \right\} \tag{25}$$

$$A_4 = q^2 p_1^2 a_1 k + q^2 p_1^2 e_1 k + q^2 u_2 p_2 r k p_1 - q p_1 u_1 \beta e_2 m k - 2 q p_1 a_1 k e_2 - 2 q p_1 e_1 k e_2 - q u_2 p_2 r e_2 k - q u_2 p_2 r e_2 m + u_1 \beta e_2^2 m k + a_1 k e_2^2 + e_1 k e_2^2. \tag{26}$$

Biological Meaning: The feeding efficiency of predator is so high that $e_2 < qp_1$ this is because of the absence of the disease and predator will only feed on health prey.

The stability analysis around the coexistence equilibrium point is determined by substituting (S^*, I^*, Y^*) in the Jacobian matrix (17), and we obtain

$$J_{(S^*, I^*, Y^*)} = \begin{bmatrix} A_1 - \lambda & -A_2 & -A_3 \\ \beta I^* & A_4 - a_1 - e_1 - \lambda & -A_5 \\ A_6 & A_7 & A_8 - e_2 - \lambda \end{bmatrix}, \tag{27}$$

where

$$A_1 = r \left(1 - \frac{S^* + I^*}{k} \right) - \frac{rS^*}{k} - \beta I^* - \frac{p_1 Y^*}{m + S^*} + \frac{p_1 S^* Y^*}{(m + S^*)^2}, \tag{28}$$

$$A_2 = \frac{rS^*}{k} + \beta S^*, \quad A_3 = \frac{p_1 S^*}{m + S^*}, \quad A_4 = \beta S^* - \frac{p_2 Y^*}{m + I^*} + \frac{p_2 I^* Y^*}{(m + I^*)^2}, \quad (29)$$

$$A_5 = \frac{p_2 I^*}{m + I^*}, \quad A_6 = \frac{qp_1 Y^*}{m + S^*} - \frac{qp_1 S^* Y^*}{(m + S^*)^2}, \quad A_7 = \frac{p_2 Y^*}{m + I^*} - \frac{p_2 I^* Y^*}{(m + I^*)^2}, \quad (30)$$

$$A_8 = \frac{qp_1 S^*}{m + S^*} + \frac{p_2 I^*}{m + I^*}. \quad (31)$$

This yields the following polynomial equation

$$\lambda^3 + B_1 \lambda^2 + B_2 \lambda + B_3 = 0, \quad (32)$$

where

$$B_1 = 3I - A_8 - A_4 + a_1 - A_1 + e_2 + e_1, \quad (33)$$

$$B_2 = 3I^2 - (2A_8 - \beta A_2 - 2a_1 + 2A_4 - 2e_2 + 2A_1 - 2e_1)I + A_4 A_1 - e_2 A_1 + e_2 a_1 + A_7 A_5 + A_8 A_1 - a_1 A_1 - A_8 e_1 + e_2 e_1 + A_6 A_3 + A_8 A_4 - e_2 A_4 - e_1 A_1 - A_8 a_1, \quad (34)$$

$$B_3 = I^3 - (A_8 - e_2 + A_1 + A_4 - a_1 - e_1 - \beta A_2)I^2 - \left(e_1 A_1 + a_1 A_1 - A_7 A_5 - A_4 A_1 - A_8 A_4 + A_8 a_1 + A_8 e_1 - e_2 e_1 - A_8 A_1 \right) I + \left(+e_2 A_4 - e_2 a_1 - A_6 A_3 + e_2 A_1 + \beta A_7 A_3 - \beta A_8 A_2 + \beta e_2 A_2 + e_2 A_4 A_1 - A_8 A_4 A_1 - A_7 A_5 A_1 + A_6 A_3 e_1 - e_2 e_1 A_1 - A_6 A_3 A_4 - e_2 a_1 A_1 - A_6 A_2 A_5 + A_6 A_3 a_1 + A_8 e_1 A_1 + A_8 a_1 A_1 \right) \quad (35)$$

Using the Routh-Hurwitz criteria, the coexistence equilibrium point will be stable if the equation (32) will obey $B_1 > 0$, $B_2 > 0$, $B_3 > 0$, $B_1 B_2 > B_3$. Otherwise, the coexistence equilibrium point is unstable.

4.3. Global stability analysis

We perform a global stability analysis of the system (1) around the positive equilibrium point $E(S^*, I^*, Y^*)$ of the coexistence. The following theorem of Lyapunov function U is considered.

Theorem 6.

Let,

$$U = \frac{1}{2}(S - S^*)^2 + \frac{1}{2}\mu_1(I - I^*)^2 + \frac{1}{2}\mu_2(Y - Y^*)^2, \quad (36)$$

where $\mu_1, \mu_2 > 0$ are to be carefully chosen such that $U'(E) = 0$ then, $E(S^*, I^*, Y^*)$ and

$$U = (S, I, Y) > 0 \quad \forall S, I, Y \in \{E\}.$$

If the time derivative of U is

$$\frac{dU}{dt} \leq 0, \quad \forall S, I, Y \in \Gamma^+.$$

Then, it follows that

$$\frac{dU}{dt} = 0, \quad \forall S, I, Y \in \Gamma^+$$

implies that E^* of the system is Lyapunov stable and

$$\frac{dU}{dt} < 0 \quad \forall S, I, Y \in \Gamma^+, \text{ near } E^* \text{ implies that } E^* \text{ is globally stable.}$$

Proof:

$$\frac{dU}{dt} = (S-S^*) \frac{dS}{dt} + \mu_1 (I-I^*) \frac{dI}{dt} + \mu_2 (Y-Y^*) \frac{dY}{dt}, \tag{37}$$

Now by substituting the model equations (1), we get

$$\begin{aligned} \frac{dU}{dt} = & (S-S^*) \left\{ rS \left(1 - \frac{S+I}{k} \right) - \beta SI - \frac{p_1 SY}{m+S} \right\} \\ & + \mu_1 (I-I^*) \left\{ \beta SI - \frac{p_2 IY}{m+I} - (a_1 + e_1) I \right\} \\ & + \mu_2 (Y-Y^*) \left\{ q \frac{p_1 SY}{m+S} + \frac{p_2 IY}{m+I} - e_2 Y \right\}. \end{aligned} \tag{38}$$

Then, equation (38) becomes

$$\begin{aligned} \frac{dU}{dt} = & (S-S^*) \left\{ r \left(1 - \frac{S+I}{k} \right) - \beta I - \frac{p_1 Y}{m+S} \right\} \{S-S^*\} \\ & + \mu_1 (I-I^*) \left\{ \beta S - \frac{p_2 Y}{m+I} - (a_1 + e_1) \right\} \{I-I^*\} \\ & + \mu_2 (Y-Y^*) \left\{ q \frac{p_1 S}{m+S} + \frac{p_2 I}{m+I} - e_2 \right\} \{Y-Y^*\}. \end{aligned} \tag{39}$$

By rearranging we obtain

$$\begin{aligned} \frac{dU}{dt} = & -(S-S^*)^2 \left\{ r \left(-1 + \frac{S+I}{k} \right) + \beta I + \frac{p_1 Y}{m+S} \right\} \\ & - \mu_1 (I-I^*)^2 \left\{ -\beta S + \frac{p_2 Y}{m+I} + (a_1 + e_1) \right\} \\ & - \mu_2 (Y-Y^*)^2 \left\{ -q \frac{p_1 S}{m+S} - \frac{p_2 I}{m+I} + e_2 \right\}. \end{aligned}$$

Thus, it is possible to set $\mu_1, \mu_2 > 0$ such that $U' \leq 0$ an endemic positive equilibrium point is globally stable. Therefore, it is noted that the parameters k , m and q play important roles in controlling the stability aspects of the system (Hugo et al. (2012)).

5. Application of Optimal Control to prey-predator system

The time-dependent control has been introduced in the model equations (1) with the aim of controlling the disease transmission among prey populations and separating predator population from infected prey. The dynamics are formulated as an optimal control with the following assumptions. It is assumed that a fraction of susceptible prey populations are been infected the rate $(1-u_1)\beta SI$ while others remain in susceptible class. Then, the control rate through separation of infected and susceptible prey $(u_1(t))$ varies with time and it will be at the optimal level whenever $u_1(t) = 1$ and less effective when $u_1(t) = 0$. We also assume that the predator populations could be infectious by the fraction $\frac{(1-u_2)p_2 IY}{m+I}$ and the remaining fraction retained as susceptible populations. The predator population has been controlled by separating predator from infected prey $(u_2(t))$ and will be at the optimal level whenever $u_2(t) = 1$ and less effective when $u_2(t) = 0$.

The modified model (1) by incorporating time-dependent control is given by:

$$\begin{aligned} \frac{dS}{dt} &= rS \left(1 - \frac{S+I}{k} \right) - (1-u_1)\beta SI - \frac{p_1 SY}{m+S}, \\ \frac{dI}{dt} &= (1-u_1)\beta SI - \frac{(1-u_2)p_2 IY}{m+I} - (a_1 + e_1)I, \\ \frac{dY}{dt} &= q \frac{p_1 SY}{m+S} + \frac{(1-u_2)p_2 IY}{m+I} - e_2 Y. \end{aligned} \tag{40}$$

The inner behavior of the model with control is analyzed based on the application of control theory as a mathematical tool which is essential for decision making of the best strategy that can save the population to extinction. The behavior of the prey-predator system with varying capacity was critically analyzed by (Chaity et al. (2017)) and the application of the optimal control scenario was deeply described by (Lenhart et al. (2007)). The introduced controls of the system usually intend to determine the optimal level of the intervention strategy preferred to reduce the spreads of the

disease among prey and predator populations. Further, we assume that the separation controls has limitations with a maximum rate of control in a given time period T. The control boundedness must satisfy the Lebesgue measurable control as

$$U = \{u = (u_1, u_2), 0 \leq u_i \leq u_{i_{\max}}, i = 1, 2\}.$$

The intention is to minimize the number of infected prey populations through the following objective functional

$$J = \min_{u_1, u_2} \int_0^{t_f} \left(BI + \frac{1}{2} A_1 u_1^2 + \frac{1}{2} A_2 u_2^2 \right) dt, \tag{41}$$

where t_f is the final time, BI is the cost associated with the separation of infected prey from susceptible prey population while A_1 and A_2 are relative cost weight for each individual control measure. The objective function (41) involved in minimizing the number of contacts between infected prey from susceptible prey and predator populations. We apply the quadratic function in objective function as it satisfies the optimality conditions (Massawe et al. (2015), Mpeshe et al. (2014), Okosun et al. (2013), Okosun et al. (2011), Tchuente et al. (2011)). Then, the optimal controls $u_1^*(t)$ and $u_2^*(t)$ exists such that

$$J(u_1^*(t), u_2^*(t)) = \min \{J(u_1(t), u_2(t)) | u_1(t), u_2(t) \in U\},$$

where

$$U = \{(u_1(t), u_2(t))\} \text{ are measurable,}$$

$$a_i \leq (u_1(t), u_2(t)) \leq b_i, i = 1, \dots, 3 \quad a_i = 0, b_i = 1, t \in [0, t_f] \text{ is the closed set.}$$

The necessary conditions that are formulated by Pontryagin’s Maximum (Lenhart et al. (2007)) need to be satisfied with the formulated model. The Pontryagin’s Maximum Principle usually converts the system of equation (40) and (41) into a problem of minimizing point-wise a Hamiltonian (H), with respect to $u_1(t), u_2(t)$ as

$$\begin{aligned} H = & BI + \frac{1}{2} A_1 u_1^2 + \frac{1}{2} A_2 u_2^2 \\ & + \lambda_1 \left\{ r \left(1 - \frac{S+I}{k} \right) S - (1-u_1) \beta SI - \frac{p_1 SY}{m+S} \right\} \\ & + \lambda_2 \left\{ (1-u_1) \beta SI - (a_1 + e_1) I - \frac{(1-u_2) p_2 IY}{m+I} \right\} \\ & + \lambda_3 \left\{ \frac{p_1 q SY}{m+S} + \frac{(1-u_2) p_2 IS}{m+I} - e_2 Y \right\}, \end{aligned} \tag{42}$$

where λ_i , $i = 1, 2, 3, 4, 5$ are the co-state variables associated with, I , Y . The adjoint equations are obtained by

$$\frac{d\lambda_i}{dt} = -\frac{\partial H}{\partial i}, \quad (43)$$

with transversality condition

$$\lambda_i(t_f) = 0. \quad (44)$$

From (42) we obtain the following adjoint equations

$$\begin{aligned} \frac{\partial H}{\partial S} = & -\lambda_1 \left(-\frac{rS}{k} + r \left(1 - \frac{S+I}{k} \right) - (1-u_1)\beta I - \frac{p_1 Y}{m+S} + \frac{p_1 SY}{(m+S)^2} \right) - \lambda_2 (1-u_1)\beta I \\ & - \lambda_3 \left(\frac{p_1 q Y}{m+S} - \frac{p_1 q SY}{(m+S)^2} \right), \end{aligned} \quad (45)$$

$$\begin{aligned} \frac{\partial H}{\partial I} = & -B - \lambda_1 \left(-\frac{rS}{k} - (1-u_1)\beta S \right) - \lambda_3 \left(\frac{(1-u_2)p_2 Y}{m+I} - \frac{(1-u_2)p_2 IY}{(m+I)^2} \right) \\ & - \lambda_2 \left((1-u_1)\beta S - \frac{(1-u_2)p_2 Y}{m+I} + \frac{(1-u_2)p_2 IY}{(m+I)^2} - a_1 - e_1 \right), \end{aligned} \quad (46)$$

$$\frac{\partial H}{\partial Y} = \frac{\lambda_1 p_1 S}{m+S} + \frac{\lambda_2 (1-u_2) p_2 I}{m+I} - \lambda_3 \left(\frac{p_1 q S}{m+S} + \frac{(1-u_2) p_2 I}{m+I} - e_2 \right). \quad (47)$$

The optimality of the control problem is obtained by

$$u_i^*(t) = \frac{\partial H}{\partial u_i}, \quad (48)$$

where $i = 1, 2, 3$. The solution of $u_1^*(t)$, and $u_2^*(t)$ are presented in a compact form as

$$u_1^*(t) = \max \left\{ 0, \min \left\{ 1, \frac{\beta SI(\lambda_2 - \lambda_1)}{A_1} \right\} \right\}$$

and

$$u_2^* = \max \left\{ 0, \min \left\{ 1, \frac{p_2 IY(\lambda_3 - \lambda_2)}{(m+I)A_2} \right\} \right\}. \quad (49)$$

6. Numerical simulation

In order to verify the theoretical predictions of the model, we present some of the numerical simulations of the model as well as for optimal control analysis as follows:-

6.1. Numerical simulation of the model

In justification of the analytical solutions of the model, numerical simulations play a vital role in this aspect. In this section, the numerical simulations are carried out with respect to Rung-Kutta iteration of order four in conjunction with a set of reasonable parameter values given in Table 1. These parameter values are mainly hypothetical, but they are chosen following ecological observations.

Figure 1 shows the dynamics of individual populations varies with time. It is observed that the prey populations oscillate up and down with respect to time and decreases to its stability point. The sharp decrease in prey populations may be caused by predation rate and the disease acquired from infected prey through contact rate. The infected prey population suffers death due to the disease at a rate a_1 and since treatment is not offered to the infected prey population then, it stabilizes at endemic equilibrium point as shown in Figure 2(b). This requires further treatment to ensure that the disease dies out in the prey-predator system. Figure 2(c) shows the behavior of the predator population which increases or decreases as per predation effect especially infected prey which decreases the predator population. In Figure 2(d) we observe the interaction between infected and susceptible prey population, which decrease or increase with respect to increase or decrease of the other population. It's further observed that as the infected prey population decreases, the susceptible prey population slightly increases as the effect of predator predation. Figure 3(a) shows that as predator decreases lead to an increase of prey population which may be caused by less predation while 3(b) indicates that the increase in infected prey may decrease the predator population. Figure 4 describes how the predator interacts with susceptible and infected prey populations, whereby infected population tends to slow down the growth of other populations.

Table 1. Parameter value used in numerical simulation

Symbol	Value	Source
r	11.2	Mukhopadhyay et al. (2009)
k	500	Assumed
β	1.2	Mukhopadhyay et al. (2009)
p_1	0.4	Hugo et al. (2012)
p_2	0.8	Assumed
m	0.5	Hugo et al. (2012)
a_1	0.5	Mukhopadhyay et al. (2009)
e_1	0.01	Assumed
e_2	0.6	Assumed
q	0.25	Hugo et al. (2012)

The numerical simulations give the following Figures

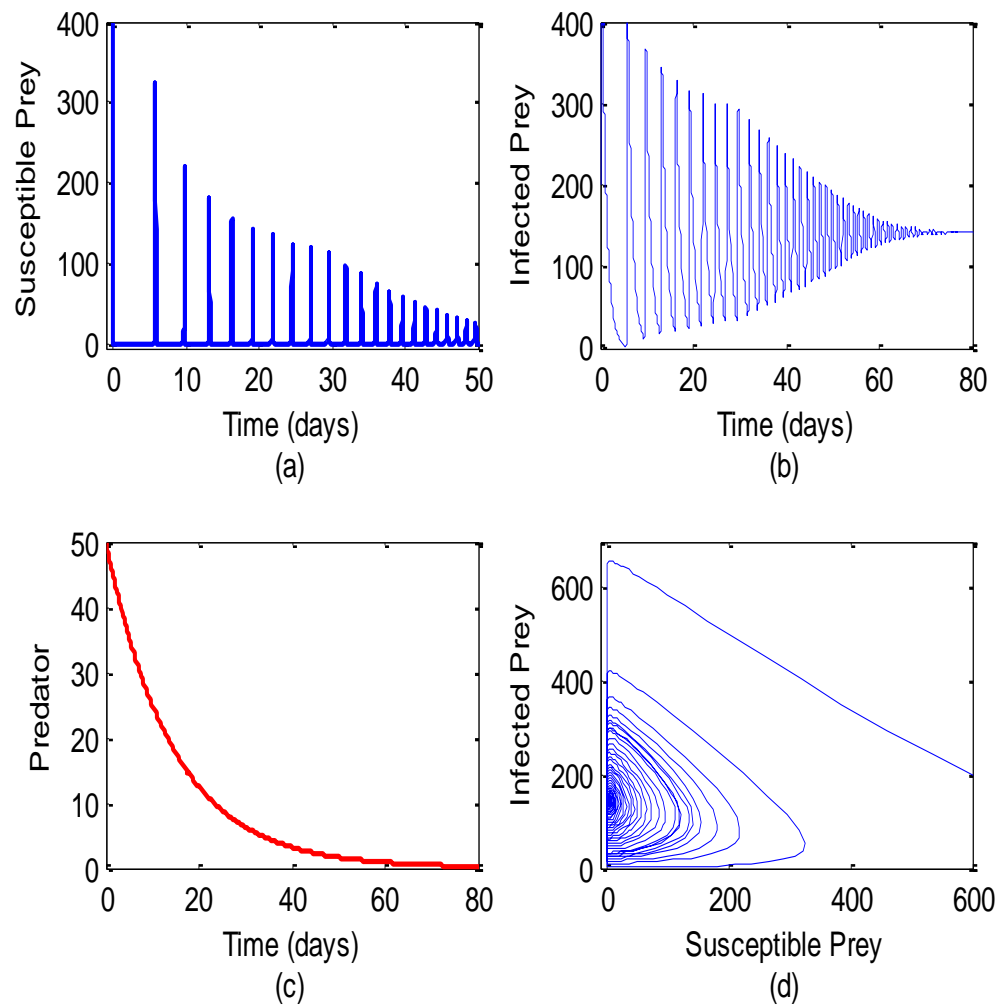

Figure 2. Prey predator populations' dynamics with parameter values in the table 1

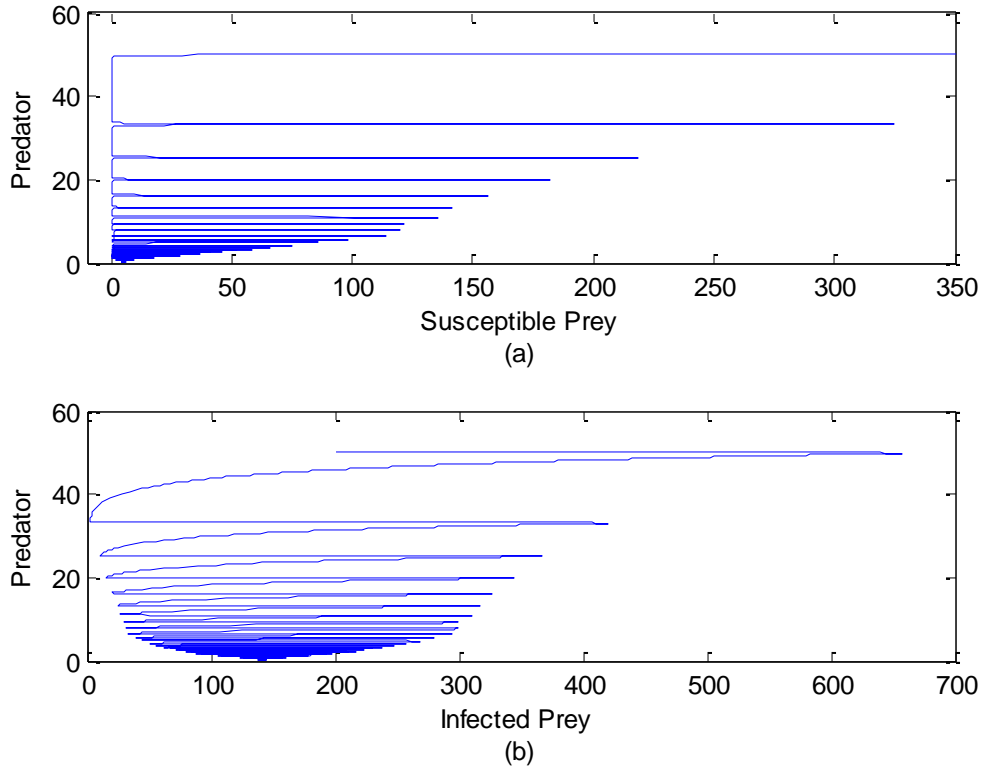

Figure 3. The effect of interaction between predator and prey populations

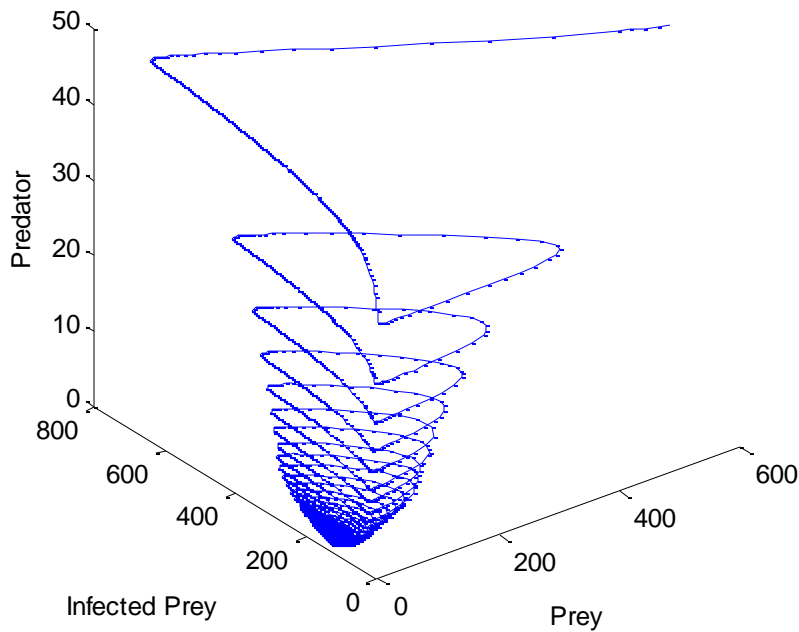

Figure 4. Variation of susceptible prey, infected prey and predator population

6.2. Numerical Simulation for Optimal Control Analysis

From the numerical simulations of the model, we observe that controlling disease in the population may require high cost as no any strategy that reflects what to control first. In subsection, we discuss three types of strategies that may be considered for the elimination of the disease in the population. These include the control rate by separation of infected and susceptible prey, the control rate by separating predator from infected prey and the combination of the two strategies. The results in some extent reflect with (Soovoojeet et al. (2016)) where they studied the influence of isolation of the infected individuals from susceptible one.

6.2.1. Control rate by separation of infected and susceptible prey

Figure 5 describes the comparison of the variation of the population with and without the control. It is significantly different in both prey and predator population which shows the importance of separating susceptible and infected prey populations, likewise through this separation predator enjoy health prey and definitely shows positive gain and hence, increase its growth rate.

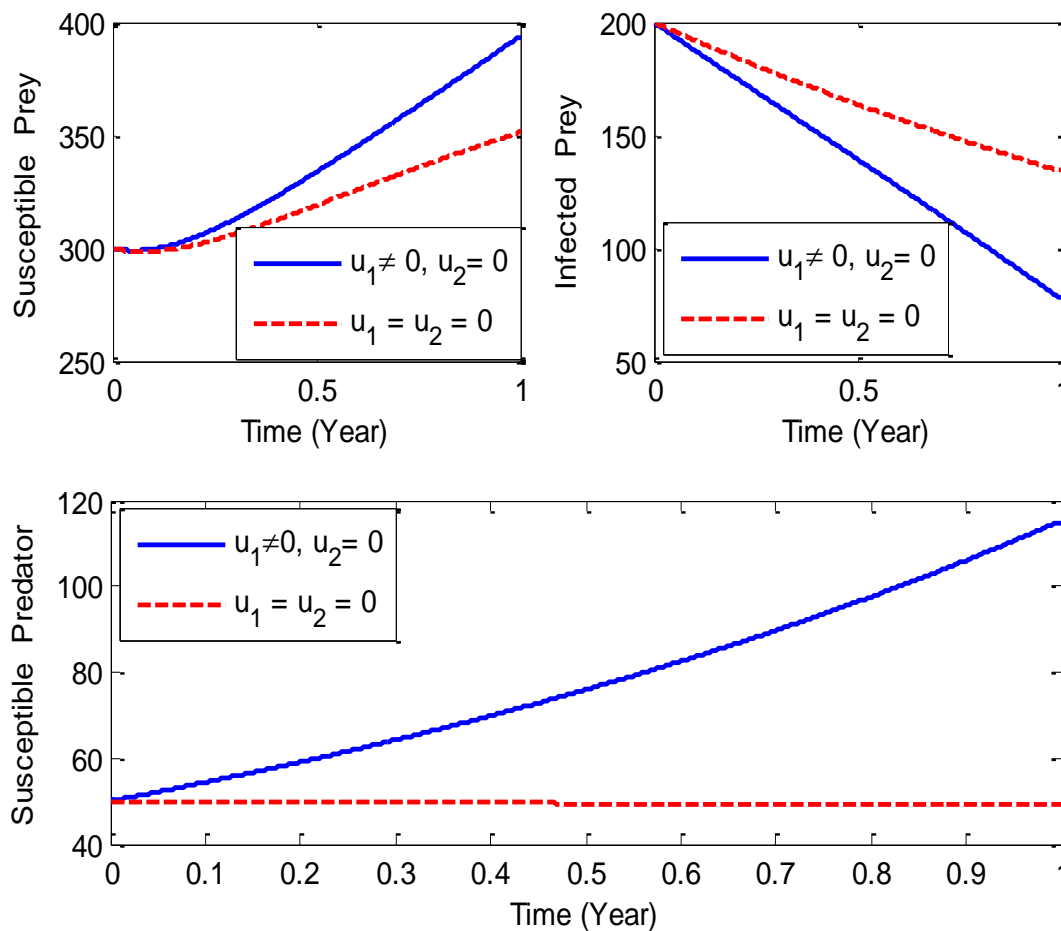

Figure 5. Variation of the population by separating susceptible prey from infected prey

6.2.2. Control rate by separating predator from infected prey

When a predator is separated from infected prey then, it will only depend on the health prey as the source of food and finally, the predator population expected to increase. Figure 6 shows these variations of populations as per infected prey separated from predation by a predator.

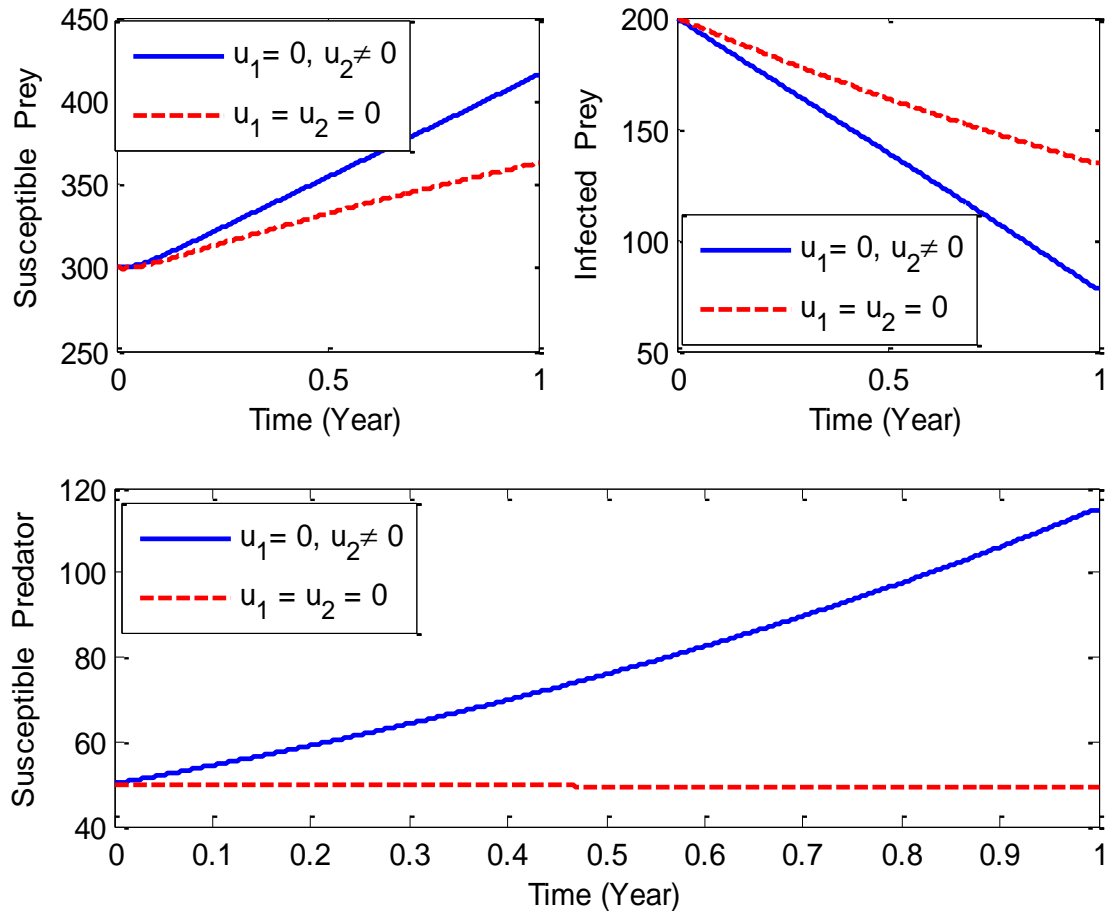

Figure 6. Variation of the population by separating prey and predator

6.2.3. Control rate by separation of infected from susceptible prey and predator populations

When the two populations are separated from infected prey, both populations grow rapidly as the effect of the absence of disease. Figure 7 describes the behaviors of populations as all control strategies applied.

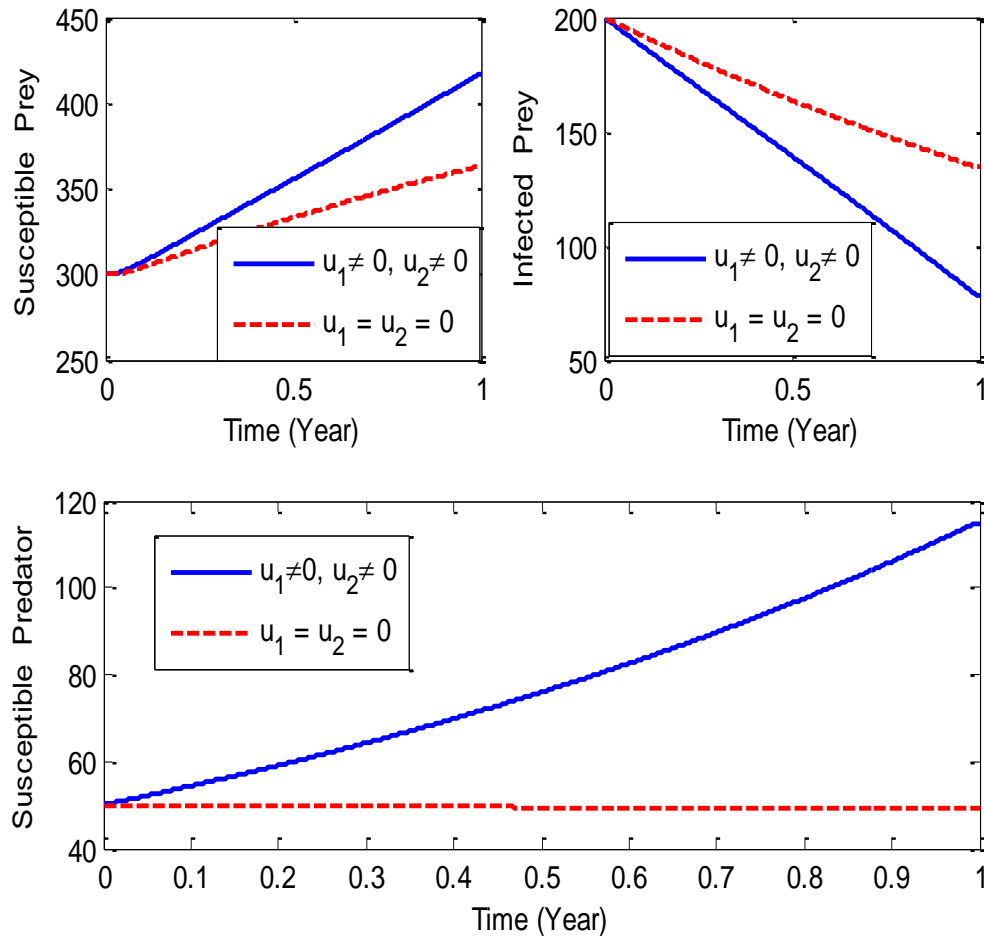

Figure 7. Variation of the population when susceptible prey and predator populations are separated from infected prey

7. Conclusion

This paper investigates the dynamics of an Eco-Epidemiological model. A deterministic model for the transmission dynamics of a disease in a Prey with the optimal control is designed and analyzed. Incorporating the optimal control for infected prey in the model provides more realistic and plays an important role in biological control for the spread of the disease. The boundedness and positivity hold which implies that the system is biologically well behaved as also obtained by (Hugo et al. (2012)). We obtain the equilibria of the model and its stability analysis was rigorously analyzed with the respective biological meaning conditions. Mathematically, our results stand upon the local stability of the disease-free equilibrium point (DFE) and the conditions for global stability which was determined using the Lyapunov function. Furthermore, the strategies for eliminating the disease in the prey-predator system were evaluated using Pontryagin's Maximum Principle (PMP) and the numerical results show that separation of infected prey into susceptible prey and predator saves more species. We further observed that as we increase the control rate of the infected prey tends to lower the disease in the population and hence, we recommend the infected population should be separated from susceptible to avoid the contaminations.

Acknowledgment:

The authors would like to thank the reviewers and Editor-in-Chief for their critical reviews, helpful suggestions and positive comments which helped to improve the paper.

REFERENCES

- Bornaa, C. S., Makinde, O. D. and Seini, I. Y. (2015). Eco-epidemiology model and Optimal Control of disease transmission between humans and animals. *Communications in Mathematical Biology and Neuroscience*, Vol.8, No. 2, pp. 1–28.
- Chaity, Ganguli and Kar, T. K. (2017). Optimal Harvesting of a Prey- Predator Model with Variable Carrying Capacity, *International Journal of Biomathematics*, Vol. 10, No.5, pp. 24, World Science Publishing Company.
- Elettreby, M.F. and Aly, S. (2015). Optimal Control of a two teams Prey-Predator interaction model. *Miskolc Mathematical Notes*, Vol .16, No. 2, pp. 793–803.
- Gani, J. and Swift, R. J. (2013). Prey-Predator Models with Infected Prey and Predators, *Discrete and Continuous dynamical system*, Vol. 33, No. 11 and 12, pp. 5059-5066.
- Hethcote, H. W. (2000). The mathematics of infectious diseases. *SIAM Review*, Vol. 42, pp. 599–653.
- Hugo, A., Massawe, E.S. and Oluwole, D. M. (2012). An Eco-Epidemiological Mathematical Model with Treatment and Disease Infection in both Prey and Predator population, *Journal of Ecology and the Natural Environment*, Vol. 4, No.10, pp. 266-279.
- Jana, S. and Kar, T.K. (2013). Modeling and Analysis of a Prey-Predator system with the Disease in the Prey, *Nonlinear Science, and Nonequilibrium and Complex Phenomena, Chaos, Solutions and Fractals*, Vol.47, pp. 42-53.
- Jiao, J. J., Chen, L.S., Nieto, J.J. and Angela, T. (2008). Permanence and Global attractively of the Stage-structured Predator-prey Model with Continuous Harvesting on Predator and Impulsive stocking on Prey, *Applied Mathematics and Mechanics (English Edition)*, Vol. 29, No. 5, pp. 653-663.
- Kermack, W. O. and McKendrick, A. G. (1927). The Evolution of Virulence in Sterilizing Pathogens. *Pro-Royal Soc. London, A*, 115, pp. 700.
- Lenhart, Suzan. and Workman, J. T. (2007). *Optimal Control Applied to Biological Models*. CRC Mathematical and Computational Biology Series.
- Lotka, A. J. (1924). *Elements of Physical Biology* (Baltimore Williams and Wilkins Co., Inc).
- Massawe, L. N., Massawe, E. S, and Makinde, O. D. (2015). Modelling Infectiology and Optimal Control of Dengue Epidemic, *Applied and Computational Mathematics*, Vol . 4, No. 3, pp. 181–191.
- Mpeshe, S. C., Luboobi, L. S. and Nkansah-gyekye, Y. A. W. (2014). Optimal Control strategies for the dynamics of Rift Valey Fever. *Communications in Optimization Theory*, pp. 1–18.
- Mukhopadhyay, B. and Bhattacharyya, R. (2009). Role of predator switching in an eco-epidemiological model with disease in the prey, *Ecological Modeling*, Vol. 220, pp. 931–939, ELSEVIER.

- Okosun, K. O., Ouifki, R. and Marcus, N. (2011). Optimal control analysis of a malaria disease transmission model that includes treatment and vaccination with waning immunity. *BioSystems*, Vol. 106, pp. 136–145.
- Okosun, K., Makinde, O. D. and Takaidza, I. (2013). Impact of optimal control on the treatment of HIV / AIDS and screening of unaware infectives. *Applied Mathematical Modelling*, Vol. 37, No. 6, pp. 3802–3820.
- Pan, S. (2013). Asymptotic spreading in a Lotka-Volterra predator-prey system, *Journal of Mathematical Analysis and Applications*, Vol. 407, No.2, pp. 230-236.
- Raid, Kamel N. and Kawa, Ahmed H. (2012). The dynamics of the prey-predator model with disease in prey, *Math Comput. sci.* Vol. 2, No. 4, pp. 1052-1072, ISSN: 1927-5307.
- Sontag, E. (1998). *Mathematical Control Theory*. Springer (2nd). Springer. http://doi.org/10.1007/978-3-540-69532-5_16.
- Soovoojeet, Jana., Palash, Haldar and Kar, T. K. (2016). Mathematical Analysis of an Epidemic Model with isolation and Optimal Controls, *International Journal of Computer Mathematics*, DOI: 10.1080/00207160.2016.1190009.
- Tchuenche, J. M., Khamis, S. A., Augusto, F. B. and Mpeshe, S. C. (2011). Optimal Control and Sensitivity Analysis of an Influenza Model with Treatment and Vaccination. *Acta Biotheoretica*, Vol. 59, No. 1, pp. 1–28.
- Tengaa, P., Makinde, O. D. and Massawe, E. S. (2015). An Eco-Epidemiological Model with Nonlinear Incidence and Infective Prey Treatment Class. *International Journal of Modern Trends in Engineering and Research*, pp. 308–329.
- Zhou, J. and Shi, J. (2013). The existence, Bifurcation and Stability of positive stationary solutions of a diffusive Leslie-Gower predator-prey model with Holling-type II functional responses, *Journal of Mathematical Analysis and Applications*, Vol. 405, No.2, pp. 618-630.