



5-2016

Performance Analysis of Solar Adsorption Cooling System - Effect of Position of Heat Storage Tank

Rifat A. Rouf
Independent University, Bangladesh

K. C. Amanul Alam
East-West University, Bangladesh

M. A. Hakim Khan
Bangladesh University of Engineering and Technology

Bidyut B. Saha
Kyushu University

Ibrahim I. El-Sharkawy
Mansoura University

Follow this and additional works at: <https://digitalcommons.pvamu.edu/aam>

 Part of the [Ordinary Differential Equations and Applied Dynamics Commons](#), and the [Partial Differential Equations Commons](#)

Recommended Citation

Rouf, Rifat A.; Amanul Alam, K. C.; Hakim Khan, M. A.; Saha, Bidyut B.; and El-Sharkawy, Ibrahim I. (2016). Performance Analysis of Solar Adsorption Cooling System - Effect of Position of Heat Storage Tank, *Applications and Applied Mathematics: An International Journal (AAM)*, Vol. 11, Iss. 3, Article 5. Available at: <https://digitalcommons.pvamu.edu/aam/vol11/iss3/5>

This Article is brought to you for free and open access by Digital Commons @PVAMU. It has been accepted for inclusion in *Applications and Applied Mathematics: An International Journal (AAM)* by an authorized editor of Digital Commons @PVAMU. For more information, please contact hvkoshy@pvamu.edu.



Available at
<http://pvamu.edu/aam>
Appl. Appl. Math.
ISSN: 1932-9466

**Applications and
Applied Mathematics:**
An International Journal
(AAM)

Special Issue No. 2 (May 2016), pp. 52 – 68

18th International Mathematics Conference, March 20 – 22, 2014, IUB Campus, Bashundhara
Dhaka, Bangladesh

Performance Analysis of Solar Adsorption Cooling System - Effect of Position of Heat Storage Tank

**Rifat A. Rouf¹, K. C. Amanul Alam², M. A. Hakim Khan³,
Bidyut Baran Saha⁴ and Ibrahim I. El-Sharkawy⁵**

¹Department of Physical Sciences
School of Engineering and Computer Sciences
Independent university, Bangladesh
rifat_rouf@yahoo.com

²Department of Electronics and Communication Engineering
East-West University, Dhaka, Bangladesh

³Department of Mathematics, Bangladesh University of Engineering and Technology
Dhaka, Bangladesh

⁴Mechanical Engineering Department, Kyushu University
International Institute for Carbon-Neutral Energy Research (WPI-I2CNER)
Kyushu University, 744 Motooka, Nishi-ku, Fukuoka-shi, Fukuoka 819-0395, Japan

⁵Mechanical Power Engineering Department
Faculty of Engineering, Mansoura University, El-Mansoura 35516, Egypt
Faculty of Engineering Sciences, Kyushu University, Kasuga-koen 6-1, Kasuga-shi, Fukuoka 816-8580, Japan
International Institute for Carbon-Neutral Energy Research (WPI-I2CNER), Kyushu University
744 Motooka, Fukuoka 819-0395, Japan

ABSTRACT

An insulated storage tank has been added with adsorption cooling system run by solar heat collected by CPC panel. It has been expected and seen that the storage tank has a vital contribution in the performance of the chiller. The storage tank is connected with a solar heat driven single stage two bed basic adsorption chillers activated with silica gel-water pair in two ways. The tank is connected in such a way that (i) the solar collectors supply hot water to the desorption bed, the outflow of the desorber is collected in the reserve tank. The reserve tank supplies water to the collector and complete the heat transfer cycle. (ii) The solar collector supply hot water which is collected in the storage tank first and then supplied to the desorber. The outflow of the desorber is carried to the collector again. Comparative studies have been conducted at the steady state for both of the systems with heat storage. It has been observed that the system is robust with design (i) while with design (ii) performance enhances beyond the sunset time with heat storage.

KEYWORDS: Numerical simulation; Heat transfer; Mass transfer; Solar heat; Adsorption cooling; Reserve tank; Renewable energy

MSC (2010) No.: 34K28, 35K05

1. INTRODUCTION

At present, in the field of energy systems the study in various energy conversion systems mainly heat pumps, sorption systems, energy conversion and storage devices are in the top priority. Adsorption refrigeration and air conditioning cycles have earned considerable attention due to its ability to utilize low temperature heat source and for the environmental aspects as it uses environment friendly refrigerants. The advantage and development of adsorption cycle have been widely studied by Meunier (1998). Later, researchers have made development to adsorption technology. In this respect, some have considered the improvement of the COP values while the others focused on the system cooling capacity. Advanced cascaded cycle (1986), thermal wave cycles by Shelton (1990) have been introduced for the enhancement of COP values. While mass recovery cycle by Wang (2001) and Akahira (2005) is for improvement of system cooling capacity. Advanced multiple-bed system Chua (2001), such as three-stage by Saha (1995) and two-stage Saha (2000) cycles could be effective for utilization of low temperature heat source. In recent times Hamdy et al. (2015), Wirajati et al. (2015) and many more have published their work.

Adsorption technology with solar coupling could be one of the attractive and alternative energy source to produce necessary cooling instead of conventional energy source. Yang and Sumanthy (2004) first exploited the lumped parameter model for two beds adsorption cycle driven by solar heat. Later, Clause et al. (2008) investigated the performances of a small adsorption unit for residential air conditioning in summer and heating during the winter period for the climatic condition of Orly, France. And Zhang et al. (2011) investigated the operating characteristics of silica gel-water pair as adsorbent/ adsorbate utilizing solar powered adsorption cooling system. Recently Alam et al. (2013) investigated the performances of solar collector driven adsorption cooling system under the climatic condition of Tokyo, Japan. A similar study has been carried out by Rouf et al. (2013) for the climatic condition of Dhaka, Bangladesh. Later, effect of the operating conditions for a two bed basic adsorption cycle with silica gel-water pair powered by solar heat has been investigated (2013). Recently, Alam et al. (2016) introduced adsorption chiller driven by storage heat collected from solar radiation.

In the present study the performance of a two bed adsorption cooling system which is run by solar heat, with silica gel-water pair as adsorbent/ adsorbate, is analyzed mathematically for two cases under the climatic condition of Dhaka. The place is located in the northern hemisphere at $23^{\circ}46'N$ (latitude), and $90^{\circ}23'E$ (longitude). Investigation is done on the performance of the chiller with two different designs considered to attach heat storage with solar heat driven basic adsorption chiller. For both cases, the heat is reserved in a storage tank, then the storage heat is used to drive the adsorption chiller. A comparative study has been conducted for both of the designs for attachment of the storage tank.

2. SYSTEM DESCRIPTION

A series of solar panel is connected with conventional single stage two-bed basic adsorption cycle. A storage tank, holding water, is connected with the solar panel and alternately to the two

adsorption beds (SE1 and SE2). Two different designs have been considered to attach the storage tank to the solar adsorption chiller. Schematic diagram of adsorption solar cooling system with storage tank according to the first and second design are given in Figure 1 (a) and (b) respectively. The desorber/adsorber heat exchangers (SE2/ SE1, Figure 1) are alternately connected, to the hot water chain and condenser during the pre-heating and desorption/condensation processes, and to the cooling tower and evaporator during the pre-cooling and adsorption/evaporation processes respectively. According to the first design, the heat transfer fluid (water) is heated in the solar collector and transported to the desorber. Desorber gains heat and the outflow of this hot water from the desorber then collected in the storage tank. Storage tank supplies water to the collector where it gains heat and complete the cycle. While according to design 2, the collector supplies heat through the heat transfer fluid (water) to the reserve tank. Reserve tank then supplies water to the desorber. Desorber gains heat and outflow of the desorber is supplied to the collector again. The hot water supply chain during both design 1 and 2 is discussed in table 1. And reserve tank specification is given in table 2.

The principle of basic adsorption cycle is available in literature, Saha et al. (1995). The chiller configuration is same as Alam et al. (2013). Here silica gel-water pair has been utilized as adsorbent/adsorbate pair. The chiller configurations are presented in table 3. Solar collector panels are utilized as heat source for the chiller. The two adsorbent beds are connected with the hot water chain and condenser and with cooling tower and evaporator alternately. There are two half cycles in each cycle. Such that during first half cycle, namely mode a) the heat exchanger SE1 is connected with the cooling tower as well as the evaporator and at the same time heat exchanger SE2 is connected with the hot water chain as well as the condenser. During the second half cycle, mode b) the heat exchanger SE1 is connected with the hot water chain as well as the condenser and at the same time heat exchanger SE2 is connected with the cooling tower as well as the evaporator.

There are four thermodynamic steps in each mode, namely (i) precooling, (ii) adsorption/evaporation, (iii) preheating and (iv) desorption/condensation. Schematic of mode a) of solar heat driven adsorption chiller with storage tank design 1 is presented in Figure 1 (a) and design 2 is presented in Figure 1 (b). The heat transfer fluid (water) is heated in the solar collector and transported to the desorber (design 1). Desorber gains heat and the outflow of this hot water from the desorber then it is transported to the storage tank. Storage tank supplies water (from its lower level) to collector again. But in case of design 2, hot collector outlet is transported to the reserve tank first then tank supplies water to the desorber from its upper level. The outflow of the desorber is then supplied to the collector again. At the same time cooling water is supplied from the cooling tower to the adsorber and condenser. During the pre-cooling mode adsorber (SE1) loses temperature while the desorber (SE2) is in preheating mode and gains heat. As soon as the pressure of the adsorber (SE1) reduces and is equivalent to the pressure of the evaporator, the valve V9 between the adsorber and evaporator is open and the adsorption and evaporation mode starts. On the other hand, as the temperature rise (during the preheating mode) the desorber starts desorption and the pressure inside the bed increases. As the pressure of the desorber and the condenser is equivalent, the valve V6 between the two is open and refrigerant vapor (water vapor) is transported to the condenser where it will be condensed and entered into the evaporator. As soon as the adsorption/desorption mode is over a half cycle is completed and the system starts its' second half cycle with SE1 at its preheating mode and SE2 at its pre-cooling mode and the system repeats.

3. MATHEMATICAL FORMULATION

The pressure temperature and concentration in each heat transfer unit is considered to be uniform. Based on these assumptions a lumped parameter model has been exploited to calculate energy balance of all heat transfer units. Each collector has nine pipes, water enters through the first pipe and the outlet of the first pipe enters into the next pipe thus the outlet of the ninth pipe of each collector combines together and enters into the desorber. Hence, the temperature of the heat transfer fluid in each pipe is calculated separately for all the collectors.

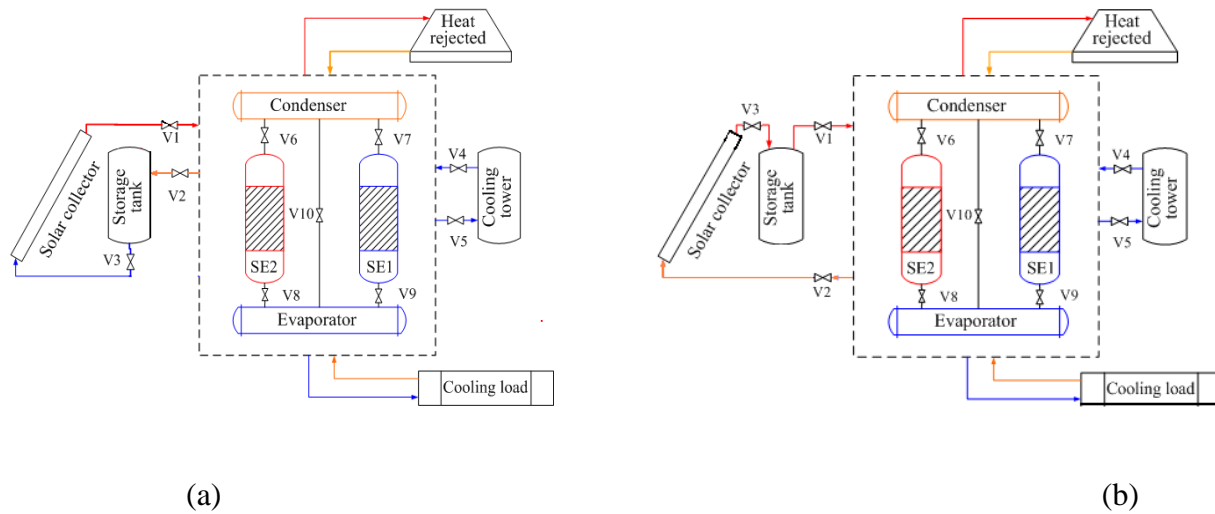

Figure 1. Schematic diagram of solar heat driven adsorption cooling system (a) design 1 and (b) design 2

Table 1. Design of the solar adsorption cooling system with storage tank

Design 1	Collector->	Desorber->	Storage tank->	Collector
Design 2	Collector->	Storage tank->	Desorber->	Collector

Table 2. Design of reserve tank

Symbol	Description	Value
LHW	Dimension of the tank	1.3 m
W_{tv}	Volume of the tank	1.3^3 m^3
W_{wt}	Weight of water in reserve tank	$W_{tv} \times 1000 - 10 \text{ kg}$
U_{tloss}	Reserve tank heat transfer loss coefficient	$0.5 \text{ W/m}^2\text{K}$
AS_{rt}	Reserve tank outer surface area	$6 \times 1.3^2 \text{ m}^2$
W_{tm}	Reserve tank metal weight	$A_{wt} \times 0.005 \times 2700 \text{ kg}$

Table 3. Design and the operating conditions used in the simulation

Symbol	Description	Value
A_{bed}	Adsorbent bed heat transfer area	2.46 m ²
A_{con}	Condenser heat transfer area	3.73 m ²
A_{cr}	Each collector area	2.415 m ²
A_{eva}	Evaporator heat transfer area	1.91 m ²
$C_{p,M(Al)}$	Specific heat of aluminum (Al)	905 J/kg.K
$C_{p,M(Cu)}$	Specific heat of copper (Cu)	386 J/kg.K
$C_{p,si}$	Specific heat of silica gel	924 J/kg.K
$C_{p,w,l}$	Specific heat of water (liquid phase)	4.18E+03 J/kg.K
$C_{p,w,v}$	Specific heat of water (vapor phase)	1.89E+03 J/kg.K
D_{s0}	Diffusion coefficient	2.54E-04 m ² /s
Ea	Activation energy	2.33E+06 J/kg
i	Number of pipe in each collector	9
L	Latent heat of vaporization (water)	2.6E+06 J/kg
$\dot{m}_{f,cool}$	Cooling water flow rate to adsorber	1.3 kg/s
$\dot{m}_{f,con}$	Cold water flow rate to condenser	1.3 kg/s
$\dot{m}_{f,hot}$	Total mass flow rate to CPC panel or to desorber	1.3 kg/s
Q_{st}	Heat of adsorption (silica gel bed)	2.81E+06 J/kg
R	Water gas constant	4.62E+02 J/kg.K
R_p	Particle diameter (Silica gel)	0.35E-03m
U_{bed}	Heat transfer coefficient of each bed	1724.14 W/m ² K
U_{con}	Condenser heat transfer coefficient	4115.23 W/m ² K
U_{eva}	Evaporator heat transfer coefficient	2557.54 W/m ² K
$W_{con,w}$	Condenser refrigerant (water) inside condenser	0.0 kg
$W_{eva,w}$	Liquid refrigerant (water) inside evaporator initially	50 kg
W_{si}	Weight of silica gel in each bed	47 kg

The energy balance of each collector can be expressed as:

$$W_{cp,i} \frac{dT_{cr,i}}{dt} = \gamma \left\{ \eta_i A_{cr,i} I + \dot{m}_{f,cr} C_f (T_{cr,i,in} - T_{cr,i,out}) \right\} + (1-\gamma) U_{loss} A_{cr,i} (T_{am} - T_{cr,i}) \quad (1)$$

$$T_{cr,i,out} = T_{cr,i} + (T_{cr,i,in} - T_{cr,i}) \text{EXP}(U_{cp,i} A_{cp,i} / \dot{m}_{f,cr} C_f), \quad (2)$$

where, $i = 1, \dots, 9$ and γ is either 1 or 0 depending on daytime or nighttime.

The energy balance for the reserve tank can be expressed as:

$$\frac{d}{dt} \left\{ (W_{tm} C_{tm} + W_{wt} C_w) T_{wt} \right\} = \dot{m}_w C_w (T_{bed,out} - T_{wt}) + U_{loss} A_{rt} (T_{am} - T_{wt}), \quad (3)$$

$$T_{cr,i,out} = T_{cr,i+1,in}, \quad T_{cr,9,out} = T_{bed,in} \quad \text{and} \quad T_{bed,out} = T_{wt,in} \quad (4)$$

in case of design 1.

Although for design 2, the energy balance for the reserve tank can be expressed as:

$$\frac{d}{dt} \left\{ (W_{tm} C_{tm} + W_{wt} C_w) T_{wt} \right\} = \dot{m}_w C_w (T_{wt} - T_{bed,in}) + Ut_{loss} AS_{rt} (T_{am} - T_{wt}), \quad (5)$$

$$T_{cr,i,out} = T_{cr,i+1,in}, \quad T_{cr,9,out} = T_{wt,in}, \quad T_{bed,in} = T_{wt} \quad \text{and} \quad T_{bed,out} = T_{cr,in}. \quad (6)$$

The energy balance in each bed is calculated as:

$$\frac{d}{dt} \left\{ (W_M C_{b,M} + W_{si} C_{si} + W_{si} q_d C_{p,w}) T_b \right\} = Q_{si} M_{si} \frac{dq_d}{dt} + \dot{m}_f C_{p,f} (T_{f,out} - T_{f,in}) + \partial MC_{si} C_{pv,w} \frac{dq_a}{dt} (T_{ev} - T_b), \quad (7)$$

where, ∂ is 0 or 1 based on the sorption bed working as desorber or adsorber.

Based on the same assumptions the energy balance for the condenser is;

$$\frac{d}{dt} \left\{ (MC_{cd,M} + MC_{CW}) T_{cd} \right\} = -L \cdot M_{si} \frac{dq_d}{dt} + M_{si} C_{pv,w} \frac{dq_d}{dt} (T_{cd} - T_d) + \dot{m}_{cd,w} C_{p,cd,w} (T_{w,cd,in} - T_{w,cd,out}), \quad (8)$$

and that of the evaporator is similarly

$$\frac{d}{dt} \left\{ (MC_{e,M} + MC_{e,w}) T_e \right\} = -L \cdot M_{si} \frac{dq_a}{dt} + M_{si} C_{pl,w} \frac{dq_d}{dt} (T_e - T_{cd}) + \dot{m}_{Chill} C_{p,Chill} (T_{Chill,in} - T_{Chill,out}) \quad (9)$$

The outlet temperature of the different water loops is;

$$T_{out} = T + (T_{in} - T) \cdot \exp(-UA / \dot{m} C_p) \quad (10)$$

The adsorption rate for silica gel-water is dependent on a nonlinear function $k_s a_p$ and of difference between concentration of equilibrium state q^* and that of the present state q :

$$\frac{dq}{dt} = \psi(q^*, q) = k_s a_p (q^* - q), \quad (11)$$

where, the overall mass transfer coefficient function is $k_s a_p$ dependent on adsorbent (silica gel) surface diffusivity D_s and particle diameter R_p ;

$$k_s a_p = (15D_s) / (R_p)^2. \quad (12)$$

However, the surface diffusivity D_{s0} is dependent on diffusion coefficient of the adsorbent E_a and activation energy;

$$D_s = D_{s0} \exp(-E_a / RT), \quad (13)$$

q^* = equilibrium concentration at temperature T which is calculated by;

$$q^* = B \left(\frac{P_s(T)}{P_s(T_B)} \right)^A. \quad (14)$$

This is known as modified Freundlich equation, to provide a concise analytical expression of experimental data.

Here, $B = b_0 + b_1T + b_2T^2 + b_3T^3$ and $A = a_0 + a_1T + a_2T^2 + a_3T^3$. The saturation pressure is calculated according to the Antoine's equation, where the experimental values of coefficients a_i 's and b_i 's are given in table 4. The saturation pressure of water is calculated by;

$$P_s(T) = 1.33.32e^{[18.3-3820/(T-46.1)]}. \quad (15)$$

The cooling capacity is calculated by the equation:

$$CACC = \dot{m}_{chill} C_w \int_0^{t_{cycle}} (T_{chill,in} - T_{chill,out}) dt / t_{cycle}. \quad (16)$$

The cycle COP (coefficient of performance) and solar COP in a cycle (COP_{sc}) are calculated respectively by the equations:

$$COP_{cycle} = \frac{\int_{beginofcyclertime}^{endofcyclertime} \dot{m}_{CW} C_{P,CW} (T_{CW,in} - T_{CW,out}) dt}{\int_{beginofcyclertime}^{endofcyclertime} \dot{m}_{HW} C_{P,HW} (T_{HW,out} - T_{HW,in}) dt}, \quad (17)$$

$$COP_{sc} = \frac{\int_{beginofcyclertime}^{endofcyclertime} \dot{m}_{CW} C_{P,CW} (T_{CW,in} - T_{CW,out}) dt}{\int_{beginofcyclertime}^{endofcyclertime} n \cdot A_{cr} I dt}. \quad (18)$$

In equation (18), I is the solar irradiance, A_{cr} is each collector area and n is the number of collector.

The $COP_{solar.net}$ is calculated as;

$$COP_{solar.net} = \frac{\int_{Sunrisetime}^{chillerstopptime} \dot{m}_{chill} C_{chill} (T_{chill,in} - T_{chill,out}) dt}{\int_{Sunrisetime}^{sunsettime} n \cdot A_{cr} I dt}. \quad (19)$$

4. SIMULATION PROCEDURE

Measured average of average monthly maximum radiation data of seven years (2003-2010) for Dhaka (Latitude 23°46'N, Longitude 90°23'E) has been used. This data is supported by the Renewable Energy Research Center (RERC), University of Dhaka. Results are generated based

on solar data of Dhaka on the month of April. Chiller configurations and collector data are same as Alam et al. (2016). During April in Dhaka, the sunrise time is 5.5h and sun sets at 18.5h, whereas maximum temperature is 34°C and minimum temperature is 24°C. The maximum solar radiation, in this month is about 771 W/m². The input data are given in table 3.

The set of differential equations (1) to (10) has been solved by implicit finite difference approximation method. The water vapor concentration in a bed is represented in Equation (11). Where, the concentration q is a nonlinear function of pressure and temperature. It is almost unfeasible to divide the concentration in terms of temperature for the present time and previous time. Hence, to begin with, the temperature for present step (beginning of the first day) is based on assumption. The pressure and concentration is then calculated for the present step based on this assumption of temperature. Later, gradually the consequent steps are calculated based on the primary concentration with the help of the finite difference approximation. During this process, the newly calculated temperature is checked with the assumed temperature if the difference is not less than convergence criteria, then a new assumption is made. Once the convergence criteria are fulfilled, the process goes on for the next time step. The cycle is in unstable conditions in the beginning; however, it reaches its cyclic steady state conditions after few cycles. Therefore the program is allowed to run from the transient to cyclic steady state. The tolerance for all the convergence criteria is 10^{-4} .

The equations for desorber, collector and reserve tank are completely dependent on each other. Therefore, those equations are discretized by the finite difference approximations which form a set of linear equations in terms of temperature and their outlets. A Gaussian elimination method is exploited to solve the system of linear equations. In the beginning all initial conditions are set on ambient temperature, however, concentrations have been taken slightly less than its saturation conditions which allow the program run steadily. The solar data and ambient temperature are taken for Dhaka (Bangladesh) in April. The ambient temperature is calculated using the following equation:

$$T_{am} = (T_{max} + T_{min})/2 + \frac{T_{max} - T_{min}}{2} * \sin\left(\frac{\pi * (Daytime - Sunrise - i)}{Daylength}\right) \quad (20)$$

Table 4. Numerical values of the coefficients a_i 's and b_i 's

coefficients	value	coefficients	value
a_0	-15.587	b_0	-6.5314
a_1	0.15915	b_1	0.72452E-01
a_2	-0.50612E-03	b_2	-0.23951E-03
a_3	0.53290E-06	b_3	0.25493E-06

where, i equals to the time difference between the maximum radiation and maximum temperature of the day.

5. RESULT AND DISCUSSION

First the driving source temperature has been checked for both design 1 and 2 with different collector number and cycle time. The driving temperature of the adsorption cooling system with silica gel – water pair is around 80°C. For the climatic condition of Dhaka, Bangladesh, 14 collectors each of area 2.415 m² with cycle time 1000s is enough to raise sufficient bed temperature to run the silica gel-water adsorption cooling system with direct coupling of solar collector (Rouf et al. (2013)) for the base run conditions. However, the present system needs to first heat up the water of the reserve tank and then the collector is able to provide the system enough temperature to run the cooling unit. Therefore it is observed that it needs more collectors to heat up the bed than that of adsorption cooling system with direct solar coupling. Hence, 20, 22, 24, 26, 28 and 30 no of collectors have been considered for the present case to investigate the optimum system performance.

The temperature histories of collector outlet, bed and reserve tank for different number of collectors and cycle times to begin with have been studied. The system comes to its' steady state from day 2 for both of design 1 and 2. The temperature histories of collector outlet, adsorption beds and tank water for few consecutive days are presented in Figure 2 (a) and (b) as an example. Since in design 1 heat transfer fluid (water) is supplied to the collector from tank, therefore there remains an inflow of constant temperature to the collector. On the other hand, in design 2, collector in flow comes from the outlet of the desorber. Hence after every half cycle there remains a temperature drop in collector in flow. As a result, in Figure 2 (b) a fluctuation is observed in collector outlet. Temperature history of collector outlet two beds and tank water are illustrated in Figure 3 (a), (b) of both system designs. It needs at least 30 collectors with cycle time 1400s to obtain required amount of driving temperature for tank dimension 1.3 m. However, if the dimension decreases it needs a less no of collectors to heat up tank water and activate the chiller. Otherwise it is also observed that the driving temperature rises beyond 100°C with higher cycle time; however, it may produce high pressure on the copper tube which carries heat supply to the heat transfer units and also affect the system performance. It can also be noted that the bed temperature fluctuate in the beginning of the day. It happens due to the initial concentration. At the beginning, both beds are assumed saturated with water vapor at ambient temperature, therefore, both beds desorb vapor in the beginning. However, after few cycles, the system reaches its cyclic steady conditions. Therefore, performances of the system after few cycles do not have any effect on initial conditions.

In order to come to the steady state, the system is allowed to run for few consecutive days. With 1400s cycle time the system comes to its steady state from the second day. The chiller works till the temperature difference between the heat source (heat input) and heat sink (ambient temperature) is 25°C. The collector, adsorption / desorption beds and all other units of the chiller exchange heat with the outer environment during night time and loses temperature and come to the ambient temperature in the next morning. The storage tank is insulated hence the tank water temperature is higher than the ambient temperature at the beginning of the second day. At 5.5h the valve between the storage tank and the collector is reopened. Hot water from the storage tank travels through the collector and the bed, loses temperature, returns to the tank. Thus, when all the heat exchangers gain the driving temperature, the chiller starts working at 8.0 h in the morning since it does not need to heat up the tank water this time.

The collector temperature reaches to 89.45°C while the bed temperature is 89.22°C when cycle time is 1400s at the steady state with design 1. Meanwhile, for design 2 collector temperature reaches to 92.38°C and hence bed temperature is 88.74°C with cycle time 1400s. The temperature histories of the collector, adsorption /desorption beds and tank at peak hours steady state have been presented in Figure 3 (a) and (b).

At the steady state, temperature of the tank water is higher than the ambient temperature and is supplied to the collector. It increases the temperature of the collector and the desorber. The outlet of the desorber returns to the tank. The temperature of the outlet of the desorber is lower than that of the tank water. For some time in the morning when enough radiation is not available, the tank water loses temperature. This behavior is visible in Figure 3. Which indicate that according to design 1 the chiller is capable to utilize maximum heat absorbed by solar collector. On the other hand according to design 2 the collector temperature rises higher but the bed temperature is less than that of design 1.

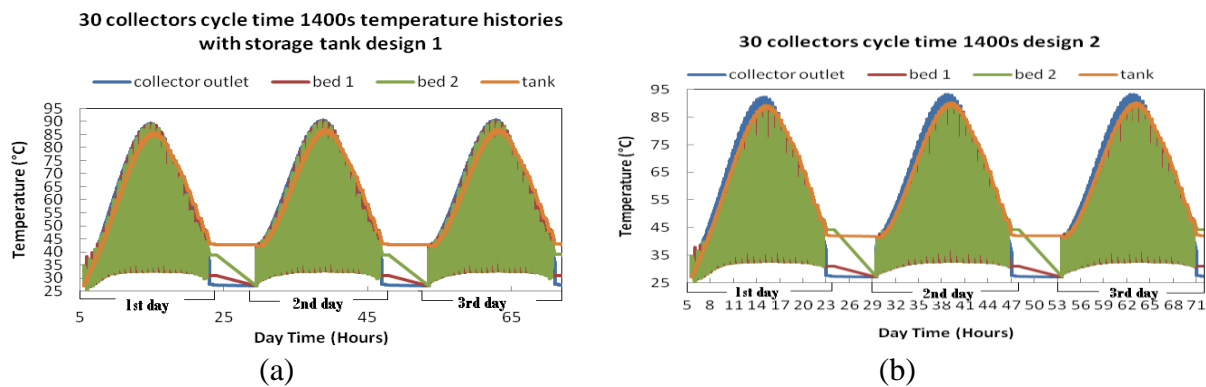

Figure 2. Temperature history of heat transfer units for few consecutive days (a) storage tank design 1 and (b) storage tank design 2

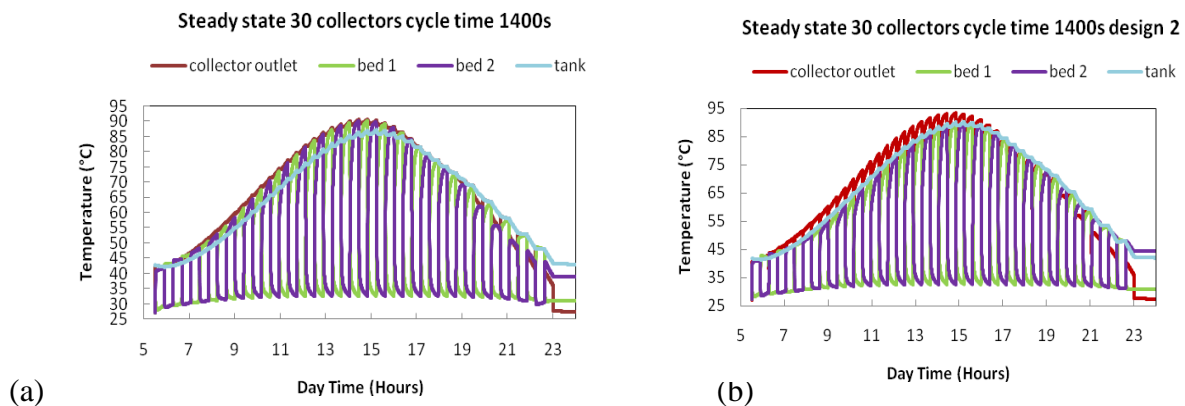

Figure 3. Temperature history of heat transfer units at steady state (a) storage tank design 1 and (b) storage tank design 2

The performance of the chiller with both design 1 and 2 are depicted in Figure 4 (a) to (f). The optimum collector area is 30 with optimum cycle time 1400s. Maximum cooling capacity is 9.3 kW for design 1 while it is 9.28 for design 2. The chiller starts working at least 20 minutes later than design 1. Optimum COP cycle at the peak hours is 0.5 and maximum COP cycle occurs after sunset and it is 0.68 for optimum collector area and cycle time in case of design 1. On the other hand in case of design 2 COP cycle is 0.5 at the peak hours and maximum value occurs after sunset and it is 0.75. Also for both design net COP solar is 0.23. Hence a comparative Figure for the performance of both design I and 2 is presented in Figure 5 (a), (b) and (c). The performance of the chiller for design 2 starts at least 20 minutes late than that of design 1.

The cooling effect to the end user depends on the evaporator outlet. The evaporator outlet temperature at the peak hours of the steady state, that is 15 to 20 h of the third day, is 7.5° for design 1 and it is 7.6° for design 2. According to design 1 the reserve tank is positioned before the collector. During day time collector temperature rises very quickly hence the temperature of the desorber can be raised within a short time and the system becomes robust. A comparative figure of the evaporator outlet of design 1 and design 2 at the steady state at peak hours is illustrated in Figure 6.

Due to the position of the tank, the efficiency of the collector has been calculated. It is seen that for design 1, overall collector efficiency is 0.68 at the steady state. However, the efficiency gradually decreases after 15.0 h. The efficiency of the collector η_{sc} is calculated according to the manufacturer's data, same as Clause et al. (2008), that is,

$$\eta_{sc} = 0.75 - 2.57 * \left(\frac{\bar{T}_{HW} - T_{am}}{I} \right) - 4.67 * \left(\frac{\bar{T}_{HW} - T_{am}}{I} \right)^2, \quad (21)$$

where, \bar{T}_{HW} is the heat transfer fluid mean temperature, i.e.,

$$\bar{T}_{HW} = \frac{T_{HW.in} + T_{HW.out}}{2} \quad (22)$$

and I is the solar radiation.

On the other hand, there exists fluctuation in the collector efficiency for design 2 (Figure 8 (b)). The reason behind this behavior can be explained with Figure 7. However, the overall collector efficiency is 0.68 for both of the designs although uniform efficiency is observed for design 1 while it oscillates for design 2. Since the collector outlet temperature for design 1 shows a uniform increase, during day time and decrease, at afternoon as a result there is uniform value in collector efficiency. On the other hand there exists fluctuation in the collector outlet temperature for design 2 hence there exist no uniformity in efficiency of the collector.

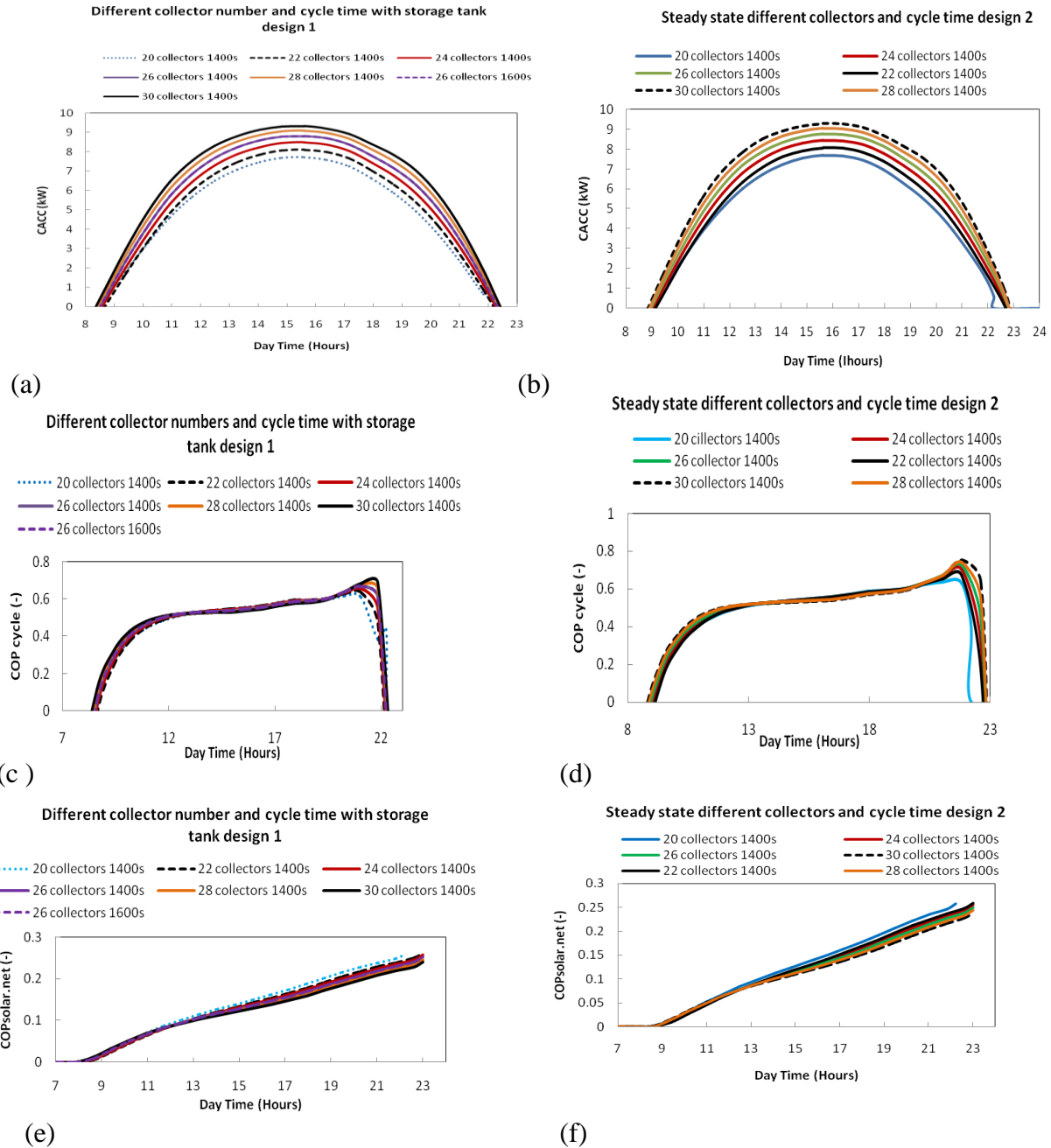

Figure 4. Performance of the adsorption chiller with different collector area and different cycle time for reserve tank design 1 & 2 (a) CACC design 1, (b) CACC design 2, (c) COP cycle design 1, (d) COP cycle design 2, (e) COP solar.net design 1 and (f) COP solar.net design 2

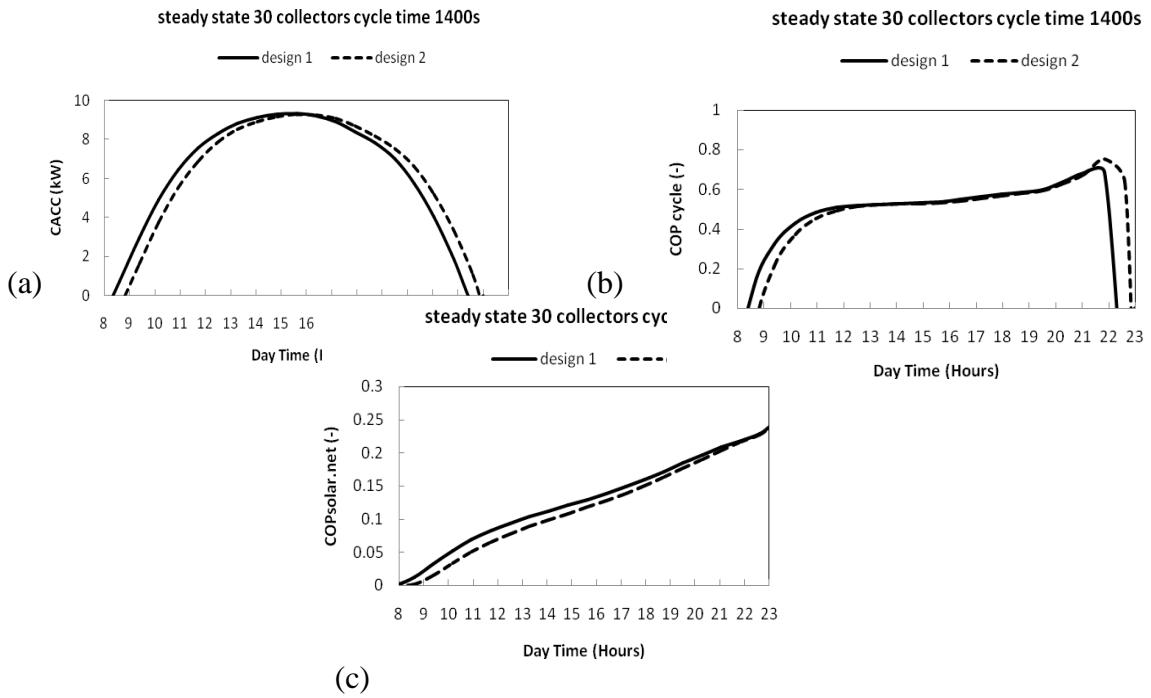

Figure 5. (a) Cyclic average cooling capacity, (b) COP cycle and (c) COPsolar.net of the adsorption chiller at steady state for design 1 & design 2

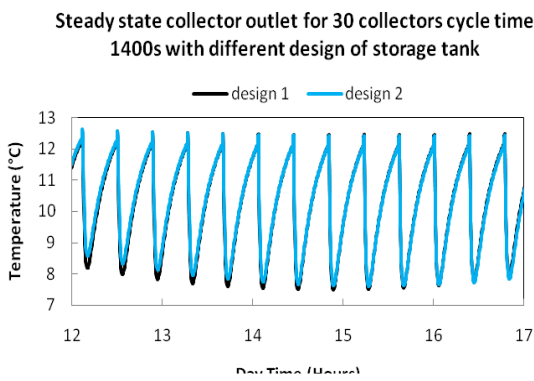

Figure 6. Evaporator outlet design 1 and design 2 at peak hours steady state

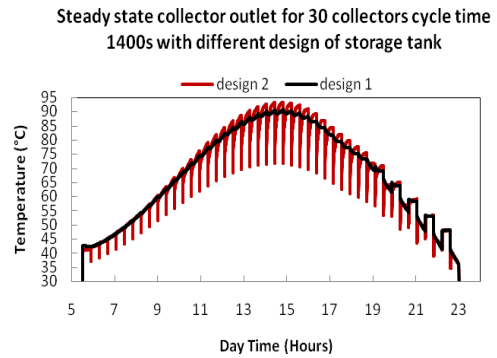

Figure 7. Collector outlet design 1 and design 2 at peak hours steady state

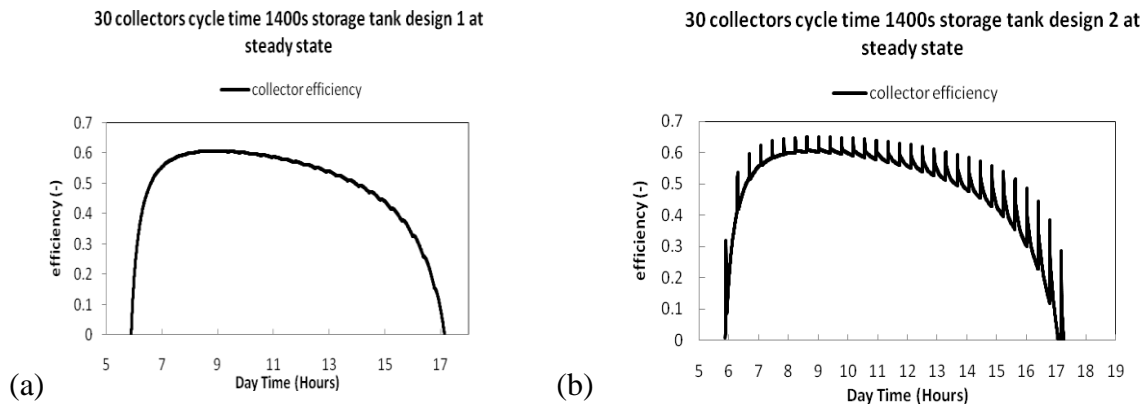

Figure 8. Collector efficiency at steady state (a) storage tank design 1 (b) storage tank design 2

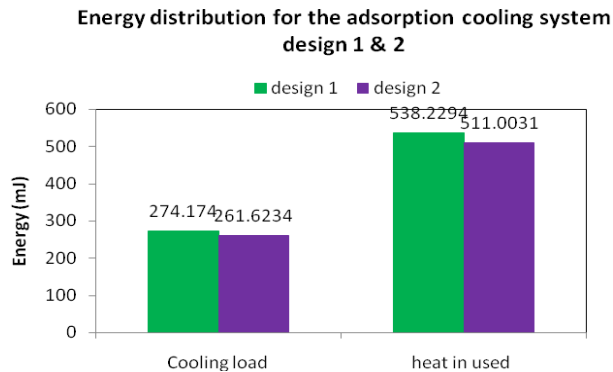

Figure 9. Cooling production and heat in used by the chiller with storage tank design 1 and design 2

Net cooling production by the chiller with storage tank design 1 at steady state for one day is 274.174 mega joule, while it is 261.6234 mega joule with design 2. As a result it needs 538.2294 mega joule heat in used for design 1 and it is 511.0031 mega joule heat for design 2. A bar diagram of energy distribution is presented in Figure 10.

6. Conclusion

In the present paper a storage tank is added with the solar adsorption cooling system in anticipation to enhance both the working hour and the system performance for a solar heat driven adsorption cooling system. Two different designs have been considered. In design 1, heat transfer fluid (water) travels through the desorption bed, loses heat and enters the storage tank, where it will be collected. Storage tank then supplies water to the collector again to complete the cycle of heat transfer fluid. On the other hand, in design 2, collector supplies heated heat transfer

fluid (water) to the storage tank. This heated water then travels through the desorber and return to the collector. In case of both of the designs, optimum cycle time is 1400s with 30 collectors. Comparative studies are presented of temperature histories of different heat exchangers, performances of the chiller for both of the two designs. Also, collector efficiencies are calculated for both of the cases. Longer cycle time extends system working hours and the COP values for both of the cases. However, the overall collector efficiency is 0.68 for both of the designs. Although uniform efficiency is observed for design 1 while it oscillates for design 2. Based on above discussions following conclusions can be drawn.

- Position of the tank effects on the activation time of the chiller. With design1 chiller starts at least 20 minutes earlier than design 2.
- Maximum cooling capacity 9.3 kW is achievable with design 1.
- System working hour is enhanced after sunset with design 2.
- Position of the tank does not have much effect on CACC or COP values of the system.
- Dimension of the tank is directly related with collector area for optimum performance, hence on installation cost.
- System with design 1 ensures at least 4% increase in cooling production than that of design two.
- One need to study economic feasibility over the system performance and installation cost

For better performance, design 1 can be an ideal choice for a solar heat driven adsorption cooling chiller. However, for longer working hours, after sunset, one can favor design 2 as a preferable system. For a tropical country like Bangladesh, abundant solar radiation can be utilized as a primary energy during hot summer and dry winter. Annexure of a hot water reservoir not only serve the purpose of longer activation of an adsorption chiller during summer but also a source of hot water supply in winter season. In need of maximum efficient energy management, one need to study optimum size of reservoir compared to the chiller and operating conditions. Furthermore, multiple bed, advanced cycles and cascaded systems can be studied for the improvement of a solar heat driven adsorption cooling system supported by a storage tank.

Nomenclature

A	Area (m^2)
c_p	specific heat (J/kgK)
I	solar radiation (W/m^2)
L	latent heat of vaporization (J/kg)
\dot{m}	mass flow rate (kg/s)
Q_{st}	heat of adsorption (J/kg)
q	adsorption capacity (kg/kg_s)
t	time (S)
T	temperature (K)
U	heat transfer coefficient (W/m^2K)
W	Mass (kg)

Subscripts

a	adsorber
am	ambient
bed	adsorbent bed
chill	chilled water
con	condenser
cp	collector pipe
cr	collector
d	desorber
eva	evaporator
f	heat transfer fluid (water)
l	liquid
<i>M</i>	metal
s	silica gel
t	tube
tm	tank metal
<i>v</i>	vapor
w	water
wt	tank water

REFERENCES

- Akahira, A., Alam K. C. A., Hamamoto, Y., Akisawa, A. and Kashiwagi, T. (2005). Experimental investigation of mass recovery adsorption refrigeration cycle, *International Journal of Refrigeration*, Vol. 28, pp. 565–572.
- Alam, K. C. A., Saha, B. B. and Akisawa, A. (2013). Adsorption cooling driven by solar collector: a case study for Tokyo solar data, *Applied Thermal Engineering*, Vol. 50, No. 2, pp. 1603-1609.
- Alam, K. C. A., Rouf, R. A., Saha, B. B., Khan, M. A. H. and Meunier, F.(2016). Autonomous adsorption cooling-driven by heat storage collected from solar heat, *Heat Transfer Engineering*, Vol. 37, No. 7-8, pp. 640-649. DOI 10.1080/01457632.2015.1067045, <http://dx.doi.org/10.1080/01457632.2015.1067045>
- Chua, H. T., Ng, K. C., Malek, A., Kashiwagi, T., Akisawa, A. and Saha, B. B. (2001). Multi-bed regenerative adsorption chiller—improving the utilization of waste heat and reducing the chilled water outlet temperature fluctuation, *International Journal of Refrigeration*, Vol. 24, pp. 124–136.
- Clause, M., Alam, K. C. A. and Meunier, F. (2008). Residential air conditioning and heating by means of enhanced solar collectors coupled to an adsorption system, *Solar Energy*, Vol. 82, No. 10, pp. 885-892.
- Hamdy, M., Askalany, A. A., Harby, K. and Kora, N. (2015). An overview on adsorption

- cooling systems powered by waste heat from internal combustion engine, *Renewable and Sustainable Energy Reviews*, Vol. 51, pp. 1223-1234.
- Meunier, F. (1998). Solid sorption heat powered cycles for cooling and heat pump applications, *Applied Thermal Engineering*, Vol. 18, pp. 714-729.
- Meunier, F. (1986). Theoretical performance of solid adsorbent cascading cycles using Zeolite-water and active carbon-methanol pair; four cases studied, *Heat Recovery CHP System*, Vol. 6, No. 6, pp. 491-498.
- Rouf, R. A., Alam, K. C. A., Khan, M. A. H., Ashrafee, T. and Anwer, M. (2013). Solar Adsorption cooling: A case study on the climatic condition of Dhaka, *Journal of Computers*, Vol. 8, No. 5, pp. 1101-1108.
- Rouf, R. A., Alam, K. C. A. and Khan, M. A. H. (2013). Effect of operating conditions on the performance of adsorption solar cooling run by solar collectors, *Procedia Engineering*, Vol. 56, pp. 607-612.
- Shelton, S. V., Wepfer, J. W. and Miles, D. J. (1990). Ramp wave analysis of the solid/vapor heat pump, *ASME J. Energy Resource Technology*, Vol. 112, pp. 69-78.
- Saha, B.B., Boelman, E.C. and Kashiwagi, T. (1995). Computational analysis of an advanced adsorption refrigeration cycle, *Energy*, Vol. 20, pp. 983-994.
- Saha, B. B., Alam, K. C. A., Akisawa, A., Kashiwagi, T., Ng, K. C. and Chua, H. T. (2000). Two-stage non-regenerative silica gel-water adsorption refrigeration cycle, *Proceedings of ASME Advanced Energy System Division, Orlando*, pp. 65-69.
- Saha, B. B., Boelman, E. C. and Kashiwagi, T. (1995). Computer simulation of a silica gel-water adsorption refrigeration cycle- the influence of operating conditions on cooling output and COP, *ASHREA Transactions*, Vol. 101, No 2, pp. 348-357.
- Wang, R. Z. (2001). Performance improvement of adsorption cooling by heat and mass recovery operation, *International Journal of Refrigeration*, Vol. 24, pp. 602-611.
- Wirajati, I. G. A. B., Akisawa, A., Ueda Y. and Miyazaki T. (2015). Experimental investigation of a reheating two-stage adsorption chiller applying fixed chilled water outlet conditions, *Heat Transfer Research*, Vol. 46, No. 3, pp. 293-309.
- Yong, L. and Sumathy, K. (2004). Modeling and simulation of a solar powered two bed adsorption air conditioning system, *Energy Conversion and Management*, Vol. 45, pp. 2761-2775.
- Zhang, G., Wang, D. C., Han, Y. P. and Sun, W. (2011). Simulation of operating characteristics of the silica gel-water adsorption chiller powered by solar energy, *Solar Energy*, Vol. 85, No. 7, pp. 1469-1478.