



12-2015

## Approximate Solutions for the Flow and Heat Transfer due to a Stretching Sheet Embedded in a Porous Medium with Variable Thickness, Variable Thermal Conductivity and Thermal Radiation using Laguerre Collocation Method

M. M. Khader  
*Ibn Saud Islamic University*

Ahmed M. Megahed  
*Benha University*

Follow this and additional works at: <https://digitalcommons.pvamu.edu/aam>



Part of the [Fluid Dynamics Commons](#), and the [Numerical Analysis and Computation Commons](#)

### Recommended Citation

Khader, M. M. and Megahed, Ahmed M. (2015). Approximate Solutions for the Flow and Heat Transfer due to a Stretching Sheet Embedded in a Porous Medium with Variable Thickness, Variable Thermal Conductivity and Thermal Radiation using Laguerre Collocation Method, *Applications and Applied Mathematics: An International Journal (AAM)*, Vol. 10, Iss. 2, Article 12.  
Available at: <https://digitalcommons.pvamu.edu/aam/vol10/iss2/12>

This Article is brought to you for free and open access by Digital Commons @PVAMU. It has been accepted for inclusion in *Applications and Applied Mathematics: An International Journal (AAM)* by an authorized editor of Digital Commons @PVAMU. For more information, please contact [hvkoshy@pvamu.edu](mailto:hvkoshy@pvamu.edu).



# Approximate Solutions for the Flow and Heat Transfer due to a Stretching Sheet Embedded in a Porous Medium with Variable Thickness, Variable Thermal Conductivity and Thermal Radiation using Laguerre Collocation Method

<sup>1</sup>M. M. Khader and <sup>2</sup>Ahmed M. Megahed

<sup>1</sup>Department of Mathematics and Statistics, College of Science  
Al-Imam Mohammad, Ibn Saud Islamic University (IMSIU)  
Riyadh, Saudi Arabia  
[mohamed.khader@fsc.bu.edu.eg](mailto:mohamed.khader@fsc.bu.edu.eg), [mohamedmbd@yahoo.com](mailto:mohamedmbd@yahoo.com)

<sup>2</sup>Department of Mathematics, Faculty of Science  
Benha University, Benha, Egypt  
[ah\\_mg\\_sh@yahoo.com](mailto:ah_mg_sh@yahoo.com)

Received: April 3, 2015; Accepted: August 11, 2015

## Abstract

In this article, a numerical approach is given for studying the flow of a Newtonian fluid over an impermeable stretching sheet embedded in a porous medium with a power law surface velocity and variable thickness in the presence of thermal radiation. The flow is caused by a non-linear stretching of a sheet. Thermal conductivity of the fluid is assumed to vary linearly with temperature. The governing PDEs are transformed into a system of coupled non-linear ODEs which are using appropriate boundary conditions for various physical parameters. The proposed method is based on replacement of the unknown function by truncated series of well known Laguerre expansion of functions. An approximate formula of the integer derivative is introduced. The introduced method converts the proposed equations by means of collocation points to a system of algebraic equations with Laguerre coefficients. Thus, by solving this system of equations, the Laguerre coefficients are obtained. The effects of the porous parameter, the wall thickness parameter, the radiation parameter, thermal conductivity parameter, and the Prandtl number on the flow and temperature profiles are presented. Moreover, the local skin-friction and Nusselt numbers are presented. Comparison of obtained numerical results is made with previously published results in some special cases. The results attained in this paper confirm the idea that the proposed method is powerful mathematical tool and it can be applied to a large class of nonlinear problems arising in different fields of science and engineering.

**Keywords:** Newtonian fluid, stretching sheet, thermal radiation, variable thermal conductivity, variable thickness, Laguerre collocation method, numerical simulation

**MSC 2010 No.:** 41A10; 65N35; 76M22

## 1. Introduction

The study of flow and heat transfer of a Newtonian fluid over a stretching surface issuing from a slit has gained considerable attention from many researchers due to its importance in many industrial applications, such as extraction of polymer sheet, wire drawing, paper production, glass-fiber production, hot rolling, solidification of liquid crystals, petroleum production, continuous cooling and fibers spinning, exotic lubricants, and suspension solutions. Much work on the boundary-layer Newtonian fluids has been carried out both experimentally and theoretically. Crane (1970) was the first one who studied the stretching problem taking into account the fluid flow over a linearly stretched surface. There has been a great deal of the work done on Newtonian fluid flow and heat transfer over a stretching surface, but only a few recent studies are cited here. Gupta and Gupta (1979) analyzed the stretching problem with a constant surface temperature, while Soundalgekar and Ramana (1980) have investigated the constant surface velocity case with a power-law temperature variation. Grubka and Bobba (1985) have analyzed the stretching problem for a surface moving with a linear velocity and with a variable surface temperature. Chen and Char (1988) investigated the heat transfer characteristics over a continuous stretching sheet with variable surface temperature. Using the homotopy analysis method (HAM), series solutions were obtained by Hayat et al. (2008) for the stretching sheet problem with mixed convection.

Despite the practical importance of the flow in a porous medium, all the above-mentioned works do not consider the situations where the flow in fluid-saturated porous media arise. The study of the flow in fluid-saturated porous media due to a stretching sheet is important in engineering problems, such as the design of building components for energy consideration, soil science, mechanical engineering, control of pollutant spread in groundwater, thermal insulation systems, compact heat exchangers, solar power collectors, and food industries. Because of such important practical applications, many investigators have modeled the behavior of a boundary layer flow embedded in a porous medium. Cheng and Minkowycz (1977) studied the problem of free convection about a vertical impermeable flat plate in a Darcy porous medium. Elbashbeshy and Bazid (2004) studied flow and heat transfer in a porous medium over a stretching surface with internal heat generation and suction/blowing when the surface is held at a constant temperature. Cortell (2005) has presented an analytical solution of the problem considered by Elbashbeshy and Bazid (2004) considering the constant surface temperature and prescribed surface temperature. Recently Hayat et al. (2010) used HAM to give analytical solution for flow through porous medium.

In all the previous investigations, the effects of radiation on the flow and heat transfer have not been provided. Radiative heat transfer flow is very important in manufacturing industries for the design of reliable equipments, nuclear plants, gas turbines and various propulsion devices for aircraft, missiles, satellites and space vehicles. Also, the effect of thermal radiation on the forced and free convection flows are important in the context of space technology and processes involving high temperature. Based on these applications, Hossain et al. (1999) and Elbashbeshy and Demain (2002) have studied the thermal radiation of a gray fluid which is emitting and absorbing radiation in non-scattering medium. Abel and Mahesha (2008) studied the effect of radiation in different situations. Recently, Battaler (2008) has studied the effect of thermal radiation on the laminar

boundary layer about a flat plate.

Historically the study on boundary layer flows over a stretching sheet with variable thickness was studied by Fang et al. (2012). So far no attention has been given to the effects of the non-flatness on the stretching sheet problems considering a variable sheet thickness. The purpose of the present paper is to investigate the numerical solution for the variable thermal conductivity effect on the flow and heat transfer of a Newtonian fluid-saturated porous medium over a stretching sheet with variable thickness in the presence of thermal radiation (see Pedro (2015)).

Spectral collocation methods are efficient and highly accurate techniques for numerical solution of non-linear differential equations (Sweilam et al. (2012)). The basic idea of the spectral collocation method is to assume that the unknown solution  $y(x)$  can be approximated by a linear combination of some basis functions, called the trial functions, such as orthogonal polynomials. Khader (2011) introduced an efficient numerical method for solving the fractional diffusion equation using the shifted Chebyshev polynomials. In Cheng and Ben (2002) the generalized Laguerre polynomials were used to compute a spectral solution of a non-linear boundary value problems. The generalized Laguerre polynomials constitute a complete orthogonal sets of functions on the semi-infinite interval  $[0, \infty)$ . Convolution structures of Laguerre polynomials were presented in Askey and Gasper (1977).

The Laguerre collocation method is used to solve many problems, in more papers such as Khabibrakhmanov and Summers (1998) and Sweilam et al. (2012). In this work, we use the properties of the Laguerre polynomials and the derived approximate formula of the integer derivative  $D^{(n)}y(x)$  to solve numerically the proposed problem.

## 2. Formulation of the problem

Consider a steady, two-dimensional boundary layer flow of an incompressible Newtonian fluid over a continuously impermeable stretching sheet embedded in a porous medium. The origin is located at a slit, through which the sheet (see Figure 1) is drawn through the fluid medium. The  $x$ -axis is chosen along the sheet and  $y$ -axis is taken normal to it. The stretching surface has the velocity  $U_w = C(x+b)^m$ , where  $C$  is a constant. We assume that the sheet is not flat in which it is specified as  $y = A(x+b)^{\frac{1-m}{2}}$ , where  $A$  is a very small constant so that the sheet is sufficiently thin and  $m$  is the velocity power index. We must observe that our problem is valid only for  $m \neq 1$ , because for  $m = 1$ , the problem reduces to a flat sheet. Likewise, the fluid properties are assumed to be constant except for thermal conductivity variations in the temperature.

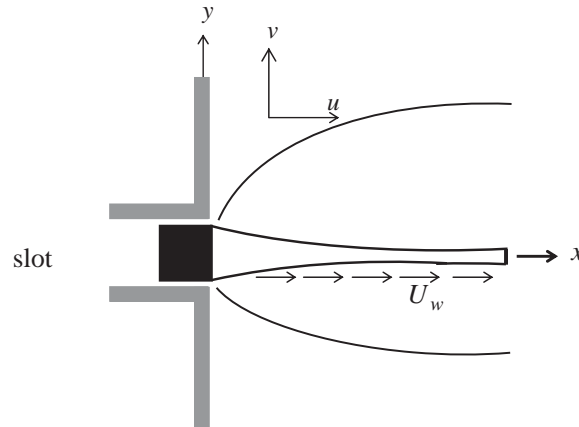

Figure 1. Schematic of a stretching sheet with variable sheet thickness

Making the usual boundary layer approximations for the Newtonian fluid, the steady two-dimensional boundary-layer equations taking into account the thermal radiation effect in the energy equation can be written as

$$\frac{\partial u}{\partial x} + \frac{\partial v}{\partial y} = 0, \quad (1)$$

$$u \frac{\partial u}{\partial x} + v \frac{\partial u}{\partial y} = \nu \frac{\partial^2 u}{\partial y^2} - \frac{\mu}{\rho k} u, \quad (2)$$

$$\rho c_p \left( u \frac{\partial T}{\partial x} + v \frac{\partial T}{\partial y} \right) = \frac{\partial}{\partial y} \left( \kappa \frac{\partial T}{\partial y} \right) - \frac{\partial q_r}{\partial y}, \quad (3)$$

where  $u$  and  $v$  are the velocity components in  $x$  and  $y$  directions, respectively.  $\rho$  and  $\kappa$  are the fluid density and the thermal conductivity, respectively.  $T$  is the temperature of the fluid,  $\nu$  is the fluid kinematic viscosity,  $c_p$  is the specific heat at constant pressure,  $\mu$  is the fluid viscosity,  $k$  is the permeability of the porous medium and  $q_r$  is the radiative heat flux.

The radiative heat flux  $q_r$  is employed according to Rosseland approximation (Raptis (1998)) such that

$$q_r = -\frac{4\sigma^*}{3k^*} \frac{\partial T^4}{\partial y}, \quad (4)$$

where  $\sigma^* = 5.6697 \times 10^{-8} \text{ Wm}^{-2}\text{K}^{-4}$  is the Stefan-Boltzmann constant and  $k^*$  is the mean absorption coefficient. Following Raptis (1999), we assume that the temperature differences within the flow are sufficiently small such that  $T^4$  may be expressed as a linear function of the temperature. Expanding  $T^4$  in the Taylor series about  $T_\infty$  and neglecting higher-order terms, we have

$$T^4 \cong 4T_\infty^3 T - 3T_\infty^4. \quad (5)$$

The physical and mathematical advantage of the Rosseland formula (5) consists of the fact that it can be combined with Fourier's second law of conduction to an effective conduction-radiation flux  $q_{eff}$  in the form

$$q_{eff} = -\left( \kappa + \frac{16\sigma^* T_\infty^3}{3k^*} \right) \frac{\partial T}{\partial y} = -\kappa_{eff} \frac{\partial T}{\partial y}, \quad (6)$$

where  $\kappa_{eff} = \kappa + \frac{16\sigma^*T_\infty^3}{3k^*}$  is the effective thermal conductivity. So, the steady energy balance equation including the net contribution of the radiation emitted from the hot wall and absorbed in the colder fluid, takes the form

$$\rho c_p \left( u \frac{\partial T}{\partial x} + v \frac{\partial T}{\partial y} \right) = \frac{\partial}{\partial y} \left( \kappa_{eff} \frac{\partial T}{\partial y} \right). \tag{7}$$

To obtain similarity solutions, it is assumed that the permeability of the porous medium  $k(x)$  is of the form

$$k(x) = k_0(x + b)^{1-m}, \tag{8}$$

where  $k_0$  is the permeability parameter. The boundary conditions can be written as

$$u \left( x, A(x + b)^{\frac{1-m}{2}} \right) = C(x + b)^m, \quad v \left( x, A(x + b)^{\frac{1-m}{2}} \right) = 0, \quad T \left( x, A(x + b)^{\frac{1-m}{2}} \right) = T_w, \tag{9}$$

$$u(x, \infty) = 0, \quad T(x, \infty) = T_\infty. \tag{10}$$

The mathematical analysis of the problem is simplified by introducing the following dimensionless coordinates

$$\zeta = y \sqrt{C \left( \frac{m+1}{2} \right) \left( \frac{(x+b)^{m-1}}{\nu} \right)}, \quad \psi(x, y) = \sqrt{\nu C \left( \frac{2}{m+1} \right) (x+b)^{m+1}} F(\zeta), \tag{11}$$

$$\Theta(\zeta) = \left( \frac{T - T_\infty}{T_w - T_\infty} \right),$$

where  $\zeta$  is the similarity variable,  $\psi(x, y)$  is the stream function which is defined in the classical form as  $u = \partial\psi/\partial y$  and  $v = -\partial\psi/\partial x$  and  $\Theta(\zeta)$  is the dimensionless temperature.

In this study, the equation for the dimensionless thermal conductivity  $\kappa$  is generalized for the temperature dependence as follows (Chiam (1997), Mahmoud and Megahed (2009))

$$\kappa = \kappa_\infty(1 + \epsilon\Theta), \tag{12}$$

where  $\kappa_\infty$  is the ambient thermal conductivity and  $\epsilon$  is the thermal conductivity parameter.

Upon using these variables, the boundary layer governing Equations (1)-(3) can be written in a non-dimensional following form

$$F''' + FF'' - \frac{2m}{m+1}F'^2 - DF' = 0, \tag{13}$$

$$\left( \frac{1+R}{Pr} \right) \left( (1 + \epsilon\Theta)\Theta'' + \epsilon\Theta'^2 \right) + F\Theta' = 0, \tag{14}$$

where  $D = \frac{2\nu}{k_0C(m+1)}$  is the porous parameter,  $Pr = \frac{\mu c_p}{\kappa_\infty}$  is the Prandtl number and  $R = \frac{16\sigma^*T_\infty^3}{3k^*\kappa_\infty}$  is the radiation parameter.

The transformed boundary conditions are

$$F(\alpha) = \alpha \left( \frac{1-m}{1+m} \right), \quad F'(\alpha) = 1, \quad \Theta(\alpha) = 1, \tag{15}$$

$$F'(\infty) = 0, \quad \Theta(\infty) = 0, \quad (16)$$

where  $\alpha = A\sqrt{\frac{C(m+1)}{2\nu}}$  is a parameter related to the thickness of the wall and  $\zeta = \alpha = A\sqrt{\frac{C(m+1)}{2\nu}}$  indicates the plate surface. To facilitate the computation, we define  $F(\zeta) = F(\eta - \alpha) = f(\eta)$  and  $\Theta(\zeta) = \Theta(\eta - \alpha) = \theta(\eta)$ . The similarity equations and the associated boundary conditions become

$$f''' + ff'' - \frac{2m}{m+1}f'^2 - Df' = 0, \quad (17)$$

$$\left(\frac{1+R}{Pr}\right) \left((1+\epsilon\theta)\theta'' + \epsilon\theta'^2\right) + f\theta' = 0, \quad (18)$$

$$f(0) = \alpha \left(\frac{1-m}{1+m}\right), \quad f'(0) = 1, \quad \theta(0) = 1, \quad (19)$$

$$f'(\infty) = 0, \quad \theta(\infty) = 0, \quad (20)$$

where the prime denotes differentiation with respect to  $\eta$ . Based on the variable transformation, the solution domain will be fixed from 0 to  $\infty$ .

The physical quantities of primary interest are the local skin-friction coefficient  $Cf$  and the local Nusselt number  $Nu$  which are defined as

$$Cf = -2\sqrt{\frac{m+1}{2}}Re_x^{-\frac{1}{2}}f''(0), \quad Nu = -\sqrt{\frac{m+1}{2}}Re_x^{\frac{1}{2}}\theta'(0), \quad (21)$$

where  $Re_x = \frac{U_w X}{\nu}$  is the local Reynolds number and  $X = x + b$ .

### 3. An approximate derivative of $L_i^{(\alpha)}(x)$ and its convergence analysis

The generalized Laguerre polynomials  $[L_i^{(\alpha)}(x)]_{i=0}^{\infty}$ ,  $\alpha > -1$  are defined on the unbounded interval  $(0, \infty)$  and can be determined with the aid of the following recurrence formula

$$(i+1)L_{i+1}^{(\alpha)}(x) + (x-2i-\alpha-1)L_i^{(\alpha)}(x) + (i+\alpha)L_{i-1}^{(\alpha)}(x) = 0, \quad i = 1, 2, \dots, \quad (22)$$

where,  $L_0^{(\alpha)}(x) = 1$  and  $L_1^{(\alpha)}(x) = \alpha + 1 - x$ .

The analytic form of these polynomials of degree  $i$  is given by

$$L_i^{(\alpha)}(x) = \sum_{k=0}^i \frac{(-1)^k}{k!} \binom{i+\alpha}{i-k} x^k, \quad L_i^{(\alpha)}(0) = \binom{i+\alpha}{i}. \quad (23)$$

Any function  $u(x)$  belongs to the space  $L_w^2[0, \infty)$  of all square integrable functions on  $[0, \infty)$  with weight function  $w(x)$  and can be expanded in the following Laguerre series  $u(x) = \sum_{i=0}^{\infty} c_i L_i^{(\alpha)}(x)$ , where the coefficients  $c_i$  are given by

$$c_i = \frac{\Gamma(i+1)}{\Gamma(i+\alpha+1)} \int_0^{\infty} x^\alpha e^{-x} L_i^{(\alpha)}(x) u(x) dx, \quad i = 0, 1, \dots$$

Consider only the first  $(m + 1)$ -terms of generalized Laguerre polynomials, so we can write

$$u_m(x) = \sum_{i=0}^m c_i L_i^{(\alpha)}(x). \tag{24}$$

For more details on Laguerre polynomials, its definitions, and properties, see Cheng and Ben (2002), Talay (2009), and Khabibrakhmanov and Summers (1998).

The main approximate formula of the derivative of  $u(x)$  is given in the following theorem.

**Theorem 3.1.** (Khader (2014))

Let  $u(x)$  be approximated by the generalized Laguerre polynomials as (24) and also suppose  $n \in \mathbb{N}$ . Then its approximated derivative can be written in the following form

$$D^{(n)}(u_m(x)) \cong \sum_{i=n}^m \sum_{k=n}^i c_i \gamma_{i,k,n} x^{k-n}, \quad \gamma_{i,k,n} = \frac{(-1)^k}{(k+n)!} \binom{i+\alpha}{i-k}. \tag{25}$$

**Theorem 3.2.** (Khader (2014))

The derivative of order  $n$  for the generalized Laguerre polynomials can be expressed in terms of the generalized Laguerre polynomials themselves in the following form

$$D^{(n)}L_i^{(\alpha)}(x) = \sum_{k=n}^i \sum_{j=0}^{k-n} \Omega_{ijk} L_j^{(\alpha)}(x), \quad i = n, n+1, \dots, m, \tag{26}$$

where 
$$\Omega_{ijk} = \sum_{r=0}^j \frac{(-1)^{r+k} \Gamma(\alpha+i+1)(j)! \Gamma(k+\alpha-n+r+1)}{(k-n)!(i-k)! \Gamma(\alpha+k+1) r!(j-r)! (\alpha+r)!}.$$

#### 4. Procedure solution

In this section, we present the proposed method to solve numerically the system of ordinary differential equations of the form (17)-(18). The unknown functions  $f(\eta)$  and  $\theta(\eta)$  may be expanded by finite series of Laguerre polynomials in the following approximation

$$f_m(\eta) = \sum_{i=0}^m c_i L_i^{(\alpha)}(\eta), \quad \theta_m(\eta) = \sum_{i=0}^m d_i L_i^{(\alpha)}(\eta). \tag{27}$$

From Equations (17)-(18), (27), and Theorem 3.1 we have

$$\begin{aligned} & \sum_{i=3}^m \sum_{k=3}^i c_i \gamma_{i,k,3} \eta^{k-3} + \sum_{i=0}^m c_i L_i^{(\alpha)}(\eta) \left( \sum_{i=2}^m \sum_{k=2}^i c_i \gamma_{i,k,2} \eta^{k-2} \right) \\ & - \left( \frac{2m}{1+m} \right) \left( \sum_{i=1}^m \sum_{k=1}^i c_i \gamma_{i,k,1} \eta^{k-1} \right)^2 - D \sum_{i=1}^m \sum_{k=1}^i c_i \gamma_{i,k,1} \eta^{k-1} = 0, \end{aligned} \tag{28}$$



$$\begin{aligned} & \sum_{i=2}^m \sum_{k=2}^i d_i \gamma_{i,k,2} \eta^{k-2} + \epsilon \sum_{i=0}^m d_i L_i^{(\alpha)}(\eta) \left( \sum_{i=2}^m \sum_{k=2}^i d_i \gamma_{i,k,2} \eta^{k-2} \right) \\ & + \epsilon \left( \sum_{i=1}^m \sum_{k=1}^i d_i \gamma_{i,k,1} \eta^{k-1} \right)^2 + \frac{Pr}{1+R} \left( \sum_{i=0}^m c_i L_i^{(\alpha)}(\eta) \right) \left( \sum_{i=1}^m \sum_{k=1}^i d_i \gamma_{i,k,1} \eta^{k-1} \right) = 0. \end{aligned} \quad (29)$$

We now collocate Equations (28)-(29) at  $(m - n + 1)$  points  $\eta_s$ ,  $s = 0, 1, \dots, m - n$  as

$$\begin{aligned} & \sum_{i=3}^m \sum_{k=3}^i c_i \gamma_{i,k,3} \eta_s^{k-3} + \sum_{i=0}^m c_i L_i^{(\alpha)}(\eta_s) \left( \sum_{i=2}^m \sum_{k=2}^i c_i \gamma_{i,k,2} \eta_s^{k-2} \right) \\ & - \left( \frac{2m}{1+m} \right) \left( \sum_{i=1}^m \sum_{k=1}^i c_i \gamma_{i,k,1} \eta_s^{k-1} \right)^2 - D \sum_{i=1}^m \sum_{k=1}^i c_i \gamma_{i,k,1} \eta_s^{k-1} = 0, \end{aligned} \quad (30)$$

$$\begin{aligned} & \sum_{i=2}^m \sum_{k=2}^i d_i \gamma_{i,k,2} \eta_s^{k-2} + \epsilon \sum_{i=0}^m d_i L_i^{(\alpha)}(\eta_s) \left( \sum_{i=2}^m \sum_{k=2}^i d_i \gamma_{i,k,2} \eta_s^{k-2} \right) \\ & + \epsilon \left( \sum_{i=1}^m \sum_{k=1}^i d_i \gamma_{i,k,1} \eta_s^{k-1} \right)^2 + \frac{Pr}{1+R} \left( \sum_{i=0}^m c_i L_i^{(\alpha)}(\eta_s) \right) \left( \sum_{i=1}^m \sum_{k=1}^i d_i \gamma_{i,k,1} \eta_s^{k-1} \right) = 0. \end{aligned} \quad (31)$$

For suitable collocation points, we use roots of Laguerre polynomial  $L_{m-n+1}^{(\alpha)}(\eta)$ . Also, by substituting Formula (27) in the boundary conditions (19)-(20), we can obtain five equations as follows

$$\sum_{i=0}^m (-1)^i c_i = \alpha \left( \frac{2m}{m+1} \right), \quad \sum_{i=0}^m (-1)^i d_i = 1, \quad \sum_{i=0}^m d_i = 0, \quad \sum_{i=0}^m \ell_{1i} c_i = 1, \quad \sum_{i=0}^m \ell_{2i} c_i = 0, \quad (32)$$

where  $\ell_{1i} = L_i^{(\alpha)}(0)$ ,  $\ell_{2i} = L_i^{(\alpha)}(\eta_\infty)$ .

Equations (30)-(31), together with five equations of the boundary conditions (32), give a system of  $(2m + 2)$  algebraic equations which can be solved, for the unknowns  $c_i$ ,  $d_i$ ,  $i = 0, 1, \dots, m$ , using Newton iteration method. In our numerical study we take  $m = 5$ , i.e., five terms of the truncated series solution (27), at  $\eta_\infty = 15$ .

## 5. Results and discussion

Tables 1 and 2 clearly reveal that the present solution using the Laguerre collocation method shows excellent agreement with the existing solutions in the literature (Fang et al. (2012)). This analysis shows that the proposed method is suitable for the problems of boundary layer flow

in fluid-saturated porous medium. This section provides the behavior of parameters involved in the expressions of heat transfer characteristics for the stretching sheet. Numerical evaluation for the solutions of this problem is performed and the results are illustrated graphically in Figure 2 through Figure 10. The study of flow in porous media is very important in approximating the shape of spherical particles or cylindrical fibers which better fit the model of permeability assumed for the analysis. The effects of the porous parameter  $D$  on velocity and temperature profiles are shown in Figures 2 and 3, respectively. It is observed that the velocity decreases for increasing values of porous parameter. Furthermore, the momentum boundary layer thickness decreases as porous parameter  $D$  increases. Figure 3 elucidates that the fluid temperature enhance with an increase in the porous parameter.

Table 1. Comparison of the Numerical Value  $-f''(0)$ , Obtained by Laguerre Collocation Method for  $\alpha = 0.5, \lambda = 0$  with Fang et al. (2012)

$m$	10.00	9.00	7.00	5.00	3.00	2.00	1.00	0.50	0.00	-0.50
$-f''(0)$	1.0603	1.0589	1.0550	1.0486	1.0359	1.0234	1.0000	0.9799	0.9576	1.1667
Present work	1.0602	1.0589	1.0550	1.0486	1.0358	1.0235	1.0000	0.97989	0.9576	1.1667

Table 2. Comparison of the Numerical Value  $-f''(0)$ , Obtained by Laguerre Collocation Method for  $\alpha = 0.25, \lambda = 0$  with Fang et al. (2012)

$m$	10.00	9.00	7.00	5.00	3.00	1.00	0.50	0.00	-1/3	-0.50
$-f''(0)$	1.1434	1.1405	1.1326	1.1186	1.0905	1.0000	0.9338	0.78439	0.5000	0.0833
Present work	1.1434	1.1405	1.1326	1.1186	1.0905	1.0000	0.9338	0.7843	0.5000	0.0832

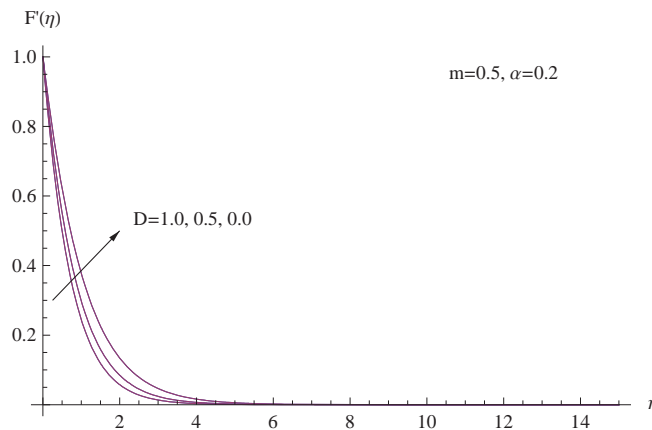

Figure 2. The behavior of the velocity distribution for various values of  $D$

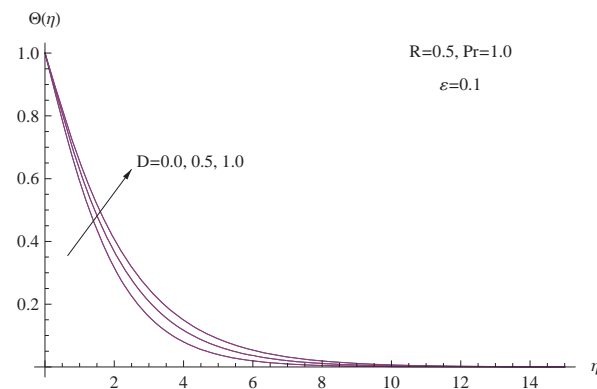

Figure 3. The behavior of the temperature distribution for various values of  $D$

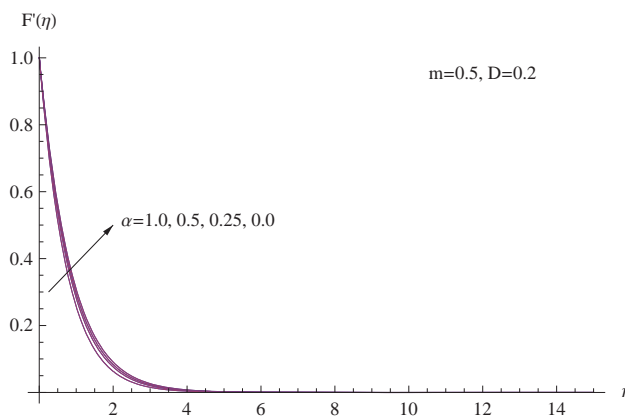

Figure 4-a. The behavior of the velocity distribution for various values of  $\alpha$  with  $m = 0.5$

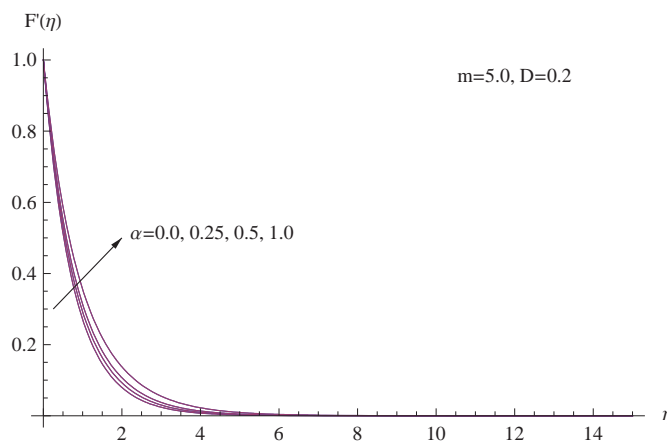

Figure 4-b. The behavior of the velocity distribution for various values of  $\alpha$  with  $m = 5$

The effects of wall thickness parameter on the fluid flow and the temperature distribution have been analyzed and the results are presented in Figures 4-5. From Figure 4, it is clear that the velocity at any point near to the plate decreases as the wall thickness parameter increases for

$m < 1$  and the reverse is true for  $m > 1$ . Also, it is obvious from these figures that the thickness of the boundary layer becomes thinner for a higher value of  $\alpha$  when  $m < 1$  and becomes thicker for a higher value of  $\alpha$  when  $m > 1$ .

Figure 5 displays that the wall thickness parameter decreased the thickness of the thermal boundary layer and enhanced the rate of heat transfer for  $m < 1$  whereas the reverse trend is observed as  $m > 1$ . Physically, increasing the value of  $\alpha$  when  $m < 1$  will decrease the flow velocity because under the variable wall thickness not all the pulling force of the stretching sheet can be transmitted to the fluid causing a decrease for both friction between the fluid layers and temperature distribution for the fluid. But when  $m > 1$  the velocity of the flow layers will increase causing an enhancement for the friction force between this layers and thus increasing its temperature. Likewise for a higher value of  $\alpha$ , the thermal boundary layer becomes thinner when  $m < 1$  compared with the case of  $m > 1$ .

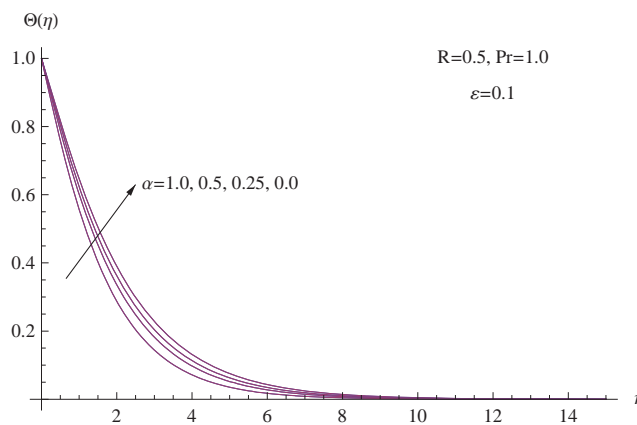

Figure 5-a. The behavior of the temperature distribution for various values of  $\alpha$  with  $m = 0.5$

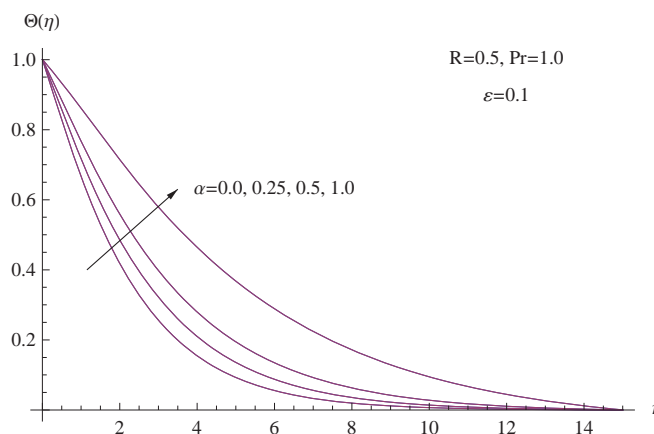

Figure 5-b. The behavior of the temperature distribution for various values of  $\alpha$  with  $m = 5$

Figure 6 shows that the velocity rises with a decrease in the values of the velocity power index  $m$ . This implies the momentum boundary thickness becomes thinner as the  $m$  increases along the sheet and the reverse is true away from it.

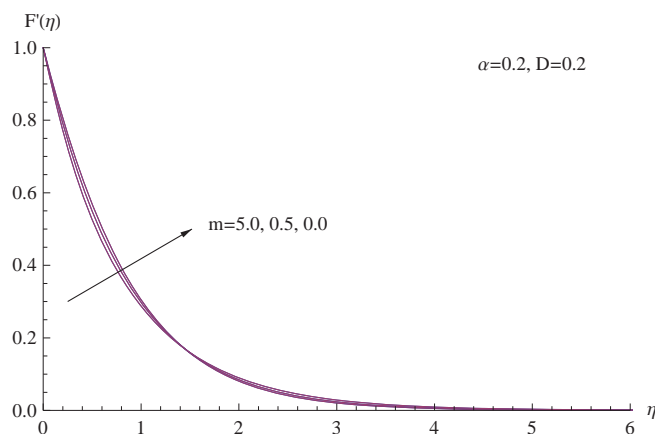

Figure 6. The behavior of the velocity distribution for various values of  $m$

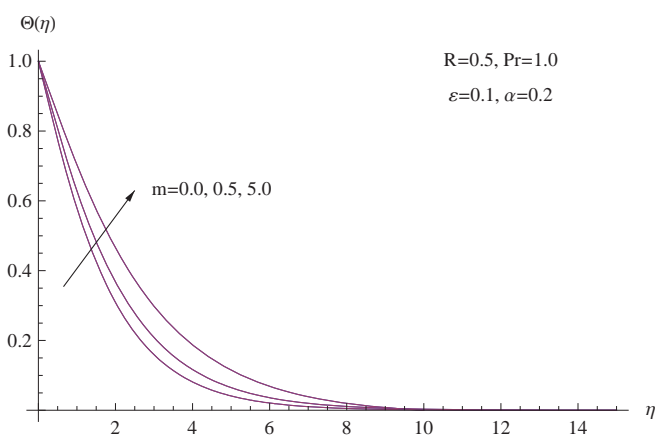

Figure 7. The behavior of the temperature distribution for various values of  $m$

Figure 7 displays the influence of the velocity power index parameter  $m$  on the temperature profiles. It is clearly seen from this figure that increasing the value of  $m$  produces an increase in the temperature profiles. It further shows that the larger the value of  $m$  the higher the magnitude of the thermal boundary thickness will be.

In Figure 8 we have varied the thermal conductivity parameter  $\epsilon$  keeping the values of all other parameters fixed. Figure 8 reveals that the temperature profile as well as the thickness of the thermal boundary layer increase when  $\epsilon$  increases.

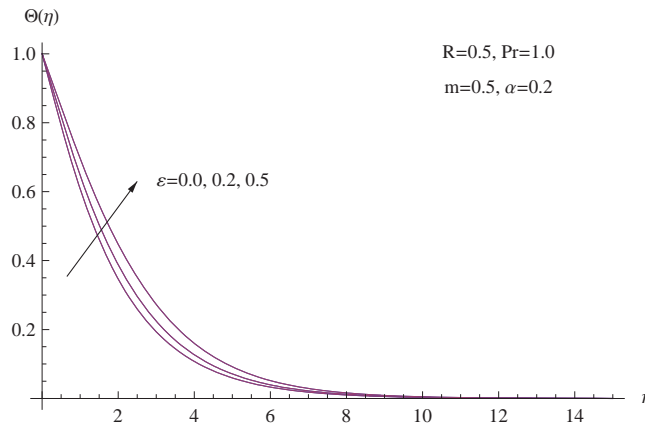

Figure 8. The behavior of the temperature distribution for various values of  $\epsilon$

Figure 9 illustrates the effects of radiation parameter  $R$  on the temperature profiles when other parameters held constant. It is depicted that the temperature field and the thermal boundary layer thickness increase with the increase in  $R$ .

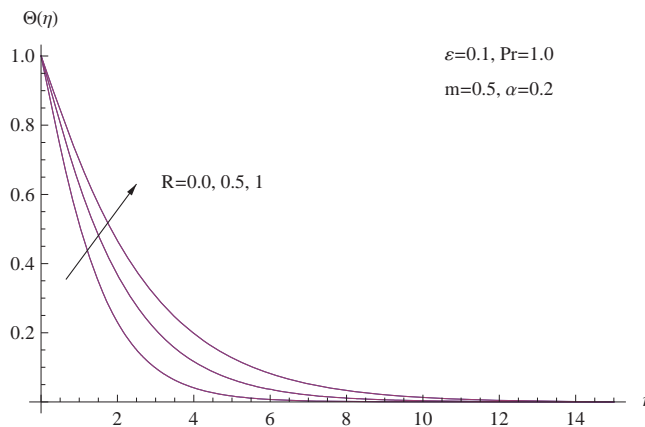

Figure 9. The behavior of the temperature distribution for various values of  $R$

It is observed from Figure 10 that an increase in the Prandtl number results in decreases in the heat transfer profiles. The reason is that increasing values of Prandtl number are equivalent to decreasing the thermal conductivities and therefore heat is able to diffuse away from the heated sheet more rapidly. Hence in the case of increasing Prandtl number, the boundary layer is thinner and the heat transfer is reduced.

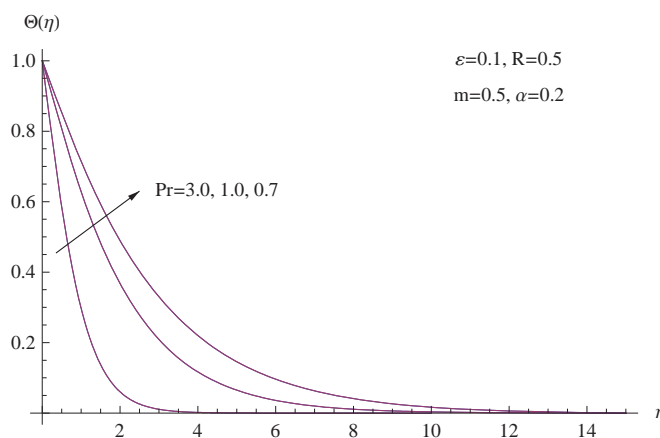

Figure 10. The behavior of the temperature distribution for various values of  $Pr$

Table 3 shows the influence of the porous parameter  $D$ , wall thickness parameter  $\alpha$ , the velocity power index parameter  $m$ , the radiation parameter  $R$ , the Prandtl number  $Pr$ , and the thermal conductivity parameters  $\epsilon$  on the local skin friction coefficient and the local Nusselt number. It is noticed that increases in the wall thickness parameter leads to an increase in both the local skin-friction coefficient and the local Nusselt number. Likewise, the local Nusselt number is reduced but the skin-friction coefficient is increased with increases for both values of porous parameter and velocity power index parameter. Also, an increase in the Prandtl number causes an increase in the local Nusselt number. This is because the fluid with larger Prandtl number possesses larger heat capacity and hence intensifies the heat transfer. Moreover, it is observed that the values of the local Nusselt number decreases with increases in both the thermal conductivity parameter and the radiation parameter.

Table 3. Values of  $-f''(0)$  and  $-\theta'(0)$  for Various Values of  $D, \alpha, m, \epsilon, R$  and  $Pr$ 

$D$	$\alpha$	$m$	$\epsilon$	$R$	$Pr$	$-f''(0)$	$-\theta'(0)$
0.0	0.2	0.5	0.1	0.5	1.0	0.92415	0.441854
0.5	0.2	0.5	0.1	0.5	1.0	1.16835	0.401896
1.0	0.2	0.5	0.1	0.5	1.0	1.36946	0.372239
0.5	0.0	0.5	0.1	0.5	1.0	1.13345	0.375139
0.5	0.25	0.5	0.1	0.5	1.0	1.17745	0.408659
0.5	0.5	0.5	0.1	0.5	1.0	1.22258	0.443236
0.5	1.0	0.5	0.1	0.5	1.0	1.31669	0.515145
0.5	0.2	0.0	0.1	0.5	1.0	1.04434	0.472787
0.5	0.2	0.5	0.1	0.5	1.0	1.16867	0.401809
0.5	0.2	5.0	0.1	0.5	1.0	1.32715	0.303359
0.5	0.2	0.5	0.0	0.5	1.0	1.16812	0.434859
0.5	0.2	0.5	0.2	0.5	1.0	1.16834	0.373947
0.5	0.2	0.5	0.5	0.5	1.0	1.16854	0.310646
0.5	0.2	0.5	0.1	0.0	1.0	1.16834	0.547756
0.5	0.2	0.5	0.1	0.5	1.0	1.16876	0.401887
0.5	0.2	0.5	0.1	1.0	1.0	1.16890	0.319509
0.5	0.2	0.5	0.1	0.5	0.7	1.16815	0.302212
0.5	0.2	0.5	0.1	0.5	1.0	1.16865	0.401834
0.5	0.2	0.5	0.1	0.5	3.0	1.16848	0.896355

## 6. Conclusions

In this paper, the Laguerre collocation method is used to investigate the approximate solution of the resulting non-linear system of ODEs for the problem of flow and heat transfer in a quiescent Newtonian fluid flow caused solely by a stretching sheet which is embedded in a porous medium with variable thickness, variable thermal conductivity, and thermal radiation. The fluid thermal conductivity is assumed to vary as a linear function of temperature. A comparison with previously published work was performed and the results were found to be in excellent agreement. A systematic study on the effects of the various parameters on flow and heat transfer characteristics is carried out. It was found that the effect of increasing values of the porous parameter, the velocity power index parameter, thermal conductivity parameter, and the radiation parameter reduce the local Nusselt number. On the other hand it was observed that the local Nusselt number increases as the Prandtl number and the wall thickness parameter increases. Moreover, it is interesting to find that as the porous parameter, wall thickness parameter, and the velocity power index parameter increase in magnitude, this causes the fluid to slow down past the stretching sheet, and the skin-friction coefficient increases in magnitude. From the presented results, we can see that the numerical solution is in excellent agreement with those obtained by other methods.



### ***Acknowledgments***

*The authors are very grateful to the editor and the referee for carefully reading the paper and for their comments and suggestions, which have improved the paper.*

### REFERENCES

- Abel, M. S. and Mahesha, N. (2008). Heat transfer in MHD viscoelastic fluid flow over a stretching sheet with variable thermal conductivity, non-uniform heat source and radiation, *Applied Mathematical Modelling*, Vol. 32, pp. 1965-1983.
- Askey, R. and Gasper, G. (1977). Convolution structures for Laguerre polynomials, *Journal d'Anal. Mathematics*, Vol. 31, pp. 48-68.
- Bataller, R. C. (2008). Radiation effects in the Blasius flow, *Applied Mathematics and Computation*, Vol. 198, pp. 333-338.
- Chen, C. K. and Char, M. (1988). Heat transfer on a continuous stretching surface with suction or blowing, *Journal of Mathematical Analysis and Applications*, Vol. 35, pp. 568-580.
- Cheng, P. and Minkowycz, W. J. (1977). Free convection about a vertical flat plate embedded in a porous medium with application to heat transfer from a dike, *Journal Geophysics Resources*, Vol. 82, pp. 2040-2044.
- Xu, C-l. and Guo, B-y. (2002). Laguerre pseudospectral method for non-linear partial differential equations, *Journal of Computational Mathematics*, 20, pp. 413-428.
- Chiam, T. C. (1997). Magnetohydrodynamic heat transfer over a non-isothermal stretching sheet, *Acta Mech.*, Vol. 122, pp. 169-179.
- Cortell, R. (2005). Flow and heat transfer of a fluid through a porous medium over a stretching surface with internal heat generation/absorption and suction/blowing, *Fluid Dynamics, Resources*, Vol. 37, pp. 231-245.
- Crane, L. J. (1970). Flow past a stretching plate, *Z. Angew. Math. Phys.*, Vol. 21, pp. 645-647.
- Elbashbeshy, E. M. A. and Bazid, M. A. A. (2004). Heat transfer in a porous medium over a stretching surface with internal heat generation and suction or injection, *Applied Mathematics and Computation*, Vol. 158, pp. 799-807.
- Elbashbeshy, E. M. A. and Dimian, M. F. (2002). Effects of radiation on the flow and heat transfer over a wedge with variable viscosity, *Applied Mathematics & Computation*, Vol. 132, pp. 445-454.
- Fang, T., Zhang, J. and Zhong, Y. (2012). Boundary layer flow over a stretching sheet with variable thickness, *Applied Mathematics and Computation*, Vol. 218, pp. 7241-7252.
- Grubka, L. J. and Bobba, K. M. (1985). Heat transfer characteristics of a continuous stretching surface with variable temperature, *Journal of Heat Transfer*, Vol. 107, pp. 248-250.
- Gupta, P. S. and Gupta, A. S. (1979). Heat and mass transfer on a stretching sheet with suction or blowing, *Canadian Journal Chem. Eng.*, Vol. 55, No. 6, pp. 744-746.
- Hayat, T., Abbas, Z. and Javed, T. (2008). Mixed convection flow of a micropolar fluid over a non-linearly stretching sheet, *Physics Letter A*, Vol. 372, pp. 637-647.
- Hayat, T., Abbas, Z., Pop, I. and Asghar, S. (2010). Effects of radiation and magnetic field on the mixed convection stagnation-point flow over a vertical stretching sheet in a porous

- medium, *International Journal of Heat and Mass Transfer*, Vol. 53, pp. 466-474.
- Hossain, M. A., Alim, M. A. and Rees, D. (1999). The effect of radiation on free convection from a porous vertical plate, *Int. Journal of Heat Mass Transfer*, Vol. 42, pp. 181-191.
- Khader, M. M. (2011). On the numerical solutions for the fractional diffusion equation, *Communications in Nonlinear Science and Numerical Simulation*, Vol. 16, pp. 2535-2542.
- Khader, M. M. (2014). Laguerre collocation method for the flow and heat transfer due to a permeable stretching surface embedded in a porous medium with a second order slip and viscous dissipation, *Applied Mathematics and Computation*, Vol. 243, No. 15, pp. 503-513.
- Khabibrakhmanov, I. Z. and Summers, D. (1998). The use of generalized Laguerre polynomials in spectral methods for non-linear differential equations, *Computers Mathematics with Application*, Vol. 36, pp. 65-70.
- Khader, M. M., Talaat, S. El Danaf and Hendy, A. S. (2013). A computational matrix method solving systems of high order fractional differential equations, *Applied Mathematical Modelling*, Vol. 37, pp. 4035-4050.
- Khader, M. M., Sweilam, N. H. and Mahdy, A. M. S. (2013). Numerical study for the fractional differential equations generated by optimization problem using Chebyshev collocation method and FDM, *Applied Mathematics and Information Science*, Vol. 7, No. 5, pp. 2013-2020.
- Mahmoud, M. A. A. and Megahed, A. M. (2009). MHD flow and heat transfer in a non-Newtonian liquid film over an unsteady stretching sheet with variable fluid properties, *Canadian Journal of Physics*, Vol. 87, pp. 1065-1071.
- Pedro, J. C., Banda, M. K. and Sibanda, P. (2015). Implicit-explicit higher-order time integration schemes for computations of structural dynamics with fluid-structure interaction, *Applications and Applied Mathematics*, pp. An International Journal, Vol. 10, No. 1, pp. 287-311.
- Pedro1, J. C., Banda, M. K. and Sibanda, P. (2015). Implicit-explicit higher-order time integration schemes for computations of structural dynamics with fluid-structure interaction, *Applications and Applied Mathematics: An International Journal*, Vol. 10, No. 1, pp. 287-311.
- Raptis A. (1998). Flow of a micropolar fluid past a continuously moving plate by the presence of radiation, *Int. J. Heat Mass Transfer*, Vol. 41, pp. 2865-2866.
- Raptis A. (1999). Radiation and viscoelastic flow, *Int. Commu., Heat Mass Transfer*, Vol. 26, pp. 889- 895.
- Soundalgekar, V. M. and Ramana, T. V. (1980). Heat transfer past a continuous moving plate with variable temperature, *Warme-Und Stoffubertragung*, Vol. 14, pp. 91-93.
- Sweilam, N. H. and Khader, M. M. (2010). A Chebyshev pseudo-spectral method for solving fractional order integro-differential equations, *ANZIAM*, Vol. 51, pp. 464-475.
- Sweilam, N. H., Khader, M. M. and Mahdy, A. M. S. (2012). Numerical studies for fractional-order Logistic differential equation with two different delays, *Journal of Applied Mathematics*, Vol. 2012, pp. 1-14.
- Sweilam, N. H., Khader, M. M., and Mahdy, A. M. (2012). Numerical studies for solving fractional Riccati differential equation, *Applications and Applied Mathematics: An International Journal*, Vol. 7, No. 2, pp. 1-10.

Talay Akyildiz, F., (2009). Laguerre spectral approximation of Stokes first problem for third-grade fluid, *Journal of Computational Mathematics*, Vol. 10, pp. 1029-1041.