

# TRAINING FUTURE ENGINEERS IN CONDITIONS OF EDUCATIONAL AND INFORMATION ENVIRONMENT OF A TECHNICAL UNIVERSITY

## AUTHORSHIP

### Vitaliy Rakhmanov

Doctor of Pedagogical Sciences, Associate Professor, Professor of the Department of Pedagogy and Psychology of Professional Education, National Aviation University, Kyiv, Ukraine.

**ORCID:** <https://orcid.org/0000-0002-7180-4087>

**E-mail:** [vitaliyakhmanov@nau.edu.ua](mailto:vitaliyakhmanov@nau.edu.ua)

### Myroslav Koval

Doctor of Pedagogical Science, Professor, Rector of the Lviv State University of Life Safety, Lviv, Ukraine.

**ORCID:** <https://orcid.org/0000-0002-0662-862X>

**E-mail:** [lviv-koval@ukr.net](mailto:lviv-koval@ukr.net)

### Andrii Lytvyn

Doctor of Pedagogical Science, Professor, Professor of the Department of Practical Psychology and Pedagogy, Lviv State University of Life Safety, Lviv, Ukraine.

**ORCID:** <https://orcid.org/0000-0002-7755-9780>

**E-mail:** [avlytvyn@gmail.com](mailto:avlytvyn@gmail.com)

### Myroslava Kusiy

Ph.D. in Pedagogy, Associate Professor, Associate Professor of the Department of Applied Mathematics and Mechanics, Lviv State University of Life Safety, Lviv, Ukraine.

**ORCID:** <https://orcid.org/0000-0003-3120-1975>

**E-mail:** [kusijmiroslava@gmail.com](mailto:kusijmiroslava@gmail.com)

### Inna Snitsar

Ph.D. in Pedagogy, Associate Professor, Associate Professor of the Department of foreign languages, Khmelnytsky National University, Khmelnytskyi, Ukraine.

**ORCID:** <https://orcid.org/0000-0003-0602-2166>

**E-mail:** [inna-sordo2012@ukr.net](mailto:inna-sordo2012@ukr.net)

### Georgii Artiushyn

Doctor of Pedagogical Science, Professor, Head of the Department, Educational and Scientific, Institute of Retraining and Advanced Training of Personnel of the Security Service of Ukraine, Kyiv, Ukraine.

**ORCID:** <https://orcid.org/0000-0002-3231-3664>

**E-mail:** [arteg0973@gmail.com](mailto:arteg0973@gmail.com)

**Received in:**

2021-05-10

**Approved in:**

2021-07-20

**DOI:** <https://doi.org/10.24115/S2446-622020217Extra-B1153p.641-654>

## INTRODUCTION

One of the strategic goals of higher education in the context of globalization is to promote the sustainable development of national societies and economies in the countries of the world by training competitive human capital and creating conditions for the professional development of a specialist's personality throughout life. In this regard, there is a need to find new, more effective approaches to the organization of the educational process in educational institutions. Training of future engineers in technical universities is of particular importance, since the design and implementation of products and software for automating various processes depend on the specialists in this specialty, and it has a high added value and impact on the development of the economy.

The results of generalization of scientific publications on the problem of improving the quality of engineering training (RAKHMANTOV, 2016; FOWLER et al., 2002; TUVI-ARAD and NAC HMIAS, 2003) allow us to state that modern socio-economic processes of society development put forward specific requirements for systemic, interdisciplinary knowledge of future engineers, necessary for rational understanding of growing volumes of scientific and technical information in order to solve new, non-standard production problems (BYKOV, 2005). The solution of this goal involves the implementation of a number of educational tasks, namely: providing conditions for training future specialists, expanding opportunities for the

implementation of knowledge in practice; activating cognitive activity for learning, taking into account the level of individual development of the individual and motivating it to self-education.

Training of future engineers in technical universities requires improvement, which determines the search for new models, technologies, methods, forms, approaches and methods of teaching in higher education institutions. Among the theoretical and methodological problems of training future specialists, special attention is paid to the creation of new conceptual approaches to the development and implementation of modern teaching methods and tools in the educational process, solving a complex of scientific problems related to the development of computer-oriented, information and communication tools and training systems, determining their pedagogical capabilities, methods of integrated use in the educational process.

Solving the scientific problem of improving the quality of education of future engineering specialists involves clarifying the essence and content of the concepts of "environment",

"educational environment", "educational and information environment". In particular, the scientist GLAZUNOV (2012) in his publications considered the creation of a reflexive and innovative environment, where university environment is one of the factors of the educational process, which allows in a short period of time to solve the problems of intensive formation and development of abilities necessary for the implementation of professional development. This allows to achieve optimal realization of the creative potential of individual in life and professional activities, and facilitates personal and professional growth, developing and correcting various human changes.

Researcher Litvinenko (2013) notes that the scientific and methodological environment has two components - internal and external. Factors of the internal environment operate in the immediate environment - inside the methodological office (center). Environmental factors (for example, the Ministry of Education and Science of Ukraine) - affect the effectiveness and efficiency of a scientific and methodological institution from the outside. The institution of Higher Education implements the principle of coordination of the activities of the educational management bodies and the methodological service, mainly through planning and coordination of joint actions (LITVINENKO, 2013). The researcher in her work considers the scientific and methodological environment as one of the elements of the educational environment. One cannot disagree with this.

Scientists Wu and Chiang (2013) point out that recently there have been diffusion processes, when there is an interpenetration of the functions of educational management bodies, and education departments (management) have the functions of methodological offices, without violating legal and statutory norms. In addition, at this level, the vector of efforts of employees of the methodological office (initiative, desire to improve the system, help the teacher) is directed to coordinate the activities of scientific and methodological structures of various levels, methodological measures in the institution of higher education, dissemination of pedagogical experience, professional development and promotion of self-education of teachers (WU and CHIANG, 2013). The scientist considers auxiliary elements of the educational environment that are useful for forming a powerful educational space.

Researchers Didenko, Androshchuk, Balendr et al., (2021), Soroka et al. (2020), Balendr et al. (2021) consider the concept of an information and educational environment as one where information interaction is ensured, which is aimed at meeting the educational and professional needs of future specialists provided by special hardware and software tools.

Certain aspects of the functioning of the educational and information environment were the subject of attention of the scientific community (SHUMOVETSKA et al. 2021; BALENDR et al, 2019a, 2019b). However, the results of the study on the specifics of training future engineering specialists in the educational and information environment of a technical university require publication, since such studies have not been conducted before. The relevance of solving the scientific problem is due to the fact that the educational and information environment ensures the formation and development of future engineering specialists' ability to solve professional problems of various levels of complexity.

Given this the purpose of the article is to present the results of a study on the specifics of training future engineering specialists in the educational and information environment of a technical university, as well as methodological recommendations formulated on the basis of the results obtained.

## RESEARCH METHODS

Conducting research on the formation of the educational and information environment of a technical university and, as a result, improving the quality of training of future engineers at a technical university, provided for the use of a number of methods - theoretical, empirical and mathematical statistics methods.

Among the theoretical methods, the research uses a conceptual and comparative analysis of scientific literature, a method of systemically structured analysis of curricula, plans, educational documents of a higher education institution, as well as modeling of learning processes and technologies for constructing the content of academic disciplines. The use of

these methods provided justification for pedagogical conditions designed to improve the quality of training of future engineers in the educational and information environment.

To obtain quantitative values regarding the results of training future engineers in the educational and information environment, the survey method was used. The tools of this method are an oral and written survey of students, testing, self-assessment using test tasks, performing practical tasks and projects. In order to study the state of professional training in the educational and information environment, to find out the difficulties that arise in the learning process using information systems, a survey of teachers was conducted.

The study also used mathematical statistics methods and SPSS application programs to interpret the obtained experimental data, compare samples, determine reliability, assess the significance of differences, and conduct correlation and variance analysis.

In order to obtain information on the effectiveness of the proposed methodological recommendations for the formation of the educational and information environment of a technical university, as well as the quality of training of future engineers in the educational and information environment of a technical university, a formative experiment was conducted. It had a comparative character: two pedagogical training systems (two educational and information environments) were compared - the author's one (developed on the basis of theoretical analysis and research results of the traditional practice of training future engineering specialists) and the traditional one. In order to compare these systems, experimental (EG) and control (CG) groups of future engineers were created, which were trained according to the author's and traditional didactic systems, respectively. At the beginning of the experiment, EG and CG were identical groups in both academic performance and attitude to future professional activities.

Measuring and comparing the training results of future engineers involved using a three-level scale, in which the lowest level was considered reproductive, the average - productive, and the highest - creative.

## RESEARCH RESULTS

The study of the formation of an educational and information environment, the functioning of which in a technical university will contribute to improving the quality of training of future engineers, provided for testing the hypothesis. It is based on assumptions with the following key aspects (author's pedagogical conditions):

- the educational and information environment of a technical university should be designed as an open dynamic and synergistic system;
- future engineers at the technical university should be provided with the opportunity to actively participate in the design of the educational process with the subsequent implementation of a training system based on individual educational trajectories and the use of educational and information resources, taking into account the individual psychological capabilities of students;
- the educational and informational environment of a technical university should contribute to a positive internal motivational focus on creative educational activities of students and an atmosphere of mutual trust and demands on the formation of common goals and interests;
- the effectiveness of the educational and information environment of a technical university depends on: the level of interdisciplinary integration in the process of educational activities aimed at developing future engineers' creative abilities; the use of interactive teaching methods by teaching staff to activate cognitive activity; attracting future engineers to independent, professionally-oriented training;
- the functioning of the educational and information environment depends on the ability of teachers to create e-learning courses;
- the formation of the educational and information environment of a technical university is carried out on the basis of a combination of personal-activity,

deterministic, stochastic, competence, cybernetic, integrated, technological, technocratic and system-synergetic methodological approaches.

During the study, these pedagogical conditions were implemented. In particular, in the experimental groups, the sequence of teaching professional disciplines was changed, but the total amount of theoretical and practical material remained unchanged. In order to find out the effectiveness of the author's educational and information environment and its impact on the quality of training of future engineers, the results of their success were constantly recorded. For this purpose, intermediate tests were conducted, which: determined the level and quality of mastering by the future engineers of professional competencies; characterized changes in academic performance, attitude to the future profession, the level of independent cognitive activity and motivation to learn. Generalization of the obtained learning results in three disciplines ("Technology of structural materials", "Theoretical mechanics", "Theory of machines and mechanisms") is presented in Table. 1, which indicates that as the result of introduction of an experimental technique, the level of knowledge of future engineers and the development of abilities in studying disciplines improves.

The study found that students - future engineers, independently chose their individual learning trajectory in accordance with the curriculum. Monitoring the quality of training provided for knowledge control. If the future engineer successfully passed a modular test paper (exam), he was graded by modular current assessment (the level of competence of the future specialist corresponds to the ECTS). If positive results were obtained, the student was allowed to learn new knowledge. If the student received a negative result based on the results of the knowledge control (failed to complete the task - the level of competence of the future specialist is lower than the level of knowledge according to ECTS), then he was asked to review material using feedback (fig. 1).

Fig. 1. Scheme for using positive and negative feedback

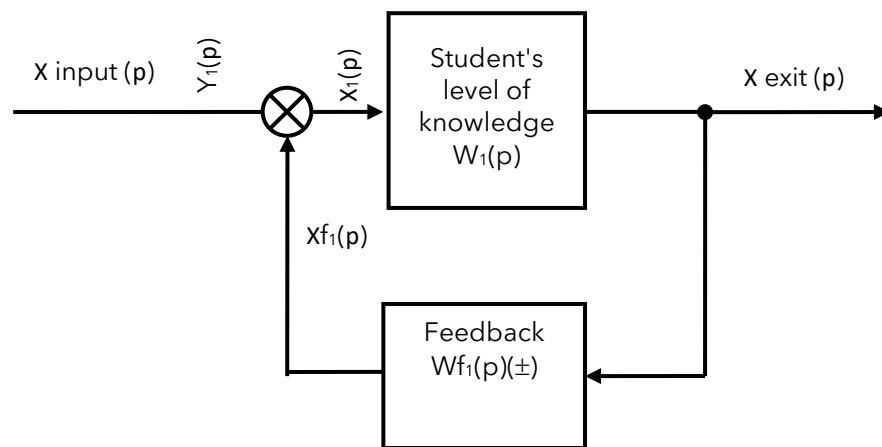

Source: Search data.

At the same time, the level of training of future engineers was compared taking into account the established educational standards. Feedback allowed to consolidate what was done correctly and helped us draw up an action plan to correct errors where there is an objective standard. If a future engineer has worked out the theoretical material he has studied in practice, he should have information that would confirm the correctness or fallacy of his actions.

The concept of "feedback" came to pedagogy in the 60s of the last century from cybernetics, the science of managing complex dynamic systems that can perceive, store and process information, and use it for management. Feedback as a phenomenon of cybernetics was first discussed by the American scientist Norbert Wiener, who believed that thanks to the organization of feedback, it becomes possible to implement activity, selectivity of interaction, which is a condition for the stability of the system and leads it to an ordered state: "...

wherever we consider control processes, in a living organism or in their community, in machines or in society, nowhere can they be carried out without feedback" (SPIRIN, 2009).

Based on the fact that the processes and systems studied by cybernetics have a number of features that are also characteristic of human activity and behavior, the concepts and methods of cybernetics can, in a certain way, be used to model and study some aspects of pedagogical and psychological processes (YEVTUKH, KULIK, LUZIK, 2012). In particular, learning can be considered as regulating the development of the personality who is learning by purposefully managing his or her activities and behavior.

In the study, the effective functioning of the educational and information environment of a technical university provided for the implementation of a cyclical type of management, when the management system receives data on the progress of the process and can provide feedback and correction. With a different type of control – open, there is no feedback or correction. Cyclical type of management provides for compliance with certain requirements: allocation of the object (process) of management; constructive indication of the purpose of management; establishment of the initial state of the managed object; development of an action program taking into account the main transition states of the managed object; systematic receipt of information about the state of the managed object, that is, providing systematic feedback; analysis of information received through the feedback channel; development on the basis of this information of actions that ensure correction (regulation), and their implementation. These requirements involve the development of two types of management programs: basic and corrective. The first one is developed before the start of the management system; the second one is developed both before and during the management process. Based on these provisions of cybernetics, the study took into account a number of important aspects: the stages of knowledge acquisition by students were determined by the transition states of the objects that were diagnosed; the training program for future engineers within the educational and information environment ensured the consistency of all stages of training; a system of characteristics of control (monitoring) over the course of assimilation of educational material was established. This provided systematic feedback in training.

Information about monitoring the assimilation of educational information was available to teachers (management system) and future engineers (managed system). This provided external (information goes to the teacher) and internal (information goes to the future engineer) feedback. At the same time, internal feedback was provided both with the help of software and with the help of self-monitoring (ANTONENKO, NIEDERHAUSER, 2010).

It is important to note that knowledge control also provided regulation of the motivation of students' cognitive activity, as well as the level of consolidation of their knowledge and skills. As for motivation, this can be explained as follows: if the future engineer is confident in the correctness of his activity and it is successful, then additional information about the learning process will distract him, which can lead to a decrease in learning motivation. Conversely, if the future engineer is not sure of the correctness of his actions, if they are correct, the teacher should provide information about the change in the course of the process. In this case, confirming the correctness of their actions causes a sense of satisfaction of a future engineer, increases his desire to learn further and contributes to the satisfaction of the actions performed.

According to the provisions of cybernetics, the regulation of the process of mastering competencies can be carried out by responding to expected situations, changes that have occurred, mistakes. The conducted knowledge control, due to feedback, allows you to make corrections when it turns out to be necessary in the learning process, namely, timely correction allows to avoid deviations from the controlled learning process.

During the study, changes occurred in the educational process, the progress of current work was analyzed, corrective decisions were made, the current control of knowledge of future engineers was evaluated, etc. That is why feedback is understood as a reflection of knowledge, which helps a future engineer to determine whether the information presented has been learned or not (SPIRIN, IVANOVA, YATSISHIN, KILCHENKO, 2017), and gives a teacher the opportunity to obtain and analyze students' knowledge. The ability to use the

feedback tool is one of the main skills of a teacher, which allows to more accurately determine the level of knowledge of future engineers, and in the future positively influence training. Feedback helps the teacher determine an effective strategy and tactics of the educational process, as well as correct them in time. To analyze the efficiency of using feedback, we present mathematically the following relations (POPOVICH and KOVALCHUK, 2007), which reflect:

$$\begin{cases} X_{exit}(p) = W_1(p)X_1(p); \\ X_{f_1}(p) = W_{f_1}(p)X_{exit}(p); \\ X_1(p) = Y_1(p)X_{f_1}(p). \end{cases} \quad (1)$$

where,

- $X_{exit}(p)$  - effectiveness of initial knowledge;
- $W_1(p)$  - the student's level of preparedness;
- $X_1(p); Y_1(p)$  - external influences;
- $X_{f_1}(p)$  - output feedback parameters;
- $W_{f_1}(p)$  - feedback.

If you exclude intermediate variables  $X_1(p)$  and  $X_{f_1}(p)$ , we'll get:

$$X_{exit}(p) = W_1(p)[Y_1(p) + W_{f_1}(p)X_{exit}(p)]. \quad (2)$$

From relation (2) follows:

$$X_{exit}(p) = \frac{W_1(p)}{1 - W_1(p)W_{f_1}(p)} Y_1(p). \quad (3)$$

If the assimilation of knowledge by future engineers coincides with the sign of current knowledge, then the feedback is positive. In this case, the transfer function of the knowledge acquisition chain covered by positive feedback is equal to:

$$W(p) = \frac{X_{exit}(p)}{Y_1(p)} = \frac{W_1(p)}{1 - W_1(p)W_{f_1}(p)}. \quad (4)$$

Otherwise, a negative value is of the feedback is used:

$$W(p) = \frac{X_{exit}(p)}{Y_1(p)} = \frac{W_1(p)}{1 + W_1(p)W_{f_1}(p)}. \quad (5)$$

If the assimilation of information by a future engineer is determined by the proportionality of the level of assimilation of knowledge, we have positive hard feedback ( $W_{hf_1}(p)$ ) (Fig. 2).

For example the level of knowledge of a future engineer is equal to the ratio of the coefficient

$$W_1(p) = \frac{k}{p},$$

of assistance to the regulation of knowledge and the knowledge feedback is equal to the feedback gain  $W_{f_1}(p) = kf$ , then:

$$W_{hf_1}(p) = \frac{\frac{k}{p}}{1 - \frac{k}{p}kf} = \frac{\frac{1}{k_f}}{\frac{1}{k \cdot kf}p - 1} = \frac{k}{Tp - 1}, \quad (6)$$

Figure 2. Block diagram of the functioning of feedback links of the educational and information environment of a technical university

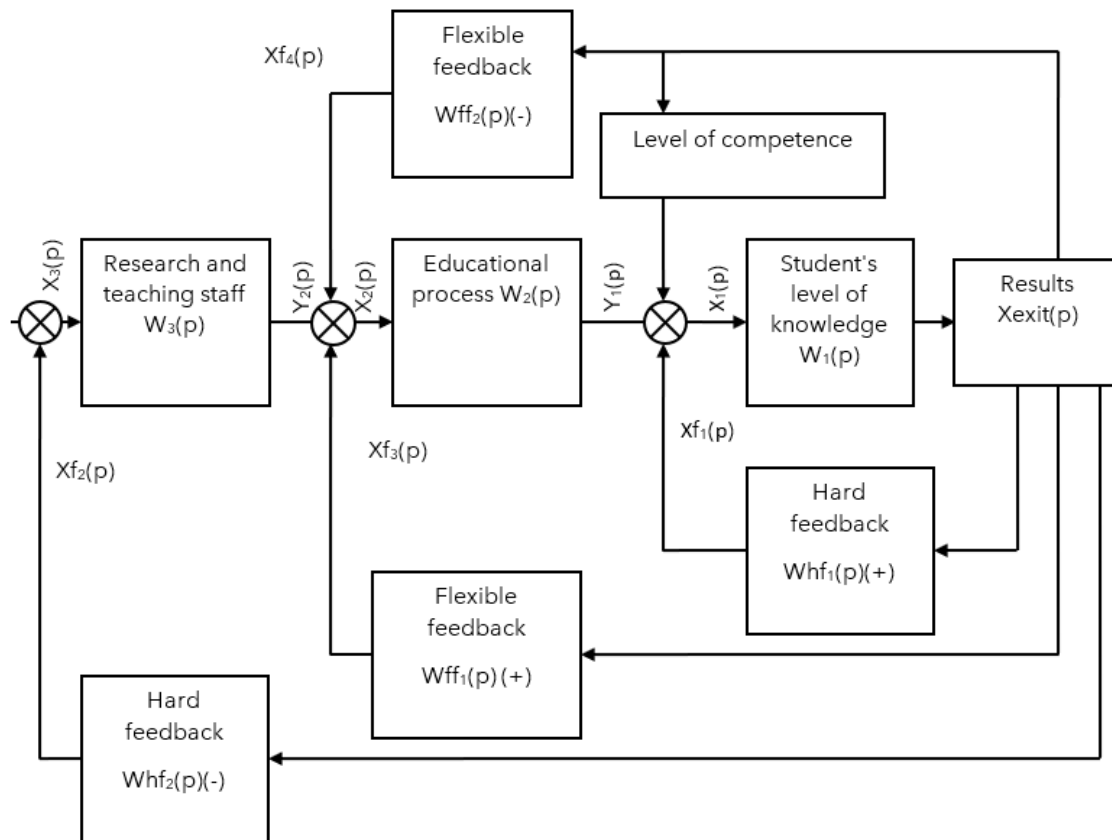

Source: Search data.

when the integrating link of positive hard feedback is covered we get an unstable link with a gain factor  $k = \frac{1}{k_f}$  and sustainable time  $T = \frac{1}{k \cdot k_f}$ .

For optimal assimilation of knowledge, if the future engineer easily copes with the task (the level of competence of the future specialist is higher than the ECTS level) or, conversely, it is difficult for the student to re-assimilate the educational material (the level of competence of the future specialist is lower than the ECTS level), then negative hard feedback is used  $Whf_2(p)$ , that is, the information program in the educational and information environment is configured in such a way that the future engineer is provided with more complex educational material or simplified, respectively (RAKHMANOV, 2014). Let's describe this algorithm mathematically in the form:

$$W_{hf_2}(p) = \frac{\frac{k}{p}}{1 + \frac{k}{p}k_f} = \frac{\frac{1}{k_f}}{\frac{1}{k \cdot k_f}p + 1} = \frac{k}{Tp + 1} \tag{7}$$

Depending on the level of training of the students, while delivering new educational material, it is suggested to provide new information at a fast or slow pace, then positive flexible feedback is used  $Wff_3(p)$ , which takes the form:

$$W_{ff_1}(p) = \frac{\frac{k}{p}}{1 - \frac{k}{p} k_f \cdot p} = \frac{\frac{k}{1 - k \cdot k_f}}{p} = \frac{k}{p} \quad (8)$$

When  $\frac{k}{1 - k \cdot k_f} > k$  - a link of positive flexible feedback, where  $p$  - regulatory element of knowledge, and  $k$  - coefficient of assistance.

In addition, in the process of professional training of a future engineer, changes may occur in the educational process due to the implementation of orders (messages) of the Ministry of Education and Science of Ukraine regarding optimization of the educational process, introduction of the latest training system, etc., then negative flexible feedback is used  $W_{ff_2}(p)$ .

$$W_{ff_2}(p) = \frac{\frac{k}{p}}{1 + \frac{k}{p} k_f \cdot p} = \frac{\frac{k}{1 + k \cdot k_f}}{p} = \frac{k}{p} \quad (9)$$

where  $\frac{k}{1 + k \cdot k_f} < k$  - negative flexible feedback link.

When covered by flexible feedback, the knowledge link remains integrative, but the gain changes (SPIRIN and GOLOVNIA, 2018).

So, feedback is a key component of the future engineer's personality development, which not only helps the future specialist correct their mistakes before they become known, but also strengthens the acquired knowledge, stimulates professional development and helps future engineers achieve their study goals. The use of feedback through information and communication technologies makes it possible to establish favorable conditions for learning and overcoming difficulties (SPIRIN, 2010).

## RESEARCH RESULTS

The study involved future engineers of the first year of study of the educational degree "Master", who studied at the National Aviation University (Kyiv), in particular at the Educational and Scientific Institute of Aeronautics (specialty 8.05080102 "Physical and Biomedical Electronics" and specialty 8.05080201 "Electronic Devices and Equipment"), at the Educational and Scientific Aerospace Institute (Specialty 8.05110101 "Aviation, Rocket and Space Technology"), at the Educational and Scientific Institute of Computer Science Information Technologies (specialty 8.091501 "Computer Systems and Networks"). In the process of training future engineers in the educational and information environment, the level of cognitive capabilities of each student was taken into account. For this purpose, at the stage of ascertaining and control experiments, the level of readiness of each future engineer was determined using the example of three academic disciplines: "Technology of structural materials", "Theoretical mechanics", "Theory of machines and mechanisms". These results are presented in Table. 1. They show that as a result of the introduction of an experimental methodology for the formation of the educational and information environment of a technical university, the level of knowledge of future engineers and the development of their competencies significantly improves.



**Table 1.** Dynamics of the formation of competencies of future engineers in the control and experimental groups at the beginning (ascertaining experiment) and at the end (control experiment) of the study (in %, n=320)

Academic disciplines	Ascertaining experiment						Control experiment					
	Control group (n=79)			Experimental group (n=81)			Control group (n=82)			Experimental group (n=78)		
	Reproductive	Productive	Creative	Reproductive	Productive	Creative	Reproductive	Productive	Creative	Reproductive	Productive	Creative
Technology of structural materials	43.1	35.3	21.6	44.7	32.2	23.1	41.8	35.9	22.3	9.2	31.3	59.5
Theoretical mechanics	39.1	36.7	24.2	34.5	40.2	25.3	40.4	34.9	24.7	6.7	30.5	62.8
Theory of machines and mechanisms	40.8	36.1	23.1	39.1	38.5	22.4	39.7	39.5	20.8	7.4	29.2	63.4
Average value	41.0	36.0	23.0	39.4	37.0	23.6	40.6	36.8	22.6	7.8	30.3	61.9

Source: Search data.

The results of the exit level (control stage) of assimilation of knowledge and competencies of future engineers allowed us to draw conclusions about the optimal selection of study information not only for its successful assimilation of educational material in the academic disciplines "Technology of structural materials", "Theoretical mechanics", "Theory of machines and mechanisms" (fig. 3), but also further improvement of educational and professional programs. During the study, changes in the parameters of assimilation of knowledge, skills and abilities of future engineers were monitored, generalizations and intermediate analysis of the results obtained were made, and adjustments were made to the course of the study.

**Fig. 3.** Dynamics of the formation of competencies of future engineers in the control and experimental groups at the beginning (ascertaining experiment) and at the end (control experiment) of the study

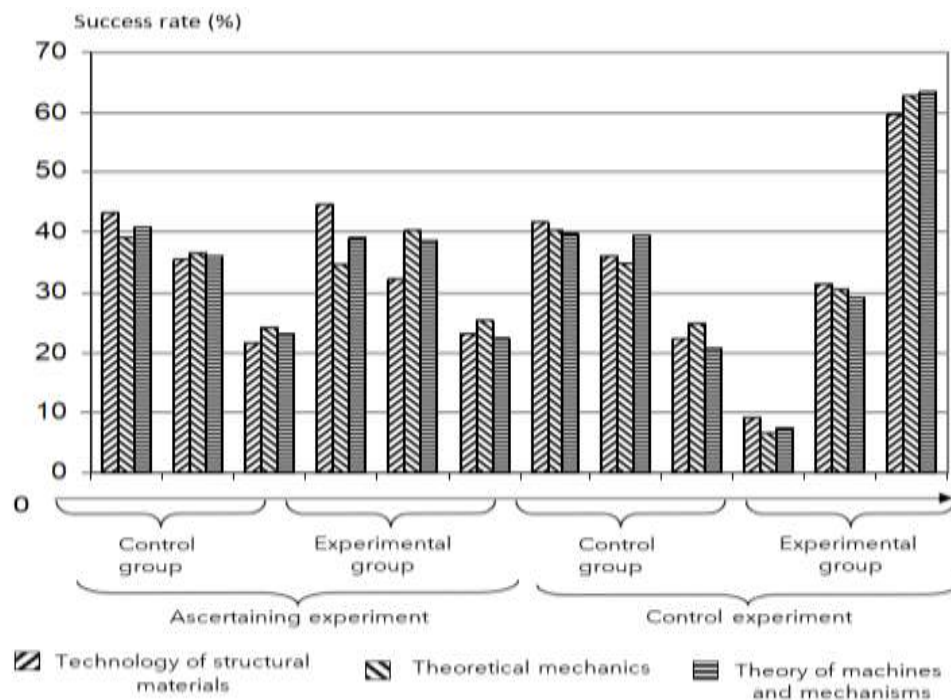

Source: Search data.

The implementation of training of future engineers of the experimental group in the educational and information environment, where feedback was provided at all stages of training, turned out to be a positive incentive and a means of better assimilation of educational material. Teachers who participated in the study note the students' attentiveness, diligence in meeting the requirements of the educational process, and the desire to better understand the educational material. The full functioning of the educational and information environment of the technical university ensures the active participation of future engineers in the implementation of an individual learning trajectory.

It is also worth noting the positive impact of systematic feedback, implemented in the process of functioning of the educational and information environment of the technical university, regarding the strength of knowledge, the quality of skills and abilities of future engineers. The positive reinforcement that each student received in the learning process increased confidence in the correctness of their actions and created internal incentives for active educational cognitive activity. At every stage of the educational process, future engineers had a clear idea of what they knew and didn't know.

It is also worth noting that the academic performance of students in the experimental group has improved. The results of the analysis of the data obtained in the study allow us to conclude that this is one of the consequences of the activities of teachers who systematically analyzed the educational activities of students in the educational and information environment. This allowed them to see which of the future engineers needed help and what exactly. Additional consultations were held with such students.

The results of the study on training future engineers in the educational and information environment of a technical university allow us to formulate certain methodological recommendations. In particular, it seems appropriate and important to carry out constant objective monitoring of the assimilation of educational material by future engineers; to implement a cyclical type of management of collective, individual and independent educational activities of students; to stimulate daily preparation for knowledge and activate the cognitive activity of each future engineer throughout the lesson, semester, etc.; to identify, eliminate gaps and errors in knowledge of future engineers in a timely manner; to check how future engineers have mastered each share of new material and, depending on this, to build its further delivery; to give reinforcement for each answer to all future engineers; to increase the productivity of teachers and intensify training activities of future engineers.

It is also important to note that learning in an educational and information environment gives the best results if educational tasks for students simultaneously implement reproductive, productive, creative levels of knowledge assimilation; direct the assimilation of knowledge by logically solving a particular cognitive task; make it possible (for example, according to intermediate results) to carry out independent assimilation of educational information, to form the necessary competencies.

According to the results of the control experiment, the training of future engineers in the educational and information environment does not violate the structure of classes but intensifies and diversifies the educational process and positively affects the student's personality: thus, a student forms and develops such qualities as attentiveness, the habit of constantly checking his answer and relying on his own strength. Based on the results of the study, it can be concluded that the training of future engineers in the educational and information environment of a technical university is more effective if:

- 1) future engineers perform more exercises of the creative (highest) level of difficulty;
- 2) programs-task are an addition to the teacher's explanation and educational material, which provides active cognition;
- 3) the future engineer immediately after mastering the theoretical material, reproduces and fixes it in practice (answers questions, solves problems, performs practical actions);
- 4) the results of the future engineer's practical activities are recorded and he immediately receives reinforcement regarding the correctness of his actions.

The results of the study also allow us to conclude that automated feedback opens up additional opportunities, compared to traditional control, in order to implement:

- 1) problem-based learning and problem-based delivery of educational material;
- 2) elements of programmable learning;
- 3) algorithmization of the material, its systematization and generalization;
- 4) attracting cognitive activity when solving problems and performing exercises, the ability to independently replenish one's knowledge;
- 5) management of both the process of perception and the process of assimilation of knowledge, which contributes to the understanding of mental actions, as well as the development of connections with previously acquired knowledge;
- 6) closed cycle of control and self-control.

## CONCLUSIONS

Generalization of the results of the research allows us to conclude that the implementation of the author's idea of training students in the educational and information environment of a technical university is one of the possible ways to overcome the existing contradictions in the training system - between the requirements for the level of professional competence of future engineers and the level of methodological and informational support of the educational process. The proposed model of professional training of future engineers in the educational and information environment of a technical university, based on the principles of taking into account feedback, allows improving the quality of training, speeding up the process of activating students' motives for cognitive activity and professional orientation of the individual. The maximum impact of the educational and information environment of a technical university on the quality of professional training of future engineers occurs if:

- this environment is designed as an open system that, along with the goals, content, principles, methods, means and forms of organizing the educational process, accumulates intellectual, cultural, software-methodological, organizational and technical resources (system management determines the goals of society, future engineers and teachers);
- future engineers are given the opportunity to actively participate in the design and further updating of individual educational learning trajectories when using educational and information resources and taking into account possible feedbacks, which provides a student-oriented approach to the organization of the educational process;
- the potential possibilities of the educational and information environment for the development of competencies, including the implementation of developmental training (integration, redundancy and multidimensional knowledge and activity components, openness of the system) are revealed and used;
- conscious and active participation of teachers in the formation of the educational and information environment through the creation of electronic training courses, when on the basis of their experience, knowledge, traditions, the content, general cultural component of the educational and information space is replenished (from the educational and information system of a certain educational institution to the Internet);
- training of future engineers is carried out on the basis of a system integration and a cybernetic approach to training and formed educational, scientific and organizational structures of the educational and information environment of a higher education institution. In the future, it is planned to consider the peculiarities of forming an educational and information environment in technical universities based on applied actions.

## REFERENCES

- ANTONENKO P. D.; NIEDERHAUSER D. S. The influence of leads on cognitive load and learning in a hypertext environment. *Computers in Human Behavior*, 2010, 26, p. 140-150. Available at: [https://www.researchgate.net/publication/223305833\\_The\\_influence\\_of\\_leads\\_on\\_cognitive\\_load\\_and\\_learning\\_in\\_a\\_hypertext\\_environment](https://www.researchgate.net/publication/223305833_The_influence_of_leads_on_cognitive_load_and_learning_in_a_hypertext_environment). Access: March 21, 2021.
- BALENDR, A.; BILETSKYI, V.; IAKYMCHUK, A.; SINKEVYCH, S.; KOROLOV, V.; BLOSHCHYNSKYI, I. Implementation of European Border Guards' Common Educational Standards in Ukraine: Comparative Analysis. *Romanian Journal for Multidimensional Education/Revista Romaneasca pentru Educatie Multidimensionala*, 2019a, 11 (2). Available at: <http://orcid.org/0000-0003-4610-2830>. Access: March 21, 2021.
- BALENDR, A.; KOMARNYTSKA, O.; BLOSHCHYNSKYI, I. Ukrainian border guards interoperability assessment in the framework of common European border guard standards implementation. *Advanced Education*, 2019b, 6 (12), p. 35-43. Available at: <https://doi.org/10.20535/2410-8286.128196> Access: March 21, 2021.
- BALENDR, A.; KOMARNYTSKA, O.; ISLAMOVA, O.; KHAMAZIUK, O.; LUSAN, P.; BILIAVETS, A. Online learning facilitation in foreign language training for border guards. *Laplace em Revista*, 2021, 202, 17 (2), p. 336-345. Available at: <https://doi.org/10.24115/S2446-6220202172743>. Access: April 29, 2021.
- BYKOV, V. Y. Theoretical and methodological foundations of modeling the educational environment of modern pedagogical systems. *Information technologies and teaching tools*. Collection of scientific works. Institute of teaching tools of the Academy of Pedagogical Sciences of Ukraine. Kyiv: Atika, 2005, 272, p. 5-15. Available at: <https://scholar.google.com/citations?user=MmNPAwYAAAAJ&hl=uk>. Access: March 21, 2021.
- GLAZUNOV, M. M. Criteria for evaluating the performance of the methodological service in the district (city), *Tauride Bulletin of Education*. Kherson, Ukraine, 2012, No. 2, p. 79-83. Available at: <https://drive.google.com/file/d/0B3AWUScdBCMFNIVHNEhaNWdXdEk/view?resourcekey=0-yz4rAcjzy21Y5D-EPw79w> Access: March 21, 2021.
- DIDENKO O. V.; ANDROSHCHUK, O. S.; MASLII, O. M.; BALENDR, A. V.; BILIAVETS, S. Y. Electronic educational resources for training future officers of border guard units. *Information Technologies and Learning Tools*, 2020, 80 (6), p. 39-57. Available at: <https://doi.org/10.33407/itlt.v80i6.3816>. Access: March 21, 2021.
- EVTUKH M. B.; KULIK M. S.; LUZIK E. V.; ILINA T. V. *Mathematical modeling in psychological and sociological research*. Kyiv, Ukraine: Information Systems LLC, 2012. Available at: <http://er.nau.edu.ua/handle/NAU/20326>. Access: March 21, 2021.
- FOWLER, L.; MCGILL, D.; ARMAREGO, J.; ALLEN, M. Quantitative learning conversations: Constructivism and its application to learning in an engineering environment, in quality conversations. *Proceedings of the 2002 Annual International Conference of the Higher Education Research and Development Society of Australia (HERDSA)*, Perth, Western Australia, 2002, 7-10 July, p. 254-262. Available at: [https://www.researchgate.net/publication/43980145\\_Quantitative\\_learning\\_conversations\\_Constructivism\\_and\\_its\\_application\\_to\\_learning\\_in\\_an\\_engineering\\_environment](https://www.researchgate.net/publication/43980145_Quantitative_learning_conversations_Constructivism_and_its_application_to_learning_in_an_engineering_environment). Access: March 21, 2021.
- LITVINENKO, G. Formation of a scientific and methodological environment: justification of the foundations and determination of criteria for the effectiveness of functioning. *Native school*, 2013, No 6. p. 57-63. Available at: [http://nbuv.gov.ua/UJRN/rsh\\_2013\\_6\\_14](http://nbuv.gov.ua/UJRN/rsh_2013_6_14) Access: March 21, 2021.
- MORENO, R. Decreasing cognitive load for novice students: effects of explanatory vs corrective feedback in discovery base multimedia educational psychology program. *Instructional Science*, 2004, V. 32, p. 99-113. Available at: <https://link.springer.com/article/10.1023/B:TRUC.0000021811.66966.1d>. Access: March 21, 2021.

SPIRIN, O. M.; IVANOVA, S. M.; YATSISHIN, A. V.; KILCHENKO, A. V. *Use of electronic open systems for information and analytical support of pedagogical research: a short terminology dictionary*, Kyiv: IITZN NAPN Ukrainy, 2017, 67p. Available at: <http://lib.iitta.gov.ua/707056>. Access: March 21, 2021.

SPIRIN O. M.; GOLOVNYA, O. S. Application of Unix-like operating system virtualization technologies in the preparation of bachelors in Computer Science, *Information Technologies and Learning Tools*, 2018, 3 (65), p. 201-222. Available at: <https://journal.iitta.gov.ua/index.php/itlt/article/view/2055/1349>. Access: March 21, 2021.

POPOVICH M. G.; KOVALCHUK, O. V. *Theory of automatic control: textbook. 2nd ed., processing. and doggie*. Moscow: Lybid publ., 2007, p. 656. Available at: [https://elprivod.nmu.org.ua/files/tac/Popovich\\_theoria%20authom%20keruv.pdf](https://elprivod.nmu.org.ua/files/tac/Popovich_theoria%20authom%20keruv.pdf). Access: March 21, 2021.

RAKHMANOV, V. O. Use of the educational and information environment in the process of studying humanities", *Bulletin of the National Aviation University. Series: Pedagogy. Psychology: Collection of scientific works*. Kyi, Ukraine: NAU, 2014, issue 5 (1), p. 113-117. Available at: <https://doi.org/10.18372/2411-264X.5.10155> Access: March 21, 2021.

RAKHMANOV, V. O. Methodological foundations of student training in the educational and information environment of a Technical University, *Science and Education a New Dimension. Pedagogy and Psychology*, 2016, IV (41), Issue: 86, p. 37-41. Available at: <https://www.slideshare.net/SocietyforCulturalan/science-and-education-a-new-dimension-pedagogy-and-psychology-issue-86-63859877> Access: March 21, 2021.

SHUMOVETSKA, S.; DIDENKO, O.; BOREICHUK, D.; BALENDR, A.; SNITSA, T. Pedagogical Conditions of Organizational Culture Formation of Future Border Guard Officers. *Postmodern Openings*, 2021, 12 (1Sup1), p. 75-88. Available at: <https://doi.org/10.18662/po/12.1Sup1/273>. Access: April 29, 2021.

SOROKA, O.; KALAU, S.; BALENDR, A. Monitoring of Corporate Culture Formation of Specialists of Social Institutions. *Postmodern Openings*, 2020, 11 (1Sup1), p. 218-233. Available at: <https://doi.org/10.18662/po/11.1sup1/131> Access: April 29, 2021.

SPIRIN, O. M. Information, Communication and computer competencies as components of the system of professional and specialized competencies of computer science teachers, *Information technologies and training tools*, 2009, No 5 (13). Available at: <http://ime.edu.ua/net/em.html>. Access: March 21, 2021.

TUVI-ARAD, I.; NACHMIAS, R. A study of web-based learning environments focusing on atomic structure. *Journal of Computers in Mathematics and Science Teaching*, 2003, V. 22, p. 225-240. Available at: <https://www.learntechlib.org/p/12790/>. Access: March 21, 2021.

VAN, GOG T.; PAAS, F.; MARCUS, N.; AYRES, P. The mirror neuron system and observational learning: implications for the effectiveness of dynamic visualizations. *Educational Psychology Review*, 2009, V. 21, p. 21-30. Available at: [https://www.researchgate.net/publication/226042599\\_The\\_Mirror\\_Neuron\\_System\\_and\\_Observational\\_learning\\_implications\\_for\\_the\\_Effectiveness\\_of\\_Dynamic\\_Visualizations](https://www.researchgate.net/publication/226042599_The_Mirror_Neuron_System_and_Observational_learning_implications_for_the_Effectiveness_of_Dynamic_Visualizations). Access: March 21, 2021.

WU, C.F.; CHIANG, M. C. Effectiveness of applying 2D static depictions and 3D animations to orthographic views learning in graphical course. *Computers & Education*, 2013, V. 63, p. 28-42. Available at: [https://www.researchgate.net/publication/257171384\\_Effectiveness\\_of\\_applying\\_2D\\_static\\_depictions\\_and\\_3d\\_animations\\_to\\_orthographic\\_views\\_learning\\_in\\_graphical\\_course](https://www.researchgate.net/publication/257171384_Effectiveness_of_applying_2D_static_depictions_and_3d_animations_to_orthographic_views_learning_in_graphical_course). Access: March 21, 2021.

## Training future engineers in conditions of educational and information environment of a technical university

Formação de futuros engenheiros em condições de educação e ambiente de informação de uma universidade técnica

Formación de futuros ingenieros en condiciones de entorno educativo y de información de una universidad técnica

### Resumo

O estudo apresenta os resultados da exploração da formação de futuros especialistas em engenharia nas condições de educação e ambiente de informação de uma universidade técnica, bem como recomendações metodológicas formuladas com base nos resultados obtidos. A pesquisa pressupõe que o ambiente educacional e de informação de uma universidade técnica deve ser projetado como um sistema dinâmico e sinérgico aberto, no qual futuros engenheiros devem ter a possibilidade de projetar uma trajetória educacional individual baseada no uso de recursos educacionais e informativos e considerando as capacidades psicológicas individuais dos alunos. O funcionamento do ambiente educacional e de informação de uma universidade técnica prevê um tipo cíclico de gestão da formação profissional de futuros especialistas e aderindo ao princípio do feedback na formação dos alunos. Os resultados do estudo, em especial uma comparação dos níveis de formação de competência de futuros engenheiros nos grupos de controle e experimentais no início e no final do estudo, confirmaram a correção da hipótese apresentada.

**Palavras-chave:** Formação profissional. Futuros engenheiros. Processo educacional. Ambiente educacional e de informação. Universidade técnica.

### Abstract

The study presents the results of exploring the training of future engineering specialists in the conditions of educational and information environment of a technical university, as well as methodological recommendations formulated on the basis of the results obtained. The research assumes that the educational and information environment of a technical university should be designed as an open dynamic and synergetic system, in which future engineers should be given a possibility to design an individual educational trajectory based on the use of educational and information resources and considering the individual psychological capabilities of students. The functioning of the educational and information environment of a technical university provides for a cyclical type of management of professional training of future specialists and adhering to the principle of feedback in student training. The results of the study, in particular a comparison of the levels of competence formation of future engineers in the control and experimental groups at the beginning and end of the study, confirmed the correctness of the hypothesis put forward.

**Keywords:** Professional training. Future engineers. Educational process. Educational and information environment. Technical university.

### Resumen

El estudio presenta los resultados de explorar la formación de futuros especialistas en ingeniería en las condiciones del entorno educativo y de información de una universidad técnica, así como recomendaciones metodológicas formuladas sobre la base de los resultados obtenidos. La investigación asume que el entorno educativo y de información de una universidad técnica debe ser diseñado como un sistema abierto dinámico y sinérgico, en el que los futuros ingenieros deben tener la posibilidad de diseñar una trayectoria educativa individual basada en el uso de recursos educativos y de información y considerando las capacidades psicológicas individuales de los estudiantes. El funcionamiento del entorno educativo y de información de una universidad técnica prevé un tipo cíclico de gestión de la formación profesional de los futuros especialistas y la adhesión al principio de retroalimentación en la formación de los estudiantes. Los resultados del estudio, en particular una comparación de los niveles de formación de competencias de los futuros ingenieros en los grupos control y experimental al principio y al final del estudio, confirmaron la corrección de la hipótesis presentada.

**Palabras-clave:** Formación profesional. Futuros ingenieros. Proceso educativo. Entorno educativo y de información. Universidad técnica.