

PAPER • OPEN ACCESS

The oil spills stopping device for oil pipelines

To cite this article: O N Petrov *et al* 2020 *J. Phys.: Conf. Ser.* **1515** 052046

View the [article online](#) for updates and enhancements.



IOP | ebooks™

Bringing together innovative digital publishing with leading authors from the global scientific community.

Start exploring the collection—download the first chapter of every title for free.

The oil spills stopping device for oil pipelines

O N Petrov, D V Agrovichenko*, A N Sokolnikov and V I Vereshchagin

Siberian Federal University, 82 Svobodny Avenue, Building 6, 660041, Krasnoyarsk, Russia

*E-mail: dagrovichenko@sfu-kras.ru

Abstract. Emergency oil spills during main pipeline transportation have an extremely negative impact on the ecosystem. It is not possible to estimate the effects of oil spills, because oil is a product of long period decay. Oil pollution compromises processes proceeding in the biosphere, changes the living conditions of living organisms and their interrelation. Oil spills need to be prevented for negative impact reduction or, in case of an accident occur, spill need to be stopped and consequences need to be eliminated in a short time. Accident prevention is achieved by observing the requirements and rules of engineering surveys and pipeline design. If the requirements of standards are complied with, the hydrogeological and climatic features of the district are considered during design, construction and operation, the pipeline should work without accidents during the service life. But accidents may occur as a result of human factors, natural calamities and other unexpected circumstances. Oil spill prevention is not simple and not standard task. For time and costs reducing universal tool for oil spill prevention needs to be invented. This tool needs to be used before temporary clamping structure will be installed.

The pipelines are designed in such a way that their operability is not violated during the service life. Nevertheless, leaks in pipeline networks are one of the main causes of many natural losses, serious environmental catastrophic, and human victims. Significant research efforts for pipeline leak detection and localization with different approaches were implemented for avoiding this threat and for safe and reliable pipeline infrastructure sustaining [1]. This article will focus on oil spill stopping technology from pipelines.

In [2], the situation with oil spills accidents in the sea is described, and then the consequences of these accidents are analyzed. The analysis showed that the sea oil spills occurred from time to time due to the human factor - negligence and because of pipeline design position changes and of its subsequent rupture. Accidents have had significant consequences for the economy, the aquatic environment, and human health. The experience of combating with the negative consequences of pipeline accidents in North America is discussed in the paper [3]. Technologies for eliminating pollution and assessment their impact on the environment are considered here. In [4], a historical analysis of accidents that occurred on pipelines is carried out to illustrate the risks associated with pipeline systems and the consequences of accidents. Evaluation of the effectiveness and cost of oil spill response technologies, as well as environmental impacts are given in articles [5-7]. The causes, consequences, prevention, and countermeasures are well described in Chapter 7 of «Fossil Fuels» [8].

The prevention of oil spills from the pipeline involves three stages. The first stage is the closure of line check valves (SP 36.13330.2012, GOST 24856-2014) in order to isolate the pipeline section. The



second stage is the breaking up of oil spill from the pipeline. The third stage is the prevention of liquid spreading on the surface.

According to SP 36.13330.2012 management of line check valves is carried out remotely and does not require any detailed discussion. Pipeline oil spill interruption or spill localization is the most difficult task, because it requires an individual approach and prompt selection of suitable tools. Oil spill prevention is the labour intensive process, but it is predictable and clear in the same time. This way in this job second stage is discussed namely oil spill stopping after accidents.

The line part defect temporary repair method is considered in RD 153-39.4-067-00. For B1 and B2 repair types temporary repair constructions is allowed. B1 – welded non-swaged anticorrosion liquid filled repair sleeve with technological rings. B2 – welded anticorrosion liquid filled repair sleeve with conical transitions (figure 1).

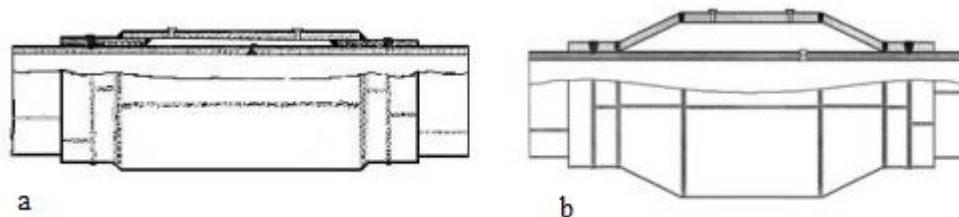

Figure 1. Repair constructions for temporary repair: a – type B1; b – type B2.

Using repair sleeves B1 and B2 types not allowed for schedule repair. These sleeves used for emergency repair and for corrugation repair with following mandatory replacement by permanent repair methods. Using these sleeves during the oil spills is a complicated task and some time may be impossible.

Consider the method of sealing defective areas according to the «crimping technology». Metal crimp sleeve (figure 2) allows us to localize the oil spill from the pipeline without welding.

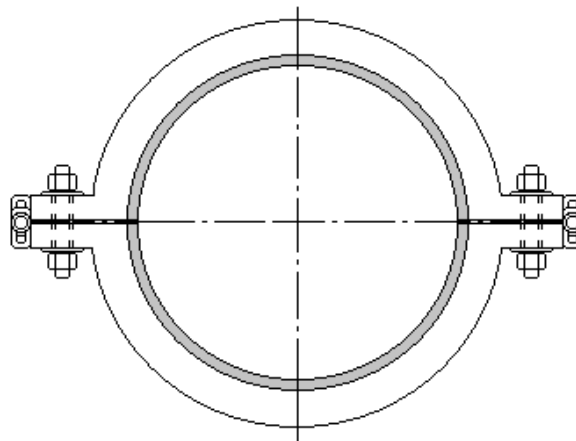

Figure 2. Metal crimp sleeve.

The crimp sleeve method is a reliable method, but it has some limitations. Firstly, these sleeves can be used only in the overhead pipeline. Secondary, tightening of threaded connections takes a lot of time. It increases oil spill impacts on the environment and the work crew. Thirdly, these sleeves do not provide hermiticity in case of combining a penetration defect of pipe wall with a “corrugation” type defect (item 4, RD 153-39.4-067-00) or if a longitudinal weld exists.

Along with the metal crimp sleeve method, “composite repair technology” is also used. The method consists in performing the following sequential actions: pipeline surface is cleaned with metal brushes, epoxy filler and primer are applied and the composite spiral sleeve is mounted by winding it onto the pipe body. Then, the sleeve filler sets hard (figure 3) and the defective pipeline section sealed.

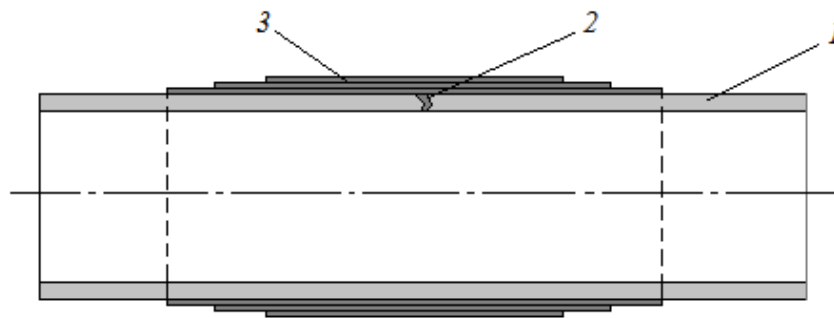

Figure 3. Composite sleeve: 1 – pipe body; 2 – local defect on the pipe body; 3 – repair structure consisted of the different number of turns of composite tape and glue

This method used for spills localization in the pipelines with low pressure - above 0.5 MPa and for hardening of defective sections of pipelines without oil spill. The using of this technology is greatly complicated in the case of oil spills, because spilling oil reducing patch adhesion and does not allow for complete sealing. In the oil industry composite technology of oil spill interruption can be used only in field and technological pipelines where it is possible to stop and emptied pipeline before repair.

Consider the option of oil spill interruption by emptying the defective section (figure 4). This method is based on the insertion of plungers into the defective section and into the section after the shut-off valves following the oil flow. The pumping is carried out on the bypass line, and the main line is being repaired. This method takes a lot of time and resources and used only when oil spills can't be interrupted with method discussed earlier.

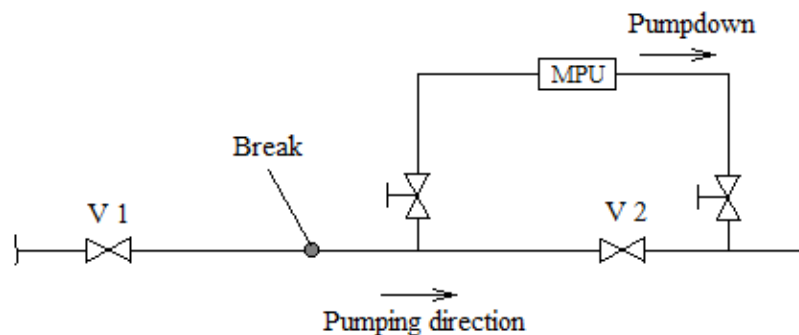

Figure 4. Defective section emptying scheme; V 1 и V 2 – line shut-off valves; MPU – mobile pumping unit.

This method also can be used only if all-season access to the pipeline is presented, otherwise off-road vehicles need to be used. It will increase the time and costs of operation.

Thus, it is impossible to stop the leak from a through defect in a short time for all the above technologies.

An alternative technology for preventing oil spill in case of an accident on a main oil pipeline is presented in this paper. The proposed technology is based on the Blaise Pascal law: “the pressure produced on a liquid or gas is transferred to any point without changes in all directions” [9].

B. Pascal's law is described by the formula:

$$P = \frac{F}{S} \quad (1)$$

where P – pressure, F – the applied force, S – the surface area.

The device is proposed to be manufactured in the form of a chamber for compressed air with a outside nipple for injecting compressed air out. According to the law of B. Pascal, the “clamping” force produced by compressed air will ensure a snug fit of the inner surface of the chamber to the pipeline and overlap of the through defect.

For simplicity, the camera is proposed to be made in a rectangular form, with a width B equal to the size of standard repair constructions, and a length L equal to the circumference of a defective pipeline. For a pipeline with an outer diameter of 325 mm, the length will be 1020 mm, and with a pipe diameter of 1220 mm - 3830 mm. Below is a diagram of the device (figure 5).

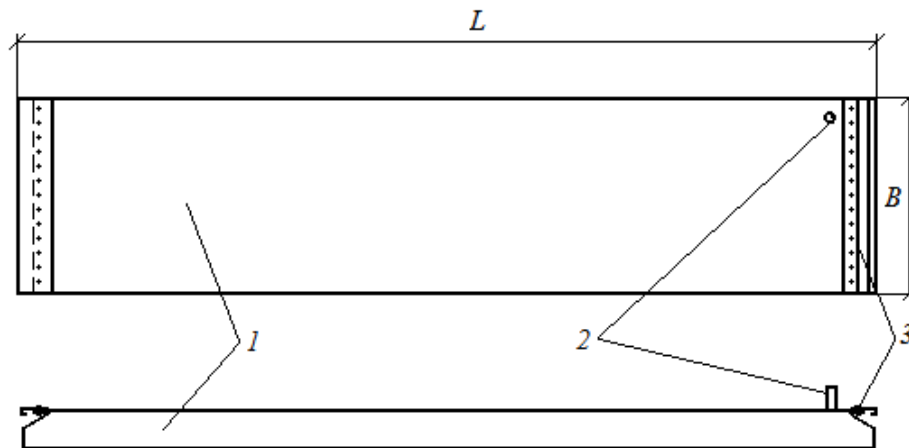

Figure 5. General view of the device for oil spill preventing in the event of an accident on the main oil pipeline: 1 – camera; 2 – nipple; 3 – lock.

The figure 6 shows a diagram of the lock with a bolt fastening to the pipeline.

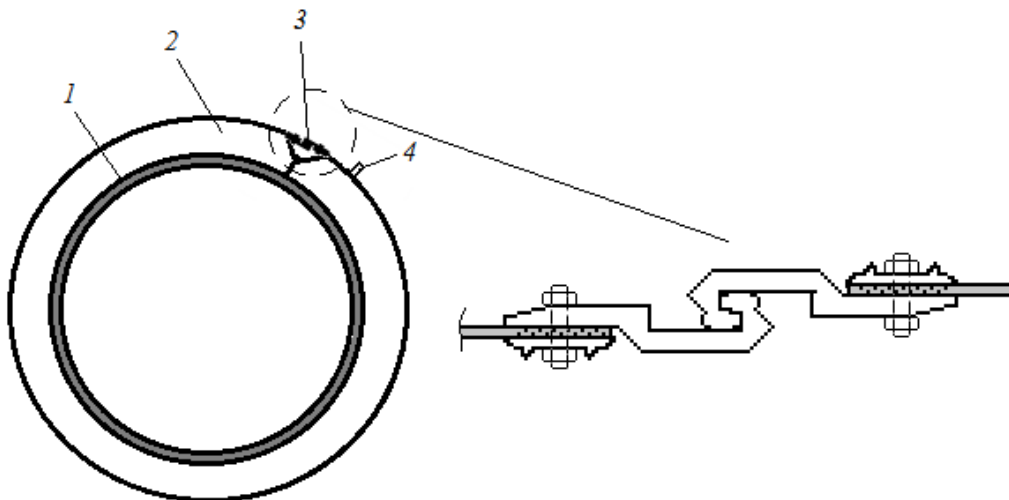

Figure 6. The scheme of the lock: 1 – the body of the pipe; 2 – the oil spill preventing device; 3 – the lock; 4 – the nipple.

The basis for oil spill booms can be used as a material for the camera. This is special wear-resistant polyester coated with petrochemical resistant polyvinyl chloride. Since the proposed material can stretch under load, it is necessary to use reinforcement of its surface. The high-strength woven geocomposite made up of modern geosynthetic components can be used for device reinforcing. A woven geocomposite is a web with longitudinal and transverse interwoven yarns. These yarns

instantly perceive the internal load. This web will increase the strength characteristics of the main material of the chamber and will provide minimal elongation of the chamber under loads.

The ASTM type lock is proposed to use for locking the device on the pipeline (figure 6). Usually this type of lock is used for booms. Spark proof lightweight and durable aluminum alloy with special heat treatment should be used as the material for the lock. This will give the alloy strength and corrosion resistance. The connection of the lock to the device is carried out through the clamping plate with a bolted connection. The clamping plate of the lock is equipped with spikes, which will allow you to securely lock the lock on the camera.

It is proposed to glue oil and petrol-resistant rubber with a high-strength epoxy adhesive on the inner surface of the chamber for ensure the tightness of the device.

An automobile chamber nipple vulcanized to the chamber can be used for pumping air into the chamber.

The proposed device allows to reduce the time to shut off the place of oil spill from the pipeline. This will reduce the amount of oil penetrating to the soil, which will reduce the destructive effect of the spill on nature. In addition, the time spent by the working team for localizing the breakthrough of the pipeline in the pit, will be reduced, and, consequently, the negative impact of hydrocarbons on the team members will be reduced.

References

- [1] Adegboye M, Fung W-K and Karnik A 2019 *Sensors* **19** (11) 2548
- [2] Li F, Dong H and Liang M 2018 *IOP Conf. Series: Materials Science and Engineering* **397** 012086
- [3] Zhang X, Yu R and Chen J 2020 *IOP Conf. Series: Materials Science and Engineering* **735** 012072
- [4] Ramírez-Camacho J, Carbone F, Pastor E, Bubbico R and Casal J 2017 *Safety Science* **97** 34-42
- [5] Prendergast D and Gschwend P 2014 *Journal of Cleaner Production* **78** 233-42
- [6] Bonvicini S, Antonioni G, Morra P and Cozzani V 2015 *Process Safety and Environmental Protection* **93** 31-49
- [7] Chatzigeorgiou D, Wu Y, Youcef-Toumi K and Ben-Mansour R 2013 *ASME 2013 Dynamic Systems and Control Conference* p 10
- [8] Michel J and Fingas M 2016 *World Scientific Series in Current Energy Issues Fossil Fuels* **1** (7) 159-201
- [9] Archimedes, Stevin S, Galileo G and Pascal B 1932 *The Beginning of Hydrostatics* (Moscow State Technical and Theoretical Publishing House) p 256