

Aviation to Grid: Airport Charging Infrastructure for Electric Aircraft

Zekun Guo¹, Xin Zhang^{1*}, Nazmiye Balta-Ozkan¹, Patrick Luk¹

¹ Centre for Energy Systems and Strategy, Power and Energy Theme, Cranfield University, Bedfordshire, United Kingdom

ABSTRACT

To decarbonise air transport sector, all-electric and hybrid-electric aircraft have advanced rapidly, particularly for small or regional electric aircraft (EA). However, the airport energy infrastructure for EA charging remains a key challenge owing to the high-power charging demand with highly-scheduled charging patterns. This paper develops an optimal airport charging infrastructure for EA. Battery swap and plug-in charging systems are proposed and compared in terms of charging schedule flexibility, costs and revenue. The novel mechanism “Aviation to Grid” is proposed to enable the bi-directional power flow interaction between power grid and EA charging system. The two alternative charging systems are implemented with different penetration levels of electric domestic flights in five case studies of London Gatwick airport. The optimal EA charging schedules with hourly generation dispatch and EA charging demand are developed. A conclusion is made that the battery swap is more economic when the EA penetration level is lower than 10%. The plug-in charge becomes a cost-effective option when the EA penetration level increases above 10%.

Keywords: Energy system planning, air transport, electric charging, battery swap, electric aircraft, grid operation

1. INTRODUCTION

Electric aircraft (EA) is a promising technology to combat global warming because of its potential to eliminate CO₂ emission, especially in the lower stratosphere [1]. Electrification as an ambitious technology which has demonstrated successful values in road transport such as electric vehicles [2], electrification is now pushed to address the sustainable aviation [3]. There is a key engineering challenge to design and build the future energy system infrastructure for airports with

EA battery recharging, in particular the EU Flightpath 2050 that requires aviation industry achieves a 75% reduction in CO₂ emissions and airports become emission-free by 2050. In EA design, it is important to consider the whole energy supply chain. For example, advanced EA concepts involving hydrogen will have a very different infrastructure from one that is battery-powered [4]. Driven by governmental environmental targets, it is envisaged that the electrification of transportation with the support of the grid will continue to evolve into a new energy ecosystem in the future [5].

Researchers have studied on the novel airport energy infrastructure design for EA charging system. The most common charging strategy is the battery swap. The optimized battery swap strategy for EA charging system could reduce peak-charging power to around 50% and the electricity costs by more than 20% [6]. The plug-in charge strategy requires high-power chargers to meet the flight schedules which are normally limited by charging hardware capacity, while the battery swap strategy needs a lot of spare batteries so that the battery investment costs are high [7]. Furthermore, the plug-in charge strategy is not applicable for EA with large battery capacity and high flight volume in regional airports due to the unrealistic high electric charging demand [8]. Furthermore the existing research has not considered the renewable energy integration to the EA charging system, or the bi-directional interaction between the EA charging system and the grid. In this paper, the novel concept of “Aviation to Grid (A2G)” is introduced to explore the possibility for EA charging system to not only consume electricity from the grid, but also supply the excessive electricity to the grid and generate revenue for the airport charging system.

This paper aims to develop an optimal EA charging infrastructure for the operations of a domestic electric aircraft fleet in the London Gatwick airport (LGW). In this

paper, the design and operation of both plug-in and battery swap charging strategies are optimized to minimize the investment and operating costs. Two charging systems are compared for five different penetration levels of EA fleet. A2G is designed to provide demand flexibility and generate revenue for airport charging system. Conclusion is drawn for airport energy system planners to determine different charging infrastructure based on the penetration levels of EA.

2. CHARGING INFRASTRUCTURE MODELLING

2.1 Airport-based solar PV system

Airport-based solar photovoltaic (PV) system becomes a promising technology to achieve low carbon emissions in aviation. The EA charging is partially supplied by an airport-based solar PV system. There are three main types of PV plants: ground-mounted on airport land, canopy-supported in airport carparks, and rooftop-mounted on airport buildings [9]. The power output of the PV plants can be calculated by (1).

$$P_{PV,t} = P^{STC} \frac{r_t}{r^{STC}} [1 + k_T (T_t - T_r)] \quad (1)$$

Where, $P_{PV,t}$ is the output power of PV plant at time t . P^{STC} is the maximum output power of the PV cell under the standard test condition (1000 W/m², 25°C). r_t is the light intensity of the k th PV cell at time t . r^{STC} is the standard test light intensity of the k th PV cell, equals 1000 W/m². k_T is the power temperature coefficient. T_r is the reference temperature, 25°C in this study. T_t is the temperature of the PV cell.

The power generated by PV can be charged to EA, sold to the grid, or stored in energy storage system (ESS). The electrical balance can be described by:

$$P_t^{PV} = \sum_{dev} P_t^{PV,dev} \quad (2)$$

Where, dev denotes the energy devices, including ESS, grid, and EA batteries.

2.2 Plug-in charging system

The arrival flights will stay in a defined time of 30 to 50 minutes for ground operation. As a result, the plug-in charging system requires high-power and super-fast chargers in such limited turnaround time. Fig 1 shows the proposed energy infrastructure for plug-in charging in airports.

The power provided by the grid, PV and ESS are supplied to meet the charging demand of EA.

$$P_t^{grid,EA} + P_t^{PV,EA} + P_t^{ES,EA} = P_t^{EA} \quad (3)$$

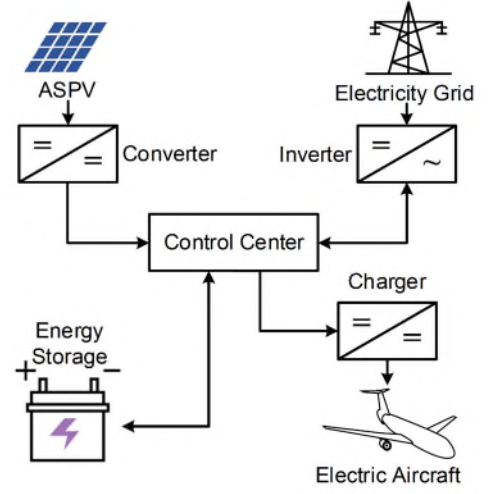

Fig 1 Plug-in charging infrastructure system

The energy stored in ESS can be formulated by

$$E_t^{ES} = E_{t-1}^{ES} + \eta_c P_{c,t}^{ES} - \eta_d P_{d,t}^{ES} \quad (4)$$

$$P_{c,t}^{ES} = (P_t^{PV,ES} + P_t^{grid,ES}) \quad (5)$$

$$P_{d,t}^{ES} = (P_t^{ES,EA} + P_t^{ES,grid}) \quad (6)$$

2.3 Battery swap charging system

Battery swap charging system is shown in Fig 2. Battery swap process can be formulated by a state flow scheduling model. There is no need to add separate ESS for battery swap strategy because the idling batteries in the swap station can work as ESS. For safety consideration, battery swap process (together with the ordinary cargo loading process) is estimated to take place in 10 minutes after the EA approaching at the apron with all the passengers have de-boarded [10].

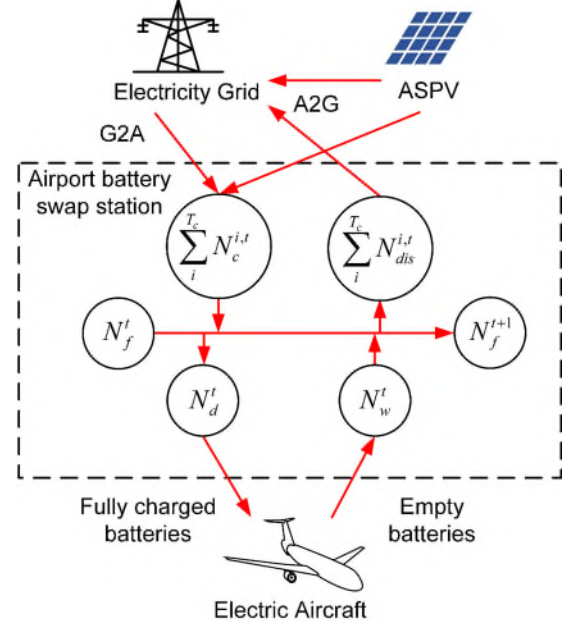

Fig 2 Battery swap charging infrastructure system

The battery swapping process assumes the total number of batteries is fixed in airport battery swap station. Four battery charging states are defined as charging, discharging, fully charged and empty. Batteries are scheduled to transit between these states by state flow scheduling model from the previous time $t-1$ to the current time t . The discharging state enables the ESS function by using spare batteries at airport battery swap station. The charging status i represents the state of charge (SoC) of batteries. In charging or discharging states, the i increases or decreases by 10% from $t-1$ to t .

The number of batteries in each state is calculated based on the state flow scheduling model and EA flight schedules. The following equation shows the number of batteries in each state that

$$\sum_i^{T_c} (N_c^{i,t} + N_{dis}^{i,t} + N_w^{i,t}) + N_f^t = N_b \quad (7)$$

Where $N_c^{i,t}$ is the number of batteries in charging state with SoC i at time t . $N_w^{i,t}$ represents the empty batteries. N_f^t represents the fully charged batteries. N_b is the total number of batteries at an airport battery station.

The following equation represents the battery swapping process:

$$N_{dc}^{i,t} + N_{dw}^{i,t} = N_d^{i,t} \quad (8)$$

Where $N_{dc}^{i,t}$ represents the number of empty EA batteries which start charging with SoC i at time t . $N_{dw}^{i,t}$ is the number of empty EA batteries that are queueing for charging. $N_d^{i,t}$ is the number of batteries that are swapped from EA at time t .

The following constraint is proposed to ensure the charging batteries should not exceed the total number of chargers:

$$\sum_i^{T_c} (N_c^{i,t} + N_{dis}^{i,t}) \leq N_{ch} \quad (9)$$

Where $N_c^{i,t}$ is the number of charging batteries with SoC i at time t .

2.4 Aviation to Grid

The novel concept Aviation to Grid (A2G) is proposed to simulate a bi-directional interaction between the EA charging system and the power grid. The energy sources from airport to grid include PV, ESS, and the EA batteries. The electricity will be sold back to the grid when

exceeding the airport demand. Plug-in and battery swap charging systems will both apply the A2G strategy. The A2G power balance can be expressed:

$$P_t^{grid} = P_t^{G2A} - P_t^{A2G} \quad (10)$$

$$P_t^{G2A} = P_t^{grid,EA} + P_t^{grid,ES} \quad (11)$$

$$P_t^{A2G} = P_t^{ES,grid} + P_t^{PV,grid} \quad (12)$$

3. OPTIMAL SIZING OF CHARGING INFRASTRUCTURE

Both proposed models for plug-in and battery swap charging systems are considered as mixed integer linear programming (MILP) problems, and solved by CPLEX solver under MATLAB. The objective of infrastructure optimization is to minimize the total CAPEX and OPEX costs as formulated in (30).

$$Obj = \min \left(CAPEX + \sum_s (OPEX - R_{A2G} + C_{emis}) \right) \quad (13)$$

The capital expenditure (CAPEX) is the sum of all capital costs of charge system devices. Moreover, the annual CAPEX is calculated by multiplying the capital recovery factor (CRF), r is the interest rate considered to be 6%, the system life cycle y is 20 years.

$$CAPEX = \sum_{dev} Cap_{dev} \times C_{dev}^{Cap} \times CRF \quad (14)$$

$$CRF = \frac{r \times (1+r)^y}{(1+r)^y - 1} \quad (15)$$

The annual operation cost (OPEX) equals to the grid electricity purchase costs in summer and winter seasons based on the typical days of EA demand.

$$OPEX = \sum_{t=1}^T (P_{grid,t} \cdot p_e \cdot \Delta t) \quad (16)$$

The equivalent CO₂ emission cost for grid electricity is calculated by applying the emission factor of 0.55 tCO₂/MWh.

$$C_{emis} = \sum_{t=1}^T \varepsilon \cdot P_{grid,t} \cdot \beta_e \cdot \Delta t \quad (17)$$

Where ε is the CO₂ emission allowance, β_e is the emission factor.

The revenue of A2G is calculated by:

$$R_{A2G} = \sum_{t=1}^T (P_{A2G,t} \cdot p_{A2G} \cdot \Delta t) \quad (18)$$

Where p_{A2G} is the Feed-in tariff of sold electricity to the grid.

4. RESULTS AND DISCUSSION

4.1 Case study

The case study is based on the London Gatwick Airport. A certain percentage of the existing flight is assumed to be replaced by EA, which is defined as EA penetration rate.

The “Eviation Alice” is considered as a reference EA, the technical characteristics of which are summarized in [11], including a 900 kWh onboard battery. The 1,046 km distance range of this aircraft is suitable for domestic commuting flight in the UK. The SoC of each arrival aircraft is considered to be 30% for energy reserve to cover emergency flight missions.

The flight schedules of 5th June and 12th Nov 2019 are used as typical days in this study, as shown in Fig 3 [12]. The turnaround time of the flights is 50 minutes. The battery swap or plug-in charging process will occur after 10 minutes of flight arrival [10]. 5 case studies are conducted with the EA penetration levels of 5%, 10%, 15%, 20%, and 25%.

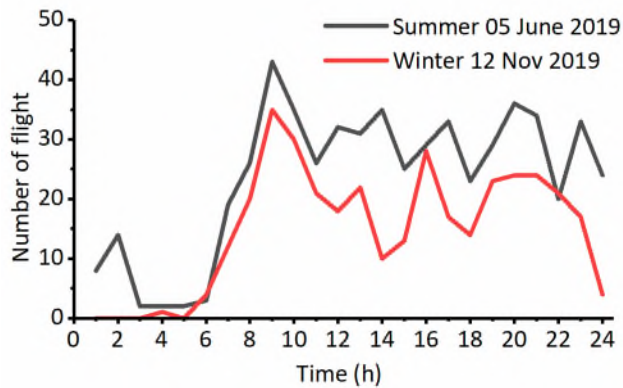

Fig 3 Flight schedules of London Gatwick Airport

4.2 Infrastructure planning

The input parameters for the airport charging infrastructure are shown in Table 2. The sizing of energy devices including PV, ES, Grid for both plug-in and battery swap charging system are summarized in table 3. In general, the capacity of energy devices will expand following by the increased EA penetration rate. The size expansion of airport charging infrastructure will allow higher electricity supply for larger EA charging demand.

Significant high-power chargers are required for plug-in charging due to the high charging demand in short flight turnaround time. Due to the longer charging time required by battery swap strategy, more chargers are planned in battery swap charging system. The grid transformer capacity is higher for battery swap because of the higher A2G demand. The PV installation capacity reaches the maximum in each case, because the levelized generation cost of PV is cheaper than grid.

Table 2 Parameters of airport charging infrastructure system

Parameter		Value	Units
Installation cost	PV*	1,500	£/kWp
	Transformer	25,000	£/MVA
	Battery	150,000	£/each
	Charger for battery swap	10,000	£/each
	Charger for plug-in charge	100,000	£/each
	Energy storage	150,000	£/MWh
Life time	ESS	100,000	£/MW
	The whole system	20	Year
Electricity price	0:00-7:00, 21:00-24:00	0.1	£/kWh
	7:00-21:00	0.2	£/kWh
Feed-in tariff	0:00-7:00, 21:00-24:00	0.05	£/kWh
	7:00-21:00	0.08	£/kWh
Emission cost	CO ₂	20	£/t

*PV CAPEX data is from [13]

4.3 Generation schedule with charging demand

The optimal generation schedules to meet EA charging demand for both plug-in and battery swap charging scenarios are shown in Fig 4. The plug-in charging demand follows the flight schedules with a “double peak” characteristic, while the battery swap charging scenario manages to spread out the EA charging demand more evenly. During the day, the battery swap scenario reduces the demand peak by 2.93 MW, while during the night the battery swap scenario increases the demand trough by 2.62 MW. Furthermore, plug-in charging scenario requires large ESS of 16 - 33 MWh to smooth out the EA charging demand due to the variations in flight schedules. The spare batteries in battery swap station also play an effective role in smoothing out the charging demand profile.

The mismatches between PV generation and charging demand occurs in both plug-in and battery

Table 3 Infrastructure sizing

Infrastructure	Unit	Plug-in charge					Battery swap				
		5%	10%	15%	20%	25%	5%	10%	15%	20%	25%
PV	MW	23	23	23	23	23	23	23	23	23	23
Transformer	MVA	8	8	9	10	12	10	11	10	11	11
Charger number	Quantity	3	4	6	6	8	11	12	13	14	18
Charger capacity	MW	1.26	1.26	1.26	1.26	1.26	0.3	0.3	0.3	0.3	0.3
Battery	Quantity	-	-	-	-	-	11	12	13	14	18
ESS	MWh	16	17	20	26	33	-	-	-	-	-

swap charging scenarios. Therefore, the excessive PV generation will be sold to the grid as A2G. In plug-in charging scenario, most of PV generation will be absorbed by EA batteries due to the high-power charging, part of the exceed PV generation is stored in the ESS. In battery swap scenario, higher volume of PV generation is sold back to the grid, which making this scenario a higher A2G power output.

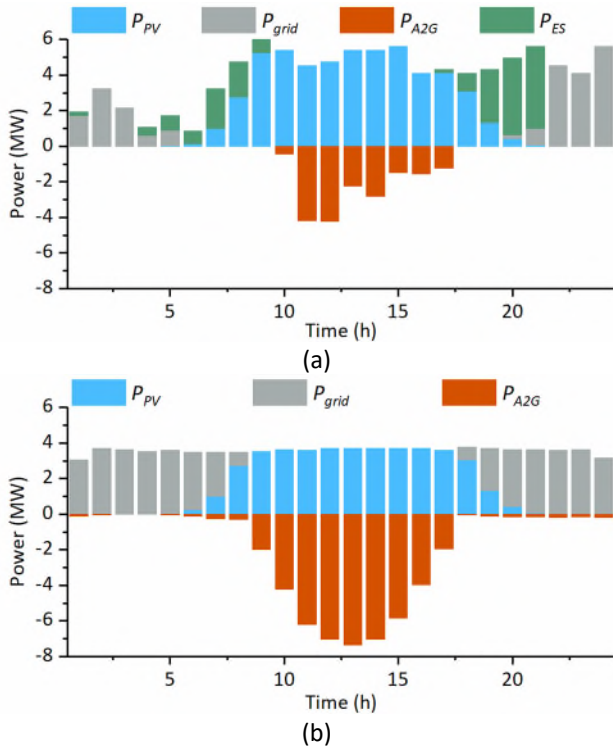

Fig 4 Generation schedules with charging demand for case study 3. (a) plug-in charge, (b) battery swap.

4.4 Costs and revenue

Fig 5 illustrates the cost and revenue of plug-in and battery swap charging systems for each case study. The CAPEX costs are higher for plug-in charging system because the higher investments on the high-power chargers and ESS. At the same time, the higher PV self-consumption rate makes a lower OPEX for plug-in charging system. In the first two cases with EA penetration rate 5% - 10%, the battery swap charging system becomes a better choice due to the lower overall costs that is off-set by higher A2G revenue. However, with the increasing number of EA penetration rate above 10%, the plug-in charging system becomes an economic charging solution due to the higher battery investment costs for battery swap.

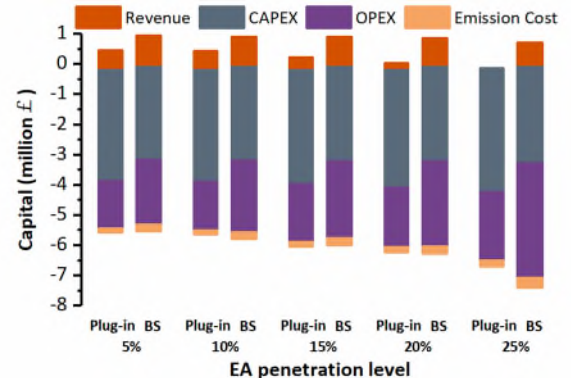

Fig 5 Cost and revenue of different charging systems

5. CONCLUSIONS AND FUTURE WORK

This paper addresses the challenge for future airports to develop charging infrastructure for electric aircraft (EA). Plug-in and battery swap are proposed as two EA charging infrastructure systems. The optimisation objective of charging system to minimize the CAPEX, OPEX, and emission costs. The novel concept of A2G is introduced in both charging systems to increase the EA charging revenue and provide flexibility to the grid. The plug-in and battery swap charging systems are implemented for domestic flights in LGW airport with different EA penetration levels.

The optimal EA charging schedules with hourly generation dispatch are developed for battery swap and plug-in charge scenarios. The charging demand profile of battery swap system is smoother than the plug-in charging demand, due to the swappable batteries that can offer flexibility to reduce the variations of EA charging demand. Battery swap scenario not only shaves the peak demand, but also provides more flexibility in terms of A2G services.

The economic analysis on cost and revenue of two charging systems indicate that the battery swap charging system is more economic when the EA penetration level is lower than 10%. The plug-in charging system becomes a cost-effective option when the EA penetration level increases above 10%.

Future research will introduce the uncertainties for the airport energy system planning. The planning and operation of EA charging infrastructure for multiple UK airports will be developed to quantify the techno-economic impacts of aviation electrification. The interaction between the EA charging system and wider energy networks will also be studied.

ACKNOWLEDGEMENT

This work is sponsored by EPSRC Supergen Energy Networks Hub Flexible Fund: 'GREEN Airport - Grid

flexibility by Electrifying Energy Networks for Airport (SENF1-023)', and Department for Transport Transport-Technology Research Innovation Grant (T-TRIG): 'Aircraft to Grid: Hybrid and Smart Charging for Electric Aircraft', in the United Kingdom.

REFERENCE

- [1] Schäfer AW, Barrett SRH, Doyme K, Dray LM, Gnadl AR, Self R, et al. Technological, economic and environmental prospects of all-electric aircraft. *Nat Energy* 2019;4:160–6. <https://doi.org/10.1038/s41560-018-0294-x>.
- [2] Das HS, Rahman MM, Li S, Tan CW. Electric vehicles standards, charging infrastructure, and impact on grid integration: A technological review. *Renew Sustain Energy Rev* 2019. <https://doi.org/10.1016/j.rser.2019.109618>.
- [3] Aerospace Technology Institute. Accelerating ambition Technology Strategy 2019. 2019.
- [4] Luk PCK. Superconducting machines - The enabling technology for future electric propulsion in aircraft. 2017 7th Int. Conf. Power Electron. Syst. Appl. - Smart Mobility, Power Transf. Secur. PESA 2017, 2018. <https://doi.org/10.1109/PESA.2017.8277766>.
- [5] Luk PCK. Towards a new energy eco-system: The convergence of the electric grid and the electric vehicle. *IET Conf. Publ.*, 2018. <https://doi.org/10.1049/cp.2018.1740>.
- [6] Justin CY, Payan AP, Briceno SI, German BJ, Mavris DN. Power optimized battery swap and recharge strategies for electric aircraft operations. *Transp Res Part C Emerg Technol* 2020;115:102605. <https://doi.org/10.1016/j.trc.2020.02.027>.
- [7] Francesco Salucci, Carlo E. D. Riboldi, Lorenzo Trainelli AR. Optimal Recharging Infrastructure Sizing and Operations for a Regional Airport. *Aerosp. Eur. Conf.*, 2020.
- [8] Salucci F, Trainelli L, Faranda R, Longo M. An optimization model for airport infrastructures in support to electric aircraft. 2019 IEEE Milan PowerTech, *PowerTech* 2019, 2019. <https://doi.org/10.1109/PTC.2019.8810713>.
- [9] Sukumaran S, Sudhakar K. Fully solar powered airport: A case study of Cochin International airport. *J Air Transp Manag* 2017;62:176–88. <https://doi.org/10.1016/j.jairtraman.2017.04.004>.
- [10] Schmidt M, Paul A, Cole M, Ploetner KO. Challenges for ground operations arising from aircraft concepts using alternative energy. *J Air Transp Manag* 2016. <https://doi.org/10.1016/j.jairtraman.2016.04.023>.
- [11] Alice | Eviation n.d. <https://www.eviation.co/alice/> (accessed September 21, 2020).
- [12] FlightStats - Global Flight Status & Tracker, Airport Weather and Delays n.d. <https://www.flightstats.com/v2/> (accessed June 27,

- [13] 2020). Solar photovoltaic (PV) cost data - GOV.UK n.d. <https://www.gov.uk/government/statistics/solar-pv-cost-data> (accessed November 25, 2020).