

Tuneable Microwave Photonics Filter based on Stimulated Brillouin Scattering with Enhanced Gain and Bandwidth Control

Mian Ali, Shyqyri Haxha*, *Senior Member IEEE* and Ian Flint

Abstract—A Tuneable Microwave Photonics Gain Filter (TMWPF) is proposed based on Stimulated Brillouin Scattering (SBS). The TMWPF configuration exhibits a gain of $\approx 70\text{dBm}$ and tuneable bandwidth control which makes it attractive for applications requiring high gain and bandwidth variations with high precision. The proposed TMWPF configuration employs a tuneable laser, an Erbium-Doped Fibre Amplifiers (EDFA), Radio Frequency (RF) mixers, an RF Amplifier (RFA), Single Mode Fibre (SMF) and Gallium Arsenide (GaAs) I-Q Dual parallel Mach-Zehnder Modulator (DPMZM). The modulation scheme performed by I-Q DPMZM is controlled by a voltage bias controller. The performance of the filter is compared whilst using LiNbO₃ Phase Modulators (PMs) and Intensity Modulators (IMs) instead of GaAs I-Q DPMZM. The TMWPF delivers 44dBm, 57dBm & 44dBm of gain for I-Q DPMZM, PM, and IM, respectively. The use of RFA resulted in a total gain of 62dBm, 69dBm & 52dBm for I-Q DPMZM, PM and Amplitude Modulators (AM), respectively. This configuration exhibits high Q, tuneable bandwidth by employing stokes SBS gain, RF mixer and RFA. The bandwidth of the filter is varied from 20MHz to 40MHz. The operation principle of the TMWPF is based on SBS stokes gain. By controlling the bias point of the I-Q DPMZM, the operating point can be varied between PM and IM allowing 6dBm gain control and the choice of PM or IM for specific applications. This gives improved filter performance. The full control of TMWPF's gain is obtained by using EDFA. The EDFA controls the power of the tuneable laser pump. The control challenges of the proposed TMWPF along with improvement enhancements are reported. The proposed TMWPF exhibits tuneability of 32GHz in RF domain, and 40GHz in optical domain. To the best of our knowledge, this TMWPF exhibits the highest reported gain.

Index Terms—Microwave photonics, Tuneable Microwave Photonics Filter, Stimulated Brillouin Scattering, Optical Gain Filter, Narrow bandwidth selective gain, Phase modulation, Amplitude modulation and I-Q Modulation.

I. INTRODUCTION

The use of photonics to transport and manipulate RF signals in advanced communication systems is very attractive for many reasons. Photonics allows transmission of RF signals with very low loss and low dispersion over the size of the platform. Photonics offers much higher Q in RF domain than electronic RF circuits. The Quality (Q) factor of a filter is reciprocal of -3dB bandwidth to centre frequency. A high Q factor will produce a narrow passband filter. A filter with a Q factor of greater than 200 is considered a narrow bandwidth filter. The higher effective RF Q of photonic filters allows superior RF signal processing over the electrical domain. Furthermore,

improvements in signal integrity and tuneability are possible through signal processing [1]. Microwave Photonic Filters (MPF) filters will play a major role in advanced communication systems, such as aerospace, defence, and 6G and beyond.

There are various commercial photonic filters. However, they all have limitations [2]. For example, high effective Q in the RF domain requires an actual 10,000 times higher Q in the optical domain. Unsurprisingly the physics behind such massive Q is environmentally sensitive. For example, to temperature and vibration. SBS has the merit that it dynamically “locks on” the optical pump frequency. This makes SBS filtering largely independent of vibration and temperature and yet tuneable. An example of a tuneable single bandpass MPF has been demonstrated in [3] using Fabry-Perot semiconductor optical amplifier by changing the phases of PM sidebands with a tuneability of 40GHz and a bandwidth from 99MHz to 18.3GHz. However, the reported [3] filter exhibits a low Q and wide pass band and has extreme environmental sensitivity unless significant precautions are taken around the Fabry-Perot. MPFs based SBS have additional advantages over the above photonic filters since they can exhibit high gain, and narrow bandwidth of 10's MHz [4-7], MPFs based on SBS using Single-Sideband (SSB) or Double Sideband (DSB) with suppressed carrier modulation have shown drift bias problems [4-7]. However, note these do not affect the RF frequency or line width. Other examples: MPF based on SBS with a gain of 20dBm is reported in [8]; where the bandwidth of reconfigurable passband filter is realized using a single fixed laser; A 5-line optical comb pump and three Mach Zehnder Modulators (MZMs) are used. A similar MPF based on SBS for extraction application of sub-band Orthogonal Frequency Division Multiplexing (OFDM) is presented in [9], using a single laser. In ref. [10] an MPF based on SBS is reported for a dual band with a fixed frequency interval of 2.434GHz which has passbands of 20dBm. Integrated silicon chip based SBS tuneable filter of 10GHz range with a passband of 1.93GHz is reported in [11]. The reported MPFs based on SBS design [4-11] show a large tuneable range narrow bandwidth. However, they use a single fixed laser that limits the operating range due to the use of MZM to generate the pump light. Using a single fixed laser, tuneable range of MPF is limited by the bandwidth of modulator which is used for generating pump. Although, single laser offers improved phase noise figure, but due to the recent advanced technology such as highly wavelength stable lasers and frequency locking techniques, the use of tuneable laser with fixed laser can help achieve much wider tuneability.

An MPF based on SBS which deploys tuneable laser to generate SBS pump superimposed by an RF signal for a phase-modulated signal is reported in [12]. Yet, their results are shown for phase modulation with a tuning range of up to only 20GHz with a maximum gain limited of 35dBm. By using tuneable laser without Mach Zehnder Intensity Modulator (MZIM), the drifting bias challenges faced in SBS filters (fixed single laser) is eliminated and a wider tuning range is achieved.

The I-Q DPMZM is designed for advanced modulation schemes such as Quadrature Amplitude Modulation (QAM). To the best of our knowledge, this is the TMWPF with highest gain system performance deploying GaAs I-Q DPMZMs which has most significant capabilities in managing RF signals and exhibits excessive performance in harsh operating environment in terms of thermal stability, power-handling, radiation resistance and longevity for aerospace, defence, and satellite-to-ground downlink communication system applications, including advanced modulation schemes such as broadband digital communication required by modern communication systems. Similarly, SBS-based MPFs can offer major advantages such as the removing of electronics from the antenna in ~~for~~ ultra-high-speed communications systems such as 5G and 6G, including 4D videos. Such systems require high data rates and beam steering techniques [13]. Also, optical sub systems required for such systems all-optical signal processing i.e., suppression of harmonics and intermodulation distortion products [14-15], up-conversion and/or down-conversion [16].

Presented here is the design and demonstration of a TMWPF based on SBS using tuneable laser, RF Amplifier (RFA), a Gallium Arsenide (GaAs) I-Q DPMZM modulator (axenic aXMD2150) along with fixed wavelength laser (Gooch & Housego EM4). This paper proposes a novel microwave photonic system configuration of Radio Frequency Amplifier (RFA) after Stimulated Brillouin Scattering (SBS) gain. It demonstrates that a uniquely high gain amplification is achievable by employing RFA after SBS amplification. The traditional amplification employs an EDFA to control the pump power and consequently Brillouin gain saturation occurs. Gain saturation is where increasing pump power does not increase the RF signal gain (the probe signal). Thus, if the SBS is increased beyond saturation the gain of the RF signal of interest, instead it will increase of noise floor. To get around this problem this paper presents a unique approach of RF mixing of pump with square wave to increase the bandwidth of SBS. This approach increases the SBS gain from 20MHz to 40MHz by changing the frequency of square wave from 1MHz to 5MHz. The RF Mixing produces multiple pumps with equidistance of 1MHz to 5MHz. This technique is simpler to implement, and the laser tuneable pump remains completely in phase and the power distribution is gradually decreased from the centre of the pump resulting in good response of the filter rather than using two separate pumps or combs.

To demonstrate this photonics configuration, a GaAs I-Q DPMZM as modulator of interest is used and results are compared with traditional Lithium Niobate (LiNbO₃) Intensity Modulator (IM) (Thorlabs LN05S) and Phase Modulator (PM) (Thorlabs LN27S). The bias point of GaAs I-Q DPMZM allows

7dBm gain control. The bias control I-Q DPMZM can also be varied anywhere in the I-Q plane, from IM to PM by adjusting the voltage biasing point where advantages and disadvantages in terms of gain and noise are also discussed. The voltage biasing control shifts GaAs I-Q MPMZM between IM and PM where it is shown that the PM signals achieve higher gain than IM. The traditional control of TMWPF is performed by EDFA (Thorlabs EDFA100S) since it directly enables SBS gain in the SMF. The GaAs-based modulators are comparatively more temperature independent and resilient to the bias drifting, than LiNbO₃ modulators. I-Q DPMZM are becoming modulators of choice for ultra-high-speed aerospace and defence applications. The proposed TMWPF implemented in this paper is a positive gain filter. The TMWPF achieved gains of 64dBm, 70dBm & 52dBm for I-Q DPMZM, PM, and IM, respectively. The proposed TMWPF system configuration deploys the RFA for post-SBS amplification for the stated gains. To achieve high amplification, it is crucial to deploy RFA after the SBS gain. Without the RFA the following gain is achieved; 47dBm, 57dBm & 33dBm for GaAs I-Q DPMZM, LiNbO₃ PM, and LiNbO₃ IM, respectively.

The TMWPF experimental setup, operating principle, and system optimisation are given here. The proposed TMWPF can be deployed for advanced communication systems such as 5G, 6G, aerospace and satellite applications. The key advantages of the proposed TMWPF's are widely tuneable range, tuneable bandwidth, high gain, and gain control via bias control for I-Q DPMZM.

II. SETUP & OPERATING PRINCIPLE

The operating principle of TMWPF is based on SBS-gain of Single Mode Fibre (SMF). SBS gain allows phase and synchronisation to the original signals. This phenomenon can result in additional gain on Phase Modulation to Amplitude Modulation conversion (PM to AM) [17]. During PM to AM, more signal is detected using direct photodetector. A fixed laser was used to modulate the RF with I-Q DPMZM, which is then filtered/amplified with SBS from a tuneable laser pump. By using this technique, a tuneable stable TMWPF with a high Q is realized. The bias control of the I-Q DPMZM can be used to achieve either PM or IM. The I-Q DPMZM results are compared with LiNbO₃-based IM and PM by swapping I-Q DPMZM with MZIM and PM, respectively. The I-Q DPMZM is biased and used as a phase modulator to generate 0 & π phase-modulated output [18]. The use of I-Q DPMZM as PM or IM offered 7dBm gain control. Controlling SBS of TMWPFs typically carried out by EDFA. The EDFA increases or decreases pump capacity, which causes Brillouin scattering. One disadvantage of such control is that by adjusting SBS gain results in varying phase delay, nevertheless this control allows full gain control.

To select and amplify the RF signal from the modulator in the optical domain, a tuneable laser-based pump is deployed. The tuneable laser is a TLX1 [19] C-band tuneable laser with a dither option. The dither signal is used to improve wavelength accuracy which is processed electronically to form feedback-based control system. It also results in phase and frequency

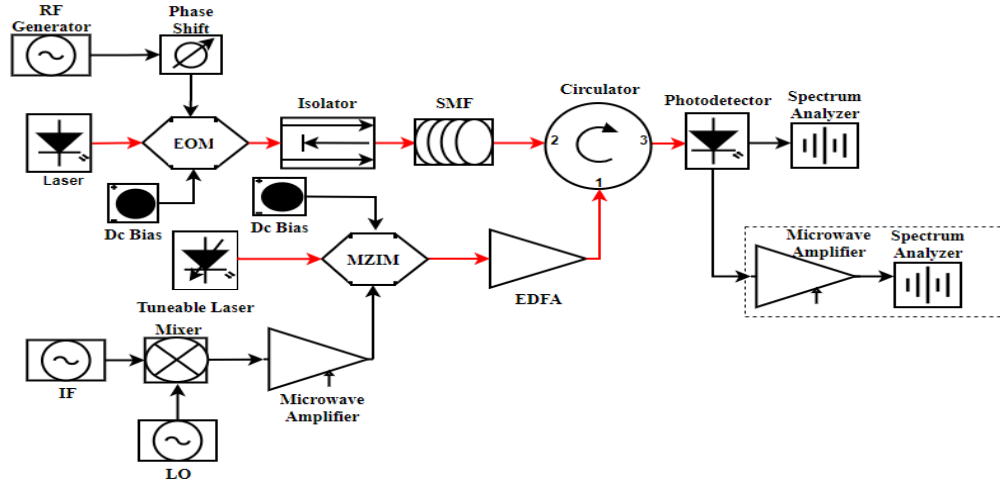

Figure 1 Tuneable Microwave Photonics Filter (TMWPF) based on Stimulated Brillouin Scattering (SBS)

noise; therefore, it has negative impact on filter amplification. So, it is recommended to leave the dither option off. A better solution is to use a tuneable laser with a high wavelength accuracy. Another option is also to use frequency locking with both tuneable and fixed lasers [20]. The use of frequency locking between lasers uses PID control with actuator to tune and keep wavelength difference between both lasers fixed. The second option is using available tuneable lasers with less than 37 MHz wavelength accuracy. Use of such lasers is best for long-term filter accuracy along with highly stable fixed laser, such as Thorlabs Frequency stabilized to NIST-Traceable Transition of C2H2 which offers a stability of less than 25MHz. If the RF signal is phase modulated by π , then no RF is produced at the photodiode unless it is amplified by SBS TMWPF. The Modulated RF signal's sideband coincides with the SBS signal from the pump. This produces RF amplification, as described by the equations [12].

$$f_C + f_M = f_P - f_B \quad (1)$$

Whereas f_C , f_M , f_P , and f_B are the fixed laser frequency, RF signal frequency, tuneable laser pump frequency and Brillouin shift, respectively. By substituting a Brillouin shift of 10.816GHz for the SMF used in experimental setup and a fixed laser carrier frequency of 193.404THz in Eq. (1), hence the following relationship between the pump and the RF signal:

$$\begin{aligned} f_P &= f_C + f_B + f_M \\ f_P &= 193.414816THz + f_M \end{aligned}$$

This result is used for tuning the pump to RF with the addition of 193.414816THz. The centre frequency of the TMWPF is the frequency of the tuneable laser pump minus the Brillouin shift and the fixed carrier frequency, as shown in the following equation [12]:

$$f_{MWP} = f_P - f_B - f_C \quad (2)$$

The centre frequency of the TMWPF can be varied by tuning the pump frequency. This allows different signals in the optical channel to be selected and amplified. The SBS-based filter's transfer function response is expressed as [21]:

$$H(f) \propto G(f) \exp[j\varphi(f)] - 1 \quad (3)$$

Where G and φ represent the gain and phase difference of the filter. The transfer function shows the filter gain which is directly proportional to SBS gain in the medium, and the phase shift of RF signal applied confirms that PM signals are amplified more than IM signals. The gain of the SBS follows the Lorentzian function [22] which is determined by the length of the optical fibre L , pump power P_p , and Brillouin gain of the medium g_o [21].

$$G = \exp \left\{ \frac{\eta_{SBS} g_o P_p L}{2} \frac{(\frac{\Delta V_B}{2})^2}{(f_C - f_P - V_B - f)^2 + (\frac{\Delta V_B}{2})^2} \right\} \quad (4)$$

Where n_{SBS} and V_B are effective refractive index and Brillouin shift, respectively. In contrast, the Full Width Half Limit (FWHM) of the SBS has standard values, ranging from 20MHz to 25MHz. The gain changes with polarisation are maximum when the probe polarisation is aligned with that of the pump [23], therefore all the equipment used in this experiment are polarization maintaining such as Tuneable laser, Circulator, Isolator, EDFA and Optical fibre patch. It is challenging to maintain the polarisation in the SMF. However, the polarisation is maintained for both the pump and the modulated signal at the optical fibre inputs which lead to obtain maximum gain. The polarisation is verified by using a polarimeter (Thorlabs PAX1000IR2). As an optical medium, a 10KM Single-Mode Fibre (SMF-28) is used. The Brillouin threshold for fibre focused beam was measured to be 11dBm. Specialist fibres with high Brillouin gain can also be used which will decrease the length of the fibre required for the filter. Chalcogenide fibres are an attractive option due to large Brillouin coefficient, nevertheless they are essentially available as multimode fibres which means it is difficult to use them as Single mode which is highly beneficial for Brillouin gain. In this novel microwave photonics tuneable filter configuration, the RF Mixer is RF MARKI mixer M10418NA, RF spectrum Analyzer Advantest U3771, and the following RF signal generators; HP 83596B, HP83592A and Tektronix AFG1022.

The dc bias point is controlled via three power supplies, as I-Q DPMZM has three electrodes P, Q, and I for bias control of parent, child 1 and child 2 bias points, respectively. For signals up to 40GHz, connectors of 2.92mm are used. The proposed TMWPF structure configuration is illustrated Fig. 1. The RFA is deployed after SBS amplification where an additional of approximately 20dBm gain is generated. To achieve highest gain, the RFA should be deployed after SBS amplification. The modulator uses the fixed laser beam to generate modulation of the RF signal input from the RF source. The RF has been varied up to 40GHz. In case, where the I-Q modulator is used as a PM, the phase shifter after the RF source is deployed to generate phase difference, however phase shifter is not used for PM or IM. The modulator's output is routed through an isolator, which only allows light to propagate from the modulator to the SMF while blocking light from the SMF to the modulator. Modulator's output enters the SMF via the isolator, then it enters the circulator from point 2 and travels towards point 3. The bandwidth control is achieved through the MZIM along with tuneable laser with RF input from mixer. The mixer output is amplified by the RFA. The modulated optical output is amplified by the EDFA. If tuneable bandwidth feature is not required, then RF mixing along with MZIM can be eluded and the tuneable laser can be directly used as pump, governed by Eq. 2. The TMWPF response is governed by using Eq. 2. The TLX1 laser has an optical attenuator built in to match the maximum input levels of EDFA. The EDFA amplifies the laser to generate the SBS. The output light from the EDFA enters the circulator from point 1 and it enters SMF while leaving from point 2 and travels in the opposite direction as a signal from the modulator in the SMF. The SBS is generated at the SMF. The SBS is generated in the opposite direction of the light at the pump and with a down frequency shift equal to the Brillouin shift. Once the Brillouin shift matches the RF signal sideband in the optical domain, then the RF signal is amplified. After amplification, the RF signal exits the circulator at point 3. At the photodetector, the amplified signal is converted back to the RF domain. The RF Spectrum analyser detects an additional gain due to the RFA amplification.

The SBS with high Q and small bandwidth makes this configuration very attractive for application requiring precise selection and amplification. Nevertheless, some applications require more bandwidth, such as wide pass filters. For such amplification, the bandwidth of the filter should be increased, and this can be shown by using a pump of wide bandwidth. The bandwidth of the proposed TMWPF is controlled by using RF mixing after a tuneable laser. The RF up-conversion employs a 1MHz to 5MHz square wave Local Oscillator (LO) with an Immediate frequency (IF) of pure sine signal that can be varied from 0.02GHz to 40GHz (instrument limitation). Setting the square wave frequency to 750KHz results in a filter bandwidth of 21MHz, which can be increased to 36MHz by setting the square wave frequency to 5MHz. It should be noted that the square wave's mixing resulted in more bandwidth control as compared with sine and triangular waveforms. Following the RF mixing, the signal is then amplified by RFA to obtain the required power level of the RF input for the MZIM. The output light from the MZIM is used to generate the pump signal. As

can be seen from the Fig. 1, the MZIM is placed between the tuneable laser and the circulator's input 1 to control the TMWPF bandwidth. The same technique can be extended to create a multiband SBS filter that can extract multiple bands in Wavelength Division Multiplexing (WDM) or Radio over fibre (RoF) systems. The carrier centre frequency can be calculated as follows:

$$f_p = f_{PC} - f_{LO} + f_{TPR} \quad (5)$$

Whereas f_{PC} is tuneable laser frequency, f_{LO} is local oscillator frequency of square waveform ranging from 1MHz to 5MHz and f_{TPR} is IF frequency at the mixer in GHz range and by operating the MZIM at minimum, it produces the pump signal which produces the SBS. The frequency values for square wave can be ignored (Low Frequency less than 5MHz) for amplification of a 23.4GHz RF signal as it is used to increase bandwidth. After substituting the values for pump laser, pump RF, Brillouin shift, and fixed laser in eq. [2], hence the f_{TPR} :

$$\begin{aligned} f_{MWP} &= f_p - f_B - f_c \\ f_{MWP} &= f_{PC} - f_{LO} + f_{TPR} - f_B - f_c \\ 0.0234 &= 193.4074 - f_{TPR} - 0.0108 - 193.404 \\ f_{TPR} &= 193.4074 + 0.0234 - 0.0108 - 193.404 \\ f_{TPR} &= 0.016\text{THz} \quad (6) \end{aligned}$$

From eq. (6), the MZIM RF signal should be set at 16GHz, and the tuneable laser frequency should be set at 193.4074THz. Both can be adjusted to produce amplification. The bandwidth is controlled by varying the f_{LO} frequency and signal type, which can be square, triangle, or sine. The same principle can be used to create a dual band filter by mixing two IF frequencies and employing a high power EDFA or high Brillouin gain medium, such as Chalcogenide glass or highly nonlinear fibres. By employing Erbium Ytterbium Doped Fibre Amplifier (EYDFA), the results obtained for bandwidth control can be further increased from 40MHz to 100MHz.

III. RESULTS & DISCUSSION

The proposed filter was tested for RF amplification up to 32GHz due to our available spectrum analyser maximum measuring limit. The proposed TMWPF spectrum range is only limited by component availability, which in this case was the RF spectrum analyser, however in the optical domain it was tested up to 40GHz, which is the maximum bandwidth limit of the modulators used in the system configuration. The RF signal is phase modulated using a phase shifter and biasing points to achieve 0 and π phase modulation using the I-Q DPMZM. Due to the phase difference, no RF signal or harmonics are produced at the photodiode's output. Since PM sidebands have a phase difference of π , then when they multiply/beat with the carrier at direct photodetector cancel each other. As a result, no PM signal is detected at the output of direct photodetector unless the SBS from the tuneable laser pump falls on the RF signal. This SBS signal amplifies and forces the phase modulated sidebands out of phase with each other, leading to RF signal amplification. The proposed TMWPF has a bandwidth of about 20MHz

(without bandwidth enhancement).

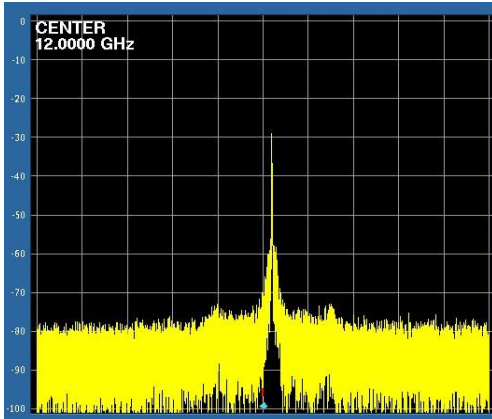

Figure 2 TMWPF gain for Ga-As I-Q DPMZM at 12GHz RF input signal. x scale 15MHz per square, y scale 10dBm per square

The noise, which is additional SBS from harmonics and carrier can be kept low if the power levels and bias point are accurately controlled. Similarly, having good frequency locking between both lasers can decrease the phase noise in the gain. The SBS amplification is controlled by adjusting the current of the EDFA, and thus the power of the pump can be fully controlled. The tuneable laser power is approximately 10dBm which enters to the MZIM, and the MZIM output is amplified by the EDFA which enables the SBS generation at the SMF.

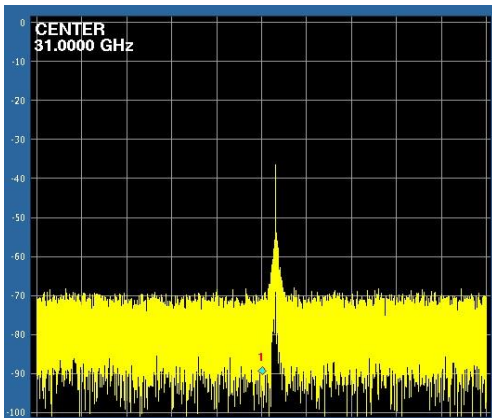

Figure 3 TMWPF gain for Ga-As I-Q DPMZM at 31 GHz RF signal input, x scale 15MHz per square, y scale 10dBm per square

A high power EDFA is preferred. But in this case, two stages of EDFA are used to amplify the sideband, exceeding 14dBm for generating a high gain SBS at the SMF. The IF and LO mixer signals are amplified by RFA to 20dBm level. As shown in Fig. 2, the SBS filter can select and amplify a 12GHz phase modulated signal. The RF signal is modulated by GaAs I-Q DPMZM and amplified from -73dBm to -29dBm. Without the SBS amplification turned on, no output appears after the photodiode due to phase modulation. The response for a 31 GHz RF signal after SBS amplification is shown in Fig. 3, where the RF signal is amplified from -70dBm to -36dBm, resulting in 36dBm gain. The decrease in gain can be attributed to the modulator and spectrum analyser reaching their

maximum operating points, which results in high losses. By using I-Q DPMZM as a PM, the harmonics can be minimized. The bandwidth in Fig. 2 to Fig. 10 is 150MHz.

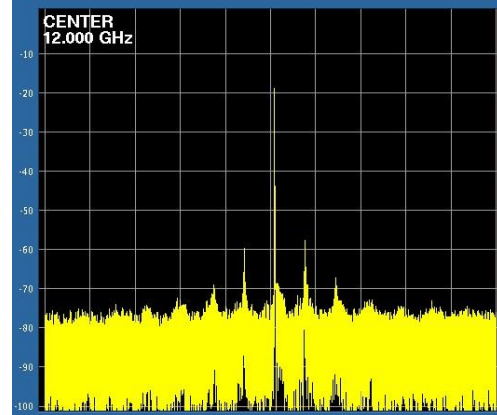

Figure 4 TMWPF gain for LiNbO3 phase modulator at 12 GHz RF input signal, x scale 15MHz per square, y scale 10dBm per square

Similarly, Fig. 4 depicts the SBS filter response for the LiNbO3 Phase modulator, which shows that the 12GHz signal is amplified from -73dBm to -19dBm, yielding a large gain of 54dBm. Due to the single drive mechanism or simpler construction of the LiNbO3 modulators used in this experiment, they produce higher output levels due to low insertion losses when compared to the GaAs I-Q DPMZM. The response of TMWPF for a 31GHz of RF input from PM is presented in Fig. 5, where the signal is amplified with a gain of 39dBm from -70dBm to -31dBm. The proposed experiment based on SBS does not only amplify the RF signal, but it also converts the phase modulated signal to intensity modulated signal by impacting the phase modulation, resulting in higher signal at the direct detection photodiode. Fig. 6 depicts the SBS filter response of an amplified intensity modulated signal from the LiNbO3 modulator at 12GHz. As can be seen, the 12GHz signal has been amplified by 46dBm, from -63dBm to -17dBm. Similar amplification extent has been shown in Fig. 7, where a 31GHz signal is amplified by 44dBm. The gains for higher frequencies are lower for all modulators since photodetectors response is lower at high frequencies as well as the wires used to transmit higher frequencies use SMA connectors which does result in RF losses for higher frequencies. The I-Q DPMZM produced lower gains compared LiNbO3 PM due to high insertion losses. The RFA is used to boost the gain by another 20dBm, yet the SBS amplification is required before using RFA, since RFA alone did not result in significant amplification. The microwave amplifier alone exhibits a gain of only 5dBm. However, when it has been used after SBS amplification, it resulted in an additional 20dBm amplification, reaching a 70dBm total amplification. The output of TMWPF for a 12GHz RF input with the RFA used for I-Q DPMZM biased for PM is shown in Fig. 8. In this case (Fig.8), by using the RFA with SBS, the gain has been increased to 63dBm when the RFA is enabled for the 12GHz RF input signal. It amplifies the small phase noise components and other acoustic side modes. The phase noise components are produced by all real oscillators and phase noise components spread the power of the

signal to adjacent frequencies, producing noise sidebands.

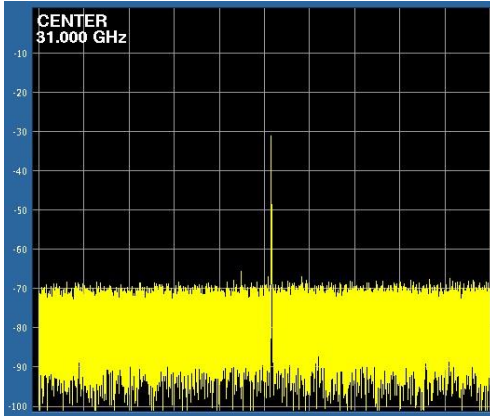

Figure 5 TMWPF gain for LiNbO3 PM at 31 GHz RF signal input, x scale 15MHz per square, y scale 10dBm per square

It is clear from Fig. 8 that PM contributes to the sidebands noise, and RFA amplifies the noise of the sidebands further. Fig. 9 illustrates obtained measurement results of a 12GHz RF input signal from the LiNbO3 PM amplified by TMWPF with the SBS and RFA. As can be seen the output is increased to 0.1dBm. The obtained gain is equal to 70dBm.

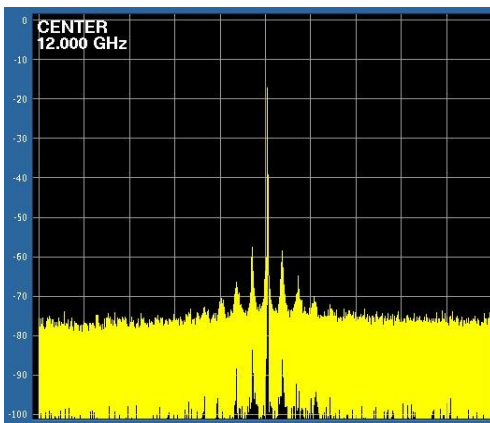

Figure 6 TMWPF gain for LiNbO3 intensity modulator at 12 GHz RF input signal, x scale 15MHz per square, y scale 10dBm per square

The noise harmonics are as a results of PM signal harmonics amplified by RFA to suppress the harmonics. The SBS gain and RFA gain can be controlled to minimise the harmonics transfer from SBS gain to RFA. Similarly, the intensity modulator outputs amplified by TMWPF with RFA turned on are illustrated in Fig. 10 where a gain of around 60dBm is achieved. The output has much cleaner noise floor as compared to PM and I-Q amplification. The bandwidth control of the TMWPF for 1MHz and 5MHz square wave local oscillator signals, is presented in Fig 11. The bandwidth of the SBS filter is set to 25MHz by using a 1MHz square wave, which can be reduced close to 20MHz by further decreasing the frequency. The square wave LO frequency is increased to further increase the TMWPF bandwidth. As shown in Fig. 11 the TMWPF bandwidth is increased from 25MHz to 35 MHz, which can be increased further if the frequency of the LO is increased further and more Brillouin gain is achieved using longer length fibre or high power EDFA. Since the bandwidth and frequency of the

TMWPF can be tuned simultaneously, this filter would have great potentials for future advanced communication systems.

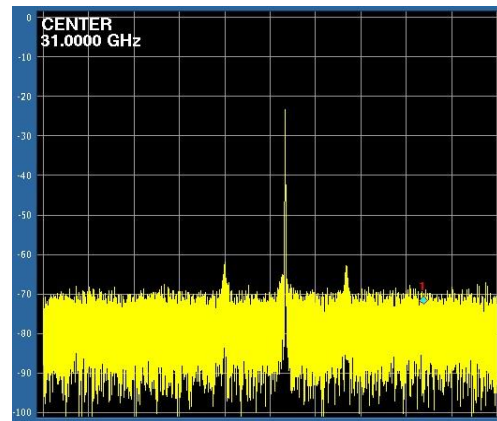

Figure 7 TMWPF gain for LiNbO3 intensity modulator at 31.5GHz RF input signal, x scale 15MHz per square, y scale 10dBm per square

Fig. 12 illustrates the TMWPF frequency response as a function of power. As can be seen from the graph, the obtained filter gain for I-Q DPMZM of 42dBm, 44dBm, 41dBm, and 33dBm is achieved at 4, 12, 24, and 31.5 GHz, respectively.

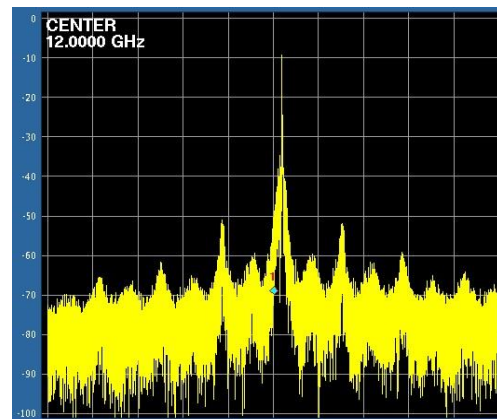

Figure 8 TMWPF gain for I-Q DPMZM at 12 GHz input signal amplified by SBS and RFA, x scale 15MHz per square, y scale 10dBm per square

The I-Q DPMZM is biased as PM. High SBS gain is observed up to 22GHz, then it drops to 31dBm at 32GHz due to the modulator insertion losses and output signal losing good phase modulation. Even though a maximum RF-based input of 20dBm is applied across the RF terminals of the I-Q modulator, the output optical power is quite low when compared to lower frequencies. The photodetector also approached its maximum bandwidth limit, and as a result its output tends to be lower at higher frequencies. The highest calculated Q factor of the proposed TMWPF is 1240. This can be compared with the best passive lump element RF filters Q of low few 100's. The SBS power is amplified by increasing the EDFA current, where the gain of the selected signal increases, reaching its maximum at around 600mA EDFA current. At 600mA the SBS gain is saturated and by further increasing the EDFA current no additional amplification is observed. It can be seen from graph that PM achieved gains of 51dBm, 54dBm, 49dBm, and 39dBm for 4GHz, 12GHz, 24GHz, and 31.5GHz frequencies, respectively. As it can be observed the highest gains have been achieved for LiNbO3 PMs.

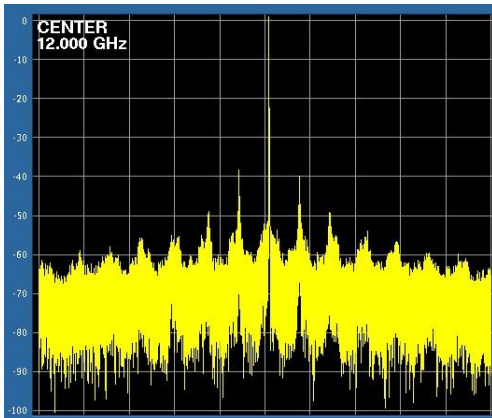

Figure 9 TMWPF gain for LiNbO₃ phase modulator at 12GHz RF input signal amplified by SBS and RFA, x scale 15MHz per square, y scale 10dBm per square

The IM achieved gains are 33dBm, 32dBm, 32dBm, and 31dBm at 4GHz, 12GHz, 24GHz, and 31.5GHz, respectively. These IM outputs and lower gain are due to the direct photo detection. Direct photodetectors are more responsive for IM, and this is the main reason why high IM outputs are produced, even when TMWPF SBS is turned off. However, RFA does also contribute slightly to the noise level in the channel. As can be seen from this figure, the highest gain of 70dBm has been achieved for PM LiNbO₃.

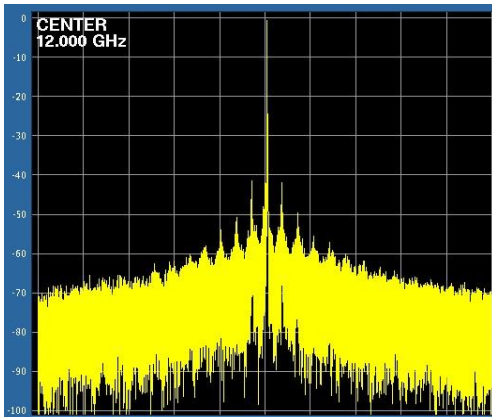

Figure 10 TMWPF gain for LiNbO₃ intensity modulator at 12GHz RF input signal amplified by SBS and RFA, x scale 15MHz per square, y scale 10dBm per square

The TMWPF amplified IM signals at same levels as it amplified the PM, but due to direct photodetection the achieved gain for IM is less than for PM. The achieved gains for IM are around 52dBm. Furthermore, the LiNbO₃ PM has demonstrated higher gains than the I-Q DPMZM, since I-Q DPMZM have high insertion losses. The level of noise floor is around 72dBm, as shown in Fig. 13. The presence of harmonics and phase noise from TMWPF can be minimized by adjusting the SBS gain and bias points. The use of the RFA increases the noise floor by 5dBm i.e., for 4GHz frequency, noise floor increased from 73dBm to 68dBm by turning on the RFA. The RFA can be turned off or removed completely if no additional gain is required. The bandwidth of the proposed filter is kept constant at 20MHz for above obtained results. The RFA values are only shown up to 18GHz due the RFA limitation. The optical domain

response of the TMWPF is presented in Fig. 14. A 40GHz PM modulated signal from the I-Q DPMZM is shown in black.

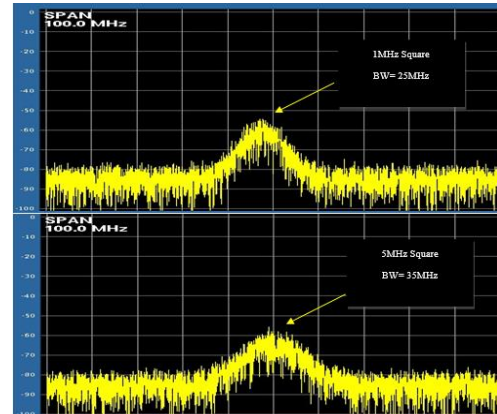

Figure 11 TMWPF bandwidth for 1MHz vs 5MHz LO square wave mixing, x scale 10MHz per square, y scale 10dBm per square

The filter bandwidth is kept constant at 20MHz. The pump laser is tuned to enable the shifted Brillouin wave to fall in one of the modulated signal sidebands. As a result, it amplifies the sidebands and a 40GHz RF amplification is observed.

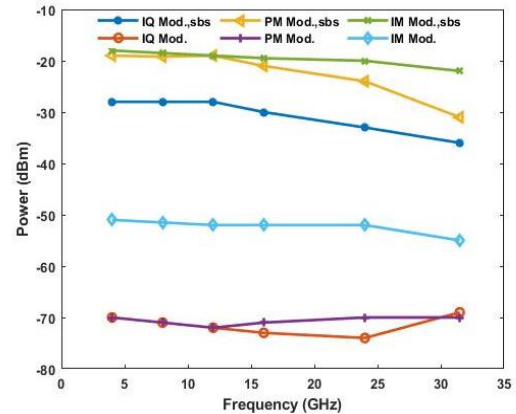

Figure 12 TMWPF response for I-Q DPMZM, PM, and IM

The pump laser also enables the sidebands to be out of sync with each other, resulting in additional amplification (PM to AM). Only Stokes are used to realize the amplification; anti-Stokes have lower amplitudes since the majority of the SBS in optical fibres are in the backward direction. Nevertheless, anti-Stokes can be used to realise the amplification (PM to AM). The EDFA controls the SBS gain. On the other hand, if we push further to realize even higher gains, the EDFA would contribute to increase the noise floor and therefore it would impact the overall Spurious-Free Dynamic Range (SFDR) of the optical channel. The TMWPF optical domain response for bandwidth control is illustrated in Fig. 15. The PM modulated RF signal of 23.4GHz is shown in black. It can be noted that the gain is amplified by using the tuneable laser based on MZIM pump. One of the SBS Stokes are tuned to fall in the 23.4GHz signal, amplifying the signal power from -25dBm to -1dBm. The tuning is accomplished by controlling the tuneable laser frequency and IF of the mixer.

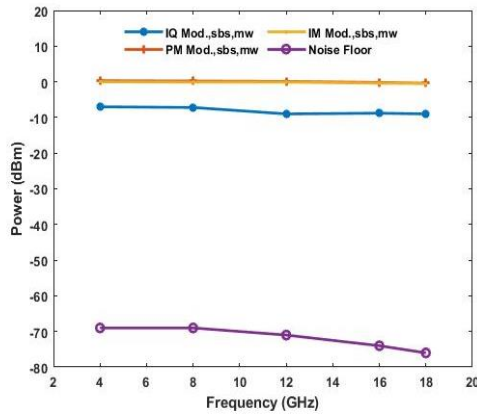

Figure 13 TMWPF response for I-Q DPMZM PM and IM with RFA

The response of the TMWPF can be improved further by employing a powerful EDFA, high Brillouin medium, and a single side band modulator.

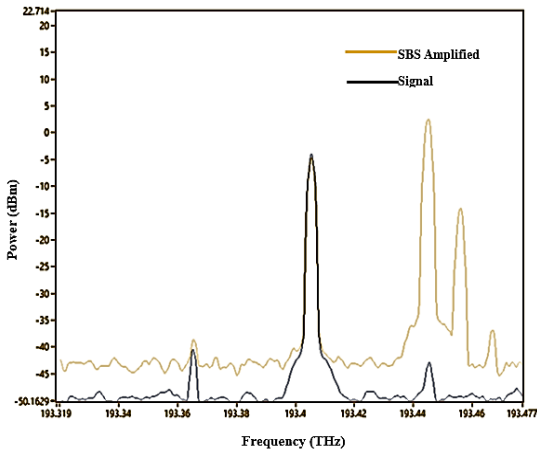

Figure 14 40GHz RF I-Q DPMZM biased as PM in optical domain (IDA Photonics OSA Image)

One of the challenging tasks of the proposed filter is locking the lasers wavelengths since both lasers are independently controlled and a small deviation may result in GHz frequency deviation.

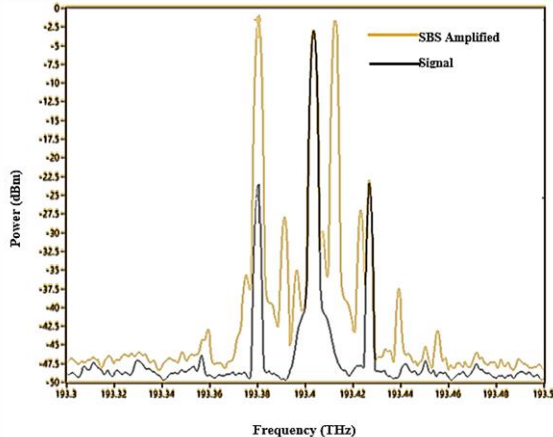

Figure 15 23.4GHz RF PM signal in optical domain (IDA Photonics OSA Image)

The filter response deviates over time due to frequency deviation caused by temperature and other factors controlling laser diodes. Another challenge factor in realising the proposed filter is the accuracy of the I-Q DPMZM biasing point control, which drifts over time, resulting in a shift between phase modulation and intensity modulation. To alleviate these challenges, a bias controller capable of handling precise specific biasing point can be used. The challenge of laser wavelength inaccuracy can be solved by using accurate electronic feedback and a photodiode. They can be locked to each other with photodiode using electronic feedback loop. It also ensures that the bias point of the modulator is precisely controlled to solve modulator drifting hitches. The system can be miniaturized to approx. 50cm x 50cm x 25cm module board. Experimental setup of the proposed TMWPF is illustrated in Fig. 16.

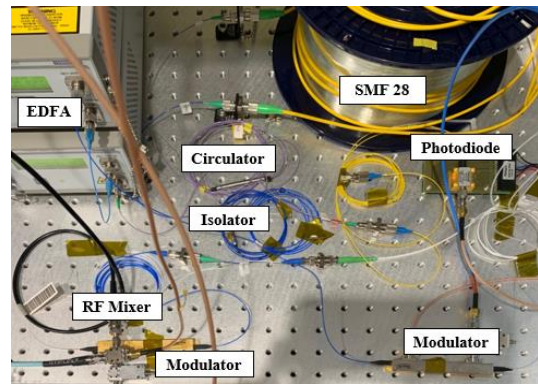

Figure 16 Experimental setup of the proposed TMWPF

IV. CONCLUSION

The experimental demonstration of a Tuneable Microwave Photonics Filter (TMWPF) based on SBS is presented. The proposed filter employs I-Q GaAs Dual parallel Mach-Zehnder Modulator (DPMZM) to generate phase and intensity modulation. The GaAs I-Q DPMZM obtained measurement results are compared and analysed with phase modulator and an intensity modulator. The use of GaAs I-Q DPMZM enabled the control of 6dBm gain as well as a complete SBS gain control via EDFA. Radio Frequency Amplifier (RFA) is deployed in the filter system configuration to achieved additional required amplification. A total gain of up to 70dBm has been obtained by applying the RFA after SBS gains in TMWPF, while Stimulated Brillouin gains of 33dBm, 57Bm and 44dBm have been obtained without the RFA amplification for intensity modulators, phase modulators and GaAs I-Q DPMZM, respectively. The RF response is produced and tested up to 32GHz, while the optical output is demonstrated up to 40GHz. The TMWPF bandwidth has been tuned from 20MHz to 40MHz using RF mixing. In the case of the GaAs I-Q DPMZM, the filter is dependent on the biasing point of the modulator, as well as the accuracy of the fixed and tuneable lasers. The proposed and demonstrated TMWPF would have applications in Wavelength Division Multiplexing (WDM), Radio over Fibre (RoF), ultra-high-speed optical communication systems,

and 6G and beyond applications due to its high gain, high Q, tuneability and narrow tuneable bandwidth.

REFERENCES

- [1] J. Capmany, B. Ortega, and D. Pastor, "A tutorial on microwave photonic filters," *J. Lightwave Technol.*, vol. 24, pp. 201–229, 2006.
- [2] D. Sadot and E. Boimovich, "Tuneable optical filters for dense WDM networks," *IEEE Commun. Mag.*, 36, pp. 50–55, 1998.
- [3] Y. Yu, et al., "Single passband microwave photonic filter with continuous wideband tunability based on electro-optic phase modulator and Fabry–Parot semiconductor optical amplifier," *J. Lightw. Technol.*, vol. 29, no. 23, pp. 3542–3550, Dec. 1, 2011.
- [4] A. Loayssa, J. Capmany, M. Sagues, and J. Mora, "Demonstration of incoherent microwave photonic filters with all-optical complex coefficients," *IEEE Photon. Technol. Lett.*, vol. 18, no. 16, pp. 1744–1746, Aug. 15, 2006.
- [5] M. Sagues, A. Loayssa, and J. Capmany, "Multitap complex-coefficient incoherent microwave photonic filters based on stimulated Brillouin scattering," *IEEE Photon. Technol. Lett.*, vol. 19, no. 16, pp. 1194–1196, Aug. 15, 2007.
- [6] J. Sancho, et al., "Dynamic microwave photonic filter using separate carrier tuning based on stimulated Brillouin scattering in fibers," *IEEE Photon. Technol. Lett.*, vol. 22, no. 23, pp. 1753–1755, Dec. 1, 2010.
- [7] B. Vidal, M. A. Piqueras, and J. Martí, "Tuneable and reconfigurable photonic microwave filter based on stimulated Brillouin scattering," *Opt. Lett.*, vol. 32, no. 1, pp. 23–25, Jan. 2007.
- [8] Gong, Jw., Li, Xj., Tan, Qg, et al., "Bandwidth-reconfigurable single-passband microwave photonic filter based on stimulated Brillouin scattering" *Optoelectron. Lett.* 15, 11–15, 2019.
- [9] W. Wei, L. Yi, Y. Jaouën, Y. Dong and W. Hu, "An ultra-flat rectangular optical filter based on stimulated Brillouin scattering in fibre," 2014 The European Conference on Optical Communication (ECOC), Cannes, France, pp. 1-3, 2014.
- [10] Li Z, Zhang Z, Zeng Z, Yuan J, Zhang S, Zhang Y, Zhang Z, Liu Y, "Tuneable dual-passband microwave photonic filter with a fixed frequency interval using phase-to-intensity modulation conversion by stimulated Brillouin scattering," *Appl Op.* 10, 58(8), pp. 1961-1965, 2019.
- [11] Zhang W, Yao J. "On-chip silicon photonic integrated frequency-tuneable bandpass microwave photonic filter," *Opt Lett.*, Aug. 2018.
- [12] Ruichen Tao, Xinhuan Feng, Yuan Cao, Zhaohui Li, and Bai-ou Guan. "Widely Tuneable Single Band pass Microwave Photonic Filter Based on Phase Modulation and Stimulated Brillouin Scattering," *IEEE Photon. Technol. Lett.*, vol. 19, no. 13, Jul. 2012.
- [13] Temple, S., 2021. *6G for policy makers*. [online] Theiet.org. Available at: <<https://www.theiet.org/media/7721/6g-for-policy-makers.pdf>> [Accessed 15 April 2021].
- [14] Mirza, T, Haxha, Dayoub, I "A Linearized Analog Microwave Photonic link with an Eliminated Even-order Distortions," *IEEE Systems Journal*, pp. 1-9, 2021.
- [15] S. Shaqiri, S. Haxha, T. Mirza, "Elimination of odd and even intermodulation distortions of analog microwave photonics link based on GaAs MZMs," *Optics Express*, vol. 28, no. 12, pp. 17521-17531, 2020.
- [16] F. Paloi, S. Haxha, T. Mirza, M. Alom, "Microwave Photonic Down conversion with Improved Conversion Efficiency and SFDR," *IEEE Access*, vol. 6, pp. 8089-8097, 2018.
- [17] X. Yao, "Phase-to-amplitude modulation conversion using Brillouin selective sideband amplification," *IEEE Photonics Technology Letters*, vol. 10, no. 2, pp. 264-266, Feb. 1998.
- [18] R. Walker, et al. "50GHz gallium arsenide electro-optic modulators for spaceborne telecommunications." *International Conference on Space Optics*, vol. 11180, 2019.
- [19] Thorlabs.com. 2021. Fiber-Coupled, Benchtop Tuneable Laser Sources. [online] Available at: <https://www.thorlabs.com/newgrouppage9.cfm?objectgroup_id=9997#ad-image-0> [Accessed 6 February 2021].
- [20] U. Schünemann, H. Engler, R. Grimm, M. Weidemüller, and M. Zielonkowski, "Simple scheme for tuneable frequency offset locking of two lasers", *Review of Scientific Instruments* 70, pp 242-243, 1999.
- [21] Zhang W, Minasian R A. "Widely tuneable single-passband microwave photonic filter based on stimulated Brillouin scattering," *IEEE Photonics Technology Letters*, 2011.
- [22] A. Villafranca, J. A. Lázaro, Í. Salinas, and I. Garcés, "Stimulated Brillouin scattering gain profile characterization by interaction between two narrow-linewidth optical sources," *Opt. Express* 13, pp 7336-7341, 2005.
- [23] R. H. Stolen, "Polarization Effects in Fiber Raman and Brillouin Lasers," *IEEE Journal of Quantum Electronics*, vol. QE-15, no. 10, pp. 1157-1160, Oct 1979.

Mian Ali is pursuing a PhD in Electronic Engineering from Royal Holloway, University of London. He worked as senior Lecturer in Electrical Engineering department, Bahria University, Islamabad for more than three years. He has completed his MSc Electronic Engineering with distinction from University of Bedfordshire, United Kingdom and Bachelor of Electrical Engineering with specialization in Electronics from Bahria University, Islamabad. His research is focused on third order non linearities in optical medium and exploiting them for applications such as delay lines, filters, amplifiers, and control. Before beginning Doctorate. His research interest includes Microwave photonics, Optical non linearities, Artificial intelligence, Optical FDM, Optical MIMO systems, Speckle Pattern-based devices, and systems for cybersecurity applications. He has published papers based on Artificial Intelligence, Antenna Design, Bio Medical Devices and Internet of Things.

Dr. SHYQYRI HAXHA (SM'14) received the MSc and PhD degrees from City University in London in 2000 and 2004, respectively. He has also obtained several world-class industrial trainings and diplomas such as Executive MBA Cambridge Judge Business School and Mini Telecom MBAs. He was awarded the SIM Postgraduate Award from The Worshipful Company of Scientific Instrument Makers in Cambridge for his highly successful contribution in research. Currently, he is a Reader at Royal Holloway, University of London, Department of Electronic Engineering Egham, Surrey, United Kingdom. He was also a Reader in Photonics in the Computer Science and Technology, University of Bedfordshire, Luton in the United Kingdom. Prior to these posts, he was a lecturer in Optic Communication at the School of Engineering and Digital Arts, University of Kent, Canterbury, United Kingdom.

Dr Haxha expertise is focused on designing and optimizing, photonic and microwave devices, and systems for applications in Sensor Technology (Medical and Environmental), Nanotechnology and Telecommunication Systems. Dr Haxha research interests are in the areas of microwave photonics, photonic crystal devices, metamaterials, photonic crystal fibres, nano-sensors, optical sensors, surface plasmon polaritons (SPP), biosensors, ultra-high-speed electro-optic modulators, compact integrated optic devices, Optical CDMA, Optical FDM, and Optical MIMO systems. He has developed and demonstrated RF over fibre transmission systems for the aviation industry, including cybersecurity protection for commercial and defence applications. He is a Chartered Engineer (CEng), Senior Member of the Institution of Electrical and Electronics Engineers (Senior MIEEE), Fellow of the Higher Education Academy (FHEA), Editorial Board Member for MDPI journals and Associate Editor of IEEE Sensors Journal. He has been a keynote speaker of numerous world class conferences.

Prof. Ian Flint received his BSc in Physics with Maths from Reading University, in 1975. In 1982, he received his PhD from Reading University on "The electron spin resonance of low temperature irradiated diamond". Prof. Ian Flint is a visiting Professor at Royal Holloway University London. He was the first to identify the role of self-interstitials to enhanced diffusion of impurities. He is a physicist, previously working for 10 years in the Universities of Reading (1978 year to 1982), Hull University (from 1982 to 1983) Oxford University (1983 to 1985) Bath University (1985 to 1989) and on optoelectronics and Solid-State physics. In 2004 Prof. Flint received BAE Systems Chairman's Gold individual award for a photonic microwave filter design. Prof. Flint is inventor of Seventeen filled patents for three different companies in the last 20 years. He is the inventor of large number of patents filing awards within Marconi Optical Components, Selex (Leonardo), Marconi, E2V, BAE systems. Patents are filed in RF sampling and RF down conversion, Laser Hybridisation; Laser machined waveguides; Integrated Optical Isolators Micro Mechanical devices; Blowing fibre into coil winding; Monitoring surface properties; In situ waveguide deposition; Microwave photonic filters; Multi Input receiver, RF Sampling; Simulated Brillouin Scattering, Imaging Devices and Systems etc.