

INVENTORY LOCATING WITH QUUPPA: THE DESIGN AND DEVELOPMENT  
OF A REAL-TIME PROCESS MONITORING WEB APPLICATION SOLUTION

A Senior Project submitted to  
the Faculty of California Polytechnic State University,  
San Luis Obispo

In Partial Fulfillment  
of the Requirements for the Degree of  
Bachelor of Science in Industrial Engineering

by

Dylan Moreland, Trevor Howell, John Takiff, Patrick Dillon, Theo Fritz, and William McIntyre

June 2021

© 2021 Dylan Moreland, Trevor Howell, John Takiff, Patrick Dillon, Theo Fritz, and William  
McIntyre

## ABSTRACT

### INVENTORY LOCATING WITH QUUPPA: THE DESIGN AND DEVELOPMENT OF A REAL-TIME PROCESS MONITORING WEB APPLICATION SOLUTION

Dylan Moreland, Trevor Howell, John Takiff, Patrick Dillon, Theo Fritz, and William McIntyre

Viasat, Inc. requires precise inventory tracking at their production facility in San Diego, CA. Viasat has installed the Quuppa indoor real-time locating system (RTLS), which it uses to track the real-time position of high-value work-in-process items. In its current state, the system only displays in-the-moment location information, with no available functionality for storing historical data for review, analysis, or visualization. In addition, the data displayed is noisy and prone to significant random error. This paper provides an overview of RTLS methods and technologies, assesses alternative solutions to Viasat's issue, demonstrates our RTLS integrated web app solution, analyzes its impact, and offers recommendations for future development.

## ACKNOWLEDGMENTS

### **Dylan Moreland**

I would like to extend my greatest appreciation to Riley Elliott, our team's contact at Viasat, for his exceptional response time, honest and open communication, and high expectations. Without his support and guidance, this project would not have been possible.

I want to thank Tali Freed for her continuous support in this project, her specific and helpful feedback, and her willingness to make time for our team despite her extraordinarily busy lifestyle.

I also would like to thank my parents, Karen Moreland, Alexa Morris, Jeff Moreland, and Maria Moreland, for their continued support in my pursuit of higher education.

I want to thank my best friend, Jacob Siderman, for providing emotional support and an outlet for my nerdy ramblings about this project. His support allowed me to manage the stressors commensurate with completing a project of this magnitude, especially during a global pandemic, and dramatically improved my productivity and levelheadedness. His persistent offers to typeset this document in LaTeX, while wholly unnecessary, were much appreciated.

Lastly, I would be remiss if I didn't thank Trevor, John, Pat, Will, and Theo for being fantastic teammates and an absolute pleasure to work with. I hope we are able to collaborate again in the future.

### **Trevor Howell**

Firstly, I'd like to acknowledge Tali Freed for not only assisting the team extensively, but also for acquiring this awesome project for our team. The amount of relevant experience I was able to gain from the project scope Tali developed was astonishing and I'm so grateful for it.

Secondly, I'd like to thank Riley Elliot for being such an adaptive and fantastic project sponsor. Riley went above and beyond for our team, and it was much appreciated. He helped us through the kinks of the project, provided great guidance and leadership, was very prompt with responses, and gave us a plethora of life advice.

Lastly, I'd like to thank all of my wonderful teammates for being so productive, helpful, and kind throughout the project. Not only were they great teammates, but they are now all great friends of mine, and I'm so grateful the project that served as an impetus for these new friendships.

### **John Takiff**

I'd like to thank Dr. Tali Freed for her continuous support throughout the entirety of the project. There were a lot of challenges we experienced throughout the project and having her to

guide us through them was instrumental to us achieving what we did. I also appreciate her allowing us to use the full range of resource PolyGAIT has to offer.

I would also like to extend a huge thanks to Riley Elliot for being both a mentor and a sponsor for this project. Throughout, Riley guided us on how both the deliverable's design and how we went about managing our team. Without his mentorship, this project would have been much less organized and would not have achieved what we did.

Before closing, I would also like to thank my family and friends for their support and guidance throughout my time in higher education. Especially in times as turbulent as the past 5 quarters have been, having such a strong network to fall back on for support and guidance has been invaluable throughout college. And I cannot thank you enough for that.

To close, I would like to thank each of my teammates. Each member pushed the others to learn new things, challenge themselves, and have fun while doing it. We not only created a great deliverable, but also learned from each other's strengths. I couldn't have asked for a better team to work with. I wish we could have worked together in-person more, but I'm forever grateful for the hours we did spend together both online and in-person.

### **Patrick Dillon**

I'd like to thank Dr. Tali Freed for all her support in helping our team coordinate among ourselves. She was very helpful in supporting the whole team as myself and the other computer science/engineering students joined the project in winter quarter. She was a great mentor in giving us the proper advice and guidance to achieve the goals we set for our project and was very helpful in keeping us on track as we progressed through our project.

I'd also like to thank Riley Elliot in all of the support and mentorship he's provided to us throughout the scope of our project. He has done an excellent job of keeping us on track with regards to planning our technical project features, determining project feasibility, and advising us on how to integrate various project features together all while staying on top of deadlines. Riley has also personally given me excellent advice in regard to finding or building a career I'm passionate about, and I'd like to thank him for the great insight he's provided our team with regards to working in industry.

Lastly, I'd like to thank my teammates, John, Dylan, Trevor, Theo, and Will for being such a fun, positive, and motivated group of people. I personally had a great time working with and getting to know each of them. We faced a lot of challenges during this project, but we all worked together to overcome each and every hurdle. In addition to the vast amount of technical experience I've gained from this project, I've also gained some amazing friends. Thank you guys.

## **William McIntyre**

I want to thank Riley straight off for supporting us through this project. He is exactly what you want in a sponsor; sensible goals, clear critiques, and enough experience to know what is useful. Much of the same goes for Dr. Tali Freed. She was a clear authority on tracking technologies and went out of her way to provide us with the tools we needed to do the project. I'd also like to thank Dawson Knight for his tireless efforts on the conveyor.

Finally, I'd like to thank the whole team, and the computer science group especially, for making this project fun and relatively stress-free. I was happy to find that everybody was so willing to pick up each other's slack.

## **Theo Fritz**

Firstly, I would like to give a huge thanks to Riley Elliot for giving us your support as well as being a huge help in providing the computer science team with information about the Viasat system in order to ease us into the flow of the project. I appreciate the flexibility and friendliness that you showed throughout the project as well as expressing your expectations to keep us on track and motivated.

Next, I would like to express my gratitude to Dr. Tali Freed for welcoming me as well as the rest of the computer science team onboard the project, and for being very accommodating as we were caught up to speed on the many aspects that went into this project as well as granting us permission into the campus lab.

Finally, I would like to thank my fantastic teammates Dylan, John, Trevor, Will, and Patrick for being the best teammates I could ask for and for allowing me to participate in this great senior project with you all. Not only have I learned quite a lot from all of you, but I also had a great time, and I am grateful that we have all formed these bonds.

## TABLE OF CONTENTS

	Page
ABSTRACT.....	2
ACKNOWLEDGMENTS .....	3
TABLE OF CONTENTS.....	6
LIST OF FIGURES .....	7
I. Introduction and Background.....	8
II. Problem Identification.....	9
III. Literature Review .....	14
IV. Solution Design.....	20
V. Implementation Plan .....	40
VI. Next Steps .....	41
VII. Conclusions and Recommendations.....	42
REFERENCES .....	43

## LIST OF FIGURES

Figure	Page
Figure 1: Viasat Whiteboard.....	9
Figure 2: Components of Total Lead Time.....	10
Figure 3: Viasat Quuppa Dashboard - Initial State.....	11
Figure 4: PolyGAIT Conveyor System .....	12
Figure 5: The Inverse Square Law.....	16
Figure 6: AOA Diagram .....	16
Figure 7: Web app design prior to meeting with Viasat .....	23
Figure 8: Web app design after meeting with Viasat.....	25
Figure 9: Quuppa Locator installed in PolyGAIT ceiling .....	28
Figure 10: QPE server and PoE switch installed in server rack .....	29
Figure 11: Web App Requirements Flowchart 1 .....	30
Figure 12: Web App Architecture.....	31
Figure 13: Mock Manufacturing Process Tote .....	32
Figure 14: PolyGAIT Conveyor Floor Plan with Labeled Workstations .....	33
Figure 15: Web App Mainline Page .....	34
Figure 16: Web App Clinic Page.....	35
Figure 17: Web App Manager Page.....	36
Figure 18: Web App Executive Page.....	37
Figure 19: Web App IE/CI Page.....	38
Figure 20: Web App Tag Assignment Page .....	39

## **I. Introduction and Background**

Viasat's production facility located in San Diego, CA is currently having issues with inventory management. Although Viasat hasn't directly measured its current state of inventory management, it has noticed significant problems associated with its lack of effective inventory tracking, including lost and misplaced inventory and excessive employee hours dedicated to locating lost inventory. This non-value-added time spent adds to the lead time of products and negatively impacts customer goodwill. Due to these existing problems, Viasat dedicated its efforts to exploring different inventory location tracking systems. After consideration of multiple systems, Viasat decided on installing a real-time location system (RTLS) created by the brand Quuppa, a Finland-based company that specializes in the field of real-time location tracking.

Since the installation of the Quuppa system, Viasat has been having trouble achieving its desired goals with the system (mentioned in the Problem Statement below) and has requested help from us. In order to assist, we have procured and installed a Quuppa Development Kit in the PolyGAIT (Global Automatic Identification Technologies) lab on the Cal Poly campus, and we have also developed a functional dashboard to meet Viasat's requirements. To effectively develop the system, we tested it on a mock manufacturing process we have created in order to simulate the movement of inventory at the Viasat facility. The goal of this project was to create a functioning real-time inventory tracking dashboard that can be scaled and applied to Viasat's facility.



## II. Problem Identification

### Problem Statement

Viasat lacks effective inventory tracking. They are losing track of inventory and spending considerable time locating this lost inventory, which causes logistical issues. The precise amount of time lost in this process is unknown.

### Current State: Viasat

Viasat’s Carlsbad manufacturing process is currently going under a major overhaul. The Viasat facility has only just begun implementing formal inventory tracking systems within the past year. Their current system is a series of whiteboards (see Figure 1) and magnets that display where each serial number is located in the station’s process. Four times per day, the managers walk the floor. They fill out pitch charts to keep track of each station’s performance against a standard takt time and to relieve bottlenecks in the system. In addition to the manual inventory tracking with the whiteboards, workers are also required to manually confirm move transactions in 2 separate software systems – Oracle (the business/cash flow software) and Solumina (the Manufacturing Execution System, or MES). Move transactions are database entries in Solumina that indicate the transfer of work-in-process (WIP) between manufacturing workstations. Viasat’s end goal is to have this most or all of this inventory tracking operation automated by the Quuppa system.

Tests:	T1	T2	T3	Workstation: Alpha	
Queue:				Date: 11/15/2020 Completed today: 0	
Problem				In Process:	
Completed				Tech 1:	Tech 2:
				Tech 3:	Tech 4:

Figure 1: Viasat Whiteboard

In order to determine the severity of the problem, it is helpful to understand how much time is being lost in the current state of the system. Unfortunately, Viasat has not been able to track this information. The key problem (as explained by Riley Elliot, our team’s Viasat contact) is that assessing total lead time is not a very straightforward process because there are so many factors to control. The product being assembled is very intricate and requires a complex series of assembly and testing steps before it can be delivered to a customer. In our meeting on November 4th, 2020, Riley explained how the basic principles of Lean manufacturing should guide the Quuppa system’s implementation in order to most effectively improve Viasat’s manufacturing operation.

From this meeting, we learned that Viasat defines total lead time as the sum of queue time and cycle time. Queue time consists of the time a product spends waiting to be worked on, while cycle time comprises the value-added and non-value-added time spent actively working on a product. The relationships between these different metrics are illustrated in Figure 2 below. The goal of the Quuppa system is to identify the queue and cycle times for a product. Once the lead time is known, it can be compared against other Key Performance Indicators (KPIs) such as yield and scrap. Knowing lead times also allows Viasat to implement a Kanban system in which the Quuppa system triggers the next step in the operation sequence and, through Solumina integration, determines how many parts need to be made. This allows Viasat to move to a more efficient “pull” system in which parts only move to the next step in the process when the downstream step is ready to receive them. In contrast, a “push” system involves each step producing parts as fast as possible with no regard for what is happening downstream in the assembly line. This type of system causes excessive amounts of work-in-process and wastes money in the form of unnecessary labor and raw materials as the half-finished products sit in storage. In summary, it is currently difficult to see exactly what contributes to the long lead times experienced at Viasat, but by controlling the process through RTLS inventory tracking, Viasat hopes to set a baseline for future process improvement.

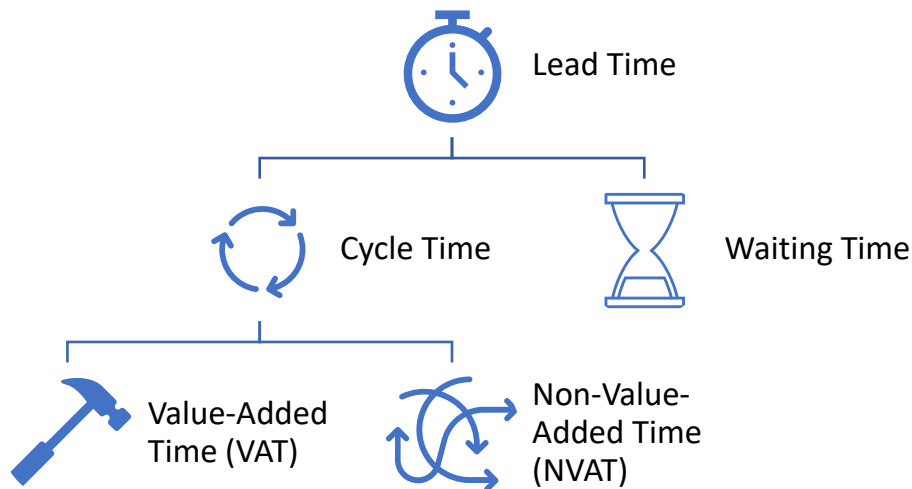

Figure 2: Components of Total Lead Time

While Viasat has deployed a Quuppa system at their Carlsbad facility, it is not yet in a usable state. The system currently displays only real-time location information, with no ability to record or review historical data. It cannot confirm when a product has entered or left an operator's workspace, and thus it cannot automate move transactions, which is one of Viasat's goals. The data in the current system is also quite noisy and requires significant data smoothing in order to be useful.

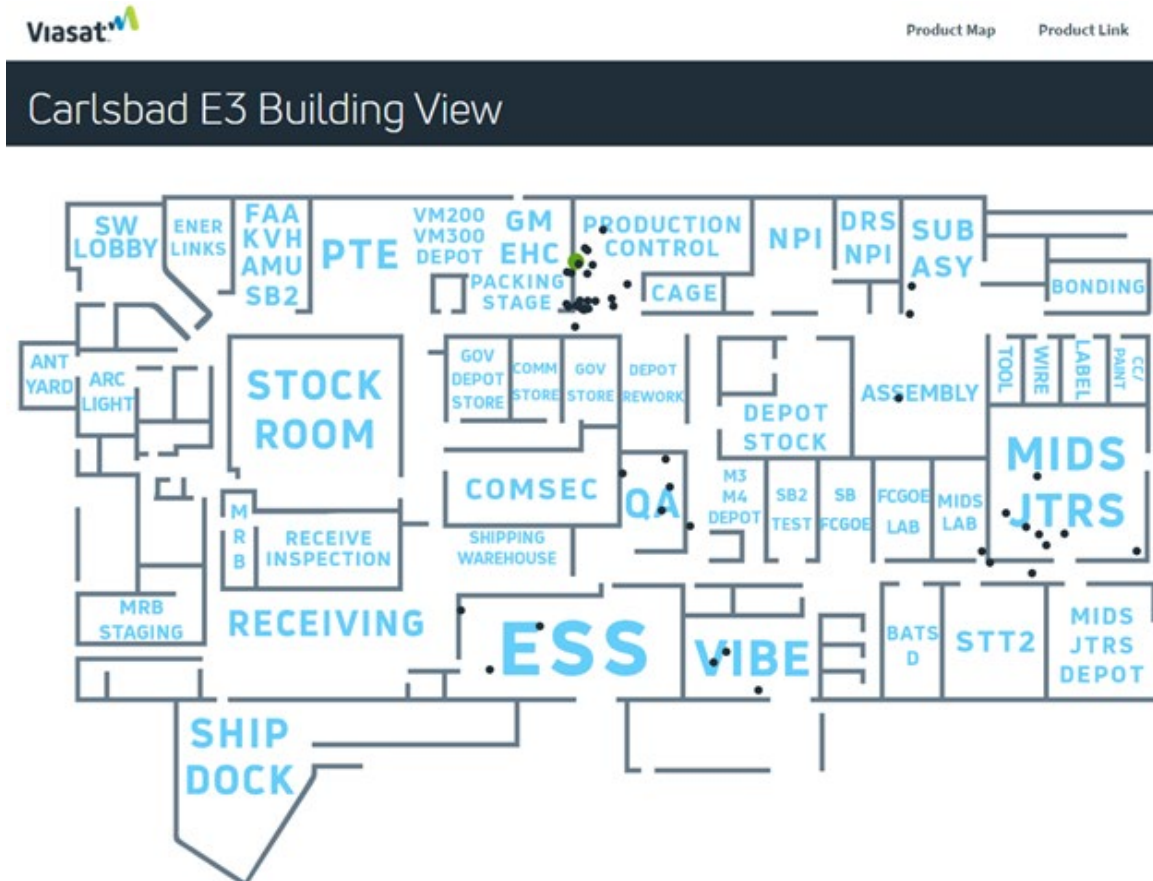

Figure 3: Viasat Quuppa Dashboard - Initial State

### Project Objectives

Viasat tasked us with developing and testing a system that accomplishes 3 key goals to solve the problems outlined above. The 3 goals were:

1. Determine how to extract data from the Quuppa system and interface it with Solumina
2. Create a system for confirming move transactions
3. Mockup metrics for cell-based manufacturing from data

Collecting accurate position data was crucial for accomplishing these goals. Working in conjunction with Cal Poly computer science students and the data science team at Viasat, we

developed a comprehensive data smoothing algorithm to reduce noise in the system, enabling more accurate location data capturing. Additionally, it was necessary to develop a manufacturing process that can be easily performed on-campus, but is sufficiently similar to the one at Viasat, to verify and validate the newly developed system. The simulated process also aided the development of metrics that accurately assess the performance of each manufacturing station. This simulated system was built at the PolyGAIT lab on Cal Poly's campus.

### **Current State: PolyGAIT Lab**

To develop a system that meets the outlined goals and solves the problem statement, we have installed a Quuppa system at PolyGAIT. PolyGAIT is Cal Poly's on-campus lab for studying, developing, and testing RTLS systems. There is an automated conveyor loop to transport items in a circle, with various attachment points for RTLS system hardware. As the items move around the conveyor, they can be tracked with the RTLS system to verify its functionality. While Viasat uses carts and not conveyors to move products, this conveyor system should make it easier for us to move the locators through a simulated manufacturing process while monitoring the Quuppa software system.



Figure 4: PolyGAIT Conveyor System

## **Cost Analysis**

Viasat has fully committed to using Quuppa as their RTLS of choice. To that end, they have sponsored Cal Poly's purchase of a Quuppa development kit for the PolyGAIT lab. Quuppa is one of the more expensive real-time location systems on the market, but it is the most robust and accurate according to our research in the Literature Review section below. This greater accuracy is worth the additional expense because when our system is deployed, accurately determining lead time will result in less product being shipped late, saving Viasat thousands in penalties as most of their government contracts have hefty penalties for late delivery. Viasat requires the utmost precision in their RTLS because they want to track at which workstation a product is worked on. These workstations could be separated by only a few feet, so Viasat's RTLS solution must have sufficient precision ( $\pm$  a few inches) to accurately track product movement. The Quuppa system will also allow for greater insight into the manufacturing process, informing future process improvements that will likely continue to reduce costs.

### III. Literature Review

#### History of Inventory Tracking

Inventory tracking and management dates back tens of thousands of years. The first evidence of inventory management was in the form of tally sticks over 50,000 years ago (History of Inventory Management Technology, 2018). Although primal, it was essential in the earliest manufacturing processes. Over time, as manufacturing scaled with the growth of population and demand, there were employees dedicated to walking around facilities manually taking count of inventory. It wasn't until the Industrial Revolution started in 1760 that production efficiency and minimizing unit costs were imperative enough (due to skyrocketing demand) to justify significant effort towards more robust inventory tracking solutions. The Industrial Revolution was an era characterized by mass production and it required more advanced and accurate inventory tracking than existed at the time. This prompted an explosion of – among other things – advanced and more robust inventory tracking systems.

Later in the Industrial Age, Herman Hollerith established himself as a pioneer in the development of inventory tracking. Regarded as the father of modern automatic computation, he invented the first punched card tabulating and sorting machines as well as the first key punch (Cruz, 2001). This machine nearly eradicated pen and paper inventory counting and saved countless person-hours previously spent manually counting and documenting inventory. This technological advancement proved so successful that it inspired development by Harvard University. In the 1930's, Harvard came out with an inventory tracking system consisting of a punch card that corresponded with catalog items and was used to generate billing as well as manage inventory (Cruz, 2001). As the most technologically advanced inventory tracking system of its time, the punch card system was widely adopted by a variety of industries and is still used today.

During the 1960s, a group of retailers came together and invented the modern barcode system to track inventory. This innovative technology created a way to encode information into a visual pattern (black lines and white spaces) that a laser can read. Barcode technology is very inexpensive and effective, motivating almost every manufacturer to adopt it. Its wide adoption made inventory tracking much more accurate, yielding significant fiscal benefits for companies. One notable drawback of the barcode system was the lack of digital storage space in the existing storage devices of the era (Bar Code Direct, 2015). This drawback sparked further development into the 1980's and 1990's. By then, databases had been created and storage devices were increasing in size at a rapid rate, paving the way for manufacturing facilities to quickly scale in size and capacity. In fact, by 2004, up to 90% of the top 500 companies in the United States used barcodes in some fashion (Barcoding, n.d.).

Another drawback of the barcode system was the lack of usable range for data transfer. Lasers weren't able to collect or transfer data from a distance. Being able to collect data from a

distance would be a pivotal improvement for speed and efficiency in inventory tracking. This need inspired the invention of Radio-Frequency Identification (RFID) in the late 1990's which is one of the most ubiquitous technologies in inventory tracking systems around the world today (Roberti, 2005). RFID technology consists of tags and tag readers which exchange electromagnetic interrogation pulses and digital data. Each tag has a unique identifying piece of data, often in the form of a serial number assigned to the individual item on which the tag is placed on (What is RFID?, 2020). This data can be read by tag readers, allowing for quick, accurate, and contactless inventory item identification. RFID replaced the barcode system in many industries due to its ability to collect inventory information from a distance. This feature allowed for inventory tracking to become much more automated and, in turn, less expensive.

## **Real-Time Locating Methods, Current Technologies, and Future Improvements**

### ***Real-Time Locating Methods***

There are a wide variety of real-time locating system methods available today, each with their own advantages and disadvantages. Many of the RTLS technologies in the Current Technologies section below use combinations of the locating methods listed here in order to produce the most accurate position measurement possible. Almost all of the methods and systems below have the same general architecture: static locator beacons mounted in known locations that connect to a computation device, and dynamic tags affixed to items of interest that are free to move about within the range of the locator beacons. The computation device compiles and analyzes data from the locator beacons' interactions with the tags, producing fairly accurate tag position data (and therefore producing data for the items to which the tags are affixed).

### ***Received Signal Strength Indicator (RSSI)***

One method of real-time locating involves the clever use of radio signal attenuation measurements. Radio waves - including Bluetooth, Wi-Fi, X-rays, and even visible light - follow a physical law known as the Inverse Square Law. The Inverse Square Law states that each time an observer's distance (d) from an electromagnetic radiation source (of strength S) doubles, the amount of electromagnetic power (P) that reaches the observer is divided by four (Subhan & Hasbullah, 2010). In other words,

$$P = \frac{S}{d^2}$$

Because Wi-Fi, Bluetooth, and other systems explored later in this section are all based on radio waves, we can use the above relationship to measure distance. By sending out a signal of a known power level from a locator beacon and asking the tags on the items of interest to report back their perceived power (also known as their Received Signal Strength Indicator or RSSI), it is possible to use the difference between the sent and received power to approximate the distance between the locators and the tags (Subhan & Hasbullah, 2010). Repeating this

process with three or more locators in different positions allows for position trilateration, similar to how the GPS receiver on a smartphone can calculate its position by locking onto at least three GPS satellites in space.

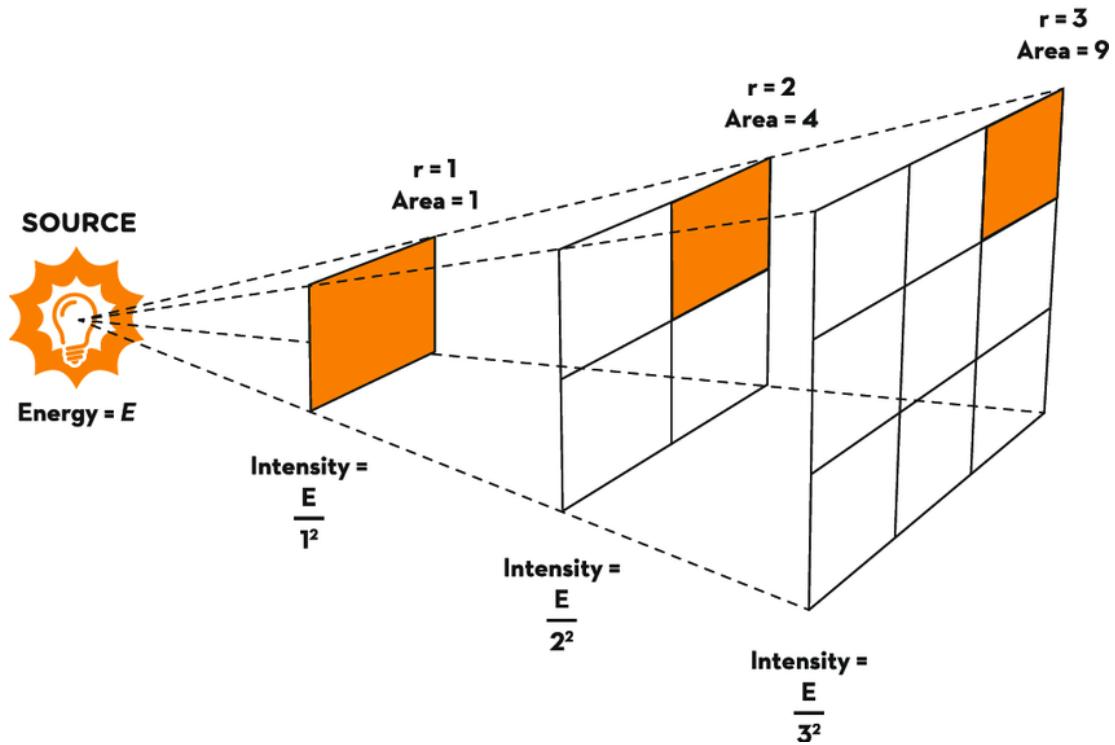

Figure 5: The Inverse Square Law

*Angle of Arrival (AOA)*

The Angle of Arrival locating method uses the angle at which the locator beacons receive signals from a tag to triangulate the tag's position. By approximating the angle between the tag and a locator beacon, and by repeating that process for several different locators in known positions, one can calculate the approximate position of the tag (Subhan & Hasbullah, 2010).

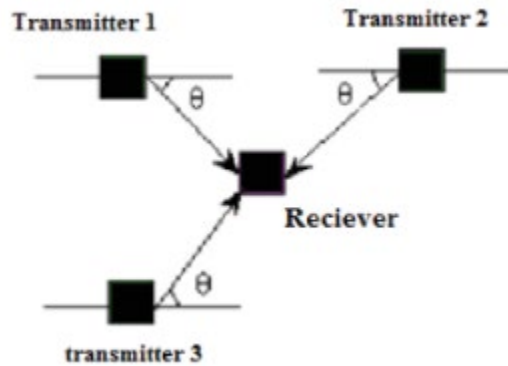

Figure 6: AOA Diagram



### *Time of Arrival (TOA) / Time Difference of Arrival (TDOA)*

Time of Arrival (TOA) calculations approximate the distance between the locator and the tag by calculating how long it takes for the signal to propagate from one to the other (Subhan & Hasbullah, 2010). Performing these measurements with multiple locators against a single tag yields the Time Difference of Arrival (TDOA) method, in which differences in the TOA calculations between the various locator-tag combinations are used to determine the tag's position in space (Subhan & Hasbullah, 2010). However, since radio waves propagate at or near the speed of light, this technique is most useful in long-distance applications, such as GPS (Subhan & Hasbullah, 2010). Indoors, the delay in signal propagation is so short that it cannot be measured precisely enough with current technology to produce accurate results.

### *Current Technologies*

#### *RFID*

RFID systems come in two main varieties: active and passive (Want, 2006). Active systems require the tags to have a built-in power source, which adds an additional maintenance requirement to the system as well as another potential point of failure (if the tags run out of charge). Passive systems, on the other hand, do not require the tags to have a built-in source of power. Instead, the RF signal from the RFID reader induces enough current in the tag's antenna to power the embedded circuit and transmit the tag's unique identifier back to the reader. Because they have no built-in batteries, passive RFID tags require no maintenance and can be made much smaller and much more cheaply than their active counterparts (Want, 2006).

#### *Wi-Fi*

Wi-Fi positioning systems are an alternative to RFID. This technology involves measuring the Received Signal Strength Indicator (RSSI) of a Wi-Fi enabled device in relation to a Wi-Fi access point with a known location. According to the Inverse Square Law, every time the distance between a target and an access point doubles, the RSSI decreases by a factor of four. This technique yields a rough approximation of the device's distance from the access point. By combining RSSI calculations from multiple access points, the target device's position can be approximated by triangulation (Vaupel, Seitz, Kiefer, Haimerl, & Thielecke, 2010). Wi-Fi is an attractive solution due to the ubiquity of Wi-Fi access points in most modern indoor spaces. Unfortunately, while Wi-Fi triangulation can provide coarse, infrequent location tracking functionality, it cannot meet the precision or update interval requirements necessary to be used as a Real Time Location System (RTLS) (Pancham, Millham, & Fong, 2020).

#### *Bluetooth*

Bluetooth Low Energy (BLE) uses a similar RSSI-based triangulation system as Wi-Fi positioning systems, but it has the key advantage of using far less power due to the narrower frequency bandwidth it uses (2 MHz) as compared to Wi-Fi (20 MHz) (Faragher & Harle, 2015).

A distinct advantage of BLE over traditional Bluetooth systems (Bluetooth versions less than 4.0) is that BLE is able to scan and identify neighboring devices much more quickly than traditional Bluetooth. A study performed with a traditional Bluetooth system demonstrated that a scan could take upwards of 10 seconds to complete. During that time, a target device to be tracked could move a considerable distance in a busy warehouse, so this system does not have the necessary update speed required to produce accurate results in fast-paced environments. By contrast, the scanning delay in BLE is so short as to be negligible (Faragher & Harle, 2015).

### *Ultra-wideband*

Ultra-wideband (UWB) gets its name from its broad-spectrum design. UWB systems use a relatively large portion of the RF spectrum (compared to the other technologies listed here) in order to transmit large amounts of data with relatively little energy (Alarafi, et al., 2016). In contrast to the RSSI calculations used by other real-time locating systems, UWB uses the Time Difference of Arrival (TDOA) method to calculate position (Alarafi, et al., 2016). By measuring the minute differences between when signals from different locator beacons reach a given tag, ultra-wideband locating systems can approximate the distance from the tag to each locator and can subsequently calculate the tag's position in space.

### *Future Improvements*

Future improvements of RF-based location tracking largely consist of developing better data processing techniques to calculate positioning data more quickly and/or more precisely. Current RTLS systems require complex, resource-intensive computation systems to perform the RSSI calculation and positioning (Pancham, Millham, & Fong, 2020). By reducing the computational requirements to perform real-time location tracking, RTLS technology can become more affordable and accessible for all.

### **Benefits of Increasingly Accurate Inventory Tracking**

Increasing accuracy when tracking inventory increases savings on material costs, but it results in an increase in labor costs in manual inventory tracking systems due to the additional personnel time spent. However, modern inventory tracking systems can significantly reduce the expense of inventory tracking while simultaneously increasing its accuracy by replacing workers with automated tracking systems. Placing RFID tags on inventory items and an RFID tag reader above doorways or conveyor systems allows all items to be scanned quickly in a smooth, continuous manner, rather than needing to stop and scan each item manually (Quick, Accurate Inventory Tracking, 2001). A case study of a restaurant in Wisconsin compared the state of the restaurant before and after acquiring inventory management software. Before using the software, taking inventory had to be done by hand, and according to the restaurant owner, "it just wasn't worth the time and effort to do it" (Rodgers, 1996). The gains experienced after implementing the software allowed the company access to previously inaccessible data about material costs and demand for certain items. This data allowed them to refine their orders to match customer

demand. In a case study of a hospital, a 3% reduction in supply inventories saved ten million dollars (Chila & Susi, 2019).

In one case study of a make-to-order environment, manufacturers needed to know accurate stock levels as they attempted to outbid each other. Knowing the amount of inventory on hand and the lead times for each part had a significant impact on the final bid that was submitted to the client (Hsu, Lee, & So, 2006). Accurate inventory tracking becomes increasingly valuable as the “scale and complexity of a delivery project increases” (Ala-Risku, Collin, Holström, & Vuorinen, 2010). This particular article looked at a telecom project where they found accurate tracking reduced the breakdown of the alignment between participants, which ends in delivery operations being compromised.

It is important to recognize that implementing highly accurate systems is not a “silver bullet to solve all the problems in supply chain management” (Huang, Zhang, & Jiang, 2008). Fundamental flaws in the supply chain or in the manufacturing process will likely not be solved by a large capital investment in inventory tracking systems. However, highly accurate systems can point to problems in an operation. And once those problems are solved, the system will remain in place, safeguarding against future problems and keeping inventory tracking costs down.

## IV. Solution Design

### Solution Alternatives

#### *Barcode System*

An obvious solution to the issue of inventory tracking is the tried-and-true barcoding method. As discussed in the Literature Review under the History of Inventory Tracking section, barcoding has been commonplace since the 1960's and has proven to be a reliable and consistent inventory control method used by almost every retail store around the world.

#### *Design*

Barcoding at Viasat would consist of installing handheld barcode scanners at each workstation, as well as a barcode label maker at the beginning of the manufacturing process. Each part would be scanned when it is received at each workstation and again when it departs each workstation. By combining the ID of the barcode scanner, timestamp of the scan, and unique data on the scanned label, it is possible to determine in what manufacturing phase any given unit is in at any time.

#### *Evaluation*

Unfortunately, several key properties of a traditional barcode system make it unsuitable for Viasat's needs. First, while barcoding systems are indeed inventory control systems, they are not RTLS's. They are unable to provide the precise, authoritative location information that Viasat requires. The barcode system described above would simply indicate a part's current manufacturing phase, leaving manufacturing supervisors and data analysts blind to the part's movement within a phase and between phases. Next, while scanning a barcode takes only a few seconds, the time spent scanning barcodes across all operators over the course of a few months or a year can add up to significant amounts of non-value-added time. Barcodes are also single-use items and cannot be removed from finished goods and reassigned to new parts as finished parts leave the warehouse. Finally, a system such as barcoding that requires operators to scan each part in and out adds the potential for human error. A single missed scan or incorrect scan could drastically alter the system's understanding of where a given part is in the manufacturing process. If this system is connected to the Solumina ERP software, this could cause cascading issues throughout the manufacturing floor.

#### *Traditional RFID System*

Many manufacturing warehouses have used traditional passive RFID systems for their inventory control. Its touchless, automatic operation makes it an attractive option, and it requires minimal human intervention, reducing the probability of operator error. Passive RFID labels are also cheap and easy to print. They can serve the double purpose of identifying a part to humans via a readable label and also identifying a part to the location tracking and/or ERP system.

## *Design*

An RFID system at Viasat would be constructed in a similar fashion to the barcode system above. Instead of handheld scanners, however, RFID readers would be mounted above and/or next to the incoming and outgoing queues at each workstation. Instead of barcode labels, passive RFID adhesive tags would be affixed to each part at the beginning of its manufacturing journey. These tags would be read automatically as they pass by the readers on each end of each workstation. The collected data would feed into a part tracking and/or ERP system as in the barcode system above.

## *Evaluation*

Though an RFID system may seem flashy and attractive on the surface, it actually is quite difficult to set up correctly and – depending on the system setup – can be quite prone to errors during the tag reading process. As discussed in the RFID section above, passive RFID requires the readers to be very close (within a few inches) of the tags to be scanned in order to create sufficient magnetic coupling between the reader and tag to ensure a good read. Furthermore, differences in tag location and orientation on the part can dramatically affect the read success rate. Tags that are positioned in the wrong location or are rotated incorrectly can degrade the magnetic coupling between the reader and the tag such that successfully reading the tag data becomes impossible. In the event of a bad read, it costs considerable time and manual intervention to move the queue of incoming or outgoing parts backwards and run the affected part through the reader again for a second try. The RFID system also comes with many of the same significant drawbacks as the barcode system; of these, the most significant is the inability to track part locations in real-time.

## *Web App*

### *Design*

The design of our web app needs to integrate a number of key features to satisfy the requirements of a variety of stakeholders and to meet our client's established security and functionality standards. At the core of this solution is a web application running on a server that is accessed by the individual operators at their workstations. The web server taps into the Quuppa Positioning Engine for location data, connects with Viasat's Solumina MRP system to confirm move transactions, and integrates with the IIOT conveyor project at PolyGAIT lab (only until the solution is shipped to Viasat, at which point the conveyor connection will be removed).

Our first meetings were with Riley to understand Viasat's requirements for a deployment of web application at their facility. This included security measures and how the operators can integrate the web app into their workflow. Viasat has already deployed a simple version of a web app, so we met with the team that developed the application to understand some of the technicalities of the existing app and the technical requirements needed to maintain Viasat's security and operations standards. These meetings also helped us understand how Viasat wants

the Quuppa data streamed to the web server. We were able to obtain some code to kickstart the process and advice for parts that they couldn't send us due to NDA agreements.

As previously mentioned, one of our key goals is figuring out how to interface Quuppa data with Solumina. Specifically, we needed a system for the operators to confirm their move transactions. Viasat walked us through the process an operator currently follows, so we have a basic understanding of what this integration would require. First, the new system we are building needs to know when a unit was moved out of an operator's work area and alert the operator of this change so they can confirm it was intentional, then send the move command to Solumina. Second, the new system needs a way to track units that needed to be put into the "clinic." Ideally, workers who find defective units could record the defect in the new system, which would alert a manager who could assign the unit to a repair tech. This system creates a chain of responsibility if a product is delayed. It also allows for big-picture analysis of common problems experienced so that the continuous improvement team can focus their efforts.

Our next key meeting was meeting with Dawson Knight. Though conveyor integration was not a part of Viasat's original guidance, Tali added an additional goal of integrating with PolyGAIT's IIOT conveyor. The concept we are attempting to materialize is using the location data from the QPE to control the items on the conveyor, specifically by moving them left, right, or straight at the Workstation 1 diversion point. Dawson designed the conveyor system so that it writes binary values to a text file which represent the state of the system – whether or not the conveyor is running, the speed at which it's running, and the presence of items at each of the photo eyes located at various points around the conveyor. This text file is stored on a computer in the lab. Our web server sends HTTP requests to the lab computer to read and write to this file. In our web app, the user assigns which items need to go in which direction. The web server, which is already receiving location data, processes which items need to go where. When the item arrives at the junction, the web server fires off a HTTP request to the conveyor computer. This diverts the item in the appropriate direction. We will also need a verification system to ensure that the conveyor did not encounter any problems while diverting the item.

With these meetings, we had a good outline of what was possible with a web application. After meeting with these various groups, we drafted a preliminary plan. We reviewed it with our CS team to ensure it would all be achievable from a technical perspective, and we eventually created Flowchart 1 (Figure 7) which outlines the design of the web application's features. Flowchart 1 gave us a path forward for development of the key features of our web application. However, it did not specify how each element would be used at the level of detail that Viasat required.



The CS team then met to flush out some of the technical details based on the previous recommendations and their own experiences. The design of our web interface consists of a Bootstrap front-end framework, a PostgreSQL database, and a Python web application built with Django to interface with our database and serve pages built with Bootstrap. Our solution works by receiving JSON positioning data from the Quuppa Positioning Engine (QPE) via a UDP (User Datagram Protocol) stream. Our solution then applies an extended Kalman filter to the tag location data pulled from the stream. The filtered position is snapped to the most probable defined path or zone and passed to our database to be queried later and displayed by our web application.

### *Evaluation*

When evaluating the web application solution, most of our reasoning stems from the technical advantages a web application provides. A web application is a sufficient implementation for this solution because it can make viewing and interacting with location data simple and efficient. A web application provides a great way to see the location data because it allows for a straightforward, dynamic way to visualize the data. The Django web application also interfaces well with the PostgreSQL database, and the Bootstrap frontend framework contains some powerful visualization tools for viewing this data. Presenting the location data through a web application also allows for other users to see the location data as long as they have access to the web server, allowing a small team to manage multiple locations remotely.

One key aspect to our evaluation process was meeting with Viasat. After showing them Flowchart 1, they recommended we transform our design into an analytical hierarchy. This forced us to think about each group of users who will be using the system and what they will need. While Flowchart 1 is a great tool for showcasing our development goals, Flowchart 2 (Figure 8) better represents what the final deliverable will look like.





After compiling design ideas from the various stakeholders and turning them into a flowchart, we reviewed our cumulative design with all the stakeholders to ensure everyone was on the same page before beginning the build stage. Viasat agreed that a web application built as described in the flowcharts was the best solution. As a web application is centered around a communal server, it allowed for easy collaboration between developers, leading to lowered time to deployment. In addition, the plan forward for integrating with Solumina became much easier as only one server had to talk to Solumina as opposed to multiple clients.

### *Verification*

This system will be verified by running test scripts to ensure that historical location data can be queried and displayed correctly. This will happen by running scripts that will compare the location data presented by the website with the location data received from the QPE UDP stream, to ensure that the data from the database and website is consistent with the data streamed from the UDP stream.

The UDP stream data has been verified by viewing the JSON location data retrieved from the QPE when moving tags around the room where the RTLS system is. It can be seen that the UDP stream shows the correct location data as well as changes in the location data when a team member physically walks across the room holding one of the tags.

In order to verify the Quuppa web app solution, we will be testing the model extensively using our mock process. We will ensure that everything is operating smoothly and accurately on our simplistic process before we can scale it up. In addition, we requested and received additional locator tags from our sponsor and will be using them to further verify the effectiveness of our solution. We will be verifying not only the locational accuracy and the ability for the program to perform move transactions, but the smoothing of the data points. This will be done by performing tests in which we confine the tag to a certain area and ensure the natural drift in the tag's reported position is held to a minimum (within reason).

### **RTLS Vendor Selection**

There are two main competitors for real-time locating systems: Quuppa (based in Finland) and Pozyx (based in Belgium). Both are well-established in the RTLS field, but their slight differences were important in our analysis. Ultimately, our decision was made for us by Viasat, since they stipulated that we use the system they had already installed in their San Diego facility in our senior project. However, for the sake of thoroughness, we elected to evaluate Quuppa against Pozyx anyway.

Pozyx is a Belgian company that specializes in real-time location systems. It uses a series of permanent anchors that connect via Ethernet to a switch that provides power over ethernet (PoE). This switch connects to a gateway that then relays the data to any on-site visualization, analysis, or storage applications, as well as to the Pozyx Cloud. The gateway collects data from

the anchors and uses the Time Difference of Arrivals method (TDOA) to determine the position of the tagged items in space.

The Quuppa architecture is almost identical to that of Pozyx. It consists of permanent locator beacons connected to a PoE switch that then connects to the Quuppa Positioning Engine, which calculates the tagged items' positions in space based on the data received from the locator beacons. However, the Quuppa system uses the tags' Received Signal Strength Indicator (RSSI) values, as explained in the Literature Review section above, to calculate the tags' positions. Because of Quuppa's proprietary technology, the Quuppa system is able to achieve sub-centimeter precision, whereas the Pozyx system is only able to position tags within about 10-30 centimeters. Viasat's specifications require sub-centimeter accuracy, so for this reason, we confirmed Viasat's selection of the Quuppa system as the best fit for this project.

## **Design of Solution**

Our solution is creating a web application that displays filtered live inventory location maps along with KPIs calculated from the data collected by the Quuppa tags. Quuppa currently does offer a first party tool for data collection and visualization, but it's limited in functionality, very difficult to tailor specifically to Viasat's needs, and only exists as a desktop application. Our web application solution would not only allow for customizability of data visualization, but it would also allow for easy access from the web. The team's goal is to create a functional web application using Quuppa data collected from a mock manufacturing process in the PolyGAIT lab.

The first step was to acquire the Quuppa system and install it in the PolyGAIT lab. Figure 9 and Figure 10 below show the installation of the Quuppa locators on the ceiling and the Quuppa server in the server rack.



Figure 9: Quuppa Locator installed in PolyGAIT ceiling



Figure 10: QPE server and PoE switch installed in server rack



Once successfully installed, the team came up with an initial flowchart (Figure 11) for what visuals, metrics, and functionalities would be most helpful on the web app. This was then run by a variety of Viasat’s stakeholders for feedback. A second and final flowchart was then created that implemented the feedback we received. In the new flowchart, the web app view is divided into separate tabs for different stakeholder groups. With this organization, the visuals and KPIs displayed on the web app are based on what is most relevant to the respective stakeholders. We included separate tabs for the mainline, clinic/rework, managers, executives, and industrial engineers/continuous improvement stakeholders. In addition, we added a tag assignment tab for when a product leaves the facility, and the tag is moved to another piece of work in process.

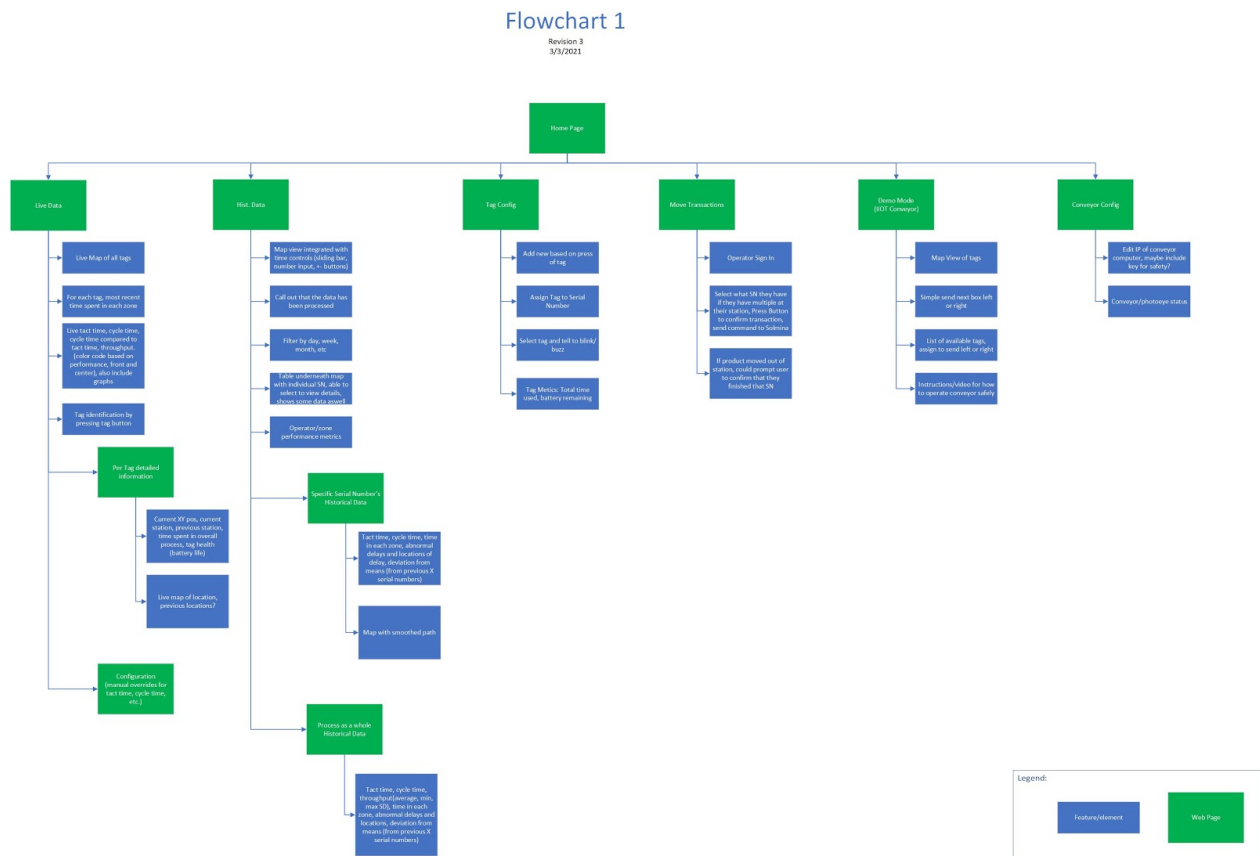

Figure 11: Web App Requirements Flowchart 1

Due to the highly technical nature of this project, expert opinions from Cal Poly computer science students were necessary in order to make informed solution direction decisions. Most of the work lied in creating appropriate data smoothing and path snapping algorithms to stabilize the incoming data from the Quuppa system, as well as designing a database to store the historical data for easy retrieval and analysis. The computer science students helped our team ideate different solution directions that use the Quuppa system - for

example, different database schemas, data transport protocols, data smoothing methods, and visualization tools - that are beyond the knowledge scope of the industrial engineering students on this team.

With the addition of our new computer science team members, we considered the structure for the data flow in our solution. We decided to first gather the real-time location and time data from the Quuppa UDP stream, send the data through custom filtering algorithms, and then store it in the database which feeds the web app. We decided to use PostgreSQL for the database because it works well with JSON data, which is what the Quuppa UDP stream provides. We created three tables in the database: a table to store incoming location data samples, a table to store units sent to the clinic, and a table to match tag IDs with tag names and WIP serial numbers. We also decided to use Django as the backend framework for our web app because it is inherently data-driven, which made it an excellent choice for an app meant to convey information from data. We chose Bootstrap for our frontend framework due to several of the team members having prior experience with it, as well as its de facto status as one of the most popular frontend frameworks at the time of this writing. Future areas of expansion for this system include an Industrial Internet of Things (IIoT) integration with the conveyor in the PolyGAIT lab, as well as further research into integrating Quuppa with Solumina at Viasat. Figure 12 below displays an organized flowchart of the data flow in our system.

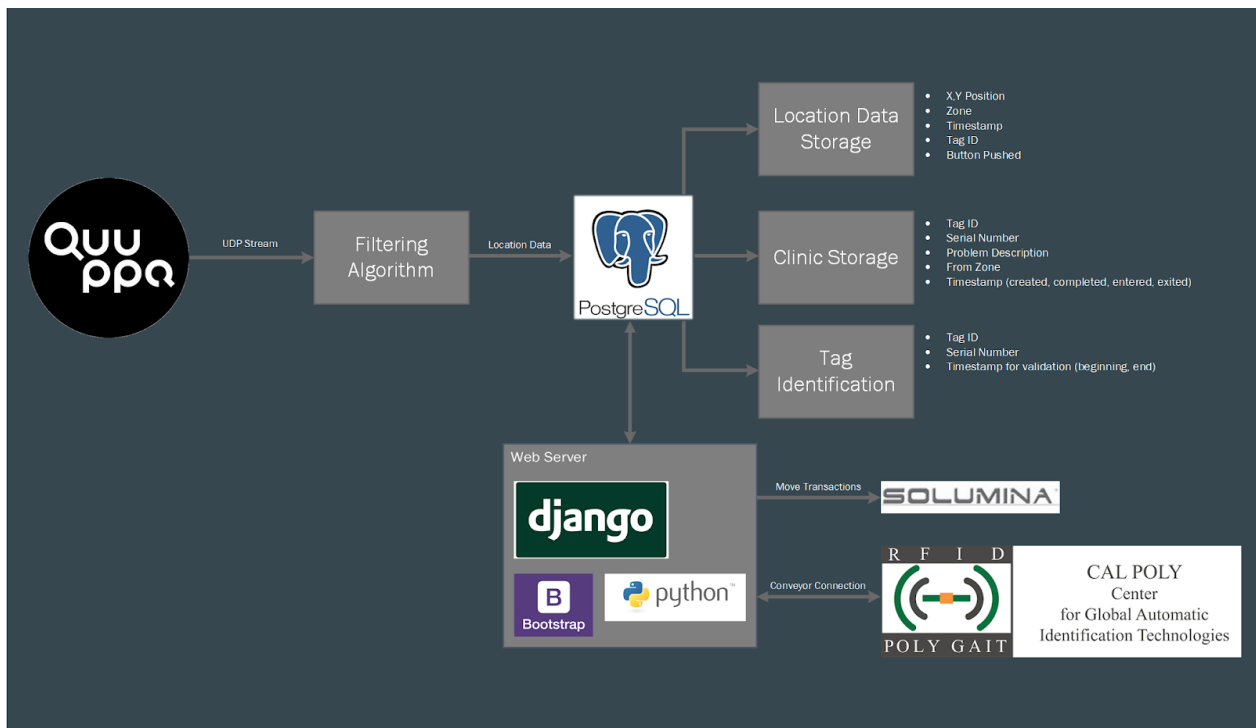

Figure 12: Web App Architecture

Once we established data flow from the Quuppa UDP stream, through the filtering algorithm, and into Postgres, we developed the frontend using a combination of Bootstrap, HTML, and JavaScript. We built the backends for the different tabs using Django views written in Python. With the front and back ends established, we were able to begin validating the web app.

In order to accurately validate the solutions we generated, we created a mock manufacturing process that mimics Viasat's current process. As a team, we were faced with the decision to either create a process as similar as possible to the one occurring at the Viasat facility, or to create an arbitrary, and much simpler, mock process. Because the objectives of the project are predominantly focused on improving location tracking accuracy and display, irrespective of the actual work being done, we decided to pursue the arbitrary and simpler process. We are interested in the movement of the product through the system, so the actual work being done in the process steps themselves isn't important. This decision allowed us to dedicate more of our efforts towards achieving the project objectives.

The mock process we designed consists of plastic totes with lids that represent work in process (displayed below in Figure 13). The totes enter the conveyor system and move to Workstations 1A and 1B. Here, each line worker removes the lid from the tote, flips the lid around, and puts it back on (simulating the time taken to perform meaningful work on a WIP item at Viasat). After this action is completed, the tote is then added back to the conveyor system and moves on to Workstation 2. At Workstation 2, line workers inspect the totes to ensure the quality of the lid placement from Workstation 1. All nonconforming lid placements are moved from Workstation 2 to the Rework table (also known as the Clinic in Viasat's terminology), where the lid orientation is fixed, and the tote is returned to the system. Then, the totes move onto the shipping area. On Viasat's production line, the items would then be shipped out, but in our mock process, the totes are simply recycled back to the beginning of the manufacturing process. This process was repeated as a means of generating data to be used in developing and validating the dashboard and database system.



Figure 13: Mock Manufacturing Process Tote



The process took place in the PolyGAIT lab on the Cal Poly campus. The lab has a conveyor belt system that was used to execute the process. The image below, generated with Vectorworks, displays the floorplan of the PolyGAIT facility. The stations described above are labeled on the floor plan. The flow followed a circular pattern in the direction of the conveyor belt.

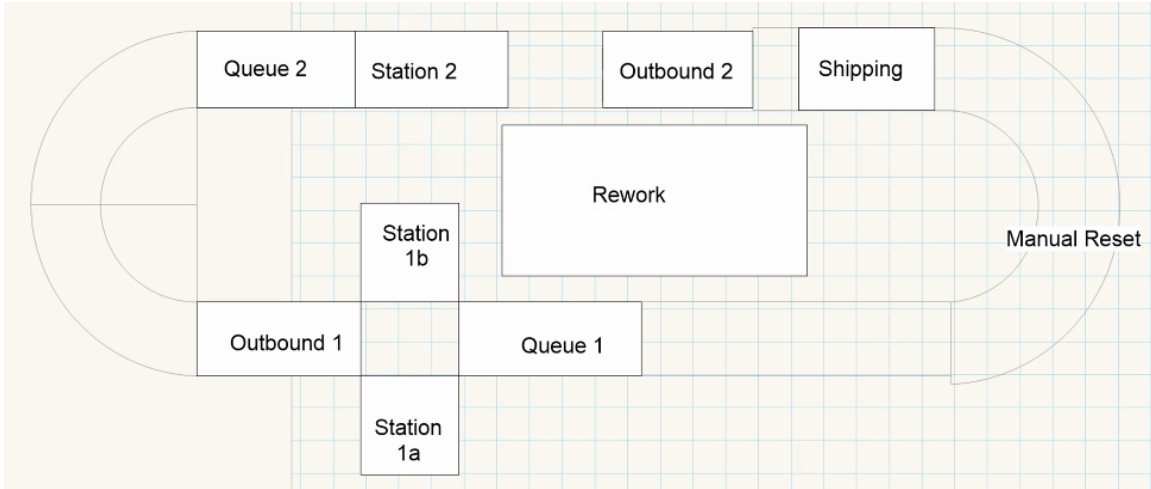

Figure 14: PolyGAIT Conveyor Floor Plan with Labeled Workstations

### Web App Demonstration

The web app solution the team created is currently public with limited functionality due to the timeline of the project. It can be accessed via the Cal Poly VPN (not required if physically on campus) with the following URL: <http://quuppartls.ime.calpoly.edu/>. In order to demonstrate all of the web app's features and functionalities, we will walk through screenshots of all of the pages with descriptions in the pages below.

Figure 15 below is a screenshot of the mainline page of our web app with an overlaid image to show the map's functionality. The navbar at the top of the screen organizes information views tailored to various stakeholder groups. Figure # is intended for the floor workers and the visuals are tailored to the metrics that are most pertinent to these types of employees. There is a live map displaying the location of all tags in the system, a drop down menu to filter a specific workstation, a daily pace gauge (calculated by a running average), a list of all units present in the workstation selected in the dropdown, a button linked to a form in order to send a tag to the clinic (rework station), a running count of the number of units sent to the clinic in the last 8 hours, a yield percentage, and a table to confirm and deny move transactions. The red dots in the map represent the location of the Quuppa tags that the team member is holding in the overlaid image. The map is both accurate and updates quickly in near-real-time (at the time of writing, the map is configured to update every eighth of a second, or 125 ms). The update frequency can be customized as needed through the Django HTML templates.

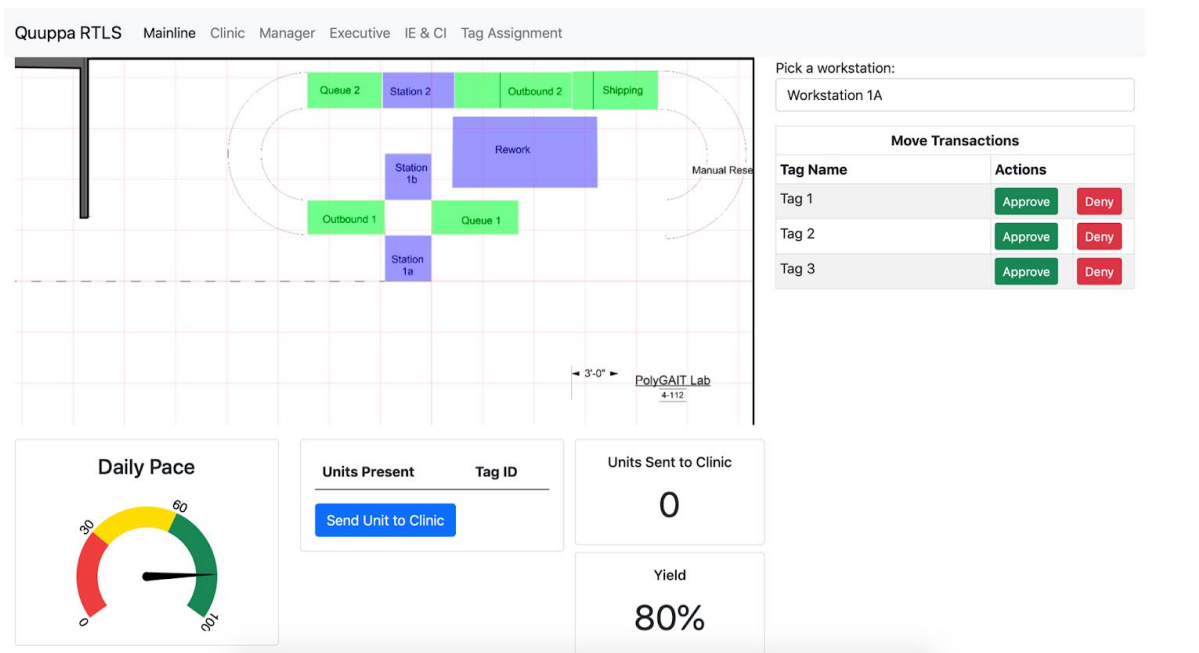

Figure 15: Web App Mainline Page

The subsequent tab in the app is designated for the clinic. In this tab, we have created a table displaying all units present in the clinic along with all of the pertinent information collected from the tags and the clinic form submitted from the mainline tab. This is intended to be an organizational tool for the operators in the clinic. In addition to listing all of the relevant information, there is also an option to remove the entry from the table once the issue with the work in process is resolved.

Quuppa RTLS Mainline Clinic Manager Executive IE & CI Tag Assignment

Nonconforming Material					
Tag ID	Date/Time Entered	Origin Workstation	Nonconforming Description	Date/Time Resolved	Resolved
a4da22e14550	May 20, 2021, 6:37 p.m.	Workstation 1A	dgraewfaeww	None	<a href="#">Resolve</a>
a4da22e14550	May 20, 2021, 6:38 p.m.	Workstation 1A	faewaew	None	<a href="#">Resolve</a>
a4da22e14550	May 20, 2021, 6:39 p.m.	Workstation 1A	asdfsad	None	<a href="#">Resolve</a>
a4da22e147ec	May 21, 2021, 3:34 p.m.	Workstation 1A	dafvads	None	<a href="#">Resolve</a>
a4da22e147cb	May 21, 2021, 3:38 p.m.	Workstation 1A	loose screw	None	<a href="#">Resolve</a>
a4da22e14810	May 21, 2021, 3:51 p.m.	Workstation 1A	loose screw	None	<a href="#">Resolve</a>

Figure 16: Web App Clinic Page

The next page is designated to the managerial stakeholders. This tab features a live map, a Pareto chart of nonconformities encountered on the floor, and status gauges for process time, queue time, and cycle time. Due to time constraints, most of the information needed to calculate these metrics was not available. However, our team has created all of the equations necessary to calculate these metrics, to be implemented by the next senior project team assigned to this project.

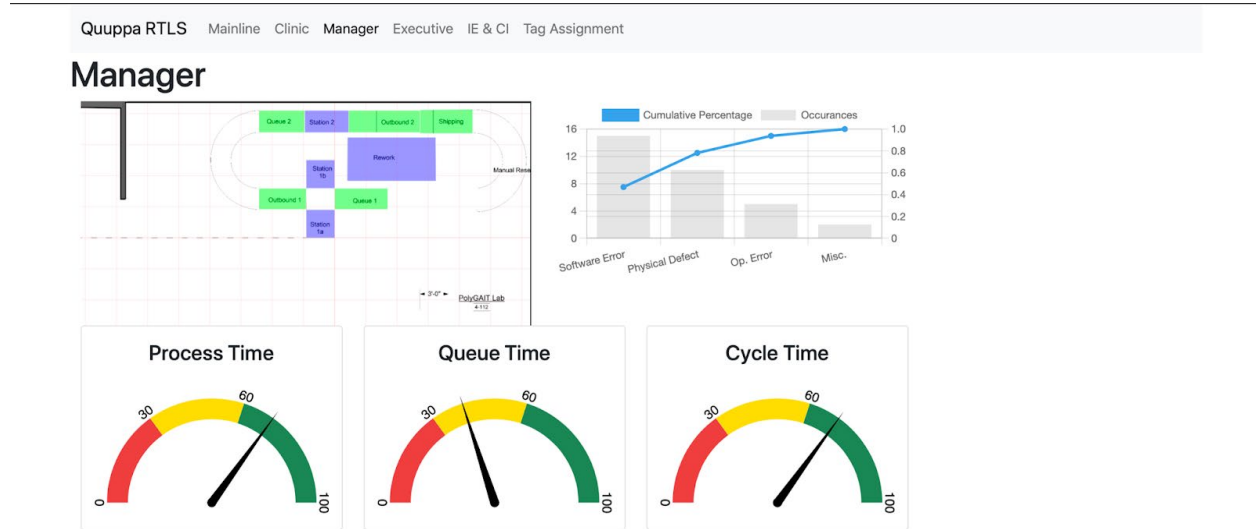

Figure 17: Web App Manager Page

Next is the executive page, which displays metrics representing the bigger picture of the process. The most important aspect of this page is the ability for the user to select a time frame and compare historic data to current data. The user can select a time frame in the dropdown on the right side of the screen and display the visuals that pertain to the historic time period selected. This allows executives to discover trends and better manage their manufacturing lines. Information such as yield and cost overtime, problem frequency, average time spent to solve a problem, percentage of time spent on takt, on time delivery, and lead time by serial number are displayed on this tab.

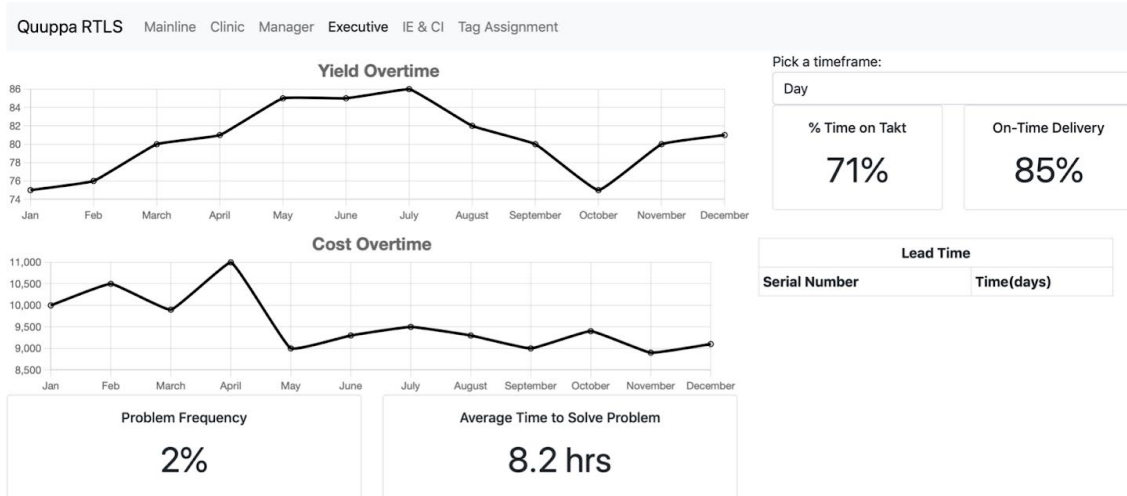

Figure 18: Web App Executive Page

The IE& CI (Industrial Engineering and Continuous Improvement) tab contains visuals most relevant to stakeholders involved in process improvement. This is the only tab available that allows the user to filter the data visualized on the page by workstation and by timeframe. Once the filter is set by the dropdowns at the bottom of the page, the user can access very specific information from the process in order to increase the efficiency of the process. These visuals include a bar graph of bottlenecks witnessed on the line, the amount of value-added vs. non-value-added time spent in the process, and status gauges similar to those in the manager tab. This is the last tab designated to a specific stakeholder group in our web app.

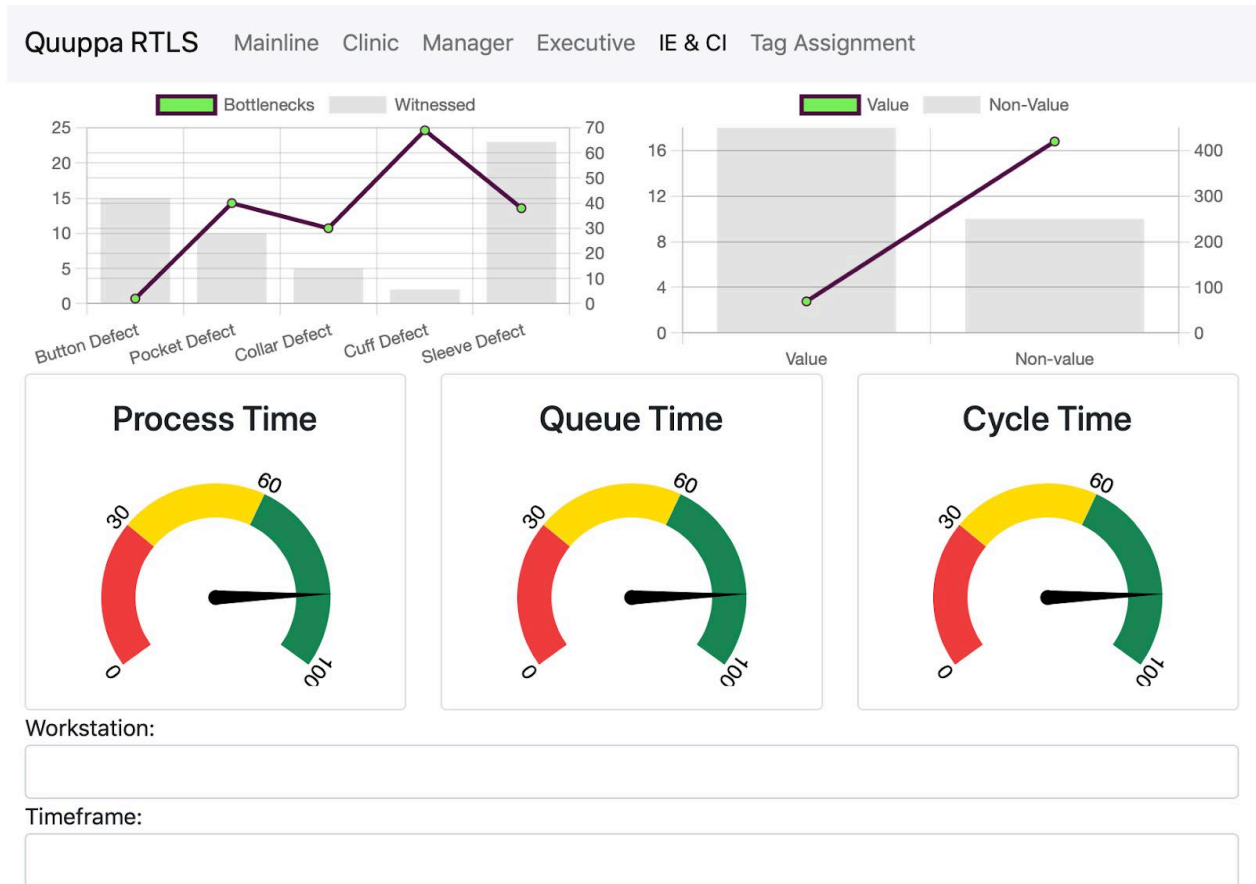

Figure 19: Web App IE/CI Page

Lastly, we included a fundamental feature in our web app, the tag assignment page (Figure 20), that allows for the Quuppa tags to be reassigned. Once the product tied to a tag is ready to be shipped, the tag needs to be removed and stuck to another serial number. This wouldn't be possible unless the tags were able to be reassigned to a new WIP serial number and stored in the database as such. With our tag assignment page, we make this process very intuitive and user friendly, despite the back end involved. This tab allows the user to simply enter the tag ID found on the back of each tag, an arbitrary tag name (assigned by Viasat), and the serial number of the new product the tag will be assigned to. The timestamp marking the effective date and time of the assignment is generated automatically. Once the confirm button is selected, the change is made, and the tag is ready to be deployed with the corresponding WIP serial number. This tab also displays a table of all active tags allowing users to organize active vs. non-active tags and serial numbers.

Quuppa RTLS Mainline Clinic Manager Executive IE & CI Tag Assignment

Tag ID (MAC Address)  
a43b5c3d5d43

Tag Name  
25

Serial Number  
DDMMYYYY 47358 XXXX

Timestamp  
2021-05-17 20:47:00-07

[Confirm Tag Assignment](#)

Tag ID	Tag Name	Serial Number	Remove
1	default name	1234	<a href="#">Remove</a>
a4da22e14511		20052021 12345 ABCD	<a href="#">Remove</a>
a4da22e14550	test	4q3fqew	<a href="#">Remove</a>
6		05172021 12345 test1234	<a href="#">Remove</a>
a4da22e147ec	test	12345	<a href="#">Remove</a>
a4da22e147cb	14	asdfaw23w	<a href="#">Remove</a>

Figure 20: Web App Tag Assignment Page

## V. **Implementation Plan**

At this point in the project, it would not be efficient for Viasat to implement any of the progress we have made. It would be best for the implementation process to start after an additional senior project team tackles some of the issues we did not have time to resolve. However, if Viasat wanted to start early, it could implement the data streaming code we have developed and begin to store the Quuppa data into a database of their own. This would be a great first step and would expedite the ultimate implementation process when the project is completed.



## VI. Next Steps

Currently, the plan is to pass this project on to another senior project for next year. This new senior project team would tackle the scope of taking the current state of the web app and continuing to develop it to a point where it is ready to be implemented at Viasat's San Diego facility. Most of the back- and frontend infrastructure is in place already, and an additional senior project team would be enough to finish the project. Our team will make extensive documentation pages in order to facilitate a smooth transition, and this will ensure the incoming senior project team can minimize their time spent familiarizing themselves with our existing code and maximize their productive development time.

At this point, many of the KPIs on our web app are hard coded and aren't linked to the data in our database. This is because we were unable to set up these calculations and queries with all of the infrastructure and framework required to get the server and database queries running. The next senior project team could use the equations we have derived to calculate additional metrics from the database data, and implement those calculations to be displayed in the app.

In addition, due to lack of available documentation regarding Solumina's Application Programming Interface (API), we were unable to achieve one of Viasat's goals of integrating the web app with Solumina in order to confirm move transactions. This would require specialization in Solumina and was not feasible for our senior project scope. The information and API documentation available online is almost nonexistent, and generating a viable integration with an unfamiliar software system with almost no available documentation was simply not possible given the time frame of our project. The next team could manage this task with help from the Solumina specialists at Viasat.

Lastly, future steps would be integrating the web app with the PolyGAIT conveyor system. Although it would not be a directly useful feature for Viasat, it would provide great experience for the team, and it is an initiative the PolyGAIT lab has had for some time.

## VII. **Conclusions and Recommendations**

As we wrap up our project, we have completed a fully functional backend system for organizing and maintaining information about the various tags within the system, as well as smoothing algorithms in order to make sure that our data is more precise and trustworthy. We have also developed an interactive web app in order to view the collected data in a user-friendly manner, as well as easily filter and visualize tag information based on various queries such as timelines and specific workstations. Although all of the foundational infrastructure has been developed, the project is not yet fully completed and will be passed on to a future senior team to achieve the sponsor's remaining goals and implement the final deliverable at Viasat's facility.

In summary, the project is ready for a smooth hand-off to a senior project team for next year. Our team is very proud of the progress we have made, and we cannot wait to see this project be completed and implemented into Viasat's facility.

## REFERENCES

- Alarafi, A., Al-Salman, A., Alsaleh, M., Alnafessah, A., Al-Hadhrami, S., Al-Ammar, M. A., & Al-Khalifa, H. S. (2016). Ultra Wideband Indoor Positioning Technologies: Analysis and Recent Advances. *Sensors (Basel)*, *16*(5). doi:10.3390/s16050707
- Ala-Risku, T., Collin, J., Holström, J., & Vuorinen, J.-P. (2010). Site inventory tracking in the project supply chain: problem description and solution proposal in a very large telecom project. *Supply Chain Management: An International Journal*, *15*(3). Retrieved October 25, 2020, from <https://www-emerald-com.ezproxy.lib.calpoly.edu/insight/content/doi/10.1108/13598541011040008/full/html>
- Bar Code Direct. (2015, September 5). *The Evolution of Inventory Management*. Retrieved November 1, 2020, from Bar Code Direct: <https://www.barcodedirect.com/the-evolution-of-inventory-management/>
- Barcoding. (n.d.). *The History of Barcodes*. Retrieved November 1, 2020, from Barcoding: <https://www.barcoding.com/resources/barcoding-basics/the-history-of-barcodes/>
- Basalamah, A. (2016). Sensing the Crowds Using Bluetooth Low Energy Tags. *IEEE Access*, *4*, 4225-4233. doi:10.1109/ACCESS.2016.2594210
- Chila, M., & Susi, L. C. (2019). Implementing a Web-Based Inventory Tracking System: A Quality Improvement Initiative. *Journal of Radiology Nursing*, *38*(4). Retrieved October 25, 2020, from <https://www-sciencedirect-com.ezproxy.lib.calpoly.edu/science/article/pii/S1546084319301725?via%3Dihub>
- Cruz, F. (2001). *Herman Hollerith*. Retrieved November 1, 2020, from Columbia University Computing History: <http://www.columbia.edu/cu/computinghistory/hollerith.html>
- Faragher, R., & Harle, R. (2015). Location Fingerprinting With Bluetooth Low Energy Beacons. *IEEE Journal on Selected Areas in Communications*, *33*(11), 2418-2428. Retrieved October 25, 2020, from <https://ieeexplore-ieee-org.ezproxy.lib.calpoly.edu/document/7103024>
- History of Inventory Management Technology*. (2018, June 16). Retrieved November 1, 2020, from City Clean and Simple: <https://www.citycleanandsimple.com/2018/07/16/history-of-inventory-management-technology/>
- Hsu, V., Lee, C., & So, K. C. (2006). Optimal component stocking policy for assemble-to-order systems with lead-time-dependent component and product pricing. *Management Science*, *52*(3). Retrieved November 1, 2020, from [https://go-gale-com.ezproxy.lib.calpoly.edu/ps/i.do?p=AONE&u=calpolyw\\_csu&id=GALE|A144388274&v=2.1&it=r](https://go-gale-com.ezproxy.lib.calpoly.edu/ps/i.do?p=AONE&u=calpolyw_csu&id=GALE|A144388274&v=2.1&it=r)

- Huang, G. Q., Zhang, Y. F., & Jiang, P. Y. (2008). RFID-based wireless manufacturing for real-time management of job shop WIP inventories. *The International Journal of Advanced Manufacturing Technology*, 36(7-8), 752-764. Retrieved November 1, 2020, from [https://search-proquest-com.ezproxy.lib.calpoly.edu/docview/2262435348?rfr\\_id=info%3Axri%2Fsid%3Aprimo](https://search-proquest-com.ezproxy.lib.calpoly.edu/docview/2262435348?rfr_id=info%3Axri%2Fsid%3Aprimo)
- IoT Based Food Inventory Tracking System*. (2019). Singapore: Springer Singapore. Retrieved October 25, 2020, from [https://link-springer-com.ezproxy.lib.calpoly.edu/chapter/10.1007%2F978-981-13-5758-9\\_4](https://link-springer-com.ezproxy.lib.calpoly.edu/chapter/10.1007%2F978-981-13-5758-9_4)
- Leung, J. (2016, June 25). *Inventory Tracking Software Improvement Project*. Retrieved October 25, 2020, from Digital Commons @ Cal Poly: <https://digitalcommons.calpoly.edu/cgi/viewcontent.cgi?article=1214&context=imesp>
- Pancham, J., Millham, R., & Fong, S. J. (2020). Analysis of Bluetooth Low Energy RSSI Values for Use as a Real Time Link Quality Indicator for Indoor Location. In *Computational Science and its Applications - ICCSA 2020* (pp. 980-991). Springer, Cham. Retrieved November 2, 2020, from [https://link-springer-com.ezproxy.lib.calpoly.edu/chapter/10.1007/978-3-030-58817-5\\_69](https://link-springer-com.ezproxy.lib.calpoly.edu/chapter/10.1007/978-3-030-58817-5_69)
- Quick, Accurate Inventory Tracking. (2001). *Modern Materials Handling*, 56(9), 89. Retrieved November 1, 2020, from [https://go-gale-com.ezproxy.lib.calpoly.edu/ps/i.do?p=AONE&u=calpolyw\\_csu&id=GALE%7CA78178225&v=2.1&it=r](https://go-gale-com.ezproxy.lib.calpoly.edu/ps/i.do?p=AONE&u=calpolyw_csu&id=GALE%7CA78178225&v=2.1&it=r)
- Ramakirshnan, R., Gaur, L., & Singh, G. (2016). Feasibility and Efficacy of BLE Beacon IoT Devices in Inventory Management at the Shop Floor. *International Journal of Electrical and Computer Engineering*, 6(5). Retrieved October 25, 2020, from [https://search-proquest-com.ezproxy.lib.calpoly.edu/docview/1867955823?rfr\\_id=info%3Axri%2Fsid%3Aprimo](https://search-proquest-com.ezproxy.lib.calpoly.edu/docview/1867955823?rfr_id=info%3Axri%2Fsid%3Aprimo)
- Roberti, M. (2005, January 16). *The History of RFID Technology*. Retrieved November 1, 2020, from RFID Journal: <https://www.rfidjournal.com/the-history-of-rfid-technology>
- Rodgers, M. (1996). Taking stock: keeping food costs in line starts with accurate inventory tracking. Software specifically for restaurant use takes the pain from the process. *Restaurants and Institutions*, 106(15). Retrieved November 1, 2020, from [https://go-gale-com.ezproxy.lib.calpoly.edu/ps/i.do?p=AONE&u=calpolyw\\_csu&id=GALE|A18426370&v=2.1&it=r](https://go-gale-com.ezproxy.lib.calpoly.edu/ps/i.do?p=AONE&u=calpolyw_csu&id=GALE|A18426370&v=2.1&it=r)
- Shovic, J. C. (2016). *Raspberry Pi IoT Projects: Prototyping Experiments for Makers*. Berkeley, California: Apress L. P. Retrieved October 25, 2020, from <https://link-springer-com.ezproxy.lib.calpoly.edu/book/10.1007%2F978-1-4842-1377-3>

- Subhan, F., & Hasbullah, H. B. (2010). Minimizing discovery time in bluetooth networks using localization techniques. *2010 International Symposium on Information Technology* (pp. 648-653). Kuala Lumpur, Malaysia: IEEE. doi:10.1109/ITSIM.2010.5561532
- Vaupel, T., Seitz, J., Kiefer, F., Haimerl, S., & Thielecke, J. (2010). Wi-Fi positioning: System considerations and device calibration. *2010 International Conference on Indoor Positioning and Indoor Navigation*. doi:10.1109/IPIN.2010.5646207
- Want, R. (2006). An introduction to RFID technology. *IEEE Pervasive Computing*, 5(1), 25-33. doi:10.1109/MPRV.2006.2
- What is RFID?* (2020, April 14). Retrieved November 1, 2020, from All About Electronics: <https://passive-components.eu/what-is-rfid-how-rfid-works-rfid-explained-in-detail/>