

THE CAR (CONFRONT, ADDRESS, REPLACE) STRATEGY: AN
ANTIRACIST ENGINEERING PEDAGOGY

A Thesis

presented to

the Faculty of California Polytechnic State University

San Luis Obispo

In Partial Fulfillment

of the Requirements for the Degree

Master of Science in Electrical Engineering

by

Amman Fasil Asfaw

June 2021

© 2021

Amman Fasil Asfaw

American Society for Engineering Education

ALL RIGHTS RESERVED

TITLE: The CAR (Confront, Address, Replace)
Strategy: An Antiracist Engineering Pedagogy

AUTHOR: Amman Fasil Asfaw

DATE SUBMITTED: June 2021

COMMITTEE CHAIR: Andrew R. Danowitz, Ph.D.
Electrical Engineering - Cal Poly

COMMITTEE MEMBER: Jane L. Lehr, Ph.D.
Ethnic Studies; Women's, Gender and
Queer Studies - Cal Poly

COMMITTEE MEMBER: Michael D. Whitt, Ph.D.
Biomedical Engineering - Cal Poly

COMMITTEE MEMBER: David B. Braun, Ph.D.
Electrical Engineering - Cal Poly

COMMITTEE MEMBER: Abdimalik Buul, Ed.D.
Counseling and School Psychology - San
Diego State University

CONTENT WARNING

The content of this thesis discusses potentially triggering engineering terminologies, includes culturally insensitive engineering diagrams, and alludes to traumatic world history. Some may find the subject of this multidisciplinary thesis emotionally challenging or intellectually uncomfortable to digest. Please find time to take care of yourself before and after reading this thesis.

Abstract

The CAR (confront, address, replace) Strategy is an antiracist pedagogy aiming to drive out exclusionary terminology in engineering education.

“Master-slave” terminology is still commonplace in engineering education and industry. However, questions have been raised about negative impacts of such language. Usage of iniquitous terminology such as “master-slave” in academia can make students—especially those who identify as women and/or Black/African-American—feel uncomfortable, potentially evoking Stereotype Threat and/or Curriculum Trauma [1], [2]. Indeed, prior research shows that students from a number of backgrounds find non-inclusive terminologies such as “master-slave” to be a major problem [1]. Currently, women-identifying and gender nonbinary students are underrepresented in the engineering industry while Black/African-American students are underrepresented in the entire higher education system, including engineering fields [3], [4].

The CAR Strategy, introduced here, stands for: 1) confront; 2) address; 3) replace and aims to provide a framework for driving out exclusionary terminologies in engineering education such as “master-slave.” The first step is to confront the historical significance of “master-slave” terminology. The second step is to address the technical inaccuracies of “master-slave”. Lastly, replace “master-slave” with an optional but recommended replacement terminology.

This thesis reports on student perceptions and the effectiveness of The CAR Strategy piloted as a teaching framework in the computer engineering department of Cal Poly. Of 64 students surveyed: 70% either agree or strongly agree that The CAR Strategy is an effective framework for driving out iniquitous terminologies.

Certain portions of this thesis were first presented by Amman Fasil Asfaw at the virtual 2021 American Society for Engineering Education (ASEE) Annual Conference and Exposition. The original publication's copyright is held by ASEE; secondary authors included Storm Randolph, Victoria Siaumau, Yumi Aguilar, Emily Flores, Dr. Jane Lehr, and Dr. Andrew Danowitz [5].

Acknowledgments

Andrew Brown Jr., Duante Wright, Marvin Scott III, Patrick Warren Sr., Vincent Belmonte, Angelo Quinto, Andre Hill, Casey Goodson Jr., Angelo Crooms, Sincere Pierce, Marcellis Stinnette, Jonathan Price, Dijon Kizzee, Rayshard Brooks, Carlos Carson, Tony McDade, George Floyd, Sean Reed, Michael Ramos, Daniel Prude, Breonna Taylor, Mannie Ellis, William Green, John Neville, Elijah McClain, Atatiana Jefferson, Javier Ambler, Sterling Higgins, EJ Bradford Jr., Chop Roundtree Jr., Chinedu Okobi, Botham Jean, Antwon Rose Jr., Saheed Vassell, Stephon Clark, Bijan Ghaisar, Aaron Bailey, Charleena Lyles, Fetus of Charleena Lyles, Jordan Edwards, Chad Robertson, Deborah Danner, Alfred Olango, Terrence Sterling, Korryn Gaines, Joseph Mann, Philando Castile, Alton Sterling, Betty Boo Jones, Quintonio LeGrier, Corey Jones, Jamar Clark, Bam Bam McDole, India Kager, Samuel DuBose, Sandra Bland, Brendon Glenn, Freddie Gray Jr., Walter Scott, Eric Harris, Phillip White, Mya Hall, Meagan Hockaday, Tony Robinson Jr., Janisha Fonville, Natasha McKenna, Jerame Reid, Romain Brisbon, Tamir Rice, Akai Gurley, Tanisha Anderson, Dante Parker, Ezell Ford, Mike Brown Jr., John Crawford III, Tyree Woodson, Eric Garner, Dontre Hamilton, Victor White III, Gabriella Nevarez, Yvette Smith, McKenzie Cochran, Jordan Baker, Andy Lopez, Miriam Carey, BJ Williams, Jonathan Ferrell, Carlos Alcis, Larry Jackson Jr., Kyam Livingston, Clinton Allen, KiKi Gray, Kayla Moore, Jamaal Moore Sr., Johnnie Warren, Shelly Frey, Darnisha Harris, Timothy Russell, Malissa Williams, Noel Palanco, Reynaldo Cuevas, Chavis Carter, Alesia Thomas, Shantel Davis, Sharmel Edwards, Tamon Robinson, Ervin Jefferson III, Kendrec McDade, Rekia Boyd, Shereese Francis, Jersey Green, Wendell Allen, Nehemiah Dillard, Dante' Price, Raymond Allen, Manual Loggins Jr., Ramarley Graham, Kenneth Chamberlain Sr., Alonzo Ashley, Derek Williams, Raheim

Brown Jr., Reginald Doucet, Derrick Jones, DJ Henry Jr., Aiyana Stanley-Jones, Steven Washington, Aaron Campbell, and so many more unarmed Black and brown people killed by police, sheriff deputies, and security guards in America [6].

Contents

List of Tables	xi
List of Figures	xii
1 INTRODUCTION	1
1.1 Use of Questionable Terminologies in Engineering	1
1.2 Motivations of this Research	16
2 BACKGROUND	19
2.1 Curriculum Trauma	19
2.2 Effects of Uncomfortable Engineering Jargon on Inclusivity	21
3 CASE STUDY: THE C.A.R. (CONFRONT, ADDRESS, REPLACE) STRATEGY APPLIED TO “MASTER-SLAVE”	27
3.1 Introduction	27
3.2 Historical Background	31
3.3 The CAR Strategy	33
3.4 Survey Design	34
3.5 Statistical Methods	40
3.6 Quantitative Results	42
3.7 Qualitative Results	53
3.8 Discussion	55
3.9 Remarks	59
4 OPTICAL CHARACTER RECOGNITION (OCR) TEST	60
4.1 Introduction	60
4.2 OCR Tested on ”Master-Slave”	62

4.3	Algorithm Analysis	68
4.4	Efficacy of OCR	70
5	CONCLUSION	72
5.1	Final Presumptions	72
5.2	Recommendations	72
6	APPENDIX	74
6.1	Additional Pre-CAR vs. Post-CAR Alluvial Diagrams	75
6.2	Custom Line Separation Function	77
6.3	Custom Character Separation Function	79
6.4	Custom OCR Code	80
	Bibliography	82

List of Tables

3.1	Questions asked to all respondents in the beginning of the pre-CAR and post-CAR surveys.	35
3.2	Questions asked of respondents if they answer “Strongly agree”, “Agree”, “Neutral”, or “Prefer not to answer” to whether “master-slave” terminology makes them feel uncomfortable.	36
3.3	Pre-CAR and post-CAR questions asked of respondents if they answer “Strongly Disagree” or “Disagree” to whether “master-slave” terminology makes them feel uncomfortable.	37
3.4	Questions asked to all respondents in both the pre-CAR and post-CAR surveys.	38
3.5	Questions asked to all respondents in only the post-CAR survey.	39
3.6	Pre-CAR and post-CAR demographics questions for all respondents. These questions were asked at the end of the survey to avoid introducing Stereotype Threat.	40
3.7	Statistical results of the paired-sample hypothesis tests conducted in Minitab. Asterisks denote the alternative hypothesis was accepted for that question’s hypothesis test. The precision of the p-value was set to the thousandths place.	49

List of Figures

1.1	An example of “master-slave” in computer engineering. A serial peripheral interface (SPI) bus with a master and three slaves daisy chained together [7].	3
1.2	An example of “master-slave” in mechanical engineering. A typical brake/clutch system with master and slave cylinders in a gasoline-powered, manual transmission car [8].	4
1.3	An example of “master-slave” in electrical engineering. A Texas Instruments LM4308 datasheet which contains several instances (highlighted) of ”master” and ”slave” [9].	5
1.4	An example of “master-slave” in computer science. GitHub repositories in 2020 organized by ”master” branches.	6
1.5	An example of “master-slave” in software engineering. An Apple macOS error report on a personal computer in 2020 showing an ”IOSlaveProcessor”.	7
1.6	An example of “master-slave” in aerospace engineering. A United States Navy fighter jet radar with its missile system in ”SLAVE” mode while tracking an unidentified flying object in 2004 (top right) [10].	8
1.7	An example of “master-slave” in architectural engineering design. A traditional floor layout for the ”master” suite in a residential home [11].	9
1.8	An example of “female-male” in electrical engineering. Amazon advertising and selling a ”high-speed HDMI extension cable (male to female)” [12].	10
1.9	An example of “female-male” in electrical engineering. Northern Arizona Wind & Sun’s solar panel instruction manual illustrating how the male connector ”will snap directly into” the female connector [13].	11

1.10	An example of “female-male” in computer engineering. A Malaysian connector supplier labels the female and male headers of a Universal Serial Bus (USB) cable [14].	12
1.11	An example of “female-male” in audio engineering. A United States Army standard audio connectors depicting female and male ”receptacles” and their ”mating cable parts” [15].	13
1.12	An example of “blacklist-whitelist” in computer science. New York-based Consolidated Technologies, Inc. describes blacklisting as ”threat-centric” and whitelisting as ”trust-centric” when summarizing cybersecurity approaches [16].	14
1.13	An example of “black hat - white hat” in computer science. Missouri’s Maryville University asserts the color-based jargon alludes to ”old Western cowboy” hats. Black correlates with ”bad guys” and white correlates with good or ”ethical hackers” [17].	15
2.1	Demographic distribution of gender in the preliminary study (n=77) [1].	22
2.2	Demographic distribution of race in the preliminary study (n=77) [1].	22
2.3	Survey responses when prompted ”I have never considered the impact this terminology may have on others” [1].	23
2.4	Survey responses from the preliminary study when prompted ”The use of this terminology makes me feel uncomfortable” [1].	24
2.5	Survey responses from the preliminary study when prompted ”I would feel empathetic towards a classmate who finds this terminology problematic” [1].	25
2.6	Survey responses from the preliminary study when prompted ”I would accept using an alternate phrase if a classmate expressed discomfort with the use of this terminology” [1].	26
3.1	Visual graphic of The CAR Strategy: 1) confront; 2) address; and 3) replace as applied to ”master-slave” terminology.	29
3.2	Demographic distribution of gender in the pre-CAR, post-CAR, and linked-CAR datasets.	43
3.3	Demographic distribution of race in the pre-CAR, post-CAR, and linked-CAR datasets.	43
3.4	Distribution of responses for questions H1 and H2 from Table 3.5.	45

3.5	Distribution of responses for questions E3, F3, and G3 from Table 3.5.	46
3.6	An example of the Minitab paired-sample hypothesis test's "Individual Value Plot of Differences" for question B3 (n = 56) from Table 3.1.	47
3.7	An example of the Minitab paired-sample hypothesis test's "Individual Value Plot of Differences" for Question F1 (n = 55).	48
3.8	Survey responses for question B3 (n = 56), from Table 3.1, before and after The CAR Strategy.	50
3.9	Survey responses for question C3 (n = 34), from Table 3.2, before and after The CAR Strategy.	51
3.10	Survey responses for question F1 (n = 55), from Table 3.4, before and after The CAR Strategy.	52
3.11	Distribution of responses for question G1, from Table 3.4, in the pre-CAR and post-CAR surveys.	53
4.1	Initial implementation of OCR using MATLAB's built-in <code>ocr()</code> function.	63
4.2	Training alphabet image of Arial font characters for the customized OCR algorithm.	64
4.3	The first line of Fig. 4.2 separated and inverted, using the customized OCR algorithm.	64
4.4	If there is a figure next to the text, the custom line separating code defines the height of the figure as the line height. So according to the custom OCR algorithm, it thinks this binary image is one line of text when it is actually two.	65
4.5	If there is text within a diagram, it cannot be separated and is all counted as one line of text. So according to the custom OCR algorithm, it thinks this image is one line of text when it is actually a complex drawing with many "lines" of independent text.	65
4.6	The custom OCR algorithm also struggles when there are different font sizes on the same line, since one line in a larger font size can be equal to two lines in a smaller font size.	66
4.7	The custom OCR algorithm also struggles when there are different font sizes on the same line, since one line in a larger font size can be equal to two lines in a smaller font size.	66

4.8	A table detailing the area, centroid, and bounding box coordinates for Fig. 4.3. Which is the first line of the Arial test image, Fig. 4.2. The ten rows of the table represent the ten characters in Fig. 4.2.	67
6.1	Survey responses for question B2 (n = 56), from Table 3.1, before and after The CAR Strategy.	75
6.2	Survey responses for question D2 (n = 13), from Table 3.2, before and after The CAR Strategy.	76
6.3	Survey responses for question E1 (n = 56), from Table 3.4, before and after The CAR Strategy.	77

Chapter 1

INTRODUCTION

1.1 Use of Questionable Terminologies in Engineering

Modern-day engineering lexicon is replete with acronyms and jargon which aim to convey the technical topic at hand. Engineering jargon becomes normalized in a systemic fashion. First, potential engineers are typically introduced to already common terminologies as undergraduate students. Engineers in industry standardize these common terminologies through official publications such as datasheets and textbooks. The cycle repeats once the next generation of potential engineers use industrial publications which reinforce legacy terminologies. Academia is influenced by industry to date, yet it also feeds into the industry of the future. Thus, when systemic changes such as accepting new engineering jargon are embarked upon, the responsibility of the endeavor is deflected by both academia and industry. Engineers in academia argue standard engineering terminologies are set by industry. But engineers in industry argue that standard

engineering terminologies were established at the undergraduate level. This systemic pattern may explain how questionable jargon can avoid audit and cement itself in engineering curriculum.

While the vast majority of engineering jargon does not instigate protest, there are select terms which at the very least deserve questioning—if not replacement. Some of these terms include but are not limited to "master-slave", "female-male", "blacklist-whitelist", and "black hat-white hat". These terms deserve questioning or replacement, because without context they seem to allude to traumatic world history, gender roles, and race-based power structures.

"Master-slave" terminology is found in many fields of engineering. In general, "master" and "slave" are used to describe the relationship between two components of an engineering system. For context, Figures [1.1](#), [1.2](#), [1.3](#), [1.4](#), [1.5](#), [1.6](#), and [1.7](#) illustrate several current and recent examples of "master" and/or "slave" in various engineering disciplines. These examples do not represent all instances of the terminology in engineering.

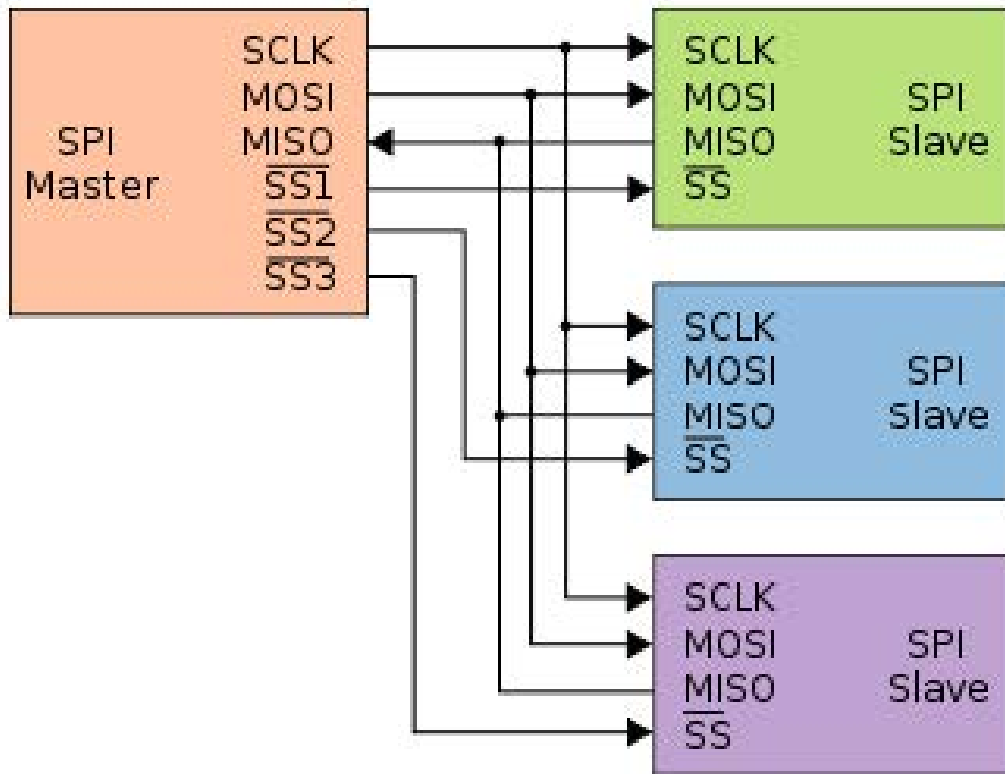

Figure 1.1: An example of “master-slave” in computer engineering. A serial peripheral interface (SPI) bus with a master and three slaves daisy chained together [7].

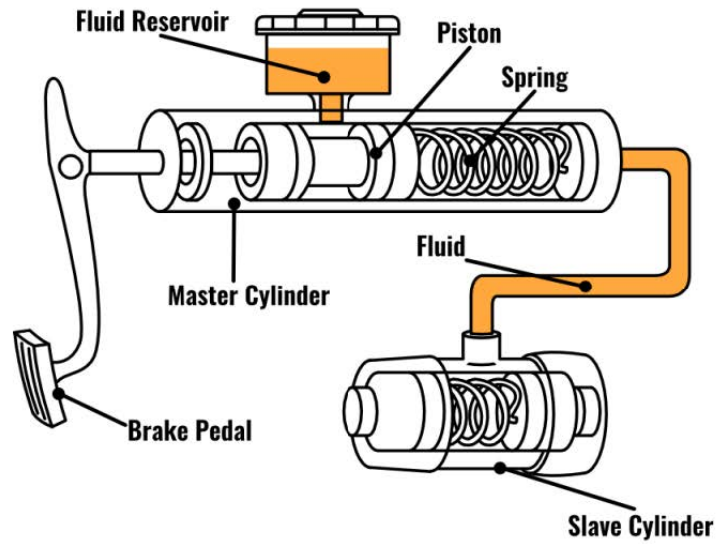

Figure 1.2: An example of “master-slave” in mechanical engineering. A typical brake/clutch system with master and slave cylinders in a gasoline-powered, manual transmission car [8].

LM4308 Mobile Pixel Link Two (MPL-2) – 18-bit CPU Display Interface Master/Slave
 Check for Samples: LM4308

FEATURES

- 18-bit 180 CPU Display Interface
- Supports up to 640 x 480 VGA Formats
- Differential SLVS Interface
- Dual Displays Supported
- WRITE and READ Operations Supported
- Robust Differential Physical Layer
- 400mVpp Differential Signal Swing
- Internal 100 Ω Termination Resistor
- Low Power Consumption
- 5-bit CRC for Data Integrity
- Level Translation between Host and Display
- Low Power Sleep State
- 3.3V Tolerant Master Clock Input Regardless of VDD
- Fast Start Up Time - 1k CLK Cycles
- 1.6V to 2.0V Core / Analog Supply Voltage
- 1.6V to 3.0V I/O Supply Voltage Range

SYSTEM BENEFITS

- Small Interface
- Low Power
- Low EMI
- Intrinsic Level Translation

DESCRIPTION

The LM4308 device adapts a 18-bit CPU style display interfaces to a MPL-2 SLVS differential serial link for displays. Two chip selects support a main and sub display up to and beyond 640 x 480 pixels. A mode pin configures the device as a Master (MST) or Slave (SLV). Both WRITE and READ operations are supported. CPU interface widths below 18-bits are supported by tying unused inputs to a static level.

Differential line drivers and receivers conform to the JEDEC SLVS Standard. When noise is picked up as common mode, it is rejected by the receivers. This is further enhanced with the 50 Ohm output impedance of the driver. The 100 Ohm termination is integrated into the receiver.

Data integrity is insured with a 5-bit CRC field. CRC checking is done for both WRITE and READ operations. An Error (ERR) pin reports the occurrence of an error. A Write Only mode is also provided.

The interconnect is reduced from 23 signals to only 4 active signals with the LM4308 chipset, easing flex interconnect design, size constraints and cost. A low power sleep state entered when the PD* inputs are driven low.

Typical Application Diagram

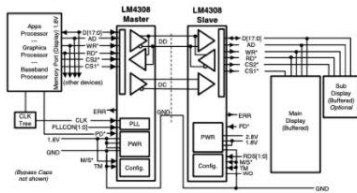

Please be aware that an important notice concerning availability, standard warranty, and use in critical applications of Texas Instruments semiconductor products and disclaimers thereto appears at the end of this data sheet. All trademarks are the property of their respective owners. PRODUCTION DATA: This information is current as of publication date. Products conform to specifications per the terms of the Texas Instruments standard warranty. Production processing does not necessarily include testing of all parameters. Copyright © 2007–2013, Texas Instruments Incorporated

LM4308

SNLS225C – AUGUST 2007 – REVISED MAY 2013

18-bit CPU Display Interface Master/Slave

Examples: LM4308

DESCRIPTION

The LM4308 device adapts a 18-bit CPU style display interfaces to a MPL-2 SLVS differential serial link for displays. Two chip selects support a main and sub display up to and beyond 640 x 480 pixels. A mode pin configures the device as a **Master (MST)** or **Slave (SLV)**. Both WRITE and READ operations are supported. CPU interface widths below 18-bits are supported by tying unused inputs to a static level.

Figure 1.3: An example of “master-slave” in electrical engineering. A Texas Instruments LM4308 datasheet which contains several instances (highlighted) of ”master” and ”slave” [9].

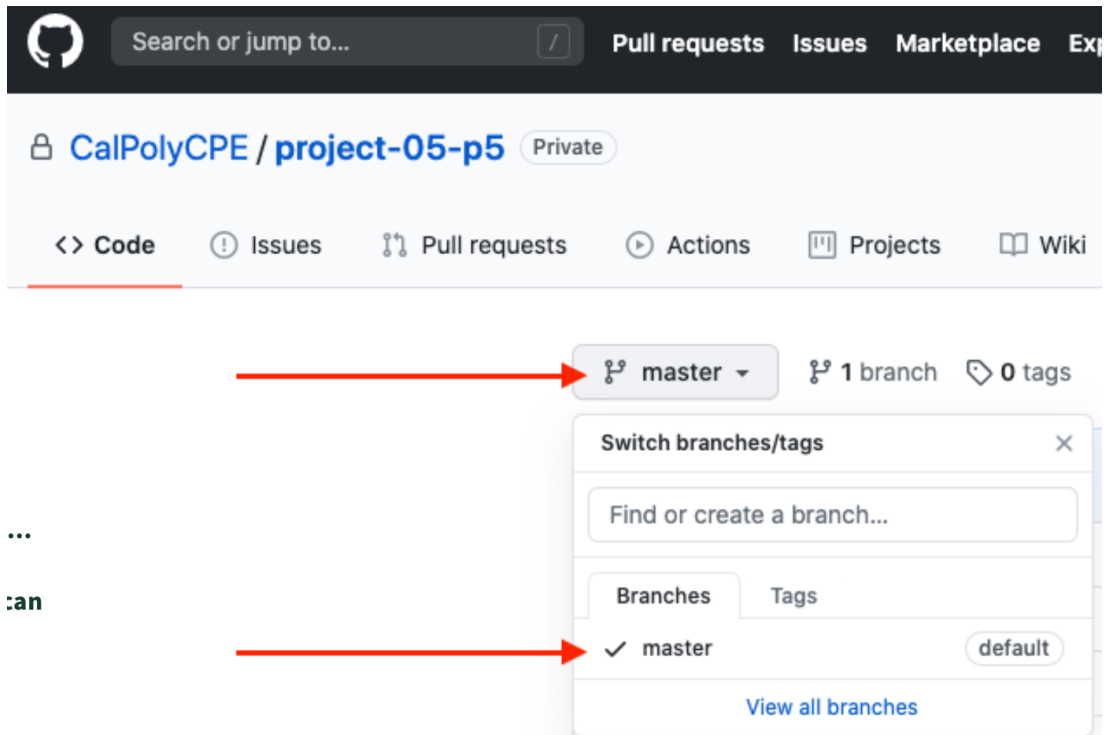

Figure 1.4: An example of “master-slave” in computer science. GitHub repositories in 2020 organized by ”master” branches.

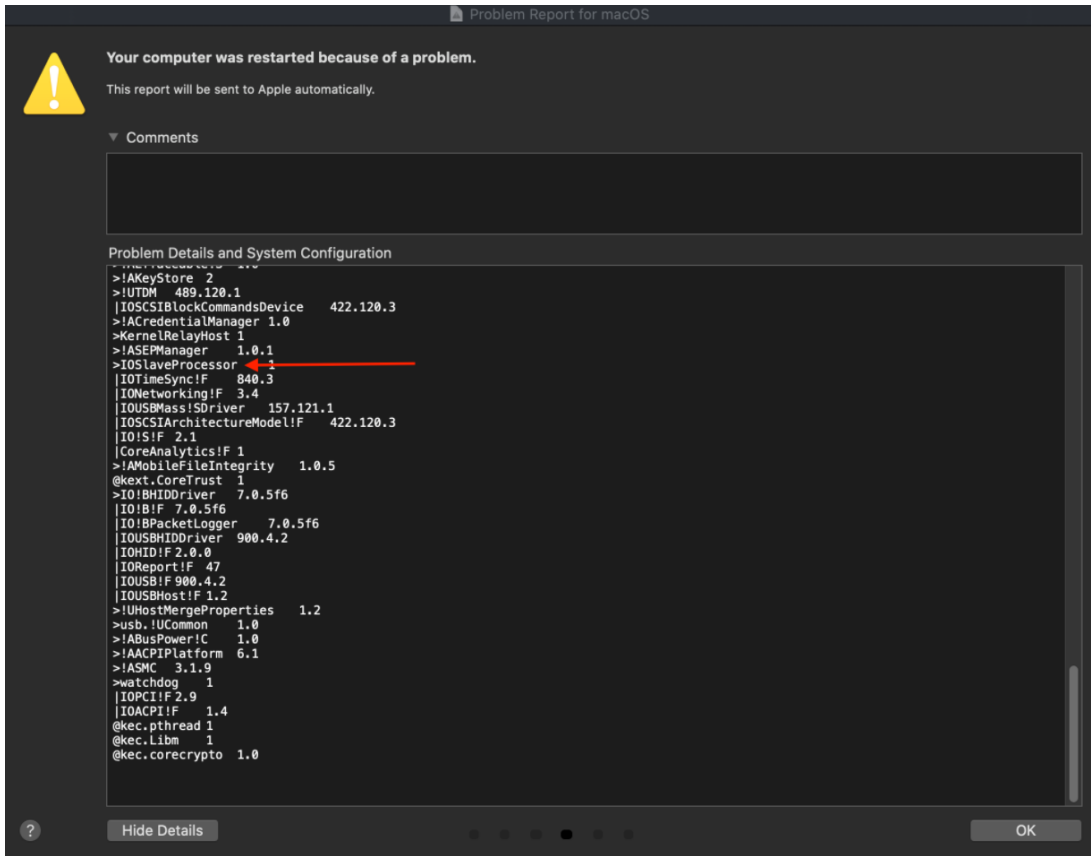

Figure 1.5: An example of “master-slave” in software engineering. An Apple macOS error report on a personal computer in 2020 showing an “IOlaveProcessor”.



Figure 1.6: An example of “master-slave” in aerospace engineering. A United States Navy fighter jet radar with its missile system in “SLAVE” mode while tracking an unidentified flying object in 2004 (top right) [10].

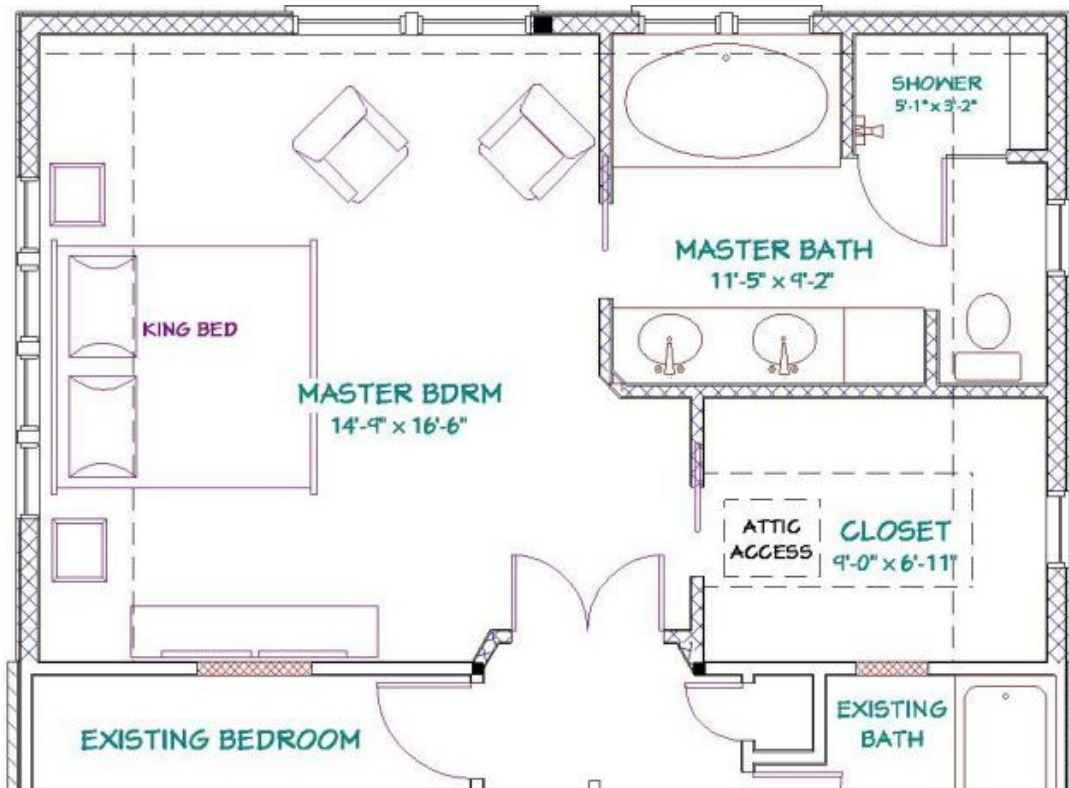

Figure 1.7: An example of “master-slave” in architectural engineering design. A traditional floor layout for the ”master” suite in a residential home [11].

Additionally, Figures 1.8, 1.9, 1.10, and 1.11 show instances of ”female-male” terminology in engineering. An anthropomorphism between engineering connectors and the reproductive organs must be questioned at the very least. Word choice like this begs the questions: does ”female-male” usage in engineering affect how engineers view sexual relationships? Is the normalization of ”female-male” in engineering at all associated with the disproportionate representation of women-identifying and gender nonbinary people in the industry [3]? How should we approach using ”female-male” while teaching engineering to kids who do not yet know what sexual intercourse is?

Anecdotally, I remember the first time I came across "female-male" terminology in engineering. I was about 10 years old and needed to help my mom pick the right HDMI cable online for our new home entertainment system. My neighbor helped us and said we need to purchase a "male to female" HDMI cable (Fig. 1.8). We were both confused. Our neighbor proceeded to awkwardly explain the origins of the technical jargon with his hands. Mind you, at the time my parents had not had "the talk" with me yet (although I knew what sexual intercourse was). It made for a very weird and memorable introduction to the world of tech.



Figure 1.8: An example of "female-male" in electrical engineering. Amazon advertising and selling a "high-speed HDMI extension cable (male to female)" [12].

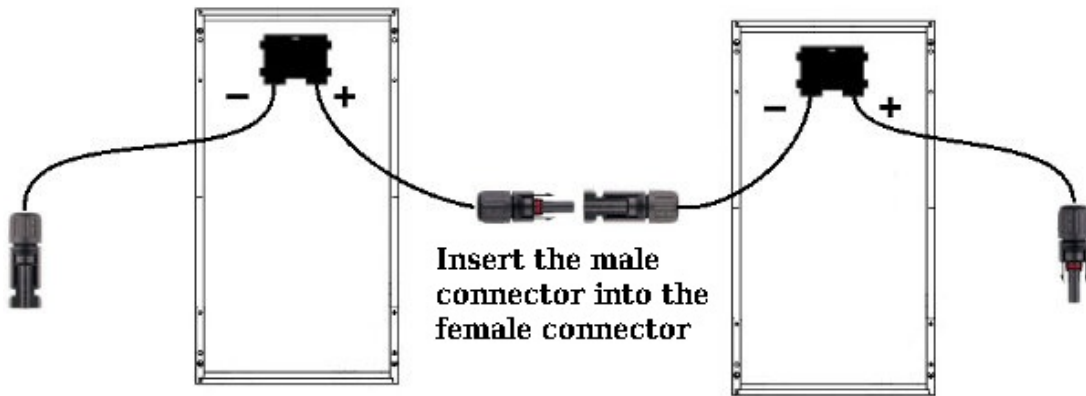

Figure 1.9: An example of “female-male” in electrical engineering. Northern Arizona Wind & Sun’s solar panel instruction manual illustrating how the male connector “will snap directly into” the female connector [13].

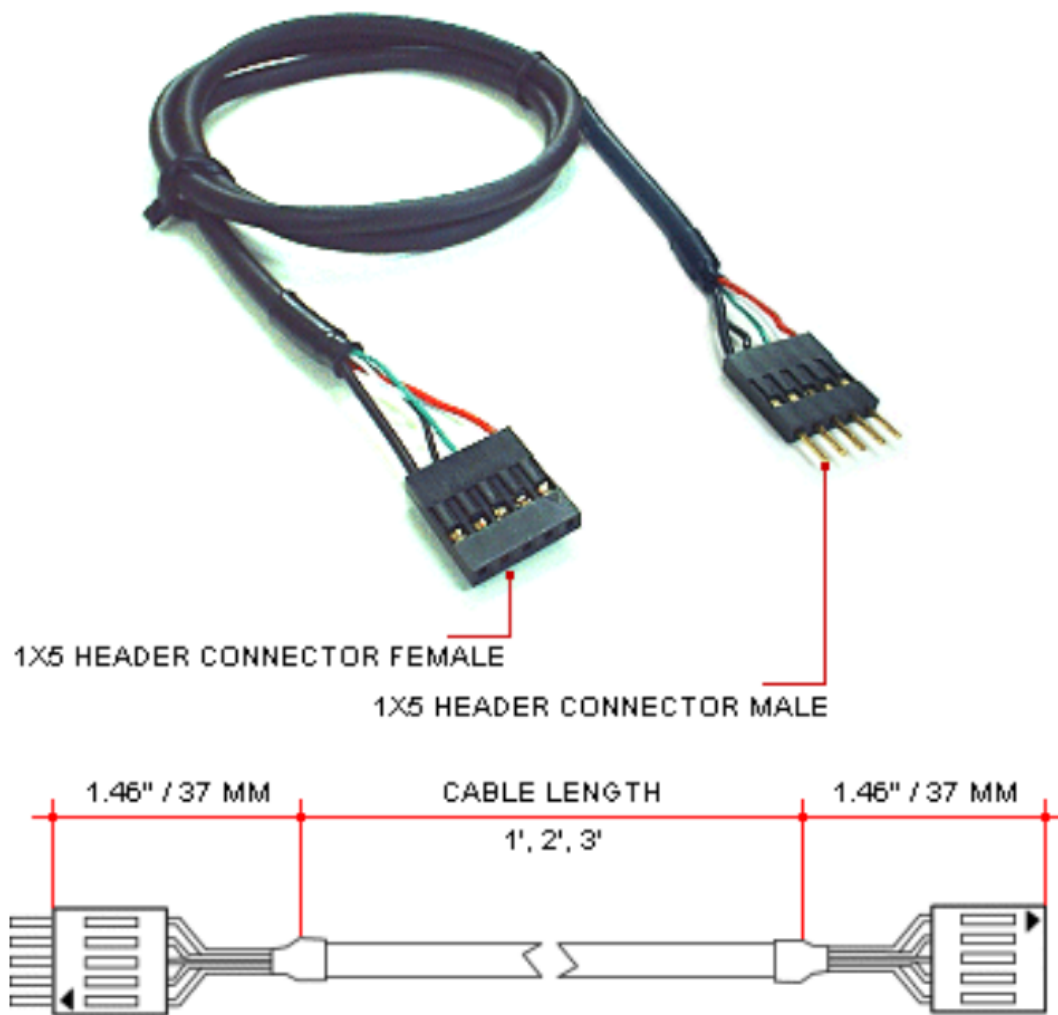

Figure 1.10: An example of “female-male” in computer engineering. A Malaysian connector supplier labels the female and male headers of a Universal Serial Bus (USB) cable [14].

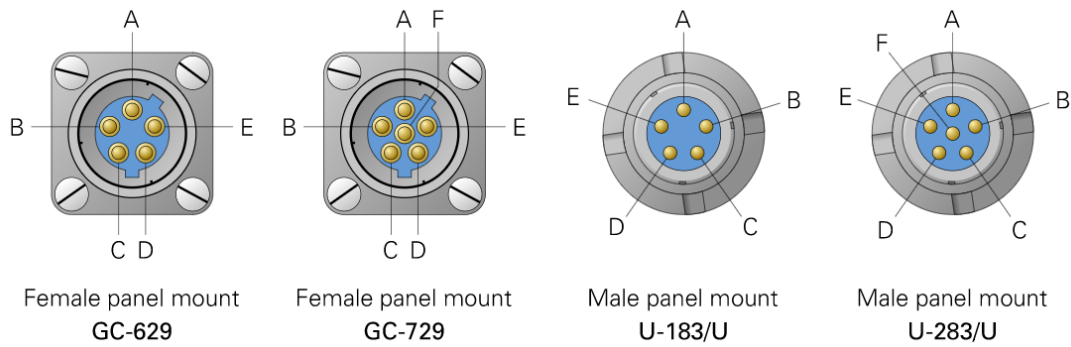

Figure 1.11: An example of “female-male” in audio engineering. A United States Army standard audio connectors depicting female and male ”receptacles” and their ”mating cable parts” [15].

Terms like ”blacklist-whitelist” and ”black hat-white hat” are less common as they are found mainly in the area of cybersecurity within computer science. These two word pairs resort to assigning the colors, black and white, to illegal and legal activities, as shown in Fig. 1.12 and Fig. 1.13.



Figure 1.12: An example of “blacklist-whitelist” in computer science. New York-based Consolidated Technologies, Inc. describes blacklisting as “threat-centric” and whitelisting as “trust-centric” when summarizing cybersecurity approaches [16].

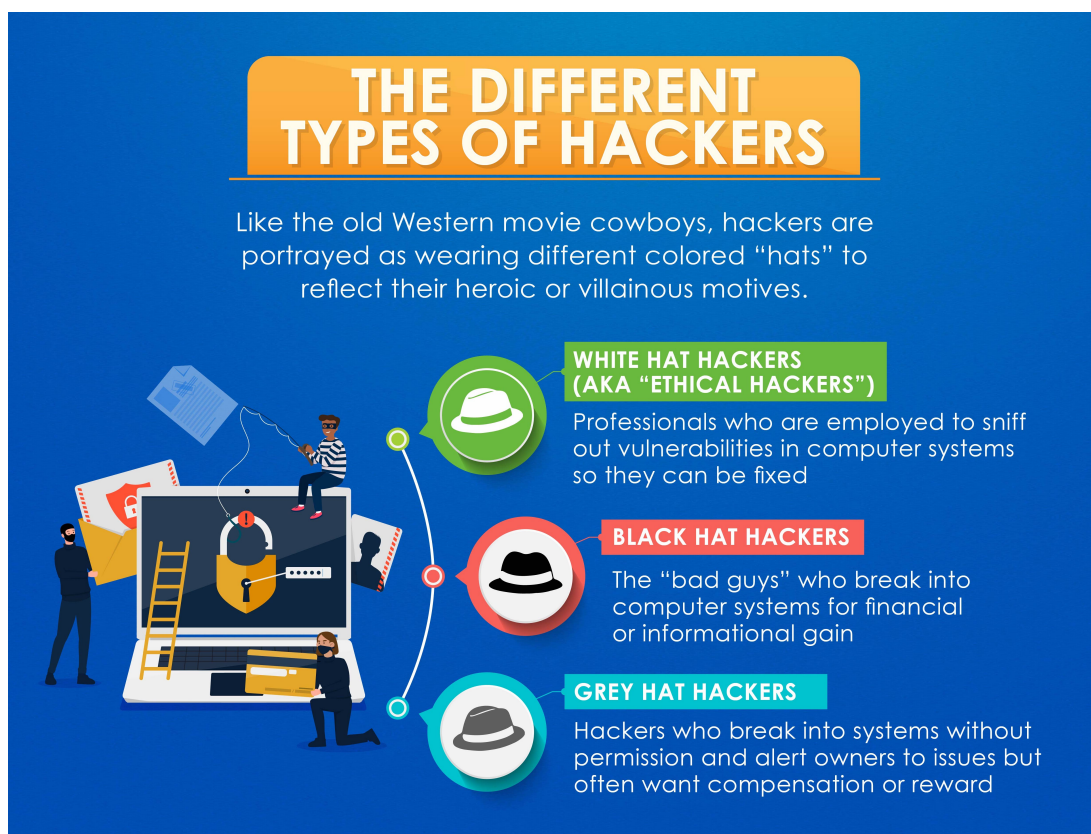

Figure 1.13: An example of “black hat - white hat” in computer science. Missouri’s Maryville University asserts the color-based jargon alludes to ”old Western cowboy” hats. Black correlates with ”bad guys” and white correlates with good or ”ethical hackers” [17].

The examples listed in this thesis section establish a basis and motivation for this research which is detailed in Section 2.2. In Chapter 3 a relevant literature review and preliminary study will be detailed. Then, an in-depth pedagogical case study will be presented. Lastly, a technical solution using Optical Character Recognition (OCR) will propose a way to aid in the replacement of problematic terminology in engineering.

1.2 Motivations of this Research

One motivation for this thesis is based on my empirical analysis of engineering education in America. Although the topic of this thesis is extremely specific and nuanced, it is worthwhile because it attempts to confront, address, and replace potentially triggering terminologies in academia. Less triggering terms in engineering education will lessen the amount of "Curriculum Trauma" experienced by future students [2]. By fostering a more critical and conscious curriculum, progress will be made in shrinking racial and gender-based equity gaps in engineering.

For someone new to engineering, reading and hearing word combinations such as "master-slave", "female-male", "blacklist-whitelist", and "black hat-white hat" may cause confusion because their nontechnical definitions distract from their adopted technical definitions. Further, phrases like these can inherently introduce racial, hierarchical, and prejudicial constructs into the minds of students. Thus, from my perspective as an engineering student, researcher, and educator there are still remnants of patriarchy and white supremacy present in engineering curriculum [18].

An additional and even more specific motivation for this research is "master-slave" terminology is still commonplace in engineering education and industry, however, questions have been raised about negative impacts of such language. The problem is that usage of exclusionary terminology such as "master-slave" in engineering can make students—especially those who identify as women and/or Black/African-American—feel uncomfortable, potentially evoking Stereotype Threat and/or Curriculum Trauma [1].

Right now, there is no automated process which is free and publicly accessible that can detect and replace problematic terminologies on electronic engineering datasheets or diagrams—which is where students may still come across the jargon. Currently, if a user wants to alter their datasheet or diagram, they would have to go through either a costly or a tedious process. The costly option would involve purchasing an AI/OCR-based computer application such as ABBYY FineReader for over 120 U.S. dollars. This potential solution does not align with academia’s spirit of equity, open-inquiry, and democratization.

One could encourage the publisher of the document to change their terminologies. However, such a recommendation would likely take too long for the user, because revisions in publications are a time-consuming process. Also, revisions to datasheets are not traditionally known as a financially profitable decisions. Hence why asking a publisher to replace certain jargon will result in a delayed revision at best.

Meanwhile, the manual and tedious process would include: purchasing a Portable Document Format (PDF) editing computer application such as Adobe Acrobat; finding all text instances of “master” and “slave” for example; then replacing all instances with the desired replacement terminology. This process will not work at all on image-only or scanned PDFs which are still commonplace in engineering classrooms. PDFs which lack text-based content are usually older and thus are the documents which contain outdated nomenclature.

Therefore, one material motivation of this research is to make way for engineering datasheets that no longer contain problematic terminologies. One proposed solution to this problem is a optical character recognition (OCR) algorithm which can accurately detect instances of problematic terminology and then overlay them with a more inclusive replacement terminology. This thesis concludes

with an investigation of this application of OCR in MATLAB in chapter 4. An in depth background and pedagogical case study are presented in Chapter 2 and Chapter 3.

Chapter 2

BACKGROUND

2.1 Curriculum Trauma

At its core, this thesis aims to pinpoint areas within engineering curriculum that may need improvement or updating. One theory which supports this audit is called *Curriculum Trauma* (CT) [2]. Founded by researchers, Abdimalik A Buul, Kisha Quesdad Turner, and Ebony Tyree, this academic theory was first published by the Academic Senate for California Community Colleges' 2020 Rostrum and is the focus of this thesis section [2].

CT is "an academic theory that critically examines the ways in which academic systems (i.e., curriculum) directly harm students' ability to become independent and healthy social agents" [2]. For the purpose of this thesis, the aspect of "curriculum" in question are the terminologies selected to describe various engineering fundamentals. Albeit a seemingly minuscule aspect of one's pursuit of an engineering degree, microaggressions within curriculum content may "impede student success from matriculation to graduation" [2]. Academic curriculum is

not exempt from being guilty of microaggressions, because, by definition, they often happen "automatically or unconsciously" [19].

A relevant manifestation of CT is the "erasure and neglect of cultural capital in the classroom" [2]. Why is it that when we first learn about legacy terminology in engineering named after white men, there is often a brief aside to acknowledge the origin of the word choice? But when we first learn about terms with more peculiar or uncomfortable origins, there is no historical acknowledgment or explanation. For instance, I can recall lectures and videos which explain how the Ohms, Amperes, and Volts units are the namesake of Georg Ohm, André-Marie Ampère, and Alessandro Volta. But I cannot recall anyone explaining the origins of "female-male" or "master-slave" when they first appeared in my curriculum.

To exemplify further, when I learned about the double slit experiment and related quantum phenomena in my physics courses, they often were paired with a historical account of the events leading up to the experiments' conclusions. However, no such historical context was provided when I first learned about "female-male" connectors or "master-slave" component relationships. In fact, history about the selection of "master-slave" for example is difficult to come across even with diligent research (refer to thesis section 3.2). These are some of the subtle examples of the neglect of cultural capital in engineering classrooms.

Hence, curriculum content in engineering such as "master-slave", "female-male", "blacklist-whitelist", and "black hat-white hat" indeed "lurks as one of the last pillared bastions that remains resistant to fundamental changes" [2]. The selectivity of educators explaining certain aspects of engineering historical context versus others begs the question: do we avoid confronting certain terms in engineering because they make some students feel uncomfortable?

2.2 Effects of Uncomfortable Engineering Jargon on Inclusivity

Fortunately, a formal study assessing the effects of "master-slave" terminology on inclusivity in engineering education ("preliminary study") was peer-reviewed and published in 2020 by Cal Poly researchers, Dr. Andrew Danowitz, myself (Amman Asfaw), Dr. Bridget Benson, Dr. Paul Hummel, and Dr. K. Clay McKell [1]. This preliminary study—which is the focus of this thesis section—serves as a foundation and starting point for the pedagogical research found in Chapter 3. Previously unpublished data pertaining to "black hat - white hat", "blacklist-whitelist", and "female-male" from the same preliminary study is provided in this thesis section as well.

Although the participant pool of the preliminary study lacks an ideal diversity of gender and race, it does somewhat represent the overall makeup of many engineering programs: largely white and male [1]. All students were either electrical engineering, computer engineering, or computer science majors. Fig. 2.1 and Fig. 2.2 both illustrate these demographic distributions.

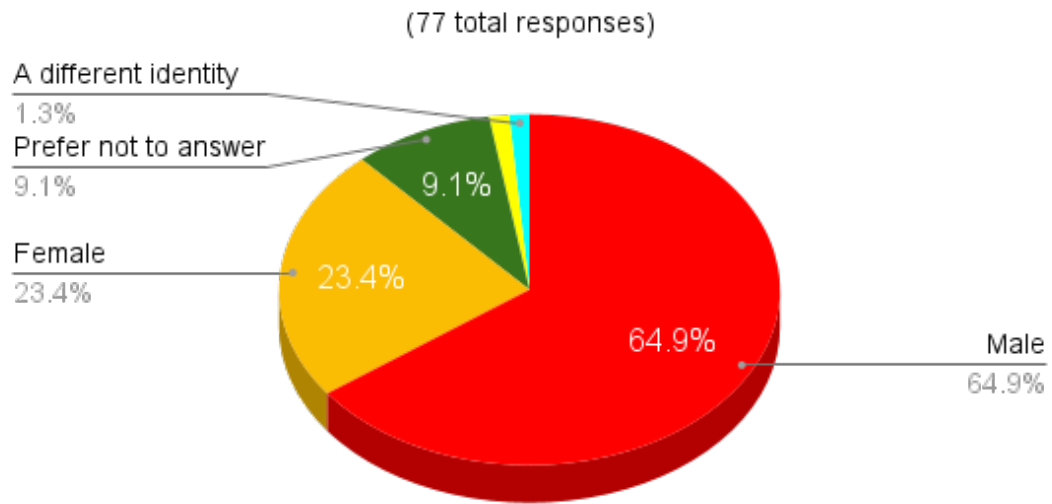

Figure 2.1: Demographic distribution of gender in the preliminary study (n=77) [1].

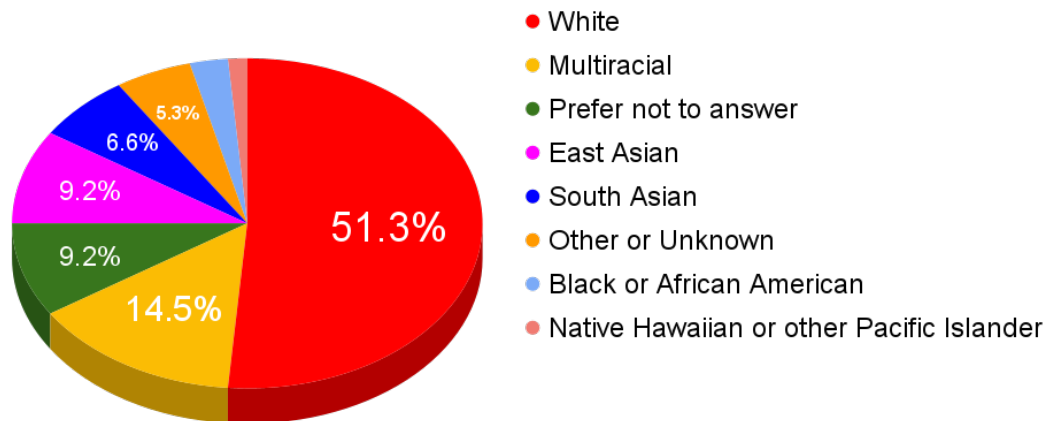

Figure 2.2: Demographic distribution of race in the preliminary study (n=77) [1].

Fig. 2.3 below shows 28.5% of students have never considered the impact of "master-slave" on others. Meanwhile 38.4% of students shared the same sentiments regarding "female-male". Whereas the majority of students have never considered the impact of "black hat - white hat" and "blacklist-whitelist". This is noteworthy, because it displays students' awareness of the potential implications of "master-slave" and "female-male", in particular.

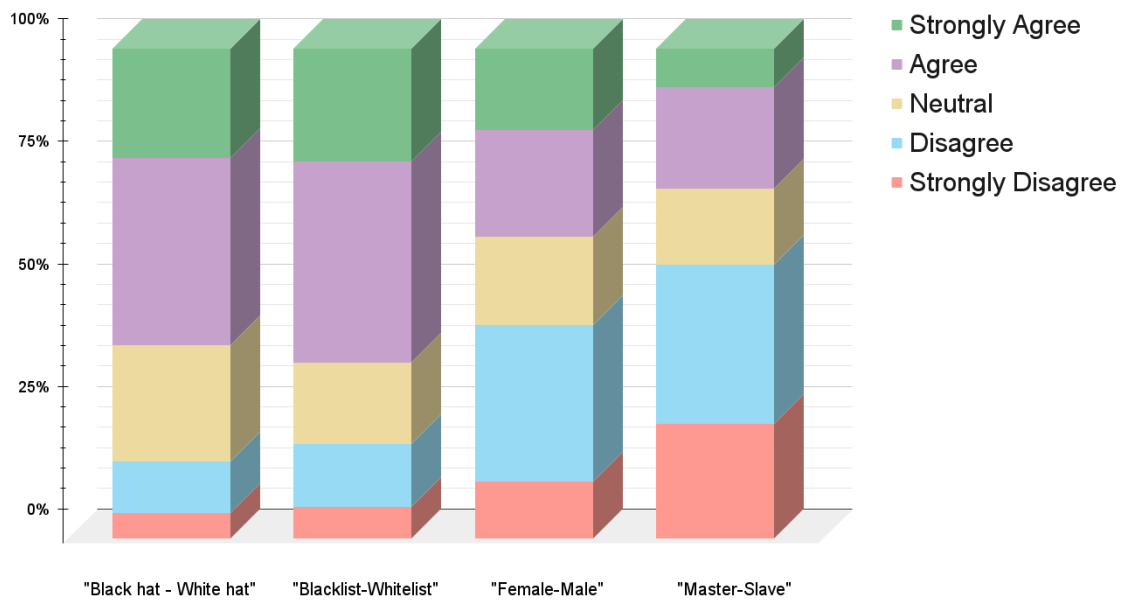

Figure 2.3: Survey responses when prompted "I have never considered the impact this terminology may have on others" [1].

Students then provided their level of discomfort with specific terminologies, as shown in Fig. 2.4. Most students reported little to no discomfort with "black hat - white hat" and "blacklist-whitelist". However, 42.9% and 21.7% reported some level of discomfort with "master-slave" and "female-male", respectively. It is important to note that all 9 women-identifying and both Black-identifying

students surveyed either agree or strongly agree that use of "master-slave" makes them feel uncomfortable [1].

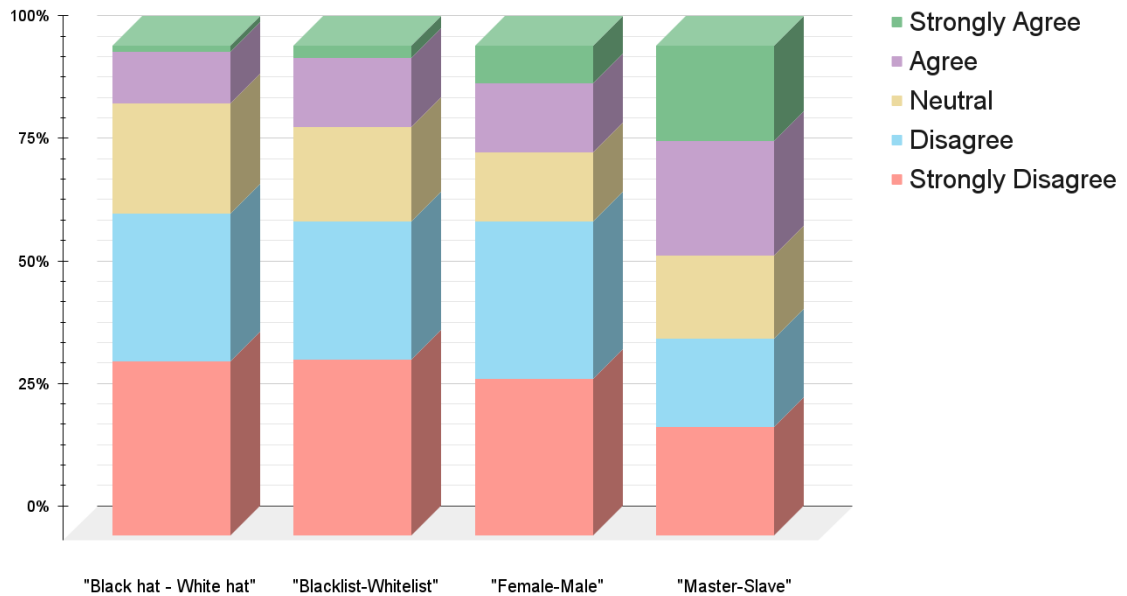

Figure 2.4: Survey responses from the preliminary study when prompted "The use of this terminology makes me feel uncomfortable" [1].

Since it is evident some students feel uncomfortable with certain engineering jargon, it is logical to probe whether students who are comfortable would feel empathetic towards their peers who feel otherwise. The data in Fig. 2.5 displays an encouraging amount of empathy, with roughly half of all students reporting at least some interest in empathizing.

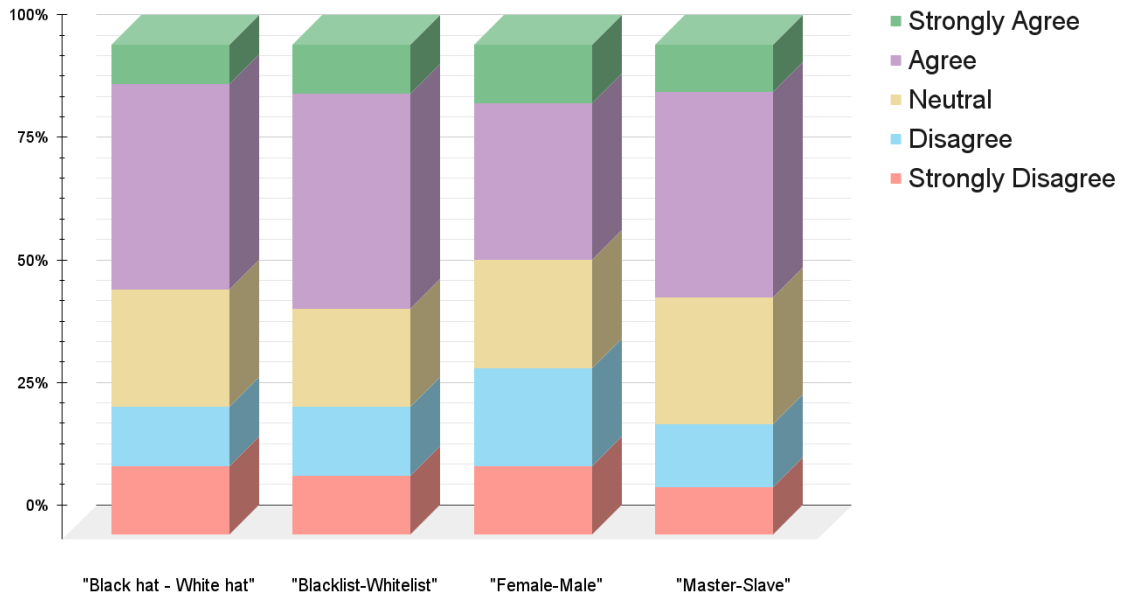

Figure 2.5: Survey responses from the preliminary study when prompted "I would feel empathetic towards a classmate who finds this terminology problematic" [1].

The next question of interest is whether students would accept an entirely new terminology—not just feel empathetic. The responses in Fig. 2.6 unsurprisingly show similar sentiments as Fig. 2.5, with nearly half of all students expressing their willingness to embrace an alternate phrase for all four of the terminologies of interest. "Female-male" however, shows the least interest in replacement acceptance.

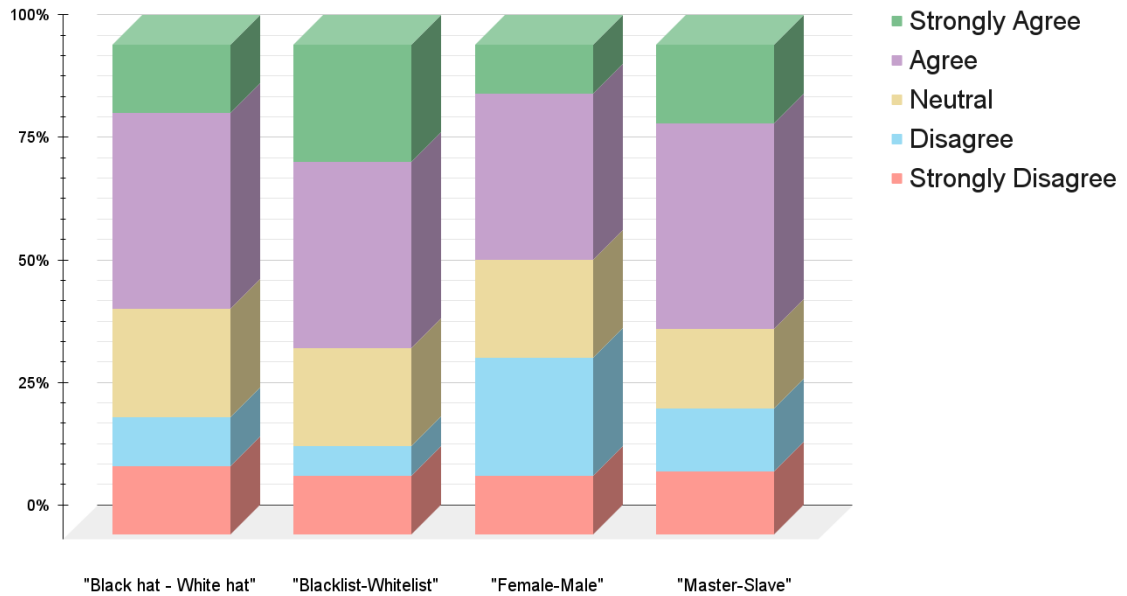

Figure 2.6: Survey responses from the preliminary study when prompted "I would accept using an alternate phrase if a classmate expressed discomfort with the use of this terminology" [1].

The preliminary study concludes with a recommendation for future researchers to research an approach where problematic terminology in engineering curriculum is confronted, addressed and replaced [1]. This charge turned into an even more detailed study ("case study") which is presented next in Chapter 3.

Chapter 3

CASE STUDY: THE C.A.R. (CONFRONT, ADDRESS, REPLACE) STRATEGY APPLIED TO “MASTER-SLAVE”

3.1 Introduction

This case study follows to the April 2020 study reviewed in the previous section which confirmed “master-slave” terminology may create classroom conditions to evoke Stereotype Threat [1].

Engineering enrollment rates in Bachelor’s, Master’s, and Doctoral programs for Black/African-American and Hispanic students are much lower than their

demographics in the United States [3], [20]. These race and ethnicity terms were chosen for this study by research advisors, because they align with the most inclusive categorizations and the categories of the United States census. Likewise, women-identifying engineering students account for about 25% of students in Bachelor’s, Master’s, and Doctoral engineering programs in the U.S. but women-identifying individuals make up 50.8% of the U.S. population [3], [20].

Although these disparities have shrunk in the last 40 years, the current underrepresentation of women-identifying students as well as Black/African-American and Hispanic-identifying engineering students is still a compelling national interest in the U.S. [21]. Decreasing disparity gaps among students from underrepresented and minoritized groups who matriculate through engineering programs can lead to more economic opportunities for these students and help eradicate national concerns such as the racial wealth gap [22]. Stereotype Threat also explains why this retention gap is so large and how institutions are continuing to enable unwelcoming climates for members of historically excluded backgrounds [1]. Thus, policies, programs, and pedagogy focused on intentionally eradicating underrepresentation of women and racial/ethnic minorities in American engineering education are necessary.

One key concern for increasing the number of underrepresented engineering students is the lack of a sense of belonging those students may feel while enrolled as a student. Previous research shows that a lack of strong sense of belonging in higher education is a common reason for the early withdrawal of ethnic minority students [23]. In fact, students who find few peers in their class—often underrepresented ethnic groups and women—“tend to feel much more strongly that they don’t belong” [24] so a lack of community can deter underrepresented students from pursuing engineering in the first place.

The CAR Strategy is one pedagogy that intends to contribute to eradicating underrepresentation of racial/ethnic minorities in engineering. It aims to provide a framework for driving out non-inclusive terminologies in engineering education such as “master-slave.” This paper reports specifically on student perceptions and the effectiveness of The CAR Strategy piloted as a teaching framework in the computer engineering department of a Predominantly White Institution (PWI) in California.

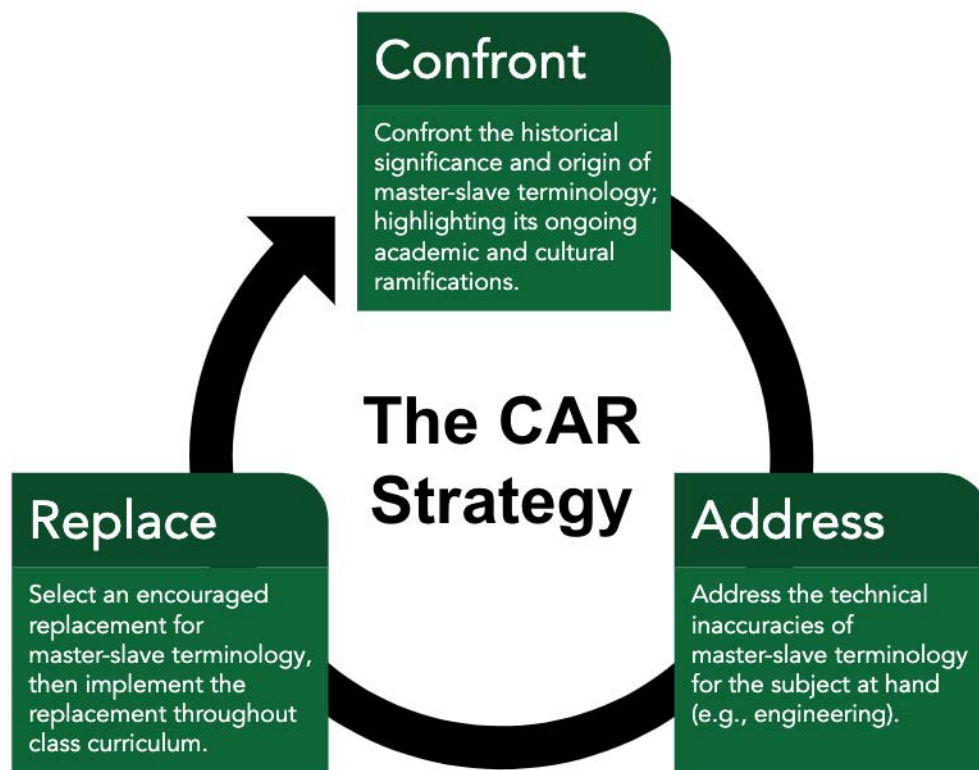

Figure 3.1: Visual graphic of The CAR Strategy: 1) confront; 2) address; and 3) replace as applied to “master-slave” terminology.

The CAR Strategy, summarized in Fig. 3.1, consists of three steps and stands for: 1) confront; 2) address; 3) replace. The first step in this strategy is to confront

the historical significance of problematic terminology. By educating students, professors, and those in industry about the historical origins and implications of the terminology, folks in academia and industry will better understand why the terminology may discomfort some [1].

The second step in The CAR Strategy is to address the technical inaccuracies of problematic terminology. For example, in most cases where "master-slave" is used, it does not properly describe the relationship between certain mechanics in software and hardware. For example, in a Domain Name System (DNS) the "slave" can actively refuse to execute zone transfers if they are malformed despite the original direction coming from the "master" [25]. This example is noteworthy, because human slaves do not typically have the option to refuse a task assigned by their human master without severe consequences.

The final step of this strategy is to replace problematic terminology with a recommended replacement terminology. Replacing "master-slave" not only prevents students from feeling uncomfortable [1], but the replacement terms can also be made to more accurately describe the process happening within software or hardware.

Another way to conceptualize The CAR Strategy is to confront the past, address the present consequences, and replace problematic terminologies for the future. More importantly, I hypothesize that the replacement of "master-slave" will help to cancel the normalization of terminologies which reify racial hierarchies.

3.2 Historical Background

The earliest appearances of “master-slave” terminology in technical settings occurred in 1904 [26]. Since then, the use of “master-slave” terminology has increased substantially in describing engineered systems. It is not clear who first coined the terminology. Today, “master-slave” can be found in engineering topics such as brake/clutch cylinder systems in car engines, serial peripheral interface connections in microcontrollers, online git repositories, aeronautical missile systems, computer network database architectures, architectural designs of residential homes, and more [27], [28], [29], [30], [31], [32].

“Master-slave” terminology is correlated with feelings of exclusion and Stereotype Threat for students. This creates an uncomfortable atmosphere in the classroom and can potentially prevent students from actively engaging and asking questions in class [1]. In computing systems, “master-slave” terminology is frequently used to describe how flip-flops function. According to Eglash’s research, many Black engineers felt that such terminology does not conceptually make sense as a descriptor [26]. Furthermore, from this research it was revealed that in real industry settings, the “master-slave” relationship is not even apparent according to those same Black engineers [26]. Highlighting this inaccuracy with “master-slave” is important, because academia should strive to use nomenclature that is accurate and comfortable for all students to use—not just white and/or male students who have the privilege to feel comfortable accepting the “master-slave” metaphor [1].

However, “master-slave” is not the only type of problematic terminology commonly used in engineering. Terms like “whitelist/blacklist” , and even “male/female” have been labeled as problematic terminologies by many in the industry

today [33]. In fact, “whitelist/blacklist” has already been labeled so problematic that many major technical organizations and companies have vowed to replace and actively stop using such engineering jargon going forward [34]. Although industry is aware of and promising to replace terminologies like “master-slave,” there is still a need for The CAR Strategy, because undergraduate curriculum contributes to the development of industry-ready engineers. Additionally, The CAR Strategy ensures we are not simply erasing and replacing “master-slave,” but also confronting its past and addressing its present so engineers do not make similar mistakes in the future.

While some may argue that the terminologies discussed are not necessarily exclusionary in nature, previous research has concluded that if the language reminds someone they belong to a historically excluded group, it could lead to an overall negative academic performance for those individuals [35].

Even though some within industry realized the problem of “master-slave” and vowed for systemic changes, academia still needs The CAR Strategy, because academia falls short in addressing these systemic changes. In the scope of this paper, we focus on “master-slave” in engineering terminologies as the starting point of confronting, addressing, and replacing non-inclusive terminologies in engineering education.

Many past studies take the approach of analyzing how learning environments lead to underrepresented groups leaving STEM fields [36]. However, our study takes the approach of specifically focusing on student perceptions and efficacy of a new teaching strategy meant to confront, address, and replace “master-slave” terminology and similar iniquitous terminologies which have previously shown to create discomfort amongst students [1]. This study embodies true engineering

education reform and hopes to serve as a foundation or inspiration for future anti-racist pedagogies.

The CAR Strategy is a mechanism aiming to improve retention rates of underrepresented students by reducing the negative impacts caused by the presence of “master-slave” terminology on student retention and belonging, as well as student learning.

3.3 The CAR Strategy

The first step of The CAR Strategy—confront—advises instructors or guest lecturers to confront the historical significance of “master-slave” terminology and other exclusive terminologies. For example, discussing American slavery and sex trafficking is one way to accomplish this. Confronting the history of U.S. enslavement is the first step of The CAR Strategy when applied to “master-slave,” because it establishes the historical context and present day consequences to students who may believe metaphor terminology in engineering education does not matter and/or is not worth discussing in an engineering course. Considering 42% of students in the April 2020 study agreed the use of “master-slave” terminology makes them feel uncomfortable, it is reasonable to assume that discussing this topic will result in an uncomfortable conversation for a class to discuss [1]. Having this uncomfortable conversation is important, because it will prompt students to think about how this terminology can make their fellow peers feel uncomfortable and excluded in learning environments.

The second step of The CAR Strategy—address—requires instructors to address the specific technical inaccuracies of “master-slave” terminology for the subject they are teaching. This second step is chosen, because the 22% of students

in the previous study who did feel comfortable with the problematic terminology [1] may need to see or hear technical reasonings to personally justify a change to the terminology.

The third and last step of The CAR Strategy—replacement—recommends instructors as well as their students select a preferred replacement for “master-slave” terminology. Since the majority of students in the 2020 study who felt uncomfortable with the “master-slave” nomenclature were also in agreement with the idea of replacing “master-slave” terminology in the classroom, officially replacing the nomenclature seems to be an appropriate solution [1].

This case study attempts to determine whether The CAR Strategy is a legitimate and effective strategy professors can use to replace iniquitous terminology such as “master-slave” within engineering education. Specifically, this study focuses on if and how The CAR Strategy may change student opinions regarding “master-slave” terminology as well as their perceptions on the CAR teaching strategy. Lastly, this study will discuss which alternative terminologies CAR participants found promising for “master-slave”.

3.4 Survey Design

This section details the design of our pilot program, survey instruments, and statistical analysis. The CAR Strategy is consolidated into a three minute and forty five second video which serves as the implementation of the teaching strategy [18]. Before students are sent the video, students voluntarily fill out a Google Forms survey which is denoted as the pre-CAR survey. Then, once the video is watched, students may voluntarily fill out a second Google Forms survey which is denoted as the post-CAR survey. The pre-CAR and post-CAR surveys are

exactly the same except for the additional post-CAR survey questions shown in Table 5. Filling out the surveys and watching The CAR Strategy video are completed asynchronously and remotely. From start to finish this trial of The CAR Strategy requires approximately a total of 15 to 25 minutes of a students' time depending on how long they take to fill out the surveys.

In both surveys, a Likert scale [37] is used to assess the student's familiarity with the engineering terminology "master-slave", whether they have ever considered the impact the term may have on others, and whether the term makes them personally feel uncomfortable as shown in Table 3.1. The respondents either respond with "Strongly Disagree", "Disagree", "Neutral", "Agree", "Strongly Agree", or "Prefer not to answer". Depending on their response to the last question in this section, the survey's logic sends respondents to another set of questions about the term.

Question ID	Question	Type
B1	I am familiar with the engineering terminology "master-slave."	Likert agreement
B2	I have never considered the impact "master-slave" terminology may have on others.	Likert agreement
B3	The use of "master-slave" terminology makes me feel uncomfortable.	Likert agreement

Table 3.1: Questions asked to all respondents in the beginning of the pre-CAR and post-CAR surveys.

If a respondent agrees, strongly agrees, is neutral, or prefers not to answer that “master-slave” makes them feel uncomfortable, the survey asks the questions shown in Table 3.2. The questions address Stereotype Threat by asking respondents if the jargon reminds them of being part of a historically marginalized group. They also attempt to determine how the use of the terms affect the sense of inclusivity and any feelings related to Curriculum Trauma [2].

Question ID	Question	Type
C1	Use of the term reminds me I’m part of a historically excluded group.	Likert agreement
C2	Use of this term makes me feel like an outsider in the classroom.	Likert agreement
C3	I’m afraid of how my classmates might feel about this term.	Likert agreement

Table 3.2: Questions asked of respondents if they answer “Strongly agree”, “Agree”, “Neutral”, or “Prefer not to answer” to whether “master-slave” terminology makes them feel uncomfortable.

For students who are not made uncomfortable by the use of a term, we ask the questions shown in Table 3.3. These questions aim to capture the viewpoints of students who do not find “master-slave” a discomfoting terminology. Specifically, the questions hone in on the extent to which students feel empathetic towards their peers who feel differently. Additionally, the last question of this section assesses students willingness to a potential change in curriculum.

Table 3.3: Pre-CAR and post-CAR questions asked of respondents if they answer "Strongly Disagree" or "Disagree" to whether "master-slave" terminology makes them feel uncomfortable.

Question ID	Question	Type
D1	I would be surprised if a fellow student mentioned discomfort with this term.	Likert agreement
D2	I would feel empathetic towards a classmate who finds this term problematic.	Likert agreement
D3	I would accept using an alternate phrase if a classmate expressed discomfort with the use of this term.	Likert agreement

The next section of the survey is asked to all respondents and solicits perceptions of The CAR Strategy. As shown in , three questions are asked, each one related to each step of The CAR Strategy. Each question also allows students to elaborate on their opinions with an open ended question.

Table 3.4: Questions asked to all respondents in both the pre-CAR and post-CAR surveys.

Question ID	Question	Type
E1	Professors should appropriately confront the historical significance and origins of “master-slave” terminology in courses that traditionally use the term.	Likert agreement
E2	Care to elaborate?	Long answer
F1	“Master-slave” terminology is an accurate description of the engineering systems it represents.	Likert agreement
F2	Care to elaborate?	Long answer
G1	Which alternative terminology would you prefer to replace “master-slave?”.	Multiple choice
G2	Care to elaborate?	Long answer

The post-CAR survey contains additional questions which are not present in the pre-CAR survey. As shown in Table 3.5, these questions aim to gauge the efficacy of The CAR Strategy as a new pedagogy by asking one question for each step of the strategy and three general questions on the strategy as a whole.

Table 3.5: Questions asked to all respondents in only the post-CAR survey.

Question ID	Question	Type
E3	The CAR Strategy appropriately confronted the historical significance and origins of “master-slave” terminology.	Likert agreement
F3	The CAR Strategy helped me realize the technical inaccuracies of “master-slave” terminology.	Likert agreement
G3	I was satisfied with the replacement terminology my professor selected through The CAR Strategy.	Likert agreement
H1	Overall, I believe The CAR Strategy is an effective framework for aiming to drive out iniquitous terminologies such as “master-slave” in STEM education.	Likert agreement
H2	I would like to see all my professors use The CAR Strategy (when applicable) in my classes.	Likert agreement
H3	What positive or negative feedback do you have on The CAR Strategy?.	Long answer

Last in the survey, we ask the demographic questions shown in Table 3.6. We include the demographic questions at the end of the survey to avoid priming students to think about their identity before engaging with the term “master-

slave”. The last question in this section is optional and allows us to link pre-CAR and post-CAR responses to better analyze data.

Table 3.6: Pre-CAR and post-CAR demographics questions for all respondents. These questions were asked at the end of the survey to avoid introducing Stereotype Threat.

Question ID	Question
J2	Are you the first person in your immediate family to attend college?
J3	What is your gender/gender identity?
J4	How would you describe your race or ethnic identity?
J5	What are the last 5 digits of your Library Code on the back of your student identification card?

3.5 Statistical Methods

Aside from the pie charts and bar graphs that can be made from the pre-CAR and post-CAR datasets separately, this case study implements a more sophisticated statistical analysis to examine a third dataset. This third dataset, denoted as the “linked-CAR dataset”, comprises students who fill out both the pre-CAR and post-CAR surveys and twice enter the same five digit library code from their student identification card.

From the linked-CAR dataset, the statistical software, Minitab, is used to conduct paired t-hypothesis tests while the programming environment, MATLAB, is used to plot the linked-CAR dataset responses onto alluvial diagrams.

The paired t-test is a form of hypothesis test in statistics used when interested in the difference between two variables for the same subject; often the two variables are separated by time [38]. Each paired t-test specifies a null hypothesis and alternative hypothesis in terms of the survey question of interest. All null hypotheses are defined as there being no change, on average, in a student's responses to a question before and after exposure to The CAR Strategy. All alternative hypotheses are defined as there being a change towards inclusivity, on average, in a student's responses to a question before and after exposure to The CAR Strategy. For this study, The CAR Strategy's effect on a given survey question is considered statistically significant if the paired t-test produces a p-value that is less than or equal to the alpha ($\alpha = 0.05$). If the p-value is less than or equal to alpha, the null hypothesis can be rejected, and thus the alternative hypothesis is accepted. Likewise, if the p-value is greater than alpha, the null hypothesis cannot be rejected, and the alternative hypothesis is rejected. In order to calculate the p-value the Likert scale is converted from strongly disagree, disagree, neutral, agree, and strongly agree to numerical values of 1, 2, 3, 4, and 5.

MATLAB is used to produce alluvial diagrams for each survey question for which The CAR Strategy is proven statistically significant. Alluvial diagrams, also known as alluvial plots, illustrate the data patterns and relationships between adjacent sample data [39]. In this study, a custom MATLAB program is utilized to produce alluvial plots which visually connect linked-CAR dataset one question at a time. The left side of an alluvial diagram designates student responses to questions in the pre-CAR survey while the right side of an alluvial diagram designates the same students' responses to the same question in the post-CAR survey. For each alluvial plot the sample size (n) varies, because some survey

questions had fewer respondents due to the two possible respondent paths in the pre-CAR and post-CAR surveys. In this study, alluvial diagrams serve to help readers better comprehend and notice the effect The CAR Strategy has on students before and after exposure to the new pedagogy.

3.6 Quantitative Results

The CAR Strategy surveys were distributed to electrical and computer engineering students at California Polytechnic (Cal Poly) State University enrolled in Microcontroller-Based Systems Design during the Spring term 2020. A total of 94 and 65 students responded to the pre-CAR and post-CAR surveys, respectively. The demographics of the respondents are shown in Fig. 3.2 and Fig. 3.3. Per Institutional Review Board requirements, we did not require a response for any question. Therefore, the number of respondents varies per item.

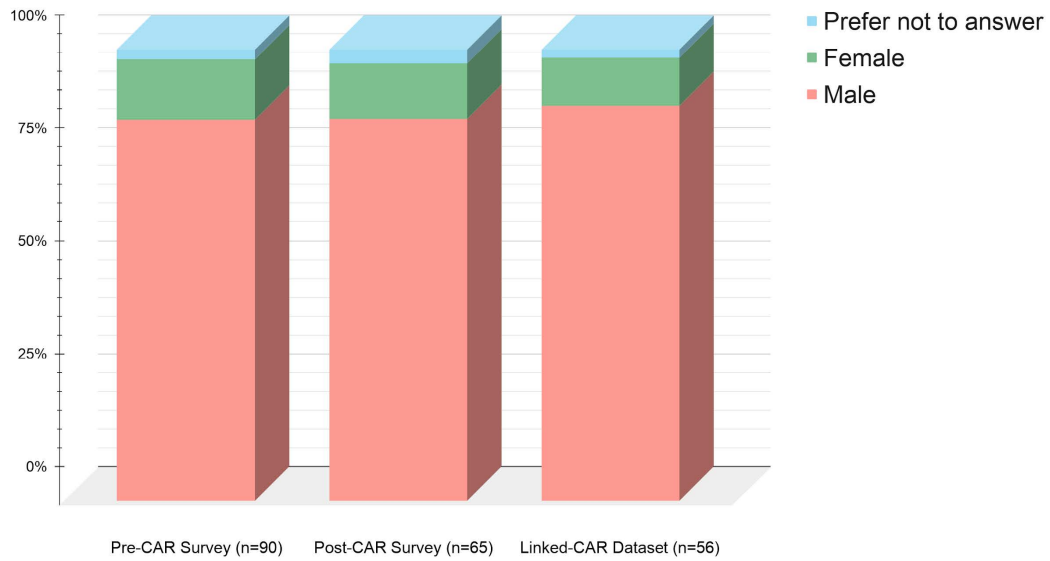

Figure 3.2: Demographic distribution of gender in the pre-CAR, post-CAR, and linked-CAR datasets.

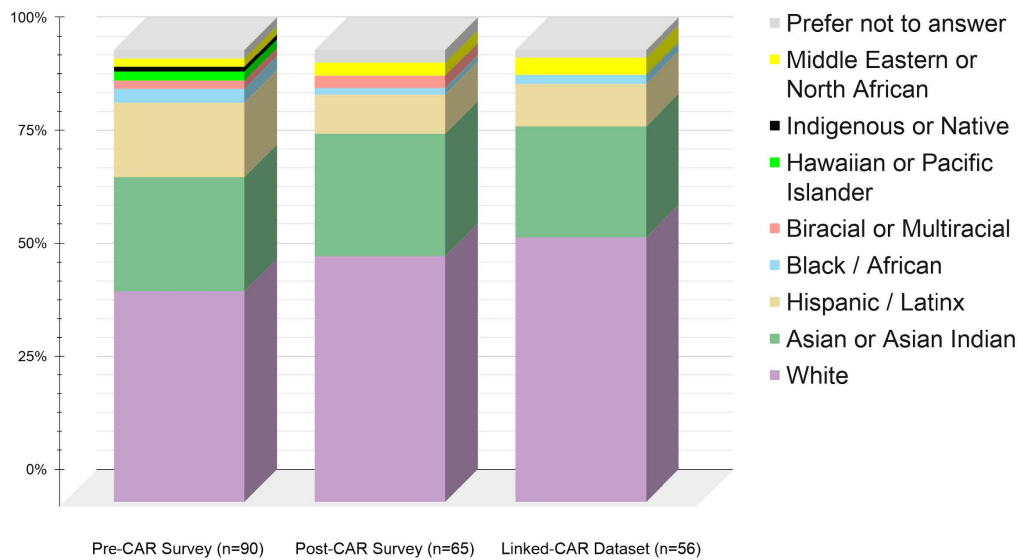

Figure 3.3: Demographic distribution of race in the pre-CAR, post-CAR, and linked-CAR datasets.

The respondent population is predominantly white and male which is representative of the student population at Cal Poly and its College of Engineering [40]. Although these demographics are not ideal for representing diverse perspectives on The CAR Strategy, the numbers are also somewhat representative of the overall makeup of many electrical engineering and computer engineering programs nationwide. Besides, one of the end-goals of The CAR Strategy is to ultimately increase the diversity and improve retention within engineering programs. Time and further research will tell whether the pedagogy can accomplish these goals. Nonetheless, the results should be valuable in measuring current student sentiment as it exists overall.

The overall results for the questions in both the pre-CAR and post-CAR surveys shows promising statistics on students' perceptions of The CAR Strategy. As shown in Fig. 3.4, of all 64 post-CAR respondents, 70% either agree or strongly agree The CAR Strategy is an effective framework for driving out iniquitous terminologies such as "master-slave" in engineering education. Similarly, as shown in Fig. 3.4, 67% of post-CAR respondents either agree or strongly agree they would like to see all professors use The CAR Strategy when applicable in their classes.

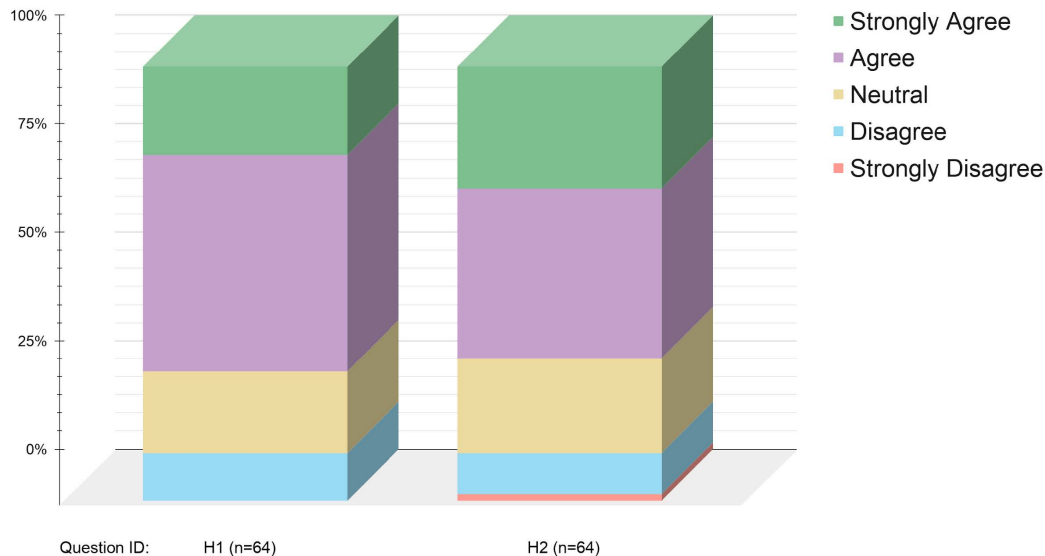

Figure 3.4: Distribution of responses for questions H1 and H2² from Table 3.5.

Moreover, after exposure to The CAR Strategy, respondents felt strongly about how well the pedagogy executed its purposes in each step. For the “confront” step, of all 64 post-CAR respondents, 85.9% either agree or strongly agree The CAR Strategy appropriately confronted historical significance and origins of “master-slave” terminology (E3post). While for the “address” step, of all 64 post-CAR respondents, 68.2% either agree or strongly agree The CAR Strategy helped them realize technical inaccuracies of “master-slave” terminology (F3post). And lastly, for the “replace” step, of all 64 post-CAR respondents, 58.7% either agree or strongly agree they were satisfied with the replacement terminology their professor selected through The CAR Strategy.

²H1: Overall, I believe The CAR Strategy is an effective framework for aiming to drive out iniquitous terminologies such as “master-slave” in STEM education. H2: I would like to see all my professors use The CAR Strategy (when applicable) in my classes.

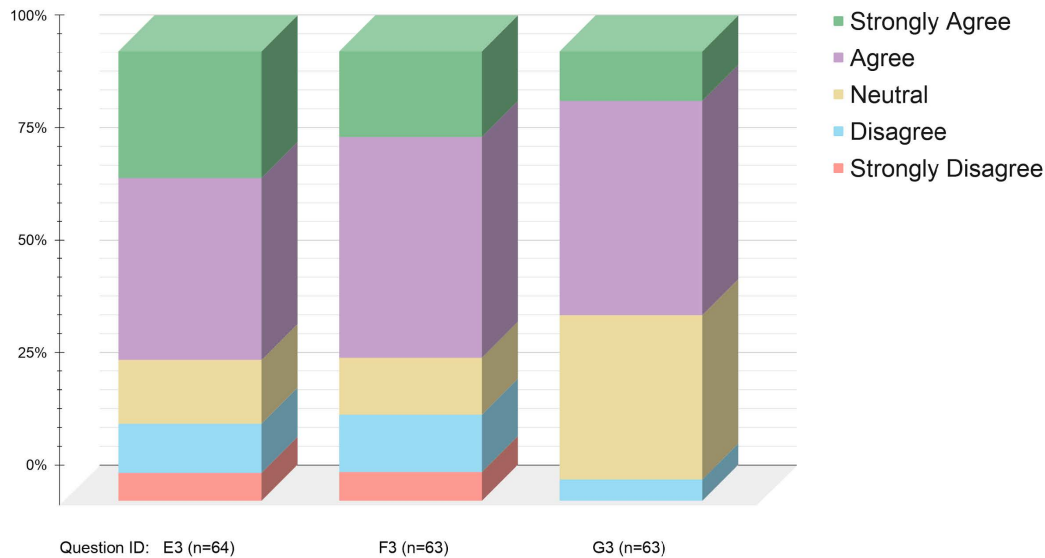

Figure 3.5: Distribution of responses for questions E3, F3, and G3⁴ from Table 3.5.

After running all 56 linked-CAR survey responses through ten different paired-sample hypothesis tests, The CAR Strategy provided sufficient evidence to suggest it is statistically significant (at confidence levels less than 5%) in promoting a more inclusive student experience.

Of the hypothesis tests run on the ten linked-CAR survey questions which assess The CAR Strategy, seven of the hypothesis tests achieved a rounded p-value of less than or equal to 0.05, as shown in 3.7. Each hypothesis test produced an “individual value plot of differences” to help visualize the differences in students’ change in responses before and after The CAR Strategy. Each data point represents a student’s numerical difference in their Likert-scaled responses to a

⁴E3: The CAR Strategy appropriately confronted the historical significance and origins of “master-slave” terminology. F3: The CAR Strategy helped me realize the technical inaccuracies of “master-slave” terminology. G3: I was satisfied with the replacement terminology my professor selected through The CAR Strategy.

question in the pre-CAR and post-CAR surveys where the difference is defined as the post-CAR value minus the pre-CAR value. The data shows clear trends on how exposure to The CAR Strategy affects student responses.

Question B1⁵ was determined not applicable to the hypothesis tests and thus omitted, because the vast majority of students were already familiar with “master-slave” engineering terminology prior to exposure to The CAR Strategy.

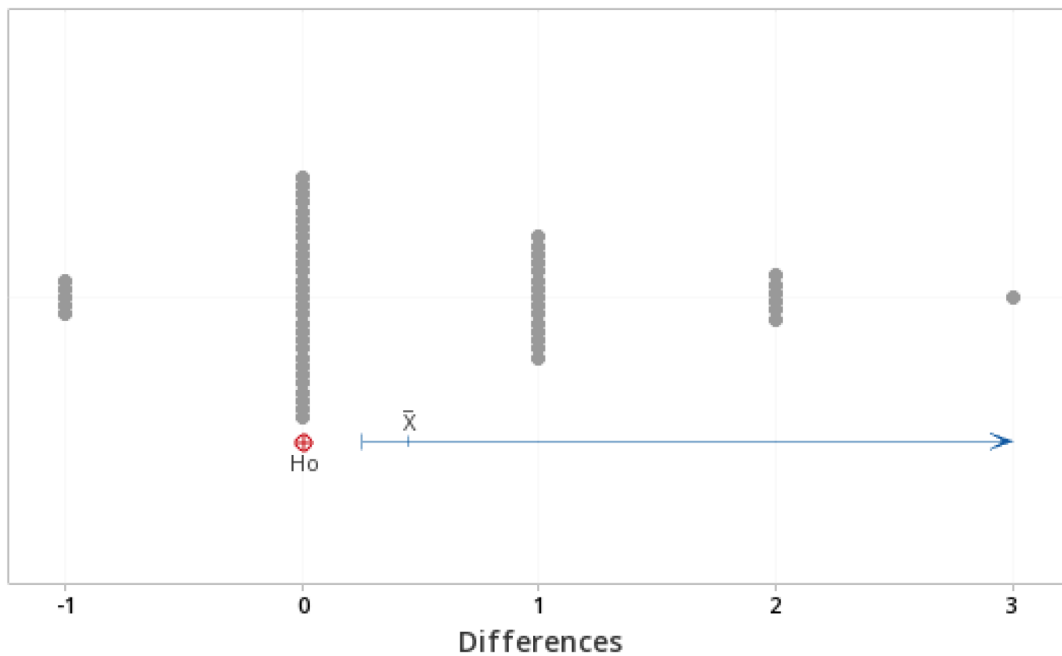

Figure 3.6: An example of the Minitab paired-sample hypothesis test’s “Individual Value Plot of Differences” for question B3⁷ (n = 56) from Table 3.1. Each data point represents a student’s numerical difference in their Likert-scaled responses to question B3⁷ in the pre-CAR and post-CAR surveys. The null hypothesis, Ho, claims that there is no difference in a student’s responses, and the mean of all differences, X-bar, equals 0.446.

⁵B1: I am familiar with the engineering terminology “master-slave”

⁷B3: The use of “master-slave” terminology makes me feel uncomfortable

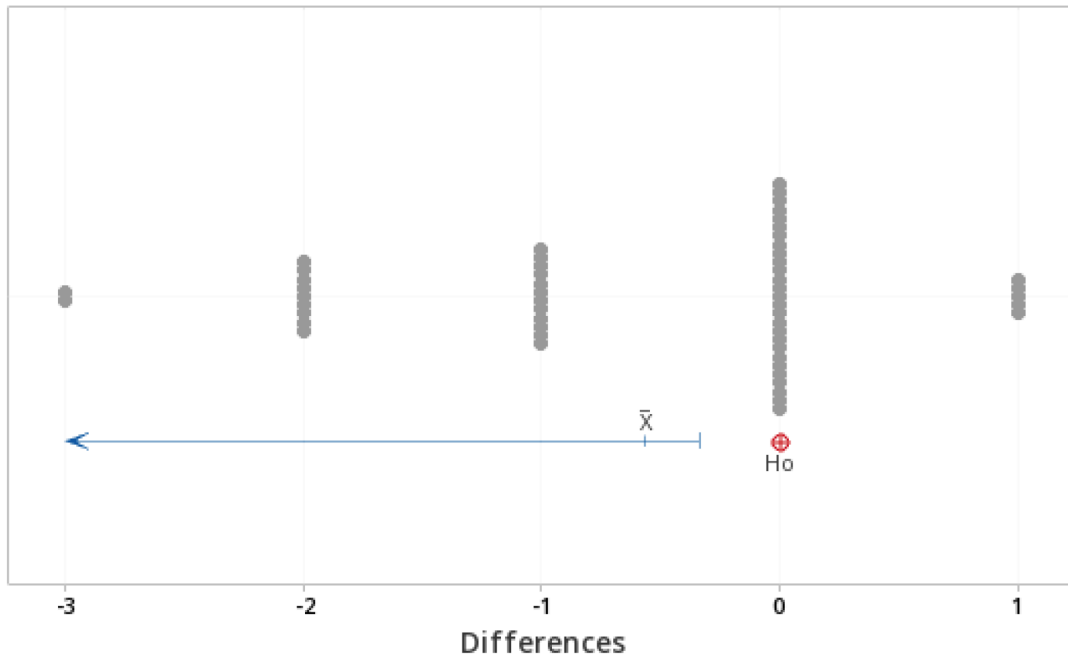

Figure 3.7: An example of the Minitab paired-sample hypothesis test’s ”Individual Value Plot of Differences” for Question F1⁹ (n = 55). X-bar equals -0.564.

⁹F1: “Master-slave” terminology is an accurate description of the engineering systems it represents.

Table 3.7: Statistical results of the paired-sample hypothesis tests conducted in Minitab. Asterisks denote the alternative hypothesis was accepted for that question’s hypothesis test. The precision of the p-value was set to the thousandths place.

Question ID	Respondent Sample Size (n)	Hypothesis Test Probability Value (p-value)
B2*	56	0.006
B3*	56	0.000
C1	34	0.101
C2*	34	0.001
C3*	34	0.007
D1	13	0.134
D2	13	0.027
D3	13	0.169
E1*	56	0.051
F1*	56	0.000

Once again, the statistical results above help to solidify and confirm the efficacy of The CAR Strategy as an experimental teaching framework. MATLAB is used to produce alluvial diagrams which better visualize the overall effect of The CAR Strategy.

Of the six alluvial diagrams produced, three can be found below in Fig. 3.8, Fig. 3.9, and Fig. 3.10. The remaining three diagrams are appended in Chapter 6. The left side and right side of the diagrams represent the pre-CAR and post-CAR survey responses. The lengths of the black bars on each side of the diagrams are approximate indicators of the responses for each survey. For the purpose of

the alluvial diagram, “strongly disagree” and “disagree” responses are grouped into a singular “Disagree” category while “strongly agree” and “agree” responses are grouped into a singular “Agree” category. The diagrams illustrate any shifts and trends amongst students who completed both surveys. Nearly all student shifts, except for a few outliers, either shifted towards promoting a more inclusive classroom setting.

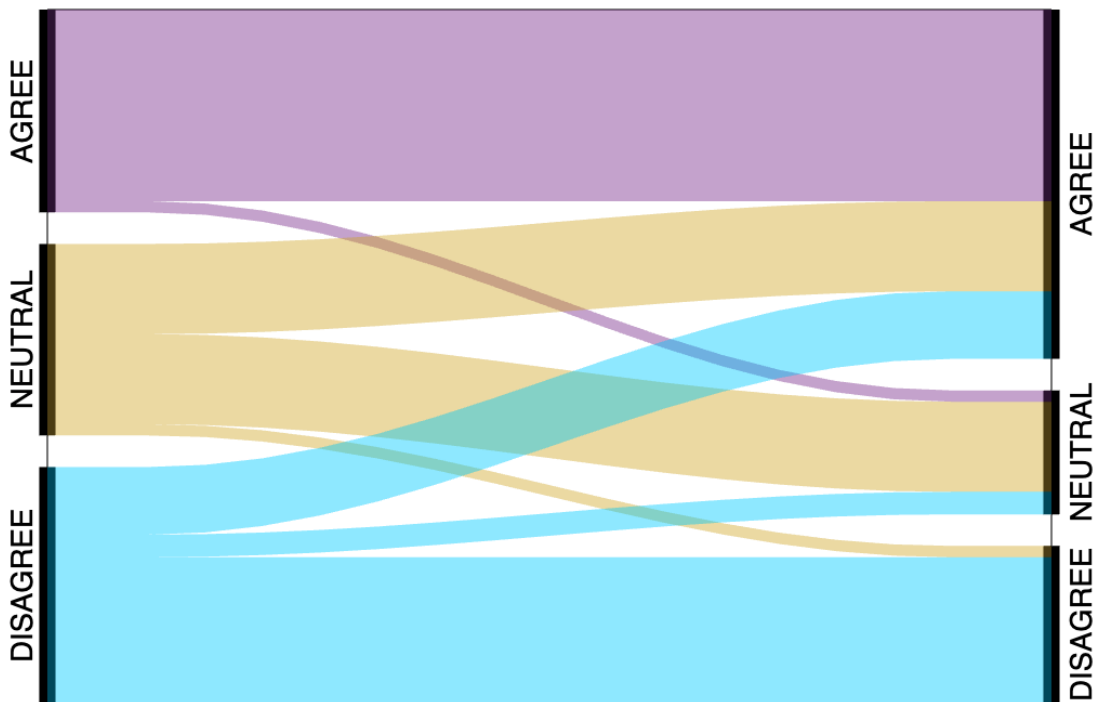

Figure 3.8: Survey responses for question B3¹¹ (n = 56), from Table 3.1, before and after The CAR Strategy.

¹¹B3: The use of “master-slave” terminology makes me feel uncomfortable.

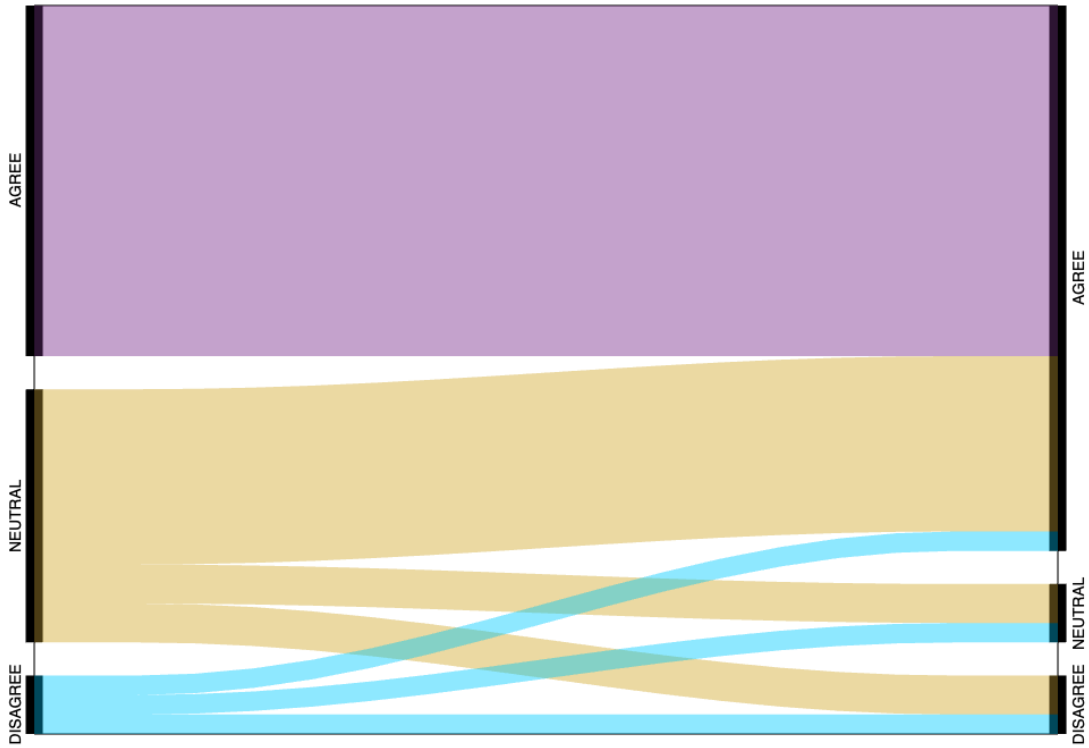

Figure 3.9: Survey responses for question C3¹³ (n = 34), from Table 3.2, before and after The CAR Strategy.

¹³C3: I'm afraid of how my classmates might feel about this term.

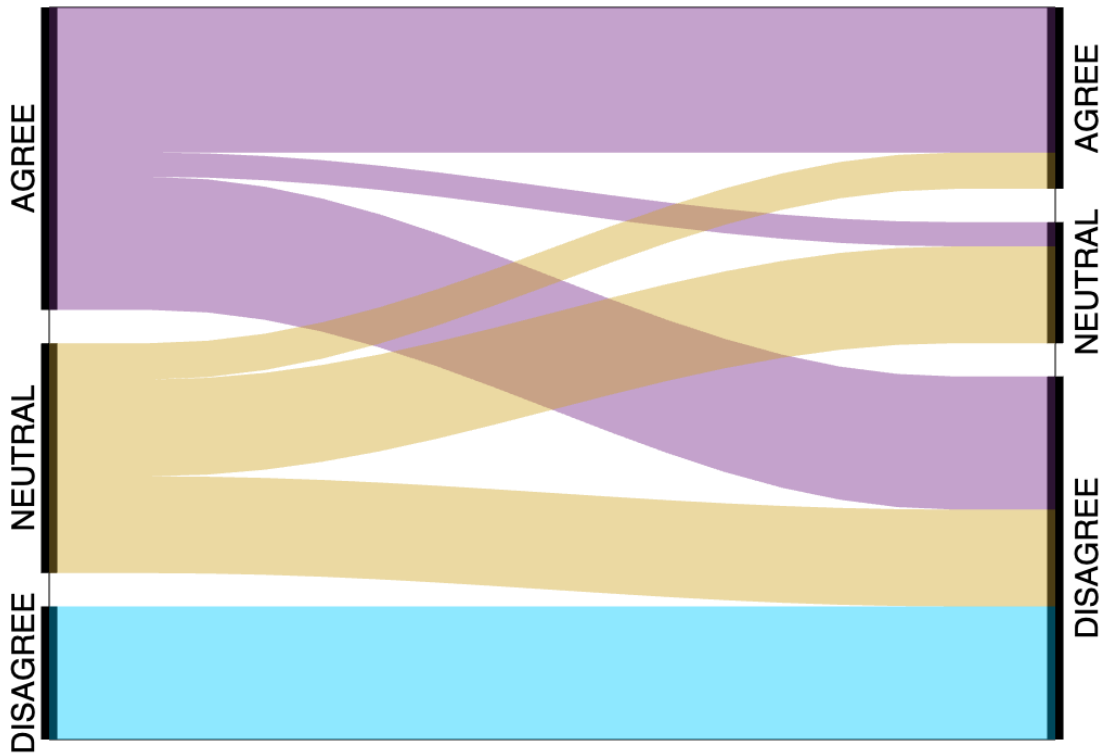

Figure 3.10: Survey responses for question F1¹⁵ (n = 55), from Table 3.4, before and after The CAR Strategy.

Lastly, in question G1¹⁶, from Table 3.4, students were asked which replacement terminology they prefer. As shown in Fig. 3.11, there was no dominating consensus in either the pre-CAR or post-CAR survey.

¹⁵F1: “Master-slave” terminology is an accurate description of the engineering systems it represents.

¹⁶G1: Which alternative terminology would you prefer to replace “master-slave?”

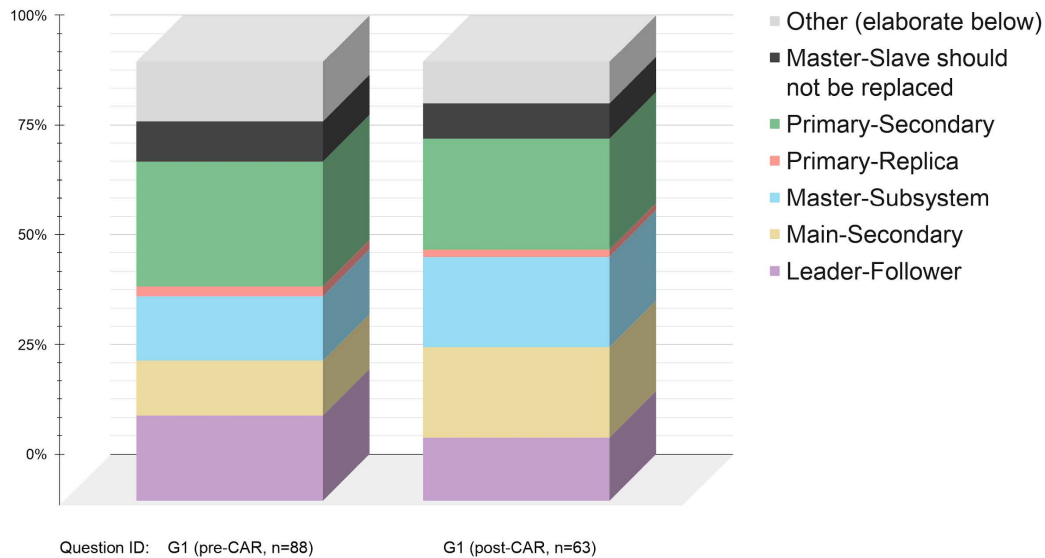

Figure 3.11: Distribution of responses for question G1, from Table 3.4, in the pre-CAR and post-CAR surveys.

3.7 Qualitative Results

In addition to the quantitative data above, qualitative data was collected from open-ended questions E2, F2, and G2 (Table 3.4). There were some responses in support of keeping the legacy terminology, but the majority of open-ended responses were in support of replacing “master-slave”. However, in both surveys there was no consensus on one single replacement terminology. For context, only 37% and 18% of open-ended questions received responses from students in the pre-CAR and post-CAR surveys, respectively. There were exactly 100 and 48 separate open-ended responses in the pre-CAR and post-CAR surveys, respectively, ranging from one-word to paragraph-long responses.

In the pre-CAR survey, several students voiced opinions such as “we should question our casual use of the term master/slave in embedded systems” and “it is better for teachers to address the elephant in the room instead of acting like [uncomfortable terminology] is no big deal.” Others went further and suggested “they should just come up with a replacement [terminology].”

Many of the comments in the pre-CAR survey displayed thorough critical thinking skills by the students. Topics such as slavery, history, and personal experiences were mentioned in multiple different comments. Some notable words appeared frequently in questions E2, F2, and G2 (Table 3.4) of the pre-CAR survey such as “uncomfortable”, “context”, “offensive”, and “connotation”. Most respondents in the pre-CAR survey shared the sentiment that they understand what “master-slave” technically means as an engineering terminology but there is likely a better way to describe it.

In the pre-CAR survey there were only a few students with opinions dissenting from the majority. These students made points such as “[going] over an entire history of slavery to be able to use the terminology would be a waste of class resources” and “I don’t know if an engineering professor has the expertise to properly bring up [the historical significance of ‘master-slave’].” One student even goes as far as to say “these [terms] have to do with computers, which have no history of oppression.”

It is interesting to note that in the pre-CAR survey several students recalled their first interactions with “master-slave” in engineering. One student said “I actually thought someone was making a weird joke on terminology” while another said “I found this to be a weird thing to see on a power supply, but after the initial shock I understood what it meant.” A third student wrote “I first discovered this terminology in industry on [an] internship and it made me feel uncomfortable.”

Furthermore, the post-CAR survey contained positive feedback along the lines of “I liked how the [CAR Strategy] video was a step by step solution to this societal issue” and “confronting the issue and acknowledging it in the classroom is a valuable learning experience”

There was also some negative pushback on the pedagogy such as “anthropomorphizing things is extremely common and can often help people understand new concepts faster” and “it is important to remember the violations of the past, and replacing anything that reminds us of [the past] helps obfuscate those violations.”

But for the most part, students’ comments in the post-CAR survey provided direction for future research related to The CAR Strategy and the gaps it currently does not address. “[The CAR Strategy] can be applied to many other engineering or non engineering related fields” said one student while another said “[The CAR Strategy] brings up an important issue that we should have been talking about a while ago.” It is worth noting, one student voiced that “hearing master-slave reminds me of sexual relationships more than historic racial situations.”

3.8 Discussion

Beginning with the quantitative data, the Likert-scaled survey results convey a telling story about students’ experiences with The CAR Strategy. The pre-CAR quantitative dataset alone provided insight into students’ initial reactions and feelings to potentially engaging in discussions on problematic engineering vernacular. The pre-CAR survey also gauged student sentiments prior to expo-

sure to The CAR Strategy. Overall, prior to exposure to The CAR Strategy, many students were open to confronting “master-slave” in a classroom setting.

Meanwhile, the post-CAR quantitative dataset alone yielded results on students’ perceptions of The CAR Strategy when applied to “master-slave” terminology. The post-CAR survey also provided a glimpse at The CAR Strategy’s potential future applications. Ultimately, the majority of students positively received the new pedagogy. We noticed that several students foresaw The CAR Strategy’s future application on engineering terminologies related to gender, with one student even foreseeing non-engineering applications of The CAR Strategy. For instance, The CAR Strategy could apply to pronouns in textbooks which use “he/him/his” as a default or standard and replace that with “they/them/theirs”.

Seven out of ten of the hypothesis tests achieved a rounded p-value of less than or equal to 0.05. Five out of the seven passing hypothesis tests achieved p-values less than or equal to 0.01. This shows the strong statistical efficacy of the novel CAR Strategy, which still has room for refinement as this is its first ever formal study.

With that said, two of the three unpassing hypothesis tests, D1 and D3 (p-values of 0.13 and 0.17, respectively) from Table 3.3, had low sample sizes of thirteen respondents. It remains unclear if these two p-values would be repeatable with a larger sample size. The same presumption applies to the passing hypothesis test of D2 (p-value of 0.03) Table 3.3 which also had a sample size of thirteen.

Furthermore, the qualitative data from both surveys strengthens the quantitative data. Although there were some dissenting opinions from the majority, it is clear that many engineering students are willing and capable of engaging in meaningful academic discourse. This is a notable observation because of the stigma

that engineering students do not value critical engagement of the technologies they work with or create [41].

The qualitative data from the pre-CAR survey is significant, because it confirms the demand among students for confronting, addressing, and replacing problems in educational institutions. The CAR Strategy is the supply to this demand. We found that some students even used the words confront, address, and replace in their open-ended responses prior to formal exposure to The CAR Strategy. It seems as though the new pedagogy is a natural progression and response for the engineering education field.

The qualitative data from the post-CAR survey is informative, because it helps provide direction for future research related to The CAR Strategy. A few students alluded to the gaps the pedagogy currently does not address such as “female-male” connectors and “blacklisting-whitelisting” in computer science element selection. One women-identifying student even admitted that “master-slave” makes them think about “sexual relationships.” These qualitative data points suggest The CAR Strategy should attempt to tackle the uncomfortable terminologies within engineering education as it pertains to gender. The quantitative data, supported by the qualitative data, warrants attention from engineering educators as a new framework for approaching problematic terminologies within curriculum.

For the few students who felt anthropomorphism has its place within engineering systems, recent psychological research suggests otherwise. Anthropomorphism in modern industrialized societies is “more cute than critical” and it contains “individual differences” which pose “consequences for everyday life” [42]. In fact, these consequences have implications on human-computer interaction and “inform classic issues underlying person perceptions” [42]. Anthropomorphism

may deserve its place within engineering lexicon, but the problem lies in the way in which systems are anthropomorphized to describe prejudicial relationships.

Lastly, it is relevant to mention this data collection occurred during Fall 2019. In May 2020, after the murders of George Floyd, Breonna Taylor, Ahmaud Arbery, and many others, America and the world witnessed a several-month long protest against outdated ideologies and social systems. Generational movements like these do not come out of nowhere. They typically are rooted in years or decades of microaggressions, macroaggressions, and stagnancy by people and institutions. Perhaps “master-slave” terminology was one of the many microaggressive forms of institutional racism which contributed to the historic wave of public protests.

The CAR Strategy is meant to be a proactive and modern pedagogy which encourages discussion and thought on whether or not we should replace questionable aspects within engineering. The CAR Strategy does not force students to replace “master-slave” or any terminology from their vernacular—it simply welcomes it.

With that said, the “replace” step of The CAR Strategy is the part which still requires refinement for “master-slave” and application to other terms. Both the quantitative and qualitative data suggest this critique. But it seems that this is because it is difficult to come to a consensus on replacement terminology. Until a study on a revised CAR Strategy is conducted, the researchers recommend leaving the replace step with room for debate. One way to go about replacing a terminology can be to conclude The CAR Strategy by administering a class vote on which terminology they democratically prefer. Even with a limited diversity student population like the one we had in this study, students seem ready for a shift within engineering and its advocacy for racial and gender equity.

3.9 Remarks

Ultimately, the data confirms The CAR Strategy is an effective pedagogy when applied to “master-slave” terminology. The majority of respondents agreed all three steps (Confront, Address, and Replace) were effective in their specific purposes when applied to “master-slave”. However, the Replace step warrants further research and improvement. The researchers thus consider The CAR Strategy a promising pedagogy worth further research applied to other potentially problematic terminologies in engineering education such as “female-male” (connectors) and “blacklist-whitelist” (element selection).

Chapter 4

OPTICAL CHARACTER RECOGNITION (OCR) TEST

4.1 Introduction

As an experiment to improve the replacement step of The CAR Strategy, I employ Optical Character Recognition (OCR) in MATLAB. Given data sheets and diagrams are where undergraduate engineering students reinforce usage of questionable jargon, it would be beneficial if there was a free software service which could automatically replace such jargon with a user's alternative of choice. The intention is not for instructors to "white-wash" datasheets before sending them to students. Rather, classes still would confront and address problematic terminology while the replacement could vary based on a user's alternative of choice.

Thus, the proposed solution to this problem is an OCR algorithm which can accurately detect instances of problematic terminology and then overlay them

with a more inclusive replacement terminology. The algorithm is developed with MATLAB’s built-in OCR capabilities as well as a custom-made OCR algorithm. Since MATLAB costs money, this algorithm cannot be considered free of cost. The OCR algorithm is tested on a 33-page Texas Instruments (TI) LM4308 datasheet which was last revised by TI in 2013 [9]. An LM4308 is a display interface CPU chip and a good example of the type of datasheet an engineering student would come across in their undergraduate studies. The datasheet has at least 100 instances of “master” and at least 115 instances “slave”.

Although most datasheets are accessible in PDF format, it is assumed all datasheet pages can convert into JPEG files, because MATLAB cannot process PDF files as images. Secondly, it is assumed all datasheet pages were not just low quality scans, but rather of the highest quality from the datasheet’s original authors. This experimentation does not focus on the PDF to JPEG conversion and vice versa, but rather only focuses on the OCR aspect of the solution.

Although the problem of text replacement has existed for decades, there is no widely available general solution to replace text within image-only PDFs due to the difficulty of accurately segmentation. One related Canadian study focused on character recognition for translation purposes, highlights this challenge by acknowledging, ”texts containing a lot of graphics, tables or floating footnotes... are among the types of texts which must undergo a semiautomatic pre-editing stage” [43]. One French publication discusses several ways OCR is being used to scan handwritten historical artifacts such as newspapers and legal documents as a way to enhance digital affordance for criminal justice history [44]. This is similar to how OCR could detect and replace occurrences of “Master” and “Slave” within outdated—but still relevant—technical documentation.

4.2 OCR Tested on "Master-Slave"

Testing the first page of the datasheet serves as a good way to train the algorithm, because it contains several instances of "master" and "slave". If the algorithm works on this page, then there is confidence it will work well on other datasheet pages. After reading in and thresholding the original page image to produce a binary image, the MATLAB `ocr()` function identifies and locates the text within the image. The `ocr()` function takes an image as its input and outputs an `ocrText` object which contains information about recognized text, text location, and the confidence of the recognition result.

Using the results of the `ocr()` function, `locateText()` is then used to locate the occurrences of "Master" and "Slave" (case insensitive) within the image. As an input, this function takes the words detected by the `ocr()` function and the words desired for detection, then outputs an object which contains the location of the located words (x,y coordinates, width, and height). After obtaining the locations of these specific terms, they are erased from the image by whiting out the locations where these terms occurred. Next, the alternative terms are resized to fit the whited-out space and then the replacement terms are stamped onto the document as shown in Fig. 4.1.

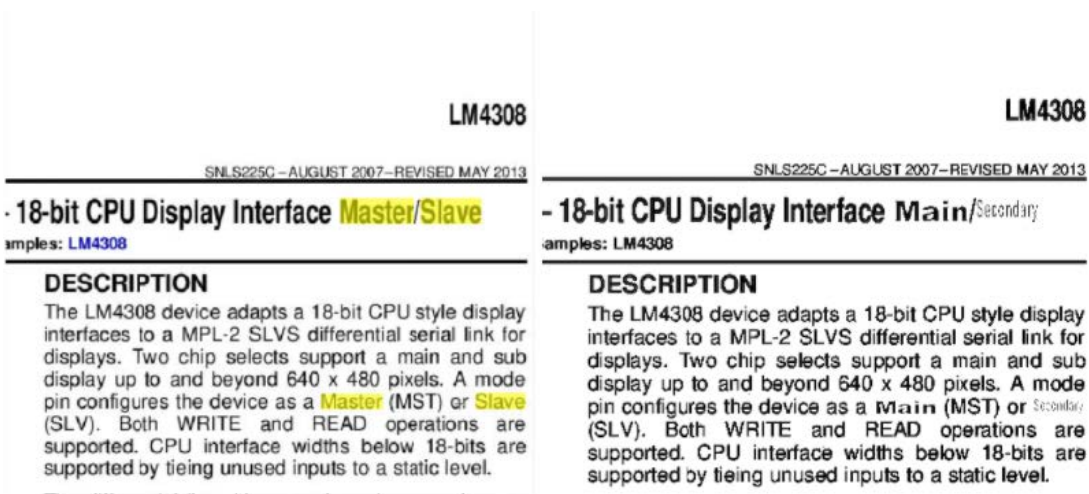

Figure 4.1: Initial implementation of OCR using MATLAB’s built-in `ocr()` function.

With this rudimentary solution, the next step is to theorize and experiment with different ways to improve improve initial results, because it is clear in Fig. 4.1 that the OCR implementation works well but is a little washed out, especially when replacing "Slave" with "Secondary". This warrants an attempt at implementing a custom OCR algorithm in MATLAB, specifically catered towards datasheets and recognizing problematic terms.

The development of a nonparametric and custom OCR algorithm starts with separating each line in an image and labeling the individual characters in the image. The alphabet in Fig. 4.2 serves as the image to train the line and character separation of the custom algorithm. Character separation is necessary to determine the characters’ order for word finding. To accomplish this first requires reading the alphabet image and converting it to a binary image. Then, a function similar to an open-source OCR function courtesy of a French engineering college [45] is enlisted to separate the lines in the alphabet image (see appended code in Section 6.2). Character separation uses MATLAB’s built-in `find()` function to

indicate the positions in the document where the sum of the columns in a row is equal to zero (see appended code in Section 6.3). Next, the binary image is sliced from the first pixel row to the next zero-sum row location and saved as one separated line of inverted text as shown in Fig. 4.3 (see appended code in Section 6.4).

**Aa Bb Cc Dd Ee
Ff Gg Hh Ii Jj Kk
Ll Mm Nn Oo Pp
Qq Rr Ss Tt Uu
Vv Ww Xx Yy Zz**

Figure 4.2: Training alphabet image of Arial font characters for the customized OCR algorithm.

Aa Bb Cc Dd Ee

Figure 4.3: The first line of Fig. 4.2 separated and inverted, using the customized OCR algorithm.

This type of line separation does an excellent job at separating sections of the document that are only text. However, it struggles in locations of the document where there are combinations of text and diagrams, or text in a table such as the examples in Fig. 4.4, Fig. 4.5, and Fig. 4.6. This is because the line separation algorithm depends on the presence of empty space between horizontal lines.

 Please be aware that an important notice concerning availability, standard warranty, and use in critical applications of Texas Instruments semiconductor products and disclaimers thereto appears at the end of this data sheet.

Figure 4.4: If there is a figure next to the text, the custom line separating code defines the height of the figure as the line height. So according to the custom OCR algorithm, it thinks this binary image is one line of text when it is actually two.

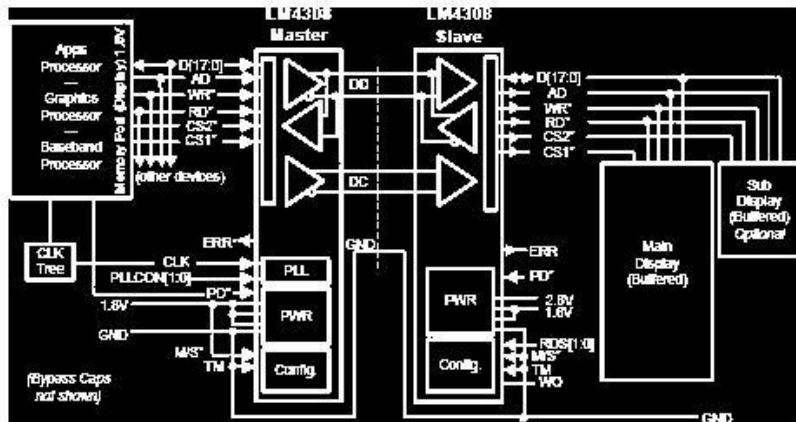

Figure 4.5: If there is text within a diagram, it cannot be separated and is all counted as one line of text. So according to the custom OCR algorithm, it thinks this image is one line of text when it is actually a complex drawing with many “lines” of independent text.

<ul style="list-style-type: none"> • Low Power Consumption • 5-bit CRC for Data Integrity • Level Translation between Host and Display 	<p>as common-mode, it is rejected by the receivers. This is further enhanced with the 50 Ohm output impedance of the drivers. The 100 Ohm termination is integrated into the receivers.</p>
---	---

Figure 4.6: The custom OCR algorithm also struggles when there are different font sizes on the same line, since one line in a larger font size can be equal to two lines in a smaller font size.

With these inaccuracies in mind, it is observed that each of the characters, otherwise known as connected pixels, within each line possess different properties that could be used as classifiers for the recognition algorithm. Problems arise when separating the characters by their connected pixels. This is because when looking at the number of connected pixels for the letters "j" and "i", there is pixel discontinuation in each character from the dot which is called the tittle. Issues also arise when there are two letters that visually touch each other such as in the case of double "t" where the horizontal portion of each "t" overlap. An example of this occurrence can be seen in Fig. 4.7 below.

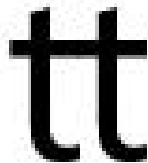

Figure 4.7: The custom OCR algorithm also struggles when there are different font sizes on the same line, since one line in a larger font size can be equal to two lines in a smaller font size.

This thesis does not dive into the pixel-level solutions for the overlapping letters and, thus, this challenge is declared a limitation to the algorithm. The issue of the tittles in the letters "i" and "j" can be solved using the same method

used to separate the lines on the horizontal axis to separate the lines vertically. After separating all characters, including their connected components, the `regionprops()` function can find different properties of each of the characters. An example of the `regionprops()` result of each of the characters in Fig. 4.3 is shown below in Fig. 4.8.

1	2		3			
Area	Centroid		BoundingBox			
37161	143.2444	161.2673	0.5000	3.5000	288	286
27036	403.7284	190.0504	302.5000	77.5000	194	217
47127	759.2629	147.8331	650.5000	3.5000	240	286
33369	1.0209e+03	166.8038	935.5000	3.5000	203	291
33527	1.3951e+03	147.5144	1.2835e+03	0.5000	249	294
22387	1.6569e+03	187.2105	1.5695e+03	77.5000	195	217
41485	2.0230e+03	146.2495	1.9145e+03	3.5000	240	287
33240	2.3071e+03	166.9629	2.1895e+03	3.5000	203	291
38933	2.6468e+03	145.8963	2.5575e+03	3.5000	217	286
26575	2.9008e+03	185.6763	2.8075e+03	77.5000	194	217

Figure 4.8: A table detailing the area, centroid, and bounding box coordinates for Fig. 4.3. Which is the first line of the Arial test image, Fig. 4.2. The ten rows of the table represent the ten characters in Fig. 4.2.

Using the area and bounding box size to classify every character in an image simply will not work due to scaling. Some text in an image may be a higher font size than others. Though a more consistent measurement that could be used would be the density of black to white pixels within the bounding box. This should be constant for all letters so long as they are not bold or italicized letters, since the density changes with these font adjustments. After comparing the density of multiple characters it can be seen that the densities of multiple characters are far too close for this classifier to be strong enough for use by itself.

Either a stronger classifier or adaptive boosting must strengthen the weak classifiers that `regionprops()` produces. Adaptive boosting, also known as

AdaBoost, is a "general method for improving the accuracy of of any given learning algorithm" [46]. While the density and centroid may have been too weak to use as identifiers, Hough Transforms may also classify well by finding the strong lines in each character to analyze the "stroke count". Hough Transformations detect lines and link edges in images through a parametric voting scheme [47].

4.3 Algorithm Analysis

Although the initial OCR solution implemented in Fig. 4.1 using MATLAB built-in functions was somewhat successful, there were clear areas for enhancement. One area for improvement is with non-horizontally aligned text. Another problem with the initial implementation was with the stamping of the replacement word. Although successful jargon location and whiting out of the jargon is achieved, stretching and fitting the replacement word often led to slightly distorted text such as squished or stretched letters. If the replacement word is significantly longer in length than the problematic word, then legibility of the replacement suffers.

Compared to the initial solution, the custom OCR implementation performed with similar results but with more true knowledge of the contents of the datasheet. The built-in OCR function obtained bounding boxes around the entire words "master" and "slave" but did not provide information on the contents of those bounding boxes, down to the letter. This is a potential limitation, because more data per word detection could make way for memory of past word detections which would train the algorithm better. Meanwhile, the custom OCR algorithm obtained information on every single character. However, it still did not accu-

rately separate lines of text which were next to or within figures. This is the main limitation of the algorithm, but it is fixable with further research and compute.

One way to continue improving this algorithm is preprocessing the datasheet so that its figures and diagrams no longer have continuous lines which throw off the line separating portions of the code. This would allow for detection and thus replacement of problematic terminologies.

One alternative approach to improve line separation is to remove any pixels that are not recognized as one of the letters in the test image of Fig. 4.2. This approach would strip down the datasheet page to only text and thus allow for the line separation function to work accurately for right side up text. But this method requires robust training sets, because it would miscategorize all untrained fonts and symbols.

Furthermore, there are sometimes lines of text, usually on diagrams, which are oriented sideways. To construct the most robust algorithm, it would make sense to build it to recognize when text is printed sideways. One way to accomplish this is to use a line separation function to check for pixel discontinuities row by row instead of column by column as done in Fig. 4.3. The challenge is instructing the algorithm when to separate vertical lines of text. To solve this, one could provide the algorithm with a sideways version of Fig. 4.2 and scan each page for vertical lines of text as well. This would likely add unnecessary computation time to the algorithm.

Moreover, to expand this project even more, training it with different fonts types and font sizes would suffice. This would make the algorithm even more robust so it can detect “master-slave” of any font and size.

Lastly, one way to make this algorithm truly customizable is by adding two parameters for users to select. The first parameter is the terminology the user wishes to replace and the second parameter is the replacement terminology the user wishes to use instead. This would allow users to choose other replacement terminologies for “master-slave.”

Additionally, users could replace other terms such as default pronouns in a textbook. This enhancement of the algorithm is possible, because the datasheet is separated character by character. But again, there are many variables such as font, size, and orientation at play which can affect the accuracy of such an algorithm.

4.4 Efficacy of OCR

In summary, the challenge of text recognition and replacement within documents is a complex issue with no clear cut solution, especially with edge cases. Despite the large market for PDF editing software, there is no free and efficient solution to conduct tasks such as detecting specific words in images and replacing them.

Finding the locations of the instances of “Master” and “Slave” within a document is fairly simple, but text replacement is much more challenging given the fixed space the replacement term has to fit in. The other major bottleneck is in the way the image is separated into lines of text. For the best results, the algorithm proposed in this thesis expects an image of just text. Pixels that may not be directly recognized as lines such as vertical text, images, and figures confuse the algorithm significantly.

This small-scale test ultimately implements a basic solution to this problem, but further refinement is required for public distribution of this implementation as a general solution/tool for manufacturers, educators, or students. The inaccessibility of image-only PDFs is a concrete manifestation of how technology (or lack thereof) enables systemic racism, and thus, is a barricade to systemic change.

Chapter 5

CONCLUSION

5.1 Final Presumptions

Engineering programs and post-secondary educational institutions in general must evolve to serve the desires of its students. The studies presented in this thesis produced data illustrating student sentiments of a novel engineering pedagogy rooted in antiracism. And the data concludes engineering educators can and should confront, address, and replace "master-slave" from curriculum.

5.2 Recommendations

Additional research is warranted on The CAR Strategy's efficacy on other potentially problematic terminologies in engineering education such as "female-male" (connectors), "blacklist-whitelist" (element selection), and "black hat-white hat" (hackers). With further research on larger and more diverse groups,

The CAR Strategy has promising applications in areas that transcend the lexicon of electrical engineering education.

APPENDIX

6.1 Additional Pre-CAR vs. Post-CAR Alluvial Diagrams

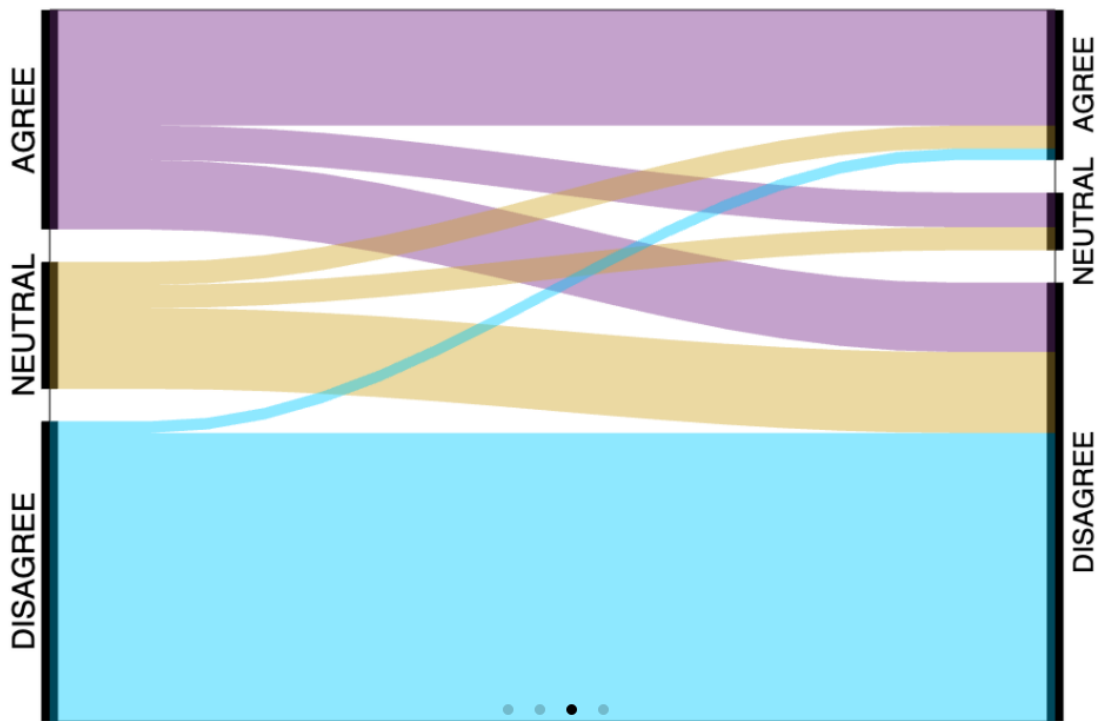

Figure 6.1: Survey responses for question B2² (n = 56), from Table 3.1, before and after The CAR Strategy.

²B2: I have never considered the impact “master-slave” terminology may have on others.

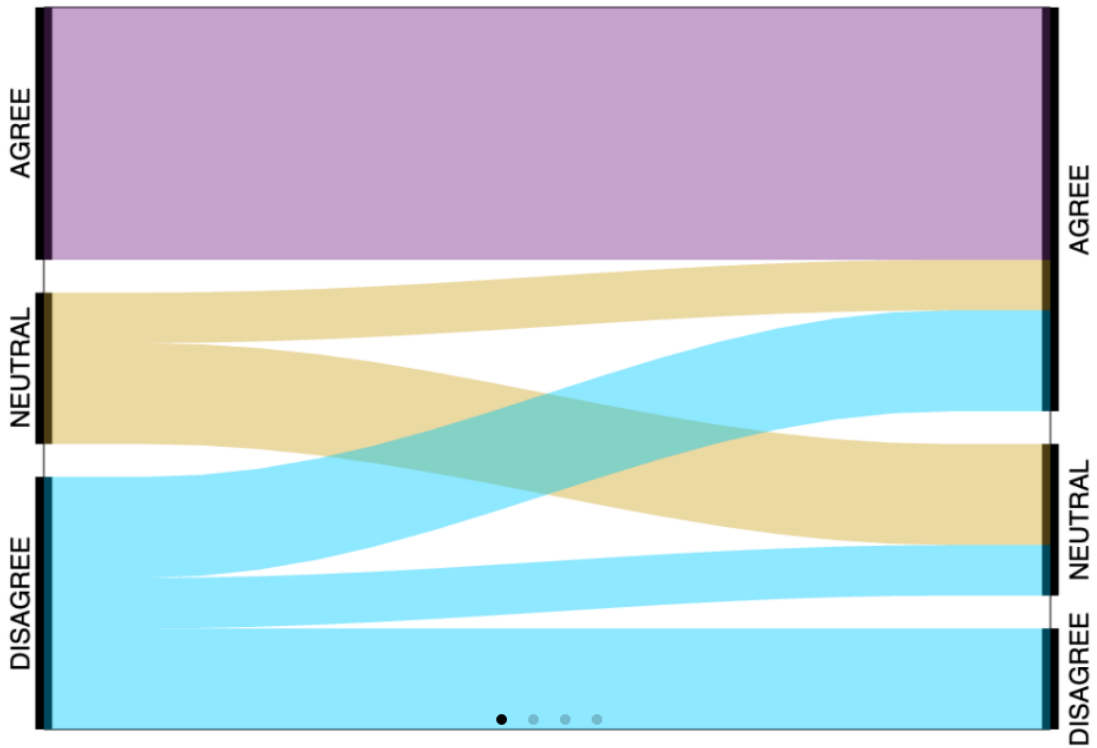

Figure 6.2: Survey responses for question D2⁴ (n = 13), from Table 3.2, before and after The CAR Strategy.

⁴D2: I would feel empathetic towards a classmate who finds this term problematic.

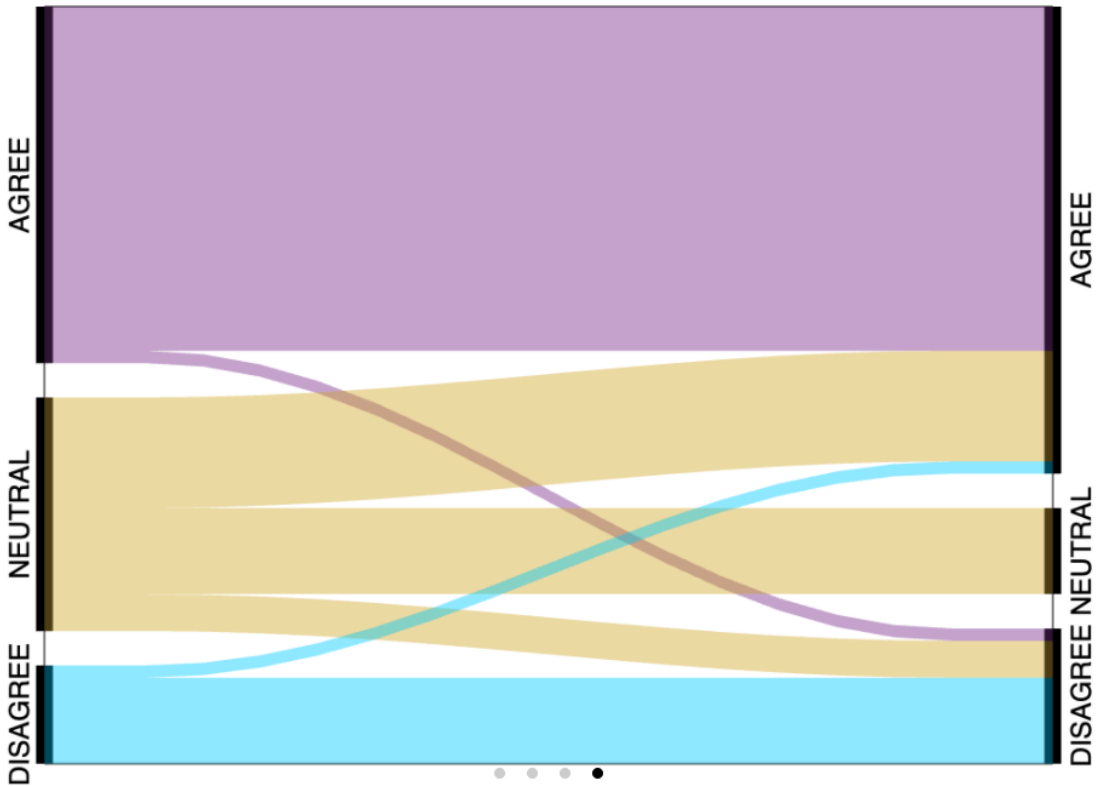

Figure 6.3: Survey responses for question E1⁶ (n = 56), from Table 3.4, before and after The CAR Strategy.

6.2 Custom Line Separation Function

```
% Code by Jamari Ducre, Amman Asfaw and Martin Jiang
% Function based on Martin Piegay's, OCR2.0
% Function to separate the input image into its
% separate lines, outputting first line & remaining lines.
function [first, rem] = separateLines(imageIn)
```

⁶E1: Professors should appropriately confront the historical significance and origins of “master-slave” terminology in courses that traditionally use the term.

```

% This is needed when reading left to right & top to bottom.

% Crop the image to remove white space
% around the borders of the image
imageIn = clip(imageIn);
rows_in_image=size(imageIn,1);

% Loop through each row of pixels in the image
% and add the separate line whenever there is
% a row of completely white space.
for s=1:rows_in_image
    if sum(imageIn(s,:))==0
        % First line matrix
        nm=imageIn(1:s-1, :);
        % Remain line matrix
        rm=imageIn(s:end, :);

        first=clip(nm);
        rem=clip(rm);
        break
    else
        % Only one line.
        first=imageIn;
        rem=[ ];
    end
end

```

6.3 Custom Character Separation Function

```
% Crops the image so there is no white  
% border surrounding the text  
function img_out = clip(img_in)  
[row, col] = find(img_in);  
img_out = img_in(min(row):max(row),min(col):max(col));  
end  
  
% Code by Jamari Ducre, Amman Asfaw and Martin Jiang  
% Function based on Martin Piegay's, OCR2.0  
% Function to separate the input image into its  
% separate lines, outputting first line & remaining characters.  
function [first, rem] = separateCharacters(imageIn)  
  
% This is needed when reading left to right & top to bottom.  
  
% Crop the image to remove white space  
% around the borders of the image  
imageIn = clip(imageIn);  
col_in_image=size(imageIn,2);  
  
% Loop through each column of pixels in the image  
% and add the separate character whenever there is  
% a column of completely white space.  
for s=1:col_in_image  
    if sum(imageIn(:,s))==0
```

```

        % First character matrix
        mm=imageIn(:, 1:s-1);
        % Remain character matrix
        rm=imageIn(:, s:end);

        first=clip(mm);
        rem=clip(rm);

        break
    else
        % Only one character.
        first=imageIn;
        rem=[ ];
    end
end
end

```

6.4 Custom OCR Code

```

% Code by Jamari Ducre, Amman Asfaw and Martin Jiang
% Custom OCR Algorithm
clear; close all; clc;

% Read the image and convert it to grayscale
im = imread('LM43081024_1.jpg');

% Convert to binary image

```

```

bw_image = rgb2gray(im);
thresh = 200;
bw_img = bw_image < thresh;

% Separate lines and obtain line properties
[first ,rem] = separateLines(bw_img);
group = bwconncomp(first);
props = regionprops('table',group,'BoundingBox',...
    'Area','Centroid');

% Iterate through entire image, separating lines
while size(rem,1) > 0
    [nextline ,rem] = separateLines(rem);
    figure;
    imshow(nextline);
    group = bwconncomp(nextline);
    next_props = regionprops('table',group,...
        'BoundingBox','Area','Centroid');
    props = [props;next_props];
end

[firstchar ,remchar]=separateCharacters(first);
imshow(firstchar);

```

Bibliography

- [1] Dr. Andrew Danowitz et al. “Assessing the Effects of Master-Slave Terminology on Inclusivity in Engineering Education”. In: *2020 CoNECD - The Collaborative Network for Engineering and Computing Diversity Conference*. CoNECD - The Collaborative Network for Engineering and Computing Diversity Conference. American Society of Engineering Education. URL: https://drive.google.com/file/d/1EtHzo-SYU1LX_hV-M5njnUWJRzcmNc6e/view?usp=sharing (visited on 06/16/2020).
- [2] Abdimalik Buul, Kisha Quesada Turner, and Ebony Tyree. “Curriculum Trauma”. In: *Academic Senate for California Community Colleges (ASCCC) Rostrum* (July 2020), pp. 59–63. URL: <https://indd.adobe.com/view/861210a6-c4e2-4715-b335-7fd34a456cb3> (visited on 07/13/2020).
- [3] Joseph Roy. *Engineering and Engineering Technology by the Numbers*. Washington D.C.: American Society for Engineering Education, 2019. URL: <https://ira.asee.org/wp-content/uploads/2021/02/Engineering-by-the-Numbers-FINAL-2021.pdf>.

- [4] *Women, Minorities, and Persons with Disabilities in Science and Engineering*. National Science Foundation, 2019. URL: <https://nces.nsf.gov/pubs/nsf19304/digest>.
- [5] Amman Fasil Asfaw et al. “Analysis of The CAR (Confront, Address, Replace) Strategy and its Efficacy when Applied to Master-Slave Terminology”. In: *2021 ASEE Annual Conference Proceedings*. 2021 American Society for Engineering Education Annual Conference and Exposition. American Society for Engineering Education, July 29, 2021.
- [6] Renée Ater. *Renée Ater: Public Scholar*. In Memoriam: I Can’t Breathe. Apr. 15, 2021. URL: <https://www.reneeater.com/on-monuments-blog/tag/list+of+unarmed+black+people+killed+by+police> (visited on 08/11/2021).
- [7] Colin M.L. Burnett. *SPI three slaves daisy chained*. Dec. 21, 2006. URL: https://commons.wikimedia.org/wiki/File:SPI_three_slaves_daisy_chained.svg.
- [8] *Master Cylinder Slave Cylinder Diagram*. Dec. 27, 2018. URL: <https://generaltransmissionreno.com/clutch-slave-cylinder-symptoms/master-cylinder-slave-cylinder-diagram/>.
- [9] *LM4308 Mobile Pixel Link Two (MPL-2) – 18-bit CPU Display Interface Master/Slave*. May 2013. URL: <https://www.digikey.com/htmldatasheets/production/2109173/0/0/1/lm4308.html>.
- [10] United States Department of Defense. *Unidentified*. Nov. 14, 2004. URL: <https://www.history.com/news/unidentified-ufo-investigation-documents>.

- [11] *Master Bedroom Plan*. URL: <https://www.pinterest.com/pin/637048309771728581/>.
- [12] *Amazon Basics High-Speed Male to Female HDMI Extension Cable - 3 Feet*. URL: <https://www.amazon.com/AmazonBasics-High-Speed-Female-Extension-Cable/dp/B01D5H8ZI8>.
- [13] *Solar Panel Connectors and Cables*. URL: <https://www.solar-electric.com/learning-center/how-to-use-mc4-connectors-cables.html/>.
- [14] *USB Cable - 1X5 Female to 1x5 Male*. URL: <https://www.frontx.com/cpx512.html>.
- [15] *U-229 Connector: US Army and NATO standard audio and FILL connector*. Dec. 20, 2011. URL: <https://www.cryptomuseum.com/crypto/usa/u229/index.htm>.
- [16] *Blacklisting vs. Whitelisting*. Aug. 12, 2019. URL: <https://consoltech.com/blog/blacklisting-vs-whitelisting/>.
- [17] *Types of Hackers: The Hats They Wear and What They Do*. 2021. URL: <https://online.maryville.edu/blog/types-of-hackers/>.
- [18] Amman Asfaw. *The CAR Strategy (Confront Address Replace) for Master-Slave Terminology in STEM Education*. San Luis Obispo, Apr. 24, 2020. URL: https://www.youtube.com/watch?v=_tIMFS0Cpo (visited on 04/24/2020).
- [19] Daniel Solorzano, Miguel Ceja, and Tara Yosso. "Critical Race Theory, Racial Microaggressions, and Campus Racial Climate: The Experiences of African American College Students". In: *The Journal of Negro Education* 69.1 (2000). Publisher: Journal of Negro Education, pp. 60–73. ISSN:

- 00222984, 21676437. URL: <http://www.jstor.org.ezproxy.lib.calpoly.edu/stable/2696265> (visited on 05/20/2021).
- [20] “United States Census Bureau QuickFacts”. Statistics Presentation. Statistics Presentation. United States, July 1, 2019. URL: <https://www.census.gov/quickfacts/fact/table/US/PST045219> (visited on 08/16/2020).
- [21] Terrell L. Strayhorn, James M. DeVita, and Amanda M. Blakewood. “Broadening participation among women and racial/ethnic minorities in science, technology, engineering and maths”. In: *Social inclusion and higher education*. 1st ed. Bristol University Press, Policy Press, 2012, pp. 65–82. URL: <https://www-jstor-org.ezproxy.lib.calpoly.edu/stable/j.ctt1t891n1.8> (visited on 08/16/2020).
- [22] *Minority Serving Institutions: America’s Underutilized Resource for Strengthening the STEM Workforce*. The National Academic Press, 2019, pp. 23–38. URL: <https://www.nap.edu/read/25257/chapter/4>.
- [23] Marieke Meeuwisse, Sabine E. Severiens, and Marise Ph. Born. “Learning Environment, Interaction, Sense of Belonging and Study Success in Ethnically Diverse Student Groups”. In: *Research in Higher Education* 51.6 (Sept. 2010), pp. 528–545. URL: <https://www-jstor-org.ezproxy.lib.calpoly.edu/stable/40785093> (visited on 08/16/2020).
- [24] Suzanne Brahmia and Eugenia Etkina. “Emphasizing the Social Aspects of Learning to Foster Success of Students at Risk”. In: Physics Education Research Conference: Research at the Interface. Rochester, New York. URL: file:///Users/Amman/Downloads/PERC01_Invited_Etkenia.pdf.

- [25] Mallory Knodel and Niels ten Oever. *Terminology, Power and Oppressive Language*. Oct. 22, 2018. URL: <https://tools.ietf.org/id/draft-knodel-terminology-00.html> (visited on 07/07/2020).
- [26] Ron Eglash. “Broken Metaphor: The Master-Slave Analogy in Technical Literature”. In: *Technology and Culture* 48.2 (Apr. 2007), pp. 360–369. URL: <https://www-jstor-org.ezproxy.lib.calpoly.edu/stable/40061475> (visited on 07/28/2020).
- [27] Xiaoyu Su. “Master–Slave Control for Active Suspension Systems With Hydraulic Actuator Dynamics”. In: *IEEE Access* 5 (2017), pp. 3612–3621. ISSN: 2169-3536. DOI: 10.1109/ACCESS.2017.2672598. URL: <https://ieeexplore.ieee.org/abstract/document/7874115/authors#authors> (visited on 09/08/2020).
- [28] Rayan Mohamed Hamid and Eltahir Mohamed Hussein. “Microcontroller Based Master Slave Communication for Electrical Stepper Motor”. In: *International Journal of Science and Research (IJSR)* 5.5 (2016), pp. 2153–2156. ISSN: 2319-7064. URL: <https://pdfs.semanticscholar.org/02b5/bc84a570ba0af6584cb875cdeb35f2847936.pdf> (visited on 09/08/2020).
- [29] Casey B. *Consider renaming master branch to something less offensive*. ContributorCovenant. Sept. 9, 2018. URL: https://github.com/ContributorCovenant/contributor_covenant/issues/569.
- [30] *Ballistic Missile Defense Glossary*. June 1997. URL: <https://www.globalsecurity.org/military/intro/reference/glossary.pdf>.

- [31] Nikolay Baychenko. “Implementing a Master/Slave Architecture for a Data Synchronization Service”. PhD thesis. Finland: Turku University of Applied Sciences, 2018. 34 pp. URL: https://www.theseus.fi/bitstream/handle/10024/143791/Nikolay_Baychenko.pdf?isAllowed=y&sequence=1.
- [32] *Master Bedroom and Bathroom Terminology*. Real Estate Standards Organization (RESO Discussion). June 17, 2020. URL: <https://www.reso.org/master-bed-and-bath-terminology/>.
- [33] Frank Houghton and Sharon Houghton. “Blacklists’ and ‘whitelists’: a salutary warning concerning the prevalence of racist language in discussions of predatory publishing”. In: *Journal of the Medical Library Association: JMLA* 106.4 (Oct. 1, 2018), p. 527. DOI: [10.5195/jmla.2018.490](https://doi.org/10.5195/jmla.2018.490). URL: <https://www.ncbi.nlm.nih.gov/pmc/articles/PMC6148600/>.
- [34] Elana Lyn Gross. “Twitter And JPMorgan Chase Are The Latest Companies To Remove Terms ‘Master’ And ‘Slave’ From Programming Code”. In: *Forbes.com* (July 3, 2020). URL: <https://www.forbes.com/sites/elanagross/2020/07/03/twitter-and-jpmorgan-chase-are-the-latest-companies-to-remove-terms-master-and-slave-from-programming-code/?sh=de9b2383cedd>.
- [35] Jane G. Stout and Nilanjana Dasgupta. “When He Doesn’t Mean You: Gender-Exclusive Language as Ostracism”. In: *Personality and Social Psychology Bulletin* 37.6 (2011), pp. 757–769. URL: <https://gap.hks.harvard.edu/when-he-doesn%E2%80%99t-mean-you-gender-exclusive-language-ostracism>.

- [36] Dawn R. Johnson. “Women of Color in Science, Technology, Engineering, and Mathematics (STEM)”. In: *NEW DIRECTIONS FOR INSTITUTIONAL RESEARCH*. 152. Wiley Periodicals, Inc., 2011. URL: <https://eric.ed.gov/?id=EJ957421>.
- [37] Rensis Likert. “A technique for the measurement of attitudes”. In: *Archives of Psychology* 20.140 (1932), p. 55.
- [38] *Paired t-test*. Jan. 6, 2016. URL: <https://sphweb.bumc.bu.edu/otlt/MPH-Modules/BS/SAS/SAS4-OneSampleTtest/SAS4-OneSampleTtest7.html#:~:text=A%20paired%20t%2Dtest%20is,variables%20are%20separated%20by%20time.&text=Since%20we%20are%20ultimately%20concerned,the%20one%20sample%20t%2Dtest> (visited on 10/07/2020).
- [39] Andy Wai Kan Yeung. “Data Visualization by Alluvial Diagrams for Bibliometric Reports, Systematic Reviews and Meta-Analyses”. In: *Current Science* 115.10 (Nov. 2018), pp. 1942–1947. DOI: [10.18520/cs/v115/i10/1942-1947](https://doi.org/10.18520/cs/v115/i10/1942-1947). URL: https://www.researchgate.net/publication/329377404_Data_Visualization_by_Alluvial_Diagrams_for_Bibliometric_Reports_Systematic_Reviews_and_Meta-Analyses.
- [40] Catherine Allen. “Cal Poly Is The Only Predominantly White CSU. Here’s Why”. In: *Mustang News* (May 21, 2021). URL: <https://mustangnews.net/cal-poly-is-the-only-predominantly-white-csu-heres-why/>.
- [41] Erin A. Cech. “Culture of Disengagement in Engineering Education?” In: *Science, Technology, & Human Values* 39.1 (Jan. 1, 2014), pp. 42–72.

URL: <https://doi.org/10.1177/0162243913504305> (visited on 02/28/2021).

- [42] Adam Waytz, John Cacioppo, and Nicholas Epley. “Who Sees Human? The Stability and Importance of Individual Differences in Anthropomorphism”. In: *Perspectives on Psychological Science* 5.3 (May 2010), pp. 219–232. URL: <https://www.jstor.org/stable/41613332>.
- [43] Elliott Macklovitch and Marie-Louise Hannan. “Line ‘Em Up: Advances in Alignment Technology and their Impact on Translation Support Tools”. In: *Machine Translation* 13 (1998), pp. 41–57. DOI: <https://doi-org.ezproxy.lib.calpoly.edu/10.1023/A:1008066404387>. URL: <https://www.aclweb.org/anthology/1996.amta-1.15.pdf>.
- [44] Tim Hitchcock. “Digital Affordances for Criminal Justice History”. In: *Crime, Histoire & Sociétés / Crime, History & Societies* 21.2 (2017), pp. 335–342. DOI: <https://doi.org/10.4000/chs.2016>. URL: <http://journals.openedition.org/chs/2016>.
- [45] Martin Piegay. *Optical Character Recognition 2.0 (OCR 2.0)*. MATLAB Central File Exchange. Feb. 25, 2013. URL: <https://www.mathworks.com/matlabcentral/fileexchange/40499-optical-character-recognition-2-0-ocr-2-0>.
- [46] Yoav Freund and Robert E. Schapire. “A Short Introduction to Boosting”. In: *Journal of Japanese Society for Artificial Intelligence* 14.5 (Sept. 1999), pp. 771–780. URL: <https://cseweb.ucsd.edu/~yfreund/papers/IntroToBoosting.pdf>.
- [47] Richard O. Duda and Peter E. Hart. “Use of the Hough Transformation to Detect Lines and Curves in Pictures”. In: *Communications of the Associa-*

tion for Computing Machinery 15.1 (Jan. 1972), pp. 11–15. URL: <https://www.cse.unr.edu/~bebis/CS474/Handouts/HoughTransformPaper.pdf>.