

SAVER

(Surface Autonomous Vehicle for Emergency Rescue)

Mechatronics Team - Final Design Report

June 3, 2021

Sponsor(s): NASA Micro-g NExT
Mechanical Engineering Department
California Polytechnic State University,
San Luis Obispo

Team(s): Cal Poly SAVER 2 – Mechatronics Team
Ethan Miller
Josephine Isaacson
Tyler Jorgensen
Joshua Hoye

Advisor: Sarah Harding

Statement of Disclaimer

Since this project is a result of a class assignment, it has been graded and accepted as fulfillment of the course requirements. Acceptance does not imply technical accuracy or reliability. Any use of information in this report is done at the risk of the user. These risks may include catastrophic failure of the device or infringement of patent or copyright laws. California Polytechnic State University at San Luis Obispo and its staff cannot be held liable for any use or misuse of the project.

Abstract

This document serves to introduce the design team and their competition challenge, as well as to detail the results of the project. The original design challenge was the NASA Micro-g NExT's SAVER (Surface Autonomous Vehicle for Emergency Rescue) competition; we were tasked with developing a self-driving water vehicle capable of delivering supplies to Orion astronauts separated from the rest of their crew in the case of a maritime emergency. However, we were not selected to go forward in this competition and thus we decided to scale down the size of the SAVER device to shift the focus of the project to testing and refining the technologies necessary for a successful future team. Additionally, our overall Cal Poly SAVER design team was split into two subsystems: one focused on the hull and payload of SAVER and the other focused on the navigation, controls, and mechatronic components. This report will detail the design process of the navigation and controls subsystem. Throughout the course of the project, we performed research on the problem at hand, outlined and refined a preliminary design through ideation and initial analysis. Following the downsizing of the project, we finalized the design, created prototype devices, and performed testing on these devices. The main body of this report details our design processes, as well as the manufacturing, testing, and verification of the SAVER navigation and controls prototype. Finally, a project management section describes our plans for handing off the current SAVER device and documentation to next year's SAVER team.

Table of Contents

Statement of Disclaimer	i
Abstract.....	ii
List of Figures.....	vi
List of Tables	vii
1 – Introduction.....	1
2 – Background	2
2.1 – Competition Prompt and Info Sessions.....	2
2.2 – Existing Products and Procedures.....	2
2.2.1 – Products.....	2
2.2.2 – Patents.....	5
2.3 – Standards and Regulations.....	6
2.4 – Technical Research	6
3 – Objectives.....	10
3.1 – Problem Statement.....	10
3.2 – Boundary Diagram.....	10
3.3 – Quality Function Deployment.....	11
4 – Concept Design.....	15
4.1 – Ideation.....	15
4.2 – Concept Selection	16
4.3 – Design Direction	17
4.3.1 – Manufacturing.....	19
4.3.2 – Mechatronics	19
4.4 – Preliminary Analysis.....	21
4.5 – Risks, Challenges, and Unknowns	21
5 – Final Design	24
5.1 – Radio Direction Finding.....	25
5.2 – Close Range Navigation	29
5.3 – Propulsion and Power	31
5.4 – Stages of Operation	33
6 – Manufacturing.....	35
6.1 – Electronics.....	37

6.2 – Manufacturing Update	38
6.3 – Bow Box.....	38
6.4 – Internal Dry Box.....	39
6.5 – Propulsion	40
6.6 – Maintenance and Repair	40
6.7 – Safety	40
6.8– Cost.....	41
7 – Design Verification.....	42
7.1 Bearing System	42
7.1.2 – Direction Finding.....	42
7.1.2 – Positioning System	44
7.1.3 – Triangulation	45
7.2 – Visual System.....	46
7.2.1 – Object Detection	46
7.2.2 – Depth Mapping.....	48
8 – Project Management.....	50
8.1 – Overview	50
8.2 – Testing	50
8.3 – Future of the Project	50
9 – Conclusions and Recommendations.....	51
9.1 – Recommendation for Direction Finding	51
9.2 – Recommendation for Proximity Detection	52
Works Cited.....	53
Appendix A: QFD House of Quality	A1
Appendix B: Weighted Decision Matrix.....	B1
Appendix C: Preliminary analysis	C1
Appendix D: Drawing Package and Specifications Sheets.....	D1
Appendix E: Fully Annotated Code	E1
Appendix F: SAVER: Navigation and Controls Project Budget.....	F1
Appendix G: Failure Modes and Effects Analysis (FMEA).....	G1
Appendix H: Design Hazard Checklist.....	H1
Appendix I: Risk Assessment.....	I1

Appendix J: User Manual	J1
Appendix K: Design Verification Plan.....	K1
Appendix L: Testing Procedures	L1
Appendix M: Gantt Chart.....	M1

List of Figures

Figure 2.1: U.S. Navy’s Blackfish Prototype	3
Figure 2.2: Hydronalix’s EMILY Device	4
Figure 2.3: NASA’s ANGEL Beacon.....	7
Figure 2.4: Correlative Interferometer	8
Figure 2.5: Global Foundation of Ocean Exploration’s Deep Discoverer.....	9
Figure 3.1: SAVER Boundary Diagram	10
Figure 4.1: SAVER Function Tree	15
Figure 4.2: Final Design Sketch.....	18
Figure 4.3: Final Design Preliminary CAD Model.....	18
Figure 4.4: Watson-Watt System	20
Figure 5.1: Final SAVER CAD Model.....	25
Figure 5.2: Antenna Receiver Phase Diagram.....	26
Figure 5.3: KerberosSDR Module for Direction Finding	27
Figure 5.4: External Antenna Housing CAD Model.....	28
Figure 5.5: NVIDIA Jetson Image Recognition	30
Figure 5.6: Stereo Camera System for NVIDIA Jetson.....	30
Figure 5.7: Chosen Thruster for SAVER.....	32
Figure 5.8: Overall SAVER electronics Schematic.....	32
Figure 5.9: SAVER Triangulation Simulation.....	33
Figure 7.1: KerberosSDR Software Bearing Output.....	43
Figure 7.2: GPS Module Accuracy Comparison.....	44
Figure 7.3: KerberosSDR Mapping Software Output.....	45
Figure 7.4: Object Detection Confidence/Consistency Plot.....	47
Figure 7.5: Stereo Camera Output.....	48

List of Tables

Table 2.1: Additional Relevant Products List.....	4
Table 2.2: Relevant Patents List	5
Table 3.1: Engineering Specifications Table.....	13
Table 4.1: Morphological Matrix.....	16
Table: 6.1: Mechatronics Team Manufacturing Plan.....	36
Table: 7.1: Object Detection Raw Data.....	46

1 – Introduction

This project team consisted of four senior mechanical engineering students at California Polytechnic State University, San Luis Obispo: Joshua Hoye, Josephine Isaacson, Tyler Jorgensen, and Ethan Miller. Our faculty advisor for this project is mechanical engineering professor Sarah Harding. We originally planned to design an autonomous watercraft for the 2021 NASA Micro-g NExT SAVER (Surface Autonomous Vehicle for Emergency Rescue) competition. For this design challenge, NASA Micro-g NExT and the Orion crew need a vehicle capable of autonomously delivering supplies to a stranded astronaut during a maritime emergency. In addition to us, three other Cal Poly students (Holly Johnson, Adam Swarthout, and Zachary Rannalli) made up the manufacturing team for SAVER.

However, we were not selected to move forward in the competition, and thus we decided to scale down the vehicle to half of the originally intended size in order to save costs and reduce the overall complexity of the design. Rather than focus on making this half-scale model fulfill every aspect of the competition's scope, we instead prioritized creating a proof-of-concept device and laying the groundwork for future Cal Poly teams to succeed going forward.

This report details the scope of the project, explains the final design decision-making process, overviews the manufacturing, assembly, and testing carried out by us, and outlines our plans for carrying on the project into the future. Overall, it will serve to present a detailed description of our design, as well as the challenges overcome, and knowledge gained throughout the project.

2 – Background

This section will detail the background research completed and its relevance to our design challenge, as well as detail how the scope of the project changed following the choice to downscale SAVER. The specifics of the competition will be highlighted, similar existing solutions will be described, and the regulations surrounding waterborne vehicles will be identified. Finally, technical research surrounding the navigation and propulsion systems of SAVER will be described in detail.

2.1 – Competition Prompt and Info Sessions

The foundation for this project comes from the detailed description of the design challenge set forth by NASA’s Micro-G NEXT program. As a part of NASA’s Artemis program, crewed launches will be increasing in efforts to return to the moon by 2024. With increased quantity of missions comes a greater risk of unplanned complications during water landings. Generally, the Orion capsule deploys a life raft for the crew to await the search and rescue (SAR) team; in this situation, there is a cause for concern that one of the members of the crew may become separated from the main life raft. NASA needs a way to rapidly tend to the immediate needs of an isolated crew member without diverting manpower from the main rescue party; therefore, NASA is requesting that university teams “design a surface vehicle capable of assisting astronauts in distress in a maritime environment, through the location and delivery of crew survival aids” (“Micro-g NEXT 2021 Design Challenges”).

2.2 – Existing Products and Procedures

This section details our research findings related to current products that fulfill similar roles as SAVER as well as the different methods these products use to accomplish their objectives.

2.2.1 – Products

The hope for this project was to create a device that could act as a force-multiplier and to allow the SAR team to respond as rapidly as possible. With that in mind, we considered existing products and procedures. Unmanned aerial and marine vessel designs have been pushed forward

for military and research purposes, following set paths to collect data, survey regions, or protect from aquatic assaults. Investigating these technologies allows us to create a more robust design by building on top of ideas that have already been proven effective or otherwise tested.

The US Navy developed a product similar in capability to SAVER for harbor defense called the “Blackfish,” seen in Figure 2.1. This device has been deployed to scout abnormalities in sonar readings rather than spreading resources thin by deploying a unit of soldiers (Hambling). It is essentially a remote-controlled jet ski with additional off-the-shelf hardware. Because jet ski propulsion does not allow for the vehicle to maneuver easily at low speeds, the design also incorporates bow thrusters.



Figure 2.1. US Navy’s prototype for Blackfish, a harbor defense device used to scout and potentially eliminate abnormalities in sonar scanning (Hambling).

Although Blackfish’s primary purpose is to detect and eliminate potential threats to harbor safety, products such as Hydronalix’s Emergency Integrated Lifesaving Lanyard (EMILY), seen in Figure 2.2, shares with SAVER the goal of deploying safety equipment to victims in distress. EMILY is a remote-control safety device used by lifeguards to reach victims in poor conditions without risk to themselves. After successfully reaching the victim, the device will deploy a life jacket and recovery line, much like SAVER’s need to deploy the specific safety equipment after reaching stranded astronauts (EMILY). Some other products that relate to SAVER’s functions may be found in Table 2.1.



Made in the U.S.A.
 U.S. Patent 8,882,555
 Korean Patent 10-1482486

Figure 2.2. EMILY remote-control rescue device by Hydronalix (EMILY).

Table 2.1. List of additional relevant products.

Product Name	Company	Description	Citation
Deep Discoverer	Global Foundation for Ocean Exploration	Remotely operated vehicle used for deep ocean exploration. Remotely controlled by personnel on mothership using joystick. Comprised of many sensors for research of deep ocean environments.	(“ROV Deep Discoverer”)
Free-Fall Lifeboat	Survitec	Manned vehicle designed to withstand being dropped from a significant height. Vessel contains a single propeller in the rear, and the mass distribution allows for it to self-right itself.	(Survitec)
Navy Sea Hunter	Vigor Industrial	Autonomous unmanned surface vehicle launched used for anti-submarine warfare. Uses path finding and tracking control systems to sweep for submarines.	(Njus)

There were some important lessons to be learned from all these products; They all provided examples of hull shape, propulsion systems, and steering systems. Many also provided examples of hardware and sensors to support the navigation systems. Another interesting feature that was not consistent across the board was aesthetics; SAR applications tend to utilize bright, noticeable colors, while military applications tend to use cold colors.

In addition to the physical properties of the boat, there are products that provide insight into the identification and navigation aspects of SAR. The aeronautical industry has accelerated the need of autonomous distress tracking (ADT) since the 2014 Malaysia Airlines Flight 370 disappearance, whose search operation summed to \$150 million. ADT technology allows the locating of distress signals long before deployment of human-led SAR efforts. SAVER could utilize ADT control systems like that of Blue Sky Network’s Hawkeye with reduced range and increased speed as a baseline for its autonomous action (Aerospace Testing International).

2.2.2 – Patents

Research into existing patents also proved to be beneficial to our understanding of existing technology. These patents as well as descriptions of them are included in Table 2.2.

Table 2.2. List of relevant patents.

Number	Name	Company/Designer	Key Characteristics	Citation
US7948439 B2	Tracking of autonomous systems	David C. Baughman (Honeywell International Inc.)	A two-beacon setup transmits successive signals that can be tracked by portable tracking systems.	(Baughman)
JP20185144 33A	水環境移動ロボット (Water environment mobile robot)	<u>アリ・オータ</u> <u>ファドウル・アブデルラ</u> <u>ティフ</u>	A water environment robot system includes a control station, an underwater robot vehicle, and water surface robot vehicle.	(Ari et al.)
US6269763 B1	Autonomous marine vehicle	Richard L. K. Woodland	An autonomous marine vehicle is comprised of a rigid hull capable of heavy-duty applications. It uses various sensors and hardware to move autonomously.	(Woodland)
US6558218 B1	Overboard rescue system	Eric C. Hansen (US Secretary of Navy)	A self-powered propulsion service vehicle delivers floatation devices to distress locations of overboard personnel.	(Hansen)
US2018008 2166A1	System and Method for Autonomous Tracking and Imaging of a Target	Amy L. Kukulya, Thomas Austin, Frederic Jaffre (Woods Hole Oceanographic Institute WHOI)	A submersible device is used to autonomously tag and track targets in a liquid medium.	(Kukulya et al.)
GB1904131 70A	Hertzian-Wave Projecting and Receiving Apparatus Adapted to Indicate or Give Warning of the Presence of a Metallic Body, such as a Ship or a Train, in the Line of Projection of such Waves	Christian Huelsmeyer	A transmitter releases waves, which bounce back and are detected by a receiver. This system detects the direction of a metallic body relative to the device.	<i>(Hertzian-Wave Projecting and Receiving Apparatus)</i>
GB1904256 08A	Improvement in Hertzian-Wave Projecting and Receiving Apparatus for Locating the Position of Distant Metal Objects	Christian Huelsmeyer	This system detects the proximity of a metallic body relative to the device by comparing signal intensity.	<i>(Improvement in Hertzian-Wave Projecting and Receiving Apparatus)</i>

Many of the patents researched were directed toward the autonomous feature of the marine vehicle, and thus described how an autonomous system works and the principles of path-following capabilities and motion-controlling systems. That said, many lacked the direction-finding capabilities needed for SAVER to fulfill its navigation functions. Early radar technology provided a base understanding of the principles of location-finding, and further research allowed for a better understanding of how to refine precision and filter noise.

2.3 – Standards and Regulations

Autonomous marine vehicles (AMVs) have legal ambiguity when assessing risks and liabilities. All marine surface vehicles follow the International Regulations for Preventing Collisions at Sea (COLREGs) set forth by the International Maritime Organization (IMO). These regulations include rules for steering, lights, sounds, and most importantly, traffic (COLREG). It is easy to assume that AMVs need to follow these regulations, but the definition of AMVs results in legal ambiguity. The legal status of AMVs is explored in a Case Western Reserve Journal of International Law report. The report claims that a large obstacle AMVs face in discerning lawful operation is their sizing (Vallejo). Captain Marc Deglinnocenti of the US Coast Guard has been seeking regulations that apply to AMVs. Deglinnocenti outlines rules within COLREGs that exempt devices under 7 meters in length from normal vessel regulations (Deglinnocenti). Due to the size restrictions set by NASA, SAVER will not come near to this length, thus bypassing specific COLREGs that might complicate the system.

2.4 – Technical Research

Due to the specificity of SAVER's purpose, a multitude of technical constraints and opportunities had to be considered before effective design could begin – some of which were prescribed by the competition host, and others which arose from analysis of the current situation.

According to the project specifications, each astronaut was to be equipped with NASA's personal locator beacon (PLB), nicknamed "ANGEL" (Jenner). This beacon transmits GPS location data on the international distress frequency band of 406 MHz, which is then relayed to a mission control center who determines an appropriate response. More importantly for SAVER's design, ANGEL produces a 121.5 MHz homing frequency. Once dropped from the UAV, SAVER will use direction-finding technology to detect the homing frequency and calculate a bearing

towards the beacon (“Micro-g NExT 2021 Design Challenges.”). There are a variety of technologies that are used for direction-finding, such as correlative interferometry, dual-dipole antenna systems, loop antenna systems, and Doppler.



Figure 2.3. NASA’s personal locator beacon, ANGEL (Mazzuca).

A correlative interferometer uses an antenna system to detect the phase change of an incoming radio signal. These signals are then compared to a theoretical set of phase changes captured in the calibration of the device when no radio wave emitters are present. The difference between these two sets of data result in a sequence of correlation coefficients. The largest coefficient indicates the direction of the emitter. For example, if the correlative interferometer in Figure 2.4 were in use and the emitter was south of the interferometer, the bottom antenna would have the largest correlation coefficient. The active range that these devices detect are usually between 0.1 to 300 GHz (Shi). This range would prove to be problematic for SAVER because the 121.5 MHz homing signal does not fall within that range.

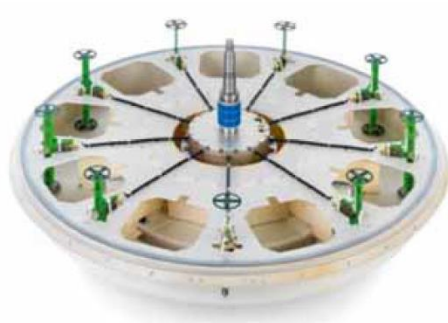

Figure 2.4. Correlative interferometer used for direction-finding (Shi).

Doppler direction-finding analyzes the doppler shift of a signal sampled by a spinning antenna. The operation of spinning an antenna and collecting data from it is cumbersome and difficult to achieve, so pseudo-Doppler analysis was created. Pseudo-Doppler analysis uses a static array of antennae and switches between them in rapid succession. By measuring the signal at each point, the system can produce similar results to the physically spinning system. These devices must be large in order to measure a reasonable doppler shift (Rudersdorfer). This size could mean this option is not viable for SAVER.

A simple dual-dipole direction-finding system can be employed to determine orientation relative to the signal and thus guide location and path finding, as demonstrated by Braden Huber in his BYU master's thesis (Huber). These devices find the vector difference between two sets of orthogonal antennae. The antenna pairs capture the signal, and a micro-controller or other computer system compares the characteristics of the signal such as phase, amplitude, or frequency. An example of these technologies is the Watson-Watt technique, which compares the amplitudes of the signals (Rudersdorfer).

Researching related products and patents uncovered a myriad of viable propulsion systems that could be used for SAVER. The Navy's Blackfish design uses a jet ski motor system that produces high speeds but has limits in its control scheme and maneuverability (Hambling). The Hydronolix EMILY utilizes a similar jet ski propulsion system, which minimizes risk of harm to victims since the impellor is hidden inside the hull (EMILY). Another viable option is using caged propellers, which are used most-commonly by research vessels like the Deep Discover from the Global Foundation of Ocean Exploration in Figure 2.5 (US Department of Commerce). The best design direction for the propulsion system will be further explored during the ideation and decision processes for SAVER.



Figure 2.5. Deep Discover by the Global Foundation of Ocean Exploration, with caged propellers on the bottom of the device (US Department of Commerce).

Since this project was originally designed to create a proof of concept in a competition, NASA had certain given certain specifications which may not necessarily reflect its real-world application. One such feature is the power source requirement; SAVER could utilize onboard power or compressed gas and must instead use a 12V DC 25A power outlet via an umbilical tether (“NBL Engineering and Safety Requirements for Micro-g NExT”). However, we still designed with a battery in mind for hull shape, weight balancing, and to prove real-world applicability in the design.

As previously discussed, SAVER was originally planned to be deployed using up to a Group 2 UAV, which puts considerable constraints on size and weight capacities. Generally, Group 2 UAVs have a maximum weight of 55 pounds, while Group 1 UAVs can only carry up to 20 pounds (“Micro-g NExT 2021 Design Challenges”). Some of the leading UAVs in the Group 2 category have been shown to have a payload capacity of between 22 lb and 35 lb (PrecisionVision 35). Given the constantly evolving nature of UAV technology as well as NASA allowing teams to design for Group 2 loads without penalty, it was originally planned to design our craft for the current upper limit of the industry for Group 1 UAVs. However, following the change in scope of the project, these weight restrictions were no longer considered in the final design.

3 – Objectives

This section details the goals of the team and the initial scope of our design problem.

3.1 – Problem Statement

To alleviate the need to divert power from the main rescue effort and to respond to other search and rescue needs more rapidly, NASA's landing and recovery team needs an autonomous water vehicle to help locate and aid astronauts who have been separated from their crewmembers.

3.2 – Boundary Diagram

Figure 3.1 shows how the SAVER product interacts with its environment. In this boundary diagram, the dotted line represents a boundary where objects inside are within design control, objects on the border must be interacted with but are outside of design control, and objects outside are beyond the need of consideration. SAVER first must interact with the signal of the ANGEL beacon, where it will be dropped within range of the target by an unmanned aerial vehicle (UAV) onto the surface of the water. It must also safely interact with the target.

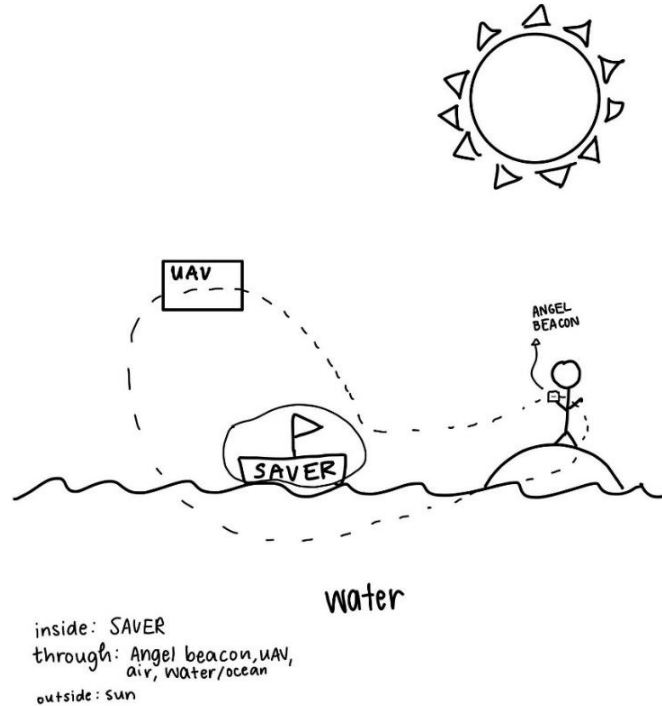

Figure 3.1. Boundary diagram showing what is within design control and how the product interacts with its operating environment.

3.3 – Quality Function Deployment

Upon defining the product and its environments, our next step was to develop a full quality function deployment (QFD) diagram, also called a House of Quality, to help identify the necessary design specifications. The full diagram is in Appendix A of this document. This House of Quality identifies and organizes customers, needs and wants, competitors, and specifications for the product. The process of researching and relating these categories helps us to think through priorities, strengths, and weaknesses, as well as to have a singular place to reference this information.

From the problem statement and preliminary research, we determined a full list of customers, or “Who’s,” involved in this process. The first is the sponsor of the project, NASA’s Landing and Recovery team, who had a need for the product. This product is needed to aid a search and rescue team to serve astronauts, making up the next two customer categories. Finally, the manufacturers creating the product will also be involved in the process of working with the device, and thus must be considered during the design phase.

Fortunately, our sponsor needs and wants are distinctly laid out in the challenge description for SAVER. These are:

- The vehicle shall be capable of being dropped from a 10-15-foot height into the maritime environment.
 - The vehicle shall be capable of being carried on a Group 1 (small) or Group 2 (medium), close range UAV.
 - The vehicle shall be capable of transporting (carrying or towing), at a minimum, the following items to the victim:
 - a. Water (1 liter minimum - 2.5 Liters max per Human Systems Integration Standard)
 - b. Medical kit (Orion 0.6 lb. kit)
 - c. Spare Life Preserver Unit (LPU)*
 - d. Contingency/Spare 406 MHz Second-Generation Beacon (ANGEL)
 - e. Survival Radio Optionally, the following may also be included:
 - f. Inflatable life raft (considering size/mass considerations)
- * Note: A pair of Orion LPU lobes with an existing, integrated ANGEL beacon may be used in lieu of other options for requirement c.

- The vehicle shall be capable of using existing equipment to detect the ANGEL beacon 121.5 MHz homing signal in order to guide the vehicle toward the beacon.
- The vehicle shall be capable of traveling to the person in distress via the most direct route in an autonomous manner, including:
 - a. Unmanned operation (no local or remote human intervention)
 - b. Programmed with mission profiles to address specifics of rescue scenario.
- The vehicle shall include protections in software/hardware to ensure no harm to the crew upon arrival in their vicinity.
- The vehicle must be able to float in water.

From here, we identified our engineering specifications based on these needs and wants of the client. The specifications provide a clear design goal and a quantifiable way to test verify that goal is met.

3.4 – Scope Re-evaluation

These engineering specifications were critical in the formation of our initial design direction. However, as mentioned in the introduction and further expanded in the final design chapter. Cal Poly SAVER was not chosen to compete for the 2020-2021 competition year. As a result, we developed a new set of engineering specifications based on the knowledge we gained in pursuing our initial goals, with the targets and risks determined based on our practical experience thus far. This new set of specifications can be seen in Table 3.1.

Table 3.1. Engineering specifications table.

Spec. #	Specification Description	Requirement or Target	Tolerance	Risk	Compliance
1	Beacon Bearing Angle	5% Uncertainty	Max	H	T
2	GPS position	± 15 feet	Max	L	T
3	Triangulated Distance	± 25 ft when within 100 ft	Max	H	T
4	Detection Consistency	Above 50% at 50 ft	Min	M	T
5	Detection Confidence	Above 25% at 50 ft	Min	M	T
6	Depth Mapped Distance	±1 foot when withing 10 feet	Max	H	T

Compliance is the way to determine whether a design meets a specification. The methods and labels associated with it are Testing (T), Analysis (A), Inspection (I), or Similarity to an Existing Product (S). The following is how our team intends to measure each specification:

1. The bearing to the beacon will be found by measuring the phase of the radio wave with four antennae and comparing the phases at each antenna. This phase data, along with the known geometry of the antenna placement, will allow us to calculate the angle to the beacon sing trigonometry.
2. The GPS position will be measured with the GPS module attached to the Jetson and compared to a cell phone with GPS position data at the same location.
3. The triangulation must be able to reliably estimate the position of the beacon to within 25 feet so that the close-range detection can activate within its required window. This will be tested.
4. The detection consistency denotes what percentage of frames yield a successful detection. This will be tested.
5. Detection confidence is the average certainty with which the neural network categorizes the target.
6. Depth mapped distance is the distance estimated by the close-range detection. This will also have to be tested.

There are a significant number of high-risk specifications for this project. The first is the beacon bearing angle. We rated this as high risk because we are using a budget system that will require much of our own work to get reliable results. The triangulated distance is also high risk. This is simply because the uncertainty of the bearing angle also propagates into the triangulation. Finally, the depth mapped distance is high risk because while it is a fairly common practice, most commercial uses are using proprietary software to do so, and we will be attempting to create our own. We are deciding to devote our time to these challenges, because we believe they must be tackled in order for future teams to progress.

4 – Concept Design

This section details the processes we undertook to create our first concept for SAVER, as well as how our ideation process developed.

4.1 – Ideation

We took part in multiple activities to develop innovative solutions for SAVER. The function tree in Figure 4.1 was created in order to break the SAVER device into its functions. In order to get to that point, we brainstormed on the Google Jamboards found in Appendix B.

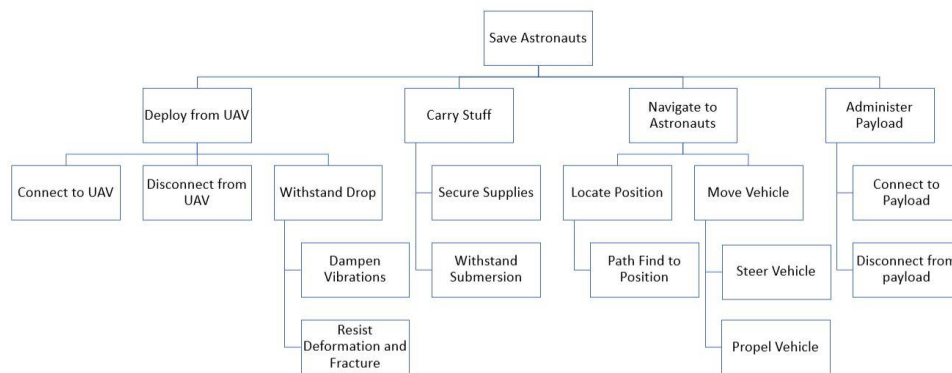

Figure 4.1. Function tree for SAVER.

We determined that in order to complete the main function of saving astronauts, four main subfunctions needed to be achieved. SAVER must: deploy from the UAV, carry the supplies for the victim, navigate to the victim, and administer supplies to the victim. The designs resulting from this ideation must perform these functions to be considered. The four functions were then distributed to the members of the team for concept and prototype models to be produced. These models can be found in Appendix C.

To see how each model ranked against one another, we created Pugh matrices. A rating was given to each model based on how each preformed the given function. An example would be rating how well a hinged hatch design would administer the load and carry the supplies to the astronaut versus how a detachable payload design. The matrices can be seen in Appendix D. The Pugh matrices allowed us to discard any designs that could not perform their functions or meet certain requirements. The top five ideas for each function were put into the morphological matrix in Figure 4.2.

Table 4.1. Morphological matrix for top five ideas of each function

Function	Idea 1	Idea 2	Idea 3	Idea 4	Idea 5
Safely Enter Water without Damage	Shaped Hull	Glider Wings	Parachute	Shock Absorber	Torpedo
Propulsion/Steering	Dual Side Propellor	Back Propellor / Rudder	Jetski with Rudder	Jetski with Transverse Jets	Torpedo Propellor
Shell Design	No shell (propeller only)	Pontoon	Torpedo	Regular Boat Shape	Stealth Bomber Style
Carry payload	Pull payload behind	Detachable payload	Interior compartment for payload	Top Loaded Payload	Top Loaded Payload
Keep internal hardware isolated	Latch	Threads	Locking Lid	Buckle	Pin
Stability	No fins	One fins	Two fins	Stabilizing arms	Pontoon

Each team member then created a full concept design for SAVER using these function ideas. The member would choose what they thought could be a viable design for each function and combined them to create a complete system. Each team member created a top idea from this matrix, which would then be evaluated against the other designs. Idea 1 had a shaped hull with dual side propellers attached to pontoons, with an internal latched payload. Idea 2 featured a torpedo shape with jet ski propulsion and a hinged locking lid which held the payload internally. Idea 3 chose a shaped hull with dual side propellers and pontoons much like Idea 1, except the payload was strapped and buckled externally to the rear and the propellers were against the body of the hull. Idea 4 showcased a shaped hull with shock-absorbing pontoons, a jet ski propulsion system, and a hatched lid hiding the payload internally. Ideas 5 and 6 were both propelled by a jet ski system and latched lids for internal payloads, but Idea 5 had a shaped hull with a weighted bottom while Idea 6 had a torpedo-like hull with two fins. Lastly, Idea 7 incorporated a torpedo-style hull with winged propellers and a latched lid for storing the internal payload. To compare and debate each design, the weighted design matrix in Appendix E was created and analyzed. Images of the designs are also included in that appendix.

4.2 – Concept Selection

The two designs that tied in score in the weighted decision matrix analysis were Idea 2 and Idea 3 – a jet-ski style propulsion system with a rudder to steer, and a dual propeller system for steering and propulsion. We investigated the pros and cons of both designs to come up with a design which combined the strengths of each. Upon discussion, we determined that the jet-ski design would be more difficult to control at lower speeds, due to the single motor, and manufacture. Additionally, this type of propulsion is less common for small craft than propellers,

and thus would have been more difficult to research going forward. Furthermore, the inclusion of two propellers for both steering and propulsion allow for a simpler controls system, since both forward motion and rotation could be controlled by throttling one or both propellers. Another large disparity between the two designs was whether the payload should be internally or externally mounted; the jet ski design had the payload inside of the hull while the propeller design had the payload mounted inside a removable container on the outside of the hull. Ultimately, we decided to store the payload inside of the hull to facilitate efficiency in hull and propulsion, as well as to eliminate the possibility of the payload separating from the hull. Additionally, this decision allowed us to focus their design efforts on a single hull shape rather than a hull, payload container, and mounting mechanism. In order to best survive the impact with the water, both designs featured a pointed hull. Since both designs had this feature, it was selected for the final design. Additionally, this pointed hull design allowed for increased hydrodynamic efficiency when interacting with the water. With these ideas in mind, we combined the strengths of each design and decided on a final concept design which features a pointed hull, two side mounted propellers for propulsion and steering, and an internal compartment for the payload.

4.3 – Design Direction

In December 2020, we received news that we were not selected to continue participation in NASA’s Micro-g NExT competition. We continued with the project but treated it as a proof of concept for later teams at Cal Poly to work off of. This means we worked at a decreased scale to simplify manufacturing and did not adhere to some of the requirements set by NASA such as the weight, max speed, and specific frequency for the distress beacon. The final design reflects these changes, but the concept design is based off the full-scale design.

The concept design features a propeller-driven craft with a shaped hull and an internal storage compartment. A sketch of this concept design and our initial CAD model are shown in Figures 4.2 and 4.3. We also investigated using an electronically opened hatch for ease of access, as well as visual and auditory indicators on the craft to make it easier to locate in cases of low visibility but concluded that these.

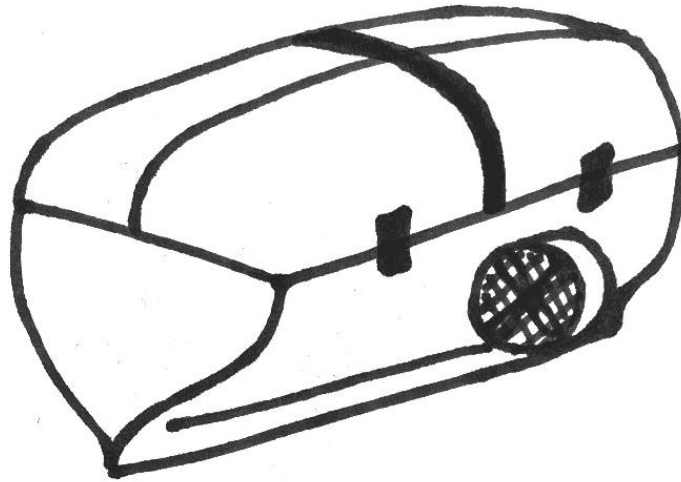

Figure 4.2. Sketch of final design direction.

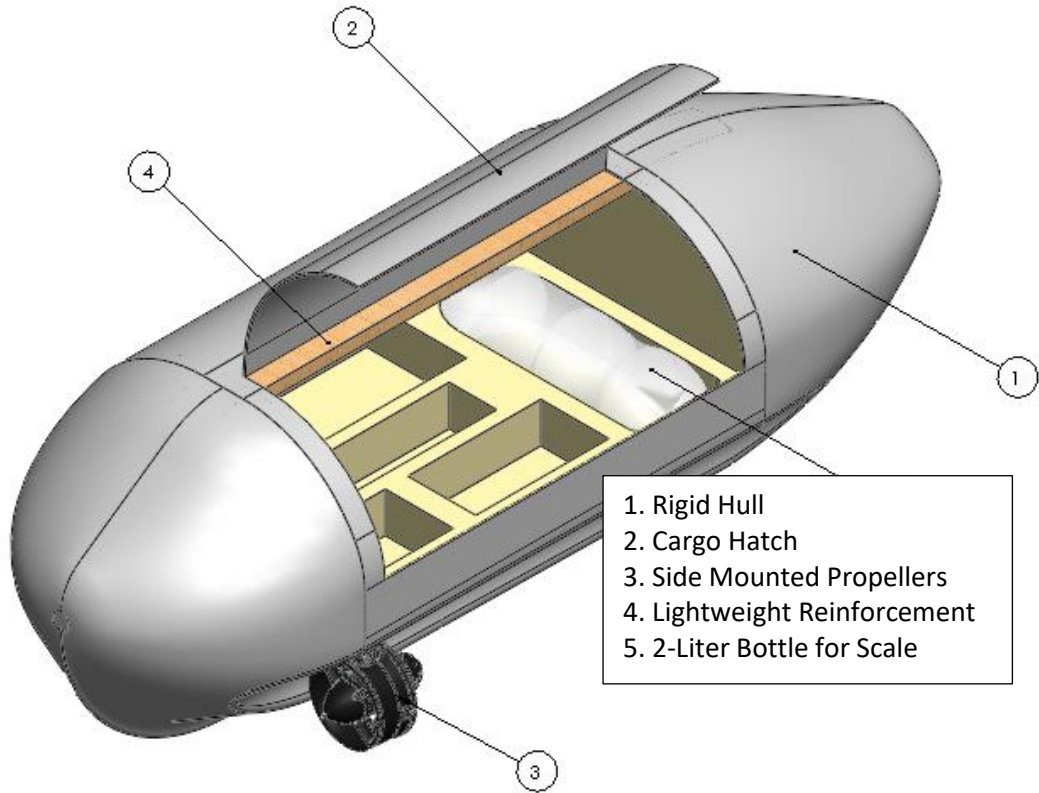

Figure 4.3. Isometric view of preliminary CAD model.

4.3.1 – Manufacturing

The manufacturing of SAVER will be divided by main subsystems of the vehicle. The main shell houses the key electronics, propulsion systems, and payloads required for the competition. This section will serve to highlight the various ways in which manufacturing SAVER's shell may take place. Additionally, the components used for controlling and propelling the vehicle will be discussed in a later subsection.

4.3.2 – Mechatronics

Autonomy of the SAVER device will be directed by a microcontroller running in a multitasking configuration. This allows the device to perform beacon-locating and direction-finding while simultaneously acting as the brain of the propulsion and steering subsystems. This functionality is crucial to ensure that the craft will be able to update navigation calculations without interrupting the execution of existing instructions.

To accomplish tracking of the ANGEL beacon, Cal Poly's SAVER device will utilize the Watson-Watt method of radio direction finding. Research on radio direction finding methodologies revealed that other common devices such as Doppler (or pseudo-Doppler) and interferometry were not suitable due to the craft's size constraint and the frequency that is desired to be tracked respectively (Wei). A Watson-Watt device, however, can easily be designed to provide accurate and cost-effective results that meet our requirements.

The Watson-Watt method works by using an array or loop of antennas to compare the phase disparities over a known area. The distress signal will induce a sinusoidal voltage in each of the antenna with known amplitude. Since the wavelength of the signal and the distance between antenna pairs are known, the difference in phase can be used to determine the orientation of the antenna pair to the signal origin (Rudersdorfer). To compare the voltage signals, discrepancies such as polarization or multipath errors must be eliminated through extensive filtering and calculation (Sadler). This is not a trivial step, and will take hundreds of hours of coding, testing, and configuration to tune. After SAVER's microcontroller completes these processes, a bearing angle towards the distress beacon can be produced. A simplified schematic of the Watson-Watt process is shown in Figure 4.4.

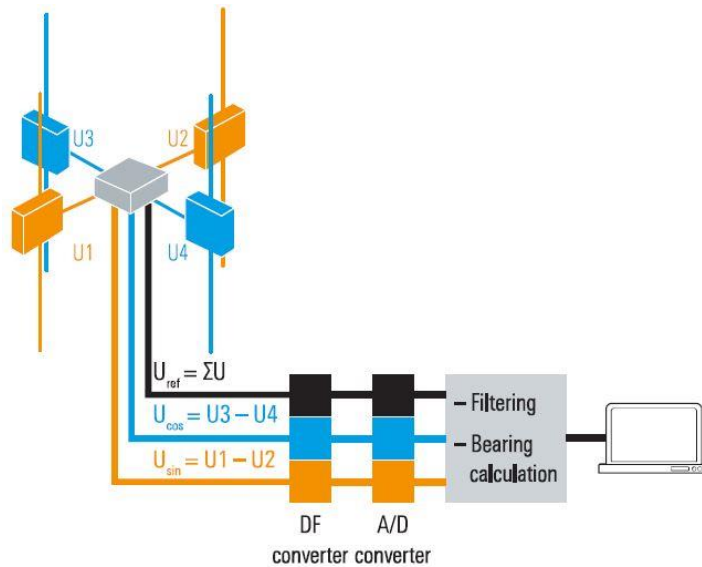

Figure 4.4. Schematic of Watson-Watt system using Adcock antenna. U1-4 are the voltage signals coming from the antennas, passing through a A/D converted to the computer for filtering and calculations (“Introduction to the Theory of Direction Finding” 33).

A compilation of the bearing angles will allow SAVER to create a path to the most likely position of the beacon. As more bearings are collected, the position will become more accurate, and the path will become more up to date. Storing the path would be a necessary feature in case the signal from the beacon is lost. SAVER will still be able to carry out the mission by following its most recently updated path to the last known position, even without a consistent signal. The SAVER team will model this response in MATLAB to tune the path creation process before implementation onto the microcontroller. The path will also be pulling points for propulsion and steering values due to the variability of the direction-finding outputs, acting like a damper in a mechanical system. More research needs to be done into a microcontroller with adequate processing power and antennae with sufficient range for the 1 square nautical mile that SAVER needs to act in.

Two thrusters will be mounted both sides of SAVER to achieve our propulsion and steering. The thrusters will be individually controlled to allow steering via differential power allocation. This will require two separate motor controllers. More extensive drag calculations and fluid simulations will need to be carried out before selecting the exact thruster, but the SAVER team intends to purchase them from a third party.

4.4 – Preliminary Analysis

To get an estimate for thrust capability of the propellers, a simple drag calculation may be used. The specification for this device states that the maximum speed must exceed 2 meters per second. The hull of the device can be modeled as a stationary sphere with a drag coefficient of 0.5 in a flow of water moving at 2 meters per second (Pritchard).

$$F_D = \frac{1}{2} C_D \rho V^2 A \quad \text{Eq. 1}$$

The estimated height and width of SAVER is 1 meter by 0.3 meters. In order to simplify the model, the sphere will be dimensioned at a diameter of 0.4 meters to mimic the front portion of the device. Assuming incompressible flow and neglecting drag from the air, Equation 1 can be used with $\rho = \rho_{\text{H}_2\text{O}} = 997 \text{ kg/m}^3$ and frontal area, $A = \frac{1}{8} \pi D^2$ (Pritchard). Half the surface area of the sphere was used in the equation because only half of the boat is in the water.

$$F_D = \frac{1}{2} (0.5) \left(997 \left[\frac{\text{kg}}{\text{m}^3} \right] \right) \left(2 \left[\frac{\text{m}}{\text{s}} \right] \right)^2 \left(\frac{1}{8} \pi (0.4 [\text{m}])^2 \right)$$

$$F_D = 63 \text{ N}$$

This means that the dual-propeller setup must produce at least 63 Newtons of thrust in order to achieve the required maximum speed. The thrust of propellers is usually given in units of kilograms, resulting in a minimum thrust capability of 3.2 kilograms per propeller. This yields information about the size and cost of similar propellers which can be used for initial budget and designs for SAVER.

4.5 – Risks, Challenges, and Unknowns

From initial analysis, we anticipate two major areas of concern regarding safety during the testing and operation of the vehicle, along with other factors that may arise during the construction and testing phases. Those areas of greatest concern are electrical isolation and propeller impedance during operation, as well as material safety concerns and challenges related to manufacturing, assembly, and testing safely during COVID-19. A full hazard analysis accompanied by potential solutions may be found in Appendix F.

In order to mitigate the risk of electrical hazard we will ensure that all electrical components are contained within a watertight container, or “dry box,” and that all connections

between this dry box and the NBL are thoroughly protected against contact with water. This isolation and protection will be tested using a prototype of the dry box and external connection points with power disconnected in order to verify the safety of the design.

Additionally, the rotating propellers providing propulsion and control of the craft could pose a hazard should a foreign object or any external testing equipment contact the blades. In order to mitigate this risk, the propellers will be protected by cage-style covers. The efficacy of the covers will be ensured by testing the craft in an environment with debris in order to verify that they prevent contact between the propellers and any foreign objects.

Currently, we are strongly considering using a fiberglass composite material for SAVER. This material, and the resin used in the fabrication process, poses certain dangers during the manufacturing process. We will continue to research safe practices for working with fiberglass, including consulting with composites professors at Cal Poly, to ensure that all potential risks are known and that all necessary precautions are taken. Additionally, given the current restrictions as a result of the COVID-19 pandemic, we will have very limited access to the fabrication facilities usually available on campus. With this in mind, we plan to focus the design efforts on maximizing the number of off-the-shelf parts and minimizing the need for specific manufacturing. Additionally, we will prioritize a design which can be easily manufactured and assembled in separate locations, based off each team members individual ability to create different parts of the design. Given that it will be difficult for us to meet for manufacturing and assembly, this approach minimizes the risk of contracting COVID-19 without preventing us from being able to manufacture or assemble the design.

Once a working prototype is fabricated, the following tests will be conducted to ensure the safety of the design. The safety testing procedure is listed below.

Safety Testing Procedure:

Electrical Shock

1. Circuit Dry Box

- a. Fully submerge SAVER for 1 minute
- b. Remove SAVER from water
- c. Check for leaks using chlorophenol red water detection paper

2. External Power Supply

- a. Connect SAVER to external power supply
- b. Remove SAVER from water
- c. Check external power supply connection for leaks using chlorophenol red water detection paper

Propeller Impedance

1. Waterborne Debris

- a. Operate SAVER in testing pool with small debris like that which may be found in the ocean
- b. Remove SAVER from water
- c. Inspect propellers for damage

2. Propeller Strike

- a. Strike SAVER propeller guards with small piece of foam
 - i. Check foam for cut marks to ensure propeller does not strike outside of the guard

5 – Final Design

In December of 2020, we received news that we were not selected to continue participation in NASA's Micro-g NExT competition. We used this opportunity to shift our focus away from rushing a full-scale prototype, and toward building a strong foundation to help propel future teams at Cal Poly to work off of. We have chosen to decrease our scale in a way that minimizes time spent on the simpler aspects and allows us to focus on the toughest challenges. We are also no longer have to prioritize adhering to certain requirements set by NASA such as the weight, maximum speed, and specific frequency for the distress beacon. The final design will reflect these changes, but the concept design was still based off the full-scale design.

The new scale allowed for a cheaper alternative components for the design. Notably, we are now able to select the frequency of the distress beacon, which allows for much smaller and less expensive antennae to be used as compared to the original design. Additionally, we switched from a composite hull design to a 3D printed hull to save time, material costs, and to simplify the manufacturing process. An updated version of the CAD model for SAVER is shown below in Figure 5.1.

For the final design with regards to electronics, it is important to focus on the concepts rather than the components. Due to the budget limitations and new scale, the parts showcased in this design report are used to provide evidence that our design could work at the full scale and with the proper budget. The electronic design is broken up into three subsystems that will allow SAVER to operate through the necessary stages: radio direction finding, proximity detection, and power distribution. The next sections will go through the concept of the designs and the stages the boat's electronics will operate in.

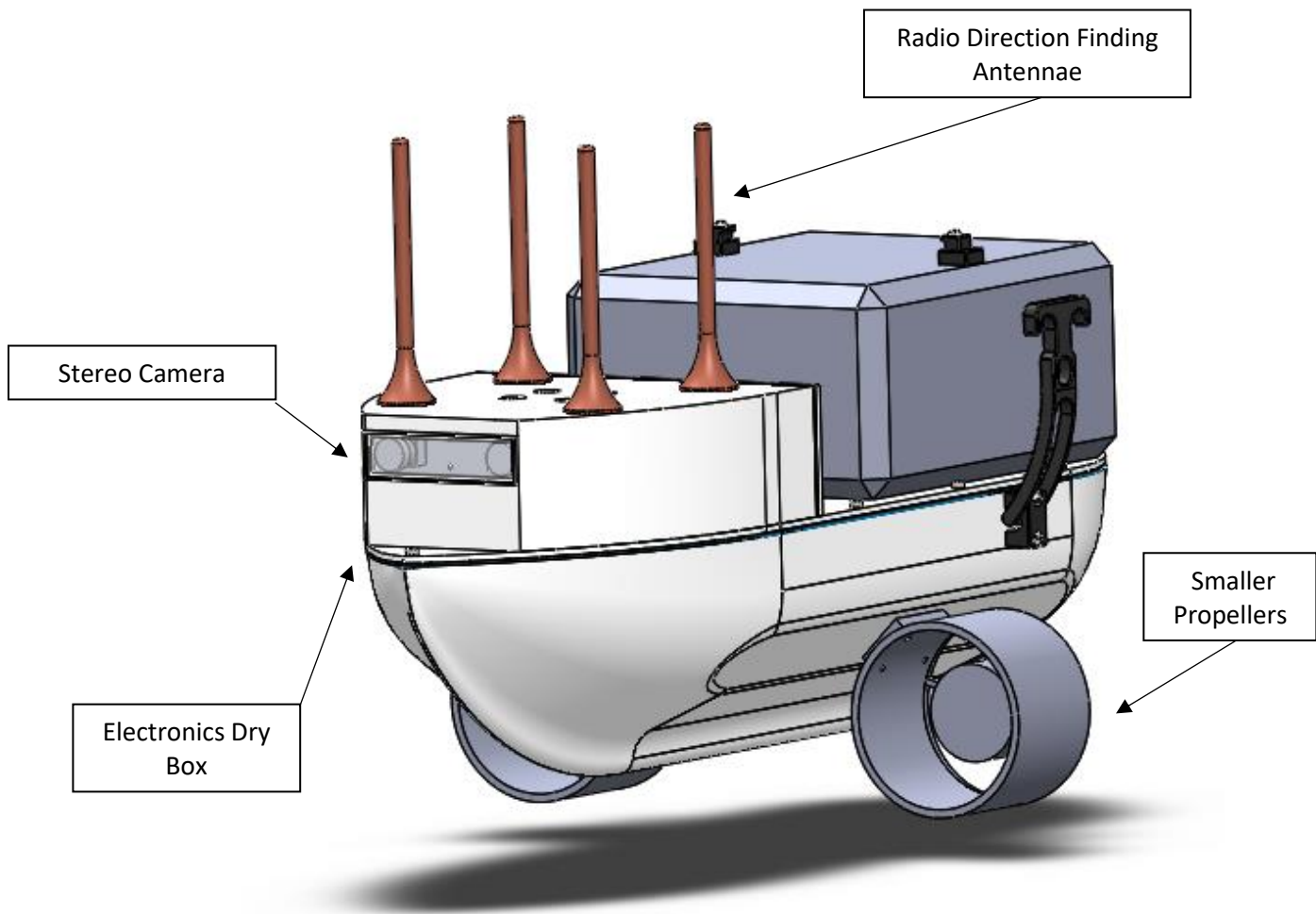

Figure 5.1. CAD model of finalized SAVER design.

5.1 – Radio Direction Finding

In order to track the beacon once dropped, SAVER will use software-defined radio direction finding to calculate a bearing in that direction. As previously stated in the research section of the project, there are multiple ways radio direction finding can be done across a wide range of frequencies, but SAVER is tracking a 446 MHz signal, which is on the lower side of radio frequencies. This complicates the detection abilities of many devices because of its long wavelength. Due to this, we are limited to single-channel direction finders using amplitude or phase comparison technology. These technologies use an antenna array, usually consisting of four to seven antennae, that compare the amplitude or phase of the wave at each antenna. For SAVER, only four or five could possibly be used due to size constraints but would still be able to provide 360-degrees of detection.

In the case of a four antennae system running with phase comparison, the antennae will receive a signal from the distress beacon at four different phases of the same wave form. Figure 5.2 shows an illustration of how this works. These phases are compared using software and known geometry of the antenna array to output a bearing. Using an off-the-shelf project that can perform these calculations and output the correct variable type with limited modification is necessary if the scope of the project is to stay within the mechanical engineering senior project setting. Otherwise, the project would need to utilize the expertise of software and electrical engineers.

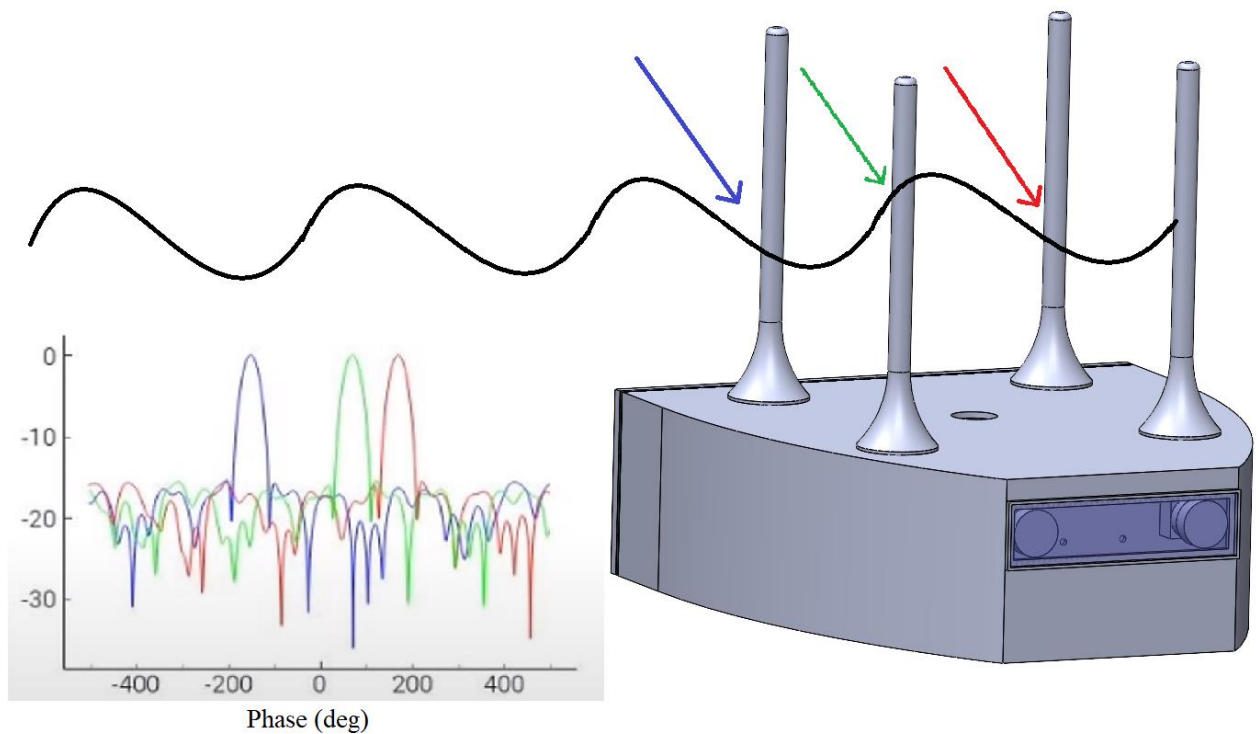

Figure 5.2. Phase difference in that each antenna sees to find direction. The colors on the phase histogram on the left shows the signal received by the corresponding antenna on the right.

The KerberosSDR in Figure 5.3 is an off the shelf device that integrates four channels of software defined radio signals from four separate antennas for direction finding. The reason behind the choice of the Kerberos is due to its price and the accessibility of the data. Most software defined radio receivers can only transmit data from one antenna. The Kerberos integrate four channels that are accessible through one data connection, making it simpler to perform phase coherence analysis simpler to perform software-based phase coherence analysis. It would be possible to fabricate a similar device using single receivers and four antennas, but the upgrade to the Kerberos will save hundreds of hours of software development that is beyond the scope of this project. The downfalls of using the Kerberos comes from its quality. High precision radio direction finders can tally a price of over \$5,000, but the Kerberos only runs for \$300. It is more of a hobbyist tool for direction finding rather than precision tool that is needed on a full-scale SAVER device. That being said, the Kerberos is a sufficient tool for learning the ins and outs of radio direction finding and perform adequately for a proof of concept, which is why it was chosen for this project.

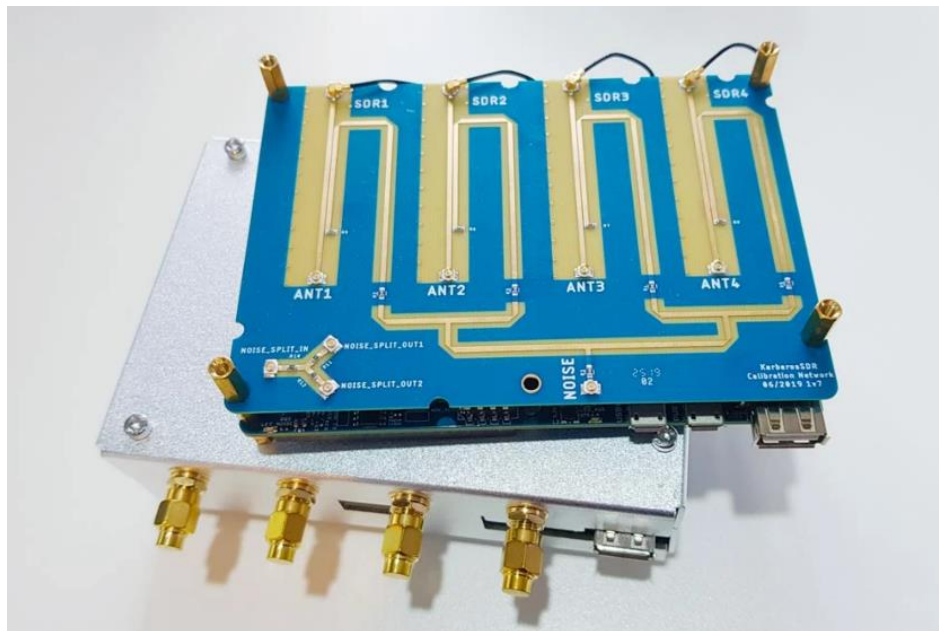

Figure 5.3. Othernet’s KerberosSDR with 4 channel coherent RTL-SDR.

Because of its use in calculations for bearing, the distance between each element of the antenna array is critical. For the test signal of 900 MHz, each array needs to be spaced apart 100 millimeters. This distance is calculated by converting the frequency of the signal to its complimentary wavelength and multiplying by the Kerberos's spacing factor of 0.3 which is set by the manufacturer. This critical dimension led to the design choices for the exterior bow box in Figure 5.4 that will house the stereo camera system and position the antennas correctly. This device will be located by pins on the flat hull top to provide some height to the camera and antennas for better vision and reception.

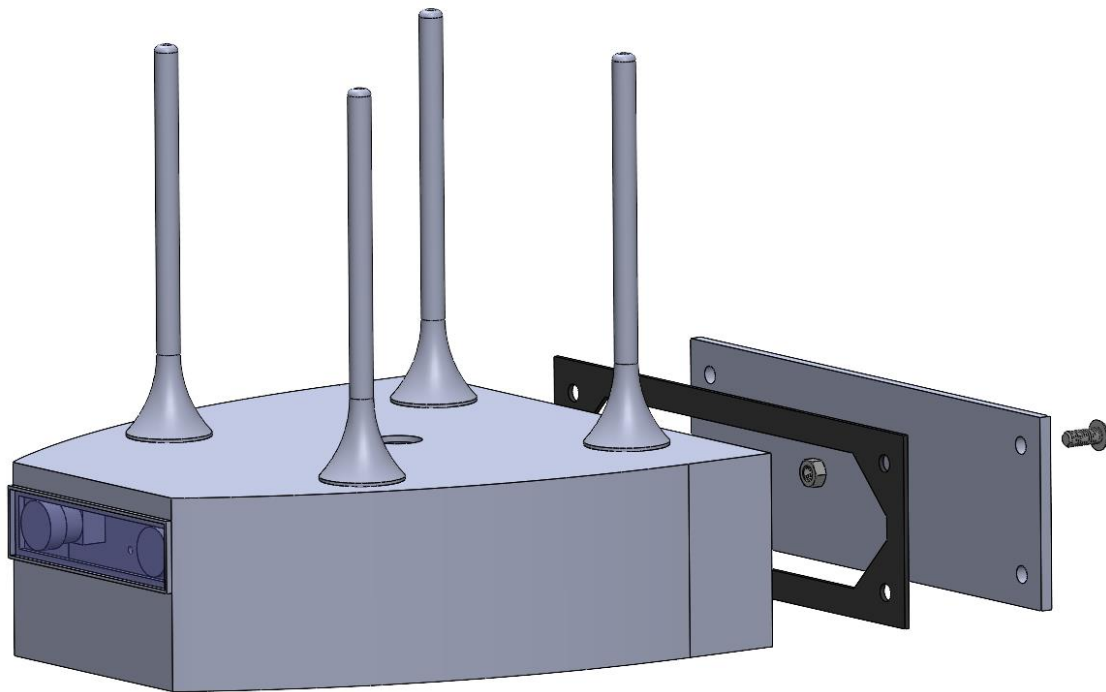

Figure 5.4. Exterior bow box housing stereo camera and positioning antennas. Uses gasket design for waterproofing and a polycarbonat window to allow vision for the stereo cameras but still provide waterproofing. The hole of top will be filled with a waterproof wire pass through which will feed the antenna wires inside the housing.

5.2 – Close Range Navigation

Once SAVER approaches the target, triangulation no longer becomes viable, so we depend on the image recognition and depth mapping system. This system works by analyzing an image to recognize the astronaut, and then calculate a distance by comparing this image to the image produced by a second adjacent camera. We chose to use this method because without a visual recognition, it would be very difficult to determine whether a detected object is actually an astronaut, or nothing more than a wave or debris. Additionally, using stereoscopic depth mapping is advantageous because it only requires that the astronaut be within view of the camera, and the recognition can be used to pinpoint the location of the astronaut within the field of view easily. By contrast a method such as an ultrasonic sensor would not be able to discriminate in the distance it provides. We also considered the use of a thermal sensor instead of a visual system, but the interference due to the cold water makes such an approach impractical.

This system will activate when the triangulation software estimates that the device is within 50 feet of the astronaut. Our initial research showed that we should be able to get the distance to within about a foot of uncertainty, which is necessary if we are going to position SAVER close enough to the astronaut.

The requirements of the SAVER's microcontroller led to the choice of NVIDIA's Jetson Nano. The Jetson met the more basic requirements of being able to utilize a stereo camera with its two CSI camera connectors and being powerful enough to run simultaneous software to interact with the Kerberos in testing. The main justification for the Jetson for this project, however, is its ability to efficiently run a detection network due to its graphics heavy architecture. NVIDIA has created an AI capable of finding an array of objects within an image, including humans, through learning done on billions of images. Figure 5.5 shows an example of how this image recognition works.



Figure 5.5. Image recognition done by the Jetson. Contains probability calculation results with each person.

By combining this AI with a stereo camera, image recognition can be used on one of the camera outputs to find the astronaut in the water, and a depth mapping program can be run by utilizing both cameras. These stereo cameras, like the one in Figure 5.6, work on the same principle that a person's eyes use for depth perception.

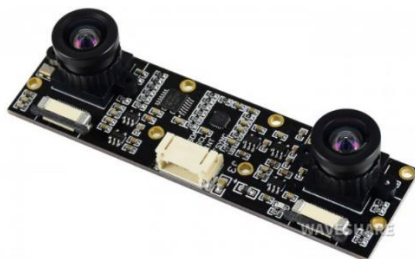

Figure 5.6. Stereo cameras that will be used for image recognition and distance finding.

To build our depth maps, we decided to go with an OpenCV based depth mapping code. OpenCV is an open source computer vision library that has many powerful tools for our application. We decided to use this library due its vast user base and python support, allowing us to stay consistent in our programming language. One of the algorithms available in OpenCV is the “Semi Global Block Matching” algorithm, which compares recognizable blocks in both images to calculate the disparity between them. The closer the object, the greater the disparity between images. Using this information, we can then calculate the distance to the object based on the known distance between the cameras.

5.3 – Propulsion and Power

SAVER will use the principle of the dual thruster system with differential power system that allows turning in the water by supplying a different amount of power to each thruster. Two thrusters will be mounted to the sides of the hull and be powered through individual electric speed controller which will allow for the differential power steering. A smaller duty cycle voltage output from the microcontroller to the speed controller will be upscaled to the proper power input needed by the thrusters from a single lithium-ion battery. The battery will also power the Kerberos and Jetson with the use of battery eliminator circuits or BECs. BEC's were created for RC vehicles to step down power to a particular voltage and amperage to eliminate the need for running multiple power units in a small form factor device. This power system will allow for portability of the boat which will save time during testing.

After the speed requirements were dropped from the project, thruster selection became more based off price rather than thrust. A lower end thruster allows us to test the validity of the steering and navigation principles at a lower speed and price.

The 3-blade 12-volt propeller in Figure 5.7 is an RC boat propeller from the brand Yuenhoang and is capable of exceeding the minimum thrust requirements for the half scale device. The minimum thrust was found by performing a rough drag calculation for how much drag the vehicle would experience at 2 meters per second, the maximum speed requirement that was originally defined by NASA. While we no longer have to test whether this speed may be reached, it gives us a good ball-park value to shoot for to prove the concept works. This drag force, whose governing equations are located in Section 4.4, is found to be 12.4 Newtons for the reduced vehicle size. One of the chosen propellers is capable of providing 29.43 Newtons of thrust at full power which will be plenty for testing. These thrusters also feature an enclosed design which protects the blades from debris and the user from the blades.



Figure 5.7. 3-blade Yuenhoang propeller thrusters.

SAVER will use a generic 12-volt 3S lithium-ion battery. The 3S type corresponds to the maximum current output which exceeds the power needed for full thrust from the Yuenhoang propeller thrusters. For testing, SAVER will be in a wired configuration to lengthen operating time using a 12V power supply capable of at least 10 Amps. Figure 5.8 shows a brief overview of how each piece of the electronics in SAVER will interact in power distribution and information transfer.

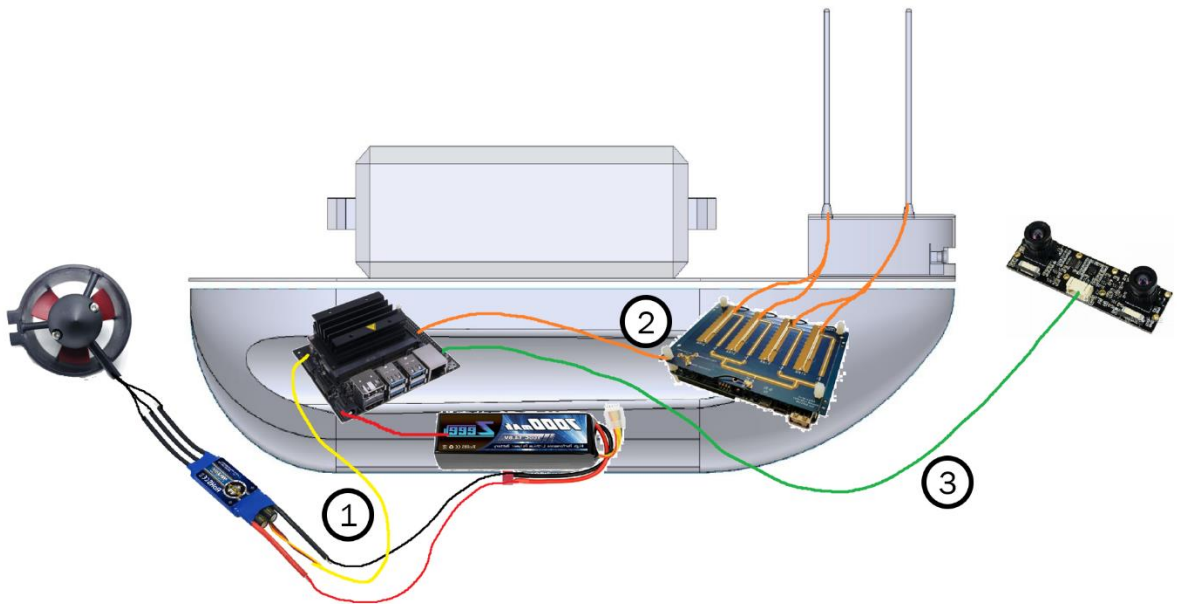

Figure 5.8. Overall schematic of electronics in SAVER. The brain of the operation will be the NVIDIA Jetson. This will act as the microcontroller for the differential power system between the thrusters and the battery (1), run custom software to compare signal phase from the KerberosSDR and antennas (2), and utilize its preloaded artificial intelligence in junction with a stereo camera (3).

5.4 – Stages of Operation

To get from the drop location to deploying the payload to the astronaut, SAVER will run through a sequence of four stages. Once dropped, SAVER will go through an initialization stage. A sequence of lateral movements will allow the initial bearings to be read from the radio direction finding Kerberos and the beginnings of a triangulation survey to be conducted. The triangulation software will calculate the possible point the beacon is located along with a confidence interval. SAVER will then start its next stage using only direction finding to navigate.

Once an initial bearing is found, SAVER will move at a 5-degree offset from that bearing and store it in memory along with the current GPS data. Over time this record of previous bearings and GPS locations will be used to triangulate the position of the beacon. From this data a probability zone will be calculated for the beacon location in real time. This zone will shrink the more data SAVER collects, but this method is fundamentally limited in its accuracy due to the uncertainty in bearing angles, which when compounded with the small angles that are being worked with, lead us to design a third stage of navigation. An example of how this will be performed is shown in Figure 5.9.

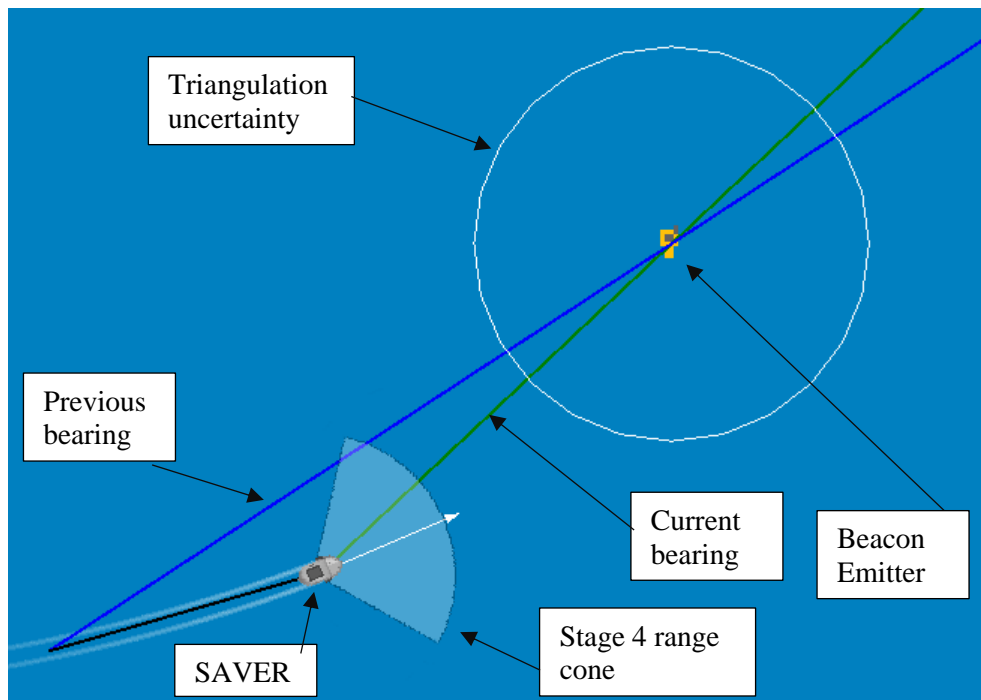

Figure 5.9. Simulation showing graphically the triangle created using the two bearing angles and the line segment generated by the difference in position. See appendix E.1 for triangulation pseudocode.

Since direction finding is only effective outside a particular range, the team needed to find a way to accurately measure the distance to the target so that SAVER can reliably position the payload 3 feet from the astronaut. When SAVER is within a range of 50 feet of the high probability zone, the third stage will begin. Navigation in this stage will be taken over by image recognition software searching the waters in front of the boat for the astronaut. SAVER will use artificial intelligence paired with a stereo camera to find the astronaut and the distance to them. This pairing will be able to find the location of the astronaut at a much higher precision than the direction-finding triangulation. The final stage begins when SAVER is within 3 feet of the astronaut. All power to the thrusters will be cut for safety purposes and the device will wait for the astronaut to take the payload.

6 – Manufacturing

This portion of the report will highlight the processes we followed to manufacture our verification prototype. The smaller scope of the project allowed us to focus more of our efforts on creating functional versions of each necessary component of the system, rather than a unified single prototype. For example, the radio beacon signal was changed to 915 Hz in order to be more easily detected by the KerberoSDR system. Additionally, the motors and propellers used to drive SAVER were reduced in size to coincide with the lessened thrust requirements. The original manufacturing plan for the mechatronics subsystem is shown below in Table 6.1. However, we ended up spending far more time working on the code needed to refine the KerberoSDR and NVIDIA Jetson camera systems than initially anticipated, and as a result, some of the planned manufacturing operations were not performed due to a lack of time. These changes to the original plan and the actual manufacturing processes undertaken are detailed in the following sections.

Table 6.1. Navigation and Controls Subsystem Manufacturing Plan

Subsystem	Component (Highlighted = Purchased)	Purchase (P) Modify (M) Build (B)	Raw Materials Needed to make/modify the part (only M & B)	Where/how procured?	Equipment and Operations anticipate using to make the component	Key limitations of this operation places on any parts made from it
Microcontroller	Nvidia Jetson Nano (4GB) V3	P	n/a	Purchased from Nvidia	n/a	n/a
	Dry box	B	3D printer filament	Already owned	n/a	n/a
Cameras	Stereo Camera	P	n/a	Purchased from Waveshare	n/a	n/a
	CSI ribbon cable	P		Purchased online	n/a	n/a
	Camera shield	B	1/16" Clear Polycarbonate	Order from McMaster-Carr	Cut with tin snips and glued in place. Sealed with silicone	Polycarbonate must be protected from plastidip coating
Direction Finding	Antennas	P	n/a	Purchased online	n/a	n/a
	Kerberos	P	n/a	Purchased online	n/a	n/a
	IMU	P	n/a	Already owned	n/a	n/a
	GPS	P	n/a	Purchased online	n/a	n/a
Power Train	Thrusters	P	n/a	Purchased online	n/a	n/a
	Motor Controllers	P	n/a	Purchased online	n/a	n/a
	Wiring harness	B	Wires	Already owned	Solder/Soldering iron	n/a
	Power supply	P	n/a	Purchased online	n/a	n/a
Fasteners	Mounting inserts	P	n/a	Purchase from online supplier	n/a	n/a

6.1 – Electronics

Kerberos and NVIDIA Jetson:

The Kerberos and Jetson were originally planned to be bolted into their appropriate locations within the internal dry box. However, these systems were never fully integrated into the dry box, as we spent most of our time refining and tweaking parameters of these components instead of focusing on mounting them and having the different components interact.

As a result, the Kerberos was kept inside of a small cardboard box with its four antennae glued to the top. When operated, the Kerberos would be attached to a laptop to read the data and an outlet for power. Similarly, the Jetson was kept in a small cardboard box and attached to power and a monitor when in use.

Cameras:

We originally intended to bolt the camera to the bow box with screws and thread the CSI ribbon cable through the thin slit in the dry box, and then fill this slit with silicone to prevent leakage. However, as mentioned above, the cameras were instead attached to the Jetson in the same small box and were never mounted into the bow box due to time constraints.

Power Train:

The original plan for the thrusters included securing the motor controllers, battery, and battery eliminator circuit in their appropriate places as per the wiring diagram and connecting each of the components to their appropriate system within the dry box. However, we ended up connecting the thrusters directly to plug-in power instead of a battery and used a potentiometer and the electronic motor controllers to change the speed of the thrusters. After this proof-of-concept circuit was created, the thrusters were transferred to the hull and payload team, as they would be integrating them into the hull.

Antennas and Antenna Frame:

Below is listed the modified plan used to create and frame to hold the antennas and mount them on the bow box. However, for the reasons discussed above, this frame was mounted on the cardboard box holding the KerberoSDR instead of the originally planned 3D printed bow box.

1. Print the antenna frame in PLA filament, oriented with the bottom on the printing bed.
2. Remove any support material and inspect for defects.
3. Slip the antenna frame over the 4 antennas to secure them to the frame, then use duct tape to attach the frame to the top of the cardboard box housing the KerberoSDR.
4. Run all 4 antenna wires through the open end of the box and plug them into the KerberoSDR.

6.2 – Manufacturing Update

In sections 6.3-6.5 below, we have listed the original plans for manufacturing the bow box, internal dry box, and camera shield. However, given the previously mentioned circumstances and heavy focus on SAVER's electronics, we ultimately decided to forgo the manufacturing of these components. The manufacturing steps listed below are the procedures we would have taken to manufacture these components if able.

6.3 – Bow Box

Bow Compartment:

3D Printer

1. Print bow compartment in PLA filament, oriented with the open end on the printing bed.
2. Remove any support material and inspect for defects that might cause leakage. Fill or reprint, as necessary.

Spray Coating

3. Place the compartment open end down in a well-ventilated area and prepare surface for spray coating.
4. Tape off the camera cutout as to not affect seal later in assembly.
5. Coat the plastic evenly until none of the original print is visible.

Nuts

6. Set the nut into the hole using epoxy.

Bow Backing:

3D Printer

1. Print bow backing in PLA filament, oriented with the side that mates with the bow compartment on the bed of the printer.
2. Remove any support material and inspect for defects that might cause leakage. Fill or reprint, as necessary.

Spray Coating

3. Place the backing mating surface down in a well-ventilated area and prepare surface for spray coating.
4. Coat the plastic evenly until none of the original print is visible.

Camera Shield:

Tin Snips

1. Cut the camera shield to size as per the part drawing.
2. Remove any burrs with a deburring tool or by sanding.

Once finished, place a small bead of epoxy around the edge of the shield and set it into the camera cutout on the bow box.

6.4 – Internal Dry Box

3D Printer

1. Print the dry box and lid in PLA filament, oriented with the bottom on the printing bed.
2. Remove any support material and inspect for defects that might cause leakage. Fill or reprint as necessary.

Heat Set Inserts

3. Set the threaded inserts in the printed holes and bring them flush with the plastic using a soldering iron.
4. Fill the sealing lip with a thin, uniform layer of silicone to help further seal the box when closed. Install the waterproof cable glands in each of the openings.

6.5 – Propulsion

Although initially we expected to be responsible for the propulsion system, the manufacturing team eventually took charge of the subsystem.

6.6 – Maintenance and Repair

The original plans for the maintenance and repair of SAVER are listed below. However, these concerns never were an issue for us, as our manufacturing process did not develop this far.

- Should any electronics become exposed to water, they will be immediately powered off and dried. If damage is already done, then we will have to consider looking into third party maintenance assistance or alternative ways to test the design without that specific component. Great care will be taken to avoid this possibility, however.
- Some maintenance wear concerns, especially for the battery, threads, coatings, and gaskets, may be assumed negligible for the span of time that we will be working on the device. It would take years for these to deteriorate, but theoretically they would be able to be replaced over time with the current materials used.

6.7 – Safety

The main safety hazards on this vehicle originally included potential pinch-points, potential electric shock, and impact with the SAVER vehicle. However, the only risk that we faced over the course of this project was potential electric discharge, as the other concerns related to manufacturing operations, or fell under the scoop of the hull and payload team.

The safety of the customer has been addressed earlier in this document, however the safety of the manufacturers and testers has not. In order to keep us safe from manufacturing injuries, appropriate measures were taken. All manufacturing involved minimal use of electronic tools, and those that did require it (such as soldering) were done with the company of someone in their living space in a well-ventilated area, with appropriate measures and awareness being practiced avoiding cuts and burns. As is good practice in any workspace, devices were not left running unattended, and alertness of the person performing the operation was considered paramount.

6.8– Cost

As far as monetary cost, the mechatronic components of SAVER required approximately \$700. Each SAVER team was allocated \$500 from Cal Poly, and the combined cost of both SAVER teams did not exceed \$1000. We (the mechatronics team) were allowed to use some funds from the payload team because the cost of the electronic hardware we needed was substantially more expensive than the raw materials and off-the-shelf components required by the payload team.

7 – Design Verification

This chapter describes how the SAVER Navigation and Controls will test the final design and how the results of these tests were to be interpreted. Additionally, it will lay out the testing procedure used for each specification as well as the processes for performing, documenting, and validating each test.

7.1 Bearing System

This subsystem refers to the long-range detection system of navigating via the signals emitted by the beacon. This comprises of three main stages, direction finding, obtaining position, and triangulation. The results of testing these criteria are summarized in the following sections.

7.1.2 – Direction Finding

The KerberosSDR device was the central equipment of the first test we performed. In order for the whole of SAVER to work properly, the Kerberos must be able to reliably measure the bearing to the distress beacon within $\pm 5^\circ$. This will allow for the triangulation software to still get a reasonable data set to pinpoint the beacon location. The first test involving the Kerberos is the bearing test that will prove whether it falls within the specified tolerance. With the beacon placed in the middle, data points were taken from the Kerberos at known angles and compared to the outputted data. The data from the Kerberos is read off of the direction of arrival graph shown in Figure 7.1.

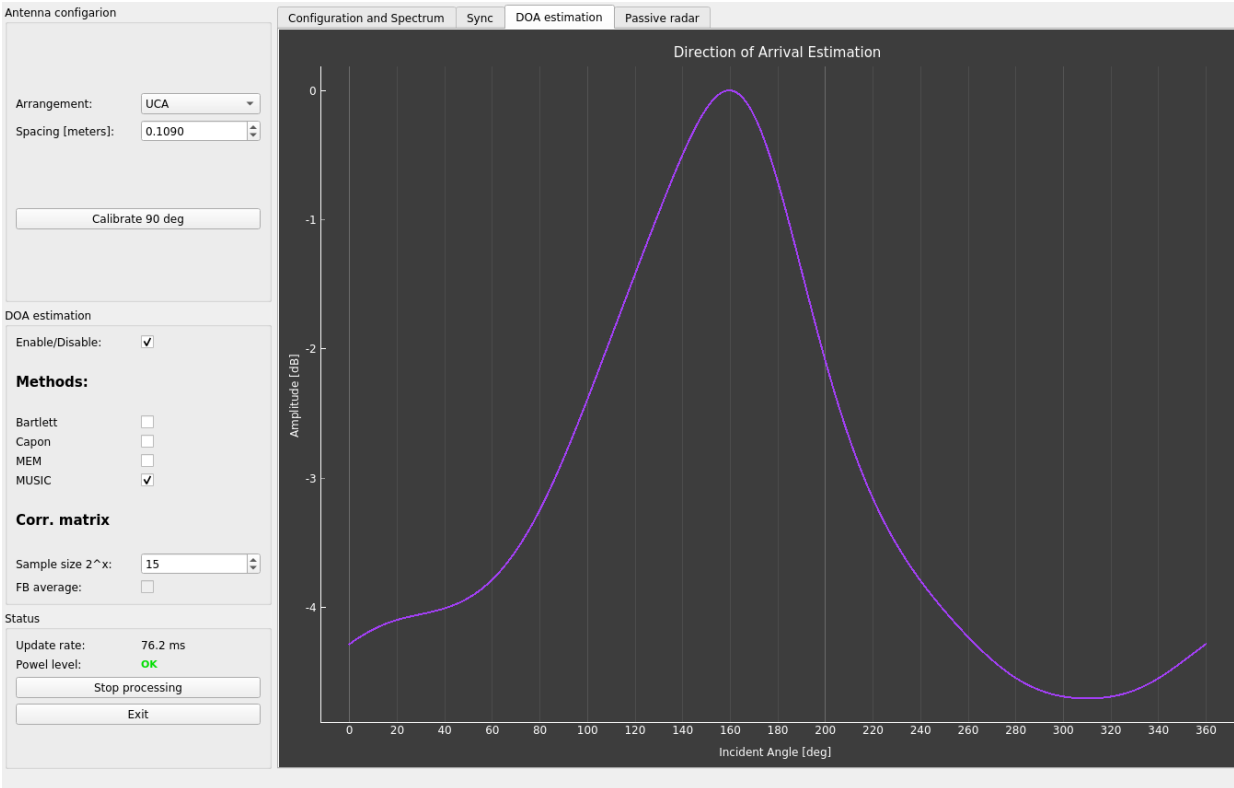

Figure 7.1. Window output from the KerberosSDR software with bearing on the x-axis and signal strength on the y-axis. This allows us to estimate the bearing, which is represented at the peak of this graph.

The Kerberos is very sensitive to interference from the beacon signal bouncing off large objects like buildings and will greatly affect the data during tests, making large open fields as the test location critical. An important discovery was found while conducting this test. Because the Kerberos is a hobbyist product for introduction into radio direction finding, the bearing tolerances were much higher than expected. So much, in fact, that the data taken during the test was extremely random and inconclusive. There is a chance that this could have also been caused by the signal strength of the beacon, but due to money and time restraints, that possibility could not be tested further. The findings from this test will be discussed further in later sections due to the impact on the prototype.

7.1.2 – Positioning System

Another specification that was tested was the ability of SAVER to identify, track, and update the current GPS location of the device. This test was performed by taking the SAVER device, integrated with the Adafruit Ultimate GPS module, into the Cal Poly recreational fields. The device was then powered on, attached to a laptop computer, and moved to several locations throughout the field. At each of these locations, the latitude and longitude location output from the GPS module was recorded with the laptop; additionally, a smartphone was used to record the GPS location at each of these points. Figure 7.2 shows these points on a latitude/longitude plot.

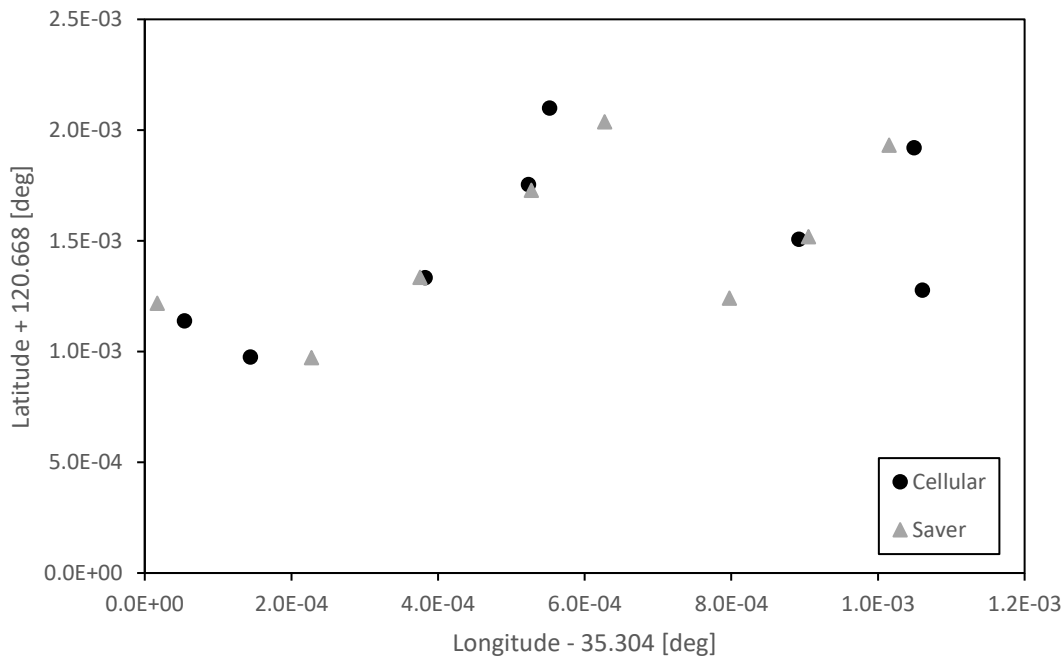

Figure 7.2. – GPS location data gathered from both a cellular device, and SAVER.

The largest disparity, excluding one outlier, was at 31 feet and the smallest measuring two feet. We suspect that the variance is primarily due to the method used to obtain a GPS location from the cellphone, which introduced a degree of human error in placing a pin on the map. Given this data we are comfortable asserting the GPS location will be satisfactory.

7.1.3 – Triangulation

The final test involving the Kerberos tests the beacon tolerance along with the triangulation software. The software compares the intersecting points of the bearing lines as SAVER would move along a path. Complex point cloud analysis tries to find the location of the beacon within a 20-foot radius. Similar to the bearing test, the Kerberos is used to collect data at known points compared to the beacon and locating is performed as each one of the data collections points. Due to time constraints and complications with other aspects of the prototype, only a basic version of the triangulation software could be created and tested via visual inspection. Due to the inaccuracy of the Kerberos, the software could not get a reasonable estimation for the beacon. When reasonable data is given to the software, it can get estimate the beacon location within a 30 to 50-foot range, showing that it does work as intended. Figure 7.3 shows the window output by the triangulation software.

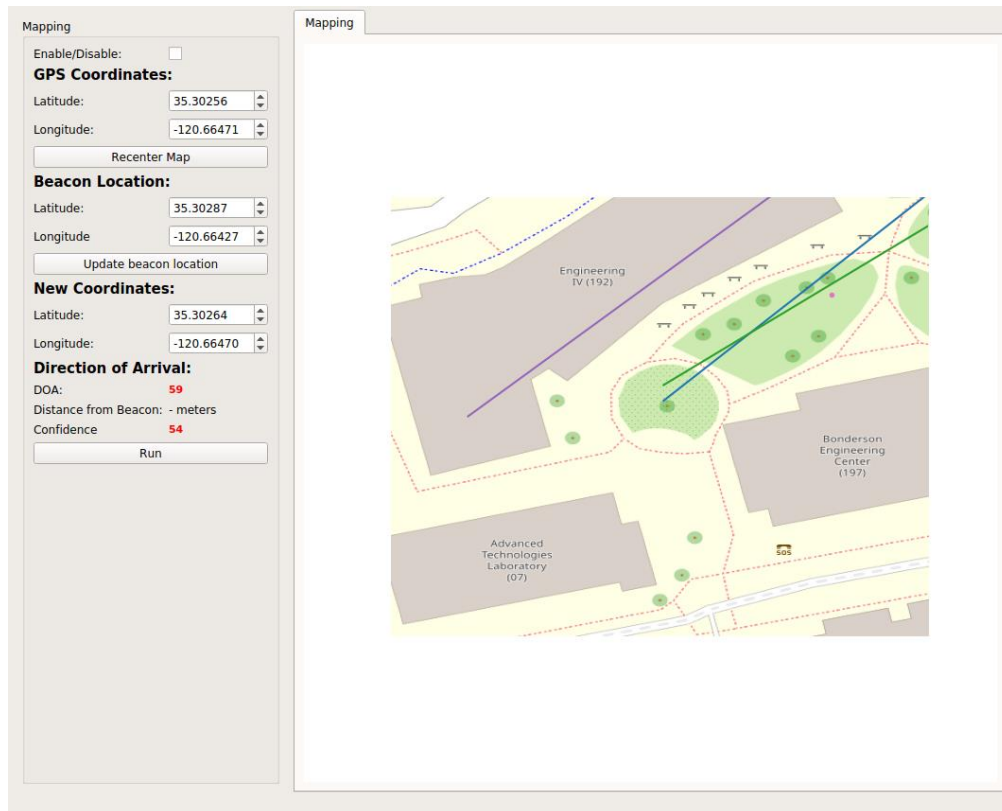

Figure 7.3. Mapping and triangulation software output. The intersecting lines show the possible beacon position while the red dot is the actual position.

7.2 – Visual System

This section contains the testing procedures used to evaluate the efficacy of our close-range navigation system by conducting tests on its two major components – object detection and depth mapping. Since this system is designed activate when we start to approach the target the tests are geared toward ranges within 100 feet. The results of testing these two components are summarized in sections 7.2.1-7.2.2.

7.2.1 – Object Detection

As described in the final design, the detection network we are using analyzes each frame, and outputs the bounding box of any known objects, along with the how confident it is in that categorization. To get a better understanding of how well the system is able to pick a person out of an image, we programmed the system to output both the number of frames in which the device obtained a successful detection out of the past 100 frames, and the average confidence of these detections. The results of testing this program at 10 ft increments is summarized in Table 7.1 and plotted in Figure 7.4.

Table 7.1. Object Detection Raw Data

Distance [ft.]	Consistency [%]	Confidence [%]
10	100	97
20	96	100
30	100	69
40	100	47
50	96	33
60	20	24
70	0	-
80	0	-
90	0	-
100	0	-

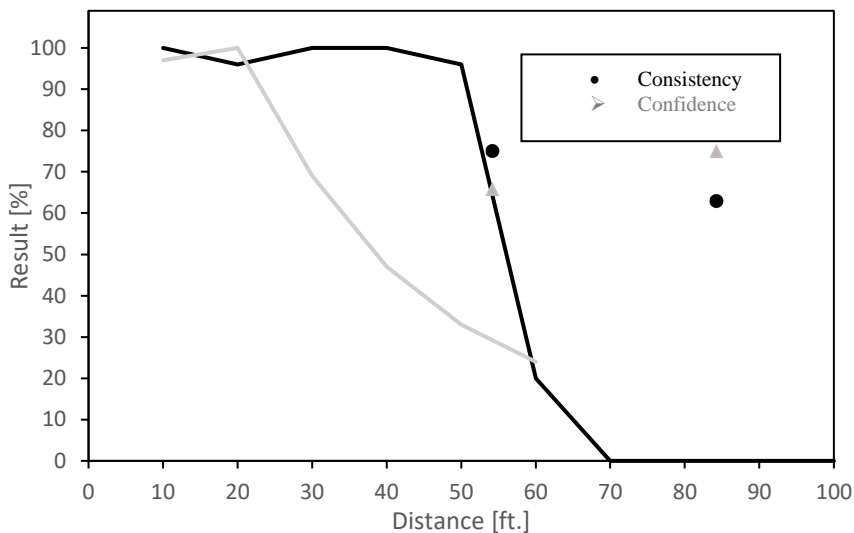

Figure 7.4. Detection consistency and confidence at various distances.

The most striking part of this data is the way the consistency rapidly drops to 0 after about 50 feet. This however is made clear when considering that this neural network requires that we set a minimum confidence in order for a detection to be triggered. For this run the minimum confidence was set at 20%. Therefore, we can conclude that while at 60 feet, the average confidence was 24%, 80 of those frames fell below the detection threshold. After 60 feet, all confidence fell below 20% resulting in no detections.

For our application, these results are pleasing. The cameras are able to detect a human in almost all frames when within 50 feet, at an average confidence of 33%. This is well within our benchmark of 50% consistency at 25% confidence. After this the confidence drops below our desired levels, but overall, this test has proved the detection system to be effective.

It is worth noting that while conducting this test, we saw the confidence change significantly when the target assumed certain positions. For example, confidence jumped to nearly 100% at 30 feet when the target raised their arms. It is also worth noting that confidence dropped when the lighting put a dark body against a dark background. Fortunately, in the open ocean, contrast will likely be high.

7.2.2 – Depth Mapping

The second part of this system is the depth mapping, which takes the input from two separate cameras mounted horizontally and compares them to calculate depth. After the distortion is removed from the images, the software compares the edges and features present in each photo to calculate a disparity and uses this disparity alongside the focal length of the lens, and the distance between the cameras to calculate a distance. The output of this program can be visualized with a map where brightness indicated depth. One such map is illustrated in Figure 7.5

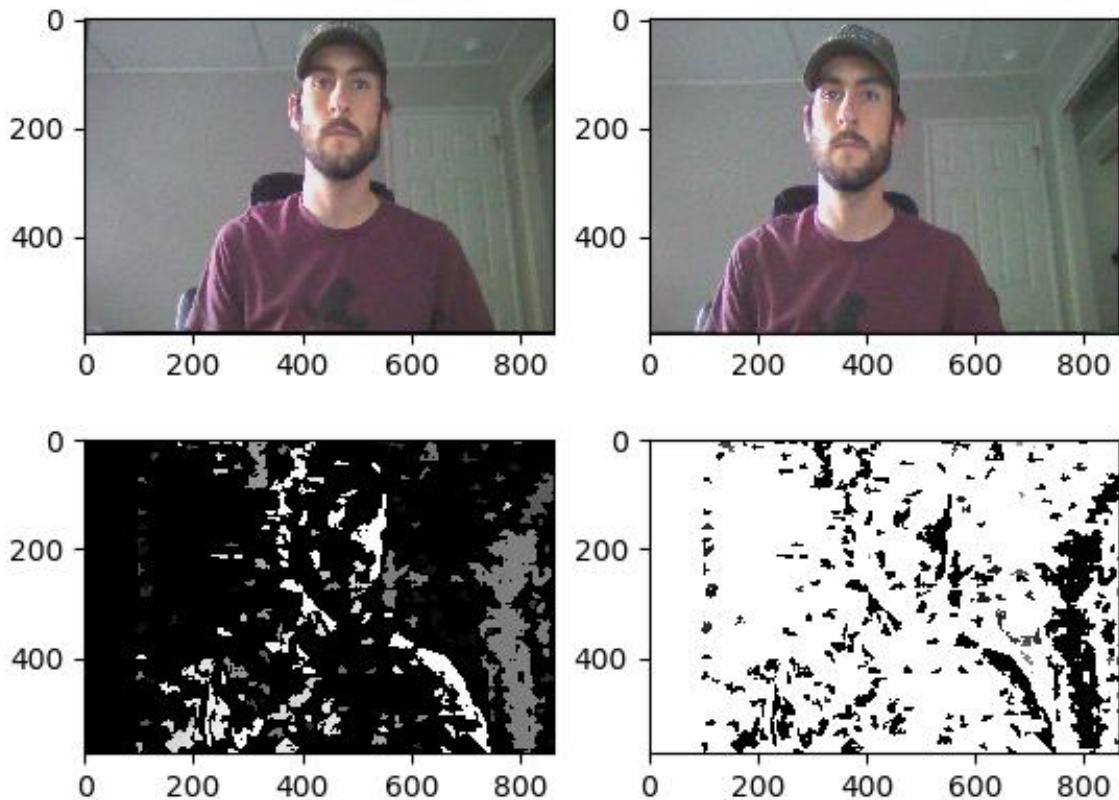

Figure 7.5. – Stereo camera outputs (top) along with the calculated disparity (bottom left) and subsequently estimated depth map (right).

Unfortunately, this process has proven more complex than anticipated and has not yielded reliable results. As seen in the figure, while the edges appear to be working, the map is dominated by gaps. Many hours were spent tuning the individual parameters of this algorithm, but none yielded a more favorable result. The complications appear to be a combination of hardware

limitations, and a deep level of software integration that is beyond the scope of our project. However, this project has succeeded in proving the viability of using object recognition in conjunction with depth mapping for our application, as the two ran together successfully. This code can be found as “main2.py” within the Visual System folder. As we will discuss in the conclusion, the knowledge we have obtained has allowed us to identify proprietary hardware/software packages that could be used by a future team if they choose to pursue this route.

8 – Project Management

This section details how we organized tasks and delegated responsibilities, as well as laying out our plans to transfer our hardware to next year's SAVER team.

8.1 – Overview

The bulk of this project ended up being focused on research and development of the critical components that will be needed to help next years' team succeed. The implementation of radio beacon finding was a much bigger challenge than we ever anticipated, and although the KerberoSDR performed well, it was not able to perform at a high enough resolution needed for the competition. Similarly, the stereo camera depth mapping and identification was a large challenge for us. Although we saw some promising results, the amount of time needed to create a fully integrated prototype with all of the subsystems operational proved to be unattainable this year. Overall, we learned a lot about the underlying technologies needed to succeed in competition, and the work that we have done will serve as a valuable proof-of-concept for next year's team.

8.2 – Testing

The testing we performed was ongoing and adaptive, rather than performed all at once. Systems like the stereo camera depth mapping and KerberoSDR range finding required lots of fine tuning, and as such were tested in a variety of different configurations over the course of spring quarter. However, we were never able to achieve fully satisfactory results from these tests, largely due to the limited capabilities of such a low-cost system, and the complexity of such components. Ultimately, we hope that what we have learned from our testing will be a useful resource for next years' SAVER team. A full description of the testing performed is available in Appendix H.

8.3 – Future of the Project

The 2020-2021 SAVER team will be transferring all of our hardware, software, and documentation to the next Cal Poly SAVER team, starting in Fall 2021. We hope that the knowledge we have gathered throughout this past year will be put to good use in the future and help the next team towards success.

9 – Conclusions and Recommendations

The SAVER Electronics team was able to create workable subsystems for the radio direction finding, proximity detection, and power distribution, but compiling them into a coherent prototype proved to be more difficult than expected. At the time of the projects downscale, we were unaware that proceeding with cheaper products meant more custom software would have to be produced to get them to work for SAVER. Instead of reducing the project size, the downscale greatly increased the scope of the project beyond the bounds of our formal education, dipping into the realm of software engineering. By the time these conditions were realized, our budget was nearly gone, and time was dwindling, so we had to proceed and produce what we could with the resources acquired. Much of our time was lost producing and debugging code for the subsystem processes, leaving no time to produce software that could integrate all the parts. In the end, we are happy with strides made during this project and the lessons learned, even though the final system was not fully completed. The subsystems will allow future teams to have working devices to learn from along with the advice and research from the current SAVER team. All of us gained experience with the vast range of topics intertwined in this project, but arguably the most important lesson was pushing through unexpected difficulties that come from the design process.

9.1 – Recommendation for Direction Finding

A myriad of discoveries was found when researching direction finding antenna systems and working with the KerberosSDR. If the SAVER project is to stay within the scope of mechanical engineering at Cal Poly, the only option to achieve the resolution needed for the device to work properly would be buying a third-party antenna system that comes with software. Otherwise, the team needs a group of software and electrical engineers to work with because the technical education needed to produce such systems are not encompassed in the ME degree. The custom software needed to get SAVER working Advanced antenna systems used for direction finding can cost upwards of \$10,000 or more due to the accuracy they can produce and the proprietary software they come with. The Kerberos does come with some software, but the accuracy of the system falls short of specification for SAVER. It is a product that is more geared towards radio hobbyists, rather than something that can be used for engineering purposes. That

being said, the Kerberos is a phenomenal learning tool and will allow future teams to introduce themselves with radio direction finding technology.

9.2 – Recommendation for Proximity Detection

There were two subprocesses within the proximity detection: the image recognition and depth mapping. The NVIDIA powered AI image recognition that comes with the Jetson found us great success in its capabilities. It was able to pick up a human out of the water within 50-feet, and we believe that with more calibration, it could easily find an astronaut in the water for SAVER. Overall, we would recommend the Jetson Nano and AI software for object detection regardless of the method used for finding the distance to the target.

The depth mapping with stereo cameras, on the other hand, is a more complicated story. We focused mostly on using OpenCV's block matching to achieve our goals, and many hours were spent trying to dial in parameters to no avail. There are however other programs that might be worth investigating, however, it is very difficult to say how accurate they will be until significant time is sunk into them. Overall, we recommend using a product specifically designed for stereo vision, or finding a way to utilize a more conventional distance measuring system.

Works Cited

- Ari, et al. *Water Environment Mobile Robot*. JP 2018514433 A, Japan Patent Office, 7 June 2018. *Google Patents*, patents.google.com/patent/JP2018514433A/en.
- Baird, Danny, and Lynn Jenner. "NASA Develops Second-Generation Search and Rescue Beacon Technology." *NASA*, 3 Dec. 2019, www.nasa.gov/feature/goddard/2019/nasa-develops-second-generation-search-and-rescue-beacon-technology.
- Baughman, David C. *Tracking of Autonomous Systems*. US 7948439 B2, United States Patent and Trademark Office, 24 May 2011. *Google Patents*, patents.google.com/patent/US7948439B2/en.
- "COLREGs." *International Maritime Organization*, 20 Oct. 1972, www.imo.org/en/About/Conventions/ListOfConventions/Pages/COLREG.aspx.
- Deglinnocenti, Marc. "Marine Autonomous Vehicles and the Law: Assessing Risks and Liability." *Professional Mariner*, 1 June 2018, www.professionalmariner.com/marine-autonomous-vehicles-and-the-law-assessing-risks-and-liability/.
- "Freefall Lifeboat." *Survitec*, survitecgroup.com/survitecproducts/14767/FreefallLifeboat.
- Hambling, David. "The Military's Weapon-Carrying, Terrorist-Spotting Autonomous Jet Ski." *Popular Mechanics*, 24 Nov. 2010, www.popularmechanics.com/military/a6273/the-militarys-autonomous-jet-ski/.
- Hansen, Eric C. *Overboard Rescue System*. US 6558218 B1, United States Patent and Trademark Office, 6 May 2003. *Google Patents*, patents.google.com/patent/US6558218B1/en.
- "HS-PS2-3 Motion and Stability: Forces and Interactions." *Next Generation Science Standards*, www.nextgenscience.org/pe/hs-ps2-3-motion-and-stability-forces-and-interactions.
- Huber, Braden Russell. *Radio Determination on Mini-UAV Platforms: Tracking and Locating Radio Transmitters*. 2009. Brigham Young University, Master's Thesis. *BYU ScholarsArchive*, scholarsarchive.byu.edu/cgi/viewcontent.cgi?referer=&httpsredir=1&article=2742&context=etd.
- Huelsmeyer, Christian. *Hertzian-Wave Projecting and Receiving Apparatus Adapted to Indicate or Give Warning of the Presence of a Metallic Body, such as a Ship or a Train, in the Line of Projection of such Waves*. GB 190413170 A, Intellectual Property Office, 22 Sep. 1904. *Google Patents*, patents.google.com/patent/GB190413170A/en.

Huelsmeyer, Christian. *Improvement in Hertzian-Wave Projecting and Receiving Apparatus for Locating the Position of Distant Metal Objects*. GB 190413170 A, Intellectual Property Office, 22 Sep. 1904. *Google Patents*, patents.google.com/patent/GB190425608A/en.

“Key Features - EMILY - Robotic Rescue Boat.” *Hydronalix*, www.emilyrobot.com.au/key-features.

Kukulya, Amy L., et al. *System and Method for Autonomous Tracking and Imaging of a Target*. US 20180082166 A1, United States Patent and Trademark Office, 22 Mar. 2018. *Google Patents*, patents.google.com/patent/US20180082166A1/en.

Mazucca, Lisa, and Cody Kelly. “Advanced Next-Generation Emergency Locator (ANGEL) MEOSAR Applications to NASA Human Spaceflight.” *NASA*, 21 June 2016, ntrs.nasa.gov/citations/20160007847.

“Micro-g NEXt 2021 Design Challenges.” *Microgravity University*, 28 Sept. 2020, microgravityuniversity.jsc.nasa.gov/docs/micro-g/2021%20Micro-g%20NEXt%20Challenge%20Descriptions%20v5.pdf.

“NBL Engineering and Safety Requirements for Micro-g NEXt.” *Microgravity University*, 25 July 2019, microgravityuniversity.jsc.nasa.gov/docs/micro-g/NBL-Safety-Requirements.pdf. Accessed 8 Oct. 2020.

Njus, Elliot. “The Military’s Oregon-Built Drone Ship Is Headed to California.” *The Oregonian*, 9 Jan. 2019, www.oregonlive.com/business/2016/04/sea_hunter_the_militarys_orego.html.

“PLB1, the World’s Smallest PLB.” *Ocean Signal*, oceansignal.com/products/plb1/.

“PrecisionVision 35.” *Leading Edge Aerial Technologies*, leaaerialtech.com/product/precisionvision-35.

Pritchard, Philip J. *Fox and McDonald’s Introduction to Fluid Mechanics*. 8th ed., John Wiley & Sons, Inc., 2011.

Rudersdorfer, Ralf, et al. *Radio Receiver Technology: Principles, Architecture and Applications*. John Wiley & Sons, Inc., 2013. doi:10.1002/9781118647882.

Sadler, D. J. “Accuracy of Adcock Watson-Watt DF in the Presence of Channel Errors.” 2019 Sensor Signal Processing for Defence Conference (SSPD), May 2019, Brighton, United Kingdom. pp. 1-5, doi:10.1109/SSPD.2019.8751643.

- Sampson, Ben. "Autonomous Distress Tracking Device Receives FAA Approval." *Aerospace Testing International*, 21 Nov. 2019, www.aerospacetestinginternational.com/news/avionics/autonomous-distress-tracking-device-receives-approved-by-faa.html.
- Shi, Yun-Gang, and He-Wen Wei. "Performance Analysis and Comparison of Correlative Interferometers for Direction Finding." *IEEE 10th International Conference on Signal Processing Proceedings*, Oct. 2010, Beijing, China. pp. 393-396, doi: 10.1109/ICOSP.2010.5657185.
- US Department of Commerce, National Oceanic and Atmospheric Administration. "Remotely Operated Vehicle *Deep Discoverer*." *NOAA*, oceanexplorer.noaa.gov/technology/subs/deep-discoverer/deep-discoverer.html.
- Vallejo, Daniel. "Electric Currents: Programming Legal Status into Autonomous Unmanned Maritime Vehicles." *Case Western Reserve Journal of International Law*, vol. 47, no. 1, 2015, pp. 405-428. *Case Western Reserve University*, scholarlycommons.law.case.edu/jil/vol47/iss1/25.
- "What Is Worst Possible Idea?" *Interaction Design Foundation*, www.interaction-design.org/literature/topics/worst-possible-idea.
- Woodland, Richard L. K. *Autonomous Marine Vehicle*. US 6269763 B1, United States Patent and Trademark Office, 7 Aug. 2001. *Google Patents*, patents.google.com/patent/US6269763B1/en.





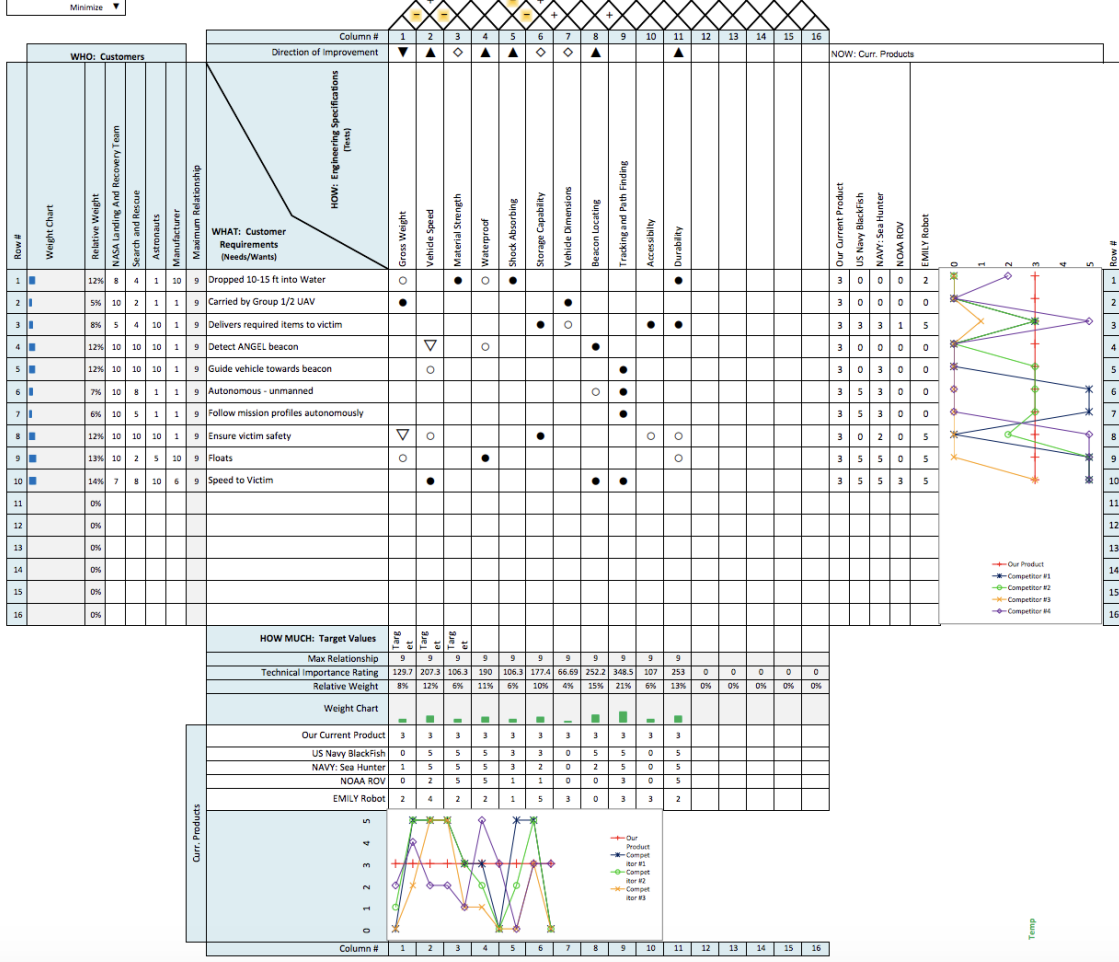

Appendix A: QFD House of Quality

Correlations	
Positive	+
Negative	-
No Correlation	
Relationships	
Strong	●
Moderate	○
Weak	▽
Direction of Improvement	
Maximize	▲
Target	◇
Minimize	▼

QFD House of Quality
 Project: SAVER
 Revision Date: 10/5/2020



Appendix B: Weighted Decision Matrix

SAVER Weighted Decision Matrix		Idea 1		Idea 2		Idea 3		Idea 4		Idea 5		Idea 6		Idea 7	
Design Sketch															
Design Description		A single main hull with sculpted bottom to reduce impact force and stabilized by two outboard pontoons. Propulsion and steering is controlled by two independent outboard propellers. Payload is stored in hollow main hull and accessed through latched lid on top of craft.		Shaped hull optimized for hydrodynamics and entering water from high height. Propulsion consists of electric motor driving jet-ski motor like propeller system with back rudder for steering. Payload located in the front of device for ease access for astronaut. Rest of the device hinges open for maintenance		Shaped hull held shut by side latches. Pontoons and caged dual side propellers control and stabilize system. Payload is external and detachable.		Jet-ski style propulsion with multiple outlets for control and steering. Payload is stored internally and secured from the water with latched hinged lid. The shape of the main hull is shaped to minimize water impact.		Jet-ski nozzle for primary propulsion, small front propeller for low speed maneuvers. Shaped hull with weighted bottom. Top hatch that opens along the longitudinal edge.		Torpedo style body and propulsion with gimble for steering. Interior compartment for payload. Latch for the internal hardware. Two fins for stability.		Torpedo style hull with two winged propellers. Weighted nose to help with impact resistance and separate compartments to isolate electronics from payload. Rear stabilizing foil to help with stability.	
Specification	Weight [ranked]	Score	Weighted Score	Score	Weighted Score	Score	Weighted Score	Score	Weighted Score	Score	Weighted Score	Score	Weighted Score	Score	Weighted Score
Weight	0.1	4	0.4	6	0.6	4	0.4	5	0.5	5	0.5	7	0.7	7.5	0.75
Speed	0.075	6	0.45	8	0.6	6	0.45	7	0.525	8	0.6	9	0.675	7	0.525
Shell Impact Absorption	0.1	8	0.8	8	0.8	9	0.9	6	0.6	9	0.9	10	1	7	0.7
Electronics Impact Absorption	0.1	6	0.6	8	0.8	7	0.7	6	0.6	7	0.7	8	0.8	7	0.7
Cost	0.05	6	0.3	7	0.35	6	0.3	4	0.2	3	0.15	5	0.25	8	0.4
Manufacturability	0.075	5	0.375	8	0.6	8	0.6	3	0.225	6	0.45	3	0.225	8	0.6
Manuverability	0.1	9	0.9	5	0.5	7	0.7	5	0.5	8	0.8	3	0.3	8	0.8
Payload Accessibility	0.125	9	1.125	7	0.875	10	1.25	9	1.125	8	1	7	0.875	6	0.75
Internal Hardware Isolation	0.1	8	0.8	8	0.8	8	0.8	8	0.8	8	0.8	8	0.8	7	0.7
Safety	0.175	8	1.4	9	1.575	8	1.4	6	1.05	8	1.4	6	1.05	7	1.225
Total	1		7.15		7.5		7.5		6.125		7.3		6.675		7.15

Appendix C: Preliminary analysis

Initial Navigation Simulation Pseudocode

```
1  ///Navigation Pseudocode
2  /*
3
4  import kerberos example library
5
6  trigset = -1
7  bearings = list
8  distances = list
9  lat = list #for storing latidue data
10 long = list #for storing longitude data
11
12 define a function DF() (direction finding) for calculating bearing from phase data
13     **
14     **
15     return bearing
16
17
18 define a function gpsLen(lat1,long1,lat2,long2)
19     return distance in meters between the two latitude longitude sets
20
21
22 if we have received a pulse from the beacon
23
24     trigset += 1
25
26     receive phase data from antennas p1, p2, p3, p4
27     append the results of the DF function on (p1,p2,p3,p4) to the bearings list
28
29     receive positional data from GPS
30     append latitude/longitude to lists
31
32     if trigset >= 1
33         #get the angle between position(trigset) and positions(trigset-1)
34         phi = arctan((long[trigset]-long[trigset-1])/(lat[trigset]-lat[trigset-1]))
35         ang_A = bearings[trigset-1] - phi
36         ang_B = 180 + phi - bearings[trigset]
37         ang_C = 180 - ang_A - ang_B
38         len_c = gpsLen(lat[trigset],long[trigset],lat[trigset-1],long[trigset-1])
39
40         #finally calculate the length of a, which is the current distance fom SAVER the
41         # beacon, using the law of sines,
42
43         len_a = arcsin(sin(ang_A)*len_c/sin(ang_A))
44         distances.append(len_a)
45
46         #calculate uncertainty
47         calculate propogation of uncertainty based on A, C and c
48
```

Appendix D: Drawing Package and Specifications Sheets

SAVER Mechatronics Indented Bill of Materials:

SAVER 2 Indented Bill of Material (iBOM)											
Assembly Level	Part Number	Description					Qty	Cost	Ttl Cost	Source	More Info
		Lvl0	Lvl1	Lvl2	Lvl3	Lvl4					
0	10000		SAVER								
1	12000			SAVER 2							
2	12100				Microcontroller						
3	12110				NVIDIA Jetson (V3)		1	99.99	99.99	Sparkfun Item: DEV-16271 RoHS	
2	12200				Direction Finding						
3	12210				Antennas		4	12.32	49.28	Digikey.com Part number: 2626-AN_GSM_016-ND	
3	12220				Kerberos System		1	299.99	299.99	Othernet.is Item name: KerberosSDR	
2	12300				Camera system						
3	12310				Stereo Cameras		1	44.99	44.99	Waveshare.com SKU: 17742	
2	12400				Propulsion System						
3	12410				Thrusters		2	49.99	99.98	Amazon.com https://www.amazon.com/Underwater-Thruster-Brushless-Propeller-Submarine/dp/B08CMYFBFBF/ref=sr_1_4?dchild=1&keywords=boat+thruster&qid=1611135382&sr=8-4	
					Thruster Nuts		8			M3 nuts, came with purchase of thrusters	
					Thruster Bolts		8			M3 bolts, came with purchase of thrusters	
2	12500				Power System						
3	12510				Speed Controller		2	39.99	79.98	Amazon.com https://www.amazon.com/2TV-Brushless-Controller-Helicopter-Connector/dp/B0747S1F2F/ref=pd_bxgw_img_2?i38=2680271-8120334?_encoding=UTF8&pd_rd_i=B07QNM05C3&pd_rd_r=1ce5b3e0-5a8b-4404-b290-6cc91482524a&pd_rd_w=L6SR9&pd_rd_wg=5mw53&pf_rd_p=f325d01c-4650-4593-ba93	
3	12520				Lipo Battery		1	98.99	98.99	Amazon.com https://www.amazon.com/2eee-7000mAh-Battery-Connector-Traxxas/dp/B07YF7MT8V/ref=pa_2?i38=2680271-8120334?_encoding=UTF8&pd_rd_i=B07YF7MT8V&pd_rd_r=81b6a802-0424-439d-a4d8-8fed2f6bc3ab&pd_rd_w=ballF&pd_rd_wg=X0S6Z&pf_rd_p=16b28406-aa34-451d-8a2e	
3	12530				Lipo Charger		1	39.99	39.99	Amazon.com https://www.amazon.com/Charger-Battery-Balance-Discharger-Li-ion/dp/B08C592PNW/ref=sr_1_4?dchild=1&keywords=lipo+battery+charger&qid=1612467387&sr=toys-and-games&sr=1-4	
3	12540				Battery eliminating circuit		2	8.99	17.98	racedayquads.com https://www.racedayquads.com/products/matek-micro-bec-8-30v-input-to-5v-12v-adjustable-3pcs?variant=19818571989105&currency=USD&qid=Cj0KCQiA34QBhCgAFIeAG32uvPTOhdTnhHAG2EhBEkshL87483v7GjI2YY--ZTUth	
Total Parts							25		831.17		

Drawing Package for Manufactured and Altered Parts:

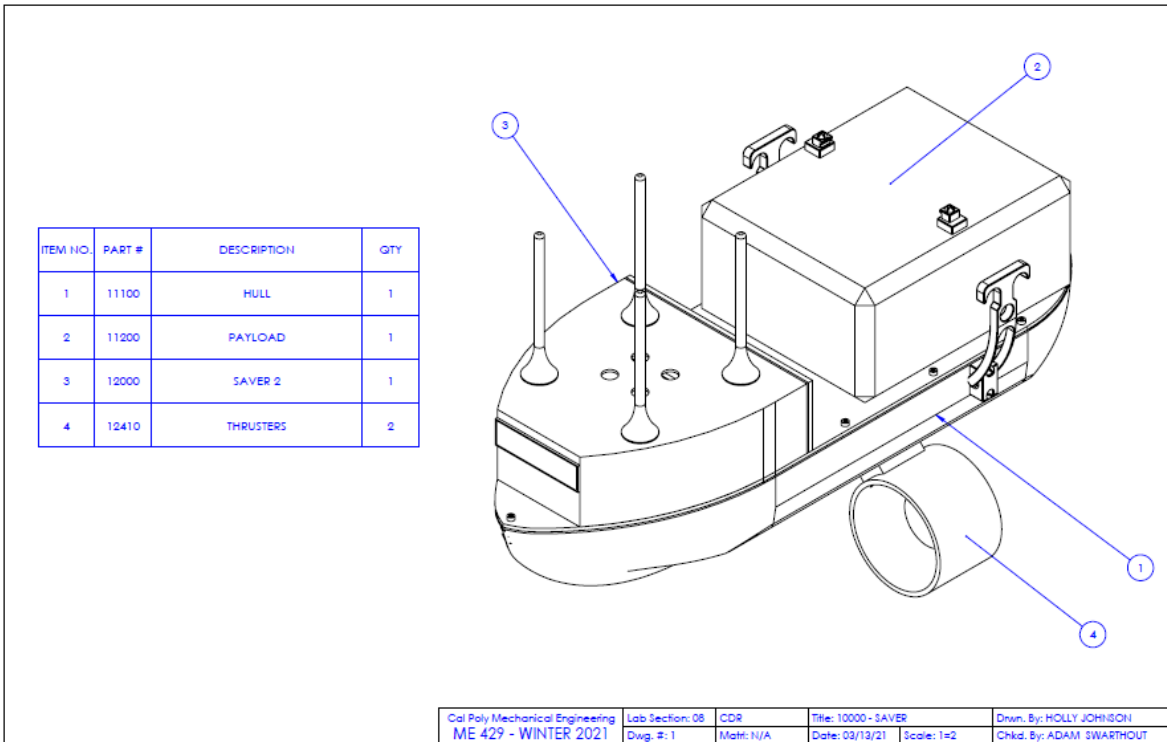

SOLIDWORKS Educational Product. For Instructional Use Only.

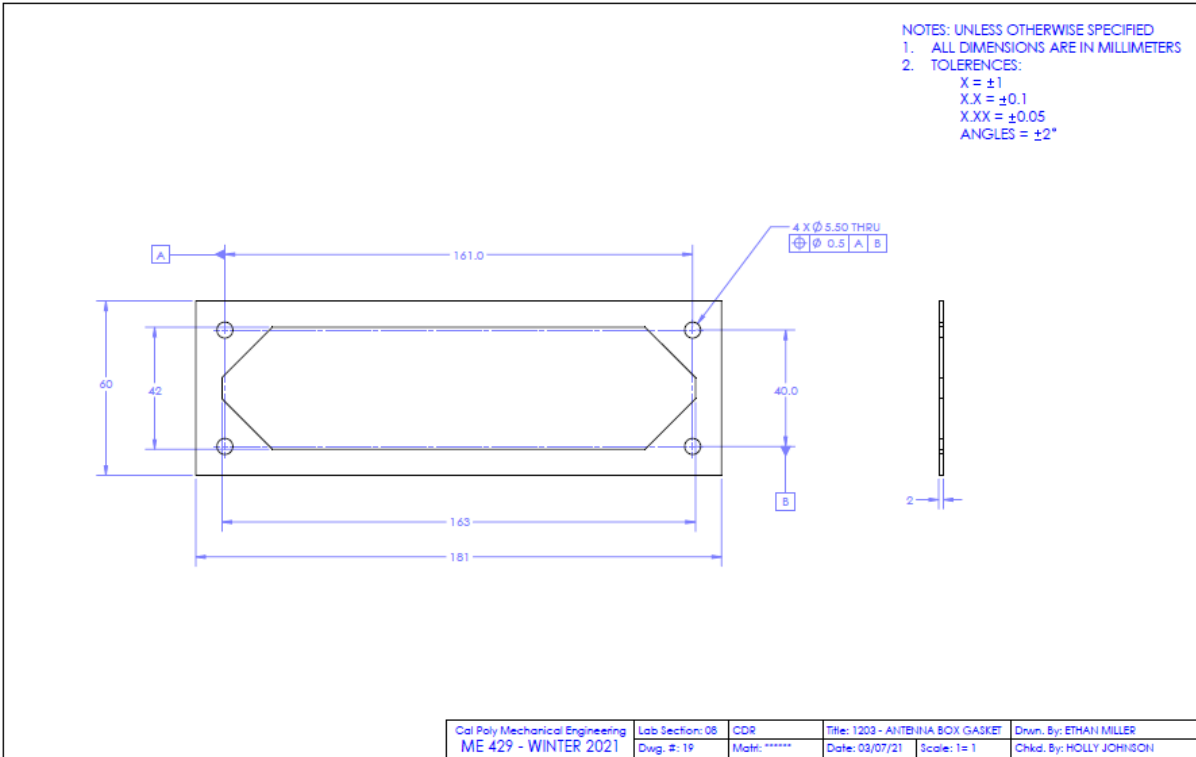

SOLIDWORKS Educational Product. For Instructional Use Only.

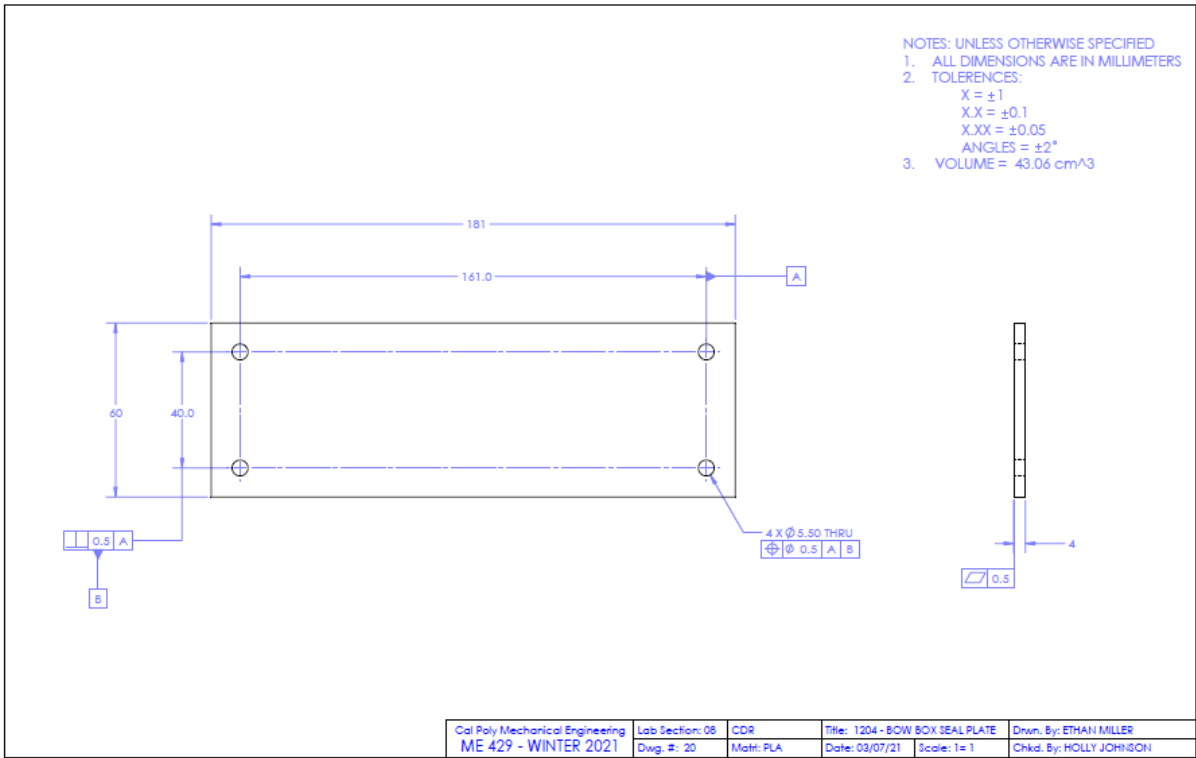

SOLIDWORKS Educational Product. For Instructional Use Only.

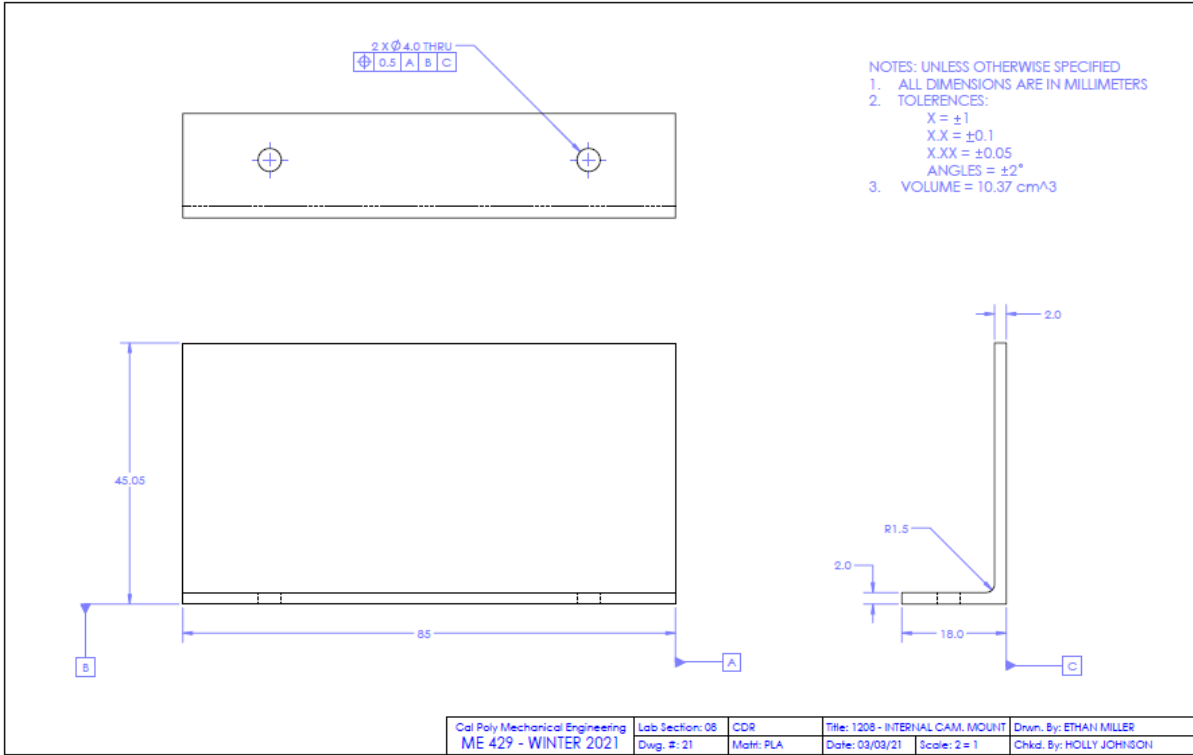

SOLIDWORKS Educational Product. For Instructional Use Only.

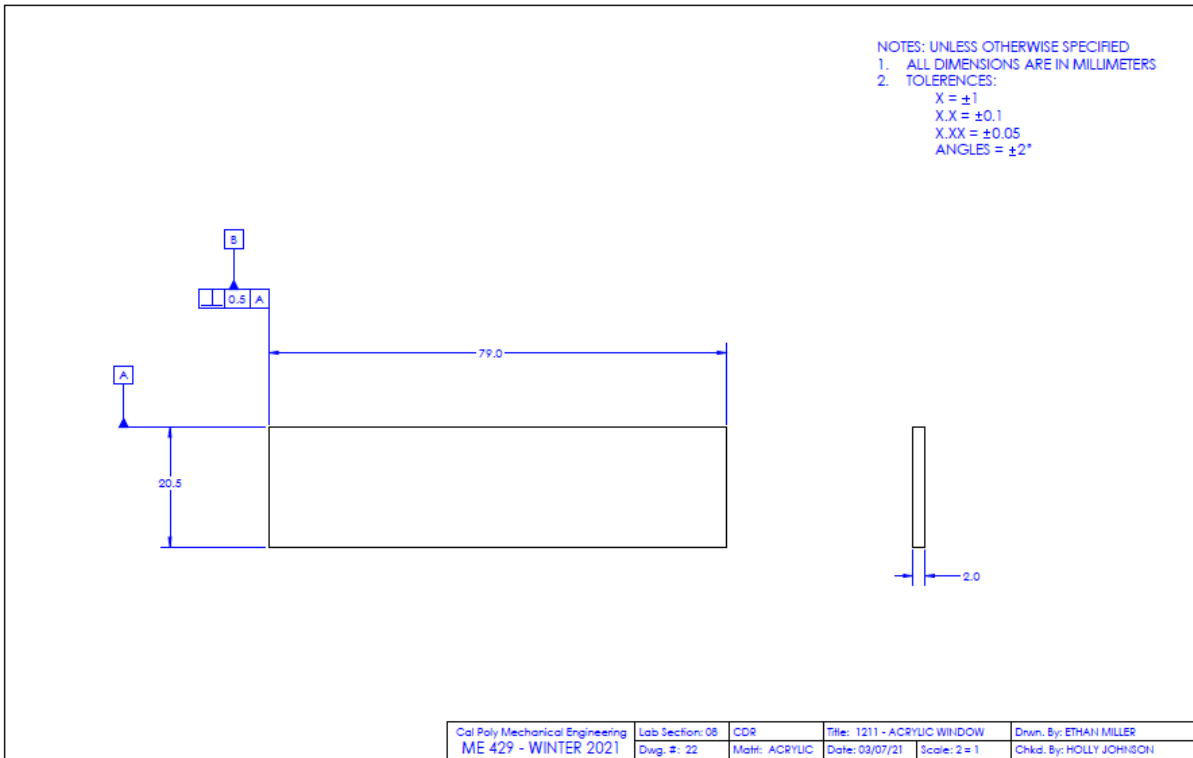

SOLIDWORKS Educational Product. For Instructional Use Only.

Wiring Diagram:

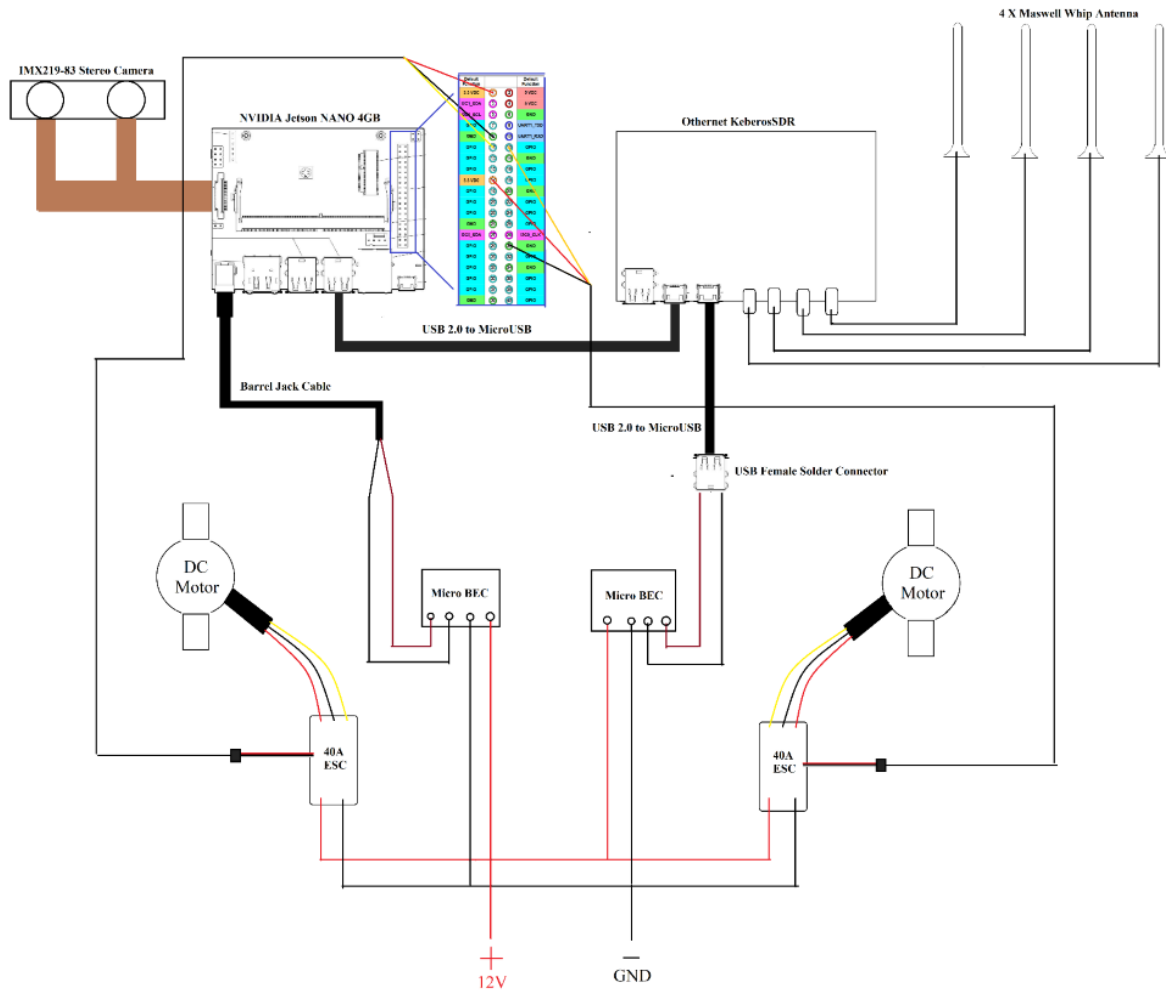

Specifications Sheets:

1. NVIDIA Jetson
2. KerberosSDR
3. Maswell Whip Antenna
4. IMX219-83 Stereo Camera
5. iFlight Micro BEC (Battery Eliminating Circuit) 5V 3A
6. Yuenhoang 12V Underwater Thruster
7. Myswift ESC (Speed Controller) 40A

(1) NVIDIA Jetson Specification Sheet:

Join the Revolution and Bring the Power of AI to Millions of Devices

The NVIDIA® Jetson Nano™ Developer Kit delivers the compute performance to run modern AI workloads at unprecedented size, power, and cost. Developers, learners, and makers can now run AI frameworks and models for applications like image classification, object detection, segmentation, and speech processing.

The developer kit can be powered by micro-USB and comes with extensive I/Os, ranging from GPIO to CSI. This makes it simple for developers to connect a diverse set of new sensors to enable a variety of AI applications. It's incredibly power-efficient, consuming as little as 5 watts.

Jetson Nano is also supported by NVIDIA JetPack™, which includes a board support package (BSP), Linux OS, NVIDIA CUDA®, cuDNN, and TensorRT™ software libraries for deep learning, computer vision, GPU computing, multimedia processing, and much more. The software is even available using an easy-to-flash SD card image, making it fast and easy to get started.

The same JetPack SDK is used across the entire NVIDIA Jetson™ family of products and is fully compatible with NVIDIA's world-leading AI platform for training and deploying AI software. This proven software stack reduces complexity and overall effort for developers.



KEY FEATURES

Jetson Nano Module

- > 128-Core NVIDIA Maxwell™ GPU
- > Quad-Core ARM® A57 CPU
- > 4 GB 64-Bit LPDDR4
- > 10/100/1000BASE-T Ethernet

Power Options

- > Micro-USB 5V 2A
- > DC Power Adapter 5V 4A

I/O

- > USB 3.0 Type A
- > USB 2.0 Micro-B

- > HDMI/DisplayPort
- > M.2 Key E
- > Gigabit Ethernet
- > GPIOs, I²C, I²S, SPI, UART
- > MIPI-CSI Camera Connector
- > Fan Connector
- > PoE Connector

Kit Contents

- > NVIDIA Jetson Nano Module with Heatsink and Reference Carrier Board
- > Quick Start Guide and Support Guide

NVIDIA JETSON NANO DEVELOPER KIT | DATA SHEET | JAN20

NVIDIA JETSON NANO DEVELOPER KIT

TECHNICAL SPECIFICATIONS

DEVELOPER KIT

GPU	128-Core Maxwell
CPU	Quad-Core ARM A57 @ 1.43 GHz
Memory	4 GB 64-bit LPDDR4 25.6 GB/s
Storage	microSD (Not Included)
Video Encoder	4K @ 30 4x 1080p @ 30 9x 720p @ 30 (H.264/H.265)
Video Decoder	4K @ 60 2x 4K @ 30 8x 1080p @ 30 18x 720p @ 30 (H.264/H.265)
Camera	2x MIPI CSI-2 DPHY lanes
Connectivity	Gigabit Ethernet, M.2 Key E
Display	HDMI 2.0 and eDP 1.4
USB	4x USB 3.0, USB 2.0 Micro-B
Others	GPIO, I ² C, I ² S, SPI, UART
Mechanical	100 mm x 80 mm x 29 mm

*Please refer to NVIDIA documentation for what is currently supported.

SoC GPIO	Linux GPIO #	Alternate Function	Default Function			Default Function	Alternate Function	Linux GPIO #	SoC GPIO
			3.3 VDC	①	②	5 VDC			
PJ.03	75	GPIO	I2C1_SDA	③	④	5 VDC			
PJ.02	74	GPIO	I2C1_SCL	⑤	⑥	GND			
PBB.00	216	AUD_CLK	GPIO	⑦	⑧	UART1_TXD	GPIO	48	PG.00
			GND	⑨	⑩	UART1_RXD	GPIO	49	PG.01
PG.02	50	UART1_RTS	GPIO	⑪	⑫	GPIO	I2S0_SCLK	79	PJ.07
PB.06	14	SPI1_SCK	GPIO	⑬	⑭	GND			
PY.02	194		GPIO	⑮	⑯	GPIO	SPI1_CS1	232	PDD.00
			3.3 VDC	⑰	⑱	GPIO	SPI1_CS0	15	PB.07
PC.00	16	SPI0_MOSI	GPIO	⑲	⑳	GND			
PC.01	17	SPI0_MISO	GPIO	㉑	㉒	GPIO	SPI1_MISO	13	PB.05
PC.02	18	SPI0_SCK	GPIO	㉓	㉔	GPIO	SPI0_CS0	19	PC.03
			GND	㉕	㉖	GPIO	SPI0_CS1	20	PC.04
PB.05	13	GPIO	I2C0_SDA	㉗	㉘	I2C0_CLK	GPIO	18	PC.02
PS.05	149	CAM_MCLK	GPIO	㉙	㉚	GND			
PZ.00	200	CAM_MCLK	GPIO	㉛	㉜	GPIO	PWM	168	PV.00
PE.06	38	PWM	GPIO	㉝	㉞	GND			
PJ.04	76	I2S0_FS	GPIO	㉟	㊱	GPIO	UART1_CTS	51	PG.03
PB.04	12	SPI1_MOSI	GPIO	㊳	㊴	GPIO	I2S0_DIN	77	PJ.05
			GND	㊵	㊶	GPIO	I2S0_DOUT	78	PJ.06

(2) KerberosSDR Specification Sheet:

KerberosSDR Hardware Specs

Each RTL-SDR on board the KerberosSDR is based on the R820T2 and RTL2832U chips, which are the same chips used in the most common RTL-SDR dongles.

- **Frequency Range:** 24 MHz – 1.7 GHz
- **ADC Sample Rate:** 2.4 MSPS
- **Bit Depth:** 8 Bits

KerberosSDR connects its RTL-SDRs to the calibration board via four u.FL cables. The calibration board then has four u.FL -> SMA cables that can be used to connect to antennas.

What's Included?

If you back our campaign you'll receive one KerberosSDR set. This includes:

- The KerberosSDR Board which has:
 - 4x RTL-SDR R820T2 Receivers
 - A wideband noise source that can be switched in software
 - USB Hub so only one USB connection is required
- A calibration board for synchronizing samples with the noise source
- A shielded metal enclosure
- Cables for connecting the two boards and noise source

What you'll need to provide: You'll need to provide your own antennas for your application (e.g. four magnetic whips for direction finding, two directional antennas for passive radar), a 5V USB power supply, and a microUSB USB cable, and a Linux computing device like a PC/laptop or single board computer like a Raspberry Pi 3, Tinkerboard or Odroid XU4. (Must run Linux natively – VMs have too much USB lag for coherency).



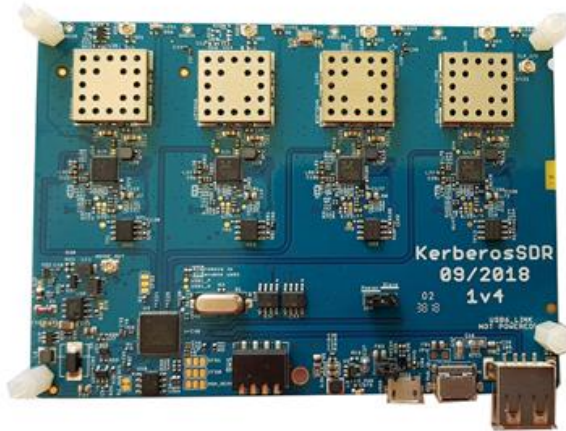

Please Note: Images are of prototype hardware – subject to change slightly. The actual product will come in a metal enclosure with SMA antenna connectors.

Power Requirements

The KerberosSDR takes a USB power input. Any 3A supply should be sufficient. On some modern PCs you may even be able to directly power the board without any additional power supply.

Applications

Some applications might include:

- Using passive radar to monitoring aircraft that do not transmit ADS-B
- Monitoring vehicle or marine traffic with passive radar
- Pinpointing the source of VHF/UHF noise, pirates, interference, jammers, unknown signals etc using direction finding
- Direction finding for amateur radio fox hunts
- Determining the location of rescue or stolen asset beacons
- Combining multiple small dishes to create a large dish for radio astronomy via beam forming.
- Using the four tuners as standard RTL-SDRs. e.g. two for trunking, one for ADS-B and one for weather satellites.

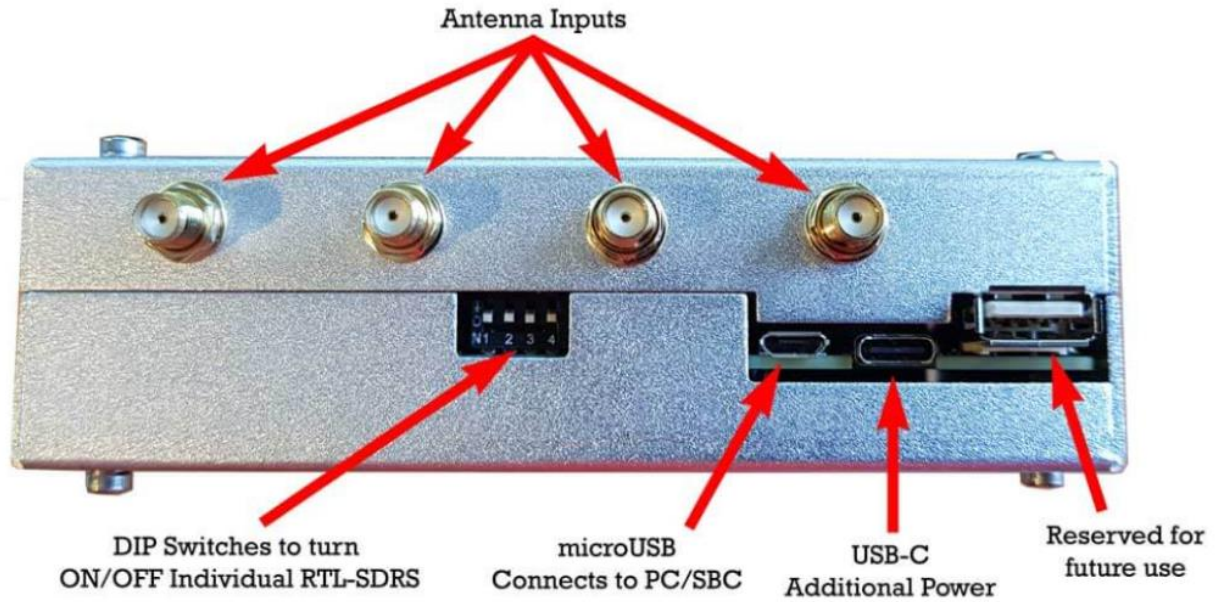

KerberosSDR Labelled Ports

Antenna 1 is the port to the left. You can confirm this by looking at the DIP switches. The writing on the DIP switches indicates the antenna order.

40 Pin Header

Please note that this header is experimental only and we are not supporting use of this feature at the moment.

It is designed for powering a Raspberry Pi. If you connect a Raspberry Pi to the header, and power the KerberosSDR you can power it this way. But you must have a very good power supply for the KerberosSDR.

(3) Maswell Whip Antenna Specification Sheet:



4G/3G/LTE antenna 900/1800/2100 MHz Circular Base mini

AN_GSM_016L



Mechanical dimension

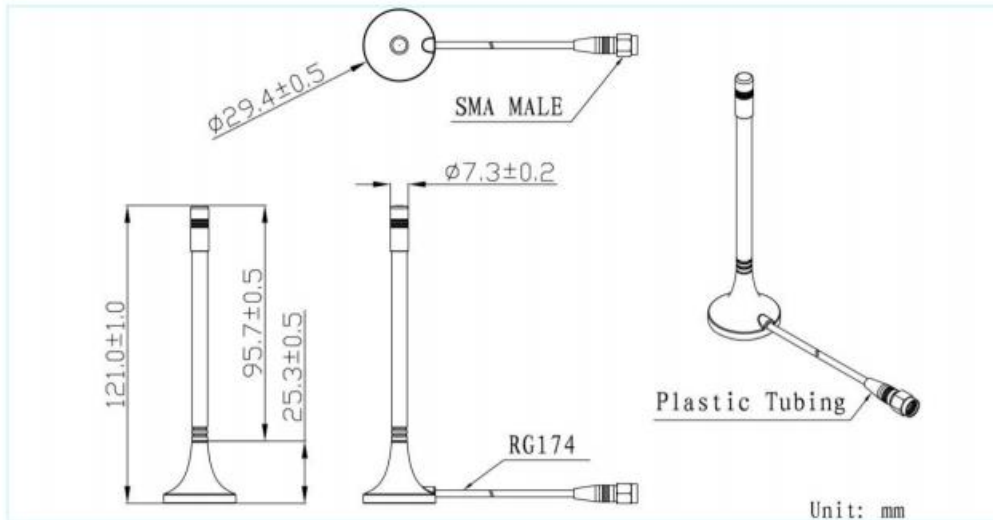

Specifications

Item	Specifications	
Antenna	Frequency Range	824~960/1710~2170MHz
	Polarization	Linear
	Gain	2.0dBi (Zenith)
	V.S.W.R	<2.0
	Impedance	50Ω
Mechanical	Cable	4 meters
	Connector	SMA
	Mounting Method	Magnet
Environmental	Operating Temperature	-40℃~+85℃
	Vibration	10 to 55Hz with 1.5mm amplitude 2hours
	Environmentally Friendly	ROHS Compliant

Radiation Patterns

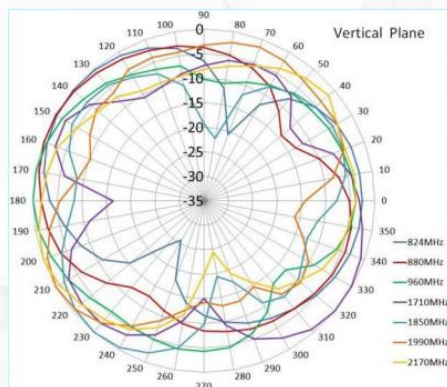
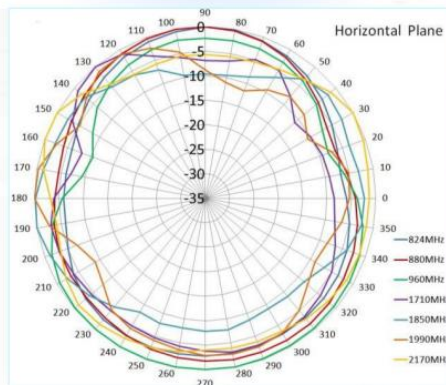

(4) IMX219-83 Stereo Camera Specification Sheet:

IMX219-83 Stereo Camera

From Waveshare Wiki

Introduction

IMX219 Camera, 800 megapixels, and 83 FOV. Compatible with Jetson nano Developer Kit (B01)

More (<https://www.waveshare.com/imx219-83-Stereo-camera.htm>)

Specification

- 8 Megapixels
- Sensor: Sony IMX219
- Resolution: 3280 × 2464 (per camera)
- Lens specifications:
 - CMOS size: 1/4inch
 - Focal Length: 2.6mm
 - Angle of View: 83/73/50 degree (diagonal/horizontal/vertical)
 - Distortion: <1%
 - Baseline Length: 60mm
- ICM20948:
 - Accelerometer:
 - Resolution: 16-bit
 - Measuring Range (configurable): ±2, ±4, ±8, ±16g
 - Operating Current: 68.9uA
 - Gyroscope:
 - Resolution: 16-bit
 - Measuring Range (configurable): ±250, ±500, ±1000, ±2000°/sec
 - Operating Current: 1.23mA
 - Magnetometer:
 - Resolution: 16-bit
 - Measuring Range: ±4900μT
 - Operating Current: 90uA
- Dimension: 24mm × 85mm

IMX219-83 Ste



IMX219 sensor, FOV 83, compatible with jetson nano

Primary Attribute
Category: Modules, Cameras

Brand: Waveshare

Website
International: Website
(<https://www.waveshare.com/imx219-83-stereo-camera.htm>)

Chinese: 网站
(<http://www.waveshare.net/shop/IMX219-83-Stereo-Camera.htm>)

Onboard Interfaces
CSI

Related Products

- IMX219-77 Camera
- IMX219-77IR Camera
- **IMX219-83 Stereo Camera**
- IMX219-120 Camera
- IMX219-160 Camera
- IMX219-160IR Camera
- IMX219-160 IR-CUT Camera
- IMX219-170 Camera
- IMX219-200 Camera
- RPi NoIR Camera V2
- RPi Camera V2

(5) iFlight Micro BEC 5V 3A (Battery Eliminating Circuit) Specification Sheet:



- VBAT: 5-36V
- OUT: 5V 3A/12V 2A

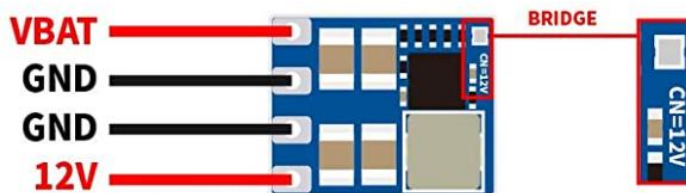
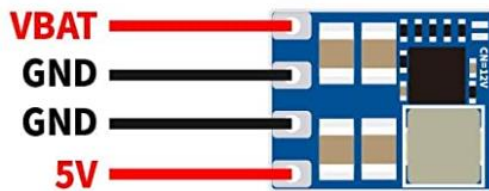
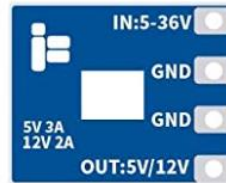

The iFlight Mirco BEC features step-down switch mode, high-efficiency synchronous rectification, and the ability to step down from an input voltage of up to 36V to a low output stable voltage, which makes it ideal for step-down voltage applications.

It offers a very compact solution to achieve 2A/3A output current over a wide input supply voltage (5 to 36V).

* Short connect ON-12V, the output voltage is 12V 2A. When disconnected, the output voltage is 5V 3A.

Features:

- Step-down switch mode
- High-efficiency synchronous
- Wide 5V to 36V Input voltage range
- The voltage output can be 5V or 12V adjustable. (default 5V)

Specs:

- Input voltage: 2-6S(5-36V)
- BEC Output: 5V/3A, 12V/2A (default 5V/3A)
- Size: 14*11*1mm
- Pins distance: 2.54mm
- Weight: 0.8g

Package Included:

- 3pcs* iFlight Mirco 2-6S BEC - 5V/12V Output
- 3set * Connecting cables

(6) Yuenhoang 12V Underwater Thruster Specification Sheet:

Yuenhoang 12V Underwater Thruster Brushless Motor Drive Engine 80mm Propeller 3-5kg Thrust 3S Lipo Parts for RC Bait Tug Boat ROV Submarine

- The motor can be turned forward and reversed.
- The motor coil resin package is waterproof. After one month of soaking water test, it can be used normally again.
- Can be used for tug boats, fishing bait boats, underwater robots, etc.
- It has been tested that a single underwater propeller can propel a person's kayaking slowly.



Specification:

- Voltage: 12v
- KV value: 460KV
- Speed: 5300 rpm
- Diameter: 90mm
- Height: 93mm
- Three-leaf prop diameter 80mm
- Mounting screw: 3mm
- Installation size: 36x20mm
- Red line length 350mm diameter 7mm (high temperature resistant soft silicone line)
- Connecting bullets 3.5mm
- Power supply: 3S lithium battery or 12V battery
- Suitable ESC: 40A brushless ESC
- Driving force: 3-5kg

(7) Myswift ESC 40A (Speed Controller) Specification Sheet:



Style:XT60 connector

- ★ Pre-soldered with XT60 Connector and 3.5mm bullet plugs for easy connection.
- ★ Safety Arming Feature: Regardless the throttle stick position, the motor will not spin after battery connected.
- ★ Throttle Calibration: Throttle range can be configured to provide best throttle linearity, fully compatible with all market available transmitters.
- ★ Selectable program setting.
- ★ Full Protection.
- ★ 100% brand new.

Features:

Low voltage cutoff protection / Over-heat protection / Throttle signal lost protection.

Specification:

1. Continuous current: 40A.
2. Burst Current (>10s): 55A
3. BEC output: 5V 3A.
4. BEC mode: Linear
5. BEC Output Capability: 5 Servos (2S Lipo) / 4 Servos (3S Lipo)
6. Battery Cell: 2-3S (Lipo) / 5-9 cells (NiMH)
7. Maximum speed: 210000 RPM (2 poles motor), 70000 RPM (6 poles motor), 35000 RPM (12 poles motor).
8. Usage: Apply for 400/450 helicopter 3D, and 32 level fixed wing sports
9. Weight: 39g
10. Dimension: 68mm x 25mm x 8mm

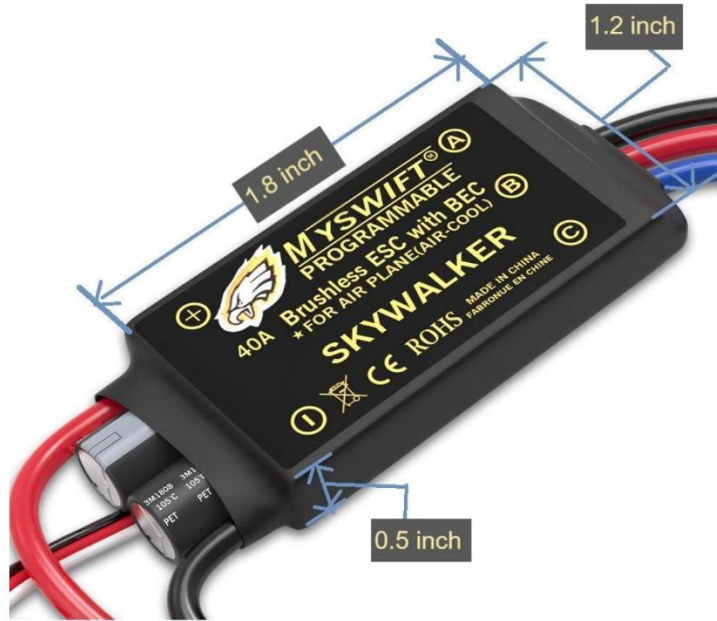

Support Battery cell: 2-3s (Lipo) / 5-9 cells (NiMH)

User Manual of Brushless Speed Controller

es0909-20130709

Thanks for purchasing our Electronic Speed Controller (ESC). High power system for RC model is very dangerous, please read this manual carefully. In that we have no control over the correct use, installation, application, or maintenance of our products, no liability shall be assumed nor accepted for any damages, losses or costs resulting from the use of the product. Any claims arising from the operating, failure or malfunctioning etc. will be denied. We assume no liability for personal injury, property damage or consequential damages resulting from our product or our workmanship. As far as is legally permitted, the obligation to compensation is limited to the invoice amount of the affected product.

Specifications (Note: The Skywalker-6A, 12A, 12AE, 20A, 50A, 60A and 80A are only used for RTF applications)

Model	Cont. Current (mA)	BEC Mode	BEC Output	BEC Output Capability			Battery Cell	Weight	Size
				2S Lipo	3S Lipo	4S Lipo			
es0909-6A	6A	BA	Linear 5V/0.8A	3 servos	2 servos	2	2S 5-6 cells 5.5g	32*12*4.5	
es0909-12A	12A	15A	Linear 5V/1A	3 servos	2 servos	2	2-3S 5-9 cells 9g	38*19*6	
es0909-12AE	12A	15A	Linear 5V/2A	5 servos	4 servos	2	2-3S 5-9 cells 10g	38*18*7	
es0909-20A	20A	25A	Linear 5V/2A	5 servos	4 servos	2	2-3S 5-9 cells 13g	42*25*8	
es0909-30A	30A	40A	Linear 5V/2A	5 servos	4 servos	2	2-3S 5-9 cells 17g	48*25*8	
es0909-40A	40A	55A	Linear 5V/3A	5 servos	4 servos	2	2-3S 5-9 cells 20g	48*25*8	
es0909-40A-LIBEC	40A	55A	Switch 5V/3A	5 servos	5 servos	2	2-4S 5-12 cells 43g	65*29*12	
es0909-50A-LIBEC	50A	65A	Switch 5V/3A	5 servos	5 servos	2	2-4S 5-12 cells 43g	65*29*12	
es0909-60A-LIBEC	60A	80A	Switch 5V/3A	5 servos	5 servos	2	2-4S 5-18 cells 63g	77*35*14	
es0909-60A-OPTOC	60A	80A	N/A	8 servos	8 servos	2	2-4S 5-18 cells 60g	66*38*12	
es0909-80A-LIBEC	80A	100A	Switch 5V/3A	8 servos	8 servos	2	2-4S 5-18 cells 82g	66*38*12	
es0909-80A-OPTOC	80A	100A	N/A	8 servos	8 servos	2	2-4S 5-18 cells 79g	66*38*12	

Programmable Items (The option written in bold font is the default setting)

- Brake Setting: Enabled / Disabled
- Battery Type: Lipo / NiMH
- Low Voltage Protection Mode(Cut-Off Mode): **Soft Cut-Off** (Gradually reduce the output power) / Cut-Off (Immediately stop the output power)
- Low Voltage Protection Threshold(Cut-Off Threshold): Low / Medium / High
 - For lithium battery, the battery cell number is calculated automatically. Low / medium / high cutoff voltage for each cell is: 3.15V/3-0.45V
 - For NiMH battery, low / medium / high cutoff voltages are 0%/50%/85% of the startup voltage (i.e. the initial voltage of battery pack), and 0% means the low voltage cut-off function is disabled. For example: For a 6 cells NiMH battery, fully charged voltage is 1.44V*6=8.64V, when "Medium" cut-off threshold is set, the cut-off voltage will be: 8.64*50%=4.32V.
- Startup Mode: Normal / Soft / Super-Soft (300ms / 1.5s / 3s)
 - Normal mode is suitable for fixed-wing aircraft. Soft or Super-soft modes are suitable for helicopters. The initial acceleration of the Soft and Super-Soft modes are slower, it takes 1.5 second for Soft startup or 3 seconds for Super-Soft startup from initial throttle advance to full throttle. If the throttle is completely closed (throttle stick moved to bottom position) and opened again (throttle stick moved to top position) within 3 seconds after the first startup, the re-startup will be temporarily changed to normal mode to get rid of the chance of a crash caused by slow throttle response. This special design is suitable for aerobatic flight when quick throttle response is needed.
- Timing: Low / Medium / High (3.75' / 15' / 26.25')
 - Usually, low timing is suitable for most motors. To get higher speed, High timing value can be chosen.

Begin To Use Your New ESC

IMPORTANT! Because different transmitter has different throttle range, please calibrate throttle range before flying. Throttle range setting (Throttle range should be reset whenever a new transmitter is being used)

Switch on the transmitter, move throttle stick to the top position	Connect battery pack to the ESC, and wait for about 2 seconds	The "Beep-Beep" tone should be emitted, means the top point of throttle range has been confirmed	Move throttle stick to the bottom position, several "beep" tones should be emitted to present the amount of battery cells	A long "Beep" tone should be emitted, means the lowest point of throttle range has been correctly confirmed
--	---	--	---	---

Normal startup procedure

Move throttle stick to bottom position and then switch on transmitter.	Connect battery pack to ESC, special tone like " 2 123 " means power supply is OK	Several "beep-" tones should be emitted to present the amount of lithium battery cells	When self-test is finished, a long "beep-" tone should be emitted	Move throttle stick upwards to go flying
--	---	--	---	--

Protection Function

- Start up failure protection: If the motor fails to start within 2 seconds of throttle application, the ESC will cut-off the output power. In this case, the throttle stick **MUST** be moved to the bottom again to restart the motor. (Such a situation happens in the following cases. The connection between ESC and motor is not reliable, the propeller or the motor is blocked, the gearbox is damaged, etc.)
- Over-heat protection: When the temperature of the ESC is over about 110 Celsius degrees, the ESC will reduce the output power.
- Throttle signal loss protection: The ESC will reduce the output power if throttle signal is lost for 1 second, further loss for 2 seconds will cause the output to be cut-off completely.

Trouble Shooting

Trouble	Possible Reason	Action
After power on, motor does not work, no sound is emitted	The connection between battery pack and ESC is not correct	Check the power connection. Replace the connector.
After power on, motor does not work, such an alert tone is emitted: "beep-beep-, beep-beep-beep-beep-" (Every "beep-beep-" has a time interval of about 1 second)	Input voltage is abnormal, too high or too low.	Check the voltage of battery pack.
After power on, motor does not work, such an alert tone is emitted: "beep-, beep-, beep-, beep-" (Every "beep-" has a time interval of about 2 seconds)	Throttle signal is irregular	Check the receiver and transmitter. Check the cable of throttle channel.
After power on, motor does not work, such an alert tone is emitted: "beep-, beep-, beep-" (Every "beep-" has a time interval of about 0.25 second)	The throttle stick is not in the bottom (lowest) position	Move the throttle stick to bottom position
After power on, motor does not work, a special tone " 2 123 " is emitted after 2 seconds	Direction of the throttle channel is reversed, so the ESC has entered the program mode	Set the direction of throttle channel correctly
The motor runs in the opposite direction	The connection between ESC and the motor need to be changed.	Swap any two wire connections between ESC and motor

Program the ESC with your transmitter (4 Steps)

- Please make sure the throttle curve is set to 0 when the throttle stick is at bottom position and 100% for the top position.
- Enter program mode
- Select programmable items
- Set item's value (Programmable value)
- Exit program mode

- Enter program mode
 - Switch on transmitter, move throttle stick to top position, connect the battery pack to ESC
 - Wait for 2 seconds, the motor should emit special tone like "beep-beep-"
 - Wait for another 5 seconds, special tone like " 2 123 " should be emitted, which means program mode is entered

2. Select programmable items

- After entering program mode, you will hear 8 tones in a loop with the following sequence: If you move the throttle stick to bottom within 3 seconds after one kind of tones, this item will be selected.
- "beep" brake (1 short tone)
 - "beep-beep-" battery type (2 short tone)
 - "beep-beep-beep-" cutoff mode (3 short tone)
 - "beep-beep-beep-beep-" cutoff threshold (4 short tone)
 - "beep-" timing (1 long 1 short)
 - "beep-beep-" set all to default (1 long 2 short)
 - "beep-beep-" exit (2 long tone)
 - "beep-beep-" exit (2 long tone)
- Note: 1 long "beep-" = 5 short "beep-".

3. Set item value (Programmable value)

You will hear several tones in loop. Set the value matching to a tone by moving throttle stick to top when you hear the tone, then a special tone " 2 123 " emits, means the value is set and saved. (Keeping the throttle stick at top, you will go back to Step 2 and you can select other items, or moving the stick to bottom within 2 seconds will exit program mode directly)

Items	Tones	"beep-" 1 short tone	"beep-beep-" 2 short tones	"beep-beep-beep-" 3 short tones
Brake	Off	On		
Battery type	Lipo	NiMH		
Cutoff mode	Soft Cut	Cut-Off		
Cutoff threshold	Low	Medium	High	
Startup mode	Normal	Soft	Super Soft	
Timing	Low	Medium	High	

4. Exit program mode

- There are 2 ways to exit program mode:
- In step 3, after special tone " 2 123 ", please move throttle stick to the bottom position within 2 seconds.
 - In step 2, after tone "beep-beep-" (th at it. The item #8), move throttle stick to bottom within 3 seconds.

Appendix E: Fully Annotated Code

The fully annotated code for this project can be found in the “CAD & Software Files” submission page on Canvas.

Appendix G: Failure Modes and Effects Analysis (FMEA)

FMEA Table:

System / Function	Potential Failure Mode	Potential Effects of the Failure Mode	Severity	Potential Causes of the Failure Mode	Current Preventative Activities	Occurrence	Current Detection Activities	Detection Priority	Recommended Action(s)	Responsibility & Target Completion Date	Action Results			
											Actions Taken	Severity	Occurrence	Criticality
Provide thrust to SAVER	Doesn't supply enough thrust	Slowed/incorrect Movement	5	-Propellers break -Debris in thruster -Propeller lock up/rust	-Select for worst case impact -Cage propellers -Run the device	5	-Visual inspection for cracks/damage and entanglement -Schedule regular propeller runs	4 100	Select a propeller, complete analysis on the likelihood of breaking	Josh, May 8th				
	Thruster electronics failure	Unable to move/steer	9	-Wiring pulled out -Short cause by water leak -Overpowered motor controller -Solder failure from impact force or vibration	-Solder effectively -Make waterproof enclosure -Impact dampening	3	-Visual inspection of seals, solder and wiring on thruster before use date	8 216	Research waterproofing on submersibles to improve design. Implement leak detector.	Josh, May 8th (tentative)				
Locate Astronaut	Microcontroller failure	Unable to move/steer/location finding	10	-Damaged board from impact/water leach/touching/vibrations -Overheating caused by overpowering or cooling failure -Broken solder -Stripped wiring	-Impact dampening -Determine need for cooling system -Solder effectively	1	-Visual inspection of microcontroller system before use date -In depth inspection of wires, solders, and seals before use date	6 60	Perform most testing NOT in water, be exceptionally vigilant about sealing when testing in water/drop testing	Josh, May 8th (tentative)				
	Antenna failure	Defective locating	7	-Broken from impact/debris -Bent from impact/debris -Covered antenna -Unable to capture signal due to interference	-Design for worst case impact -Stress analysis -Design to be low profile -Design to not be affected by interference	6	-Visual inspection of antenna system before use date -Tightening antennas to proper torque before use -Radio beacon tracking test before use date	2 84	Perform most testing NOT in water, be exceptionally vigilant about sealing when testing in water/drop testing	Ethan, May 8th (tentative)				
	Camera Failure	Defective locating at short range	6	Impact, water damage, water sprayed on lenses	Shield electronics for impact, have screen in front of camera	4	visual inspection	6 144	Perform most testing NOT in water, be exceptionally vigilant about sealing when testing in water/drop testing	Josh, May 8th (tentative)				
	IMU/GPS Failure	Difficulty detection SAVER's absolute location	3	impact, antenna damage, unable to locate GPS signal, water damage	Waterproof component	2	visual inspection	6 36	Perform most testing NOT in water, be exceptionally vigilant about sealing when testing in water/drop testing	Josephine, May 8th (tentative)				

FMEA Trees:

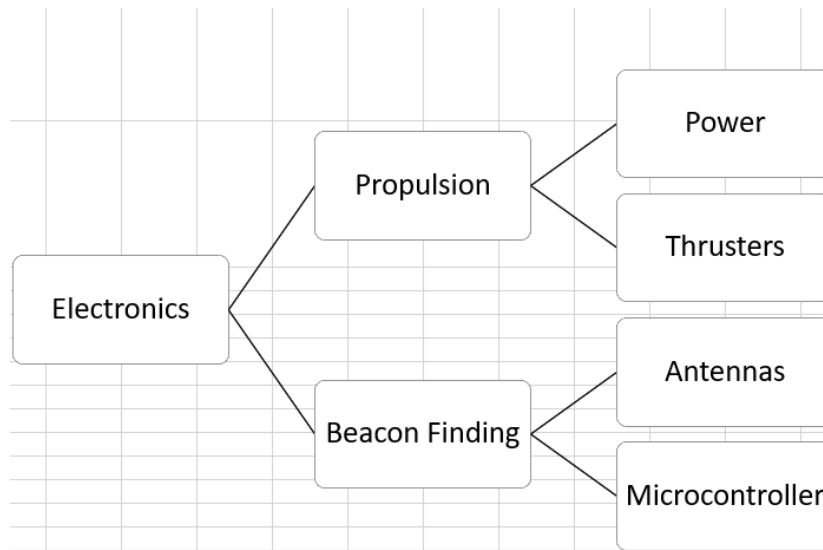

Appendix H: Design Hazard Checklist

Y	N	
Y		1. Will any part of the design create hazardous revolving, reciprocating, running, shearing, punching, pressing, squeezing, drawing, cutting, rolling, mixing or similar action, including pinch points and sheer points?
	N	2. Can any part of the design undergo high accelerations/decelerations?
	N	3. Will the system have any large moving masses or large forces?
	N	4. Will the system produce a projectile?
	N	5. Would it be possible for the system to fall under gravity creating injury?
	N	6. Will a user be exposed to overhanging weights as part of the design?
Y		7. Will the system have any sharp edges?
Y		8. Will any part of the electrical systems not be grounded?
	N	9. Will there be any large batteries or electrical voltage in the system above 40 V?
Y		10. Will there be any stored energy in the system such as batteries, flywheels, hanging weights or pressurized fluids?
	N	11. Will there be any explosive or flammable liquids, gases, or dust fuel as part of the system?
	N	12. Will the user of the design be required to exert any abnormal effort or physical posture during the use of the design?
	N	13. Will there be any materials known to be hazardous to humans involved in either the design or the manufacturing of the design?
	N	14. Can the system generate high levels of noise?
	N	15. Will the device/system be exposed to extreme environmental conditions such as fog, humidity, cold, high temperatures, etc?
Y		16. Is it possible for the system to be used in an unsafe manner?
	N	17. Will there be any other potential hazards not listed above? If yes, please explain on reverse.

Description of Hazard	Planned Corrective Action	Planned Date	Actual Date
The propellers on the side of the craft could propose a risk is foreign objects or body parts <u>come in contact with them</u>	<u>In order to ensure safety during testing,</u> thrusters were procured which contain protective coverings around the blades	April 2021	May 2021
The system could have sharp edges while being manufactured as pieces are being assembled	Precautions will be taken to dull any sharp edges before any further assembly takes place and that no sharp edges remain on the final design	April 2021	May 2021
Since the electrical system is fully contained, it will not be grounded	The electronics will be kept isolated in the design during use, and any testing of the electronics will be done with the system grounded	May 2021	Next years' SAVER
The system will contain batteries during <u>testing</u>	Precautions will be used to ensure the batteries remain isolated from water and proper battery storage and usage guidelines are followed	May 2021	Next years' SAVER
The system can be deployed improperly or at an incorrect time	Prior to testing, the area underneath the craft will be cleared. Additionally, a full water seal test will be performed before each use to reduce the risk of electric damage	May 2021	Next years' SAVER

Appendix I: Risk Assessment

Application: SAVER Mechatronics Analyst Name(s):
 Description: Design verification for SAVER's mechatronics systems Company:
 Product Identifier: Facility Location:
 Assessment Type: Detailed
 Limits:
 Sources:
 Risk Scoring System: ANSI B11.0 (TR3) Two Factor

Guide sentence: When doing [task], the [user] could be injured by the [hazard] due to the [failure mode].

Item Id	User / Task	Hazard / Failure Mode	Initial Assessment		Risk Reduction Methods /Control System	Final Assessment		Status / Responsible /Comments /Reference
			Severity Probability	Risk Level		Severity Probability	Risk Level	
1-1-1	electrician / controls technician repair / replace wiring / systems	mechanical : pinch point Bow box / hull waterproof seals and fasteners (getting into electronic compartments)	Minor Unlikely	Negligible		Minor Unlikely	Negligible	
1-1-2	electrician / controls technician repair / replace wiring / systems	mechanical / electronic : energized equipment / live parts Battery is improperly disconnects or not disconnected	Serious Unlikely	Medium	Rubber gloves should be work to disconnect battery. Make battery disconnects bright and visable when opening electronics box, warning signals that tell electrician to disconnect battery before working on anything else.	Moderate Unlikely	Low	On-going [Daily] Ethan
1-1-3	electrician / controls technician repair / replace wiring / systems	electrical / electronic : lack of grounding (earthing or neutral) Impossible to ground vehicle due to it being small, plastics, and operating in medium that it can't be grounded to.	Serious Remote	Low		Serious Remote	Low	
1-1-4	electrician / controls technician repair / replace wiring / systems	electrical / electronic : shorts / arcing / sparking High current/voltage output to thrusters could produce shocks	Serious Unlikely	Medium	Heavily insulated wires to thrusters. rubber gloves when working on these components	Moderate Unlikely	Low	On-going [Daily] Josh
1-1-5	electrician / controls technician repair / replace wiring / systems	electrical / electronic : improper wiring If rewired improperly or wires damaged by some events, could cause shorts	Moderate Likely	Medium	Verify wiring is done correctly for every use by comparing to wiring diagram that will be provided	Moderate Unlikely	Low	Action Item Josephine
1-1-6	electrician / controls technician repair / replace wiring / systems	electrical / electronic : water / wet locations Breaking of seals or leakage when opening electronics boxes.	Moderate Unlikely	Low		Moderate Unlikely	Low	On-going [Daily]
1-1-7	electrician / controls technician repair / replace wiring / systems	slips / trips / falls : slip Operation or maintenance around water source	Minor Unlikely	Negligible		Minor Unlikely	Negligible	
1-1-8	electrician / controls technician repair / replace wiring / systems	ergonomics / human factors : posture Bending over hull to get to electronics	Minor Unlikely	Negligible		Minor Unlikely	Negligible	
1-2-1	electrician / controls technician adjust controls (code)	electrical / electronic : shorts / arcing / sparking Inproper coding could cause overloading of curcuits	Minor Likely	Low	Add fail safe in code that will check level of current and return errors if circuit will be overloaded.	Minor Unlikely	Negligible	In-process Ethan /Coding still in process
1-2-2	electrician / controls technician adjust controls (code)	ergonomics / human factors : posture Sitting at computer	Minor Likely	Low	Manditory breaks every hour.	Minor Unlikely	Negligible	On-going [Daily] Tyler
1-2-3	electrician / controls technician adjust controls (code)	ergonomics / human factors : eye fatigue Long computer sessions	Minor Likely	Low		Minor Unlikely	Negligible	
2-1-1	operator (deployer) deployment	mechanical : unexpected start Unwanted thruster start due to accidently activation of device	Moderate Unlikely	Low	Thrusters will be shielded, mesh sheets could be positioned over open ends of thruster	Moderate Remote	Negligible	Complete [4/28/2021] Josh /Thrusters have shields

Item Id	User / Task	Hazard / Failure Mode	Initial Assessment		Risk Reduction Methods /Control System	Final Assessment		Status / Responsible /Comments /Reference
			Severity Probability	Risk Level		Severity Probability	Risk Level	
2-1-2	operator (deployer) deployment	electrical / electronic : energized equipment / live parts Electronics contained in hull / bow box	Moderate Unlikely	Low	Insulated wiring. Check seals before deployment	Moderate Unlikely	Low	Complete [4/28/2021] Ethan /Wiring has insulation
2-1-3	operator (deployer) deployment	electrical / electronic : shorts / arcing / sparking Leaking/damage could cause power system to short	Moderate Unlikely	Low	Check seals before deployment	Moderate Unlikely	Low	Action Item Josephine
2-1-4	operator (deployer) deployment	slips / trips / falls : fall hazard from elevated work Dropping boat from 10ft height	Moderate Unlikely	Low	Verify drop location is clear, yell multiple warnings before drop, safe testing protocols	Moderate Remote	Negligible	TBD Tyler /SAVER 1, not SAVER 2
2-1-5	operator (deployer) deployment	ergonomics / human factors : lifting / bending / twisting Oddly shaped hull, could prove difficult to grip	Minor Unlikely	Negligible		Minor Unlikely	Negligible	
2-2-1	operator (deployer) retrieval	mechanical : pinch point Getting boat out of water could pinch between boat and dock	Minor Unlikely	Negligible		Minor Unlikely	Negligible	
2-2-2	operator (deployer) retrieval	electrical / electronic : shorts / arcing / sparking If electrical system was compromised during operation	Moderate Unlikely	Low	Gloves worn when retrieving device	Minor Unlikely	Negligible	On-going [Daily] Ethan
2-2-3	operator (deployer) retrieval	slips / trips / falls : slip Operating near water, could be slippery when wet	Minor Unlikely	Negligible		Minor Unlikely	Negligible	
2-2-4	operator (deployer) retrieval	ergonomics / human factors : lifting / bending / twisting Pulling up from water could be done improperly	Moderate Unlikely	Low		Moderate Unlikely	Low	
3-1-1	operator (astronaut) normal operation	mechanical : drawing-in / trapping / entanglement Caught in thrusters	Moderate Unlikely	Low	Thrusters will be shielded	Moderate Remote	Negligible	

Item Id	User / Task	Hazard / Failure Mode	Initial Assessment		Risk Reduction Methods /Control System	Final Assessment		Status / Responsible /Comments /Reference
			Severity Probability	Risk Level		Severity Probability	Risk Level	
3-1-2	operator (astronaut) normal operation	mechanical : impact High speed impact when approaching astronaut caused by failure to detect astronaut	Moderate Unlikely	Low	If detection is not happening, device will operate at lower speeds to reduce impact force	Moderate Unlikely	Low	TBD Josh /Done in coding for speed calculations
3-1-3	operator (astronaut) normal operation	electrical / electronic : shorts / arcing / sparking If damaged during travel, astronaut could be shocked	Minor Unlikely	Negligible		Minor Unlikely	Negligible	
3-2-1	operator (astronaut) misuse - flipping	mechanical : drawing-in / trapping / entanglement Flipping could cause thrusters to be out of the water, proving more dangerous to astronaut trying to reach for supplies.	Moderate Likely	Medium	Thrusters are shielded. Adding gyroscope sensor to cut power to thrusters if a flip has been detected.	Moderate Remote	Negligible	In-process Josephine /IMU/GPS has been ordered

Appendix J: User Manual

Introduction

This user's manual will serve to lay out the procedures necessary to set up and operate the SAVER device electronic components. Please read all safety information prior to use.

Operation

To operate the SAVER device, it must first be powered on, and the operator must ensure all components are receiving power. The critical components of the system are shown below. The first critical components are the stereo cameras, shown above in Figure 1. The NVIDIA Jetson that is attached to the stereo cameras needs to be fed 5V 3A through a MicroUSB wire. This can be done using a 5V power supply capable of outputting greater than or equal to 3A.



Figure 1: Jetson and Cameras

These cameras must be operational before deployment. This should be verified by connecting SAVER to a computer and verifying that the camera system is fully operational and reading data. This code and image output should look similar to what is shown below in Figure 2.

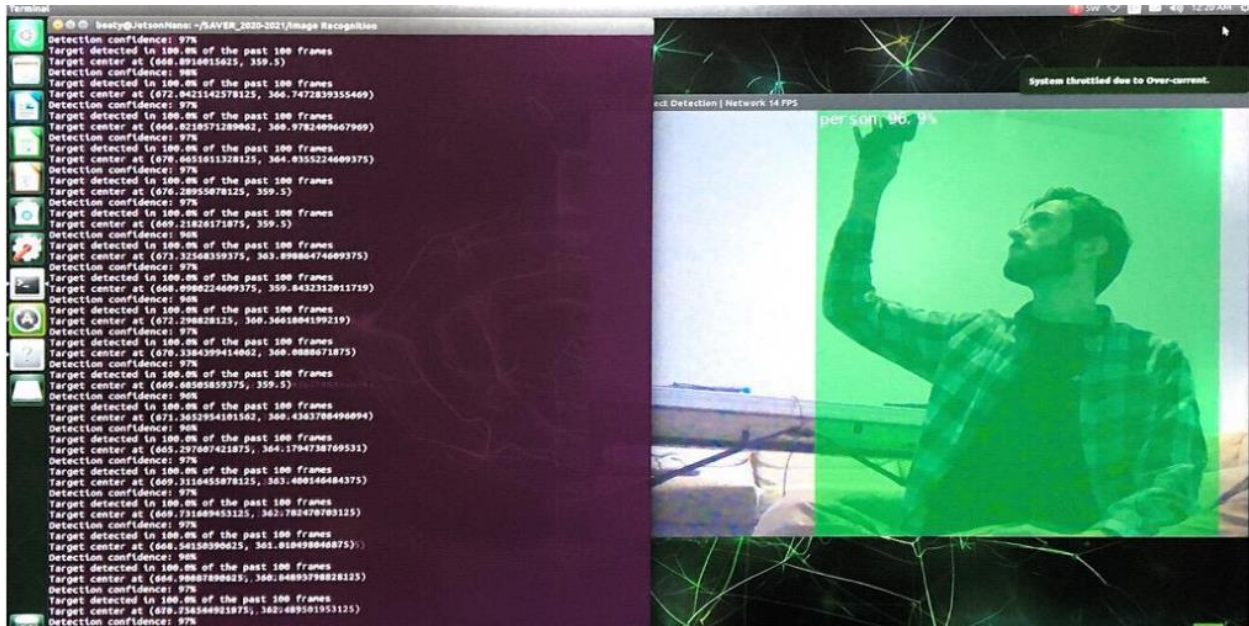

Figure 3: Code Output Verification

Below in Figure 3 is the Kerberos system with all 4 antennas. The Kerberos has two MicroUSB ports: one for power and one for data. Figure 4 shows the configuration of the inputs on the device, and Figure 5 shows the configuration of the antennas and their spacing. Make sure that all antennae and cables are secure in the Kerberos before plugging in. To download the software for the Kerberos and begin its initialization, follow the direction from this URL: <https://github.com/rfjohnso/kerberosdr/>.



Figure 3: Kerberos system

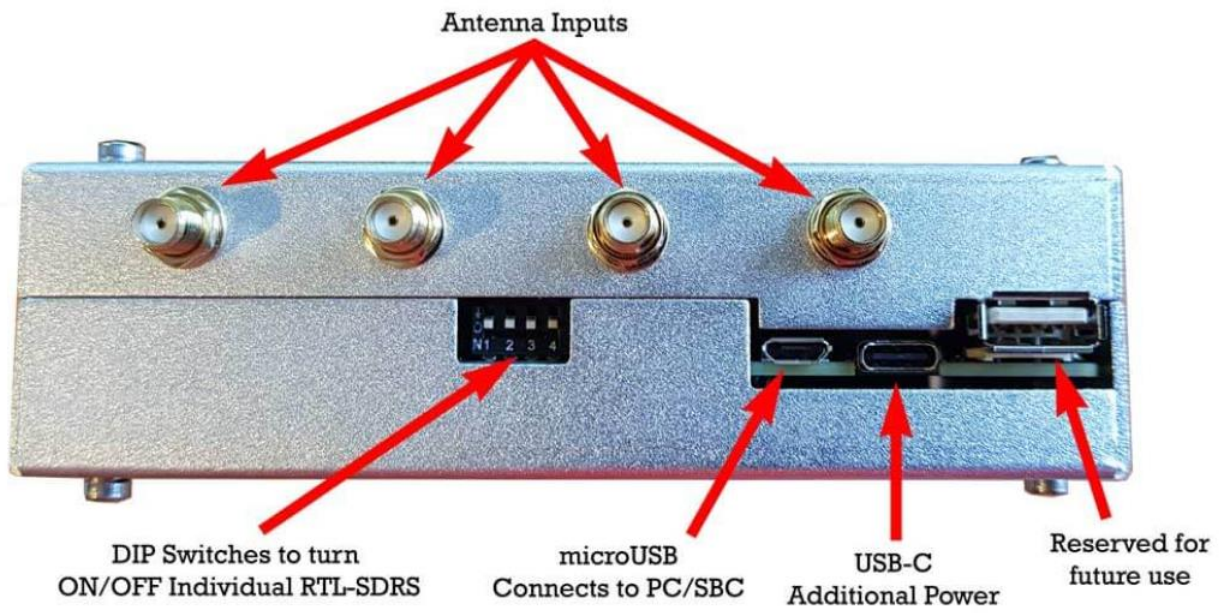
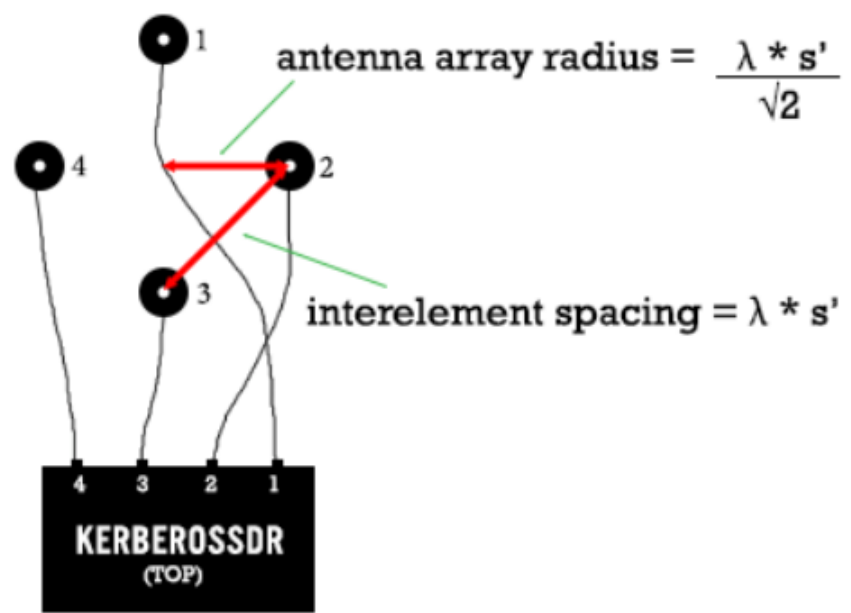

Figure 4: Diagram of KerberosSDR ports. Antennas should be connected 1-4 from left to right. They also correspond to the DIP switches.



λ = frequency wavelength
 s' = interelement spacing factor (0.1 - 0.5) (~0.33 recommended)
 s = radius adjusted spacing factor = $s' / \sqrt{2}$

Figure 5: Spacing diagram for the Kerberos antenna array.

Once these critical components have been verified, the SAVER craft can be tested along with the tester beacon emitting 915 MHz. This craft does not have a set user, as we will be conducting all testing and operating of the device, rather than the true use case of oceanic deployment.

Assembly/Repair

The user should have to do little to no assembly work in order for SAVER to be operational. Since the user is an astronaut, and since the SAVER device will locate them automatically, the user should not need to do any set up in order for the device to be operated. Whoever is deploying the device, likely NASA will need to make sure that the device is fully functional prior to deployment.

For the purposes of this team, the operator will be the team itself, verifying that the craft is operational. For future operational cases in which the device is not to be operated or directly overseen by a team member, the SAVER device will already be fully assembled, and the non-team operator will have to do no assembly.

If the craft becomes non-operational or is suspected to be unsafe to use, then it should be immediately removed from water (if applicable), powered off, and returned to the team for diagnosis and repair. As of now, only the team should perform repairs on the craft.

Parts List

For any necessary repairs, a list of parts for the device can be found in Appendix Y, the manufacturing plan. Every component needed for SAVER is listed within this document, as well as where the part can be acquired.

Appendix K: Design Verification Plan

DVP&R - Design Verification Plan (& Report)											
Project:		F86 SAVER		Sponsor:		NA		Edit Date:		4/22/2021	
TEST PLAN								TEST RESULTS			
Test #	Specification	Test Description	Measurements	Acceptance Criteria	Required Facilities/Equipment	Parts Needed	Responsibility	TIMING		Numerical Results	Notes on Testing
								Start date	Finish date		
1	Kerberos Beaing Test	Place beacon in field, place SAVER at 10 different locations approaching beacon from 100 ft. away	Bearing of SAVER relative to beacon	Scale of 1-10, 10 being perfect, 0 being no detection	Field	Kerberos, 4 antennas, beacon	Ethan	4/17/2021	5/23/2021	Kerberos accuracy is still limited and difficult to numerically validate. Results have been mixed and fine tuning is required for more accurate numerical results	The team has decided to move past the testing phase, despite the lac of clear numerical data. We want to focus on creating a finished product instead of dedicating more time to fine tuning and testing.
2	Camera Distance Test	Place beacon in field, place SAVER at 10 different locations approaching beacon from 10 ft. away	Distance from SAVER to beacon	Scale of 1-10, 10 being perfect, 0 being no detection	Field	Jetson, stereo camera, beacon	Josh	4/17/2021	5/23/2021	The accuracy of the depth mapping is still limited and difficult to numerically validate. Results have been mixed and fine tuning is required for more accurate numerical results	A live disparity map is generated in which the target can be distinguished at close range. The quality of the map will be greatly improved with more rigorous camera calibration. The team has decided to leave the testing as is and focus on creating a finished product, even though this is not fully accurate
3	Camera Recognition Test	Place test subject in field, place SAVER at 10 different locations approaching beacon from 10 ft. away	Image recognition of target	Scale of 1-10, 10 being perfect, 0 being no recognition	Field	Jetson, stereo camera, image recognition test subject	Josh	4/17/2021	5/23/2021	Camera recognition was accurate up to 50 ft away with over 90% consistency	At close range with a stable image, the the target will be recognized and its center recorded in all frames. This will not be the case in longer distance.
4	GPS Test	Test the accuracy of the GPS location subsystem	Ability to recognize and update location and orientation in real time	Pass/Fail, can SAVER accurately determine position data	Field	IMU/GPS assembly	Josephine	5/1/2021	5/23/2021	GPS was accurate within 95% of real location in all tests	N/A

Appendix L: Testing Procedures

Although we did not end up testing our hardware along our previously written guidelines, the original testing procedures are attached below.

KerberoSDR Test Procedure:

Team: F86

Test Name: 360-Degree Bearing Test

Purpose: *Find the tolerance/uncertainty of the bearing output of the KerberosSDR. Test if the tolerance/uncertainty is constant over the entire 360-degree field and for different distances from the beacon.*

Description of Test: *Use known bearing angles from an emitting beacon to test KerberosSDR system's tolerance and uncertainty.*

Test Equipment Required:

- KerberoSDR
- 4x Maswell 890-915 MHz antennas
- Laptop running Linux (will act as power supply and data collection device)
 - 2X MicroUSB cable
- 3D printed antenna positioning device (See drawing on last page)
- Radio beacon emitting 900MHz.
- 2 X [6"x6"x6"] box (any non-metallic material, cardboard is a good choice)
- 50-foot nonelastic string
- 100-foot nonelastic string
- 24 X Small diameter wooden stakes
- Protractor (physical or printout attached)
- iPhone with Compass app

Hazards

- Electrical discharge (extremely minor)

PPE Requirements:

None

Facility:

Open flat field

Procedure:

Before completing this test, please see Beacon and KerberosSDR setup procedures if you do not have those set up yet. If you do have them set up, continue from here.

1. Establish origin for beacon transmitter.
 - a. Place corner of one support boxes at origin chosen.
 - b. Set up transmitter on top of box with antenna orientated upwards on origin corner.
 - c. Plug in 9V battery to Arduino power supply. Press reset button on Arduino to run main code which should start emitting 900MHz frequency.

2. Set up KerberosSDR using Linux computer.
 - a. Use double sided tape on the bottom of antennas and attach them to the 3D printed antenna holder.
 - b. Plug Kerberos using MicroUSB cord.
 - c. Plug in 4 Maswell antennas into correctly numbered ports.
 - d. Startup Kerberos Demo Software (from Kerberos website, will be predownloaded)
 - e. Press "Synchronize" button on demo software and wait till plots change and look like each other.
 - f. Press "Run" button on software which will pull up digital compass.

3. From the origin, use the 50-foot rope and the protractor to measure points every 15°. Figure 1 shows an example of how the first quadrant would look.
 - a. The best way to do this is have one person at the end of the rope and the other at the origin looking over the protractor calling out when the bearing is correct.
 - b. Place a stake at the end of the rope when it is at the correct bearing.
 - c. Repeat this for all 360-degrees on the compass. This should result in 24 points.

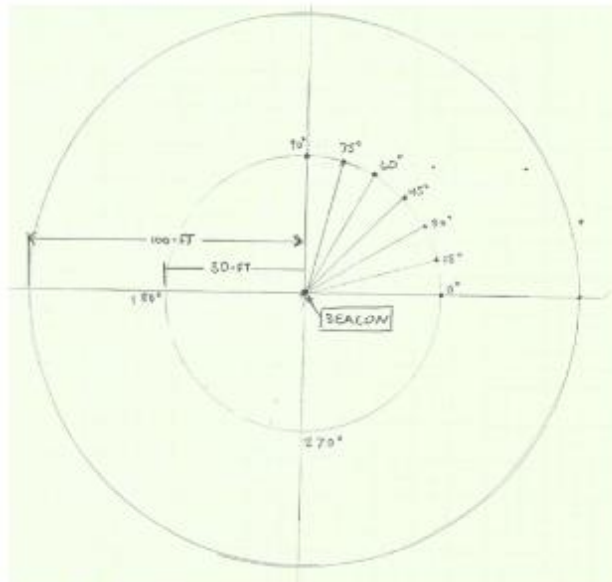

Figure 1. Schematic of first quadrant of bearing tests.

4. Take 3 different bearing measurements (A, B, and C) at each location, taken 30 seconds apart from one another. Record values in Table 1.
 - a. Slide the small hole on antenna holder onto stake in the ground. Use your phone on the side of the holder to orient the front antennas bearing north.
 - b. Repeat for all bearings and record in Table 1.

Table 1. 50-foot radius readings.

Bearing [deg]	0	15	30	45	60	75	90	105	120	135	150	165
Readings [deg]	A											
	B											
	C											
Bearing [deg]	180	195	210	225	240	255	270	285	300	315	330	345
Readings [deg]	A											
	B											
	C											

5. Repeat Steps 3 and 4 using the 100-foot string and calculate a new set of data in Table 2.

Table 2. 100-foot radius readings.

Bearing [deg]		0	15	30	45	60	75	90	105	120	135	150	165
Readings [deg]	A												
	B												
	C												
Bearing [deg]		180	195	210	225	240	255	270	285	300	315	330	345
Readings [deg]	A												
	B												
	C												

6. Turn off devices, clean up area.
 - a. Look over data before retrieving all stakes in case there were any missed locations.

Results: Pass Criteria, Fail Criteria, Number of samples to test

- Pass criteria: Average bearing tolerance (all data points) is less than or equal to $\pm 1.5^\circ$. Variability of tolerance over the 360-degrees is less than or equal to $\pm 3^\circ$. Difference in average bearing tolerance between 100-foot data and 50-foot data is less than or equal to $\pm 1^\circ$.
- Fail criteria: Bearing tolerances do not meet the values above.
- 24 sample point at two different distances, each with 3 data points, resulting in 144 data points,
- The test will be repeated 1 week after the first test, with any refinements added as needed.

Test Date(s):

- Initial test: 3/13/2021 (tentative - based of antenna shipping)
- Follow up test: 3/20/2021 (tentative)

Test Results:

Performed By: Ethan Miller, Joshua Hoye

Appendix A
BEARING COMPASS PRINTOUT

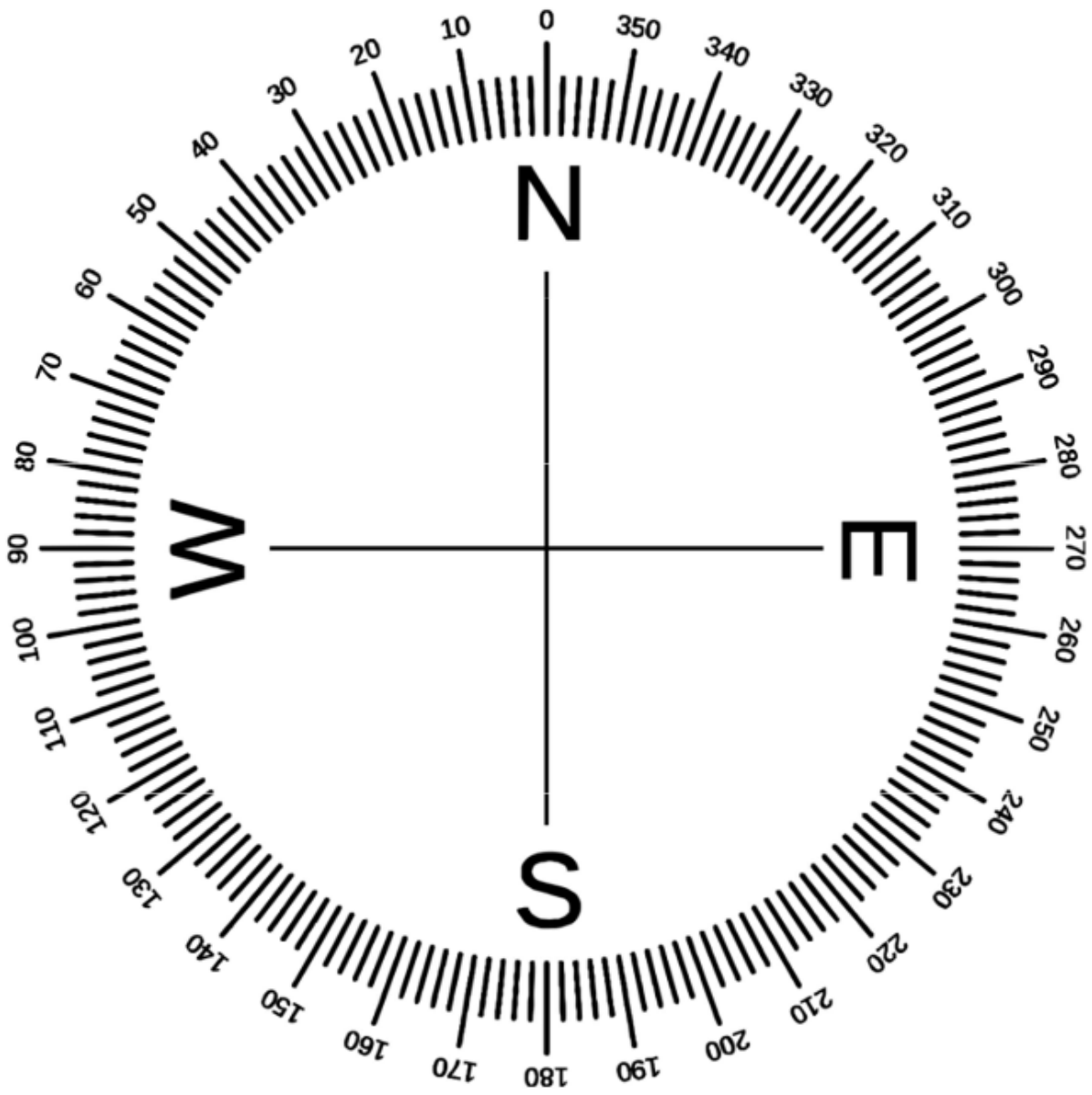

Appendix B

3D PRINTED ANTENNA LOCATING DEVICE DRAWING:

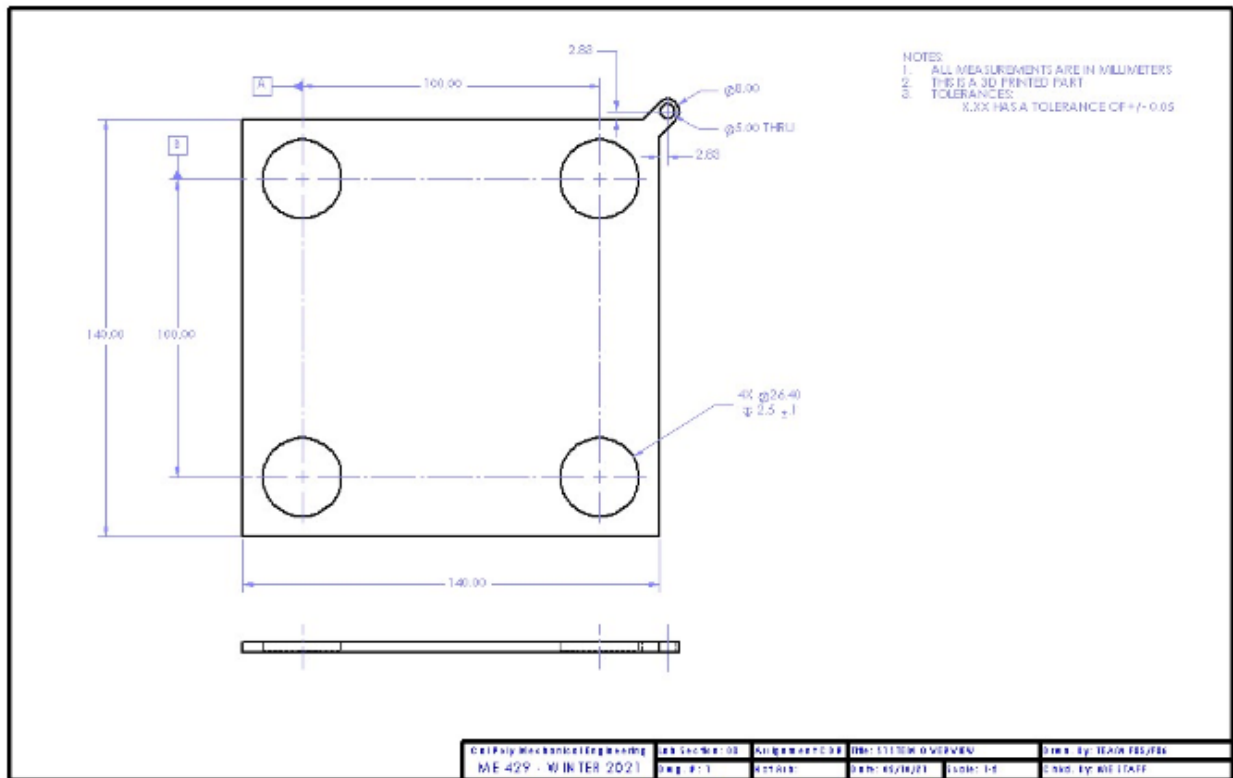

Appendix C

RADIO BEACON SETUP PROCEDURE

Part 1: HARDWARE

Hardware Needed:

- Arduino UNO R3 Microcontroller Starter Kit
- Adafruit Radio Transceiver (RFM69HCW)
- Edge mount female SMA connector
- 900MHz antenna
- Small bread board
- External 9V battery
- 9V battery to barrel jack connector

1. Solder pin connectors onto the RFM69HCW board as seen in Figure C1. Only the Vin side of the board needs to have the pin connectors, but the G ports do add stability for the device when it is in the bread board.



Figure 1. Pin connectors in RFM69HCW board.

2. Solder the edge mount female SMA connector to both sides of the board as seen in Figure C2.

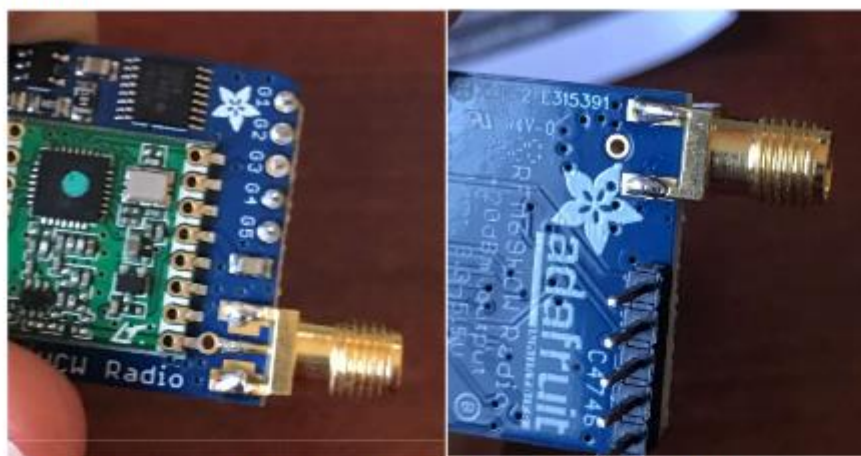

Figure C2. Soldering of SMA connector onto RFM69HCW board.

3. Connect RFM69HCW board to a small bread board as seen in Figure C3. For our device, we taped a small bread board onto the Arduino prototype shield that connects to the Arduino Uno for portability.

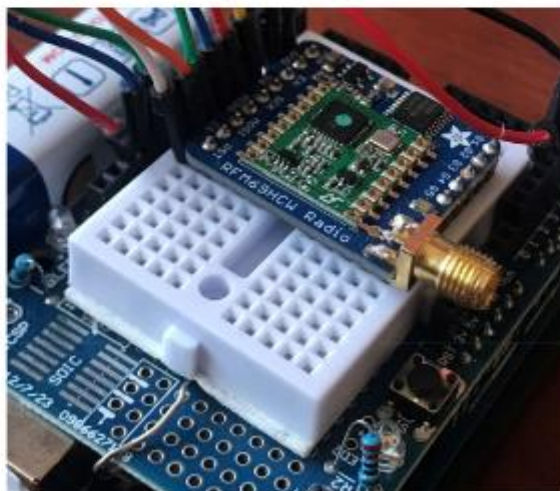

Figure C3. RFM69HCW board on a small bread board.

- Using jump wires, connect the pins on the RFM69HCW board to the Arduino Uno using the schematic in Figure C4. (Disregard the blue wire on the right side. This is for if you do not have an actual antenna.)

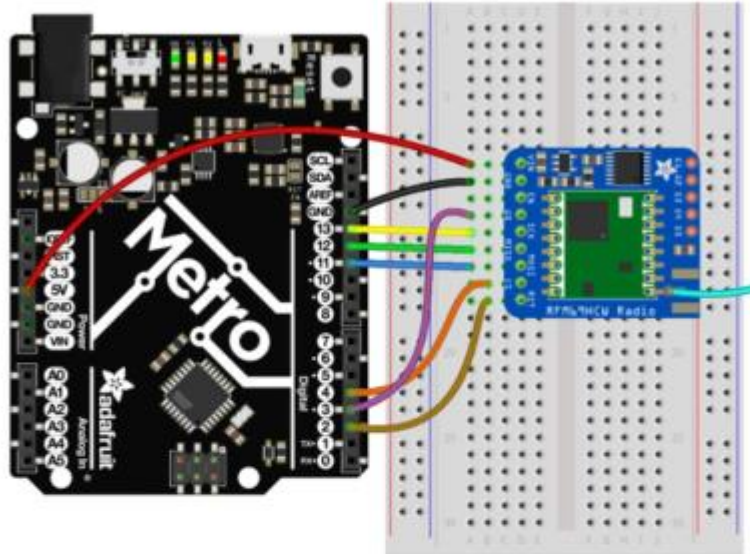

Figure C4. Wiring schematic for RFM69HCW board to the Arduino Uno.

- Connect antenna to SMA connector as seen in Figure C5.



Figure C5. Connecting antenna to SMA connector.

6. Connect 9V to barrel jack connector to 9V battery. Plug in barrel jack to Arduino Uno. Process can be seen in Figure 6C.

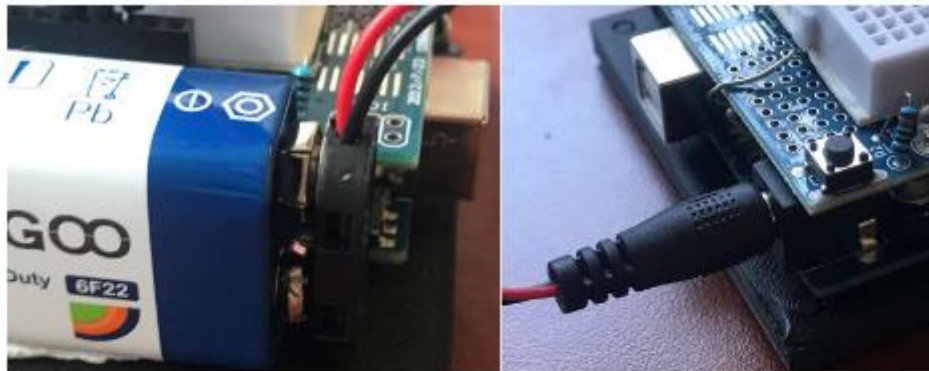

Figure C6. Connecting 9V battery to Arduino.

Part 2: SOFTWARE

1. Download software from the link below. This will allow the Arduino to constantly emit a 915Mhz signal. This board can also receive radio messages, but that application is not needed here.

Link:

https://bitbucket.org/emiller10/radio_beacon/src/master/RadioHead69_SAVER_Beacon.ino

2. Connect the Arduino to your computer through USB cable.
3. Open the downloaded file in the Arduino app and upload to the Arduino. Now, on reset, the Arduino should emit the wanted frequency constantly.

Appendix D

KERBEROS SETUP PROCEDURE

On your Linux-based system, follow the directions by Kerberos developers:

<https://www.rtl-sdr.com/ksdr>

Because some of the software is outdated, when you at the Manually Installing Software on PC section, follow the directions at this link: <https://github.com/rfjohnso/kerberossdr>

NVIDIA Jetson Stereo Camera Test Procedure:

Team: F86

Test Name: Target Detection and Ranging

Purpose: *The purpose of this test is to determine the reliability of target detection and accuracy of target depth perception of the camera system as a function of distance.*

Description of Test: *Run testing code to collect data at known distances from the camera system and analyze results.*

Test Equipment Required:

- Jetson Nano (4GB)
- Micro-USB power and sync cable
- Laptop with PuTTY installed and at least an hour of battery life or access to an outlet
- imx219-83 stereo camera
- Measuring tape
- Table or stand for holding the camera system
- Masking tape or the like for marking locations
- Adjustable helping hand for positioning the camera

Hazards

- NA

PPE Requirements:

- NA

Facility:

Any open field or lot with minimum 50 feet of open space.

Procedure:

1. Select a location for the camera system and place the stand. This location should be at one end of the field where there will be minimum interference from other objects when looking out from this position.
2. Set up camera system.

- a. Insert both csi ribbon cables from the camera module into the matching connectors on the Jetson Nano.
 - b. Use the adjustable helping hands to position the camera module. Be careful not to clamp anywhere near a component on the board lest a short be created.
 - c. Connect the laptop and jetson nano via the usb cable. A green light should appear on the Jetson and a red light should appear on the camera module.
 - d. Open the jetson terminal by opening a serial line from the laptop using PuTTY. The appropriate COM port can be found in the device manager.
 - e. Log into the jetson and cd into /SAVER_2020-2021/Testing/'Target Detection and Ranging'
 - f. Run CameraCheck.py. This will bring up a view of what the cameras see.
 - g. Position the cameras out toward the field, and verify that you can see the target's head at each distance marker.
3. Mark out distances from this location at 5 ft increments up to 50 ft using the tape measure.
 4. With a partner standing at the first mark, run ReliabilityTest.py, which is also located in /SAVER_2020-2021/Testing/'Target Detection and Ranging'.
 - a. Have your partner turn in place 90 degrees at a time, taking 10 seconds to do so and waiting 10 seconds between each turn.
 5. Stop the program, saving the video output, and record the data collected by the program. The program should output a Percent Detected, Average Confidence, Average Distance, and Distance Deviation. These are:
 - a. The percentage of frames in which the target was detected.
 - b. The average confidence interval associated with the detections.
 - c. The average estimated distance to the target.
 - d. The average difference in each distance estimation from the average.
 6. Repeat steps 4 and 5 at each distance marker.
 7. Shut down the camera system, clean up markers.

Results: Pass Criteria, Fail Criteria, Number of samples to test

Activ

- Pass criteria:
 - Percent Detected $\geq 50\%$
 - Average Confidence $\geq 25\%$
 - Average Distance = Measured distance $\pm 15\%$
 - Distance Deviation $\leq 15\%$

Fail criteria:

- Pass criteria not met.
- False positives persist through multiple frames in video replay

Test Date(s):

- Initial test: 4/10/2021
- Follow up test: 4/15/2021 (tentative)

Test Results:

Performed By: Joshua Hoye, Josephine Isaacson

GPS Test Procedure:

Team: F86

Test Name: IMU/GPS Test Procedure

Purpose: *Determine the accuracy of the position, orientation, and GPS location data for the combined IMU/GPS system*

Description of Test: *Use known GPS location data and known positions and compare the known data to the data recorded by the IMU and GPS*

Test Equipment Required:

- iPhone with GPS location data
- FGPMOPA6H GPS Standalone Module
- BNO055 IMU
- Battery
- Tape measure

Hazards

- Electrical discharge (extremely minor)

PPE Requirements:

None

Facility:

Open flat field

Procedure:

1. Establish origin for GPS
 - a. Place system on ground, use iPhone to calculate GPS coordinates of point
2. Test Changes in location
 - a. Move IMU/GPS system along 10 different points on ground
 - b. For each point, have the system calculate its expected location
 - c. For each point, record the actual location with the GPS app
 - d. Repeat measurements twice at each point (3 data points total)

Location		1	2	3	4	5	6	7	8	9	10
Reading (coordinates)	A										
	B										
	C										

Figure 1: Data log for Test

Results: Pass Criteria, Fail Criteria, Number of samples to test

- Pass criteria: Average location accuracy (all data points) is less than or equal to ± 2 meters.
- Fail criteria: Average location accuracy does not meet the values above.
- The test will be repeated 1 week after the first test, with any refinements added as needed.

Test Date(s):

- Initial test: 4/30/2021 (tentative - based of GPS shipping)
- Follow up test: 5/8/2021 (tentative)

Test Results:

Performed By: Josephine Isaacson

Appendix M: Gantt Chart

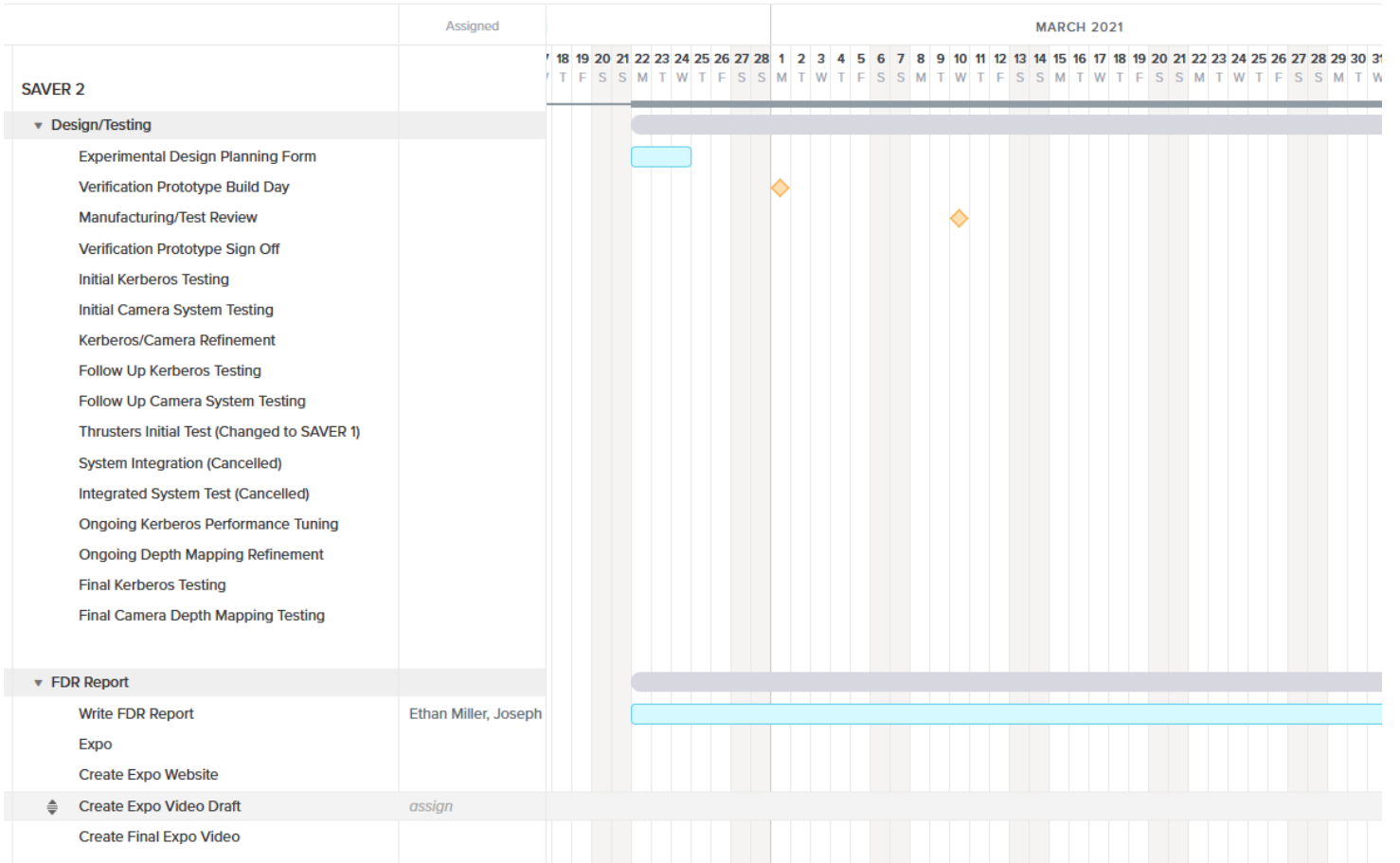

		Assigned	APRIL 2021																															
SAVER 2			31	1	2	3	4	5	6	7	8	9	10	11	12	13	14	15	16	17	18	19	20	21	22	23	24	25	26	27	28	29	30	
			W	T	F	S	S	M	T	W	T	F	S	S	M	T	W	T	F	S	S	M	T	W	T	F	S	S	M	T	W	T	F	
▼ Design/Testing																																		
	Experimental Design Planning Form		<																															
	Verification Prototype Build Day		<																															
	Manufacturing/Test Review		<																															
	Verification Prototype Sign Off																																	◆
	Initial Kerberos Testing																																	
	Initial Camera System Testing																																	
	Kerberos/Camera Refinement																																	
	Follow Up Kerberos Testing																																	
	Follow Up Camera System Testing																																	
	Thrusters Initial Test (Changed to SAVER 1)																																	
	System Integration (Cancelled)																																	
	Integrated System Test (Cancelled)																																	
	Ongoing Kerberos Performance Tuning																																	
	Ongoing Depth Mapping Refinement																																	
	Final Kerberos Testing																																	
	Final Camera Depth Mapping Testing																																	
▼ FDR Report																																		
	Write FDR Report	Ethan Miller, Joseph																																
	Expo																																	
	Create Expo Website																																	
	⚙ Create Expo Video Draft	assign																																
	Create Final Expo Video																																	

		MAY 2021																																		
		30	1	2	3	4	5	6	7	8	9	10	11	12	13	14	15	16	17	18	19	20	21	22	23	24	25	26	27	28	29	30	31	1	2	3
		F	S	S	M	T	W	T	F	S	S	M	T	W	T	F	S	S	M	T	W	T	F	S	S	M	T	W	T	F	S	S	M	T	W	T
SAVER 2																																				
▼ Design/Testing																																				
	Experimental Design Planning Form	<																																		
	Verification Prototype Build Day	<																																		
	Manufacturing/Test Review	<																																		
	Verification Prototype Sign Off	<																																		
	Initial Kerberos Testing	<																																		
	Initial Camera System Testing	<																																		
	Kerberos/Camera Refinement	<																																		
	Follow Up Kerberos Testing	<																																		
	Follow Up Camera System Testing	<																																		
	Thrusters Initial Test (Changed to SAVER 1)	█																																		
	System Integration (Cancelled)	█		█																																
	Integrated System Test (Cancelled)								█																											
	Ongoing Kerberos Performance Tuning	█																																		
	Ongoing Depth Mapping Refinement	█																																		
	Final Kerberos Testing																		█																	
	Final Camera Depth Mapping Testing																		█																	
▼ FDR Report																																				
	Write FDR Report	Ethan Miller, Joseph	█																																	
	Expo																																			
	⚙️ Create Expo Website	assign																					⊙ █													
	Create Expo Video Draft																					█														
	Create Final Expo Video																					█														