

Fuzzy Logic Based Dam Water Shutter Control System by Using Water Level and Rainfall Condition in Raining Season

Nay Thazin Htun^{a*}, Moh Moh Nyunt Aung^b

^{a,b}University of Information Technology, Yangon, Myanmar

^aEmail: naythazintun@uit.edu.mm

^aEmail: mohmohnyuntaung@uit.edu.mm

Abstract

A robust water shutter management system ensures that the water does not overflow and destroy or damage the dam. During the rainy season, care must be taken when dams conserve water, if the reservoir volume is too high, the risk of dam failure may be increased. So water level control is a special matter in the rainy season. Fuzzy logic sets provide better control than binary logic-based methods because they are used to determine the meaning of qualitative values for controller inputs and outputs, such as small, medium, and large control actions. This system used the fuzzy logic control theory in the water shutter management system to get smoothness motor control values of small, very small, medium, large, and very large. The system uses ultrasonic sensors to detect water levels, rain sensors to detect rain, and fuzzy logic controls to control the PWM duty cycle to the shutter gate motor driver circuit based on the detection of these two sensors. This control strategy is implemented with Arduino Uno.

Keywords: water shutter; Fuzzy logic; Ultrasonic sensor; rain sensor; Arduino Uno.

1. Introduction

In countries where agriculture is the mainstay, dams are very important, water is collected during the rainy season and applied irrigation in the summer. Dams provide flood control, water storage for (industrial, municipal, and agricultural), Irrigation, electrical generation, and so on. If the amount of water stored during the rainy season increases, excess water must be disposed of to reduce the risk of dam failure. Increase water discharges in the rainy season can be insufficient water supply in the summer, so it is important to have a precise drainage system based on the amount of water in the dam and the amount of rainfall conditions.

* Corresponding author.

Excess water is discharged through the tunnel, where a shutter is placed at the mouth of the tunnel, and excess water is released by opening and closing the shutter. Electronic circuit control systems are supporting information and interface with the physical world by electromechanical components, such as sensors and motors. Several types of distance measuring sensors among than ultrasonic sensor are one of very useful in the distance measuring device. In this system, the ultrasonic sensor is used for water level measuring. A raindrop sensor is used for the detection of the raining conditions. These two sensors detected values are inputs of the fuzzy logic control system and produce the PWM value for water shutter gate motor rotation. Fuzzy logic is a form of multi-valued logic in which the actual value of the variable is a real number from 0 to 1. Fuzzy logic was being used in many fields, such as control theory and artificial intelligence. The block diagram of this system is shown in figure 1.

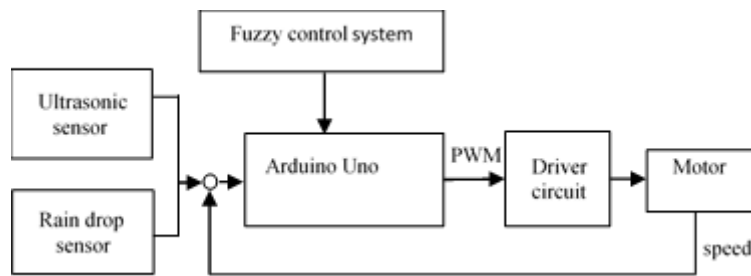

Figure 1: Block diagram of the system

2. Related Works

Benjamin Kommey and his colleagues in their system ultrasonic was used to detect the water level, GSM module sent the water level alert before the water gate open and close. The LCD is a display of the various water levels at which the device takes action. As a final warning, the buzzer sounds the alarm before the dam gates open. They implement their system on the microcontroller [1]. Sai Sreekar Siddula and his colleagues their project's basic concept is to fully automate the water level control via a central server, near all the dams by using cloud services applications IoT linked. Ultrasonic sensors are useful for getting the water level on both sides of the gate in real-time. The base station sends the data through the cloud to the central command center after collecting the information from both water sensors. They implement with Arduino circuit [2]. Mukesh Iyer and his colleagues their proposed system was used five PCB sensor circuits, each sensor using NPN transistors (BC 549) at various water levels (very low, 1/4, 1/2, 3/4, full). Various water levels are displayed on the LCD, and when the water level is above or below the minimum water level, the sensor circuit sends a trigger to the microcontroller. According to receive conditions, the microcontroller drives the motor to control the dam gate [3]. Yogesh Waghmare and his colleagues their flood warning system using the embedded controller, which implemented with 'Mikro C' Language in microcontroller Atmega 32, and the fuzzy logic algorithm is used to control the dam gate. Step by step operation of the gate is displayed by the LCD. Three different water level inputs from the Ultrasonic sensor are given to the controller and the fuzzy logic is as an algorithm to perform the controller's tasks to the floodgates motor controller unit [4]. Nilesh K. Kulkarni and his colleagues system was used a hybrid Neuro- Fuzzy approach, 5 river flow data as ANN input and runoff data as ANN output. Fuzzy logic controllers are used to using this runoff data to control reservoir gate behavior. Their design and

simulation are implemented in MATLAB [5]. Ignatio Madanhire and his colleagues its design includes a servo motor, a mechanical lifting system, and an electronic controller to monitoring water flow at all times depending on the water level. They implemented their control system based on the case study of the dam in 1970 and is situated in a rural setting, with a capacity of 10.6 mega cubic meters to store water (2800 million gallons), with servomechanism, programmable logic controllers – PLCs, and motion controllers [6]. According to mentioned review, these authors have been expressed various approaches to water level sensing, implemented in difference controllers and difference motor driving theories. Each approach had many advantages and disadvantages, therefore this system has implemented with the following factors to get a useful and accurate system.

3. Background Theory

3.1. Fuzzy logic

Fuzzy logic tries to solve problems with an open and inaccurate spectrum of data and heuristics that allow you to draw a series of accurate conclusions. Fuzzy logic is particularly suitable for systems that contain qualitative information rather than quantitative information. This applies to systems that may not have a clear value to distinguish the case being processed. Fuzzy logic produces skill values that represent the truth of a particular situation. This truth situation is a value from 0 to 1. The fuzzy controller has been used in many linear and non-linear control systems, especially in uncertain and unknown systems. In this paper water shutter motor speed is controlled by fuzzy logic theory with a measured distance of ultrasonic sensor and rain condition. A fuzzy system consists of fuzzification, rule inference, and defuzzification. For fuzzification, a triangular membership function is used and a product inference engine is used for fuzzy rule inference. For defuzzification, the weighted average method is used and the algebraic expression of the weighted average method is described as the following equation.

$$Z^* = \frac{\sum \mu_C(\bar{z}) \cdot \bar{z}}{\sum \mu_C(\bar{z})} \tag{1}$$

Membership function of distances (inputs), rain condition (inputs), and PWM duty value (output) are shown in Figures 2, 3, and 4.

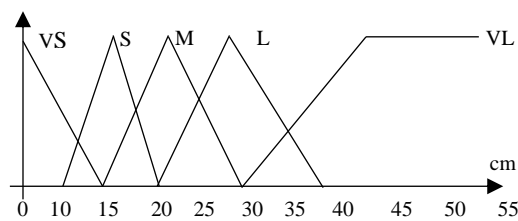

Figure 2: Membership function of Water level (input 1)

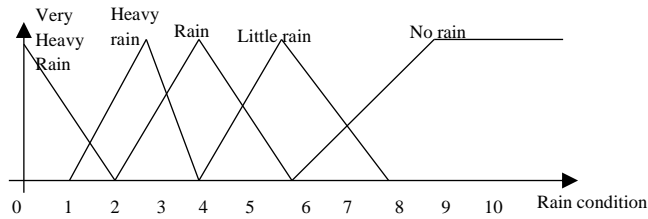

Figure 3: Membership function of rain condition (input 2)

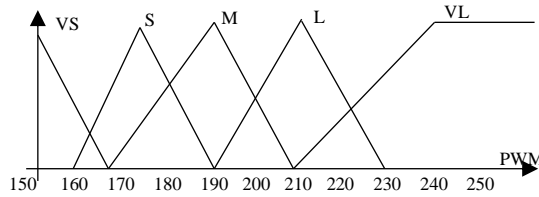

Figure 4: Membership function of PWM duty cycle valve for water shutter motor rotation (output)

To design the database of the system, five linguistic terms are used. They are VL (Very Large), L (Large), M (Medium), S (Small), and VS (Very Small). If the motor rotation is forward as an increased condition (VS to S, S to M, M to L, L to VL) else motor rotation is backward as a decrease condition (VL to L, L to M, M to S, S to VS). The rules of the system are shown in Table 1.

Table 1: Rule base for water shutter motor rotation (PWM) duty cycle value

Rain	No	A	Rain	Heavy	Very
Water	rain	Little		rain	Heavy
Level		Rain			rain
VS	L	L	VL	VL	VL
S	M	M	L	L	L
M	S	S	S	M	M
L	VS	VS	VS	S	S
VL	VS	VS	VS	VS	VS

3.2. Pulse Width Modulation (PWM)

In a microcontroller, pulse width modulation (PWM) is used to control the DC motor duty cycle. It drives the motor with a square wave of constant voltage by changing the pulse width or duty cycle. PWM can change the duty cycle of the pulse based on fuzzy control conditions. PWM signal waveform is shown in figure 5.

$$\% \text{ Duty Cycle} = \text{Pulse Width (t)} / \text{Pulse Period (T)} * 100\% \tag{2}$$

The pulse width could change by the average voltage from the microcontroller and motor was rotate based on

receipt pulse width. The wider the pulse width is the higher the average voltage and the shorter the pulse width is the lower the average voltage. Therefore, the DC motor speed could vary by the pulse width. The ratio of pulse width and pulse length is called the duty cycle, which means that the duty cycle 100% is the full speed of DC motor and the duty cycle 10% is the 10% speed of DC motor.

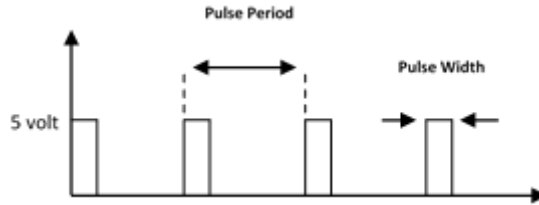

Figure 5: PWM signal

4. Design Consideration

This section describe two parts, firmware descriptions and hardware descriptions.

4.1. Firmware Description

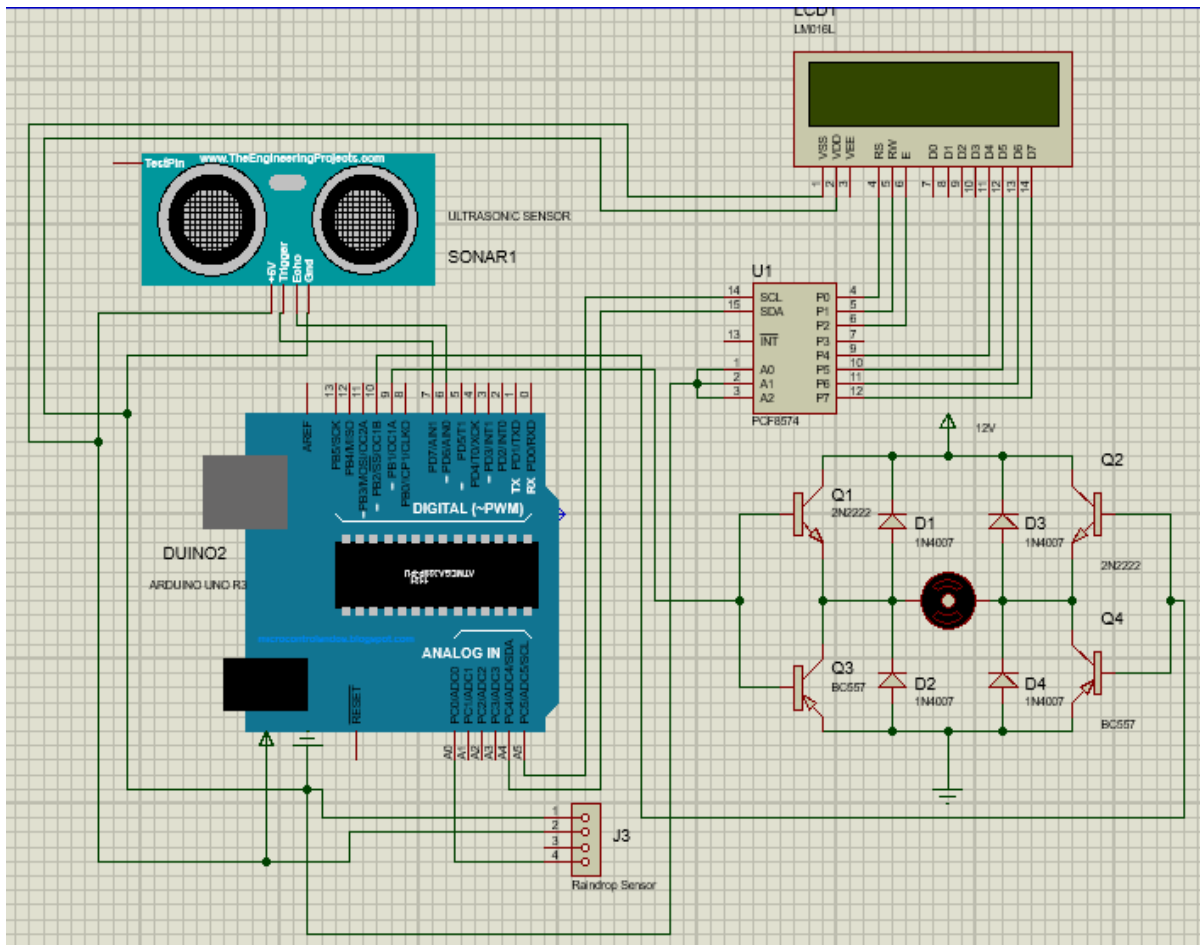

Figure 6: Circuit diagram of the overall system

Small scale model of water shutter control system design is drowned and simulate in proteus 8. The circuit design of the overall system is as shown in figure 6. The system firstly detects the distance and raindrop condition from ultrasonic sensor and raindrop sensor. Ultrasonic sensor trigger and echo pin is connected to the Arduino Uno pin 7 and 6. This two-pin perform the water level measurement. The raindrop sensor output pin is connected to the Arduino Uno A0 pin, this is used for the detection of rain conditions. Arduino A4 and A5 pins are connected with the LCD pin SDA and SCL, these used for display water level, rain condition (R), and motor rotation speed (PWM). Arduino Uno pin 10 and 9 are used for control of the high bridge motor driver circuit. If the water level is under 45 cm and the rain condition is 4, the shutter is starting open. Else the shutter is still close.

The system is start, firstly detected the water level and the rain conditions, fuzzy logic control system is calculated with these detected values and dam water shutter motors is run based on the output of the fuzzy logic control system WPM duty cycles. The system flow diagram of the fuzzy logic-based dam water shutter control system is shown in Figure 7.

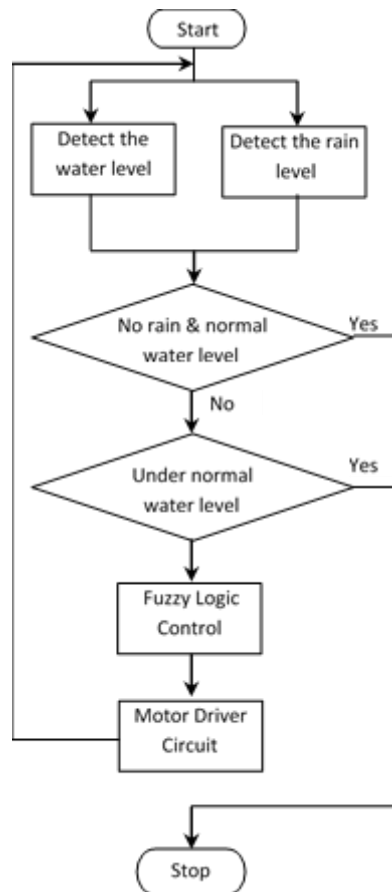

Figure 7: The system flow diagram of fuzzy logic based dam water shutter control system

4.2. Hardware Description

Following hardware parts are used to implement this systems.

4.2.1. HC-SR04 Ultrasonic sensor

The HC-SR04 ultrasonic sensor is an electronic device used in the distance measuring of an object by using SONAR. It provides excellent contactless distance detection with accurate and stable readings in the easy-to-use package from 2 cm to 400 cm or 1” to 13 feet [7].

4.2.2. Rain drop Sensor Module

Raindrop Sensor is a device for sensing rain level. It is made up of two modules: a rain board that detects rain and a control module that compares and converts the analog value to a digital value. Raindrop sensors can be used in the automobile industry to automatically manage the windshield wipers, in agriculture to detect rain, and in home automation systems.

4.2.3. I2C Liquid Crystal Display

I2C LCD module make more convenient display and is easy to use, especially with Arduino Uno. I2C LCD display module give a connection between 16x2 LCD display pins (D4, D5, D6, D7, RS, RW, E) to Arduino Uno pins (SCL, ADL). A potentiometer is built into the I2C module for contrast control and adjustment. Some of I2C LCD interfaces have pins (or solder pads) that can be changed to modify the address. They are usually labelled as A0-A1-A2. Here's how the address change from a default 0x27 or 0x3F, if connect the address pads together.

(1 = Not Connected. 0 = Connected):

Table 2: The I2C address changing

A0	A1	A2	HEX ADDRESS
1	1	1	0x27
0	1	1	0x26
1	0	1	0x25
0	0	1	0x24
1	1	0	0x23
0	1	0	0x22
1	0	0	0x21
0	0	0	0x20

4.3. H-Bridge Motor Driver Circuit

In the H-bridge motor driver's circuit, the voltage of the load is switched by a four-transistor. Diodes D1 to D4 protect the corresponding bipolar transistors by providing a safer path to remove the counter electromotive force from the motor. In this system h-bridge, the motor driver circuit is used for dam shutter moving forward and

backward. The circuit diagram of the H-bridge motor driver is shown in figure 8.

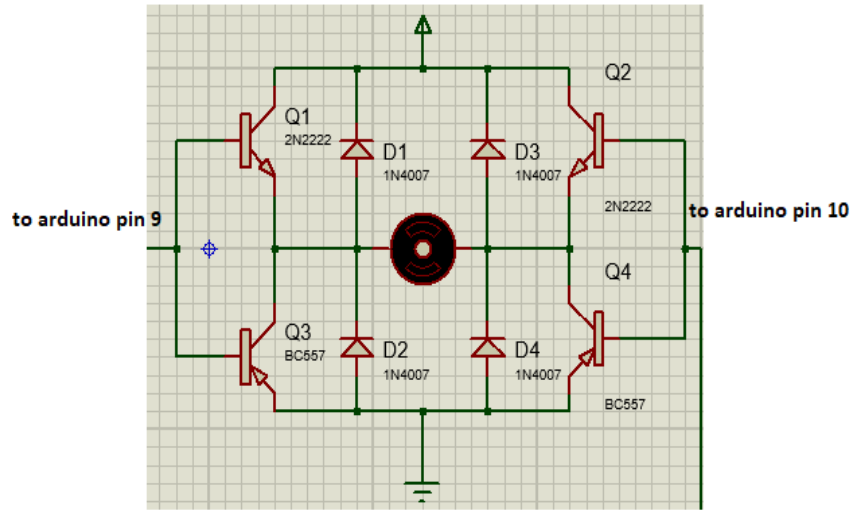

Figure 8: H-bridge motor driver circuit

5. Experimental Result

The small skill model of the dam water shutter control system is described in figure 9. The distance between the ultrasonic sensor and water is lesser, the water level is higher. If the water level distance is 55cm and below the system is starts working, even if it doesn't rain. If it raining, the fuzzy control system considers the rain condition. Rain conditions have 10 levels, 10 is no raining condition, if the rain amount is increasing, and the level number is decreasing.



Figure 9: Small Skill Model of Water Dam Shutter

6. Conclusion

The fuzzy logic-based dam water shutter control system can be useful in raining season. Another motor control system can be implemented in the dam shutter control system.

7. Farther extension and Limitation

Another sensors can be implemented in water level distance measuring such as Optical Level Switches, Capacitance, Microwave/Radar, Vibrating or Tuning Fork, Conductivity or Resistance and so on. Building a water dam shutter control system with another input, weather forecast, can be more convenient in real life. In real life, it would be more convenient to use a more accurate water level distance measuring sensors and to work with a lot of water level range specifications.

References

- [1]. Benjamin Kommey, Seth Djanie Kotey, Daniel Opoku, Ultrasonic Sensor-Based Automated Water Dam Shutter, *JITCE - VOL. 04 NO. 01 (2020)* 1-4
- [2]. Sai Sreekar Siddula, Phaneendra Babu, P.C. Jain, Water Level Monitoring and Management of Dams using IoT ,*IEEE Xplore: 05 November 2018*, 10.1109/IoT-SIU.2018.8519843
- [3]. Makesh Iyer, Shrikant Pai, Sneha Badri, Embedded Dam Gate Control System using ‘C’ and Visual Basic, *International Journal of Computer Applications (0975 – 8887)*, Volume 69– No.2, May 2013
- [4]. Yogesh Waghmare, Prakash Choudhary, Mohit Rochlani and Manisha Rajput, Fuzzy Logic Based Flood Warning and Floodgate Control System, *International Journal of Advanced Engineering and Management*, Vol. 2, No. 7, 2017, pp. 172-175
- [5]. Nilesh K. Kulkarni, Virendra V. Shete, Hybrid Neuro-Fuzzy Approach for Flood Prediction and Dam Gate Control , *International Conference on Information Society (i-Society 2014)*, *IEEE Xplore: 19 January 2015*, p-213
- [6]. Ignatio Madanhire and Munyaradzi Madaka, Design of an Automated Dam Shutter Control System: Case Study, *Proceedings of the International Conference on Industrial Engineering and Operations Management (IEOM) Paris, France, July 26-27, 2018*, p 2627