

# Performance comparison of multicarrier communication systems over doubly-selective channels

Fadhil Sahib Hasan, Noor Qaddoori Lateef

Mustansiriyah University, Electrical Engineering Department, Baghdad, Iraq

## ABSTRACT

To mitigate the effect of 5G wireless channel, new multicarrier with robust features and waveform needs to replace the conventional OFDM system. In this study, three adopted multicarrier systems are employed and compared with OFDM including FBMC, FOFDM and UFMC over 5G channel. The BER performance, PAPR and PSD are compared with OFDM system. One tap frequency domain equalizer is used with all multicarrier systems and test the performance over 5G channel. The consequences show that, FBM has the best BER at high Doppler spread and has lowest PSD. In the other side, FBMC has highest PAPR comparing with other multicarrier system.

**Keywords:** OFDM, FBMC, FOFDM, UFMC, PAPR, PSD, 5G wireless channel

### *Corresponding Author:*

Fadhil Sahib Hasan  
Mustansiriyah University  
Electrical Engineering Department  
Baghdad, Iraq  
E-mail: fadel\_sahib@uomustansiriyah.edu.iq

## 1. Introduction

Recently, Orthogonal Frequency Division Multiplexing (OFDM) stands for the most research interest of digital communication techniques such as asymmetric-digital-subscriber-line (ADSL), digital-video-broadcasting-cable (DVB-C), IEEE 802.11 and IEEE 802.16 wireless standards, long-term-evolution-advanced (LTE-advanced), and 5G [1], due to high information rate transmission, immunity against multipath fading channel and can be implemented in a sufficient way [2]. In other words, many requirements are needed for recent technological progress such as enhanced mobile broadband, low latency communication, internet-of-things (IOT), and so on. These requirements pushed to study on the new multicarrier system with high mobility, low out-of-band (OOB) property, low peak-to-average-power ratio (PAPR) and immunity against time and frequency offset [3], [4].

Several multicarrier modulation techniques are studied to mitigate these requirement like Filter Bank Multicarrier (FBMC) [5], [6], [7], Generalized Frequency Division Multiplexing (GFDM) [8], Universal Filtered Multicarrier (UFMC) [9],[10], Filtered OFDM (FOFDM) [11], [12], Polynomial Cancellation Coded OFDM (PCC-OFDM) [13]. In FBMC, each subcarrier is passing through a filtering functionality that leads to improve the spectral efficiency and reduced the OOB emission. Also, FBMC uses offset QAM (OQAM) instead of QAM in which the real and imaginary samples are isolated. Different pulse shaping filters are used such as Root Raised Cosine (RRC), PHYsical layer for DYnamic AccesS (PHYDYAS), Hermite, and Isotropic Orthogonal Transform Algorithm (IOTA) filters. Among all of them, Hermite filter has the best time and frequency localization and bit error rate performance [14]. In UFMC, each block of subcarrier is filtering instead of filtering each subcarrier as FBMC, no cyclic prefix guard is needed in this modulation. In this modulation, the PAPR is reduced comparing with OFDM since the bandwidth is grouped into subbands and fewer number of subcarrier is adding compared with OFDM [15]. The disadvantage of UFMC is more complicated comparing with OFDM. In FOFDM, the transmitter OFDM signal is passing through a windowed filter, where window function is multiplied by the linear phase filter. Different window function can be used such as Hanning,

Hamming, Kasier, Blackman, and Chebyshev window [11]. Both FBMC and FOFDM can be used to reduce OOB emission by selecting the suitable shaping filters [2]. GFDM depends on filter bank theory in similar way with FBMC where both depends on building the prototype filter. But instead linear filtering, circular filtering is used in GFDM. The performance of GFDM is similar to FBMC in terms of quasi-orthogonality, OOB emission and PAPR but with high complexity [16]. In [17], a comparison is established between OFDM and FBMC/OQAM over doubly selective fading channels. The study carried out that FBMC is outperform OFDM in spectral efficiency and BER performance, but some other comparisons are missing here such PAPR comparison.

In this paper, the comparisons between OFDM, FBMC, FOFDM and UFMC are investigated over 5G communication system with one tap equalizer. The BER performance of the systems were investigated over 5G Vehicular and Pedestrian channel models. The PAPR and power spectral density comparisons are also presented. The remaining paper is organized as: the schemes of multicarrier systems are presented in section II. The results and discussion are presented in section III. Finally, the conclusion is depicted in IV.

## 2. Multicarrier communication system

### 2.1. OFDM communication system

The plot of OFDM system is shown in Figure 1. Typically, a bit stream is mapped to a quadrature amplitude modulation (QAM) symbol in the OFDM transmitter, called  $Y$ . Then this stream of constellation symbols goes through a serial to parallel converter. Shape a collection of  $N$  parallel QAM complex signal  $Y_0, Y_1, \dots, Y_{N-1}$  reflecting increasing subcarrier's transmitted symbols. By modulating these symbols on the transmitting side with the inverse Fast Fourier Transform (IFFT), a discrete multicarrier baseband symbol is generated with cyclic extended guard interval, which can be written as [18]:

$$y(n) = F^{-1}\{Y[i]\} = \frac{1}{\sqrt{N}} \sum_{i=0}^{N-1} Y_i e^{j\frac{2\pi}{N}ni}, \quad -N_g \leq n \leq N-1, \quad (1)$$

where the number of subcarriers is act by  $N$ ,  $N_g$  is the number of guard samples. Also, a QAM detection symbols is obtained at the reception using Fast Fourier Transform (FFT). The recovered sequence after removed the cyclic prefix signal is

$$\hat{Y}_i = F\{Y[n]\} = \frac{1}{\sqrt{N}} \sum_{n=0}^{N-1} y[n] e^{-j\frac{2\pi}{N}ni}, \quad 0 \leq i \leq N-1, \quad (2)$$

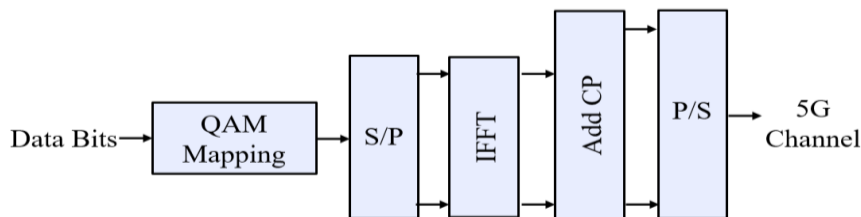

a. OFDM transmitter system

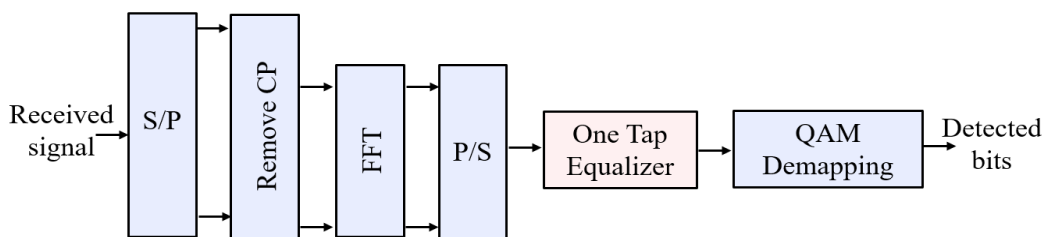

b. OFDM receiver system

Figure 1. OFDM system

## 2.2. FBMC/OQAM system

The transceiver scheme of FBMC/OQAM is plotted in Figure 2. At the transmitter side, the information bits is passing through QAM mapping and the  $k$ -th subcarrier of the  $l$ -th time,  $a_k(l)$ , is obtained. To obtain offset QAM (OQAM) signal, OQAM pre-processing stage is required. The complex signal  $a_k(l)$  is converted to real signal using complex-to-real conversion and separated to new two signals  $d_k(n)$  and  $d_k(n+1)$ . The complex to real transform is different for even and odd numbered sub-channels and can be written as

$$d_k(n) = \begin{cases} \text{Re}(a_k(l)), & k \text{ even} \\ \text{Imag}(a_k(l)), & k \text{ odd} \end{cases} \quad (3)$$

$$d_k(n+1) = \begin{cases} \text{Imag}(a_k(l)), & k \text{ even} \\ \text{Re}(a_k(l)), & k \text{ odd} \end{cases} \quad (4)$$

where  $\text{Re}(\cdot)$  and  $\text{Imag}(\cdot)$  are real and imaginary part of the signal, respectively. The signal  $d_k(n)$  is multiplied by  $\theta_k(n) = j^{k+n}$  to obtain the orthogonal symbols. The OQAM signal,  $x_k(n)$ , is expressed as

$$x_k(n) = d_k(n)\theta_k(n) \quad (5)$$

In this case the sampling rate of  $d_k(n)$  is double that of an OQAM signal. The synthesis filter bank of FBMC is implemented with efficient design using polyphase filter branches. The OQAM signal is multiplied by the phase  $\beta_k(n)$  and then taking IFFT transform. The transmitted signal of a FBMC/OQAM modulation is written as [6], [19]

$$s(m) = \sum_{k=0}^{M-1} \sum_{n=-\infty}^{\infty} x_k(n)\beta_k(n)p_k(m - n\frac{M}{2})e^{j\frac{2\pi}{M}km} \quad (6)$$

where  $M$  is the sub-channel number,  $\beta_k(n)$  is the  $k$ -th subcarrier and  $n$ -th time of the phase multiplier which is expressed as [21]:

$$\beta_k(n) = (-1)^{kn} e^{-j\frac{2\pi}{M}k(\frac{Lp-1}{2})} \quad (7)$$

Also,  $L_p$  is the prototype filter length,  $p(m)$  is prototype filter. There are different prototype filters, the best one is Hermite filter that depends on Hermite polynomials  $H_n(\cdot)$  [20]

$$p(m) = \frac{1}{\sqrt{T_0}} \exp\left(-2\pi\left(\frac{m}{T_0}\right)^2\right) \sum_{i=\{0,4,8,12,16,20\}} \varphi_i H_i\left(2\sqrt{\pi}\frac{m}{T_0}\right) \quad (8)$$

where the parameters  $\varphi_i$  are  $\varphi_0=1.412692577$ ,  $\varphi_4=-3.0145 \cdot 10^{-3}$ ,  $\varphi_8=-8.8041 \cdot 10^{-63}$ ,  $\varphi_{12}=-2.2611 \cdot 10^{-9}$ ,  $\varphi_{16}=-4.4570 \cdot 10^{-15}$ ,  $\varphi_{18}=1.8633 \cdot 10^{-16}$ .  $H_n(e)$  of order  $n$  can be calculated from the recursive relations [14]:  $H_0(e)=1$ ,  $H_{n+1}(e)=2e H_n(e) - \dot{H}_n(e)$ , where  $\dot{H}_n(e)$  is the derivative of  $H_n(e)$  with respect to  $e$ .  $T_0$  is a time-scaling parameter that based on subcarrier spacing. All the operations is reversed in the receiver side as shown in Figure (2-b) to detect the original transmitted bits.

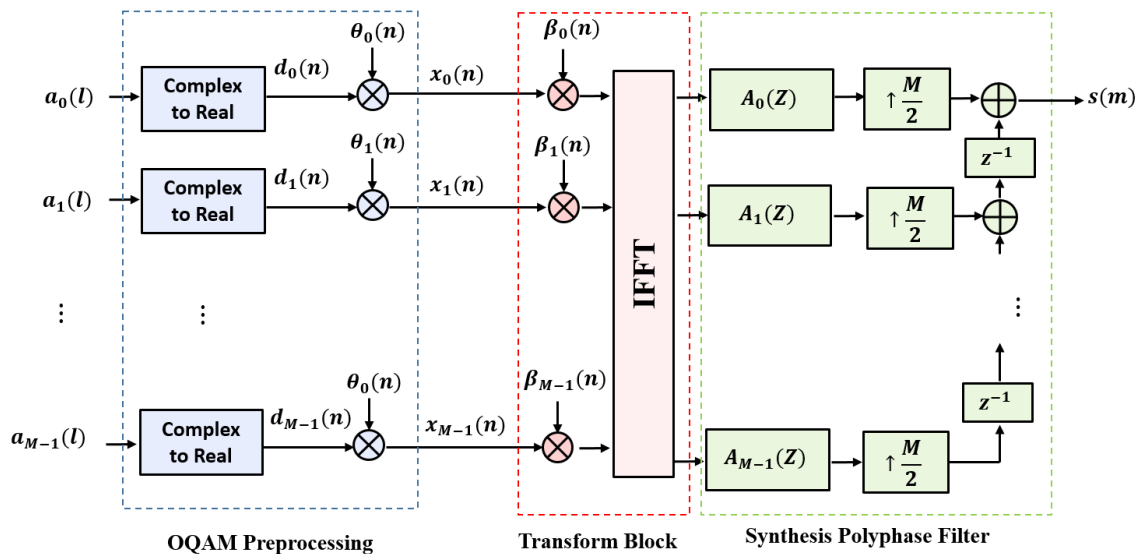

a. FBMC transmitter system

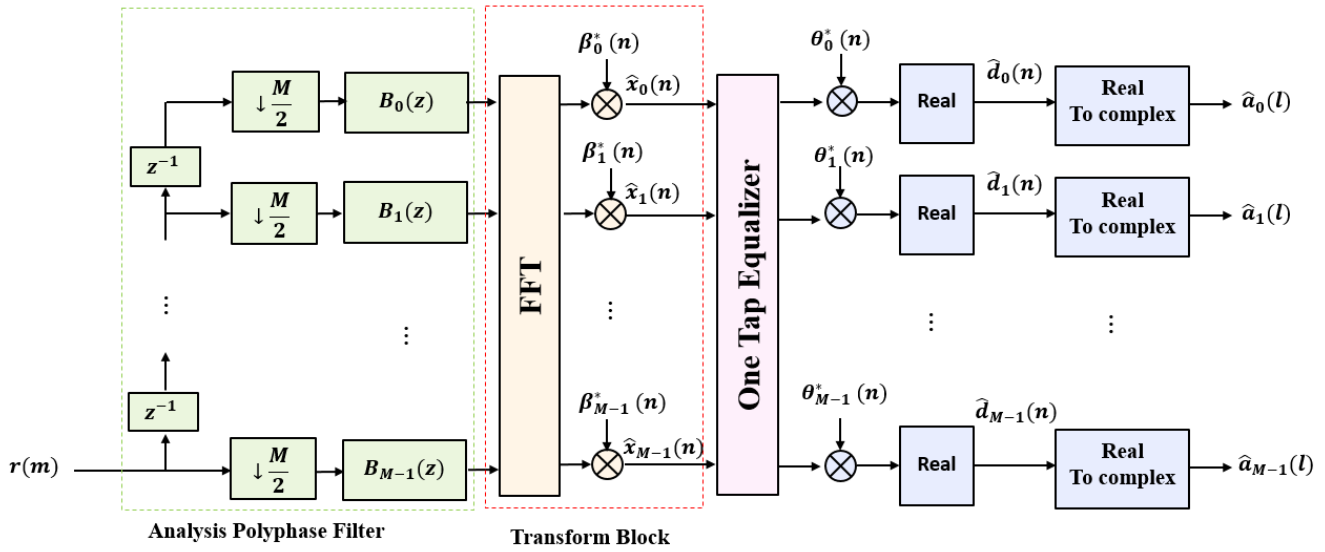

b. FBMC receiver system  
 Figure 2. FBMC communication system

### 3. FOFDM communication system

The block diagram of FOFDM transceiver system is illustrated in Figure 3. It is clear that the FOFDM system is identical to OFDM system except that the FOFDM transmitted signal,  $s_f(m)$ , is obtained by convolve the transmitted OFDM sequence,  $s(m)$ , with a filter sequence  $f(m)$  as [11]:

$$s_f(m) = s(m) * f(m) \quad (9)$$

where  $*$  is the convolution function and  $f(n)$  is a FIR filter and is written as:

$$f(m) = f_a(m) w(m) \quad (10)$$

where  $f_a(m)$  is the ideal linear phase filter and  $w(m)$  is window function. Different window functions can be used such as Hamming, Hanning, Kaiser, Chebyshev or Blackman window [11]. In this paper Hanning window is used.

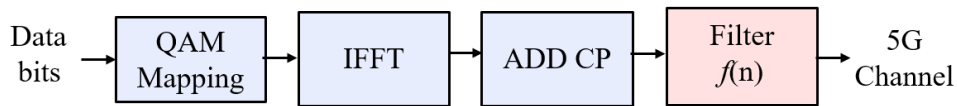

a. FOFDM transmitter system



b. FOFDM receiver system

Figure 3. FOFDM communication system

#### 4. UFMC Communication System

UFMC has the features of OFDM, FBMC, and FOFDM in which blocking a full range of OFDM system into sub-bands without needing to cyclic prefix. The scheme of transceiver UFMC system is illustrated in Figure 4 [15]. At the transmitter, the input data is converted to  $B$  sub-blocks, QAM mapping is used to convert the data bits into symbol level,  $S_{i,k}$ ,  $i = 1, \dots, B$ ,  $k=0, \dots, N-1$ . Each output of sub-block is passed through  $N$  point IFFT representing with  $V_{i,k}$ ,  $i = 1, 2, \dots, B$ ,  $k = 0, \dots, N-1$ . The output of IFFT will be serialized and passing through filter representing with  $F_{i,k}$ ,  $i=1, \dots, B$ ,  $k=0, \dots, N-1$ . The filter used in this paper, is Dolph-Chebyshev window filter with order  $L$  [9], in this work 60 dB side lobe attenuation is used. The transmitted signal of UFMC is expressed as [15]:

$$s_k = \sum_{i=1}^B F_{i,k} \cdot V_{i,k} \cdot S_{i,k} \quad (11)$$

At the reception side, the received signal is passing through FFT function and then one tap frequency domain equalizer is taken for each subband. Finally, QAM demapping is used to detect the original bits.

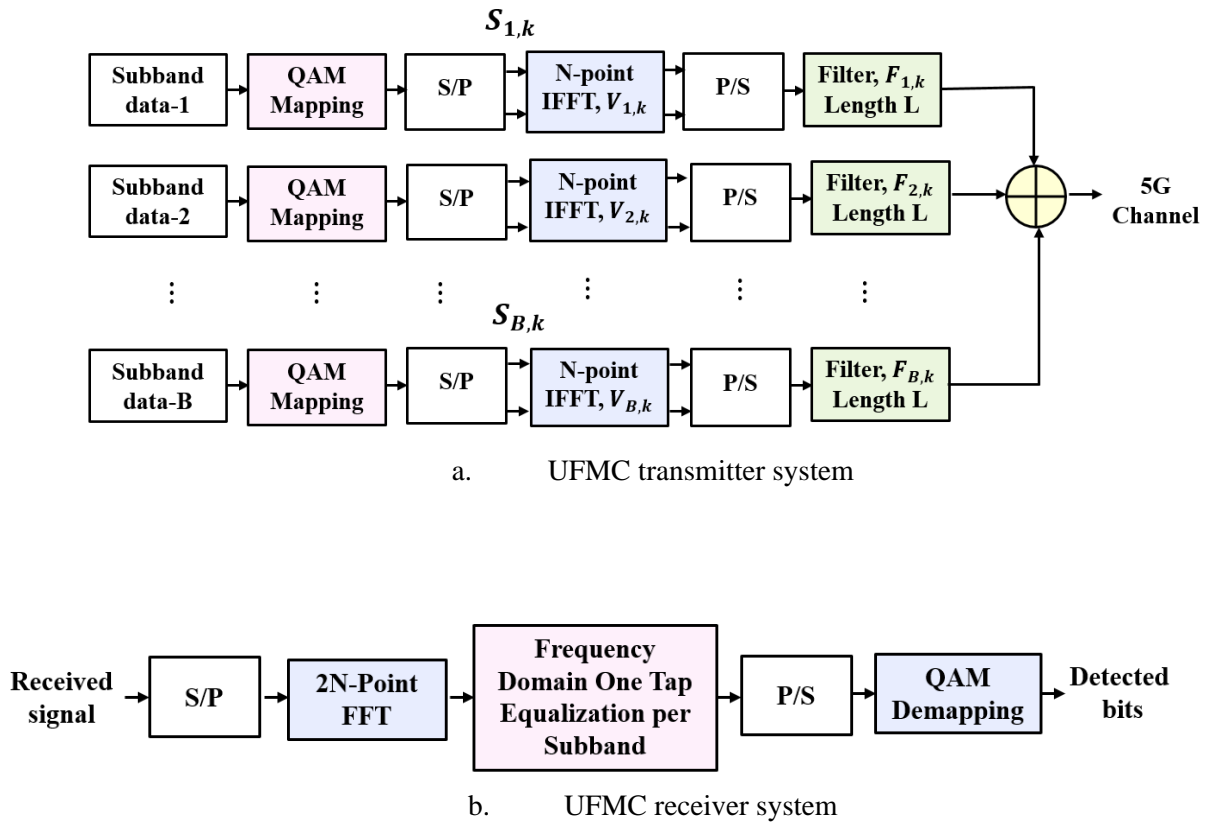

Figure 4. UFMC communication system

#### 5. One-Tap channel equalizer

In multicarrier transmissions, the reception sequence of the  $l$ -th time and  $k$ -th subcarrier is decomposed by:

$$r_{l,k} = h_{l,k} s_{l,k} + n_{l,k} \quad (12)$$

Since the imaginary interference is orthogonal to the desired sequence, it has no effect on the performance. Then, a simple one-tap Zero-Forcing (ZF) equalizer obeyed by nearest-neighbor-detection is represented by [21]

$$\hat{s}_{l,k} = \frac{y_{l,k}}{h_{l,k}} \quad (13)$$

## 6. Simulation results

In this simulation, OFDM, FBMC, FOFDM, and UFMC modulations are investigated and compared using MATLAB 2018. The comparison is made using BER, PAPR, and PSD measures. Two types of 5G channel are used: vehicular channel model A that is the fast fading channel and pedestrian channel model B that is slow fading channel. The channel Model parameters is listed in Table 1. Table 2 shows the main parameters of the simulation.

Table 1. Channels model parameters

Path number	Vehicular channel model A		Pedestrian channel model B	
	Relative delay (ns)	Average power (dB)	Relative delay (ns)	Average power (dB)
1	0	0	0	0
2	310	-1	200	-0.9
3	710	-9	200	-4.9
4	1090	-10	1200	-8.0
5	1730	-15	2300	-7.8
6	2510	-20	3700	-23.9

Table 2. Simulation parameters

Parameters	OFDM	FBMC	FOFDM	UFMC
Modulation/Order	QAM 4,16,64,256	OQAM 4,16,64,256	QAM 4,16,64,256	QAM 4,16,64,256
FFT size /Subcarrier	256/200, 512/300	256/200, 512/300	256/200, 512/300	256/200, 512/300
Prototype Filters	-	Hermite	Hanning window	Dolph-Chebyshev window
Overlapping Factor	-	4	-	-
Cyclic Prefix Length ( $\mu sec$ )	4.7619	0	0	0
Subcarrier spacing (kHz)	15	15	15	15
Channel Model	Vehicular-A/ Pedestrian-B Jakes Model	Vehicular-A/ Pedestrian-B Jakes Model	Vehicular-A/ Pedestrian-B Jakes Model	Vehicular-A/ Pedestrian-B Jakes Model
Velocity (km/h)	10, 200,500	10, 200,500	10, 200,500	10, 200,500
Carrier frequency (GHz)	2.5	2.5	2.5	2.5

Figure 5 depicts the BER comparisons between different MC techniques over AWGN channel, Subcarrier =200 and QAM levels 4, 16, 64, 256. It can be seen that the behavior of FBMC, FOFDM and UFMC are approximated identical and outperform the performance of OFDM in slightly. Also, increase the order of QAM will degrade the BER performance of the systems. Figure 6 shows the BER comparisons between MC systems over Vehicular-A channel with subcarriers 200, 64 QAM and different velocities. From this figure, the BER of FOFDM and UFMC systems are approximated the same of that OFDM. At low velocity (10 km/h), FBMC appears to be the worst one comparing with others but with high velocity FBMC BER becomes the best. In high velocity, one tap equalizer becomes inefficient and need another stronger equalizer. Figure 7 plot the BER performance comparisons between MC systems over Pedestrian-B channel with 20 km/h velocity, 200

subcarriers and different levels of QAM. The figure shows the priority of OFDM comparing with the others. UFMC better than both FOFDM and FBMC and the behavior of FBMC and FOFDM approximately the same. The CCDF comparisons between different MC systems are illustrated in Figure 8 for 200 subcarriers and different levels of QAM. Figure 9 shows the CCDF comparisons for different subcarriers. From these figures, it can be seen that FBMC has the largest PAPR and OFDM has the lowest PAPR. FOFDM has approximately the same PAPR as OFDM. UFMC has lower PAPR than FBMC. Increasing either the order of QAM or subcarrier number will increase the PAPR value for all MC systems. Figure 10 shows the PSD comparisons between different MC systems with 64 QAM and 24 subcarrier number. It can be seen that, FBMC has the lowest PSD comparing with other systems.

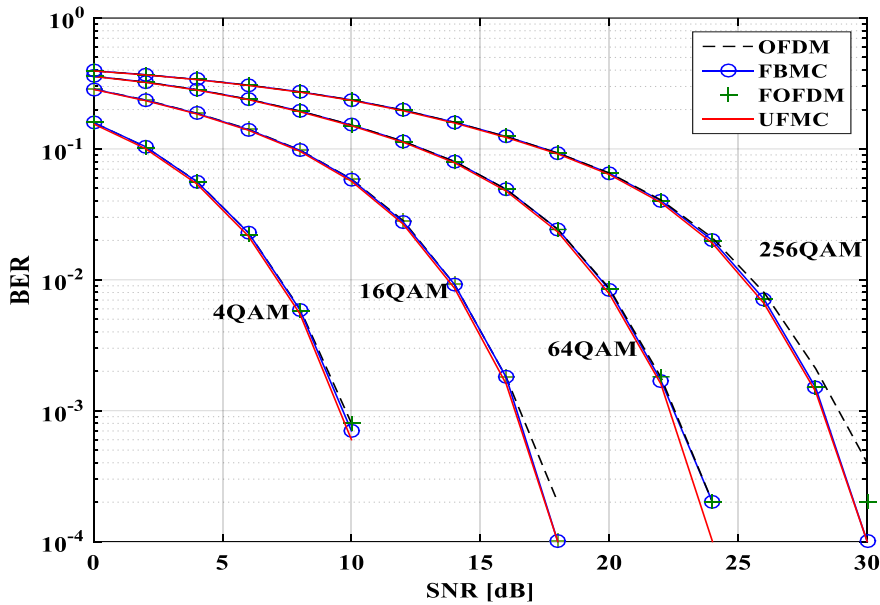

Figure 5. BER comparisons of MC over AWGN for subcarrier=200 and 4, 16, 64 and 256 QAM

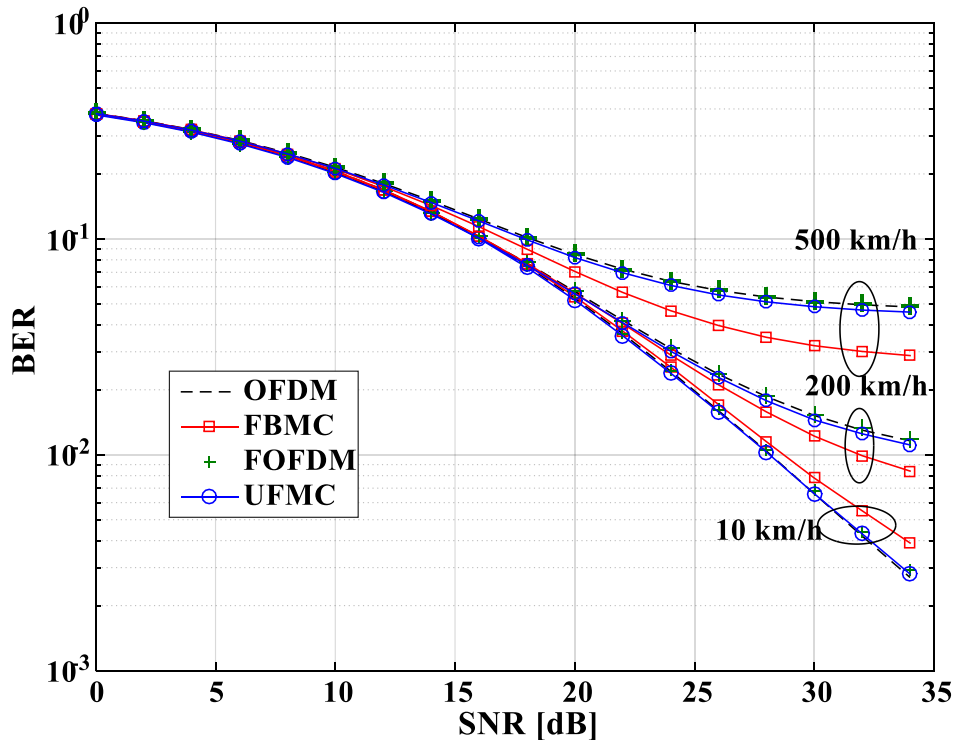

Figure 6. BER comparisons of MC systems over Vehicular-A channel for subcarrier=200, 64 QAM and velocities 10, 200, 500 km/h

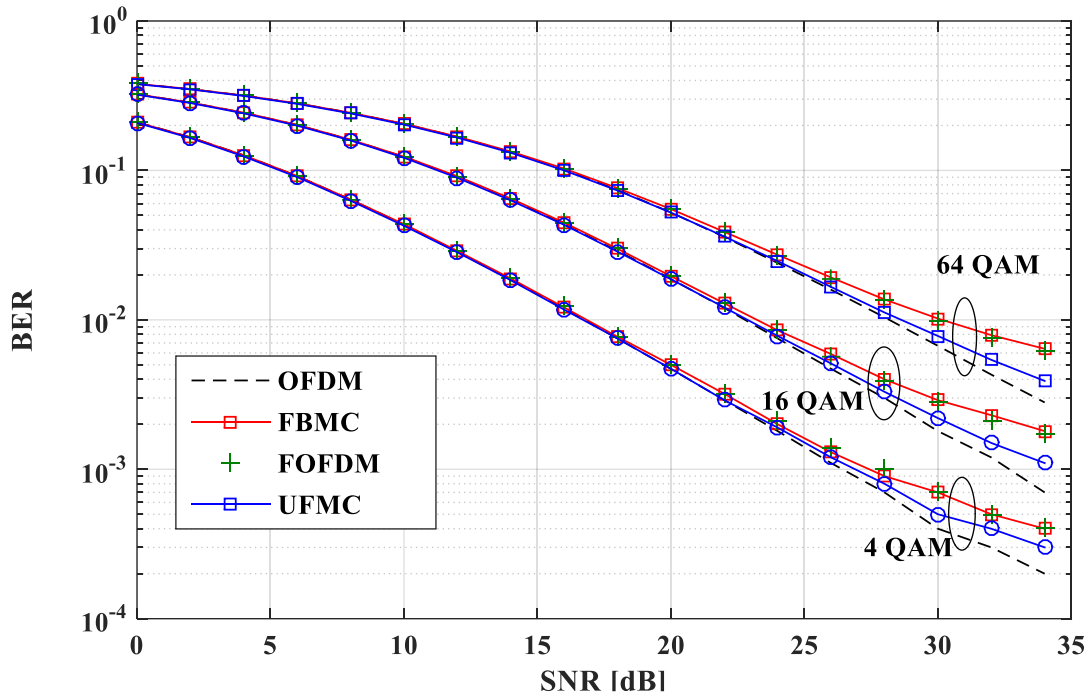

Figure 7. BER comparisons of MC systems over Pedestrian-B channel for subcarrier=200, velocity 10 km/h and 4, 16, 64 QAM.

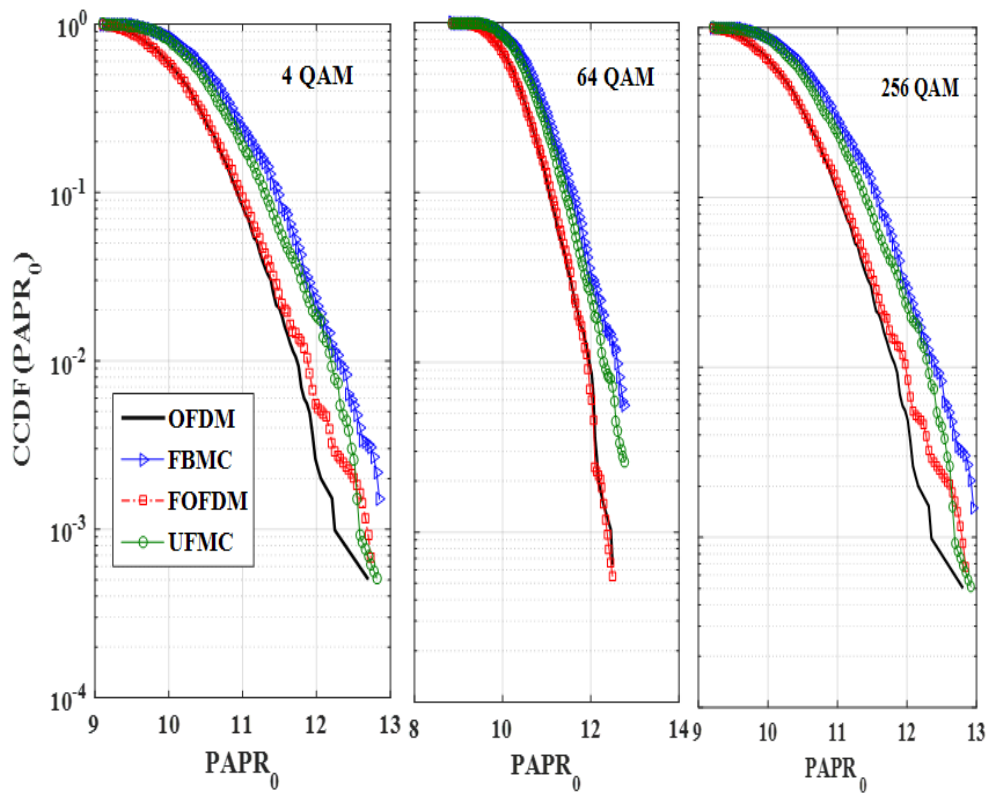

Figure 8. CCDF comparisons between MC systems for 4, 64, 256 QAM and 200 subcarriers



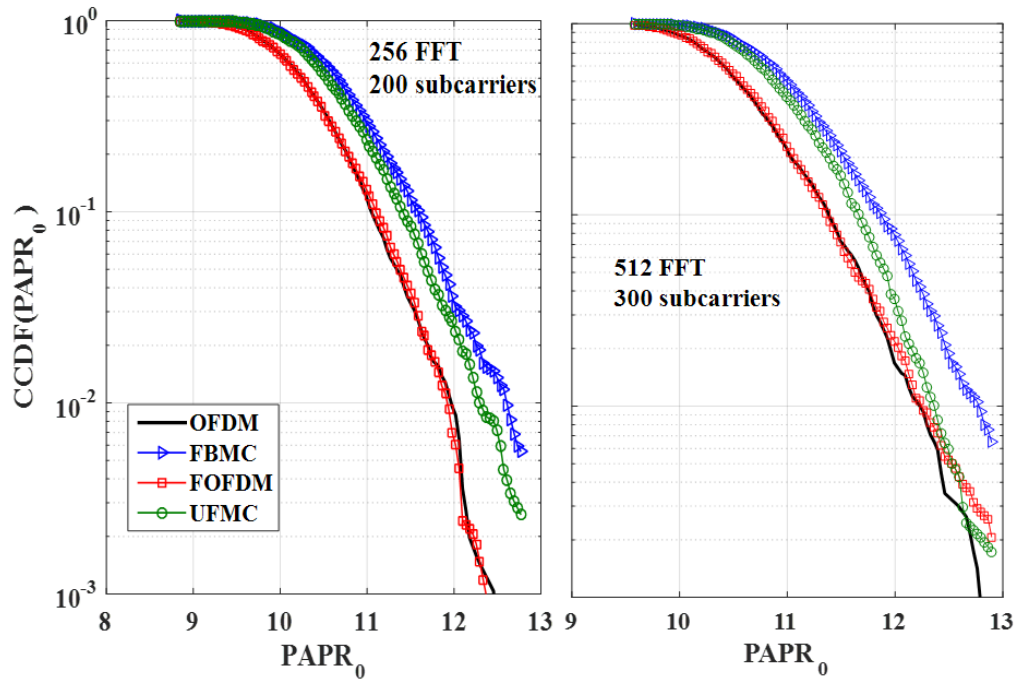

Figure 9. CCDF comparisons between MC systems for 64 QAM and 200, 300 subcarriers.

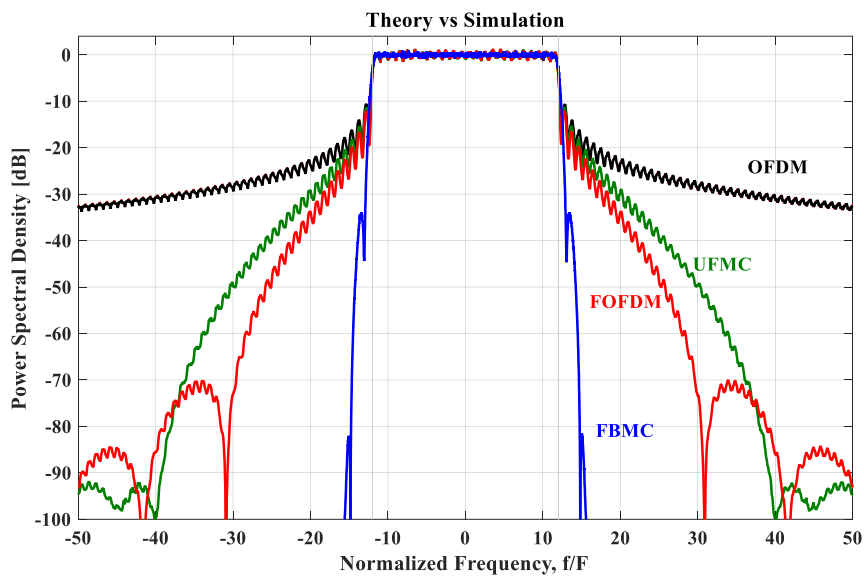

Figure 10. PSD comparisons between MC systems for 64 QAM and 24 subcarriers

## 7. Conclusion

In this paper, the comparisons and parametric investigations between different multicarrier systems including OFDM, FBMC, FOFDM and UFMC are carried out across 5G channels. The comparisons is made using BER performance, PAPR and PSD analysis. Two channels are taken that are Vehicular-A and Pedestrian-B channel with different scenarios and parameters. The results show that FBMC has the best BER at high velocities and the best PSD comparing with other MC systems. Also, FBMC has the worst PAPR than other MC systems.

## References

- [1] 3GPP. Study on New Radio Access Technology Physical Layer Aspects. (Release 14). Available online: <http://www.3gpp.org/DynaReport/38802.htm> (accessed on 19 June 2020).

- [2] X. Yang, S. Yan, X. Li, F. Li, "A Unified Spectrum Formulation for OFDM, FBMC, and F-OFDM", *Electronics*, vol.9, pp. 1–15, 2020.
- [3] P. Banelli, S. Buzzi, G. Colavolpe, A. Modenini, F. Rusek and A. Ugolini, "Modulation Formats and Waveforms for 5G Networks: Who Will Be the Heir of OFDM?: An overview of alternative modulation schemes for improved spectral efficiency", *IEEE Signal Processing Magazine*, vol.31, no.6, 80-93, 2014.
- [4] G. Kongara, C. He, L. Yang, and J. Armstrong<sup>1</sup>, "A Comparison of CP-OFDM, PCC-OFDM and UFMC for 5G Uplink Communications," *IEEE Access*, vol. 4, pp. 1–15, 2016.
- [5] B. Farhang-Boroujeny, "OFDM Versus Filter Bank Multicarrier," *IEEE Signal Processing Magazine*, vol. 28, no. 3, pp. 92–112, 2011.
- [6] B. Farhang-Boroujeny, "Filter Bank Multicarrier Modulation: A Waveform Candidate for 5G and Beyond," *Advances in Electrical Engineering*, vol. 2014, pp. 1–25, 2014.
- [7] M. Bellanger, "FBMC physical layer: a primer," PHYDYAS, 2010.
- [8] N. Michailow, M. Matthe, I. S. Gaspar, A. N. Caldevilla, L. L. Mendes, A. Festag, and G. Fettweis, "Generalized Frequency Division Multiplexing for 5th Generation Cellular Networks," *IEEE Transactions on Communications*, vol. 62, no. 9, pp. 3045–3061, 2014.
- [9] V. Vakilian, T. Wild, F. Schaich, S. T. Brink, and J. Frigon, "Universal Filtered Multi-Carrier Technique for Wireless Systems Beyond LTE," *IEEE Globecom Work*, pp. 223–228, 2013.
- [10] R. T. Kamurthi, "Review of UFMC Technique in 5G," 2018 International Conference on Intelligent Circuits and Systems (ICICS), pp. 115–120, 2018.
- [11] X. Cheng, Y. He, B. Ge, and C. He. "A filtered OFDM using FIR filter based on window function method." In 2016 IEEE 83rd Vehicular Technology Conference (VTC Spring), pp. 1-5. IEEE, 2016.
- [12] L. Zhang, A. Ijaz, P. Xiao, M. M. Molu, and R. Tafazolli, "Filtered OFDM Systems, Algorithms, and Performance Analysis for 5G and Beyond," *IEEE Transactions on Communications*, vol. 66, no. 3, pp. 1205–1218, 2018.
- [13] G. Kongara, C. He, L. Yang, and J. Armstrong, "A Comparison of CP-OFDM, PCC-OFDM and UFMC for 5G Uplink Communications," *IEEE Access*, vol. 4, pp. 1–22, 2016.
- [14] M. K. A.-H. Hadi and T. Ziboon, "Comparative Study of Pulse Shaping Filters in FBMC," *Communication, Control and System Eng. (IJCCCE)*, vol. 19, no. 2, pp. 30–40, 2019.
- [15] K. P. Kishore, P. R. Umar, and V. J. Naveen, "Comprehensive Analysis of UFMC with OFDM and FBMC," *Indian Journal of science and Technology*, vol. 10, no. 17, pp. 1–7, 2017.
- [16] I. B. F. D. Almeida, GFDM as a framework for FBMC-OQAM: iterative detection and performance evaluation, *MSC Thesis, Instituto Nacional de Telecomunicações–INATEL*, 2018.
- [17] A. M. Imran, A. A. Hassan, and Khan, "5G waveform competition: performance comparison and analysis of OFDM and FBMC in slow fading and fast fading channels," *LNNS*, vol. 69, pp. 51–67, 2020.
- [18] K. Fazel, *Multi-Carrier and Spread Spectrum Systems*. England: John Wiley & Sons Ltd, 2003.
- [19] M. Bellanger, Prototype filter and filter bank structure. Technical Report, PHYDYAS Project, 2009.
- [20] R. Haas and J. C. Belfiore, "A time-frequency well-localized pulse for multiple carrier transmission," *Wireless Personal Communications*, vol. 5, no. 1, pp. 1–18, 1997.
- [21] R. Nissel, *Filter Bank Multicarrier Modulation for Future Wireless Systems*, Austria, 2017.