

Comparison of FLC and ANFIS Methods to Keep Constant Power Based on Zeta Converter

Neily Itsqiyah Mufa'ary^{1,a}, Indhana Sudiharto^{1,b}, and Farid Dwi Murdianto^{1,c,*}

¹Departement of Electrical Engineering, Politeknik Elektronika Negeri Surabaya, Jl. Raya ITS, Keputih Sukolilo 60111, Indonesia

^aneilyitsqiyah@gmail.com, ^bindhana@pens.ac.id, ^{c,*}farid@pens.ac.id (Corresponding Author)



Abstract—The rapid development of technology encourages humans to always create various types of renewable innovations, which are useful for facilitating work and fulfill user's order as desired. Especially in household appliances that use renewable energy sources in the form of solar cell, this implementation produces a fluctuating output power according to the properties of solar cell. So, it needs to be stabilized by zeta converter with the help of technology in the engineering sector, it is carried out by means of an interface as a liaison between the software and the controlled hardware. Therefore, a fuzzy set theory emerged to solve the problem in control design. However, there are other controls that can improve fuzzy deficiencies, called ANFIS. ANFIS has advantages in the learning process from the plant and the rules that will be made by the Neural Network have the main ability in terms of learning and adaptation, then decision making is done by FLC. This paper aims to compare the performance of the FLC and ANFIS as a control to keep stability of the output power of the zeta converter, where the converter work like a buck-boost converter that can increase or decrease the output power to be consumed in order to stabilize. The use of these two controllers can also compare the time at steady state and the constant power before learning occurs and after learning process. The simulation results show that the accuracy of ANFIS is 99.82% higher than accuracy of FLC which is 98.08%.

Keywords—*FLC, ANFIS, Zeta Converter*

I. Introduction

Researchers are interested in fuzzy system both in theory and practice [1]. The characteristic of fuzzy logic and neural network can develop adaptability, flexibility and rapidity. The fuzzy logic has good interpretive ability, but low adaptability. On contrary, neural network can approach all types of nonlinear function, but it requires a lot of learning data that is difficult to construe. ANFIS is a Sugeno type Fuzzy Inference System (FIS) which has many applications in various area, such as functional approaches, intelligent control and time series prediction [2]. The results of the design and testing the

FIS and ANFIS [3] systems have better performance than fuzzy logic systems.

In the last few years, fuzzy logic has been proposed as new artificial intelligent which result still show an oscillation on steady state response [4]. In addition, fuzzy logic is more difficult to determine the membership function. This can be solved by using ANFIS, where the domain determination of the membership function and the fuzzy rule base is done automatically. However, before designing ANFIS it is important to know that the fuzzy logic be composed of three parameters, namely error, delta error and output. The performance of the control and the best response power is determined by the selection of the number and membership function, which in this paper use the triangle function and 5×5 membership functions.

In this paper, we have discussed the comprehensive probationary analysis of FLC and ANFIS to keep constant power based on zeta converter scheme. This novel research work mainly focuses on comparison algorithm of FLC and ANFIS for constant power will provide greater efficiency, fast responses, and a flexible design that is reliable under a variety of setting points.

II. Research Methodology

In this paper, comparison of FLC and ANFIS methods to keep constant power will find from output DC-DC converter. Then, this experiment is carried out shown in Figure 1. This is perform to decide the output power of the converter that has controlled by FLC or ANFIS so that the output power becomes constant.

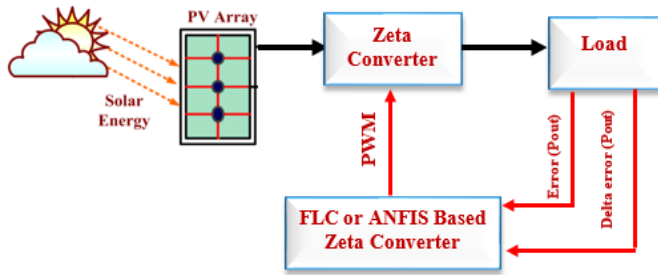

Figure 1. The Overall Methods of System

ANFIS takes the full advantages of its two algorithm, namely fuzzy logic has the ability to transform the qualitative appearance of human consciousness and ideas into the process of accurate measurable inspection and ANN has a greater ability in the development of learning to familiarize themselves with the environment [5]. Therefore, to reduce the error rate in determining rules of fuzzy logic, its obligatory to use ANN. An adaptive network that practices the learning process is an ANFIS structure, which has a membership function in the TSK fuzzy inference system. The input method is the power error and the delta error which is represented by triangle functions and the output signal is duty cycle. Finally, the duty cycle is used to stabilize the zeta converter in order to produce constant power.

A. Zeta Converter Modeling

Zeta converter is a converter that produces a low output voltage ripple and has non-reversed polarity. This converter is seemed as buck-boost converter [6]. Zeta converter circuit consist of two inductors and series capacitor, sometimes called a coupling capacitor [7]. The basic circuit of zeta converter is shown in Figure 2. The zeta converter design is used to increase or decrease the output power as hoped. Therefore, to design a zeta converter required the parameters shown in Table 1.

The principle of zeta converter on the basic switching on off codition is divided into two modes. Mode-1 shown Figure 3, the converter operates when switch is turned on L_1, L_2 are charged through V_s , and D become reverse biased. Futhermore, for mode-2 shown in Figure 4. When switch is turned off L_2 with C_2 energizes the load while the energy stored by the passive components is released [8].

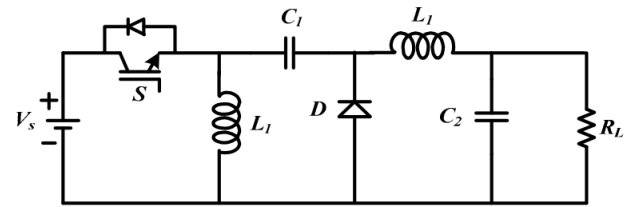

Figure 2. Zeta Converter Circuit

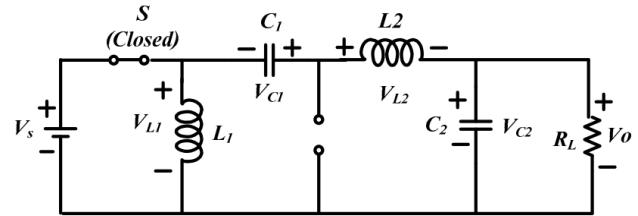

Figure 3. The On-Mode Circuit of Zeta Converter

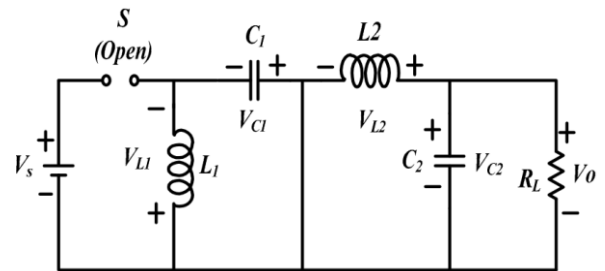

Figure 4. The Off-Mode Circuit of Zeta Converter

Table 1. Zeta Parameters

Parameter	Value
Frequency Switching	100 kHz
Input Voltage	75 V
Input Current	16 A
Output Voltage	220 V
Output Current	3.8 A
Current Ripple	20%
Voltage Ripple	0.1%

From the zeta parameters as shown in Table 1, the value of zeta converter can be calculated using the equation below:

$$D = \frac{V_{out}}{V_{out} + V_{in}} \tag{1}$$

$$R = \frac{v_{out}}{i_{out}} \tag{2}$$

$$\Delta I_{L(PP)} = K \times I_{in} \tag{3}$$

$$L_{1a} = L_{1b} = \frac{1}{2} \times \frac{V_{in} \times D}{\Delta I_{L(pp)} \times f_{sw}} \tag{4}$$

$$I_{L_{1amax}} = I_{in} + \frac{\Delta I_L}{2} \tag{5}$$

$$I_{L_{1bmax}} = I_{out} + \frac{\Delta I_L}{2} \tag{6}$$

$$C_{out(min)} = \frac{D}{8 \times \Delta V_{C_{out}} \times f_{sw}} \tag{7}$$

$$C_{in(min)} = \frac{D \times I_{out}}{\Delta V_{C_{in}} \times V_{in} \times f_{sw}} \tag{8}$$

$$C_c = \frac{D \times I_{out}}{\Delta V_{C_c} \times V_{out} \times f_{sw}} \tag{9}$$

Where:

- V_{in} = Input voltage
- V_{out} = Output voltage
- I_{in} = Input current
- F_{sw} = Frequency switching
- ΔI_L = Ripple inductor current
- D = Duty cycle
- $I_{L_{max}}$ = Inductor current maximum

The frequency switching used to minimize inductance value of L_1 and L_2 is 100 kHz. By using high-frequency, the zeta converter output wave will be smooth. The overall calculation of zeta converter is shown below:

Table 2. Zeta Design Parameter

Component	Symbol	Value	Unit
Resistor	R	62	Ω
Inductor 1	L_1	91	μH
Inductor 2	L_2	91	μH
Input Capacitor	C_{in}	470	μF
Coupling Capacitor	C_c	220	μF
Output Capacitor	C_o	22	μF

B. FLC Modeling

Fuzzy logic is similar to the human being's feeling and inference processes [9]. Rule base and fuzzy set of linguistic variables involved are the basis of fuzzy logic [10]. In this paper the authors simulate a zeta converter based system for constant power using fuzzy logic with

the Sugeno inference system method which is displayed with the help of MATLAB as a calculation. In the calculation of fuzzy logic, there are three stages that must be passed, namely: (1) *fuzzification*; (2) *inference engine*; (3) *defuzzification* [11].

1) Fuzzification

Fuzzification is a process of changing value (crisp input) into a membership function. at this stage, the value of the input variable consisting of error and delta error is called input Crisp, while the output variable is a duty cycle. The following is a Figure 5 of the relationship between the input and output variables.

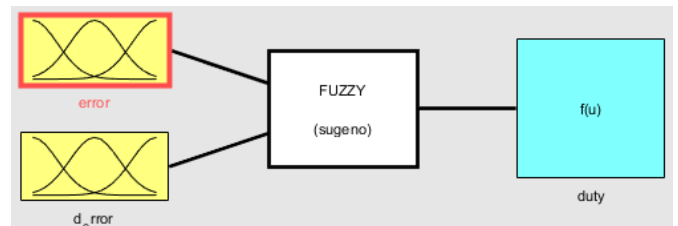

Figure 5. Variable Input and Output

The formula for determining the value of μ (miu) or membership function of each variable using the triangle shown in Figure 6 [12].

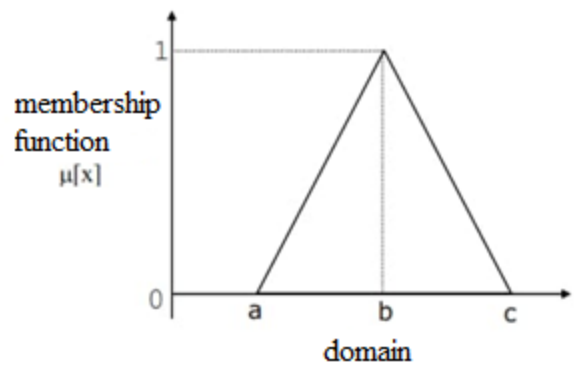

Figure 6. Triangular Membership Function

From this representation the membership function for triangular curve using the equation below:

$$\mu[x, a, b, c] = \begin{cases} 0; & x \leq a \text{ or } x \geq c \\ \frac{x-a}{b-a}; & a \leq x \leq b \\ \frac{c-x}{c-b}; & b \leq x \leq c \end{cases} \tag{10}$$

Where:

- a = the smallest domain value that has zero membership function
- b = the value of a domain that has a membership function of one
- c = the largest value of the domain that has zero membership function

From the representation of Figure 6, the entries for membership levels are drawn as straight lines. This form is the simplest and is a good option for approaching an unclear concept. There are two states of a linear fuzzy set, namely linear ascending and linear descending.

a. *Linear Ascending*

The linear up in the set starts at the value of the domain which membership function is zero [0] move right to the value domain that has a higher membership function is 1 which is called an ascending linear function representation. The representation of the membership function for linear ascension is as follows:

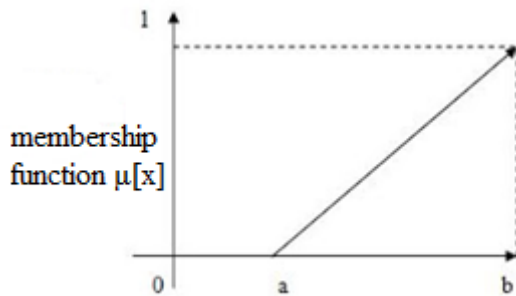

Figure 7. Representation of Membership Function for Linear Ascension

b. *Linear Descending*

The linear down function is the opposite of the linear up function. The straight line starts from the value of the domain with the highest membership function of 1 on the left, then goes down to the value of the domain with the lower membership function of 0. The representation of the membership function for linear descending is as follows:

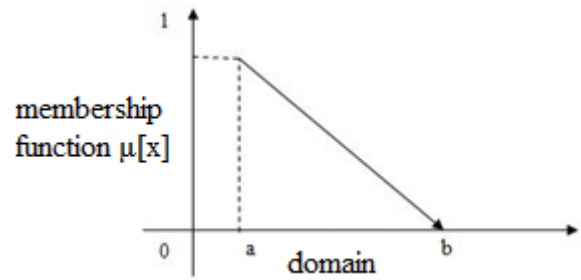

Figure 8. Representation of Membership Function for Linear Descending

2) *Inference Engine*

Inference Engine in determining the output duty cycles with the error and delta error variables. There are 25 rules obtained, as shown in Table 3 in this system the MIN method is used, where taking the minimum value from the rule base is the solution, then it is used to modify the fuzzy area, and apply it to the output using the AND operator. If problems have been evaluated, the output will reflect the contribution of each problem to the fuzzy rule base. The rules determine the input and output membership functions that will be in the linguistic inference process and also the rules have the right to "IF-THAN".

Table 3. Rule Base FLC

Error / Delta Error	NB	NS	Z	PS	PB
NB	NB	NS	NS	NS	Z
NS	NS	NS	NS	Z	PS
Z	NS	NS	Z	PS	PS
PS	NS	Z	PS	PS	PB
PB	Z	PS	PS	PB	PB

3) *Defuzzification*

The input of the defuzzification process is in the form of a fuzzy set obtained from the arrangement of fuzzy rules, while the resulting output is a number in the domain of the fuzzy set in the form of a duty cycle. In this Sugeno type, defuzzification process using weighted average.

C. ANFIS Controller Modeling

Neuro-fuzzy is the first orde Sugeno model that integrated fuzzy logic system and neural network. A neuro-fuzzy system is an artificial neural networks system based on fuzzy interfaces which is trained using a learning algorithm [13]. To simplicity the fuzzy inference system, we assume it has two inputs x and y and one output z [14]. The format rule base of TKS type:

$$\text{if } x_1 \text{ is } A_1 \text{ and } x_2 \text{ is } B_1 \text{ then } y_1 = p_1 x_1 + q_1 x_2 + r_1 \quad (11)$$

$$\text{if } x_1 \text{ is } A_2 \text{ and } x_2 \text{ is } B_2 \text{ then } y_2 = p_2 x_1 + q_2 x_2 + r_2 \quad (12)$$

Where x_1 and x_2 are the crisp inputs, A_i, B_i are linguistic variables shown in Figure 10. ANFIS architecture which consist of five layers can be explained as follows [15]:

1) *Layer -1 (Fuzzification)*: On this layer represents fuzzy membership function as node function with an adaptive parameters.

$$O_{1,i} = \mu_{A_i}(x), \quad i = 1,2 \quad (13)$$

where x is input value, $O_{1,i}$ is membership value of fuzzy variable A_i , a_i, b_i, c_i are the premise parameters.

2) *Layer -2 (Product)*: At this layer is to arrange the nodes using operator of a t-norm prod. This layer integrates with layer 1 and the multiplies all incoming signals and then sends the product out. Every layer node serves measure of the strength rule. Output on this layer work as a weighting function. The output of the product stated in equation below:

$$O_{2,i} = w_i = \mu_{A_i}(x) \cdot \mu_{B_{i-2}}(x) \text{ for } i = 1,2 \quad (14)$$

3) *Layer -3 (Normalization)*: The weights function obtained from layer 2 products is normalized for each layer. The calculation of the output is carried out normally as in the equation (15):

$$O_{3,i} = \bar{w}_i = \frac{w_i}{w_1 + w_2}, \quad i = 1,2 \quad (15)$$

4) *Layer-4 (Defuzzification)*: At this layer has nodes that are adaptive. The calculation of the defuzzification output of this layer is shown in equation (16):

$$O_{4,i} = \bar{w}_i \cdot f_i = w_i(p_i x + q_i y + r_i) \quad (16)$$

where \bar{w}_i is the output of *layer-3* and $\{p_i, q_i, r_i\}$ are adaptive consequent parameters.

5) *Layer-5 (Total Output)*: This layer is the total output node layer which is integrated with layer 4 and returns the overall output using the fixed function as in (17).

$$O_{5,i} = \sum \bar{w}_i \cdot f_i = \frac{\sum w_i f_i}{\sum w_i} \quad (17)$$

ANFIS training is carried out with a hybrid learning algorithm which consist of two steps, namely feed forward and backward pass. Especially, in the feed forward of the hybrid learning algorithm, node output go to forward until *layer-4* and the consequent parameters are recognized from the least squares method. In the backward pass, the premise parameters are updated by gradient seed and error signal head backward.

The flowchart of ANFIS is shown in Figure 9. Data set for input the ANFIS is error and delta error, then data set for output is duty cycle. in this paper each mf consist of 5x5 triangles as shown in Figure 11-13. ANFIS is a controller that integrated fuzzy system and neural network system is shown in Figure 10. As with neural network, ANFIS collects data that is used for the training process. The training data is generated from the zeta converter output power during close loop simulation of FLC, which has thousands of data. After getting a constant power value, output of ANFIS will be exported into the simulation system. Futhermore running the simulation system, so that errors obtained will continue being processed in generating PWM duty cycle for switching on zeta converter.

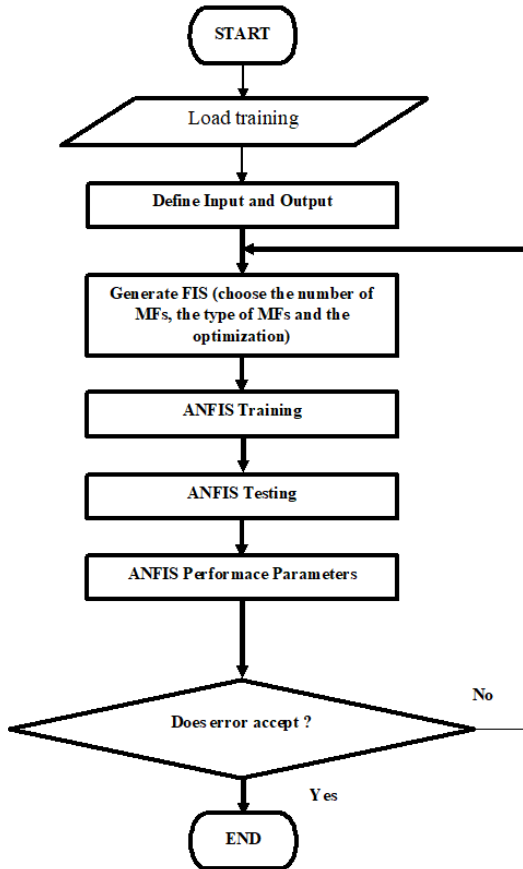

Figure 9. Flowchart of ANFIS

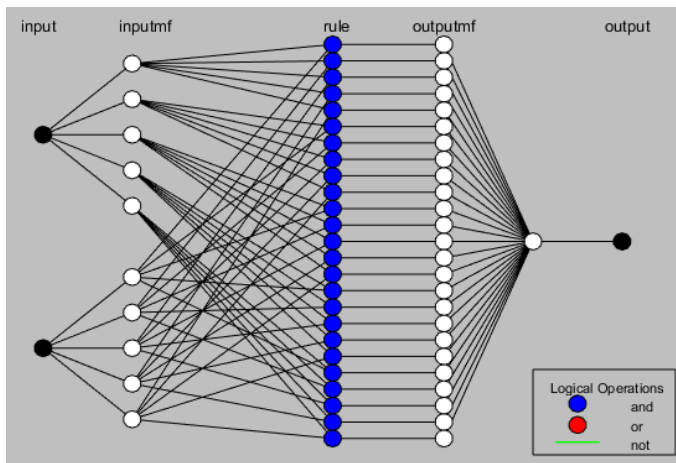

Figure 10. Structure of ANFIS

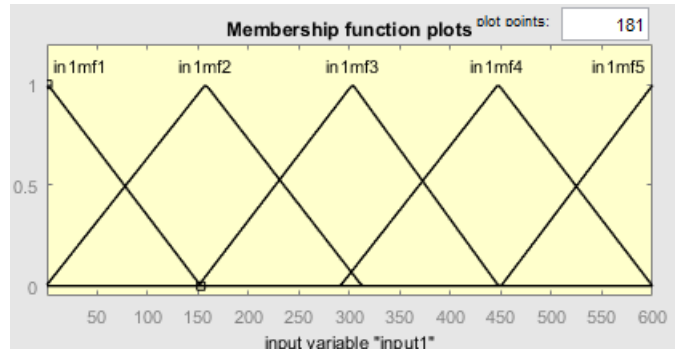

Figure 11. Error Membership Function of ANFIS

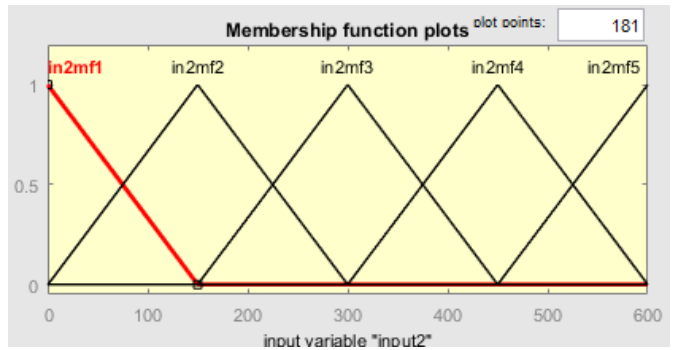

Figure 12. Delta Error Membership Function of ANFIS

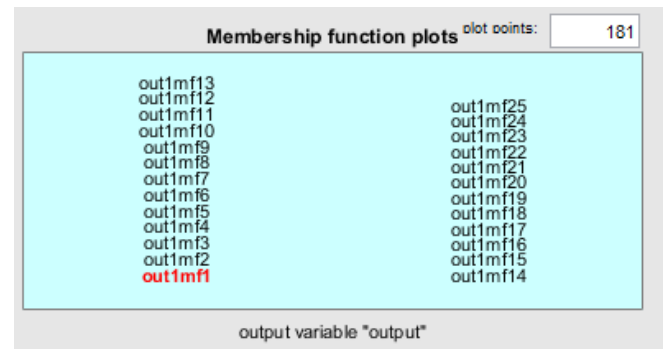

Figure 13. Membership Function Output of ANFIS

III. Results and Discussion

The simulation of MATLAB software is doing simulation test the FLC and ANFIS performed using 8 PVs for supply the system, where the value each PV is 100 Wp and the configuration is 4 series and 2 parallel shows in Figure 14. The performance analysis is conducted on the basis of time compulsive to learn parameters of FLC from data error, delta error and duty. Also learn parameters of ANFIS controller from training data, training error and testing error.

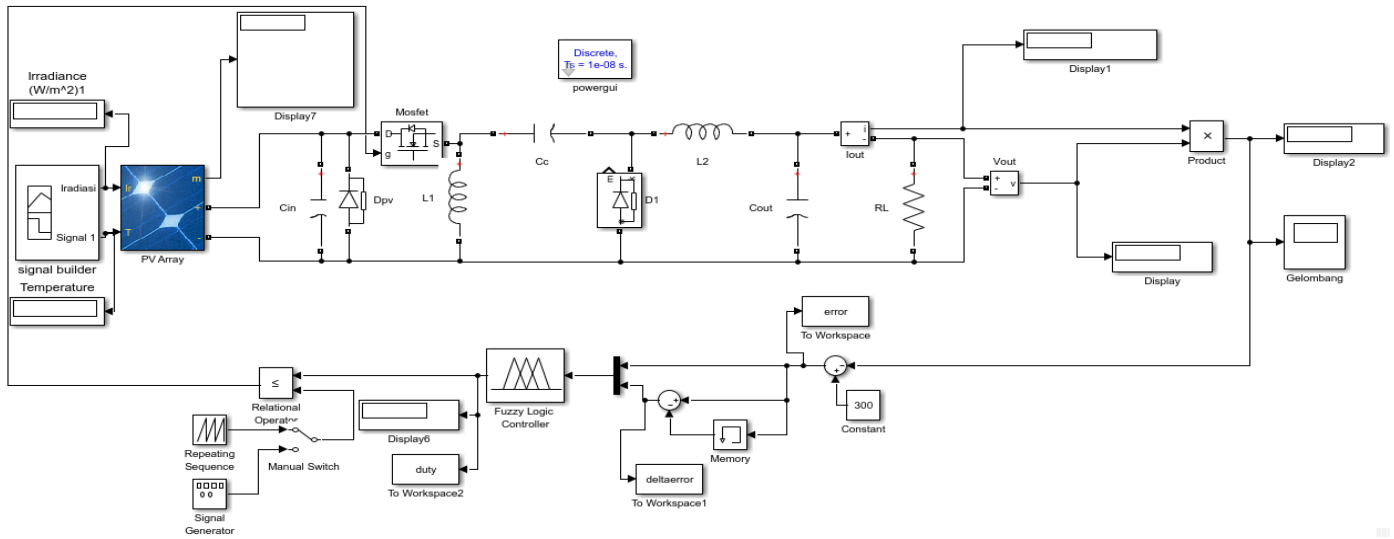

Figure 14. Simulation of Zeta Converter

A. The Result of Open Loop Zeta Converter Test

Before implementing the target to be used, the converter must be tested to determine the efficiency and reliability level of the converter. The following in Table 4 is data from the simulation test results of the zeta converter open loop.

Table 4. The Result of Zeta Converter Test

Duty (%)	Vout (V)	Iout (A)	Pin (W)	Pout (W)	Eff (%)
65.4	147.4	2.377	620	350.2	56.48
68.4	166.5	2.685	637.44	450	88.35
72.3	192.1	3.098	645.44	595	92.18
74.7	220	3.551	785	782	99.61
Average					84.15

In this zeta converter simulation, several duty cycle are used, 65.3%, 68.3%, 72.3% and 74.7%. From the zeta converter test, the average efficiency value of the zeta converter test is equal to 84.15% shown in Table 4. Then, after being simulated it can be seen the response of open loop zeta converter when duty cycle 74.7% like converter design. However, the output power of the converter simulated 782 W in Figure 15, while the design output power was 800 W.

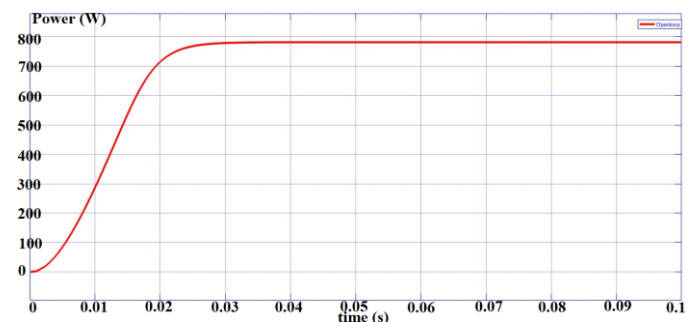

Figure 15. Response Open Loop System at Duty Cycle 74.7%

Figure 15 shows the response of the open loop system when the duty cycle is 74.7% appropriate with the output power from the converter at 782 W.

B. Simulation Result of FLC-ANFIS

In addition, from Table 5 it is the test data for close loop simulation using MATLAB software. The control used in the close loop system is FLC and ANFIS, are used to control the system in order to get a constant power with various setting points of 350 W, 450 W and 600 W. So that from Table 5 it is known that the average accuracy generated when using FLC is 98.08%, while the average accuracy generated when using ANFIS is 99.82%. So, it can be concluded that the average accuracy of ANFIS is higher than FLC. The test data of FLC and ANFIS used to compare the error generated in

each control. In the simulation that has been carried out, it uses a supply from a solar cell, so that to determine the performance of FLC and ANFIS it is necessary to provide interference by changing the irradiation at the running time of 0.025 s, 0.05 s and 0.075 s with an irradiation of 100 W/m², 400 W/m² and 600 W/m² as shown in Figure 16-18.

The test data requires a running time of 0.1 s to reach the desired setting point value. From Figure 16 we know that when setting point 350 W ANFIS reaches tracking time at 0.012 s and FLC only tracking time at 0.02 s, when setting point 450 W ANFIS reaches tracking time at 0.014 s and for FLC reaches tracking time at 0.02 s shown in Figure 17, and the last one is when setting point 600 W ANFIS reaches tracking time at 0.019 s and FLC has reached its tracking time first at 0.018 s with a value of 591.3 W shown in Figure 18.

Table 5. Simulation Result of FLC-ANFIS

Pin (W)	Setting Point (W)	Power (W)		Accuracy (%)	
		FLC	ANFIS	FLC	ANFIS
620	350	347	350	99.14	100
637.44	450	433.6	447.7	96.35	99.48
645.44	600	592.5	600	98.75	100
Average				98.08	99.82

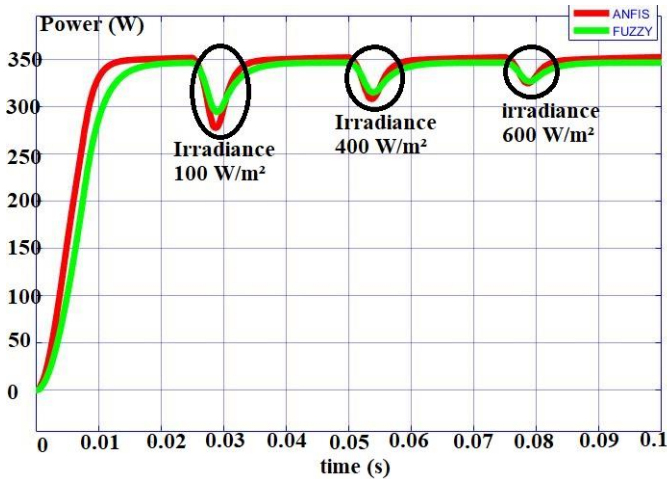

Figure 16. Response System of FLC-ANFIS at 350 W

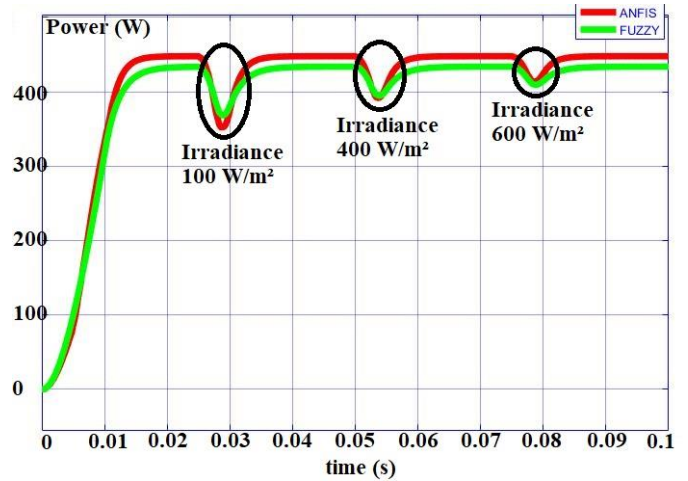

Figure 17. Response System of FLC-ANFIS at 450 W

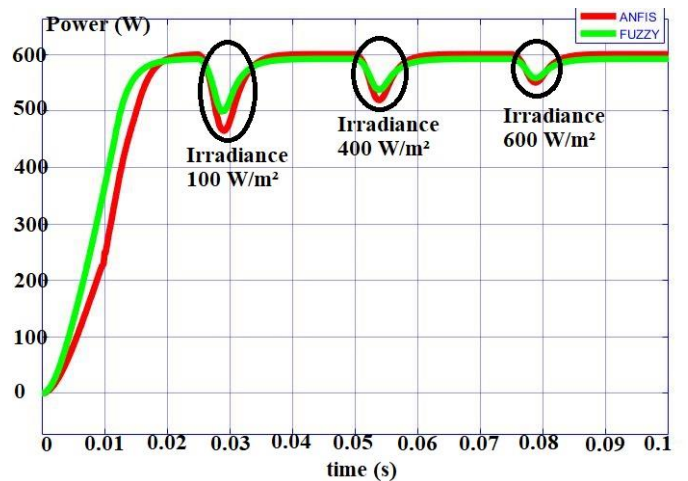

Figure 18. Response System of FLC-ANFIS at 600 W

IV. Conclusion

Comparison algorithm of FLC and ANFIS based zeta converter for constant power has been presented

1. The converter output power generated by this simulation can reach setting points.
2. The average accuracy produced by the ANFIS algorithm is 99.82% while FLC only produces an average accuracy of 98.08%.
3. ANFIS is faster to reach steady state than FLC.

References

- [1] Roslina, M. Zarlis, I. T. R. Yanto, and D. Hartama, "A framework of training ANFIS using Chicken Swarm Optimization for solving classification problems," in 2016 International Conference on Informatics and Computing (ICIC), Mataram, Indonesia, 2016, pp. 437–441, doi: 10.1109/IAC.2016.7905759.
- [2] De-Wang Chen and Jun-Ping Zhang, "Time series prediction based on ensemble ANFIS," in 2005 International Conference on Machine Learning and Cybernetics, Guangzhou, China, 2005, pp. 3552–3556 Vol. 6, doi: 10.1109/ICMLC.2005.1527557.
- [3] A. Y. Sonmez, S. Kale, R. C. Ozdemir, and A. E. Kadak, "An Adaptive Neuro-Fuzzy Inference System (ANFIS) to Predict of Cadmium (Cd) Concentrations in the Filyos River," *Turk. J. Fish. Aquat. Sci.*, Vol. 18, No. 12, 2018, doi: 10.4194/1303-2712-v18_12_01.
- [4] Hidayat, S. Pramonohadi, Sarjiya, and Suharyanto, "A comparative study of PID, ANFIS and hybrid PID-ANFIS controllers for speed control of Brushless DC Motor drive," in 2013 International Conference on Computer, Control, Informatics and Its Applications (IC3INA), Jakarta, Indonesia, Nov. 2013, pp. 117–122, doi: 10.1109/IC3INA.2013.6819159.
- [5] K. Amara *et al.*, "Improved Performance of a PV Solar Panel with Adaptive Neuro Fuzzy Inference System ANFIS based MPPT," in 2018 7th International Conference on Renewable Energy Research and Applications (ICRERA), Paris, Oct. 2018, pp. 1098–1101, doi: 10.1109/ICRERA.2018.8566818.
- [6] J. Falin, "Designing DC/DC converters based on ZETA topology," *Analog Applications Journal*. p. 8, 2010.
- [7] V. P. Dhote and G. P. Modak, "Analysis and study of Zeta converter fed by solar photovoltaic array," in 2017 Innovations in Power and Advanced Computing Technologies (i-PACT), Vellore, Apr. 2017, pp. 1–6, doi: 10.1109/IPACT.2017.8245041.
- [8] K. Manikandan, A. Sivabalan, R. Sundar, and P. Surya, "A Study Of Landsman, Sepic And Zeta Converter By Particle Swarm Optimization Technique," in 2020 6th International Conference on Advanced Computing and Communication Systems (ICACCS), Coimbatore, India, Mar. 2020, pp. 1035–1038, doi: 10.1109/ICACCS48705.2020.9074164.
- [9] Y. Bai and D. Wang, "Fundamentals of Fuzzy Logic Control — Fuzzy Sets, Fuzzy Rules and Defuzzifications," in *Advanced Fuzzy Logic Technologies in Industrial Applications*, Y. Bai, H. Zhuang, and D. Wang, Eds. London: Springer London, 2006, pp. 17–36.
- [10] A. Bastian, "Influencing the nonlinearity at the transition between fuzzy logic rules," in Proceedings of 1995 IEEE International Conference on Fuzzy Systems. The International Joint Conference of the Fourth IEEE International Conference on Fuzzy Systems and The Second International Fuzzy Engineering Symposium, Yokohama, Japan, 1995, vol. 3, pp. 1413–1418, doi: 10.1109/FUZZY.1995.409865.
- [11] L. Reznik, *Fuzzy controllers*. Oxford; Boston: Newnes, 1997.
- [12] F. Wahab, A. Sumardiono, A. R. Al Tahtawi, and A. F. A. Mulayari, "Desain dan Purwarupa Fuzzy Logic Control untuk Pengendalian Suhu Ruangan," (*Fuzzy Logic Control Design and Prototype for Room Control*), *J. Teknol. Rekayasa*, Vol. 2, No. 1, p. 1, Jul. 2017, doi: 10.31544/jtera.v2.i1.2017.1-8.
- [13] I. M. Ginarsa, A. Soeprijanto, and M. H. Purnomo, "Controlling chaos using ANFIS-based Composite Controller (ANFIS-CC) in power systems," in International Conference on Instrumentation, Communication, Information Technology, and Biomedical Engineering 2009, Bandung, Indonesia, Nov. 2009, pp. 1–5, doi: 10.1109/ICICI-BME.2009.5417262.
- [14] K. C. Raveendranathan, "A Class of ANFIS Based Channel Equalizers for Mobile Communication Systems," in 2009 First International Conference on Computational Intelligence, Communication Systems and Networks, Indore, India, Jul. 2009, pp. 486–491, doi: 10.1109/CICSYN.2009.40.
- [15] T. G. Ling, M. F. Rahmat, and A. R. Husain, "ANFIS modeling and Direct ANFIS Inverse control of an Electro-Hydraulic Actuator system," in 2013 IEEE 8th Conference on Industrial Electronics and Applications (ICIEA), Melbourne, VIC, Jun. 2013, pp. 370–375, doi: 10.1109/ICIEA.2013.6566397.