

University of Nebraska - Lincoln

DigitalCommons@University of Nebraska - Lincoln

Historical Materials from University of
Nebraska-Lincoln Extension

Extension

1980

It Pays to Test Your IRRIGATION PUMPING PLANT

George C. Morin

Deon D. Axthelm

LaVerne E. Stetson

Paul Fischbach

Dean Eisenhauer

See next page for additional authors

Follow this and additional works at: <https://digitalcommons.unl.edu/extensionhist>



Part of the [Agricultural Education Commons](#)

This Article is brought to you for free and open access by the Extension at DigitalCommons@University of Nebraska - Lincoln. It has been accepted for inclusion in Historical Materials from University of Nebraska-Lincoln Extension by an authorized administrator of DigitalCommons@University of Nebraska - Lincoln.

Authors

George C. Morin, Deon D. Axthelm, LaVerne E. Stetson, Paul Fischbach, Dean Eisenhauer, James R. Gilley, Wayne F. Kroutil, and Walter L. Trimmer

EC 80-713

It Pays to Test Your IRRIGATION PUMPING PLANT

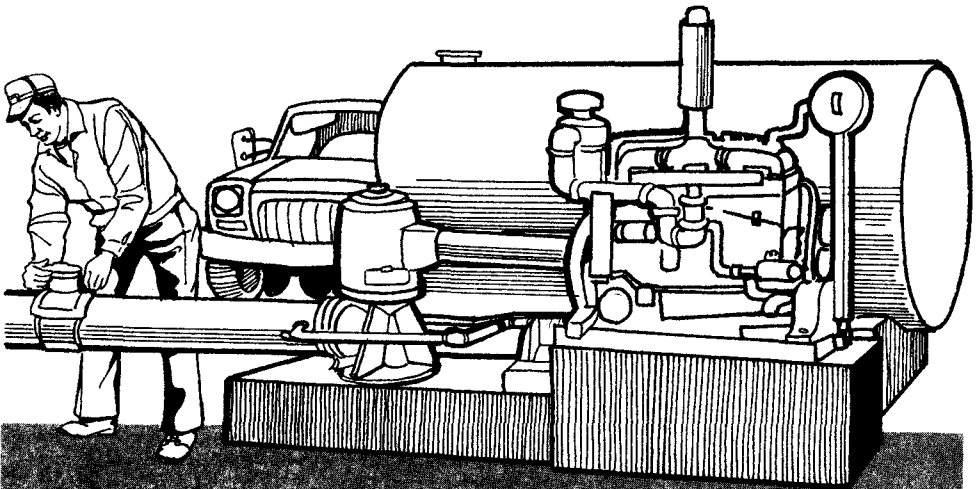

SPENDING MONEY ON AGRICULTURE, HOME ECONOMICS AND SUBJECTS RELATING THERETO,
CONDUCTED BY THE EXTENSION SERVICE, INSTITUTE OF AGRICULTURE AND NATURAL RESOURCES,
UNIVERSITY OF CALIFORNIA, GENERAL OPERATING BUDGET, LOS ANGELES COUNTY AND THE U.S. DEPARTMENT OF AGRICULTURE,
U.S. GOVERNMENT PRINTING OFFICE

It Pays to Test Your Irrigation Pumping Plant

George C. A. Morin, Deon D. Axthelm, LaVerne E. Stetson, Paul E. Fischbach
Dean E. Eisenhauer, James R. Gilley, Wayne F. Kroutil and Walter L. Trimmer ^{1/}

INTRODUCTION

A pumping plant performance test can determine the energy efficiency of an irrigation pumping plant and provide information on adjustments needed to improve energy efficiency. The performance of an irrigation pumping plant should be evaluated by trained personnel using accurate testing equipment. This service can be performed by consulting engineers, by many well drilling companies, and some Natural Resources Districts and Public Power Districts. See your County Extension Agent for more information concerning these services.

A pumping plant test should be performed regardless of the age of your system. Test all new systems so that you can be assured that your unit meets the contract specifications, which should be at least equal to the Nebraska Performance criteria for pumping plants (Table 1). The components must be carefully selected, installed, adjusted and operated to obtain these standard values.

For an existing pumping plant a test can determine:

1. If energy and money can be saved by adjusting, rebuilding, or replacing the existing pump, drive systems, or power unit.
2. If the well is being operated at too great a discharge rate for existing pump and well conditions.

BENEFITS OF A PUMPING PLANT TEST

The information obtained during the test includes water levels while pumping, discharge pressure, pump and engine speed, and energy use per hour. Conditions such as pumping sand or air are noted. These data are used to establish the performance rating of your pumping plant at its present discharge rate. Since you can also operate the unit at several other discharge rates, you may learn more about the following items.

Pumping Rate — From the test you can determine if the pumping rate is satisfactory or if it is possible to expand your irrigated acreage or if the acreage should be reduced. Knowledge of the pumping rate is also essential for calculating the amount of water applied and for irrigation water management.

^{1/}George C. A. Morin, District Extension Specialist (Irrigation); Deon D. Axthelm, Extension Water Resources Specialist; LaVerne E. Stetson, Assistant Professor Agricultural Engineering; Paul E. Fischbach, Extension Irrigationist; Dean E. Eisenhauer, District Extension Specialist (Irrigation); James R. Gilley, Associate Professor of Agricultural Engineering; Wayne F. Kroutil, District Extension Specialist (Irrigation); Walter L. Trimmer, District Extension Specialist (Irrigation).
Note—Morin, Axthelm, Stetson, and Fischbach wrote the original draft. Eisenhauer, Gilley, Kroutil and Trimmer reviewed the manuscript and suggested major changes which have been incorporated.

Water Levels — The test can help you determine at which discharge rate your pump should operate. If you are over-pumping your well and are pumping sand or air, the test can help you determine a practical pumping rate. In addition, the test can help you determine if lowering the pump bowls is required for more efficient pump operation.

Discharge Pressure — The test will determine the pump pressure for operating your distribution system. The person performing the test will be able to advise you if this is the design pressure for your distribution system.

Pump and Engine Speed — The test will determine if the pump and power unit are being operated at the most efficient point. These data can also be helpful in determining if the power unit is overloaded or if the power unit and pump are operating at the wrong speeds. The values can tell you if a belt drive system has excessive slippage.

Energy Use — Knowledge of your energy use for the work being accomplished will allow you to evaluate your irrigation costs. This is the primary reason for the performance test.

EVALUATION OF YOUR PUMPING PLANT

Accurate test measurements are needed to evaluate the performance of a pumping plant. The data used are:

1. The measurements of lift (water level with pump operating), discharge pressure, and discharge rate used to determine the rate work is being done by the pumping plant.

2. The rate work is done by the pumping plant divided by the energy use rate of the power unit to establish the level of performance of the pumping plant.

The measured performance is then evaluated against the Nebraska Performance criteria for pumping plants (Table 1) to determine how it compares.

If the components are carefully selected and if larger power units and pumps with more than one pump bowl are used, it is possible to obtain a pumping plant which will exceed the criteria.

A small pumping plant or reuse system may be less efficient than the criteria. Correction factors of the water horse power-hours (whp.h) per unit of energy for large and small pumping plants are included in Table 2. Since not all sizes of electric motors have the same efficiency correction factors of the whp.h per kilowatt-hour (kwh) of electricity are included in Table 3.

The following examples illustrate how data are used to obtain the pumping plant performance rating.

Example 1.^{2/}

Field test data — Gated Pipe

Power unit	30 hp electric
Pumping rate	700 gallons per minute (gpm)
Number of bowls	2
Bowl diameter	8 inches (in)

^{2/} For an example using metric units see Appendix

Lift75 75 feet (ft)
 Pressure10 pounds per in² (psi)
 Energy use rate25 kilowatt-hours per hour
 (kW .h/h)

1. *Determine water horsepower (whp) (rate energy is added to water)*

$$\text{whp} = \frac{\text{pumping rate (gpm)} \times \text{total head (ft)}}{3,960}$$

$$\text{Total head (ft)} = \text{Lift (ft)} + (2.31 \times \text{Pressure [psi]})$$

$$\text{Total head (ft)} = 75 + (2.31 \times 10) = 98.1 \text{ ft}$$

$$\text{whp} = \frac{700 \text{ gpm} \times 98.1 \text{ ft}}{3,960}$$

$$= 17.3 \text{ hp}$$

2. *Determine pumping plant performance (water horsepower divided by rate of energy use)*

$$\text{whp divided by kW.h/h} = \frac{17.3 \text{ whp}}{25 \text{ kW.h/h}}$$

$$= 0.692 \text{ whp.h/kw.h}$$

3. *Determine the performance rating*

a. Obtain Nebraska Performance criteria from Table 1. whp.h/kW.h = 0.885

b. Multiply by appropriate pump (Table 2) and electric motor (Table 3) correction factors to obtain adjusted Nebraska Performance criteria.

$$.885 \text{ whp.h/kW.h} \times 0.988 \times 1.00 = 0.874 \text{ whp.h/kW.h}$$

c. Performance Rating = measured whp.h/kW.h

$$\frac{\text{measured whp.h/kW.h}}{\text{adjusted Nebraska Performance criteria}}$$

$$\text{Performance Rating} = \frac{0.692}{0.874}$$

$$= 0.79$$

4. *Determine excess energy use per hour of operation*

$$\text{Excess energy use} = (1.00 - \text{Rating}) \times \text{Measured Fuel Use}$$

$$= (1.00 - 0.79) \times 25 \frac{\text{kW.h}}{\text{h}} = 5.25 \frac{\text{kW.h}}{\text{h}}$$

Example 2.

Field test data — Center pivot (or other sprinkler system)

Power unit125 hp diesel

Pumping rate800 gpm

Number of bowls5

Bowl diameter12 in

Lift100 ft

Pressure65 psi

Energy use rate4.9 gallons per hour (gal/h)

1. *Determine water horsepower*
 Total head (ft) = 100 + (2.31 x 65) = 250 ft

$$\text{whp} = \frac{800 \text{ gpm} \times 250 \text{ ft}}{3,960}$$

$$= 50.5 \text{ hp}$$
2. *Determine pumping plant performance*

$$= \frac{50.50 \text{ whp}}{4.9 \text{ gal/h}}$$

$$= 10.3 \text{ whp.h/gal}$$
3. *Determine the performance rating*
 - a. Performance criteria (Table 1) = 10.9 whp.h/gal
 Multiply by appropriate pump correction factor (Table 2) to obtain adjusted Nebraska Performance Criteria.
 Note: Diesel - No electric motor correction factor required.
 - b. Table 1 x Table 2

$$10.9 \text{ whp.h/gal} \times 1.07 = 11.7 \text{ whp.h/gal}$$
 - c. Rating = $\frac{10.3}{11.7}$

$$= 0.88$$
4. *Determine excess energy use per hour of operation*
 Excess energy use/hr

$$(1.00 - 0.88) \times 4.9$$

$$= 0.59 \text{ gallons diesel/h}$$

CAUSES OF BELOW STANDARD PERFORMANCE

Any of the three major components of the pumping plant; pump, drive, or power unit, can cause poor performance. In addition, mismatching of components, poor selection of components, or changing water levels may cause reduced efficiency.

The Pump — A pump's impeller(s) is selected to deliver efficiently a particular rate of water to a certain elevation (including pressure head) and at a specific rotational speed. It is possible to select impellers which are quite efficient for a wide range of conditions or to choose an impeller which is even more efficient for only one specific set of conditions. However, in some cases this more specifically selected impeller will be inefficient when conditions are altered. The addition of pressurized discharge distribution systems or the redesign from a high to a low pressure discharge distribution system can cause pump efficiency to decrease. Have technically qualified individuals make the initial impeller selection and help determine if your impellers are matched to existing operation conditions.

Pump impellers can be out of adjustment for pumps with semi-enclosed impellers and for some enclosed impellers. Impellers out of adjustment will

require greater than normal pump and engine speeds to deliver a specified amount of water. Trained individuals and qualified pump manufacturers' representatives are able to adjust impeller clearances to obtain optimum pump capacity and head. EC 74-760 How to Adjust Vertical Turbine Pumps for Maximum Efficiency^{3/} provides information for adjusting an impeller. Worn or corroded impellers cannot be brought back to original capacity, head, or efficiency by adjustment.

If the pump is being operated above or below its design speed this may result in inefficient operation. The use of an accurate tachometer will enable the operation of the pump at the design speed.

For centrifugal pumps, warping of the pump case or bending of the pump shaft may cause increased friction of the rotating part. The wear ring can allow internal circulation of water in some instances. Improperly designed suction and discharge assemblies can cause reduced efficiency.

The Power Unit — A power unit can require more fuel than normal if it is not loaded properly, if it lacks proper servicing, if it is not "tuned" properly, or if it contains worn components.

Internal combustion engines work most efficiently when operated between 75% and 100% of their continuous duty rated horsepower and when they are operated at the correct speed. Technically qualified individuals can advise you on the proper selection of drive ratios for new pumping plants so that the engine will be correctly loaded and operate at the correct speed. They can also advise you if an existing system has the correct drive ratio.

Proper maintenance of the power unit is also necessary for efficient operation of a pumping plant. A power unit should be serviced at regular intervals and should be winterized for the off season. In addition, an engine should receive a tune-up as required. For spark ignition systems the tune-up should consist of ignition timing, spark plug and point replacement, and a cleaning, adjustment of the carburetor. For diesels the entire fuel injection system may require servicing. During the tune-up the air cleaner should be serviced. A tune-up can result in a substantial reduction in fuel consumption.

Excessively worn engine valves and piston components may allow a compression loss resulting in poor fuel economy. Compression tests can be run on the engine to determine which components require replacement or need to be rebuilt. A worn engine will significantly affect the efficiency of a pumping plant.

The efficiency of electric motors seldom changes during use for a given load. If the motor is underloaded, it will operate less efficiently than it will under proper load. If the motor is overloaded according to the service factor, efficiency may not be reduced, however, motor life will be shortened.

The Drive — The drive ratio may not be correctly matched to pump engine speeds. This is a cause of inefficient operation of the pump, the engine, or both units. Drive misalignment will increase friction and reduce driveline life.

Technically qualified individuals with the manufacturers' pump and engine curves can select the correct drive ratio.

^{3/} Available through your local County Extension Office.

Table 1. Nebraska performance criteria for pumping plants.

Energy source	hp.h ^{a/} /Unit of energy	whp.h ^{b/} /Unit of energy ^{c/}	Energy units
Diesel	14.6 ^{d/}	10.9	gallon
Gasoline	11.5 ^{d/}	8.66	gallon
Propane	9.20 ^{d/}	6.89	gallon
Natural Gas	82.2 ^{e/}	61.7	1000 ft ³
Electricity	1.18 ^{f/}	0.885 ^{g/}	kW.h

^{a/} hp.h (horsepower-hours) is the work being accomplished by the power unit with drive losses considered.

^{b/} whp.h (water horsepower-hours) is the work being accomplished by the pumping plant at the Nebraska Performance Criteria.

^{c/} Based on 75% pump efficiency, i.e. the average of representative manufacturers' laboratory data for 1-bowl pumps adjusted for column and power shaft losses for 8-inch column pipe at a 100-foot bowl setting.

^{d/} Taken from Test D of Nebraska Tractor Test Reports. Drive losses are accounted for in the data.

^{e/} Manufacturers' data corrected for 5% gear head drive loss. Assumes natural gas energy content of 925 BTU per cubic foot. At 1000 BTU per cubic foot energy content use a Performance Criteria of 88.9 hp.h/1000 ft³ for natural gas.

^{f/} Assumes 88% electric motor efficiency, i.e. 10 to 40 nameplate horsepower.

^{g/} Direct drive, assumes no drive loss.

Table 2. Pump correction factor.

Turbine Pumps

No. of Bowls	Pump Correction Factor ^{a/}	
	6'' & 8'' Bowls	10'' & Larger Bowls
3 or more	1.02	1.07
2	0.988	1.06
1	0.948	1.02

Centrifugal Pumps

Power Unit Size	Pump Correction Factor, ^{b/}
less than 10 hp	0.929
greater than 10 hp	1.02

^{a/} Averages of representative pump manufacturers' data.

^{b/} Assumes suction lift does not exceed manufacturer's recommendations.

Table 3. Electric motor correction factor.

Electric motor size	Electric motor correction factor ^{a/}
h p	
2.0 - 7.5	0.932
10 - 40	1.00
50 - 75	1.04
100 - 400	1.05

^{a/} Averages of representative electric motor manufacturers' data.

APPENDIX - NECESSARY TABLES, EQUATIONS AND AN EXAMPLE CALCULATION USING METRIC UNITS

Table 1A. Nebraska performance criteria for pumping plants.

Fuel	kW.h ^{a/} /Unit of energy	wkW.h ^{b/} /Unit of energy ^{c/}	Energy units
Diesel	2.88 ^{d/}	2.16	liters
Gasoline	2.28 ^{d/}	1.71	liters
Propane	2.07 ^{d/}	1.36	liters
Natural Gas	2.17 ^{e/}	1.63	m ³
Electricity	0.880 ^{f/}	0.660 ^{g/}	kW.h

^{a/} kW.h (kilowatt-hours) is the work being accomplished by the power unit with drive losses considered.

^{b/} wkW.h (water kilowatt-hours) is the work being accomplished by the pumping plant at the Nebraska Performance Criteria.

^{c/} Based on 75% pump efficiency, i.e. the average of representative manufacturers' laboratory data for 1-bowl pumps adjusted for column and power shaft losses for 20.3-centimeter column pipe at a 30.5-meter bowl setting.

^{d/} Taken from Test D of Nebraska Tractor Test Reports. Drive losses are accounted for in the data.

^{e/} Manufacturers' data corrected for 5 percent gear head drive loss. Assumes energy content of 34.5 (megajoules) MJ per cubic meter. At 37.3 MJ per cubic meter use Nebraska Standard of 2.35 kW.h/m³ of natural gas.

^{f/} Assumes 88 percent electric motor efficiency, i.e. 7.46 to 29.8 kW nameplate rating.

^{g/} Direct connection, assumes no drive loss.

Table 2A. Pump correction factor.

Turbine Pumps		Pump Correction Factor ^{a/}	
		15.2 cm & 20.3 cm bowls	25.4 cm & Larger Bowls
No. of Bowls			
3 or more		1.02	1.07
2		0.988	1.06
1		0.948	1.02

Centrifugal Pumps		Pump Correction Factor ^{ab/}
Power Unit Size		
less than 7.46 kW		0.929
greater than 7.46 kW		1.02

^{a/} Averages of representative pump manufacturers' data.

^{b/} Assumes suction lift does not exceed manufacturer's recommendations.

Table 3A. Electric motor correction factor.

Electric motor size	Electric motor correction factor ^{a/}
kW	
1.49 - 3.68	0.932
7.46 - 29.8	1.00
37.3 - 55.6	1.04
74.6 - 298	1.05

^{a/} Averages of representative electric motor manufacturers' data.

Example: (same as Example 1 English Units)

Field test data — Gated Pipe

Power unit	22.4	kW Rating
Pumping rate	44.2	liters/second (1/s)
Number of bowls	2	
Bowl diameter	20.3	centimeters (cm)
Lift	22.9	meters (m)
Pressure	68.9	kilopascals (kPa)
Energy use rate	25	kilowatt-hours per hour (kW.h/h)

1. *Determine water kilowatts (wkW)* (rate energy is added to the water)

$$\text{wkW} = \frac{Q(1/s) \times \text{Total Head (m)}^{1/2}}{102.4}$$

$$\text{Total head (m)} = \text{Lift (m)} + (.102 \times \text{pressure [kPa]})$$

$$\text{Total head (m)} = 22.9 + (.102 \times 68.9) = 29.9$$

$$\text{wkW} = \frac{44.2 \times 29.9}{102.4}$$

$$= 12.9 \text{ kW}$$

2. *Determine pumping plant performance* (water kilowatts divided by rate of energy use)

$$\text{wkW} \div \text{kW.h/h} = \frac{12.9 \text{ wkW}}{25 \text{ kW.h}}$$

$$= 0.516 \text{ wkW.h/kW.h}$$

3. *Determine the performance rating*

(a) Obtain Nebraska Performance criteria from Table 1A.
 $\text{wkW.h/kW.h} = 0.660$

(b) Multiply by appropriate pump (Table 2A) and electric motor (Table 3A) Correction factors

$$0.660 \text{ wkW.h/kW.h} \times 0.988 \times 1.00 = 0.652 \text{ wkW.h/kW.h}$$

(c) Rating = $\frac{\text{measured wkW.h/kW.h}}{\text{adjusted Nebraska Performance Criteria}}$

$$= \frac{0.516}{0.652}$$

$$= .79$$

4. *Determine excess energy use per hours of operation*

$$\text{Excess energy use} = (1.00 - \text{Rating}) \times \text{measured fuel use}$$

$$(1.00 - .79) \times 25 \frac{\text{kW.h}}{\text{h}} = 5.25 \frac{\text{kW.h}}{\text{h}}$$

The Cooperative Extension Service provides information and educational programs to all people without regard to race, color or national origin.