

Purdue University

**Purdue e-Pubs**

---

International Refrigeration and Air Conditioning  
Conference

School of Mechanical Engineering

---

2021

## **Two-Stage Compression With Vapor Injection: A Study On A Disregarded Solution In CO2 Booster Applications For Supermarket Refrigeration**

Javier Ignacio Vega  
*Université de Liège, Belgium, jivega@uliege.be*

Camila Dávila

Vincent Lemort  
*Université de Liège, Belgium*

Follow this and additional works at: <https://docs.lib.purdue.edu/iracc>

---

Vega, Javier Ignacio; Dávila, Camila; and Lemort, Vincent, "Two-Stage Compression With Vapor Injection: A Study On A Disregarded Solution In CO2 Booster Applications For Supermarket Refrigeration" (2021). *International Refrigeration and Air Conditioning Conference*. Paper 2185.  
<https://docs.lib.purdue.edu/iracc/2185>

This document has been made available through Purdue e-Pubs, a service of the Purdue University Libraries. Please contact [epubs@purdue.edu](mailto:epubs@purdue.edu) for additional information. Complete proceedings may be acquired in print and on CD-ROM directly from the Ray W. Herrick Laboratories at <https://engineering.purdue.edu/Herrick/Events/orderlit.html>

# Two-Stage Compression With Vapor Injection: A Study On A Disregarded Solution In CO<sub>2</sub> Booster Applications For Supermarket Refrigeration

Javier VEGA<sup>1\*</sup>, Camila DÁVILA<sup>1</sup> Vincent LEMORT<sup>1</sup>

<sup>1</sup> University of Liège , Energy Systems Research Unit  
Liège, Wallonia, Belgium

\* Corresponding Author

Contact Information (+32493085263, jivega@uliege.be)

## ABSTRACT

CO<sub>2</sub> refrigeration has been largely implemented, especially in supermarket applications. Nonetheless, one solution that has been often disregarded in these applications has been the inclusion of Two-Stage compression cycles including vapour injection. Available literature has not yet compared these solutions with Booster applications. Thus, this paper presents the modelling of two solutions of Two-Stage vapour injection cycles in a Booster configuration application: Flash Tank vapour injection (FTVI) and Sub-cooled Vapour injection (SCVI). The adopted methodology is more focused on the thermodynamic cycle rather than detailed components modelling. An analysis of the optimal displacement ratio between compression stages has been conducted, exploring the influence of this parameter on the optimum transcritical high pressure. It has been found that optimal high pressure does not vary considerably when changing displacement ratio and that, for different operating points, FTVI optimum ratio lays around 0.95, while for SCVI, sits around 0.85. The FTVI and SCVI cycles performances are compared with models of Basic Booster Cycle, Parallel Compression, Gas Ejector assisted Parallel compression and Liquid Ejector assisted Parallel Compression architectures. COP comparison for different ambient temperatures is performed, with each system working close to its optimum. The most competitive Two-Stage solution is the SCVI cycle, performing similarly to the the Gas Ejector cycle at high temperatures conditions, reaching a 21.5% against 23% COP increase, respectively, over the basic Booster at 44 °C ambient temperature. A sensitivity analysis is carried for different hypotheses. It is found that assuming higher compressor efficiency in all systems increases the comparative advantage of the Two-Stage cycles. In an ideal scenario, SCOP is computed for the climates of Helsinki, Strasbourg and Athens. Results suggest that the ejector cycles still are the best overall performing. However, this scenario assumes that Parallel Compression is always active, which is not often possible in sub-critical operation. A second "realistic" scenario is defined, giving FTVI and SCVI cycles energy savings with respect to the basic Booster an advantage of 4.08% and 5.35% against 3.41% of the Gas Ejector system.

## 1. INTRODUCTION

The F-gas regulation is still shaking the HVAC&R industry, leading researchers and innovative companies to find cleaner and more efficient technologies. In the refrigeration sector, it has revived the interest in applying propane (R290), ammonia (R717) and carbon dioxide (R744), which this paper focuses on, as the refrigerant working fluid. Specifically in the food retail sector, CO<sub>2</sub> has been successfully established in countries that have politically enforced technological transition towards cleaner solutions. For example, it has been reported that, as in 2019, in Europe, CO<sub>2</sub>-based supermarkets account for 14%, and that at least 3530 plants are operating in Japan (Skačanová and Battesti, 2019).

Nonetheless, a particularity of the CO<sub>2</sub> is that it works in high-pressure transcritical conditions when ambient temperature is high, leading to high performance losses in traditional refrigeration architectures. In addition, supermarket refrigeration requires a Low Temperature circuit which, at first, added another challenge to R744 application. What has allowed this working refrigerant to be competitive and commonly adopted is the very active research surrounding it to improve its performance in warm climates. Many first attempts to efficiently apply R744 in supermarket application have converged to an architecture denominated "Booster", that can provide Medium and Low temperature cooling (MT and LT). Today, recent and common adopted innovative technology has come in the form of including Parallel Compression (PC), Multi-Ejectors (ME) and different Sub-cooling Methods in the system architecture. Some authors have classified these in three development generations: 1<sup>st</sup> generation, Booster Layout; 2<sup>nd</sup> generation, PC; and 3<sup>rd</sup>

generation, ME (Gullo et al., 2018).

In this context, this manuscript's authors have noticed that in recent open literature there has been a relative disregard towards possible Vapour Injection (VI) solutions for supermarket refrigeration. Mainstream attention is leaning primarily towards ejector solutions, such as stated by Gullo et al. (2018). This, taking into consideration that Two-Stage compression with VI has already been studied in open literature to a certain extent. CO<sub>2</sub> VI Heat-Pump (HP) applications have been studied to some degree (Baek et al., 2014a) (Baek et al., 2014b) (Pitarch et al., 2016). Studies covering the food-retail cooling-demand temperature range have also been developed Hwang et al. (2004) (Cavallini et al., 2005) (Cecchinato et al., 2009). Within these research work, some interesting coupling of this architecture has been done with mechanical sub-cooling, such as (Liu et al., 2019), expanders, such as (Liu et al., 2017), and ejectors, such as (Xing et al., 2014). On the other side, Two-Stage Compressors adapted for VI have already been developed and commercialized by industrial manufacturers (Mizuno et al., 2017) (Tashibana, 2015).

The motivation of this paper is that none of the R744 TwoStage VI architecture public literature found compares its performance with existing R744 refrigeration technology of its 1<sup>st</sup>, 2<sup>nd</sup> and 3<sup>rd</sup> generations. Thus, the aim of this work is to theoretically compare these solutions through modelling and simulation. First, the studied system architectures are presented. Secondly, modelling and overall methodology are described, putting emphasis in the fact that systems are simulated as close to optimal operation as possible. Finally, performances are compared and used for Seasonal COP (SCOP) analysis in three different climates.

## 2. MODELLING AND METHODOLOGY

### 2.1 General scope

The study is focused in the thermodynamic analysis and performance comparison of six R744 systems. The Booster Layout, as shown in Figure 1, is set as the baseline performance for comparison. A 2<sup>nd</sup> generation PC architecture is defined as in Figure 2, and 3<sup>rd</sup> generation ME systems are also studied in the forms of a Gas-Ejector-exclusive architecture (GEPC system) and Liquid-Ejector-exclusive layout (LEPC system), presented in Figure 3 and 4 respectively. These, are put in contrast with two Two-Stage VI systems. One layout corresponds to a Flash Tank Vapour Injection (FTVI), the other, to a Sub-Cooler Vapour Injection (SCVI); as shown in Figure 5 and 6. With the purpose of studying the systems at their theoretical maximum performance, it is assumed that the PC system and both ME systems have their By-Pass valves closed.

Every system is modelled using the Python programming language. As this study intends to make a first approach into these systems comparison, models are more focused in the thermodynamic cycles rather than detailed components modelling. Compressors' and ejectors' performances are set constant, although sensitivity analyses for these are performed to understand if conclusions may be affected by these hypotheses. Evaporating temperatures are set as the same constant value, except for the LEPC system, where a temperature lift is established and varied by means of a sensitivity analysis. Constant system variables and base-line parameters imposed are described in Table 1. Ejector performance are defined as described by (Elbel and Hrnjak, 2008): entrainment ratio, defined in Equation 1, is the ratio of the suction to the motive mass flow, while the efficiency defined in Equation 2 is the ratio of the expansion work recovered for compression to the maximum possible expansion work rate recovery. As for the gas ejector performance, results are also presented using performance profiles derived from Danfoss CoolSelector2. Performance data for  $P_{FT} = 35$  bar are presented in Figure 7.

$$\varphi_{ej} = \frac{\dot{m}_{suc}}{\dot{m}_{mot}} \quad (1)$$

$$\eta_{ej} = \varphi_{ej} * \frac{\dot{W}_{rec}}{\dot{W}_{pot}} \quad (2)$$

**Table 1:** Base-line systems' variables and parameters

$T_{ev,MT}$	$SH_{MT}$	$T_{ev,MT,liqEj}$	$T_{ev,LT}$	$SH_{LT}$	$SC_{GC}^a$	$\epsilon_{s,HS}$ , $\epsilon_{s,PC}$	$\epsilon_{s,LS}$	$\eta_{ej,gas}$	$\eta_{ej,liq}$
-10 °C	10 K	-7 °C	-35 °C	8 K	3 K	0.6	0.7	0.2	0.02

<sup>a</sup> Sub-cooling of the gas cooler when acting as a condenser

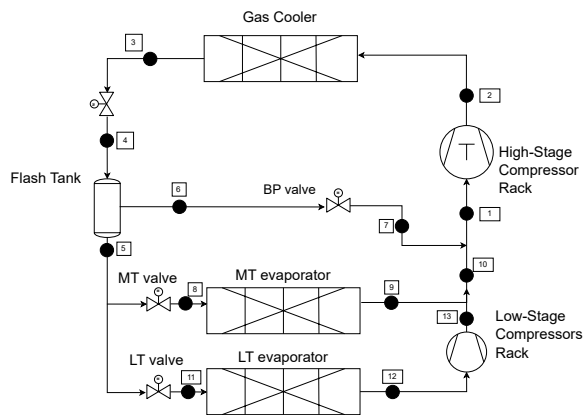

Figure 1: Booster Layout (1<sup>st</sup> gen.)

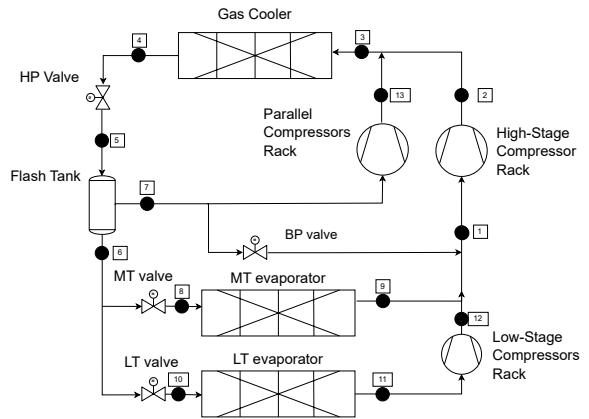

Figure 2: PC Layout (2<sup>nd</sup> gen.)

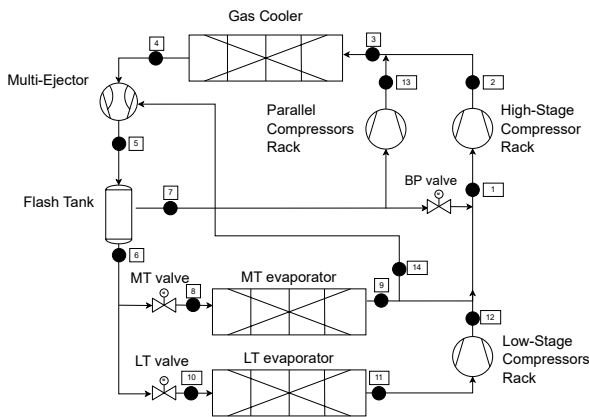

Figure 3: GEPC Layout (3<sup>rd</sup> gen.)

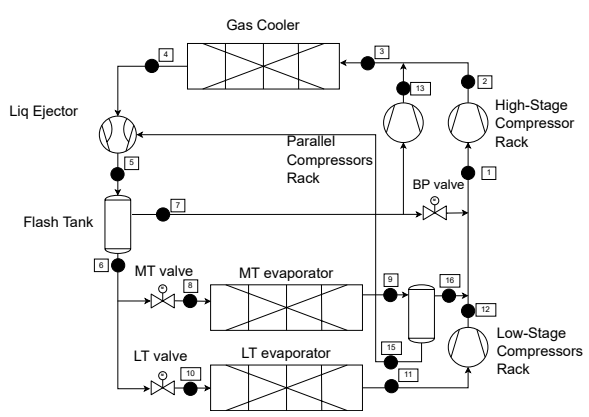

Figure 4: LEPC Layout (3<sup>rd</sup> gen.)

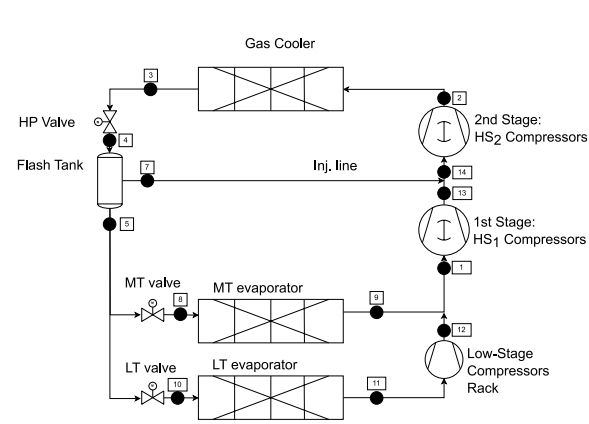

Figure 5: FTVI Layout

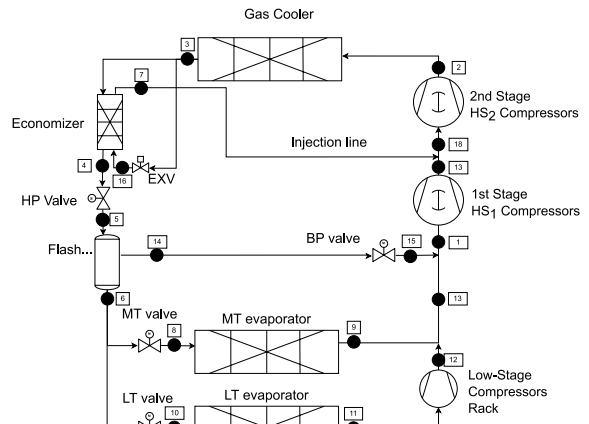
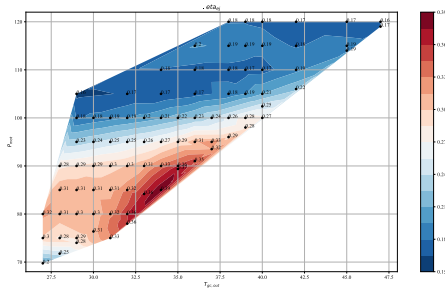
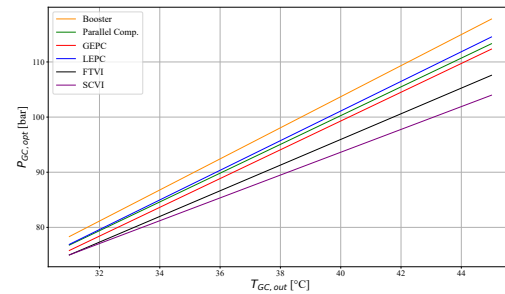

Figure 6: SCVI Layout



**Figure 7:** Ejector Efficiency Envelope for  $P_{FT} = 35$  bar



**Figure 8:** Optimal Pressure linear functions resulted by COP loss minimization

## 2.2 Optimal Displacement ratio and Optimal Pressure

In VI systems, an optimal injection pressure can be determined. Usually, this optimal is near the geometrical mean between suction and discharge pressures (Threlkeld, 1962); although, it has been reported that in R744 applications the optimum seats 15% to 37% higher (Baek et al., 2002) (Elbel and Hrnjak, 2020). If injection pressure can not be totally controlled, injection performance is closely related to the displacement ratio ( $V_r$ ), defined in Equation (3). This is the case for the proposed FTVI system, where the injection pressure corresponds to the Flash Tank (FT) pressure, as it adapts to adjust itself to match the amount of gas to what the compressor can take with the associated fluid densities. On the other hand, in the proposed SCVI system, a constant injection superheat control is assumed, resulting in a similar effect regarding the economizer/ injection pressure. The swept volumes of the 1<sup>st</sup> and 2<sup>nd</sup> stages of compression will establish boundaries to the mass flows ratios in the system and, thus, the equilibrium pressure in the FT or in the Economizer-Subcooler. A  $V_r$  quasi-optimization is pursued by varying the displacement ratio. It is considered that both  $HS,1$  and  $HS,2$  compressors are the same machine and, thus, work at the same rotating speed. On the other hand, each system's  $P_{GC,opt}$  is calculated. A linear correlation is established following the minimal COP loss method (Yang et al., 2015).

$$V_r = \frac{V_{displ,HS,2}}{V_{displ,HS,1}} \quad (3)$$

## 2.3 Seasonal Coefficient of Performance Calculation

SCOP is calculated using three sets of typical meteorological year data. Helsinki, Strasbourg and Athens are selected for the study. Using the optimizations, COP calculations for each system and sensitivity analyses, calculations are done by defining cooling load profiles and coupling this demand with the meteorological data of a typical year, using the bin hours method. Supermarket Open Hours are defined between 8 a.m and 7 p.m, excluding days 7, 14, 21, 28 and 31 of each month. The rest of the bin hours are considered as Closed Hours. The MT cooling profile selected is established taking inspiration from the in-field survey of a R744 supermarket system done by Dugaria et al. (2019). MT cooling demand is set to its minimum for supermarket Closed Hours, as described in Equation 5. On its side, LT demand is set to an invariable 24 kW for any condition. The load fraction between the MT and LT peak demands is within the range of 2-5 indicated by (Sharma et al., 2014).

$$\dot{Q}_{MT} = \begin{cases} 72 & kW, \quad \text{if } T_{amb} > 6^\circ, \\ 5 \cdot T_{amb} + 40 & kW, \quad \text{if } 0^\circ \leq T_{amb} \leq 6^\circ, \\ 40 & kW, \quad \text{if } T_{amb} < 0^\circ \text{ or Closed Hours} \end{cases} \quad (4)$$

## 3. RESULTS

### 3.1 Pressure optimization comparison

A linear pressure optimization function is calculated for each system in transcritical operation, the resulting functions are presented in Figure 8. Six different  $T_{GC,out}$  are used at each system to obtain its optimization function, at maximum cooling demand,  $P_{FT} = 35$  [bar] and nominal parameters from Table 1. Both VI systems have the lowest gas cooler optimal pressures of all systems, the SCVI Layout having the flattest  $P_{GC,opt}$  function and registering up to 12 bar of

difference with the Booster Layout at  $T_{GC,out} = 46^\circ\text{C}$ . An analysis of different system parameters on optimal pressure

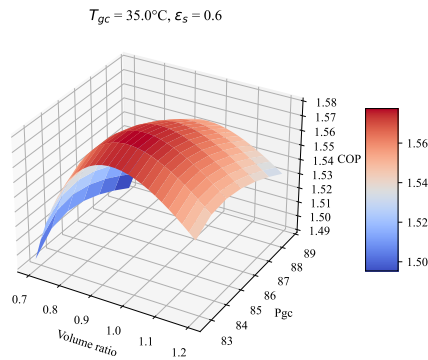

**Figure 9:** FTVI system COP optimization by  $P_{GC}$  and  $V_r$  parametric analysis

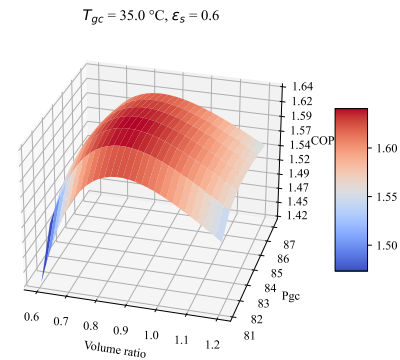

**Figure 10:** SCVI system  $V_r$  optimization in the subcritical region

has been performed. For the studied range in the sensitivity analysis, results suggest that compressor and ejectors efficiency don't have a considerable effect on the  $P_{GC,opt}$  functions. On the contrary, FT pressure does show an expected influence on optimal pressure in the PC Layout and the GEPC Layout. If FT pressure is increased, pressure ratio across the PC rack is diminished, allowing to further increase  $P_{GC}$  to gain cooling capacity without too much compression work penalty. This occurs until the trade-off is no longer beneficial, leading to a different  $P_{GC,opt}$ . Nonetheless, the  $P_{GC,opt}$  for different  $P_{FT}$  only differs considerably at very high  $T_{GC,out}$ .

### 3.2 Displacement ratio optimization comparison

$V_r$  optimization results have shown somewhat different results for the FTVI and the SCVI systems. Adding the combined effect of fixing evaporating temperatures with the aforementioned constraints of  $P_{inj}$ , in both VI systems,  $V_{r,opt}$  becomes a function of  $T_{GC,out}$ . Thus, in transcritical operation,  $V_{r,opt}$  tends to slightly increase with higher  $T_{GC,out}$ . In the FTVI Layout,  $V_{r,opt}$  revolves around 0.95, while SCVI shows a lower value of about 0.85. displacement ratio also affects the location of  $P_{GC,opt}$ , as shown in Figure 9 and Figure 10. Nonetheless, excluding the case of a  $P_{GC,opt}$  heavy underestimation, systems' performance are more sensitive to  $V_r$  rather than to the gas cooler pressure. This means that, after designing the system with a reasonable fixed  $V_r$ , neglectable COP loss occurs by applying a single  $P_{GC,opt}$  adapted linear function determined with the selected displacement ratio. The surfaces in Figures 9 and 10 also show that the limit line where COP drops rapidly with  $P_{GC,opt}$  is parallel to the  $V_r$  axis. In consequence, the aforementioned methodology doesn't risk a dramatic COP loss by underestimation of the gas cooler pressure.

Contrary to the transcritical region, in the sub critical mode,  $V_{r,opt}$  increases with lower  $T_{GC,out}$ , as shown in Figure 11 and Figure 12. Thus, results show that the minimum optimal ratio occurs around the critical point.

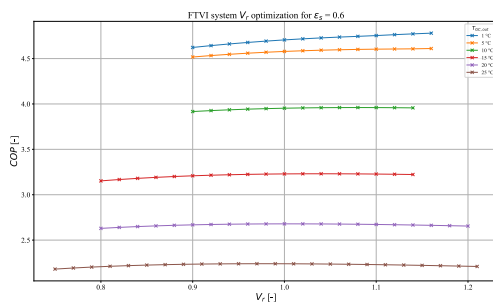

**Figure 11:** FTVI system  $V_r$  optimization in the subcritical region

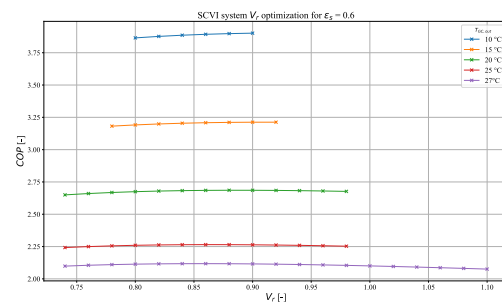

**Figure 12:** SCVI system  $V_r$  optimization in the subcritical region

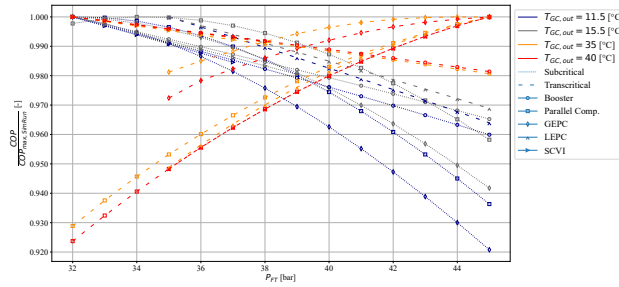

Figure 13: Systems COP variation with  $P_{FT}$

### 3.3 Flash Tank Pressure Optimization

To compare the studied system models at their best possible operating conditions, Flash Tank Pressure,  $P_{FT}$ , influence on COP and its impact on  $P_{GC,opt}$  is also studied.  $P_{FT}$  is analysed in the range of 32 to 45 bar. Overall results show that if the system model does not have PCs, the optimal  $P_{FT}$  is the minimum in the studied range. On the other hand, system models that include PC do present a variable optimum mainly dependent on  $T_{GC,out}$ . At higher temperature the  $P_{FT,opt}$  locates at higher values, as some trends shown by Haida et al. (2016) and Gullo et al. (2016). On the contrary, in subcritical operation it tends to be lower, as the parallel compression rack becomes less influential. Special care is taken to optimize  $P_{FT}$  and  $P_{GC}$  simultaneously in the following results.

### 3.4 Seasonal COP calculations

Using the system parameters of Table 1 and the aforementioned pressures optimizations, COP results for different  $T_{amb}$  are calculated and shown in Figure 14 for Open Hours and Figure 15 for Closed Hours. To relate each operating point to an ambient temperature, a constant temperature of 1.5 K has been set. This value is in between the range measured in the experimental survey of Dugaria et al. (2019). In sub-critical condition, a minimal  $P_{GC}$  of 45 bar is established, so it does not become unrealistically close to the  $P_{FT}$ . In consequence, below  $T_{amb} = 7^{\circ}\text{C}$ , the sub-cooling increases above the indicated 3 K. Establishing the Booster Layout as a baseline for each operating point, COP improvement

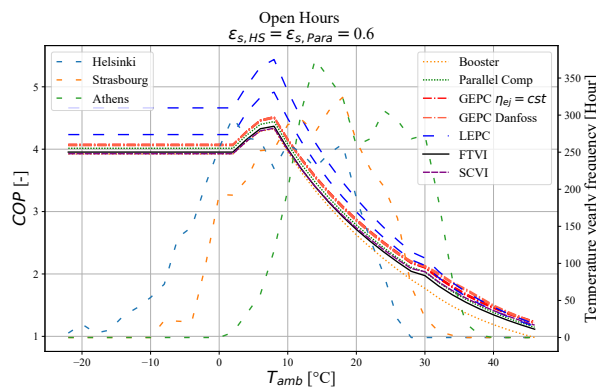

Figure 14: COPs decay with  $T_{amb}$  for each system at Open Hours,  $\varepsilon_{s,HS} = \varepsilon_{s,Para} = 0.6$

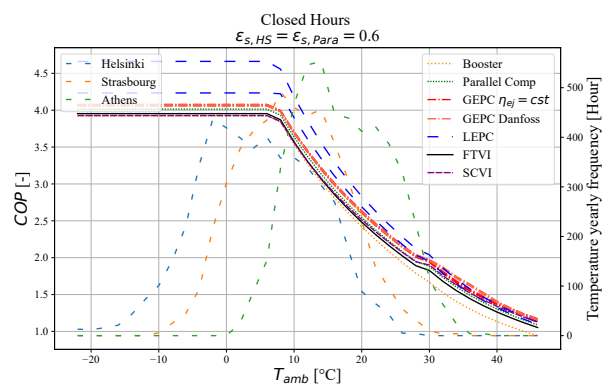
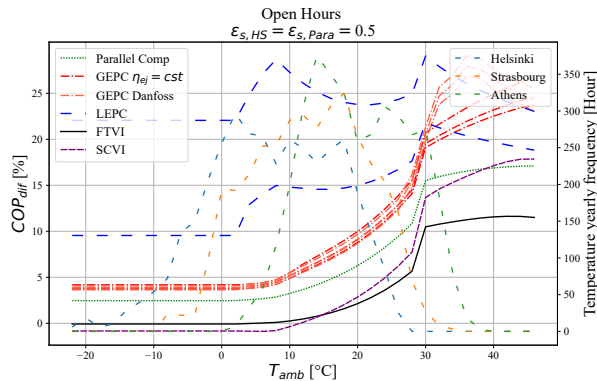

Figure 15: COPs decay with  $T_{amb}$  for each system at Closed Hours,  $\varepsilon_{s,HS} = \varepsilon_{s,Para} = 0.6$

percentage of each system are shown in Figures 16 and 17. The influence of the  $\varepsilon_s$  sensitivity analysis (values: 0.5, 0.6 and 0.7) is observed. As expected, performance increase over the baseline becomes more important as  $T_{amb}$  increases. On the other side, the PC System performance is up to 16% higher than the Basic layout, taking  $\varepsilon_s = 0.7$  as reference. Logically, the GEPC Layout further increases COP to about 17-23% over the Booster Layout at  $T_{amb} = 45^{\circ}\text{C}$ . Figures 16 and 17, also include results of a  $\eta_{ej,gas}$  sensitivity analysis. Three constant efficiencies have been used: 0.18, 0.20 and 0.25.  $\eta_{ej}$  impact is more important at high ambient temperature. On the other hand, Danfoss Data has also been to obtain a  $\eta_{ej,gas}$  profile. On top of this efficiency profile, an uncertainty of  $\pm 3\%$  on that value is calculated with the model. The  $\eta_{ej,gas}$  contour shown in Figure 7 puts in evidence that the design point of the multi-ejector is around  $T_{gc,out} = 35^{\circ}\text{C}$ , where the component's efficiency boosts. Around these temperatures is where the GEPC system shows

better performance, reaching around 25% of COP improvement over the Booster Layout. On its side, the LEPC MT saturation temperature lift sensitivity analysis has been set to +3 and +6 K. Overall, for the selected operating conditions,



**Figure 16:** COP improvement over the Booster cycle for each system at Open Hours,  $\varepsilon_{s,HS} = \varepsilon_{s,Para} = 0.5$

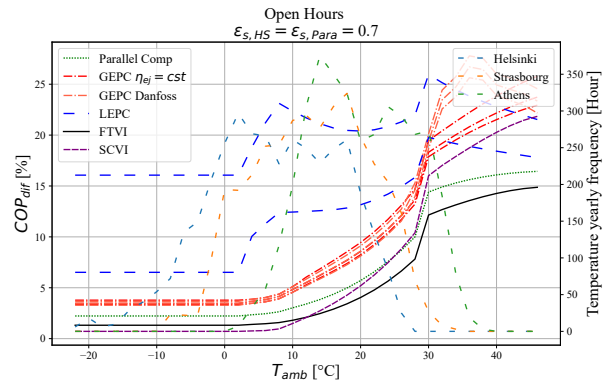

**Figure 17:** COP improvement over the Booster cycle for each system at Open Hours,  $\varepsilon_{s,HS} = \varepsilon_{s,Para} = 0.7$

components' performances and design parameters, VI systems do offer the expected improvement over the Booster Layout. Taking  $\varepsilon_s = 0.7$  as reference, the SCVI layout outperforms the PC System for  $T_{amb} > 25^\circ\text{C}$ . However, when comparing to the GEPC System, the SCVI Layout does show itself inferior in COP across all operating points but still appears competitive to this 3<sup>rd</sup> generation system at very high ambient temperatures: in transcritical operation the benefit over the baseline differs in only a couple of percentage points. Nonetheless, the FTVI layout does not appear to theoretically over perform the Parallel Compression system in high temperature operation.

Regarding HS compressors' sensitivity analysis, results show that increasing  $\varepsilon_s$  will decrease the COP improvement percentage over the Booster Layout of the 3 systems having PC. This may occur because if the baseline Booster has better compressors, there is less penalty on a single high ratio compression. On the contrary, for VI systems, higher efficiency HS compressors increase the percentage of  $COP_{diff}$  over the baseline. As a result, higher efficiency compressors makes VI systems more competitive towards ME solutions, considering same  $\varepsilon_s$  for every system.

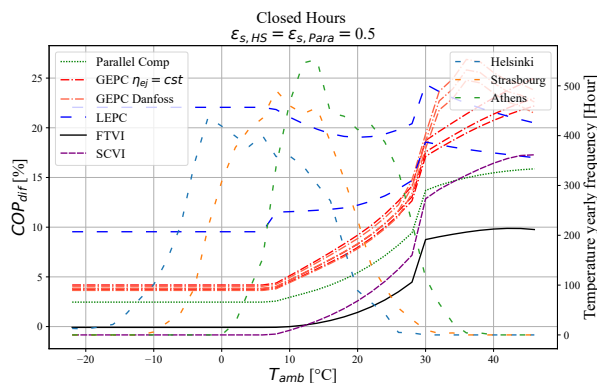

**Figure 18:** COP improvement over the Basic cycle for each system at Closed Hours,  $\varepsilon_{s,HS} = \varepsilon_{s,Para} = 0.5$

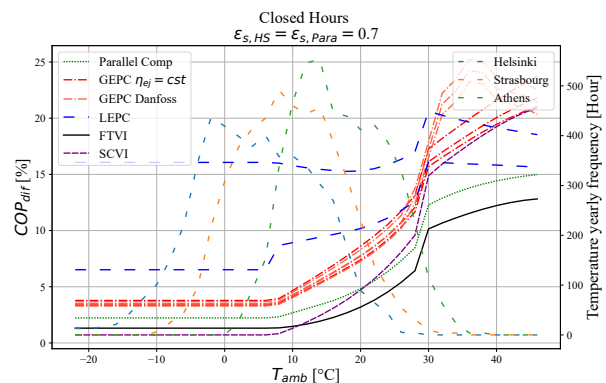

**Figure 19:** COP improvement over the Basic cycle for each system at Closed Hours,  $\varepsilon_{s,HS} = \varepsilon_{s,Para} = 0.7$

Ambient temperatures bin hours frequency used for SCOP calculations are shown in Figure 16 and Figure 17. Results and Energy savings with respect to the Booster Layout are presented in Table 2. Sensitivity analysis results are also included:  $\varepsilon_s$  of the HS and PC compressors is considered, whilst the *sec* column varies for  $\eta_{ej}$  in the GEPC system and the MT temperature lift for the LEPC system. As expected, for every system, energy savings increases for a warmer climate. The only system that presents a considerable energy saving for each climate is the LEPC Layout. This happens because its main effect is to increase  $T_{ev,MT}$ , which has been set as a constant lift across all operating points. However,



sensitivity analysis considers a lift of +3 and +6 K. On the other side, the LEPC system offers little increase in Energy Saving for a warmer climate with respect to the GEPC System. This is due to the fact that the Liquid Ejector diminishes the vapour quality in the Flash Tank, while it is the contrary for the Gas Ejector. This results in lower available gas for the PC rack, and thus, lower benefit by recirculating flow at lower compression ratio. With respect to the VI systems, the models suggest that the FTVI Layout has slightly inferior SCOP than the 2<sup>nd</sup> generation of R744 systems, and thus, providing lower energy saving. On its side, the SCVI layout performance indicators also leaves it behind the 2<sup>nd</sup> and 3<sup>rd</sup> generation of R744 systems.

However, for the system layouts that have PCs, results are shown in two hypothetical cases: "Ideal" and "Realistic". The "Ideal" case considers the COP's previously presented, while the "Realistic" considers the fact that normally these systems can not operate the PC rack below  $T_{amb} \approx 27^\circ$  because there is simply too little gas for the compressors to work. For this operating range, the COP is downgraded to the Booster Layout results, with the exception of the LEPC system, where its performance has to be recalculated without PC. The authors would like to point out that even if this scenario is more realistic, for different climates the PC racks should be sized differently, resulting in different  $T_{amb}$  limit. After applying this scenario's constraints, overall conclusions change. The PC layout SCOP decreases from 2.72 to 2.61, the GEPC system SCOP passes from 2.79 to 2.63 and the LEPC System SCOP diminishes from 2.90 to 2.63. This results in reducing the energy savings of these three system in more than half. The 4.08% and 5.35% energy saving from the baseline of the FTVI and SCVI systems, now, in this scenario, stands favourably against 2.70 %, 3.77 % and 3.22% of the PC, GEPC (Danfoss) and LEPC systems. It is important to consider that this "realistic scenario" towards the systems having PC racks, still is theoretical and idealistic towards VI system, as it still considers that VI can be done at any condition. Thus, VI systems would be competitive under this premise.

**Table 2:** Seasonal Performance Indicators

		Helsinki		Strasbourg		Athens		
		$\varepsilon_s^a$	sec <sup>b</sup>	$\varepsilon_s$	sec	$\varepsilon_s$	sec	
SCOP	Ideal	Booster	3.03  <b>3.50</b>  3.93	-  <b>3.50</b>  -	2.74  <b>3.17</b>  3.58	2.74  <b>3.17</b>  3.58	2.18  <b>2.54</b>  2.89	-  <b>2.54</b>  -
		Parallel Comp.	3.14  <b>3.62</b>  4.06	-  <b>3.62</b>  -	2.86  <b>3.31</b>  3.73	-  <b>2.86</b>  -	2.33  <b>2.72</b>  3.08	-  <b>2.72</b>  -
		Gas Ejector	3.20  <b>3.68</b>  4.13	3.68  <b>3.68</b>  3.70	2.93  <b>3.38</b>  3.81	2.93  <b>3.38</b>  3.81	2.40  <b>2.79</b>  3.16	2.78  <b>2.79</b>  2.81
		Gas Ej. (Danfoss)	3.20  <b>3.68</b>  4.13	3.67  <b>3.68</b>  3.69	3.37  <b>3.38</b>  3.40	2.41  <b>2.80</b>  3.18	2.41  <b>2.80</b>  3.18	2.79  <b>2.80</b>  2.82
		Liquid Ejector	3.46  <b>3.94</b>  4.38	<b>3.94</b>  4.24	3.13  <b>3.59</b>  4.01	<b>3.59</b>  3.85	2.50  <b>2.90</b>  3.27	<b>2.90</b>  3.08
		FTVI	3.05  <b>3.55</b>  4.01	-  <b>3.55</b>  -	2.24  <b>2.65</b>  3.03	-  <b>3.24</b>  -	2.24  <b>2.65</b>  3.03	-  <b>2.65</b>  -
	SCVI	3.04  <b>3.54</b>  4.01	-  <b>3.54</b>  -	2.78  <b>3.25</b>  3.70	-  <b>3.24</b>  -	2.27  <b>2.69</b>  3.08	-  <b>2.69</b>  -	
	Realistic	Parallel Comp.	3.03  <b>3.50</b>  3.93	-  <b>3.50</b>  -	2.75  <b>3.18</b>  3.59	-  <b>3.18</b>  -	2.24  <b>2.61</b>  2.97	-  <b>2.61</b>  -
		Gas Ejector	3.03  <b>3.50</b>  3.93	-  <b>3.50</b>  -	2.75  <b>3.19</b>  3.60	-  <b>3.19</b>  -	2.26  <b>2.63</b>  2.99	2.63  <b>2.63</b>  2.64
		Gas Ej. (Danfoss)	3.03  <b>3.50</b>  3.93	3.50  <b>3.50</b>  3.50	2.75  <b>3.19</b>  3.60	3.19  <b>3.19</b>  3.19	2.26  <b>2.64</b>  3.00	2.64  <b>2.64</b>  2.65
		Liquid Ejector	3.13  <b>3.59</b>  4.00	-  <b>3.59</b>  3.90	2.80  <b>3.22</b>  3.62	<b>3.22</b>  3.49	2.26  <b>2.63</b>  2.97	<b>2.63</b>  2.82
		Parallel Comp.	3.49  <b>3.32</b>  3.17	-  <b>3.49</b>  -	4.42  <b>4.20</b>  4.01	-  <b>4.20</b>  -	6.77  <b>6.46</b>  6.18	-  <b>6.46</b>  -
Gas Ejector		5.25  <b>5.04</b>  4.84	4.80  <b>5.04</b>  5.50	6.44  <b>6.20</b>  5.97	5.99  <b>6.20</b>  6.74	9.25  <b>8.94</b>  9.32	8.67  <b>8.94</b>  9.62	
Energy Savings	Ideal	Gas Ej. (Danfoss)	5.27  <b>5.06</b>  4.86	4.79  <b>5.06</b>  5.33	6.50  <b>6.26</b>  6.03	5.94  <b>6.26</b>  6.58	9.64  <b>9.32</b>  9.02	8.91  <b>9.32</b>  9.74
		Liquid Ejector	12.3  <b>11.4</b>  10.4	<b>11.4</b>  17.6	12.6  <b>11.6</b>  10.8	<b>11.6</b>  17.5	13.1  <b>12.3</b>  11.5	<b>12.3</b>  17.4
		FTVI	0.53  <b>1.46</b>  2.03	-  <b>1.46</b>  -	1.17  <b>2.14</b>  2.73	-  <b>2.14</b>  -	3.06  <b>4.08</b>  4.67	-  <b>4.08</b>  -
		SCVI	0.29  <b>1.36</b>  2.03	-  <b>1.36</b>  -	1.34  <b>2.46</b>  3.16	-  <b>2.46</b>  -	4.18  <b>5.35</b>  6.08	-  <b>5.35</b>  -
		Parallel Comp.	0.01  <b>0.01</b>  0.01	-  <b>0.01</b>  -	0.40  <b>0.38</b>  0.36	-  <b>0.38</b>  -	2.83  <b>2.70</b>  2.58	-  <b>2.70</b>  -
		Gas Ejector	0.01  <b>0.01</b>  0.01	0.01  <b>0.01</b>  0.01	0.50  <b>0.48</b>  0.46	0.47  <b>0.48</b>  0.51	3.55  <b>3.41</b>  3.28	3.33  <b>3.41</b>  3.61
	Realistic	Gas Ej. (Danfoss)	0.01  <b>0.01</b>  0.01	0.01  <b>0.01</b>  0.01	0.54  <b>0.52</b>  0.50	0.50  <b>0.52</b>  0.54	3.91  <b>3.77</b>  3.64	3.64  <b>3.77</b>  3.90
		Liquid Ejector	3.33  <b>2.64</b>  1.93	<b>2.60</b>  10.4	2.18  <b>1.57</b>  1.00	<b>1.57</b>  9.14	3.77  <b>3.22</b>  2.69	<b>3.22</b>  9.78

<sup>a</sup> HS and PC compressors isentropic efficiency sensitivity analysis set to 0.5, 0.6, and 0.7.

<sup>b</sup> Secondary sensitivity analysis. For GEPC systems, it is the ejector efficiency. For the LEPC systems, it is the MT evaporating temp.

## 4. CONCLUSIONS

- The potential of a somewhat disregarded R744 system solution, FTVI and SCVI in a booster-like configuration, has been studied by means of simulation models. Models are primarily oriented at comparing the thermodynamic cycles. To the authors knowledge, these solutions have never been directly compared with the existing generation

of CO<sub>2</sub> refrigeration systems for supermarket applications, as this paper does.

- COP results are used for SCOP prediction for the climate of Helsinki, Strasbourg and Athens. Two scenarios are presented: "Ideal", where parallel compression racks do not have operating limits, and "Realistic" where they can not operate below  $T_{amb} = 27^{\circ}C$ .
- Sensitivity analyses on some of the different adopted hypotheses have been conducted to understand if they could affect the final conclusions. High-stage and parallel compressors isentropic efficiency, and the gas ejector efficiencies, have the most influence. Notably, for higher compressors' efficiency, systems with PC decrease its energy savings with respect to the baseline Booster system, whilst the VI systems increase theirs.
- The "Ideal" scenario describes both VI systems as inferior to the 2<sup>nd</sup> and 3<sup>rd</sup> generation systems for all 3 studied climates. However, once the "realistic" scenario restrictions are applied, most of the energy benefits of the PC, GEPC and LEPC systems become only considerable for the warmer climate. VI systems, without restrictions applied in this scenario, present the highest energy savings. In Athens, FTVI and SCVI layouts present 4.08% and 5.35% energy savings with respect to the baseline Booster system, whilst the GEPC, presents up to 3.77%.
- More research is still to be done to understand the benefits and challenges of FTVI and SCVI in booster-like applications. Possible combinations with ejectors and parallel compressors have also not been explored.

## 5. NOMENCLATURE

MT	Medium Temperature	<b>Greek Symbols</b>	
HS	High-Stage	$\eta$	Efficiency
FT	Flash Tank	$\varepsilon$	Isentropic Efficiency
P	Pressure	$\varphi$	Entrainment ratio
PC	Parallel Compressors/Compression	<b>Subscript</b>	
GEPC	Gas Ejector Parallel Compression	amb	ambient
GC	Gas Cooler	ej	ejector
LEPC	Liquid Ejector Parallel Compression	opt	optimized
LT	Low Temperature	FT	flash tank
ME	Multi-Ejector	gas	gas
FTVI	Flash Tank Vapour Injection	GC	gas cooler
SCOP	Seasonal Coefficient of Performance	liq	liquid
SCVI	Sub-cooled Vapour Injection	out	outlet/exhaust
sec	Secondary sensitivity parameter	pot	potential
T	Temperature	r	ratio
V	Volume	rec	recovered
		s	isentropic

## REFERENCES

- Baek, C., Heo, J., Jung, J., Cho, H., and Kim, Y. (2014a). Effects of the cylinder volume ratio of a twin rotary compressor on the heating performance of a vapor injection CO<sub>2</sub> cycle. *Applied Thermal Engineering*, 67(1):89 – 96.
- Baek, C., Heo, J., Jung, J., Lee, E., and Kim, Y. (2014b). Effects of vapor injection techniques on the heating performance of a CO<sub>2</sub> heat pump at low ambient temperatures. *International Journal of Refrigeration*, 43:26 – 35.
- Baek, J., Groll, E., and Lawless, P. (2002). Effect Of Pressure Ratios Across Compressors On The Performance Of The Transcritical Carbon Dioxide Cycle With Two-State Compression And Intercooling. In *International Refrigeration and Air Conditioning Conference*. Purdue e-Pubs.
- Cavallini, A., Cecchinato, L., Corradi, M., Fornasieri, E., and Zilio, C. (2005). Two-stage transcritical carbon dioxide cycle optimisation: A theoretical and experimental analysis. *International Journal of Refrigeration*, 28(8):1274 – 1283.
- Cecchinato, L., Chiarello, M., Corradi, M., Fornasieri, E., Minetto, S., Stringari, P., and Zilio, C. (2009). Thermodynamic analysis of different two-stage transcritical carbon dioxide cycles. *International Journal of Refrigeration*, 32(5):1058 – 1067.

- Dugaria, S., Azzolin, M., Calabrese, L., Minetto, S., and Col, D. D. (2019). Monitoring of a CO<sub>2</sub> commercial refrigeration system serving a supermarket in Souther Europe. In Minea, V., editor, *The 25<sup>th</sup> IIR INternational Congress of Refrigeration*. International Institute of Refrigeration IIR.
- Elbel, S. and Hrnjak, P. (2008). Experimental validation of a prototype ejector designed to reduce throttling losses encountered in transcritical r744 system operation. *International Journal of Refrigeration*, 31(3):411 – 422.
- Elbel, S. and Hrnjak, P. (2020). Improvement of capacity and cop through use of two-stage compressor in transcritical r744 systems. In *Proceedings of the IIR International Rankine 2020 Conference - Heating, Cooling and Power Generation*. International Institute of Refrigeration IIR.
- Gullo, P., Elmegaard, B., and Cortella, G. (2016). Energy and environmental performance assessment of r744 booster supermarket refrigeration systems operating in warm climates. *International Journal of Refrigeration*, 64:61 – 79.
- Gullo, P., Hafner, A., and Banasiak, K. (2018). Transcritical R744 refrigeration systems for supermarket applications: Current status and future perspectives. *International Journal of Refrigeration*, 93:269 – 310.
- Haida, M., Banasiak, K., Smolka, J., Hafner, A., and Eikevik, T. M. (2016). Experimental analysis of the r744 vapour compression rack equipped with the multi-ejector expansion work recovery module. *International Journal of Refrigeration*, 64:93 – 107.
- Hwang, Y. H., Celik, A., and Radermacher, R. (2004). Performance of CO<sub>2</sub> Cycles with a Two-Stage Compressor. In *International Refrigeration and Air Conditioning Conference*. Purdue e-Pubs.
- Liu, S., Lu, F., Dai, B., Nian, V., Li, H., Qi, H., and Li, J. (2019). Performance analysis of two-stage compression transcritical CO<sub>2</sub> refrigeration system with R290 mechanical subcooling unit. *Energy*, 189:116143.
- Liu, S., Sun, Z., Li, H., Dai, B., and Chen, Y. (2017). Thermodynamic analysis of co<sub>2</sub> transcritical two-stage compression refrigeration cycle systems with expanders. *HKIE Transactions*, 24(2):70–77.
- Mizuno, H., Murakami, K., Kawanishi, A., Ichigaya, K., Ikeda, M., and Enya, A. (2017). Development of HCCV1001 Commercial Condensing Unit Employing CO<sub>2</sub> as Natural Refrigerant. Technical review, Mitsubishi Heavy Industries.
- Pitarch, M., Navarro-Peris, E., Gonzalvez, J., and Corberan, J. (2016). Analysis and optimisation of different two-stage transcritical carbon dioxide cycles for heating applications. *International Journal of Refrigeration*, 70:235 – 242.
- Sharma, V., Fricke, B., and Bansal, P. (2014). Comparative analysis of various co<sub>2</sub> configurations in supermarket refrigeration systems. *International Journal of Refrigeration*, 46:86 – 99.
- Skačánová, K. Z. and Battesti, M. (2019). Global market and policy trends for CO<sub>2</sub> in refrigeration. *International Journal of Refrigeration*, 107:98 – 104.
- Tashibana, H. (2015). Introduction of Panasonic New CO<sub>2</sub> refrigeration system (Technical Part). Atmosphere asia 2015 report, Panasonic Corporation - Refrigeration and Air-Conditioning Devices Business Division.
- Threlkeld, J. L. (1962). *Thermal environmental engineering*. Prentice-Hall International, Englewood (NJ).
- Xing, M., Yu, J., and Liu, X. (2014). Thermodynamic analysis on a two-stage transcritical co<sub>2</sub> heat pump cycle with double ejectors. *Energy Conversion and Management*, 88:677 – 683.
- Yang, L., Li, H., Cai, S.-W., Shao, L.-L., and Zhang, C.-L. (2015). Minimizing cop loss from optimal high pressure correlation for transcritical co<sub>2</sub> cycle. *Applied Thermal Engineering*, 89:656 – 662.

## ACKNOWLEDGMENT

This work was funded by the National Agency for Research and Development (ANID) / Scholarship Program / DOCTORADO BECAS CHILE/2017 - 72180512.