

See discussions, stats, and author profiles for this publication at: <https://www.researchgate.net/publication/225121626>

An Enhanced Robotic Library System for an Off-Site Shelving Facility

Chapter · July 2006

DOI: 10.1007/10991459_42 · Source: DBLP

CITATIONS
10

READS
52

5 authors, including:



Jackrit Suthakorn

Mahidol University

68 PUBLICATIONS 384 CITATIONS

SEE PROFILE



Yu Zhou

State University of New York Institute of Techn...

42 PUBLICATIONS 637 CITATIONS

SEE PROFILE



Sayeed Choudhury

Johns Hopkins University

58 PUBLICATIONS 348 CITATIONS

SEE PROFILE



Gregory S. Chirikjian

Johns Hopkins University

326 PUBLICATIONS 7,878 CITATIONS

SEE PROFILE

Some of the authors of this publication are also working on these related projects:



Breast Biopsy Navigation and Robotics System [View project](#)



Dental Implant Navigation System [View project](#)

All content following this page was uploaded by [Sayeed Choudhury](#) on 18 September 2017.

The user has requested enhancement of the downloaded file.

An Enhanced Robotic Library System for an Off-Site Shelving Facility

Jackrit Suthakorn¹, Sangyoon Lee², Yu Zhou², Sayeed Choudhury³, Gregory S. Chirikjian²

¹Department of Mechanical Engineering, Mahidol University, Bangkok Thailand

²Department of Mechanical Engineering, ³Digital Knowledge Center of the Sheridan Libraries
The Johns Hopkins University, Baltimore, Maryland 21218 USA

Abstract

This paper describes our continued work of a unique robotics project, Comprehensive Access to Printed Materials (CAPM), within the context of libraries. As libraries provide a growing array of digital library services and resources, they continue to acquire large quantities of printed material. This combined pressure of providing electronic and print-based resources and services has led to severe space constraints for many libraries, especially academic research libraries. Consequently, many libraries have built or plan to build off-site shelving facilities to accommodate printed materials. An autonomous mobile robotic library system has been developed to retrieve items from bookshelves and carry them to scanning stations located in the off-site shelving facility. This paper reviews the overall design of the robot system and control systems, and reports the new improvement in the accuracy of the robot performance; in particular, the pick-up process.

1. Introduction

As libraries provide a growing array of digital library services and resources, they continue to acquire large quantities of printed material. This combined pressure of providing electronic and print-based resources and services has led to severe space constraints for many libraries, especially academic research libraries. Consequently, many libraries have built or plan to build off-site shelving facilities to accommodate printed materials. However, given that these locations are not usually within walking distance of the main library, access to these materials, specifically the ability to browse, is greatly reduced. Libraries with such facilities offer extensive physical delivery options from these facilities, sometimes offering multiple deliveries per day. Even with such delivery options, the ability to browse in real-time remains absent. The goal of the CAPM Project is to build a robotic, on-demand and batch scanning system that will allow for real-time browsing of printed materials through a web interface. We envisage the system will work as follows: an end user will identify that a monograph is located in an off-site facility. The user will engage the CAPM system that, in turn, will initiate a robot that will retrieve the requested item. The robot will deliver this item to another robotic system that will open the item and turn the pages automatically. By using existing scanners, optical character recognition (OCR) software, and indexing software

developed by the Digital Knowledge Center (a research and development unit of the Sheridan Libraries at Johns Hopkins), the CAPM system will not only allow for browsing of images of text, but also for searching and analyzing of full-text generated from the images.

The details of the mechanical structure, the navigation system, control and software, simulations, experiments and results of the robot were previously described in [1]. This paper focuses on improvement in the accuracy of entire delivery procedure of the robot system, in particular, the pick-up of bookcases, while the future work, will be concentrated on developing the robotic system to complete the remaining processes.

Since the CAPM robot is designed to work in an off-site shelving facility that belong to the Johns Hopkins University, several assumptions in the design are made based on the actual environment of this facility. All the paths in the facility are assumed to be smooth and flat. Each book is assumed to be stored in a special case, which has a pair of wing-like handles for engaging with a passive gripper. It is assumed that each item is stored in a specifically designed case and arranged side-by-side with a small in-between gap. Finally, a barcode is attached to each case.

Currently at the Moravia Park shelving facility, after receiving a request, a library officer at the facility will drive a portable personnel lift to retrieve the requested item to its location, and then bring it to a waiting area for the next scheduled transportation. Then, a batch of requested items is transferred to the main library. In the same manner, our robot will be initially parked at the docking station until an item is requested. The robot is equipped with a database system of book locations and a global map of the off-site shelving facility. After receiving a request, the robot will autonomously run along a known path to the book location and retrieve the requested item from the shelf. Then, the robot will carry the item back to the scanning station and then return to the docking station.

This is not the first time a robot has been built to perform a specific service function. In 1995, Hansson introduced an industrial robot in a Swedish library [2]. Safaric [3] presented an example of a telerobot controlled via Internet [4]. Byrd introduced a successful service robot used to survey and inspect drums containing low-level radioactive waste stored in warehouses at Department of Energy facilities [5].

The CAPM system differs from other existing systems in the following ways. First, the system retrieves individual items, as opposed to boxes of items, such as the system at the California State University at Northridge [6]. Second, the CAPM system does not assume an existing or fixed shelving and space arrangement. This flexibility will allow it to work in many diverse environments. Third, the CAPM retrieval robot is an autonomous system. Fourth, the economic analysis by a collaborating research group in the Department of Economics at Johns Hopkins University has verified that a *relatively* inexpensive robotic system is cost-effective, especially in comparison to potential benefits. Finally, the page-turning system, to be built in the future, will accommodate a wide variety of paper types and materials.

In subsequent sections of this paper, we report the design, control systems, experiments and results of an autonomous robotic library system for an off-site shelving facility. Sections 2 and 3 briefly review the robot design, the robot control systems and software and navigation system (detailed descriptions can be found in [1, 6].) Section 4 explains improvement in the accuracy of entire delivery procedure of the robot system. We then report experiments and results in Section 5.

2. Hardware of the Robotic System

2.1 Mechanical Structure

This section presents designs and descriptions of two major components of the CAPM library robot: the manipulator arm and the locomotion device.

2.1.1 Manipulator arm system

In order to retrieve books from bookshelves and carry them to the scanning station, a specific manipulator arm system was designed. Since each bookshelf is 10-foot-high, a vertical translation system (VTS) was used to move the robot manipulator to different altitudes. The VTS is a sliding rod with an electric motor for driving a lead-screw rod. An enhanced commercial 6-DOF robot manipulator, the F3 made by CRS Robotics, Inc., is affixed to a platform which is a part of the vertical translation system (See Figure 1.)

We built and installed a passive gripper to the end-effector of the robot manipulator. The gripper is used to passively grasp the bookcase. The structures of the gripper and bookcases were designed to fit to each other. A barcode scanner is installed inside the gripper in order to recognize and ensure the precision of picking a requested item.

2.1.2 Locomotion device

The locomotion device is responsible for the gross motion of the robot. We have modified a commercial servo-controlled mobile robot platform, the Labmate made by Helpmate Inc. An aluminum-alloy cart is built and attached

to the Labmate mobile platform. This cart is used to store the robot manipulator controller and the power source while the Labmate mobile platform is used as the base of the manipulator arm system. A ranging sensor system was installed on the mobile platform to collaborate and improve the navigation system. All electronic devices used to control the vertical translation system and sensor systems were installed on the mobile platform. Because of the installation of a power source onboard, the robot does not require an external power line while working. Figure 1 shows the overall mechanical structure of the library robot.

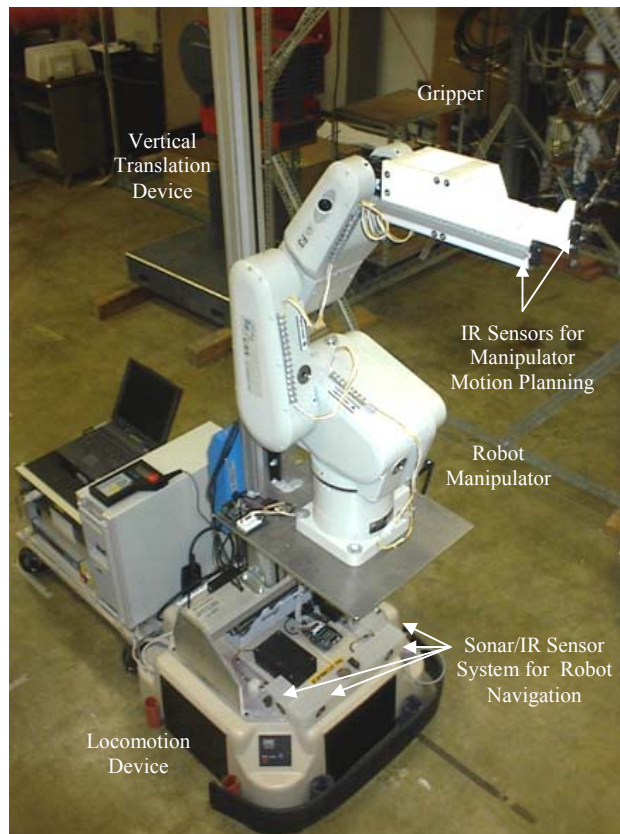

Figure 1: The Robotic Library System

2.2 Navigation System

In its operation, the robot will follow paths based on a global map. The robot is taught to know the global map of the experiment areas such as the docking area, paths to bookshelves, and the book-table destination. As in any system where we state a trajectory and expect the system to follow it, perturbations can cause deviation from the programmed route. In order to counteract any disturbances and stay on a trajectory that is as close to the desired path as possible, a simple feedback control system is employed using four range sensor measurements.

Two are from the front side of the mobile platform. The other two are from the left and right side of the mobile platform.

In our work, due to limits of sensor performance, 8 sensors are used: 4 sonar sensors and 4 infrared sensors. One sonar and one infrared sensor are paired together to get each of the 4 sensor readings needed. This is done because of the distance measuring limits which each have. The Polaroid 6500 sonar sensor has a range of 15-1067 cm while the Sharp GP2D02 infrared sensor has a range of 10-80 cm. It can be observed that by using these two sensors combined, we can achieve a range of 10-1067 cm of reliable distance measurement. Each sensor is controlled and interfaced to the main computer via a micro-controller (BASIC Stamp II).

3. Control and Software

All the processes and activities of the system are controlled by an onboard Intel Pentium II laptop. The control systems of the library robot consist of several sub-controllers: the control system of the VTS, the control system of the robot manipulator, the control system of the mobile platform, the high-level control system of the library robot, and the control software.

3.1 Control of the VTS

The VTS is required in the library robot to move the robot manipulator to different altitudes. A lead screw lift system was selected and modified to be a major component of the VTS. To enhance the lift system so that it could successfully be implemented as part of an autonomous robotic library system, a feedback control system was integrated. This feedback control system functions to: 1) determine the altitude of the VTS platform, 2) send the real-time ranging information to the high-level controller, and 3) receive a command from the high-level controller to control the motion of the VTS platform in order to reach a desired altitude. The feedback control system of the VTS consists of a BASIC Stamp II micro-controller, an input/output serial communication port, a range sensor system, and a VTS directional controller.

3.2 Control of the Robot Manipulator

The six-axis F3 robot system manufactured by CRS Robotics Inc is used as the control system of the robot manipulator. Articulated joints provide the F3 arm with six degrees of freedom, and absolute encoders mounted on the motor shaft in each joint provide positional feedback to the controller. The F3 robot arm uses the Cartesian coordinate system.

Control programs were written in the C++ language and downloaded to the controller. Control programs use the ActiveRobot interface developed by CRS robotics and include two object classes of the ActiveRobot interface: one provides the application with the main interface to the robot system, and the other enables the application to create and modify robot locations. The input variables to the control programs are the speed and the position and

orientation of the final location of the end-effector. The controller provides the computation of inverse kinematics.

3.3 Control of the Mobile Platform

The locomotive device, or the mobile platform Labmate, has the drive system microprocessor that the user's host computer communicates with through an RS-232 serial port. The host computer always initiates communications between the host computer and the Labmate. The Labmate uses a Cartesian coordinate system for position control. The coordinate system is a global reference that is initialized at power up and reset. Odometry (dead reckoning) is the practice of calculating position from wheel displacements. The Labmate control system depends on encoders mounted on each wheel to keep track of position. Control programs are basically composed of commands that direct the Labmate to a particular location. We assume here that the entire map of the workspace is stored in the form of a look-up table in the memory of the Labmate. If a destination is given, the Labmate computes the direction from the current location by referring to the look-up table. To compensate for the errors, we used two kinds of sensors: ultrasonic ranging sensors and infrared sensors. For more successful navigation of an autonomous vehicle over extended distances, references to the external world at regular intervals are necessary. Figure 2 illustrates the diagram of the library robot controls.

3.4 Control Systems of the Library Robot

We call the main control system of the library robot the "high-level control system". This control system consists of a Pentium II 233 MHz computer notebook and a serial port splitter hub. The computer notebook functions as the central processing unit of the library robot, and it communicates to every subsystem through the serial ports.

3.5 Control software

The control software is designed based on the idea of event driven programming. Principally, the main control program controls the mobile platform, the vertical translation device, and the arm through serial ports. When the main control program begins to run, it initializes the serial ports of the computer at first and starts the event listeners for all the serial ports. Then the main control program leaves the control to the listeners. It is actually these event listeners that control the movement of the platform, the vertical translation device, and the arm. Basically, each event listener will monitor the status of one serial port. Once the status of that port changes, the listener will judge what kind of event happens and execute a corresponding function. We use the word 'lift' interchangeably with 'the vertical translation device'.

An important property of event driven programming is that the execution order of the functions is not fixed, it depends on the need to execute. This property is suitable for the sensor driven system of the library robot. In total four

event listeners are created. They monitor the status of the platform, the lift, the arm, and the sensors respectively. Figure 3 shows the software structure of the robot.

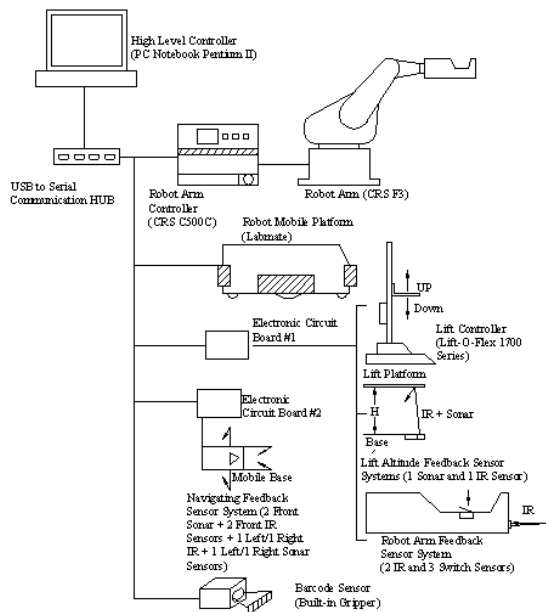

Figure 2: Diagram of the library robot controls.

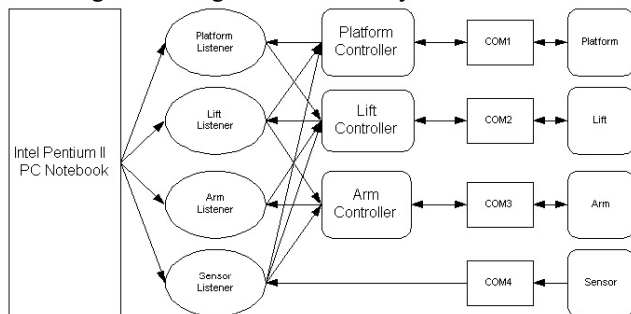

Figure 3: Software structure of the library robot.

4. Improvement in the Accuracy of the Book Pick-Up Process

To assist the motion planning of the library robot, the complete working process of the library robot was simulated using 3DSMAX. Based on the simulation, a complete path was generated, and experiments were executed to test and adjust the performance of the robot. To simplify the implementation, a map-based scheme was employed to control the mobile platform. A fixed global coordinate system is defined with its origin at the docking spot. The positions of the intermediate stops and the destination were defined in the global system. An optimal path was chosen to connect the current stop and the next stop. The major problem appearing in the experiments is positioning error. It was found that the positioning error was closely related to the moving speed of the platform. If

the speed was low, the motor may lose some steps because of the certain heavy overall load. If the speed was high, the platform may deviate from the desired path at the turning corners because of the inertia. After a few adjustments of the speed setting, the positioning was improved considerably.

To enhance the accuracy of pick-up process in the robot manipulator controls, we integrated an infrared sensing system to the manipulator. The infrared sensing system consists of two infrared sensors (Sharp GP2D02), the sensor controller, and an input/output serial COM port to communicate with the high-level controller. The two infrared sensors were attached to the fingertips of the end-effector, and are controlled by a circuit controller made of a BASIC Stamp II microchip and other required circuitry components. Figure 4 shows a picture of the IR sensors installed on the gripper. The high-level controller communicates with the infrared sensing system through the I/O serial com port. The high-level controller receives the ranging information from the sensor and converts this information to an updated data file.

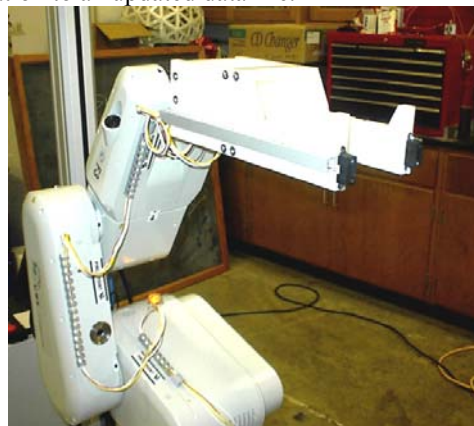

Figure 4: IR sensors installed on the gripper.

In the pick-up process, once the library robot reaches the position in front of the desired bookshelf, the robot (which already has the desired book's coordinates) starts the pick-up process. However, to eliminate the error that may occur by slightly miss-positioning the book, the book-position-scanning process was added.

Because the manipulator picks up a book in the same manner as a forklift, the positioning of the book is critical. Figure 5 shows the motion planning of the robotic manipulator in the pick-up process. The book-position-scanning process is a process to correct the book-positioning errors. This allows the book to be placed in a specific ranging position instead of only at an exact position. The control architecture of the book-position-scanning process is illustrated in Figure 6.

The book-position-scanning process normally begins with the scanning a certain range of the bookshelf by the IR sensors. The robot uses the known book position stored in its database as the reference position. The manipulator begins scanning from left to right in the horizontal direction relative to the reference position. The scanning path starts at

the position located at 40 mm to the left of the reference position, and then moves to the position located at 40 mm to the right of the reference position, stopping at every 5 mm increment. This scanning creates 17 positions along the path. All of these positions are located in the same X-Z plane, which means that only the X-coordinate values vary. At each stop, the median of distance data is calculated and stored in the computer. After the scanning is finished, a set of median distance values is used to find the exact range of the bookcase.

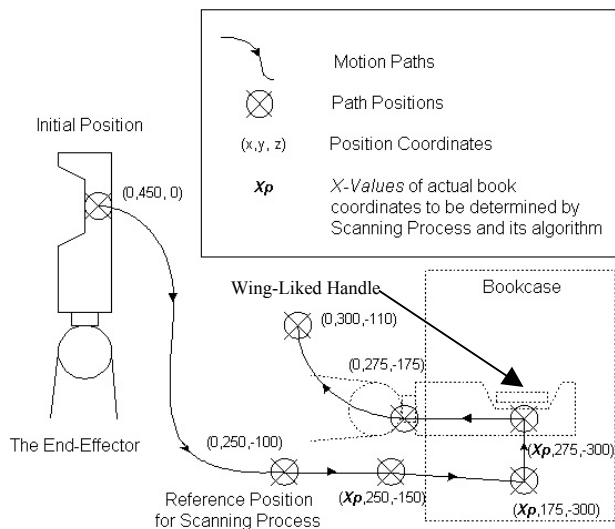

Figure 5: Motion planning of the robotic manipulator in the pick-up process.

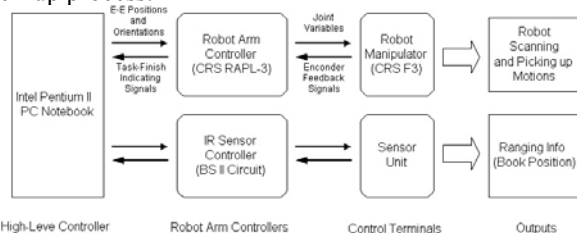

Figure 6: Control architecture of the manipulator's sensing system.

We developed a computer algorithm for the process and obtained remarkable improvement in accuracy from tests. The algorithm was implemented in C++ to control the scanning path of the robot manipulator. The code picks up the data information from infrared sensing system and analyzes these data to generate an actual book location at the end. Once the actual book location is generated, the robot updates the pick-up book position and executes picking-up the book.

5. Experiment and Results of the New Improving Pick-Up Process

Experiments on the robot manipulator were conducted to determine the accuracy of the pick-up process performed by the manipulator and its feedback control system. The

experimental set-up, results, and error analysis are described below.

To verify the accuracy of the pick-up process, we set up the experiment by placing the library robot in the perpendicular direction to the bookshelf (see Figure 7.) The robotic manipulator and its feedback control are designed to be able to scan and pick up a bookcase in a certain range of -40 mm to +40 mm from the reference point, where this range is called "active range." The active range is located on a bookshelf by marking the far-left, reference, and far-right positions, along with a set of fine measurements in increments of 5 mm.

In each experiment, a bookcase was randomly placed in the active range. We recorded the number of successful and failed trials in attempting to pick up a bookcase at each position. We performed the experiments three times at each position, without order of positioning. Figure 7 shows the experiment set-up of the robotic manipulator tests, and in the following part the experimental results will be described.

There are no failed trials (out of 51 trials) in this experiment. Figure 8 shows the step-by-step picking up process of the experiment. The robot manipulator started at its initial position and begins scanning from far-left to far-right positions. After the algorithm determines and finds the actual book position, the robot manipulator executed the picking-up process.

6. Conclusion

An autonomous robotic library system was built as a prototype. The robot design, control systems, simulations, experiments and results were presented. An implementation using IR sensors and a new algorithm to enhance the accuracy of an operation process, book pick-up process, was described, and reported its successful experimental results.



Figure 7: Picture shows the experiment set up for testing the robotic manipulator.

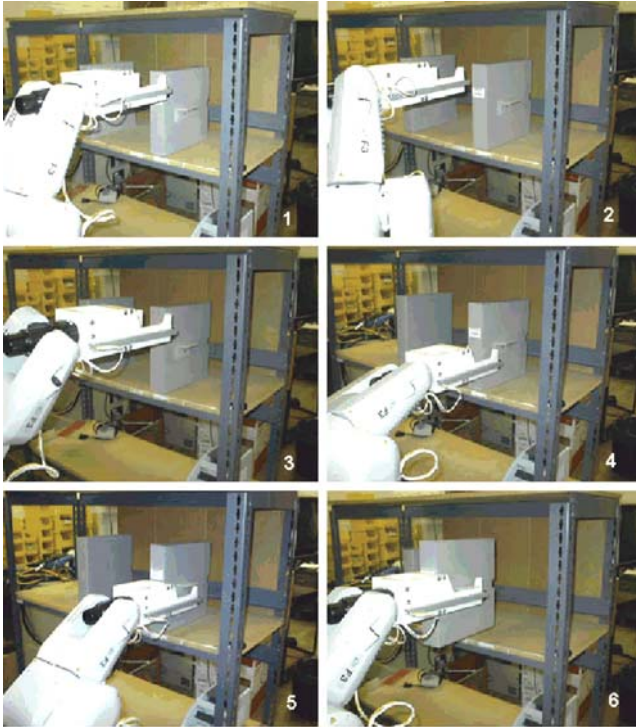

Figure 8: Picture shows step-by-step in pick-up experiment: 1) Manipulator starts at the process's initial position, 2) Manipulator starts the scanning process from the far-left position, 3) Manipulator finishes the scanning process at the far-right position, 4) Manipulator begins picking up the bookcase 5) During the pick-up process, and 6) Manipulator successfully picked up the bookcase.

While these points outline the specific benefits and qualities of CAPM, it is important to note a ultimate goal of this project. The CAPM Project will introduce robotics into the library and, perhaps more importantly, digital library context. As robotics have provided great impact and utility within manufacturing and, increasingly, computer-assisted surgery, it is possible that similar gains will be achieved in developing digital libraries. Already, some cultural heritage faculty and librarians have identified CAPM as the best option for digitizing the vast amounts of knowledge retained in print format. Additionally, through batch scanning, CAPM will produce automatically and systematically preserved copies of printed materials.

Future work includes the improvement of the robot navigation system, and the development of the page-turning robotic system for the next stage of the CAPM project.

Reference

- [1] Suthakorn, J., Lee, S., Zhou, Y., Thomas, R., Choudhury, S., Chirikjian, G.S., "A Robotic Library System for an Off-Site Shelving Facility," *Proceedings of the IEEE International Conference*

on Robotics and Automation (ICRA) 2002, Washington DC, May 2002.

- [2] Hansson R., "Industrial robot lends a hand in a Swedish library", *ABB Review*, No. 3, 1995, pp.16-18.
- [3] Safaric, R., Jezernik, K., Calkin D.W., Parkin, R.M., "Telerobot control via Internet," *Proceedings of the IEEE International Symposium on Industrial Electronics 1999*, Vol. 1, 1999. pp. 298-303.
- [4] Byrd, J.S., "ARIES: A Mobile Robot Inspector," *Proc. of ANS 6th Topical on Robotics & Remote Systems*, Monterey, CA, Feb. 1995.
- [5] <http://library.csun.edu/>
- [6] Suthakorn, J., "Paradigms for Service Robotics," *PhD Dissertation*, Department of Mechanical Engineering, The Johns Hopkins University, April 2003.