

# Design and Build of 1000 V Joule Thief Inverter by Utilizing Pineapple as an Energy Source

Wiwin A. Oktaviani<sup>1\*</sup>, Arrofi Lumban Gaol<sup>2</sup>

<sup>1,2</sup> Department of Electrical Engineering, Universitas Muhammadiyah Palembang, Palembang, Indonesia  
Email: <sup>1</sup> wiwin\_oktaviani@um-palembang.ac.id, <sup>2</sup> maulana.arrofi@gmail.com,

\*Corresponding Author

**Abstract**—The availability of fossil energy-based energy sources is currently depleting and cannot meet the increasing consumption. Therefore, the development of environmentally friendly alternative energy or known as green energy is increasingly being encouraged. One form of green energy that can be utilized, especially in the South Sumatra region, is pineapple. In this paper, the use of pineapple as a raw material for batteries is introduced. The material for making pineapple batteries will affect the amount of battery capacity produced. The pineapple battery capacity will then determine the amount of output voltage generated by the joule thief converter. Apart from the material, the voltage increase in the joule thief converter circuit is also influenced by the source voltage of the pineapple battery, the ferrite core step-up transformer, and the arrangement of the diodes and capacitors in the circuit. The pineapple battery capacity produced in this study is 1209 mAh, the maximum voltage is 4.63 V, the pineapple battery life is 1.0334 hours, and the charging process is 34 minutes. The resulting circuit in this study shows that the maximum output voltage of the joule thief converter is 1531 V, a current of 4.19 mA and the ability to increase the voltage to the source is 300 times.

**Keywords**—Voltage; Pineapple Battery; Joule Thief Converter Circuit

## I. INTRODUCTION

The availability of fossil energy sources is decreasing with the increase of mining to generate electrical energy. This condition triggers the use of non-fossil energy sources as an alternative energy source. Even today, the world energy program focuses on developing environmentally friendly alternative energy known as green energy [1].

Green energy is green energy that comes from natural sources such as solar energy, wind, rain, tides, plants, algae and geothermal energy. The electrical energy that comes from fruits or plants is a new type of energy known as bioelectricity. This energy is a breakthrough in providing alternative energy sources, especially for off-grid regions [28]. One of the green energies that can be utilized in Indonesia, can be found in fruits.

Electrical energy can be generated from fruits, mostly fruits which contain lots of citric acids (HNO<sub>3</sub>). Acids are of two types, namely strong acids and weak acids. A lot of strong acids will produce lots of ions; meanwhile, weak acids have fewer ions. The more acidic a solution is, the smaller the pH value, and vice versa. The more ions

produced so that the electric current produced is also more significant, and as a result, the conductivity of the electrolyte solution is also getting higher. Several types of fruits that have been studied for potential as an alternative energy source are mango [2,3] and citrus [4]. Apart from being used as a source of energy, biomass waste from fruit, such as jackfruit and durian, can be used to produce carbon airgel electrodes as a material for making ultracapacitor. The resulting ultracapacitor has excellent stability and charge cycles [5]. Several studies [18]. [19]. [20], [21], have also shown that activated carbon or porous carbon derived from fruit extracts can be used as a supercapacitor electrode material.

Lathika [6] processed banana waste by using Vermicomposting technique. This technique significantly increases the ionic content of banana waste so that it can be used as an electrolyte. One single compartment contains 200g of vermicompost mixed with 50ml of water producing a voltage of 1.6V. Meanwhile, the use of three isolated vermicompost compartments provides a capable voltage of 5.4V turn on the LED bulb. Orange peel waste combined with other fruit wastes, such as banana peels, processed using the D-limonene removal column technique and immobilized yeast fermentation, will increase the ethanol production 12 times [22]. It can be concluded that the potential for utilizing fruit as a source of energy processed with the right technology is promising. In fact, biomass from grapes, olives, and other fruit trees, can supply a large part of the total energy consumed for annual house heating in Andalusia [23].

This acid solution can be used as a bio-battery. The principle of bio-battery only involves the transportation of electrons between two electrodes separated by a conductive medium (electrolyte) which provides the power of electro-motion in the form of electric potential and current [4]. At the electrolyte electrode, the flowing electrons are carried by the ions and then undergo electrolysis. Electrolysis means the chemical changes that are produced by passing an electric current through an electrolyte. Electrons flow from the cathode through the electrolyte to the anode. The cathode is a positive electrode, as a copper plate, and the anode is a negative electrode, as a zinc plate. This process generates electricity in the same way as a voltaic battery. Lindstrom [7] stated that fruits and vegetables that contain acids could be used as an electrolyte solution. The average



voltages of various fruits in Lindstrom's study are presented in Table 1.

TABLE I AVERAGE VOLTAGE OF VARIOUS FRUITS [7]

No.	Fruit name	Average voltage (Volt)
1	Grape	0.93
2	Orange	0.89
3	Lemon	0.92
4	Kiwi	0.85
5	Tomato	0.62

Apart from fruit waste, it is used as bioethanol or biofuel through a fermentation process. It can also be used as an inexpensive raw material for Abiotic reducing sugar-air alkaline battery (SAAB) or fuel cell (SAFC) to generate electricity. The resulting battery has a coulomb efficiency characteristic of about 37% at 0.7–0.8 mW cm<sup>-2</sup> close to the peak power density [24].

One of the fruits which contain lots of acids is pineapple (*Ananas comosus* (L.) Merr.) [8]. The acids contained in pineapple is citric acid, malic acid, and acids oxalate. The most acid type dominant namely 78% of citric acid total acid [25]. Meanwhile, the magnitude of the voltage and current resulting from pineapple's acidic properties at pH 4 is 0.92 V and 1.839 mA, respectively [26]. This fruit is very much found in South Sumatra, such as in the city of pineapples, namely Prabumulih, Muara Enim, Lahat, Ogan Komerling Ilir and Ogan Ilir. This case study research took place in Senuro Village, Ogan Ilir Regency. The pineapple in Senuro Village is limited to being traded; there has not been any use of it as an alternative source of electrical energy [9].

The voltaic cells produced by pure pineapple fruit in this study were 0.6 - 0.7 V while the current was only 160  $\mu$ A, so it takes some mixed material to make it as battery electrolyte with long-lasting charge. The battery will be increased in voltage with a converter circuit up to 1000 V to be able to turn on fluorescent lamps and CFL lamps. This study aims to evaluate and analyze the pineapple battery capacity and evaluate the output voltage and the ability to increase the voltage of the joule thief converter.

## II. LITERATURE STUDIES

### A. Battery

The battery is an electrochemical cell that can convert chemical energy into electrical energy. The first time the battery was made by Alessandro Volta in 1800, because of that battery cells are often referred to as Volta cells. An archaeological discovery revealed that long before the Volta cell battery was made a Baghdad battery was found in Baghdad, Iraq. In 1836 the battery cell was then called the Daniell cell, which then caused battery production to increase very rapidly [10].

There are two types of battery cells, namely primary batteries and secondary batteries. The primary battery is a disposable battery cell, while the secondary battery is a battery cell designed to be recharged (rechargeable battery). A battery is composed of several Volta cells (can be more

than one Volta cell). Each Volta cell is composed of two and a half cells, namely cathodic cells and anodic cells, which are connected in series by an electrolyte containing anions and cations. In the Volta cell, there is a redox reaction, reduction-oxidation, namely the cations, are reduced at the cathode, while the anions are oxidized at the anode. The two electrodes, namely the cathode and the anode, are not connected directly to each other but are connected electrically through an electrolyte solution. A separator between half cells installed to prevent electrolyte mixing, but the ions between half cells can still pass through the separator [11].

If a battery is composed of two different metals, the metal with a more positive reduction potential will become the cathode. For example, suppose the battery is composed of zinc and iron. In that case, the iron will become a cathode, because zinc ions have a reduction potential of -0.76 V. In comparison, zinc has a standard reduction potential of -0.44 V. After all, zinc has a negative reduction potential, then it will act as a battery anode, meaning the zinc metal will be oxidized and the iron ions will be reduced. So that the half-cell reaction and the total reaction of the battery cell are as follows:

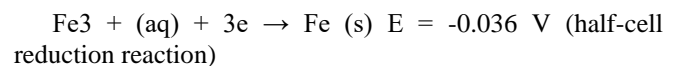
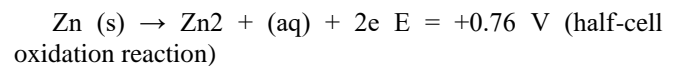

The cell voltage or voltage is (+0.76 + (-0.036) V = +0.724 V.

In other words, the cell's electromotive force is the result of changes in chemical energy through redox reactions. From this voltaic cell system, the electrical energy produced depends mainly on the type of solution and electrode, the type of material, and the modification of the electrode dimensions. Research by Fadli, [27] showed that the voltage value in the voltaic cell of pineapple is not influenced by the area of the electrode plate, the distance electrodes and the electrolyte solution's volume, thus allowing the voltaic cell dimensions to be made more compact / smaller.

On the other hand, corrosion of the electrodes caused by electrolyte can be avoided by coating the electrodes with a corrosion-resistant material. Research by Pauzi and Wicaksana [30] used seawater as the electrolyte fluid for voltaic cells so that silver or Ag were using as electroplating to protect the copper electrode from corrosion.

The capacity of a secondary battery is usually expressed in Ampere hours (Ah), which is the amount of electric current involved in the electrochemical reactions in the battery. This capacity parameter can be measured by measuring the current (A) during the usage process, based on equation (1).

$$Q = \int I \cdot dt \quad (1)$$

with,

Q = battery capacity (Ah)

I = current (A)

$t$  = battery usage time (hours)

The specific capacity of a battery is expressed in units of Ah.g-1, which is the capacity of the energy released by the battery per unit mass (g) of the active electrodes in the battery cell. This specific capacity is expressed in equation (2)

$$Q_{\text{specific}} = Q / W \quad (2)$$

with,

$Q_{\text{specific}}$  = specific capacity (Ah.g-1)

$Q$  = capacity (Ah)

$W$  = weight of active electrode (g)

In the battery nameplate, it is generally a Wh (Watt-hours) value. Wh (Watt-hours) is a unit of the amount of electrical energy consumption or electric power consumed by a load at a particular time (hours). The Wh value of a battery is obtained by multiplying the value of the electric power consumed by a quantity of time.

$$P_{\text{total}} = VQ \quad (3)$$

with,

$P_{\text{total}}$  = total power of a battery (Wh)

$V$  = voltage (Volt)

$Q$  = battery capacity (Ah)

The battery capacity can be calculated using equation (4) below :

$$Q = \int I . dt \quad (4)$$

with,

$I$  = current (A, mA)

$dt$  = time changing

**B. Joule Thief Circuits**

The Joule Thief circuit is a simple blocking transistor circuit that operates as an energy thief that can generate electrical energy when energy sources are very small [12]. Therefore, this electronic circuit can be used to increase the electric voltage many times over. Joule thief circuits are very much found in electronic equipment, for example in energy-saving lamps, power banks, remote controls, computer equipment, wall clocks, mosquito racket circuits and emergency lighting circuits. Even with the help of this circuit, it can reactivate the 1.5 V battery voltage so that it can be used again [13].

The key to this Joule Thief circuit is the transformer because the comparison of the number of primary and secondary windings will affect the performance of the Joule Thief circuit [14]. This study uses a transformer with the number of secondary windings multiplied from 100 turns to 5000 turns to produce a double voltage step up. The type of transformer used is a ferrite core transformer or a toroid transformer that produces high frequencies with low losses. The simple joule thief circuit consists of a 1.5 V battery, 1kΩ resistor, a ferrite or toroid core transformer, an NPN transistor and an LED lamp [13].

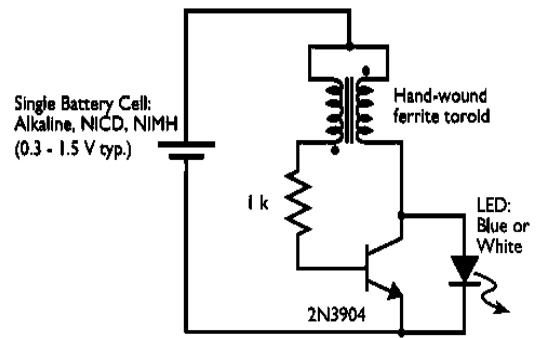

Fig. 1. Simple Joule Thief Circuit [13]

Besides increasing the voltage, using a joule thief circuit can also increase the current, as shown in [30]. The increase in current is proportional to the value of the voltage.

**C. Cockcroft-Voltage Multipliers**

Cockcroft-Walton multiplier is a type of voltage multiplier circuit which is an improvement over the circuit developed by Greinacher in 1932 to produce high-level DC voltages. The Cockcroft-Walton multiplier can increase the AC input voltage coming from the generator or transformer several times, depending on the number of rectifier diodes arranged in stages, the frequency and input voltage given [15].

As shown in Figure 2, there are two rows of capacitors in the generator. A high-frequency pulse generator will provide an AC voltage to the Cockcroft-Walton multiplier input through a high voltage transformer. In contrast, at the output, a DC voltage will be obtained, which is twice the input voltage. The capacitor on the right is called  $C_r$ ,  $C_r + 1$ ,  $C_r + 2$ . In contrast, the capacitor on the left is called  $C_l$ ,  $C_l + 1$ ,  $C_l + 2$ . Each left capacitor is connected to the right capacitor by a cross diode. The voltage across all capacitors is  $2 V_{\text{max}}$ , except for  $C_1$  where it is only  $V_{\text{max}}$ . The total output voltage is  $2nV_{\text{max}}$ , where  $n$  is the number of stages. Each stage consists of two capacitors and two high voltage diodes. Thus the use of multistage is structured in a way that is possible, in order to obtain very high voltages. When the Cockcroft-Walton multiplier is loaded, the output voltage never reaches  $2nV_{\text{max}}$  [16].

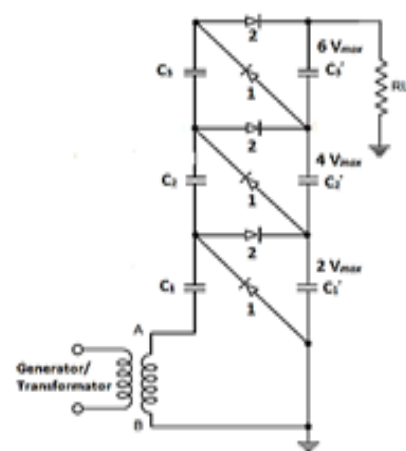

Fig. 2. Three-stage Cockcroft-Walton Multiplier circuit [15,16]

## III. RESEARCH METHOD

## A. Making a Battery

The pineapple fruit used is the third harvest fruit as much as 3-4 fruits with a weight of approximately 1500 grams. This choice is because these pineapples are small in size with a length of  $\pm 8$  cm and a width of 6 cm and they are generally not sold because they are not economically valuable. The pineapple used is perfectly ripe fruit—the ripe the fruit, the lower the acidity, which means that the pH increases. Increased fruit maturity impacts decreasing the value of fruit durability, which increases the concentration of mobile ions in the fruit [29]. The more ions that move, the better the electrical conductivity. Therefore, the level of ripeness of the pineapple that will be used must be considered. To make the mixture denser, use a paste from used batteries of approximately 500 grams. The two ingredients are mixed with about 300 ml of liquid caustic soda. So that the three ingredients are tied together, put it in the oven for approximately 5-6 hours until it is completely dry. The paste is then ground into a powder and then put into a container of zinc. Zinc serves as an anode. The cathode is made of the carbon rod. At this time, the battery cannot be used and must be stored in a closed space for up to one to three days, for the paste and electrodes to act (redox).

The electrodes used in the pineapple battery are 5.8 cm long carbon rod and 5.4 cm long zinc. Each has a resistance value of  $4.6 \Omega$  and totals 18 pieces.

One pineapple battery cell has a voltage of 1.367 V, and a current of 0.16 A. Pineapple battery was made of 18 cells with the aim that the voltage and current can be used as a source of electrical energy to activate the joule thief converter and turn on the lamp. From the 18 cell pineapple battery produces a voltage of 4.63 Volt and a current of 1.08 Amperes.

## B. Battery Performance Testing

The current and voltage measurements are taken in order to see the performance of the battery when the battery is not fully charged or fully charged in several conditions:

1. The battery is not connected to the Joule Thief circuit
2. The battery is connected to the Joule Thief circuit
3. The battery is connected to the Joule Thief circuit and a load of CFL lamps (5W, 18 W and 25 W) and fluorescent lamps (5W, 10W and 20 W).

The Joule Thief circuit is shown in Fig. 3.

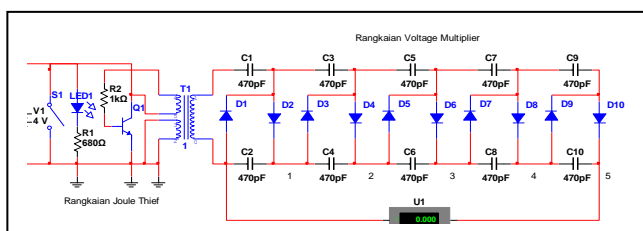

Fig. 3. Joule Thief and Voltage Multiplier Circuit

## IV. RESULT AND DISCUSSION

Table 2 shows the voltage and current measurement values for pineapple batteries, the joule thief circuit and when the battery and joule thief series are loaded. Voltage measurements were carried out ten times, while the current and frequency of the Joule thief circuit were measured five times.

TABLE II. AVERAGE VALUES OF VOLTAGE, CURRENT AND FREQUENCY MEASUREMENTS

No.	Parameter	Full charge
		Average value
1	$V_{\text{battery}}$	4,513V
2	$I_{\text{battery}}$	1.17A
3	$V_{\text{out}}$	1487.1 V
4	$I'_{\text{m out}}$	4,142 mA
5	$V_{\text{load CFL 5W}}$	227.33 V
6	$I_{\text{load CFL 5W}}$	0.09 mA
7	$V_{\text{load CFL 18W}}$	359.167 V
8	$I_{\text{load 18W CFL}}$	0.12 mA
9	$V_{\text{load CFL 25W}}$	301.5 V
10	$I_{\text{load CFL 25 W}}$	0.15 mA
11	$V_{\text{load Fluorescent 5W}}$	228,833 V
12	$I_{\text{load Fluorescent 5W}}$	0.75 mA
13	$V_{\text{load Fluorescent 10W}}$	214 V
14	$I_{\text{load Fluorescent 10W}}$	0.78 mA
15	$V_{\text{load Fluorescent 20W}}$	251 V
16	$I_{\text{load Fluorescent 20W}}$	0.68 mA

Pineapple battery (*rechargeable battery ananas*) is composed of a positive pole in the form of rods of carbon (*carbon rod*). The rod is surrounded by a mix of shredded pineapple fruit pulp and mixed with a paste of used batteries consisting of the elements manganese dioxide and carbon powder. In contrast, the negative pole is zinc metal, which also functions as a *container*. While the electrolyte used is from liquid *caustic soda* (NaOH) so that the reaction takes place in an alkaline atmosphere.

The calculation of potential total cell [10]:

Cathode:

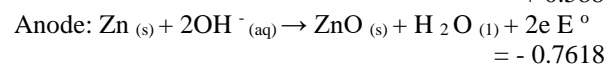
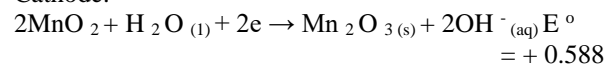

$$\begin{aligned} E_{\text{cell}} &= E_{\text{cathode}} - E_{\text{anode}} \\ &= 0.588 \text{ V} - (-0.7618 \text{ V}) \\ &= 0.588 \text{ V} + 0.7618 \text{ V} \\ &= 1.3498 \text{ V} \end{aligned}$$

The calculation results show that the electrodes strongly influence the voltage and current of the pineapple battery in the form of *carbon rods* and zinc as well as the supporting electrolytes.

Cycle capability is the ability of the stability of the materials making up the battery during *charge-discharge*. Cycle capability can be calculated from the number of charge-discharge cycles to capacity, Q (Ah), of the battery down to 20% of its initial capacity. Table 3 shows the pineapple battery charger specifications.

TABLE 3. PINEAPPLE BATTERY CHARGER SPECIFICATIONS

No.	Parameter	Value
1	AC $V_{in}$	100-240 V
2	Frequency	50-60 Hz
3	$I_{in}$	65 mA
4	$V_{out}$	5 V
5	$I_{out}$	350 mA

Fig. 4 shows the amount of current and voltage for the battery to be charged.

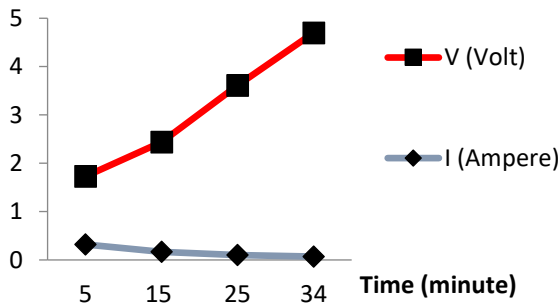

Fig. 4. Changes in current and voltage values during the charging process of pineapple batteries

Charging time until the battery is full charge is relatively fast, which is 34 minute due to the electrolyte content in the form of liquid caustic soda (NaOH) or sodium hydroxide [17]. The NaOH interacts with the sodium and citric acid content in [8]. Besides, this battery also can cycle to charge the battery itself, when the battery is in a state of discharge or is finished discharging. The ability of the charging cycle itself causes the charging process to be faster. This ability is an advantage of this pineapple battery. Fig. 5 shows a graph of the self-charging circulation of a pineapple battery.

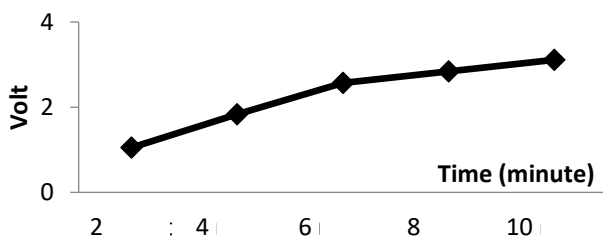

Fig. 5. Graph of self-charging circulation in pineapple battery

Liquid caustic soda (NaOH) is one of the basic ingredients for making hard soap which has strong alkaline electrolyte properties [17]. When the charge in the battery is empty, the liquid caustic soda (NaOH) will form a bubble of gas. Then interact with citric acid and sodium and the fibres contained on pineapple fruit and the content of used battery paste in the form of manganese dioxide and carbon, so the charge in the battery can return [8]. The charge-discharge process or the cyclability of the cycle is very dependent on the stability of the materials that make up the battery [11].

Fig. 6 shows the change in voltage duration of use (discharging) the battery pineapple in a condition linked to a series of Joule Thief converter and a load of the lamps Compact Fluorescent Light Bulb (CFL) of 25 W is for 1 hour 2 minutes. The remaining voltage of the pineapple battery is 1.051 V, and the current is 0.23 A.

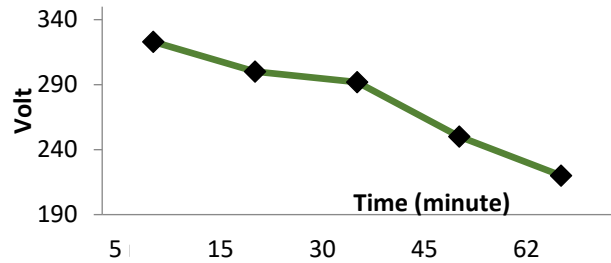

Fig. 6. Usage data graph (discharging) battery pineapple with connected at 25 W CFL bulbs

Battery capacity is the amount of electric current involved in electrochemical reactions in a battery and is expressed in Ampere hours (Ah). With the average current of a pineapple battery in a fully charged condition of 1.17 A (based on table 2) and a maximum usage time of 62 minutes (figure 10), the battery capacity calculated by equation (4) is:

$$\begin{aligned}
 Q &= \int I. dt \\
 &= 1.17 A \times 1.0334 \text{ jam} \\
 &= 1.209 Ah \\
 &= 1209 mAh
 \end{aligned}$$

Fig. 7 shows the measurement of the 18 cell battery voltage with a full charge battery condition. The maximum voltage is 4.63 V, and the minimum voltage is 4.37 V. While Fig. 8 Shows the current measurement of 18 cell batteries with a full charge battery condition, with a maximum value of 1.27 A and a minimum value of 1.08 A.

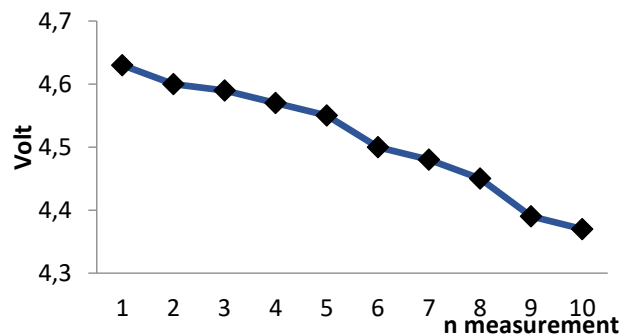

Fig. 7. Battery voltage measurement of 18 cell battery in full-charge condition



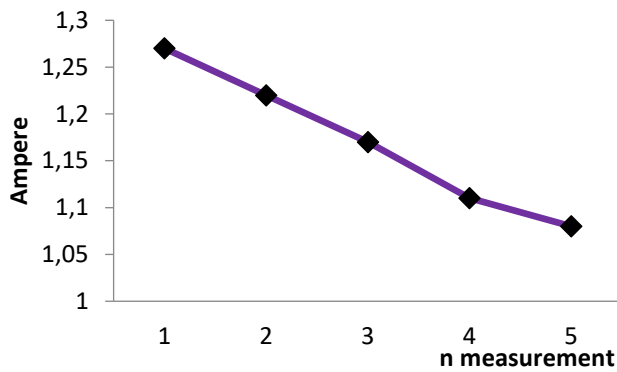

Fig. 8. Graph of current measurement data for 18 cell battery in full-charge condition

To see the performance of the Joule Thief converter circuit connected to a full charge pineapple battery, the output voltage and current are 10 and 5 times the measurement. The measurement results are shown in Fig. 9.

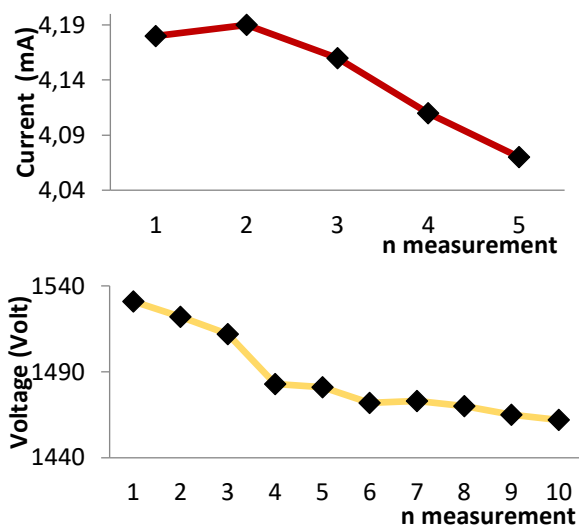

Fig. 9. The output voltage and current of the joule thief converter circuit is in a full charge pineapple battery state

The maximum voltage of 1531 V and a minimum value of 1462 V. While the value of the current has a range of 4.07 mA - 4.19 mA. The value of the maximum power that can be generated is the product of voltage and current to a maximum of 6.414 W. Frequency of circuit *joule thief converter* in a state of pineapple battery *full charge* has a maximum value of 29.29 kHz, and a minimum value of 29.18 kHz, Fig. 10.

Therefore, the ability to increase the voltage of the *joule thief converter* to the voltage of the pineapple battery is:

$$\begin{aligned} n &= V_{out} / V_{in} \\ &= 1531 \text{ V} / 4.63 \text{ V} \\ &= 330 / 1 \end{aligned}$$

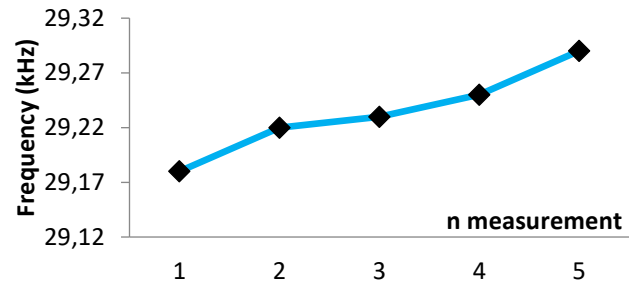

Fig. 10. Frequency data of the joule thief converter in a full charge pineapple battery

The output power of the joule thief converter is 6.414 W, capable of supplying 5 W CFL, 18 W CFL, 25 W CFL lamps and the lights are super bright. This condition due to:

- The CFL lamps work with electronic ballasts. However, the performance of the electronic ballast was replaced by a Joule Thief converter circuit. The starting method given by the Joule Thief converter to CFL lamps is the instant-start method. This instant-start method is to provide a very high initial voltage of 1531 V<sub>DC</sub> to discharge between the unheated electrodes.
- In addition to the initial voltage value that can make the CFL lamp turn on, another thing that affects it is the high frequency that comes from the Joule Thief converter, which is 29.29 kHz. This frequency has passed and is sufficient for the frequency standard required for this CFL lamp to light up, which is more than 20 kHz. The components that can generate high frequencies are from the ferrite core transformer used in the Joule Thief circuit.

Meanwhile, if the load is a lamp fluorescent 5 W, 10 W and 20 W, the light is in a state not too bright due to the current supply value of the Joule Thief converter is around 4 mA. However, the lights did not experience flicker. This result indicates that the output signal produced by the Joule Thief converter is in good condition without ripple or noise.

## V. CONCLUSION

A Joule Thief series connected to a pineapple battery is presented in this paper. The capacity of pineapple battery is equal to 1209 mAh, with a maximum voltage of 4,63 Volt. Joule Thief converter has a voltage output of 1462 Volt and a maximum voltage of 1531 Volt as well as the average voltage of 1487,1 Volt. The ability of the Joule Thief converter circuit to increase the pineapple battery voltage is 300 times. The pineapple battery, with its Joule Thief circuit, is more suitable for loads that do not require a large supply of current, such as CFL lamps. Pineapple battery usage time can reach 62 minutes for a load of 1 25 W CFL lamp.

## REFERENCES

- L. Anderloni and A. Tanda, "Green Energy Companies: Stock Performance and IPO Returns," *Research in International Business and Finance*, vol. 39, Part A, pp. 546-552, 2017.
- R. T. As Sadad and Iswanto, "Implementasi Buah Mangga Sebagai Tenaga," *Prosiding Seminar Nasional Aplikasi Sains & Teknologi (SNAST) Periode III*, hal. 56-62, 2012.

- [3] I. Azmi, "Prototipe Baterai Dari Buah Belimbing Sayur Sebagai Energi Alternatif. *Jurnal Ilmiah Pendidikan Fisika "Lensa"*, vol. III, no. 2, pp. 294-296, 2015.
- [4] F. Fallanaj, A. Ippolito, A. Ligorio, F. Garganese, C. Zavanella, and S. M. Sanzani, "Electrolyzed Sodium Bicarbonate Inhibits *Penicillium Digitatum* and Induces Defence Response Against Mould in Citrus Fruit," *Postharvest Biology and Technology*, vol. 115, pp. 18-29, 2016.
- [5] K. Lee, L. Shabnam, S. N. Faisal, V. C. Hoang, and V. G. Gomes, "Aerogel from fruit biowaste produces ultracapacitors with high energy density and stability," *Journal of Energy Storage*, vol. 27, p. 101152, 2020. <https://doi.org/10.1016/j.est.2019.101152>
- [6] M. Lathika, and L. Prabha, "Generation of Electric Potential from Vermicomposted Fruit Waste," *International Journal of Research in Environmental Science*, vol. 3, no. 1, 2017. <https://doi.org/10.20431/2454-9444.0301005>
- [7] E. Lindstrom and M. Godric, *The Electric Fruits*, 2009.
- [8] Irfandi, Karakterisasi Morfologi Lima Populasi Nanas (*Ananas comosus* L. Merr), *Skripsi*, 2005.
- [9] S. S. Oncel, "Green Energy Engineering: Opening a Green Way for the Future," *Journal of Cleaner Production*, vol. 142, Part. 4, pp. 3095-3100, 2017.
- [10] F. Rahmawati, *Elektrokimia Transformasi Energi Kimia-Listrik* (1st ed.), Surakarta, Indonesia: Graha Ilmu, 2013
- [11] D. Linden, and T. B. Reddy, *Handbook of Batteries*. USA: McGraw-Hill, 2002.
- [12] Haidar, Sajjad, 2015, MOSFET-based Joule Thief steps up voltage, February 23, 2015, EDN Network
- [13] P. J. Kelly, *Practical Guide to Free Energy Devices*, America: eBook Free Energy, 2016
- [14] E. N. Budisusila, and B. Arifin, "Joule-Thief Circuit Performance for Electricity Energy Saving of Emergency Lamps," *Proceeding of the Electrical Engineering Computer Science and Informatics*, vol. 3, no. 1, p. 012017, 2016. <https://doi.org/10.11591/eecs.v3.1152>
- [15] Waluyo, Syahrial, Nugraha, S., and Permana, Y. "Rancangan Awal Prototipe Miniatur Pembangkit Tegangan Tinggi Searah Tiga Tingkat dengan Modifikasi Rangkaian Pengali Cockroft-Walton," *Seminar Nasional ke 9 Rekayasa Teknologi Industri dan Informasi*, pp. 137-141, Bandung: Institut Teknologi Nasional Bandung, 2014.
- [16] C. Wadhwa, *High Voltage Engineering* (2nd ed.), New Delhi: New Age International Publishers, 2007
- [17] A. Guerfi, J. Trottier, C. Gagnon, F. Barry, and K. Zaghbi, "High Rechargeable Sodium Metal-Conducting Polymer Batteries," *Journal of Power Sources*, vol. 335, pp. 131-137, 2016.
- [18] H. Azhan, K. Azman, O. H. Hassan, N. Osman, R. Abd-Shukur, M. Deraman, W. Kong, M.K. Halimah, R. S. Azis, M. R. Sahar, Z. Aspanut, S. A. Halim, "Review of Energy and Power of Supercapacitor Using Carbon Electrodes from Fibers of Oil Palm Fruit Bunches," *Materials Science Forum*, vol. 846, pp. 497-504, 2016. <https://doi.org/10.4028/www.scientific.net/MSF.846.497>
- [19] M. Vinayagam, R. Suresh Babu, A. Sivasamy, and A. L. Ferreira de Barros, "Biomass-derived porous activated carbon from *Syzygium cumini* fruit shells and *Chrysopogon zizanioides* roots for high-energy density symmetric supercapacitors," *Biomass and Bioenergy*, vol. 143, p. 105838, 2020. <https://doi.org/10.1016/j.biombioe.2020.105838>
- [20] T. R. Kumar, R. A. Senthil, Z. Pan, J. Pan, and Y. Sun, "A tubular-like porous carbon derived from waste American poplar fruit as advanced electrode material for high-performance supercapacitor," *Journal of Energy Storage*, vol. 32, p. 101903, 2020. <https://doi.org/10.1016/j.est.2020.101903>
- [21] E. Taer, A. Apriwandi, R. Taslim, A. Agutino, and D. A. Yusra, "Conversion *Syzygium oleana* leaves biomass waste to porous activated carbon nanosheet for boosting supercapacitor performances," *Journal of Materials Research and Technology*, vol. 9, no. 6, 13332-13340, 2020. <https://doi.org/10.1016/j.jmrt.2020.09.049>
- [22] I. S. Choi, Y. G. Lee, S. K. Khanal, B. J. Park, and H.-J. Bae, "A low-energy, cost-effective approach to fruit and citrus peel waste processing for bioethanol production," *Applied Energy*, vol. 140, pp. 65-74, 2015. <https://doi.org/10.1016/j.apenergy.2014.11.070>
- [23] J. M. Rosúa, and M. Pasadas, "Biomass potential in Andalusia, from grapevines, olives, fruit trees and poplar, for providing heating in homes," *Renewable and Sustainable Energy Reviews*, vol. 16, no. 6, pp. 4190-4195, 2012. <https://doi.org/10.1016/j.rser.2012.02.035>
- [24] M. Provera, Z. Han, B. Y. Liaw, and W. W. Su, "Communication—Electrochemical Power Generation from Culled Papaya Fruits," *Journal of The Electrochemical Society*, vol. 163, no. 7, pp. A1457-A1459, 2016. <https://doi.org/10.1149/2.0051608jes>
- [25] Irfandi, "Karakterisasi Morfologi Lima Populasi Nanas (*Ananas Comosus* (L.) Merr.)," Thesis, IPB (Bogor Agricultural University), 2005. <http://repository.ipb.ac.id/handle/123456789/12566>
- [26] A. Atina, "Tegangan Dan Kuat Arus Listrik Dari Sifat Asam Buah," *Sainmatika: Jurnal Ilmiah Matematika Dan Ilmu Pengetahuan Alam*, vol. 12, no. 2, Article 2, 2015. <https://doi.org/10.31851/sainmatika.v12i2.989>
- [27] U. M. Fadli, B. Legowo, and B. Purnama, "Demonstrasi Sel Volta Buah Nanas (*Ananas Comosus* L. Merr.)," *Indonesian Journal of Applied Physics*, vol. 2, no. 2, pp. 176-182, 2012
- [28] K. A. Khan, L. Hassan, A. K. M. Obaydullah, S. M. A. Islam, M. A. Mamun, T. Akter, M. Hasan, Md. S. Alam, M. Ibrahim, M. M. Rahman, and M. Shahjahan, "Bioelectricity: A new approach to provide the electrical power from vegetative and fruits at off-grid region," *Microsystem Technologies*, vol. 26, no. 10, pp. 3161-3172, 2020. <https://doi.org/10.1007/s00542-018-3808-3>
- [29] J. Juansah, I. W. Budiastra, K. Dahlan, and K. B. Seminar, "Electrical Properties of Garut Citrus Fruits at Low Alternating Current Signal and its Correlation with Physicochemical Properties During Maturation," *International Journal of Food Properties*, vol. 17, no. 7, pp. 1498-1517, 2014
- [30] A. G. Pauzi, and B. Wicaksana, "Analisis Pemanfaatan Joule Thief Tipe Toroida Pada Sel Volta Menggunakan Elektroda (Cu(Ag)-Zn) Berbahan Elektrolit," *Jurnal Fisika Indonesia*, vol. 24, no. 1, pp. 7-10, 2020. <https://doi.org/10.22146/jfi.v24i1.51858>