

Optoelectronic mixer with photoconductive switch for 1550 nm wavelengths

Róbert Horváth, Jean-François Roux, Julien Poëtte and Béatrice Cabon

Abstract—We demonstrate an optoelectronic mixer based on an ultrafast InGaAs photoconductive switch and its use in an innovative heterodyne detection system for Radio over Fibre transmission. The advantage of the proposed switch is its relatively flat response curve in a wide frequency range up to 67 GHz. Two mixing schemes are presented through I-Q modulated data-stream down-conversion. The data can modulate either the electrical signal or the optical signal. In case the electrical signal is modulated, a mode-locked semiconductor laser diode is used as an optical local oscillator at the self-oscillating frequency of 24.5 GHz. The InP based quantum-dash mode-locked laser emitting in the 1570 nm wavelength range is stabilized by a feedback loop and shows a low phase noise in order to increase the mixing performances of the detection apparatus. In a second experiment, the photoconductive switch is combined with a continuous wave laser to demonstrate the feasibility of down converting an optically provided data-stream with an electrical local oscillator.

Index Terms— heterodyne mixing, millimetre-wave receiver, mode-locked laser, optoelectronic mixer, photoconductive switch, radio over fibre.

I. INTRODUCTION

Telecommunication systems nowadays are increasingly moving towards photonic solutions due to the advantage of high bandwidth and low losses, along with the easy integration with fibre-based networks. Microwave Photonics (MWP) is the interdisciplinary field giving the technology for the most advanced systems. Radio over fibre (RoF) networks are one of the beneficiaries of MWP. In the wireless link of a RoF network, millimetre-wave (mmW) generation with photonic solutions is already proved to be suitable for systems operating in the millimetre-wave range [1]. Optoelectronic mixers can also take advantage of the photonic MMW generation and can be used at the receiver side of the RoF networks. Usually, the downconversion of received signals is performed with an electronic mixer with electronic radio frequency (RF) local oscillators. In this paper, we propose an original optoelectronic system utilizing a wide bandwidth photoconductive switch (PSW) as an optoelectronic mixer. The system is working in the 1550-1570 nm wavelength range, making it compatible with telecommunication networks. Even if photomixers are frequently used for THz generation and detection [2], few demonstrations of their use at RF frequencies for telecommunications experiment have been published. In a

This project has received funding from the European Union’s Horizon 2020 research and innovation programme under the Marie Skłodowska-Curie grant agreement No. 642355 FiWiN5G.

previous research, an InGaAs PSW based optoelectronic mixer was already investigated [3]. Because of the rather large photocarrier-lifetime of the simple InGaAs semiconductor the results showed only 20 GHz electrical bandwidth, and 300 MHz optical bandwidth. Here, the ultra-fast response time of the used photoswitch in our system results in a much larger optical and RF bandwidth, potentially above 100 GHz. The system is also taking advantage of the high-stability of an InP based semiconductor mode-locked laser (MLL) with optical feedback. Together these components give a simple and robust optoelectronic mixer for mmW applications. In a first setup, the local oscillator is optically provided using a semiconductor MLL or an externally modulated continuous wave (CW) distributed feedback (DFB) laser. The RF signal at the input of the mixer is carrying the data. This first scheme, named as Setup-I, is illustrated in Fig.1. A second setup, named Setup-II, is using an electrical local oscillator provided by an RF synthesizer. The optical signal is coming from a laser source which output is modulated by a RoF signal (carrying the data) thanks to an external electro-optic modulator. Fig. 1. is also illustrating this second setup.

In the next Section we are introducing the photoconductive switch, the MLL stabilization setup and the CW DFB laser. Section III and IV are explaining the two optoelectronic mixer schemes through data-stream downconversion and demodulation experiment. A conclusion is given in Section V.

II. MIXER COMPONENTS

A. Photoconductive switch

The proposed system uses a PSW as the optoelectronic mixer element. The switch schematic view is illustrated in

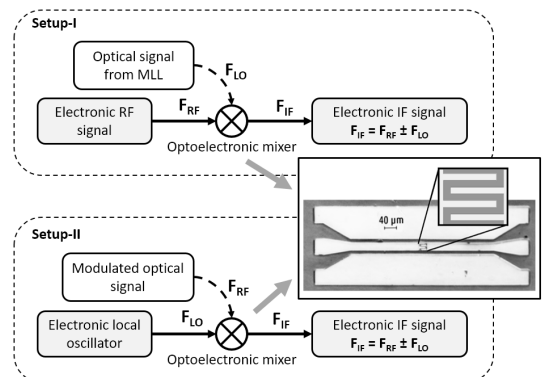

Fig. 1. The two optoelectronic mixing schemes with a photoconductive switch as a hybrid mixing device. Inset: schematics of the switch

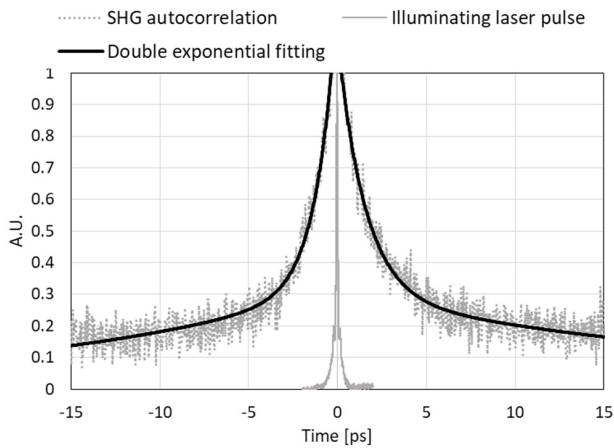

Fig. 2. Optical pulse response of the photoconductive switch (dotted grey) with the double exponential fitting (black). Continuous grey illustrates the incident ultrashort laser pulse for the measurement

the inset of Fig.1. The device samples are provided by the Ultrafast Photonics Group at University College London (UCL). Characterization of the samples has been performed previously at UCL in [4] and also by our group in [5].

The device consists of a coplanar waveguide (CPW) based on InP substrate. Both ends of the CPW are designed for coplanar RF-probe connection for easy manipulation. The centre conductor of the waveguide is interrupted with an etched InGaAs mesa in the middle. On top of this mesa an interdigitated electrode structure is deposited (magnified view in the inset of Fig.1.). The device is nitrogen-ion implanted in order to create a large number of defects in the InGaAs semiconductor material. These defects are ensuring the ultra-fast recombination time of generated photocarriers under 1550-1570 nm wavelength laser illumination.

The characterization in [5] showed an ultrafast response time of 1.2 ps for the switch, using an optoelectronic autocorrelation experiment [6]. The measurement was performed with short 90 fs long optical pulses centred at the wavelength of 1550 nm. The photoswitch response curve is illustrated on Fig. 2 including the optical pulse (in continuous grey) and the dual exponential fitting (in black) with the equation of $A \cdot e^{-t/T1} + B \cdot e^{-t/T2}$. The best fit was obtained for $T1 = 1.2$ ps and $T2 = 20$ ps and $A = 0.6$ and $B = 0.2$. We note that the contribution of the long 20 ps is low and that the main response of the device is ruled by the fastest constant time. We also measured that the device has a good dark resistance of 6 kΩ and a low equivalent capacitance of 5.7 fF. This picosecond response time is due to the large number of defects and it is insuring an optoelectronic cut-off frequency of the photoconductive device above 100 GHz. In [5], we also demonstrated its ultrawide electrical bandwidth with a relatively flat response curve over the 10-67 GHz range when the device is used as a mixer in between an RF signal and an optical local oscillator produced by a self-oscillating MLL. This wide bandwidth is a significant advantage for optoelectronic mixing applications, it allows the use of a wide range of frequencies and large signal bandwidths for high-speed communication.

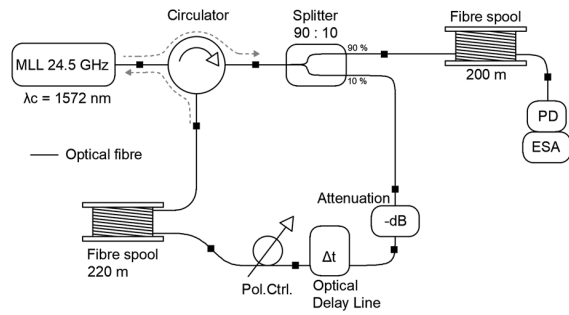

Fig. 3. Setup of the all-optical feedback loop for the MLL stabilization. PD: Photodiode; ESA: Electrical Spectrum Analyzer; MLL: Mode-locked laser.

B. Mode-locked Laser

In optoelectronic mixers, the local oscillator frequency is usually provided by an optical source modulated by an external device such as an electro-optic Mach Zehnder modulator (EO-MZM). In our system (setup- I) we are using a semiconductor InP based quantum-dash mode-locked laser as a source of the optical signal which allows to get rid of the external modulator, the chip-on-a-carrier is bonded to a microstrip line for the biasing electrical probe connection. The laser is provided by III-V Lab, Palaiseau, France. At a room temperature of 25°C and with 140 mA bias current the emitted central wavelength is around 1572 nm. The output optical signal contains 40 equally spaced modes in 8 nm bandwidth. The mode separation ~0.2 nm and corresponds to a self-oscillation frequency of 24.5 GHz. The output of the laser was couple into a single-mode standard SMF-28 fibre thanks to a coupler lens. To prevent disrupting back-reflections to the laser we used a fibre circulator after the pigtailed lens, the measured optical power at the circulator output is 8 dBm. In order to compensate for the intrinsic dispersion of the laser diode, 200 meters of SMF-28 fibre is used at output of the setup.

MLLs are known to provide a stable, low jitter pulse train with a linewidth in the 10-100 kHz range. We measured a free-running linewidth of 36 kHz. As the linewidth of the local oscillator in mixers is a crucial property regarding its performance, large linewidths can drastically corrupt the mixed signal quality. It is possible to improve the MLL stability with external manipulations: here we used a simple

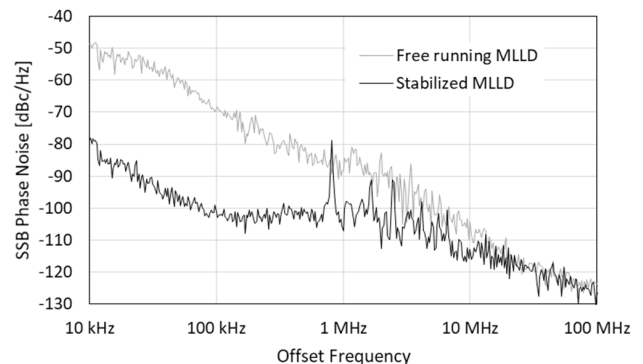

Fig. 4. SSB Phase noise curves for the free running and the stabilized MLL

Optoelectronic mixer with photoconductive switch for 1550 nm wavelengths

optical feedback loop, as proposed in [7]. The long optical fibre based feedback adds a long delay time and acts as a high-Q external cavity added to the laser. The setup of the stabilization feedback can be seen on Fig. 3. A part of the laser signal is injected back into the MLL cavity thanks to a fibre based circulator. The loop also contains a polarization controller to adjust the polarization of the injected signal to correspond to the laser signal polarization. An attenuator was used to adjust the feedback signal power. A variable optical delay line was used to control with picosecond precision the feedback delay. We found that feedback attenuation of around 28 dB is sufficient for optimal stabilization. Higher feedback power results in a “chaotic” behaviour of the MLL, while lower feedback power gives a lower level of stabilization. The optical signal’s average power at the output of the setup was measured to be 7 dBm.

We measured the single side-band phase noise of the fundamental beating signal for the free running and stabilized MLL with an Electrical Spectrum Analyser (ESA), the results are showed in Fig. 4. The stabilization resulted in a linewidth reduction of the beating signal below 1 kHz while the phase noise curve also showed a decrease of 30 dB, down to -100 dBc/Hz at 100 kHz offset frequency. The observed spurious peaks at 820 kHz and at its harmonics on the curve of the stabilized laser are corresponding to the free-spectral range (FSR) of the feedback loop, which has 220 meters of fibre in our case. Their power level in the RF spectrum are more than 20 dB below the main peak, which means their contribution is not too significant. It is important to note that mode-locked lasers are generating beating signals also at the harmonics of the fundamental tone, in this case at 49 GHz, 73.5 GHz and so on. The power level is similar for the first harmonics and the fundamental signal. In our experiments, only the fundamental beating signal will be involved in the mixing process.

In conclusion, such a feedback loop greatly enhances the

phase noise of the laser and this stabilized laser source with a 24.5 GHz beating fundamental frequency will provide a high quality local oscillator for down-conversion experiment.

C. Distributed feedback laser

In the first proposed scheme (Setup-I) and in the second proposed experiment (Setup-II) we also used a DFB laser that emits a continuous wave signal at 1551 nm. The optical power is maximum 10 dBm. The laser signal is intensity modulated by a Mach-Zehnder modulator (MZM) biased at its quadrature point. Due to the losses introduced by the modulator, at its output we measured an average power equal to 3 dBm. This modulated signal is used as the local oscillator or the data modulated signal in the following setups.

III. OPTOELECTRONIC MIXING – SETUP I

In the previous sections we introduced the two elements of the proposed optoelectronic mixer used in Setup-I: an ultrafast PSW with wide bandwidth, and an MLL with an external feedback loop providing a stable signal at 24.5 GHz with 7 dBm optical power. In a simple mixing experiment the system showed 72 dB mixing conversion loss in the 10-67 GHz range [5]. Despite this high level of losses, we note that this level is 8 dB better performance than the conversion loss of an unbiased Uni-Traveling Carrier photodiodes (UTC-PD) used as optoelectronic mixers [8].

In this section, the capabilities of our system used as a heterodyne detection stage is demonstrated with a data-stream downconversion and demodulation experiment. This detection apparatus can be used in the wireless receiver of a Radio over Fibre network. Where the received high frequency wireless signal containing the data, can be downconverted for signal processing. We first compare the performance obtained using the free running and the stabilized MLL. In a second step, we performed the experiment where the local oscillator frequency is provided by a different mmW generation solution: an intensity modulated CW laser source, a DFB laser modulated by an

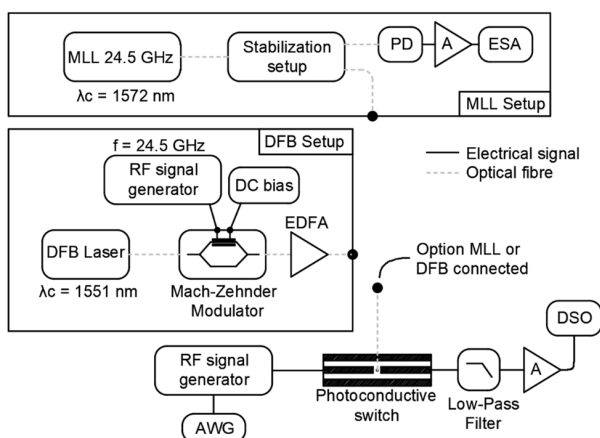

Fig. 5. Setup-I: Schematics of the heterodyne mixing experiment with data-stream modulated RF input signal and two cases of optical local oscillator. MLL: Mode-Locked Laser; DFB: Distributed Feedback Laser; EDFA: Erbium Doped Fibre Amplifier; PD: Photodiode; ESA: Electrical Spectrum Analyser; AWG: Arbitrary Waveform Generator; DSO: Digital Sampling Oscilloscope

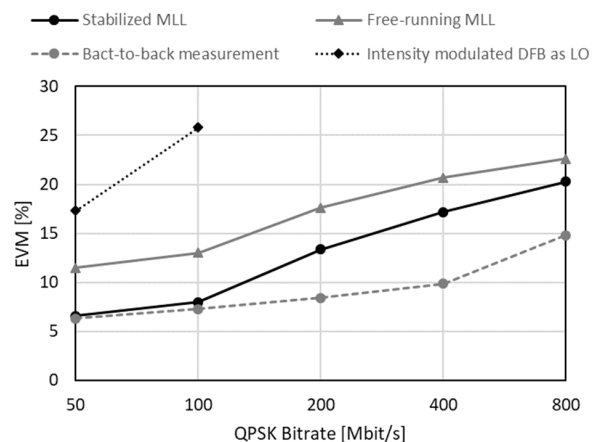

Fig. 6. Setup-I results. Measured Error Vector magnitude values versus the applied bitrate of the data-stream.

external MZM modulator with the same frequency of 24.5 GHz. The two configurations of the heterodyne stage are illustrated in Fig. 5. As the input of the PSW we used a signal from an RF signal generator having a 20 GHz carrier signal modulated by quadrature phase shift keying (QPSK) modulated data with different data-rates (50-100-200-400-800 Mbit/s). The I and Q of the modulated signal were generated by an Arbitrary Waveform generator (AWG) which outputs are directly connected to the wideband I-Q modulation inputs of a signal generator. The electrical carrier signal was added by this signal generator.

At the output of the photoconductive switch and after 38 dB amplifier, we analysed the mixed signal at the intermediate frequency (IF) of 4.55 GHz with a Digital Sampling Oscilloscope (DSO). The laser signals are guided to the photoswitch through standard single mode optical fibres to illuminate the InGaAs mesa with a bare-end pigtailed fibre. As mentioned above, the MLL had an output optical power of 7 dBm. Due to the modulator losses the DFB laser requires an Erbium Doped Fibre Amplifier (EDFA) to reach the same optical power as in case of the MLL. However, using this power level for the DFB setup (7 dBm), the DSO was unable to demodulate the IF signal, so we further amplified the DFB setup's output optical power up to 17 dBm, in order to increase the IF power level.

The DSO's built-in software was capable of online demodulating the received signal. The systems and their mixing performances are compared through the analysis of the Error Vector Magnitude (EVM). The results are illustrated in Fig. 6. The dashed line shows a reference back-to-back measurement, where we directly connected the signal generator to the DSO with a carrier frequency of 4.55 GHz. The continuous grey line shows the results obtained with the free-running MLL source used as the local oscillator while the continuous black curve corresponds to the results obtained with the stabilized MLL source. We can observe a reduction of 3 points on average of the EVM values for the stabilized source compared to the free running case, which shows the higher performances of the stabilized MLL. However, the difference is decreasing for higher bitrates, indicating that the setup is limited not only by the phase noise of the local oscillator, but possibly by the impedance matching of the equipment and the photoswitch. The dotted black curve shows the performance obtained with the amplified DFB laser. We can observe an increase of

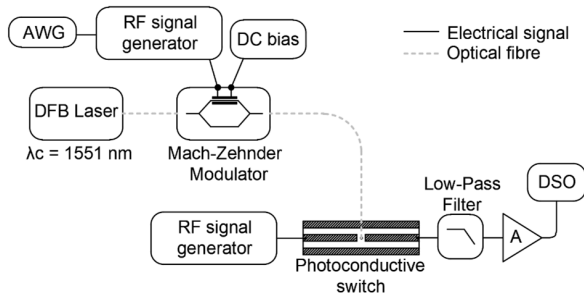

Fig. 7. Setup-II: schematics with intensity modulated DFB laser by a data-stream with electrical local oscillator.

17 points of the EVM, up to 25.8 %, for the case of 100 Mbit/s data-rate compared to the stabilized MLL. Above 100 Mbit/s the signal to noise ratio (SNR) of the IF signal was too low for the demodulation using the DFB setup as local oscillator. These results show the advantage of the stabilized MLL used as the local oscillator over the intensity modulated continuous wave laser source.

In the case of using the DFB, the modulation depth of the laser is very low compared to the MLL case, due to the sinusoidal shape of the modulator transfer function, compared to the ultrashort pulses of the MLL. This induces higher level of continuous emission because of the limited MZM modulating power in order to stay in the linear regime. These CW contributions in the system are unused power, which results in a lower RF power and consequently a lower IF power at the mixer output. Other degradations of the signal result from the added noise level due to the use of the EDFA.

This optoelectronic mixer scheme has the advantage of a simple setup, the mixer device is a passive component, active elements are only the optical and electrical sources generating the signal to be mixed, and the electrical amplifier of the IF signal.

IV. OPTOELECTRONIC MIXING – SETUP II

In the previous section we saw the downconverting capabilities of the photoswitch and its application in a system. The local oscillator was provided by an optical source and the processed data-stream was an electrical RF signal. In the optical section of a RoF system the optically provided data-stream is converted to the electrical domain with a photoconductor and then is transmitted wirelessly. The optical signal is modulated with the data on a carrier signal at a frequency f_c , thus after detection the electrical signal has the same f_c carrier signal. In the following, we are demonstrating our proposed system for downconverting the optically received data signal for signal processing. The scheme can demodulate the data stream to the baseband or to directly convert the data-stream to a different frequency with the help of an electrical local oscillator. The setup is

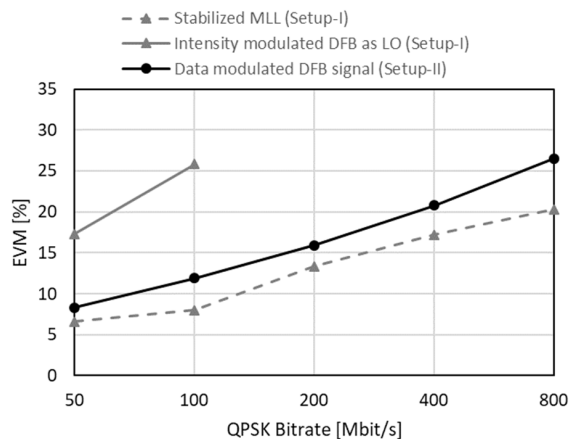

Fig. 8. Setup-II results. Measured Error Vector magnitude values versus the applied bitrate of the data-stream. Setup-II results are compared to Setup-I.

Optoelectronic mixer with photoconductive switch for 1550 nm wavelengths

illustrated on Fig. 7. The same DFB laser as in the previous setup is used here without the EDFA. The generated data-stream is from the AWG and the signal generator is modulating the optical signal through the Mach-Zehnder modulator. Utilizing a MZM we can achieve higher bandwidths compared to directly modulating the DFB laser cavity. The average optical power after the MZM is 3 dBm (2 mW). In the experiment we used the same LO frequency as in the case of Setup-I, but now we have an electrical LO at the input of the photoswitch. This local oscillator generates a sinusoidal signal with 19 dBm power and 24.55 GHz frequency provided by an Agilent signal generator. This LO signal has a superior frequency stability and quality compared to the ones provided by the lasers for Setup-I. The carrier frequency of the data-stream is also the same as in the previous setup at 20 GHz.

These settings resulted again in a downconverted signal at 4.55 GHz at the output of the photoswitch. A low-pass filter was filtering out the feedthrough signals through the photoswitch and prevented the overload of the following low-noise amplifier (38 dB). A DSO was performing the data demodulation after the amplifier. The data-stream in this case was also QPSK modulated with 50-100-200-400-800 Mbit/s data rates. As in the previous setup, we were measuring the demodulated signal's Error Vector Magnitude (EVM) value. The results are shown in Fig. 8 along with the results from the stabilized MLL case and DFB case from Setup-I as an indication. We measured an EVM of 8.3 % for 50 Mbit/s, which increases to 26.5 % for 800 Mbit/s. The results are close to the one obtained with an optical LO from the stabilized MLL.

V. CONCLUSIONS

We demonstrated two optoelectronic mixer schemes utilizing a photoconductive switch. In the first scheme, the local oscillator is an optical signal from an MLL at a frequency of 24.5 GHz, with a reduced linewidth thanks to a stabilizing all-optical feedback loop. The wide bandwidth of the PSW, estimated to be higher than 100 GHz, gives a wide possible frequency range for the system design. The mixing conversion loss is rivaling with the unbiased UTC-PDs and shows good stability over a wide frequency range. In order to investigate the benefit of such an optoelectronic system, as a proof of concept we performed QPSK data demodulation in a RoF data transmission link. The higher performance of the stabilized MLL over the free-running MLL and modulated DFB signal was shown. We measured an EVM of 6.6 % for 50 Mbit/s QPSK modulated signal which increased to 21.6 % with a higher data-rate of 800 Mbit/s.

In the second optoelectronic mixing scheme, the local oscillator signal is electrical. The data-stream is intensity modulating a continuous wave DFB laser. The mixing showed a good performance with 16 % EVM for 200 Mbit/s data rate. A possible application of the photoconductive switch is in an RoF network, where the data-stream modulated optical signal is received then can be directly down or up converted for electrical transmission to a

different carrier frequency depending on the application demands.

The two experiments demonstrate the capability of using either the optical or the electrical signal as local oscillator. The measured EVM values are compatible with wireless communication requirements in case of Forward Error Correction (FEC) coding of the data-stream, where part of the transmitted data is used for error correction. The results can be improved by utilizing higher power lasers and low-noise amplifiers and also by improving the switch structures as in [9] for higher efficiency of the optical detection. These results are showing the flexibility of the photoswitch, operating over a large bandwidth, both in the electrical and optical domain. The schemes are giving a feasible photonic solution for a heterodyne receiver in a RoF wireless link or for the optical link and opens the way to the design of new photonic assisted mmW telecommunication links.

ACKNOWLEDGMENT

The authors would like to thank Cyril Renaud from UCL, London, UK for his valuable help with the MLL feedback, and Chris Graham also from UCL for providing the photoconductive switch samples. We also thank Frédéric van Dijk from III-V Lab, Palaiseau, France for providing the mode-locked laser and Nicolas Corrao from IMEP-LAHC, Grenoble, France for his help with the experimental setups.

REFERENCES

- [1] Nagatsuma, T., Ducourmau, G., & Renaud, C. C. (2016). "Advances in terahertz communications accelerated by photonics," *Nat Photon*, 10(6), 371–379. doi: 10.1038/nphoton.2016.65
- [2] Dietz, B. Globisch, H. Roehle, D. Stanze, T. Göbel, and M. Schell, "Influence and adjustment of carrier lifetimes in InGaAs/InAlAs photoconductive pulsed terahertz detectors: 6 THz bandwidth and 90dB dynamic range," *Opt. Express* 22, 19411-19422 (2014). doi: 10.1364/OE.22.019411
- [3] H.-J. Song, T.-W. Kim, S. J. Jo, C.-H. Lim, K.-H. Oh, S.-G. Ihn, and J.-I. Song, "Microwave Photonic Mixer Utilizing an InGaAs Photoconductor for Radio over Fiber Applications," *IEICE Trans. Electron.*, vol. E90, p. 457, 2007. doi: 10.1093/ietele/se90-c.2.457
- [4] C. Graham, R. Gwilliam, and A. Seeds, "Nitrogen ion implanted InP based photo-switch," *Opt. Express* 20, 26696-26703 (2012). doi: 10.1364/OE.20.026696
- [5] R. Horvath, J. F. Roux, J. L. Coutaz, J. Poëtte, B. Cabon and C. Graham, "Ultrafast InGaAs photoswitch for RF signal processing," 2017 International Conference on Optical Network Design and Modeling (ONDM), Budapest, 2017, pp. 1-5. doi: 10.23919/ONDM.2017.7958541
- [6] K. Grigoras, A. Krotkus, and A. Deringas, "Picosecond lifetime measurement in semiconductor by optoelectronic autocorrelation," *Electronics Letters*, 27, 1024-1025, (1991).
- [7] A. Akrouf, F. van Dijk, G. H. Duan, A. Shen, F. Lelarge and A. Ramdane, "Low phase noise optical oscillator at 30GHz using a quantum dash mode-locked laser associated with an optical self injection loop," 2009 International Topical Meeting on Microwave Photonics, Valencia, 2009, pp. 1-3.
- [8] E. Rouvalis, M. Fice, C. Renaud, and A. Seeds, "Optoelectronic detection of millimetre-wave signals with travelling-wave unitravelling carrier photodiodes," *Opt. Express* vol. 19, 2079-2084, 2011. doi: 10.1364/OE.19.002079
- [9] E. Peytavit, S. Formont, J.-F. Lampin, "GaAs Fabry-Perot cavity photoconductors: switching with picjoule optical pulses," *Electron. Lett.*, 49 (3), pp. 207-208 (2013). doi: 10.1049/el.2012.3993



Róbert Horváth has received B.Sc. and M.Sc. degrees in electrical engineering from Budapest University of Technology and Economics, Budapest, Hungary in 2013 and 2015 respectively. Since October, 2015 he is pursuing his Ph.D. degree at IMEP-LAHC laboratory (Grenoble-INP, CNRS) in Grenoble, France as an Early Stage Researcher in the FiWin5G Marie-Curie ITN project. His interests are in Microwave photonics, photoconductive switches, photonic assisted Analog-to-digital conversion and semiconductor mode-locked laser.



Jean-François Roux Engineer and M. Sc from the University of Strasbourg, France, in 1990, PhD from Institut Polytechnique Grenoble (Grenoble-INP) in 1995 for a thesis in non-linear integrated optics. He joined the Université Savoie Mont-Blanc in 1996 where he is now an associate Professor at IMEP-LAHC Laboratory. His research activities concern the generation, detection and processing of RF to THz signals using ultrafast optoelectronics. He is also involved in THz time domain spectroscopy and generation of THz signals using high power femtosecond laser.



Julien Poëtte Engineer and B.Sc in 2002, PhD in physics in 2005 from RENNES 1 University (France), is associate professor at Grenoble-INP since 2008 (National Polytechnics Institute of Grenoble, France). His research activities concern next generation communication systems involving microwave-photonics techniques, optical noise, and optical solution for carrier generation at millimeter wave frequencies and beyond.



Béatrice Cabon, Ph.D. from the Institut Polytechnique Grenoble (Grenoble-INP), France, in 1986, and professor from 1989. She is Head since 1993 of a research group on microwave-photonics techniques at IMEP-LAHC, Institute for Microelectronics, Electromagnetism and Photonics laboratory, Grenoble France. From 1998 to 2008, she has been also coordinator of the club "optics and microwaves" of the French Optical Society. She also coordinated two European projects Networks of Excellence funded by the European commission,

FP6-IST- 2001-32786 « NEFERTITI » (2002-2005) and FP6-IST-26592 « ISIS » (2006-2009). Her research interests include microwave-photonics, photonic- microwave signal processing, and optical links for high bit rate signals. She has authored or co-authored more than 300 technical publications and is the Editor of five books in these areas.