

Current usage by a DC motor to vary ratio in an electro-mechanical continuously variable transmission

L J Delhaise¹, I I Mazali*², Z H C Daud², M S C Kob² and Z Asus²

¹Institut Supérieur de l'automobile et des Transports, Université de Bourgogne, France

²School of Mechanical Engineering, Universiti Teknologi Malaysia, Johor Bahru, Johor, Malaysia

*Corresponding author E-mail: izhari@mail.fkm.utm.my

Abstract. In a typical continuously variable transmission (CVT) for automotive, engine torque is transmitted from the primary pulley (connected to the vehicle's engine) to the secondary pulley (connected to the wheels) through a metal pushing V-belt. The CVT ratio (r_{CVT}) is defined as the pitch radius of the belt on the secondary pulley divided by the pitch radius on the primary pulley. Conventionally, r_{CVT} is varied using hydraulic pressure generated by an oil pump which is powered by the engine. A continuous hydraulic pressure is required to maintain high clamping force applied on the belt so that sufficient traction between the belt and the pulleys can always be provided. This requirement, unfortunately, causes significant power losses in the CVT and to address this, the idea of electro-mechanical CVT (EM CVT) is proposed. In an EM CVT, r_{CVT} is varied using a power screw mechanism and a DC motor while the desired ratio and the belt's clamping force is maintained using the thread of the power screw mechanism, consequently eliminating the aforementioned issue. This paper describes the process of measuring the current used by a DC motor to vary r_{CVT} in an EM CVT. The results show that the current usage is higher during upshifting from r_{CVT} of 1.95 to 1.43 (about 45 A) as compared to downshifting from 1.43 to 1.95 (about 23 A). This is due to the application of disc springs in the secondary pulley that reduces the required motor torque for downshifting. The results also prove that no current is consumed by the motor during a constant r_{CVT} . In conclusion, the motor's current usage has been successfully measured and the results can be used for a future development of the EM CVT's battery system.

1. Introduction

Powertrain systems for automotive applications can be divided into two categories namely (1) conventional powertrain system and (2) alternative powertrain system. In a conventional powertrain system, an internal combustion engine (ICE) is used to power a vehicle while an alternative powertrain system involves either hybrid or full electric vehicle (EV) technologies. While the alternative powertrain system is fast gaining popularity due to its relatively high efficiency and low emission, its overall operational cost now is still generally more expensive as compared to a conventional powertrain system. Because of this situation, there are still many works recently carried out on the conventional system to further improve its performances particularly in terms of its fuel efficiency. These works cover many areas and one of them is the transmission technologies.

The purpose of a transmission in a powertrain system, among others, is to allow an ICE to operate in its most efficient conditions to suit various driving situations by utilising the transmission's set of



ratios. There are many types of transmission developed to maximised fuel efficiency of the ICE and one of them is continuously variable transmission (CVT). In a CVT, the ratio (r_{CVT}) is defined by the pitch radius of the metal pushing V-belt on the secondary pulley (R_{sec}) divided by the belt's pitch radius on the primary pulley (R_{pri}). The primary pulley is coupled to the vehicle's ICE while the secondary pulley is connected to the wheels. CVT offers continuous r_{CVT} range which contributes in improving the fuel consumption of the ICE. However, the existing CVTs apply oil pump to generate continuous hydraulic pressure for varying r_{CVT} as well as for clamping the metal pushing V-belt. The oil pump is powered by the ICE, hence continuous dissipation of its power is expected during the CVT's operation. According to Naunheimer *et al.* (2011) and Kirchner (2007), an oil pump in a CVT needs to produce up to 70 bar of hydraulic pressure for the belt's clamping force and this causes significant power losses ranging from 100 W to 1 kW. To overcome this issue, some researchers have proposed the idea of electro-mechanical CVT (EM CVT).

In an EM CVT, the application of ICE-powered oil pump is being replaced with an electro-mechanical (EM) actuation system that mainly comprises of a DC motor and a power screw mechanism. Torque from the DC motor is converted into an axial force by the power screw mechanism and the force is then used to adjust the axial position of the primary and the secondary pulleys so that r_{CVT} can be varied accordingly. Next, the belt's clamping force is maintained through a self-lock mechanism of the power screw's thread. As such, the dissipation of ICE power can be avoided. However, the operation of EM actuation system needs a comprehensive battery system together with its charging solution. This paper describes the process to experimentally measure the current usage by a DC motor to vary r_{CVT} in an EM CVT. The current usage profile obtained from this process is very crucial for the future development of the EM CVT's battery system.

2. Experimental Test Rig for the Electro-Mechanical CVT

Since early 2000s, researchers in Universiti Teknologi Malaysia (EM CVT) have introduced numerous designs of EM CVT and some of the designs have reached the level of laboratory-scaled prototype (Supriyo *et al.*, 2013 and Tawi *et al.*, 2015). The latest version of UTM's EM CVT is described in Mazali *et al.* (2017) with its layout shown in Figure 1. It uses one DC motor (ratio motor) to vary r_{CVT} while another DC motor (clamping motor) is used to change the clamping force applied on the metal pushing V-belt. Both of these motors are 24 V brushless type with a rated torque of 1.2 Nm at 3000 RPM.

In this paper, the prototype of the same EM CVT's version as in Mazali *et al.* (2017) is used. To vary r_{CVT} , the ratio motor is manually controlled so that its torque can be transferred to rotate the primary and the secondary ratio gears. These gears are meshed with their respective power screws and the rotation of the gears causes an axial movement of the screws to vary r_{CVT} . The value of r_{CVT} is defined as the rotational speed of the primary pulley divided by the rotational speed of the secondary pulley and these speeds are measured by two speed sensors (rotary encoders OMRON E6-C3 CWZ 3EH) each coupled to the primary pulley and the secondary pulley, respectively. An AC motor is used to act as an engine that gives an input torque to the CVT's primary pulley with a constant speed of about 57 RPM.

To measure the current usage of the ratio motor, a current sensor (LEM LA 55-P) is used in the electrical connection between the ratio motor and 24 V batteries set. The sensor is powered by a 12 V DC power supply and its wiring diagram is shown in Figure 2. I_P is the measured current from the ratio motor, I_S is the secondary current flow converted based on I_P and R_M is the measuring resistance. The output of the sensor is connected to Arduino Uno's analog pin and the sensor is capable of measuring a current from 0 A to 50 A. The Arduino board is connected to Matlab/Simulink with its block diagram illustrated in Figure 3. The objective of the block diagram is to convert the analog signal from the Arduino board into current in the unit of A. The value of analog signal is from 0 to 1023 representing 0 V to 5 V detected by the sensor. Once the analog signal is converted into a voltage signal, a gain block of $1/R_M$ is used to convert the voltage into I_S with 100 Ohms as the value of R_M . Next, based on the sensor's conversion ratio of 1:1000 in

accordance to its specifications, another gain block of 1000 is used so that I_s can be converted into I_p . The readings for I_p given by the sensor are validated using a portable ammeter. The process of measuring the ratio motor's current usage is carried out between r_{CVT} of 1.95 and 1.43 with no braking torque applied on the secondary pulley.

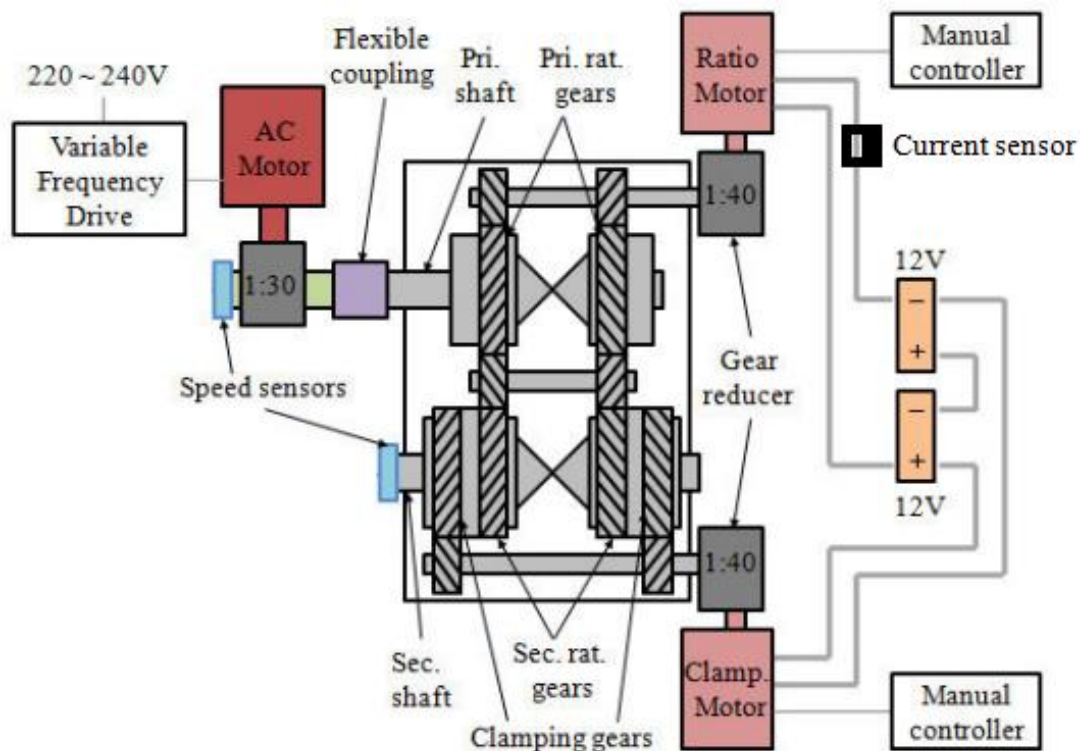

Figure 1. The simplified layout of EM CVT used in this experiment.

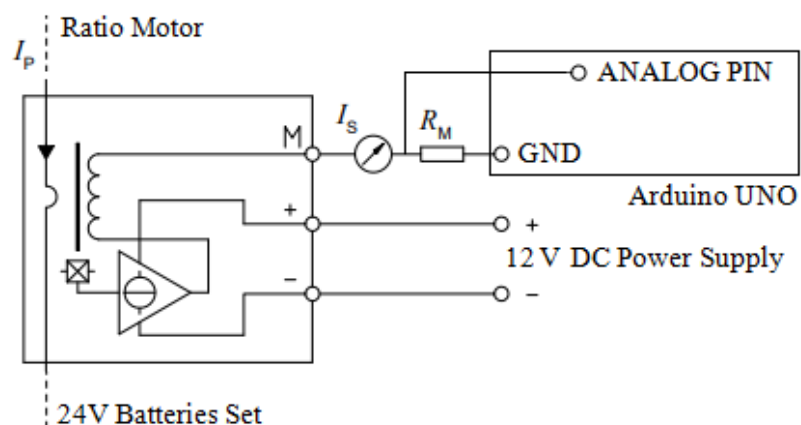

Figure 2. The wiring diagram of the current sensor LEM LA 55-P (LEM, 2018).

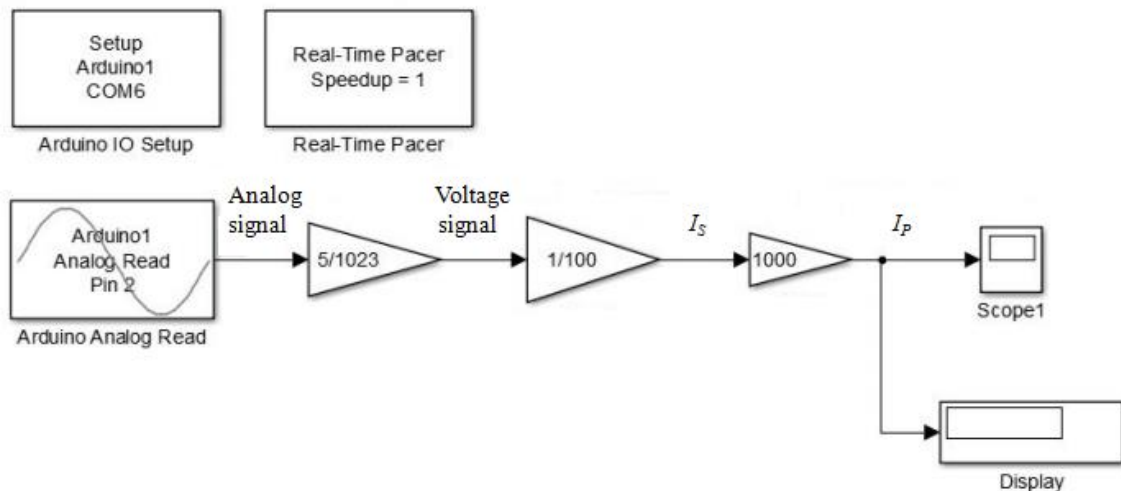

Figure 3. Block diagram to read the current sensor in Matlab/Simulink.

3. Results and Discussions

The actual experimental test rig is shown in Figure 4 and Figure 5 provides the graphs of the pulleys' speed and r_{CVT} . Based on the graphs, the process of upshifting (changing of r_{CVT} from 1.95 to 1.43) starts at about 3.8 s and ends at 8.8 s. Then, r_{CVT} is maintained at around 1.43 until 14.2 s where the downshifting is performed to reach r_{CVT} of about 1.95. The downshifting time ends at 16.4 s and consequently r_{CVT} remains constant at 1.95. During the upshifting and downshifting, the speed of the primary pulley stays at circa 57 RPM while the secondary pulley's speed is changed from about 29 RPM (r_{CVT} of 1.95) to about 40 RPM (r_{CVT} of 1.43).

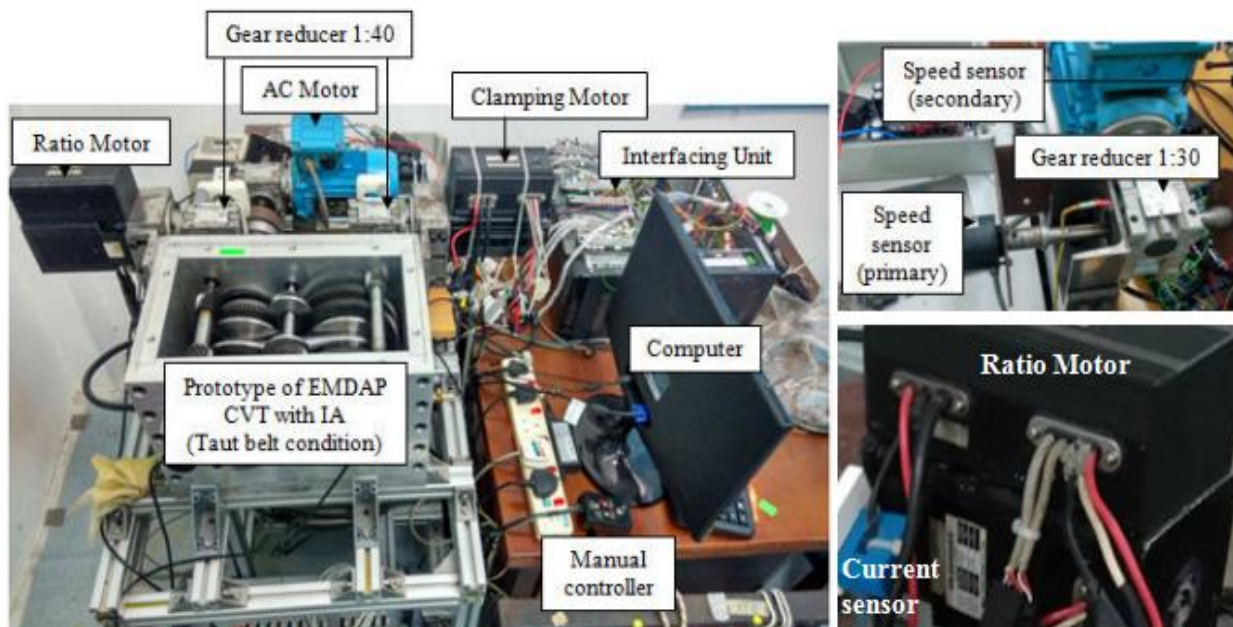

Figure 4. The prototype of EM CVT and its experimental test rig.

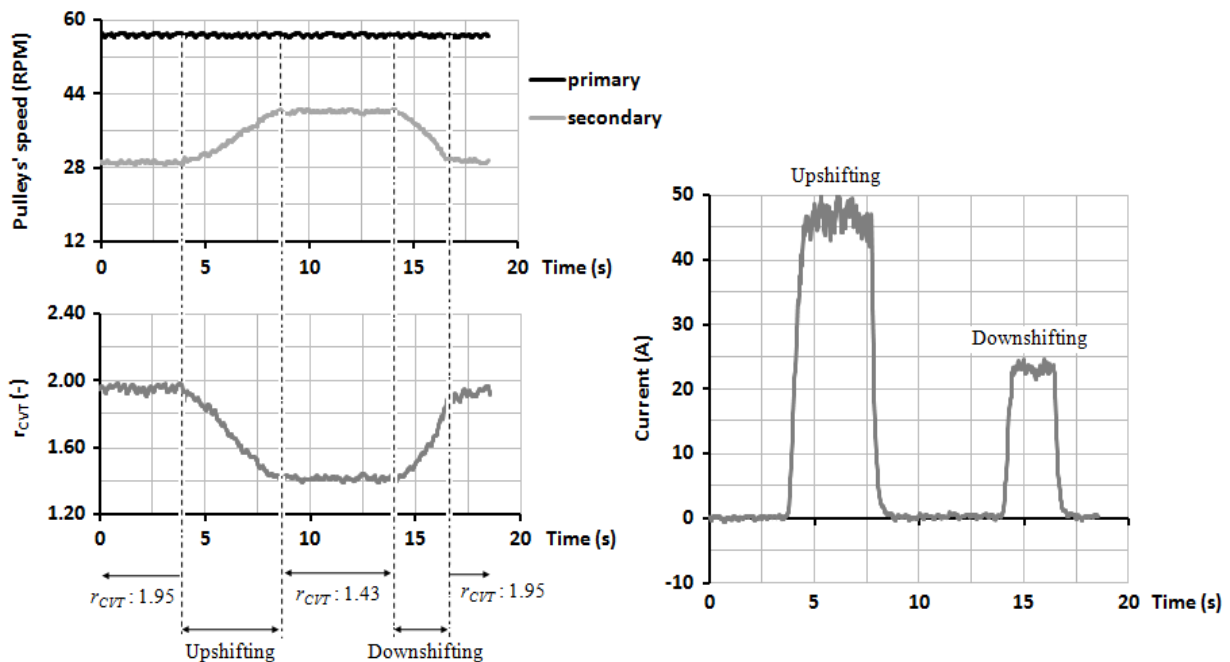

Figure 5. Rotational speeds of the primary and the secondary pulleys, r_{CVT} and current usage.

Also shown in Figure 5 is the current usage of the ratio motor during upshifting and downshifting. For the upshifting, the current used by the ratio motor averaging at about 45 A while for the downshifting, the current used is significantly lower at the average about 23 A. The difference is caused by the application of two-disc springs in the EM CVT's secondary pulley assembly. During the upshifting, the secondary pulley's sheaves are forced to move axially outwards by the metal pushing V-belt. Thus, the direction of the axial movement goes against the force provided by the disc springs, resulting in the increase of the required ratio motor's torque. On the contrary, in downshifting, the axial movement of the secondary pulley's sheaves is supported by the springs' force, hence reducing the required ratio motor's torque. Because of these situations, the current usage during downshifting is significantly lower as opposed to the upshifting.

The results in Figure 5 also prove that no current is used by the motor during constant r_{CVT} . This is possible because of the thread in the power screw mechanism that provides a self-lock capability to the pulleys. With this capability, the clamping force exerted on the metal pushing V-belt can be maintained without giving continuous ratio motor's torque. This condition can significantly improve the efficiency of the CVT.

4. Conclusions

As a conclusion, the current used by the ratio motor in the prototype of EM CVT vary r_{CVT} between 1.95 and 1.43 has been successfully measured. The results show that the current consumed by the ratio motor is significantly higher during upshifting as compared to downshifting. This is caused by the application of disc springs in the secondary pulley assembly of the prototype. For the future work, the EM CVT, together with its current measuring system described in this paper, needs to be tested on a dynamometer under a specific driving cycle conditions, so that realistic data of current consumption can be obtained. Then, the process to develop a comprehensive battery system for EM CVT can be initiated.

In addition, the prototype can also be tested for applications in alternative powertrain systems. Recent works by Hoffman and Janssen (2017) and Kim *et al.* (2018) indicate that the increment of number of ratios also contribute in making hybrids and EVs more efficient. Therefore, with a

comprehensive battery system, the suitability and practicality of applying the EM CVT from this paper for hybrids and EVs can be validated in the future.

Acknowledgment

Authors would like to acknowledge Universiti Teknologi Malaysia for funding this project under Research University Grant (Q.J130000.2651.16J75).

References

- [1] Nauheimer, H., Bertsche, B., Ryborz, J. and Novak, W. 2011. *Automotive Transmission; Fundamentals, Selection, Design and Application, Second Edition*. (Heidelberg: Springer).
- [2] Kirchner, E. 2007. *Leistungsübertragung in Fahrzeuggetrieben; Grundlagen der Auslegung, Entwicklung und Validierung von Fahrzeuggetrieben und deren Komponente*. (Heidelberg: Springer).
- [3] Supriyo, B., Tawi, K. B. and H. Jamaluddin. 2012. Experimental study of an electro-mechanical CVT ratio controller. *I. J. of Auto. Tech.* **14**, 2, 313-323.
- [4] Tawi, K. B., Supriyo, B., Ariyono, S., Husain, N. A., Hamid, A. R. A., Azlan, M. A., Mazali, I. I. and Kob, M. S. C. 2015. Design of electro-mechanical dualacting pulley continuously variable transmission. *J. of Mech. Eng. and Sci.* **8**, 1332-1342.
- [5] Mazali, I. I., Tawi, K. B., Supriyo, B., Husain, N. A., Kob, M. S. C. and Kob, M. S. C. 2017. Transmission ratio calibration for electro-mechanically actuated continuously variable transmission. *I. J. of Adv. Mech. Sys.* **7**, 3, 127-133.
- [6] LEM. *Product Datasheet, Current Transducer LA 55-P*. LEM International SA, Plan les Ouates, SWITZERLAND, 2018.
- [7] Hofman, T. and Janssen, N. 2017. Integrated design optimization of the transmission system and vehicle control for electric vehicles. *20th IFAC World Congress*, **50**, 1, 10072-10077.
- [8] Kim, H., Wi, J., Yoo, J., Son, H., Kim, H. and Park, C. 2018. Influence of Number of Gear Step on Engine and Motor Operation Characteristics for Parallel HEV. *Int. Conf. on Eco. Veh. and Renew. Ener. (EVER)*.